



Designation: F 2118 – 01a³

Standard Test Method for Constant Amplitude of Force Controlled Fatigue Testing of Acrylic Bone Cement Materials¹

This standard is issued under the fixed designation F 2118; the number immediately following the designation indicates the year of original adoption or, in the case of revision, the year of last revision. A number in parentheses indicates the year of last reapproval. A superscript epsilon (ϵ) indicates an editorial change since the last revision or reapproval.

1. Scope

1.1 This ~~standard test method~~ describes test procedures for evaluating the constant amplitude, uniaxial, tension-compression uniform fatigue performance of acrylic bone cement materials.

1.2 This ~~standard test method~~ is relevant to orthopaedic bone cements based on acrylic resins, as specified in Specification F 451. The procedures in this ~~guide test method~~ may or may not apply to other surgical cement materials.

1.3 It is not the intention of this ~~standard test method~~ to define levels of performance of these materials. Furthermore, it is not the intention of this ~~standard test method~~ to directly simulate the clinical use of these materials.

1.4 A rationale is given in Appendix X1.

1.5 The values stated in SI units are to be regarded as the standard.

1.6 *This standard does not purport to address all of the safety concerns associated with its use. It is the responsibility of the user of this standard to consult and establish appropriate safety and health practices and determine the applicability of regulatory limitations prior to use.*

2. Referenced Documents

2.1 *ASTM Standards:*

¹ This test method is under the jurisdiction of ASTM Committee F04 on Medical and Surgical Materials and Devices and is the direct responsibility of Subcommittee F04.15 on Material Test Methods.

Current edition approved ~~October~~ Sept. 10, 2004³. Published ~~November 2001~~. October 2003. Originally published as ~~F2118 – 01~~. approved in 2001. Last previous edition approved in 2001 as F2118 - 01a.

E 466 Practice for Conducting Force Controlled Constant Amplitude Axial Fatigue Tests of Metallic Materials²

E 467 Practice for Verification of Constant Amplitude Dynamic Forces in an Axial Fatigue Testing System²

E 1823 Terminology Relating to Fatigue and Fracture Testing²

F 451 Standard Specification for Acrylic Bone Cement³

2.2 *ISO Standard:*

ISO 7206-8 Implants for Surgery, Partial and Total Hip Joint Prostheses, Part 8—Endurance Performance of Stemmed Femoral Components with Application of Torsion⁴

3. Terminology

3.1 Unless otherwise given, the definitions for fatigue terminology given in Terminology E 1823 will be used.

3.1.2 *Median-F fatigue-S strength at N-C cycles*—The maximum stress at which 50 % of the specimens of a given sample would be expected to survive *N* loading cycles. For the purposes of this test method, the fatigue strength will be determined at 5 million load cycles. A rationale for this is provided in the Appendix X1.4.

3.2 *Runout*—A predetermined number of cycles at which the testing on a particular specimen will be stopped, and no further testing on that specimen will be performed. For the purposes of this test method, the runout will be 5 million load cycles.

3.3 *Stress Level runout*—The value—A predetermined number of stress cycles at which the testing on a series of duplicate tests are particular specimen will be stopped, and no further testing on that specimen will be performed. For the purposes of this test method, the stress level is reported as the maximum stress applied to the specimen. runout will be 5 million load cycles.

3.4 *Stress level*—The value of stress at which a series of duplicate tests are performed. For the purposes of this test method, the stress level is reported as the maximum stress applied to the specimen-F.

3.5 *specimen failure*—The condition at which the specimen completely breaks or is damaged to such an extent that the load frame is no longer able to apply the intended stress within the required limits.

4. Summary of Test Method

4.1 Uniform cylindrical reduced gage section test specimens are manufactured from acrylic bone cement and mounted in a uniaxial fatigue frame. The specimen is subjected to fully reversed tensile and compressive loading in a sinusoidal cyclic manner at a specified frequency in phosphate buffered saline (PBS). The fatigue loading is continued until the specimen fails or a predetermined number of cycles (runout limit) is reached.

5. Significance and Use

5.1 This test method describes a uniaxial, constant amplitude, fully reversed fatigue test to characterize the fatigue performance of a uniform cylindrical waisted specimen manufactured from acrylic bone cement.

5.2 This test method considers two approaches to evaluating the fatigue performance of bone cement:

5.2.1 Testing is conducted at three stress levels to characterize the general fatigue behavior of a cement over a range of stresses. The stress level and resultant cycles to failure of the specimens are plotted on an *S-N* diagram.

5.2.2 Another approach is to determine the fatigue strength of a particular cement. The fatigue strength for orthopaedic bone cement is to be determined at 5 million (5×10^6) cycles. The “two-point method” is the specified procedure for conducting fatigue testing to determine fatigue strength [1].

5.3 This standard test method does not define or suggest required levels of performance of bone cement. This fatigue test method is not intended to represent the clinical use of orthopaedic bone cement, but rather to characterize the material using standard and well-established methods. The user is cautioned to consider the appropriateness of this test method in view of the material being tested and its potential application.

5.4 It is widely reported that multiple clinical factors affect the fatigue performance of orthopaedic bone cement; however, the actual mechanisms involved are not well understood. Clinical factors which may affect the performance of bone cement include: temperature and humidity, mixing method, time of application, surgical technique, bone preparation, implant design, and patient factors, among others. This test method does not specifically address these clinical factors. The test method can be used to compare different acrylic bone cement formulations and products and different mixing methods and environments (that is, mixing temperature, vacuum, centrifugation, and so forth).

6. Apparatus

6.1 *Uniaxial Load Frame*—A testing machine capable of applying cyclic sinusoidal tensile and compressive loads.

6.1.1 The crossheads of the load frame shall be aligned such that the alignment meets the requirements of 8.2 of Practice E 466. The alignment should be checked at both the maximum tensile and minimum compressive load to be applied during the course of a test program.

² Annual Book of ASTM Standards, Vol 03.01.

³ Annual Book of ASTM Standards, Vol 13.01.

⁴ Available from American National Standards Institute, 25 W. 43rd St, 4th Floor, New York, NY 10036.

6.2 *Cycle Counter*— A device capable of counting the number of loading cycles applied to a specimen during the course of a fatigue test.

6.3 *Load Cell*—A load cell capable of measuring dynamic tensile and compressive loads in accordance with Practice E 467.

6.4 *Limit*—A device capable of detecting when a test parameter (for example, load magnitude, actuator displacement, DC error, and so forth) reaches a limiting value, at which time the test is stopped and the current cycle count recorded.

6.5 *Environmental Chamber*—A chamber designed to immerse the fatigue specimen completely in a solution. The chamber should have provisions for maintaining a constant temperature to an accuracy of $\pm 2^{\circ}\text{C}$.

7. Test Specimen

7.1 Test specimens shall be fabricated from cement that is representative of the final product with regard to materials, manufacturing processes, sterilization, and packaging. Sterilization methods have been shown to have an effect on fatigue performance. Any deviations of the test cement from the clinically used product must be reported.

7.2 Cylindrical reduced gage section test specimens with a straight 5-mm diameter by 10-mm-long gage section shall be used. The diameter of the specimen ends shall be substantially greater than the gage diameter to ensure that fracture occurs in the gage section. A smooth radius or taper between the specimen ends and gage section is suggested to ensure the gage section is subjected to a uniform stress field. Suggested specimen dimensions are provided in Fig. 1.

8. Specimen Preparation

8.1 Cement Mixing

8.1.1 Store the liquid and powder portions of the cement according to the manufacturer's instructions before mixing.

8.1.2 Allow the mixing equipment to equilibrate to room temperature before mixing. Record the room temperature at the onset of mixing.

8.1.3 Mix the powder and liquid components according to the manufacturer's instructions and begin recording the time from this point using a stopwatch. Report any deviations from the manufacturer's storage and mixing recommendations.

8.1.4 Report the mixing method and any equipment used. The method used for mixing the cement may affect its fatigue behavior. See X1.13 for further information.

8.2 *Specimen Fabrication*—The cylindrical reduced gage section test specimens are fabricated using one of two methods:

8.2.1 Direct Molding:

8.2.1.1 Insert the mixed cement into a specimen mold (manufactured from silicone, aluminum, TeFE-fluorocarbon, or other suitable material) with an internal cavity which has the same dimensions as the final cement test specimen. Close the mold. Record the method of cement insertion into the mold (that is, pour or inject) and method used to close the mold.

8.2.1.2 Place the mold in a container of phosphate buffered saline (PBS). The PBS solution should be maintained at $37 \pm 2^{\circ}\text{C}$. After the specimens have polymerized for at least 1 h, the specimens may be removed from the mold. Appendix X2 describes a suggested procedure for molding cement specimens.

8.2.2 Machining:

8.2.2.1 Insert the mixed cement into cylindrical mold (manufactured from aluminum, glass, or TeFE-fluorocarbon tube). The inside diameter of the molding tube should be a few millimetres greater than the final specimen grip diameter.

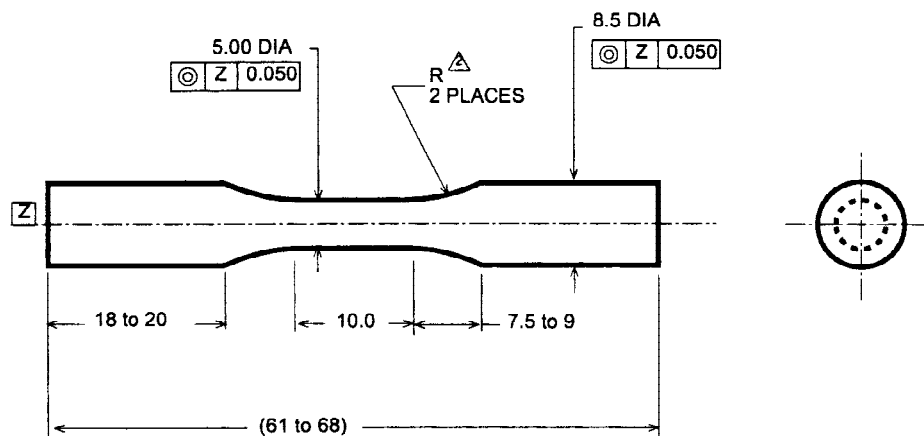

1. All dimensions in mm

Δ Radius to blend smoothly with gage section

3. Tolerances: X. = ± 1.0
 X.X = ± 0.5
 X.XX = ± 0.1

FIG. 1 Specimen Dimensions

8.2.2.2 Maintain the temperature of the mold at $37 \pm 2^\circ\text{C}$. After the specimens have polymerized for at least 1 h, the specimens may be removed from the mold.

8.2.2.3 Machining should not be performed until at least 24 h after initial mixing to ensure that the cement is completely polymerized.

8.3 Specimen Examination:

8.3.1 Radiographically examine the fabricated specimens for internal defects. Visually examine specimens for surface defects. Defects in the gage or transition sections (radii) shall be rejected from testing and discarded. A surface defect is defined as a surface discontinuity greater than $250\ \mu\text{m}$ in major diameter. In addition, the specimens shall be examined radiographically in two orthogonal planes. Specimens with internal defects greater than 1 mm in major diameter in the gage section shall be rejected from testing and discarded. The total number of specimens rejected divided by the total number of specimens manufactured (rejection rate) shall be reported. A rationale for these rejection criteria is provided in X1.11.

NOTE 1—The development of fabrication defects may be related to the tendency of a material to develop porosity during polymerization. The amount of porosity or fabrication defects in the test specimens may be a characteristic of the cement being evaluated. The rejection rate may give a general indication of a material's tendency toward porosity formation.

8.4 *Specimen Finishing*—If necessary, lightly polish the gage length of the specimens with 600-grit abrasive paper in the longitudinal direction until the surface is free of machining and/or mold marks.

8.5 *Specimen Measurement*—Measure the diameter of the specimens at a minimum of three places along the gage length of each specimen. The average of these measurements shall be used as the specimen's gage diameter for calculation of the required load.

8.6 Specimen Conditioning:

8.6.1 Place the test specimens in PBS which is maintained at a temperature of $37 \pm 2^\circ\text{C}$.

8.6.2 Maintain the specimens in the PBS solution for a minimum of 7 days. The cement specimens shall be maintained in the PBS solution for 7 to 60 days. The specimens shall be continually immersed in the test solution so that they do not dry out. Distilled water shall be added to the soaking chamber during the soaking period to make up for evaporation loss. Each specimen should be soaked up to the time immediately before its being mounted on the load frame. See X1.5 for further information.

9. Fatigue Test Procedures

9.1 Mount the specimens in a test frame test such that a uniaxial load is applied. Collets, Jacob's chucks, or pressurized grips should be used to firmly grip the specimen at each end. Ensure the longitudinal centerline of the test specimens are aligned with test machine loading axis such that no bending moment may be applied to the specimens.

9.2 Mount an environmental chamber on the load frame and fill with fresh test solution immediately after the specimen is mounted to keep the specimen from drying out. The chamber should be filled to a level such that the entire specimen is immersed. Distilled water shall be added to the test chamber during the course of a test to make up for evaporation loss. The temperature controller should be programmed and activated to heat the test solution to 37°C , and then maintain that temperature within $\pm 2^\circ\text{C}$. Fatigue testing should not begin until at least $\frac{1}{2}$ h after the solution temperature has reached 37°C to ensure equilibration.

9.3 Program the test frame controller to apply a fully reversed sinusoidal cyclic waveform at a constant frequency. When testing at frequencies above 2 Hz, the user should verify that, for the formulation being tested, the chosen frequency has a negligible effect on the test results. See X1.6 for further information.

9.4 Program the test frame controller to apply the desired maximum stress level and a stress ratio of $R = -1$, indicating fully reversed loading. A rationale for using fully reversed loading is provided in Appendix X1.10. The load shall be calculated by multiplying the desired stress by the specimen's cross-section area, based on each specimen's gage diameter determined in 8.5.

9.4.1 Report the stress level to the nearest 0.5 MPa.

9.4.2 When developing an $S-N$ curve, it is recommended that testing be conducted at the following maximum stress levels: 15, 12.5, and 10 MPa. Other stress levels may also be appropriate. See X1.7 for a rationale regarding the selection of the recommended stress levels.

9.4.3 When determining a fatigue strength, the stress levels shall be chosen in accordance with the "two-point method" [1].

9.5 *Number of Specimens*—When developing an $S-N$ curve, a minimum of ~~eight~~ fifteen specimens shall be tested at each stress level. The desired statistical power of the comparison and the variability to be expected from the cement formulation(s) being investigated should be considered when determining the appropriate sample size. See X1.12 for further information.

9.5.1 When determining a fatigue strength, the number of specimens shall be chosen in accordance with the "two-point method" [1].

9.6 After the solution has reached the temperature requirements in 9.2, activate the test frame controller to begin the test.

9.7 Set the cycle counter and limit settings of the test frame controller to record the cumulative number of cycles applied to the test specimen and the appropriate test limits values to indicate specimen failure or deviations from the intended load system performance.

9.8 Testing shall continue until specimen failure or the runout limit is reached.

10. Calculation and Interpretation of Results

10.1 The maximum stress and the cycles to failure for each specimen should be recorded and plotted on an $S-N$ diagram [2]. The techniques used to estimate mean fatigue lives, determine probability of survival curves, compare statistical differences

between sample groups, and calculate fatigue strength are described in 10.2-10.7.

10.2 *Mean Fatigue Life*—For each stress level, the mean fatigue life and standard deviation about the mean shall be determined assuming a log-normal distribution [3]. The mean log fatigue life is first determined according to the following equation:

$$X_{\log} = \frac{[\sum \log_{10} (N_i)]}{n} \quad (1)$$

where:

X_{\log} = mean log fatigue life,
 N_i = number of cycles to failure of i^{th} specimen, and
 n = total number of specimens in the sample group.

Using a similar approach, the standard deviation of the mean log fatigue life (S_{\log}) is determined.

These are expressed in more familiar terms, as cycles to failure, by calculating the following:

$$\text{mean fatigue life} = 10^{X_{\log}} \quad (2)$$

$$\text{mean} + 1 \text{ standard deviation} = 10^{(X_{\log} + S_{\log})} \quad (3)$$

$$\text{mean} - 1 \text{ standard deviation} = 10^{(X_{\log} - S_{\log})} \quad (4)$$

10.3 *Probability of Survival Curves* —For each stress level, a probability of survival curve, assuming a logarithmic failure distribution, may be generated using established methods [4]. The probability of survival for each specimen is determined using the following equation:

$$P(y) = 1 - [y - 0.3]/[n + 0.4] \quad (5)$$

where:

$P(y)$ = probability of survival for specimen y ,
 y = failure order number (after ranking the specimens' fatigue lives in ascending order), and
 n = total number of specimens in the sample group

The probability of survival for each specimen tested is then plotted versus the log (cycles to failure) to develop the probability of survival curve for each stress level. From this, the median fatigue life may be determined from the point on the curve corresponding to $P = 0.5$, and probability of survival curves may be generated.

10.4 *Weibull Survival Curves*—For each stress level, a Weibull survival curve shall be generated using established methods [5]. The generalized three-parameter Weibull survival probability is described by the following equation:

$$p(x) = \exp \{ - [(Nx - No)/(Na - No)]^b \} \quad (6)$$

and the linearized form of this equation is

$$b [\ln (Nx - No)] - b [\ln (Na - No)] = \ln \{ \ln [1/P(x)] \} \quad (7)$$

where:

$p(x)$ = Weibull probability of survival for specimen x ,
 $P(x)$ = probability of survival for specimen x (from 10.3),
 Nx = cycles to failure for specimen x ,
 No = minimum life parameter (see following),
 Na = Weibull characteristic fatigue life (36.8 % specimens survive), and
 b = Weibull shape factor (Weibull slope).

and No is determined from the asymptote of the plot of

$$\ln \{ \ln [1/P(x)] \} \text{ versus } \ln (Nx) \quad (8)$$

The slope of the best-fit straight line to the graph of the linearized Weibull survival probability versus the $\ln (Nx - No)$ provides the shape factor b . The characteristic Weibull fatigue life is then determined from substitution back into the linearized equation.

10.5 *Parametric Statistical Comparisons* —Statistical differences between specimen groups may be determined by commonly used methods such as student's t -test or analysis of variance (ANOVA). This comparison is performed at each stress level using published methods [6] which are available through many commercial statistical software packages. It is recommended that the analysis be performed using the log-normal distribution, that is, the log cycles to failure shown in 10.2, as this is a typical procedure used for analyzing fatigue data. Whatever distribution is assumed, an appropriate goodness-of-fit test to determine the suitability of the distribution should be performed. Appropriate tests for determining normality include the Lilliefors test and the Shapiro-Wilk test [7].

10.6 *Nonparametric Statistical Comparisons* —In situations in which the parametric statistical tests are not appropriate, nonparametric statistical methods are suggested for use in determining statistical differences between sample groups. The Mann-Whitney U test is recommended for comparing two sample groups, and the Kruskal-Wallis test is recommended for comparing three or more sample groups. This comparison is performed at each stress level using published methods [6] which are

available through many commercial statistical software packages.

10.7 *Fatigue Strength at 5 Million Cycles*—This is determined using the procedure described for the “two-point method” [1]

10.8 A brief description of the fracture characteristics; results of posttest photography or scanning electron microscopy or both; identification of fatigue mechanism; and the relative degree of transgranular and intergranular cracking would be highly beneficial. In addition, all failed specimens will be examined visually for pores and failure occurring outside the gage area.

11. Report

The test report shall include the following:

11.1 Manufacturer and brand of bone cement.

11.2 Product catalog number, lot number, and expiration date. If the cement is not in its final packing, then the manufacturing date should be provided.

11.3 Composition of bone cement polymer powder and liquid.

11.4 Deviations from clinically used product (if applicable).

11.5 Description of cement storage and mixing method (for example, storage temperature, room temperature, atmosphere, duration, and so forth) and any deviations from the manufacturer’s recommendations.

11.5.1 If vacuum mixing is used, the information and parameters described in 8.1.3 shall be reported.

11.6 Description of specimen fabrication method.

11.7 Description of specimen examination procedures, rejection rate, rejection criteria and rationale for the rejection criteria.

11.8 Duration of preconditioning, provided either for each specimen, or expressed as an average and range of duration.

11.9 Cyclic frequency.

11.10 A summary of the maximum cyclic stress and cycles to failure for each specimen tested.

11.11 A summary for each sample group describing at each stress level the following parameters:

11.11.1 Mean fatigue life ± 1 standard deviation,

11.11.2 Weibull characteristic fatigue life, Weibull slope, and Weibull survival curves.

11.12 A description of the failure mode and failure location for each specimen that failed. Scanning electron microscopy (SEM) is suggested to identify the failure mode.

11.13 If appropriate, an estimate for the fatigue strength should be reported. A description of the analytical or statistical techniques used for determining the fatigue strength should be included.

11.14 Any deviations from the specified test method.

12. Precision and Bias

12.1 Data establishing the precision and accuracy to be expected from this test method have not yet been obtained.

13. Keywords

13.1 acrylic bone cement; fatigue; fatigue strength

APPENDIXES

(Nonmandatory Information)

X1. RATIONALE

X1.1 This test method is intended to provide the user with standard and well-established procedures for evaluating the fatigue properties of bone cement materials. Specimen parameters, test procedures, data analysis techniques, and reporting requirements are provided.

X1.2 The test method does not specify the mixing conditions to use for the preparation of the test specimens. Considerable research is currently being performed on bone cement and the committee did not want to unnecessarily limit the conditions or parameters that are being investigated by excluding them from the standard.

X1.3 It is important to realize that this test method is intended to characterize the bone cement material—not the bone cement which is used *in vivo*. Some consideration has been given to the parameters which the cement encounters during *in vivo* use (37°C temperature and PBS solution); however, it is not practical to try and completely simulate the clinical use of bone cement. The results obtained from this test method characterize the bone cement material for a specified set of conditions, but they may not necessarily reflect the cement’s clinical performance.

X1.4 The orthopaedic literature generally reports that joint replacement patients may be expected to take 2 million to 3 million steps per year (1 million to 1.5 million gait cycles). Therefore bone cement, when used for securing artificial hip and knee joints,

is exposed to millions of loading cycles during its use. It is appropriate to expect that the fatigue testing of bone cement would likewise subject the test specimens to millions of cycles. However, it should be kept in mind that the fatigue testing cycles described herein may not be directly correlated with the duration of clinical implantation because of the limitations described in X1.3. The committee has chosen a runout limit of 5 million load cycles to provide a reasonable representation of the high cycle fatigue loading to which bone cement is exposed while also addressing the economic and practical considerations of testing at realistic load rates (see X1.6) in a reasonable period of time. Further, the 5 million runout limit is consistent with international requirements for fatigue testing of hip prostheses (ISO 7206-8).

X1.5 It is recognized that the total time for which the specimens are presoaked may have an important effect on their fatigue performance since fluid uptake and polymer degradation are functions of time. Most articles in the literature have reported presoaking cement specimens for a minimum of 7 days. This test method provides a maximum presoaking time of 60 days to reasonably minimize the effect of different presoaking times on the results. It has been shown that most formulations of acrylic cement will experience a weight gain of 2.0 to 2.5 % during an extended soak period of 100 days [8]. It is recommended that the user identify a uniform presoak time that brings the specimens to a weight-gain plateau at which they are gaining less than 0.2 % of their weight per week. As reasonably possible, all of the test specimens should have the same soaking time before testing.

X1.6 Because acrylic bone cement is a viscoelastic material, its cyclic stress-strain behavior is rate dependent. Therefore, cyclic frequencies similar to that expected in clinical use are most appropriate. It has been shown in tension-tension tests that an elevation in the testing frequency tends to increase the fatigue life of bone cement [9]. The user is cautioned to verify from the literature or from new tests that for the formulation being tested the use of any elevated cycling has a negligible effect on the results.

X1.7 When establishing an $S-N$ curve, it is important that the specimens are subjected to stress levels which the cement would likely experience *in vivo*. For normal joint loading, the nominal tensile stress levels in the cement mantle surrounding a stable hip stem are reported to be between 3 and 11 MPa [10-12]. The specified maximum stress levels are chosen to provide sufficient finite life fatigue data to develop an $S-N$ curve, while providing some data in the range of expected *in vivo* stresses.

X1.8 Differences in specimen fabrication method (for example, molded or machined, mold materials, machining parameters, and so forth) may lead to different test results for the same cement, tested under identical conditions. The scientific literature does not provide a clear indication as to the preferred method of specimen fabrication. For the current time, the standard provides a recommended procedure, while allowing alternative methods, provided they are fully described. The user is cautioned against comparing different sets of data generated using this even though the same procedures are used for specimen preparation because of variability in specimen preparation from one investigator to another. Whenever possible, investigator(s) should plan to test their own concurrent controls for comparisons and not rely on previously published values.

X1.9 Fatigue of the cement mantle has been implicated as one of the mechanisms leading to orthopaedic prosthesis loosening and eventual arthroplasty failure [5]. Fractographic analysis of cement explanted from failed prostheses demonstrate characteristics consistent with PMMA fatigue crack initiation and propagation to failure [13]. The polymer chemistry, molecular weight, radiopacifier, voids, mixing method, and sterilization method have all been presented by various authors as influencing the fatigue properties of bone cement. The test method described herein provides a means for evaluating the effect of these various parameters in a controlled manner.

X1.10 The cement mantle surrounding hip and knee implants is subjected to complex tensile and compressive stresses. Generally, fatigue cracks will only initiate and extend under localized tensile stresses. Fully reversed loading has been selected for this test method for two reasons: (1) for a given maximum stress, fully reversed loading provides the most conservative estimate of fatigue performance, and (2) the vast majority of the bone cement fatigue data in the U.S. literature uses fully reversed loading.

X1.11 The rejection criteria are used to eliminate specimens from testing that do not represent consistent samples of the bone cement material. The two different rejection criteria (for surface and internal defects) are a result of two primary considerations. First, surface defects are more likely to serve as stress initiators and to be a result of scratches/damage caused by mold damage, specimen handling, poor machining practice, and so forth. Therefore, specimens with these types of defects (even if small) should be excluded because they don't represent a uniform material specimen. Similar exclusions are used with metallic specimens. Secondly, using standard X-ray film, it is difficult to identify accurately and measure internal porosity. For this reason, it is unreasonable to specify a tighter restriction than the 1-mm diameter for internal pores.

X1.12 ~~The orthopaedic literature typically reports testing five sample size minimum of fifteen was felt by the task group to ten specimens at each stress level when generating be an appropriate balance of (1) the requirement for having sufficient data to allow statistical comparisons and generation of the $S-N$ curve for acrylic bone cement. The sample size minimum of eight was felt by the task group to be an appropriate balance of (1) the requirement for having sufficient data to allow statistical comparisons and generation of the $S-N$ curve with (2) the resources required to perform high-cycle fatigue testing. The user is encouraged to calculate the power of the test comparisons, using well-published methods [6], for the particular cement formulation(s) being investigated to determine the appropriateness of the sample size used.~~

X1.13 In general, hand mixing under ambient pressure will produce specimens with the shortest fatigue life. Other methods of mixing (for example, vacuum mixing and centrifugation) generally produce specimens with similar or greater fatigue life than hand-mixed specimens; however, exceptions to this have been reported [4, 14-17].

X2. SUGGESTED SPECIMEN MOLDING METHOD

X2.1 Scope

X2.1.1 This appendix provides a suggested fixture and method for molding cement specimens.

X2.2 Summary of Procedure

X2.2.1 A silicone mold is produced by curing liquid silicone around metal specimen masters. After curing, the specimen masters are removed to leave internal cavities in the mold with the intended cement specimen dimensions.

X2.2.2 Liquid cement is poured or injected into the cavities in the silicone mold, which is then placed on a water bath. The cement is allowed to polymerize and are then ejected from the mold to produce the cement specimens.

X2.3 Apparatus

X2.3.1 *Specimen Master*— A metallic blank which is machined to the specimen dimensions provided in Fig. 1. The master is used to produce the internal cavity of the final silicone mold.

X2.3.2 *Specimen Master Holder*—An assembly of two metal plates and four bolts (or equivalent) which is used to hold the specimen masters during the pouring and curing of the silicone mold. Suggested holder dimensions are provided in Fig. X2.1.

X2.3.3 *U-Channel*—an assembly consisting of three metal plates which form a trough with a U-shaped profile. Together with the specimen master holder, this forms the molding chamber. Suggested U-channel dimensions are provided in Fig. X2.2.

X2.3.4 *Molding Chamber*— the square internal cavity formed by the insertion of the specimen master holder into the U-channel. The walls of the U-channel along with the two end plates of the specimen master holder produce the chamber into which the silicone is poured during the fabrication of the mold.

X2.3.5 *Water Bath*— a chamber which is filled with water into which the mold is placed while the cement is polymerizing. The bath should have provisions for maintaining a constant temperature to an accuracy of $\pm 2^{\circ}\text{C}$.

X2.4 Preparation of Silicone Mold

X2.4.1 Several specimen masters are machined to the final dimensions as provided in Fig. 1. The finish should be $Ra = 0.4 \mu\text{m}$ or better.

X2.4.2 A number of specimen masters are placed into the specimen master holder such that they are sufficiently spaced apart from one another and then secured in the holder.

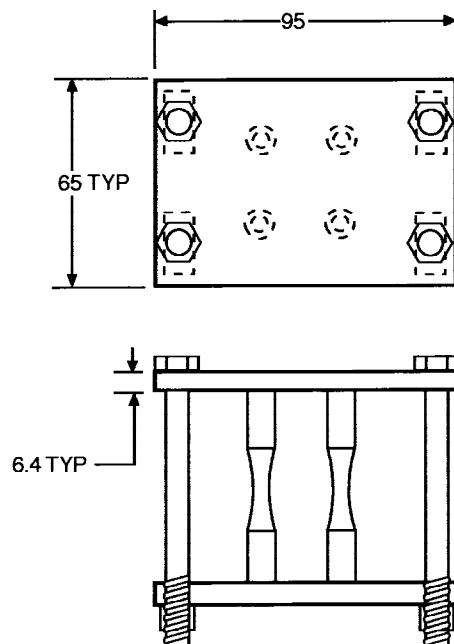

FIG. X2.1 Dimensions of Specimen Master Holder

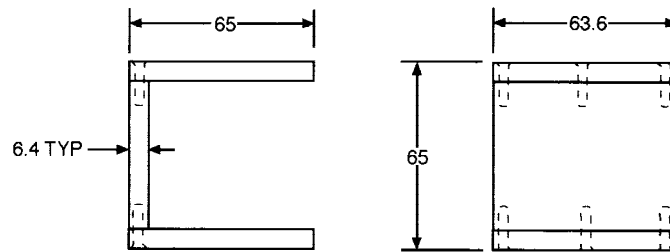

FIG. X2.2 Dimensions of U-Channel

X2.4.3 The holder with masters is turned on its side and inserted into the U-channel such that the two end plates of the master holder form the remaining two walls of the molding chamber. Any gaps between the master holder and U-channel should be filled with putty or appropriately sealed to prevent the substantial loss of silicone during molding.

X2.4.4 The molding chamber should be filled with a two-part silicone system to cover the specimen masters to a depth of at least 10 mm. The silicone should then be allowed to cure according to the manufacturer's instructions. Molding success with smooth surface finish and a mold that can be reused many times has been reported with silicone material of shore A durometer 29.

X2.4.5 After the silicone is cured, the silicone mold is removed from the molding chamber, and the specimen masters ejected by carefully pushing them from the mold with a blunt rod. The cavities formed by the specimen masters which remain in the mold are used for molding the cement specimens.

X2.5 Molding of Cement Specimens

X2.5.1 The silicone mold containing several internal cavities, prepared in X2.4, is used for molding of the cement specimens.

X2.5.2 The silicone mold is placed on a sheet of aluminum foil, with the axis of the specimen cavities oriented vertically.

X2.5.3 Bone cement is stored and mixed as described in 8.1. The fluid cement is poured or injected into the specimen cavities so that each cavity is slightly overfilled. The mold should be gently rocked during filling to permit egress of the air from the cavities.

X2.5.4 Once the cement has become sufficiently doughy, the molds are slipped from the aluminum foil, the excess cement is removed from the top of the mold, and the mold is placed into a water bath such that the mold is completely immersed. The temperature of the water bath shall be maintained at $37 \pm 2^\circ\text{C}$. The mold is removed from the bath after $1 \text{ h} \pm 15 \text{ min}$.

X2.5.5 The specimens are ejected by carefully pushing them from the mold with a blunt rod.

REFERENCES

- (1) Little, R.E. and Jebe, E.H., *Manual on Statistical Planning and Analysis for Fatigue Experiments*, STP 588, American Society of Testing and Materials, 1975.
- (2) Conway, J.B. and Sjodahl, L.H., *Analysis and Representation of Fatigue Data*, ASM International, Materials Park, OH, 1991.
- (3) Collins, J.A.: *Failure of Materials in Mechanical Design*, John Wiley & Sons, New York, 1981.
- (4) Lewis, G. and Austin, E., "Mechanical Properties of Vacuum-Mixed Acrylic Bone Cement," *Journal of Applied Biomaterials*, Vol. 5, pp. 307-314, 1994.
- (5) Lewis, G., "Properties of Acrylic Bone Cement: State of the Art Review," *Journal of Biomedical Materials Research (Applied Biomaterials)*, Vol. 38, pp. 155-182, 1997.
- (6) Sheskin, D.J., *Handbook of Parametric and Nonparametric Statistical Procedures*, CRC Press, Boca Raton, FL, 1997.
- (7) Wall, F.J., *Statistical Data Analysis Handbook*, McGraw-Hill, New York, 1986.
- (8) Kusy, R.P.: "Characterization of Self-Curing Acrylic Bone Cements," *Journal of Biomedical Materials Research*, Vol 12:271-305, 1978.
- (9) Johnson, J.A., Provan, J.W., Krygier, J.J., Chan, K.H., and Miller, J., "Fatigue of Acrylic Bone Cement - Effect of Frequency and Environment," *Journal of Biomedical Materials Research*, Vol. 23, pp. 819-831, 1989.
- (10) Verdonschot, N. and Huijskes, R., "Creep Behavior of Hand-Mixed Simplex P Bone Cement Under Cyclic Tensile Loading," *Journal of Applied Biomaterials*, Vol. 5, pp. 235-43, 1994.
- (11) Harrigan, T.P. and Harris, W.H., "A Three-Dimensional Non-Linear Finite Element Study of the Effect of Cement-Prosthesis Debonding in Cemented Femoral Total Hip Components," *Journal of Biomechanics*, Vol. 24, pp. 1047-58, 1991
- (12) Crowinshield, R.D., Brand, R.A., Johnston, R.C., and Milroy, J.C., "The Effect of Femoral Stem Cross-Sectional Geometry on Cement Stresses in Total Hip Reconstruction," *Clinical Orthopaedics and Related Research*, No. 147, pp. 71-77, 1980.
- (13) Topoleski, L.D.T., Ducheyne, P., and Cuckler, J.M., "A Fractographic Analysis of *In Vivo* Poly(methyl methacrylate) Bone Cement Failure Mechanisms," *Journal of Biomedical Materials Research*, Vol. 24, pp. 135-154, 1990.
- (14) Wixson, R.I., Lautenschlager, E.P., and Novak, M.A., "Vacuum Mixing of Acrylic Bone Cement," *Journal of Arthroplasty*, Vol. 2, No. 2, pp. 141-49, 1987.
- (15) Lidgren, L., Bodelind, B., and Moller, J., "Bone Cement Improved by Vacuum Mixing and Chilling," *Acta Orthopaedica Scandinavica*, Vol. 57, pp. 27-32, 1987.

- (16) Linden, U.: "Fatigue Properties of Bone Cement: A Comparison of Mixing Techniques," *Acta Orthopaedica Scandinavica*, Vol. 60, No. 4, pp. 431-33, 1989.
- (17) Davies, J.P., Jasty, M., O'Connor, D.O., Burke, D.W., Harrigan, T.P., and Harris, W.H., "The Effect of Centrifuging Bone Cement," *Journal of Bone and Joint Surgery [Br]*, Vol. 71B, No. 1, pp. 39-42, 1989.

ASTM International takes no position respecting the validity of any patent rights asserted in connection with any item mentioned in this standard. Users of this standard are expressly advised that determination of the validity of any such patent rights, and the risk of infringement of such rights, are entirely their own responsibility.

This standard is subject to revision at any time by the responsible technical committee and must be reviewed every five years and if not revised, either reapproved or withdrawn. Your comments are invited either for revision of this standard or for additional standards and should be addressed to ASTM International Headquarters. Your comments will receive careful consideration at a meeting of the responsible technical committee, which you may attend. If you feel that your comments have not received a fair hearing you should make your views known to the ASTM Committee on Standards, at the address shown below.

This standard is copyrighted by ASTM International, 100 Barr Harbor Drive, PO Box C700, West Conshohocken, PA 19428-2959, United States. Individual reprints (single or multiple copies) of this standard may be obtained by contacting ASTM at the above address or at 610-832-9585 (phone), 610-832-9555 (fax), or service@astm.org (e-mail); or through the ASTM website (www.astm.org).