



Standard Test Method for Determining Visible Abrasion Resistance of Glazed Ceramic Tile¹

This standard is issued under the fixed designation C 1027; the number immediately following the designation indicates the year of original adoption or, in the case of revision, the year of last revision. A number in parentheses indicates the year of last reapproval. A superscript epsilon (ϵ) indicates an editorial change since the last revision or reapproval.

1. Scope

1.1 This test method is designed to measure the resistance of tile surfaces to visible surface abrasion. Certain irregular surfaces may not be evaluated properly by this test method because of wear patterns.

1.2 The values stated in inch-pound units are to be regarded as the standard. The values given in parentheses are for information only.

1.3 This procedure does not make provisions for the apparent difference in abrasion values between light and dark colored tile.

1.4 This procedure does not optimally evaluate loss of gloss with abrasion.

1.5 *This standard does not purport to address all of the safety concerns, if any, associated with its use. It is the responsibility of the user of this standard to establish appropriate safety and health practices and determine the applicability of regulatory limitations prior to use.*

2. Referenced Documents

- 2.1 *ISO Standard:*
ISO 10545-14²

3. Significance and Use

3.1 The abrasion resistance of tile surfaces is determined by rotation of an abrasive load on the surface and the assessment of the resultant wear by means of visual comparison of the abraded test specimens and nonabraded tiles. A staining agent in light oil may be used to help determine whether abrasion surface is likely to result in mechanical entrapment of dirt particles.

¹ This test method is under the jurisdiction of ASTM Committee C21 on Ceramic Whitewares and Related Products and is the direct responsibility of Subcommittee C21.06 on Ceramic Tile.

Current edition approved April 1, 2004. Published May 2004. Originally approved 1984. Last previous edition approved in 1999 as C 1027 – 99.

² Available from American National Standards Institute (ANSI), 25 W. 43rd St., 4th Floor, New York, NY 10036.

4. Abrasive Load

4.1 The total load on each test specimen consists of the following:

- 4.1.1 Grade 25 chrome steel balls of various diameters:
 - 4.1.1.1 70.0 g of 5-mm diameter steel balls.
 - 4.1.1.2 52.5 g of 3-mm diameter steel balls.
 - 4.1.1.3 43.75 g of 2-mm diameter steel balls.
 - 4.1.1.4 8.75 g of 1-mm diameter steel balls.
- 4.1.2 3.0 g No. 80 grit aluminum oxide, and
- 4.1.3 20 ± 0.5 -mL demineralized water.

5. Reagents and Apparatus

5.1 *Abrasion Apparatus*—The abrasion apparatus shall consist of a steel case with a built-in electrical drive to a horizontal supporting plate with positions for a maximum of nine test specimens of dimensions at least 100 by 100 mm (see Fig. 1), but an apparatus with fewer positions may be used. The distance between the center of each position shall be 195 mm. There shall be equal distance between each adjacent position. The supporting plate rotates at 300 revolutions/min with an eccentricity of 22.5 mm so that every part of each test specimen describes a circular motion of 45-mm diameter. The test specimens are held down with the aid of metal holders, which are provided with rubber seals (see Fig. 2). The internal diameter of the holders is 83 mm, thus providing a test area of about 54 cm². The thickness of the rubber is 2.5 mm and the height of the space under the holder is 25.5 mm. The apparatus switches off automatically after completion of a preset number of revolutions. The supporting plate with holders and test specimens should have a cover during operation.

5.2 *Apparatus for Visual Assessment*—A viewing box (see Fig. 3) equipped with fluorescent lighting of color temperature 5000 to 6500K placed vertically above the surface to be observed providing 300-lux illumination. The interior of the box shall be painted a neutral gray.

5.3 *Drying Oven*, capable of operation at $(110 \pm 5)^\circ\text{C}$.

5.4 *10 % (v/v) Hydrochloric Acid Solution*, prepared by adding 263 mL of 38 % hydrochloric acid to 837 mL of distilled or demineralized water.

6. Test Specimen

6.1 *Types of Test Specimens*—Test specimens shall be representative of the sample. Where tiles have different colors or decorative effects in parts of the surface, care should be taken to include all distinctive parts.

6.2 The usual facial dimensions of test specimens are 4 by 4 in. (10 by 10 cm). Test specimens with smaller facial dimensions shall be fastened close together on a suitable supporting material. Edge effects at the narrow joints shall be ignored.

6.3 *Number of Test Specimens*—Eleven test specimens are required. Eight test specimens also are required for the visual assessment. The procedure requires one test specimen for each stage of abrasion, and subsequently, an additional three test specimens to verify the result at the visual fail point.

6.4 *Preparation*—The surfaces, of the test specimens to be tested, are to be clean and dry.

7. Procedure

7.1 *Abrasion Procedure*—Clamp a metal holder on to the glazed surface of each test specimen on the abrasion apparatus. Introduce the abrasive load, as described in Section 4, into the holder through the hole in its upper surface. The hole may be sealed to prevent loss from the abrasive load. The number of revolutions of the preset counter for each abrasion stage of the test is 100, 150, 600, 750, 1500, 2100, 6000, and 12 000.

7.1.1 After abrasion, rinse the test specimens under running water and dry in the oven at $(110 \pm 5)^\circ\text{C}$. If the test specimens are stained with iron oxide, they may be cleaned with 10 % (v/v) hydrochloric acid, as described in 5.4, before rinsing under running water and drying.

7.1.2 *Evaluation of Surface Abrasion*—For visual comparison, a viewing box, as described in 5.2, shall be used (see Fig. 3). The eight unabraded tile should be cleaned with a soft damp cloth to remove surface dust and after air drying should be placed in a hollow square pattern in the viewing box. The abraded tile should be placed in the center of the hollow square and the array of tile should be directly viewed from approximately 2 m (6.5 ft) at an angle of approximately 40° . The array should not be viewed for more than 10 s to avoid a studied observation of the surface. The lowest number of abrading cycles that show an apparent visual difference between the abrading tile and the unabraded tile shall be recorded.

7.1.3 The result is verified by retesting at the abrasion stage when failure is observed and the next higher and lower abrasion stages. If the result is not the same, the lower of the two abrasion stages shall be used to decide the classification. Abraded tiles, which have passed 1500, 2100, and 6000 revolution stages subsequently may be tested for stain resistance in accordance with the staining procedure in 7.2 (based on ISO 10545-14, pastes only) at which visual failure occurred. The abraded tile which has passed the 12 000 revolutions stage, subsequently shall be tested for stain resistance in accordance with the staining procedure in following section (based on ISO 10545-14).

7.1.4 After use, the metal bases and chrome steel ball bearings should be cleaned with water followed by methylated spirits and then thoroughly dried to prevent rusting.

7.2 *Cleaning Procedure*—The resistance to staining of the abraded tile surfaces is determined by maintaining test solutions and materials in contact with the proper surface of the tiles for a suitable length of time; the surface are then subjected to defined cleaning methods, and finally, inspected for visual change.

7.2.1 *Test Specimens*—Only one abraded tile is required for each of the abrasion stages to be tested.

7.2.2 *Staining Agents*—Green staining agent in light oil³ and red staining agent in light oil⁴ (for green-colored tile only).

7.2.3 *Cleaning Agents:*

7.2.3.1 *Hot Water.*

7.2.3.2 *Weak Cleaning Agent*, a commercial agent, not containing abrasive, with a pH of 6.5 to 7.5.

7.2.3.3 *Strong Cleaning Agent*, a commercial cleaning agent containing abrasive, with a pH of 9 to 10.

7.2.4 *Suggested Solvents:*

7.2.4.1 3 % (v/v) *HCl Solution*, prepared from 38 % hydrochloric acid by adding 79 mL of the reagent hydrochloric acid solution to 951 mL of distilled water.

7.2.4.2 20 % *KOH Solution (200 g/L)*, prepared by dissolving 200 g of 90 % potassium hydroxide crystals in 1 L of water.

7.2.4.3 *Acetone*, technical grade.

7.3 *Application of the Staining Agent*—Lightly rub three to four drops of the staining agent paste on the abraded surface and cover with a 30-mm convex watch glass to allow the staining agent to spread in a circular pattern. Allow the staining agent to remain in contact with the abraded tile surface for 24 h.

7.4 *Cleaning Procedure:*

³ Green staining agent is a paste consisting of 40 % by mass commercial grade of chrome oxide, Cr_2O_3 (95 % + chrome oxide) of the following approximate particle size distribution, suspended in propanetriol monodecanoate dioctanoate available as Myritol 318 from Henkel. Premixed staining agent is available from Gabrielli, PO Box 218, Sesto Fiorentino 50019, Italy.

%<	μm
10.0	0.5
29.2	1.0
43.7	2.0
50.0	3.0
66.3	5.0
78.8	10.0
89.6	20.0
93.0	32.0
97.4	64.0
100.0	96.0

⁴ Red staining agent is a paste consisting of 40 % by mass commercial grade of iron oxide, Fe_2O_3 (95 % + iron oxide) of the following approximate particle size distribution, suspended in propanetriol monodecanoate dioctanoate available as Myritol 318 from Henkel Corp., 300 Brookside Ave., Ambler, PA 19002. Premixed staining agent is available from Gabrielli.

%<	μm
51.3	0.5
53.9	1.0
71.0	2.0
82.2	3.0
88.3	5.0
88.8	10.0
96.5	20.0
96.5	32.0
100.0	64.0

7.4.1 *Stain Removal Attempts*—The test specimens, treated according to 7.3, are treated successively to the cleaning procedures reported in 7.4.2-7.4.5. After each cleaning procedure, the specimens are dried in an oven at $(110 \pm 5)^{\circ}\text{C}$ and then subjected to visual examination. The specimens are inspected at a distance of 25 to 30 cm. Daylight or artificial illumination is permitted at approximately 300 lux, but direct sunlight shall be avoided. Staining only shall be reported when the pigments are visible.

7.4.2 *Procedure A*—Flow of running hot water for 5 min; the surface then is wiped with a damp cloth.

7.4.3 *Procedure B*—Hand cleaning with the weak cleaning agent (see 7.2.3.2). A natural, nonabrasive sponge or a cloth can be used. The surface then is rinsed with running water and finally wiped with a damp cloth.

7.4.4 *Procedure C*—Mechanical cleaning, such as a rotating brush, having a 8-cm diameter with hard bristles and automatic cleaning agent feed using the strong cleaning agent (see 7.2.3.3). The cleaning action is applied for approximately 2 min and then the surface is rinsed with running water and finally wiped with a damp cloth.

7.4.5 *Procedure D*—Immersion for 24 h of the test specimens in suitable solvent that is capable of removing the stain.

8. Classification of Results

8.1 The test specimens are classified according to Table 1. To be classified as Class V, the tile also must pass the staining procedure in Section 6.4 (based on ISO 10545-14). If there is no visual failure at 12 000 revolutions, but the stain cannot be

removed by any of the procedures listed in 6.4, the tile shall be classified as Class IV.

9. Report

9.1 The report shall reference this test method and provide the following information:

- 9.1.1 A description of the tiles;
- 9.1.2 The preparation of test specimens;
- 9.1.3 The classification according to 7.1.1; and
- 9.1.4 The abrasion stage at which visual failure occurred according to 7.1.1.

10. Precision and Bias

10.1 Precision and bias currently are being developed by Subcommittee C21.06.

11. Keywords

11.1 abrasion resistance; glaze durability; viewing box; visual abrasion

TABLE 1 Classification of Tile

Abrasion Stage at Which the Failure is Visible	Class
100	Class 0
150	Class I
600	Class II
750	Class III
1 500	Class III
2 100	Class IV
6 000	Class IV
12 000	Class IV
>12 000 and pass staining test	Class V

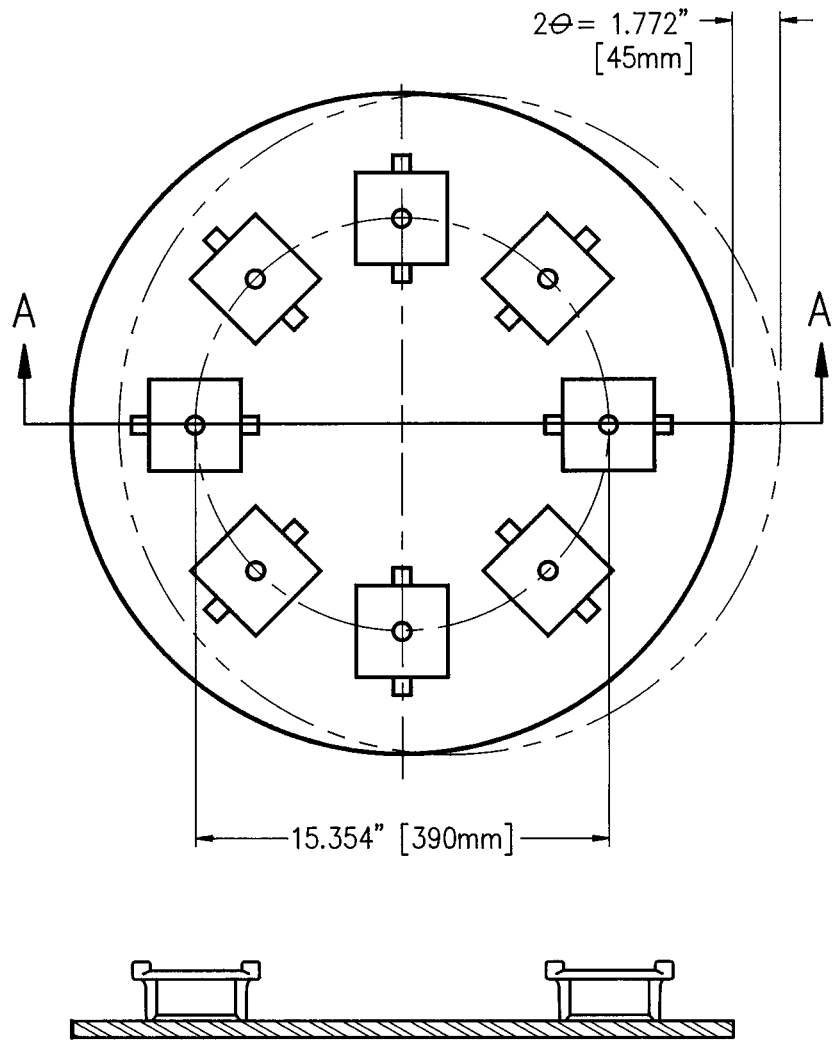

FIG. 1 Top View of the Abrasion Tester

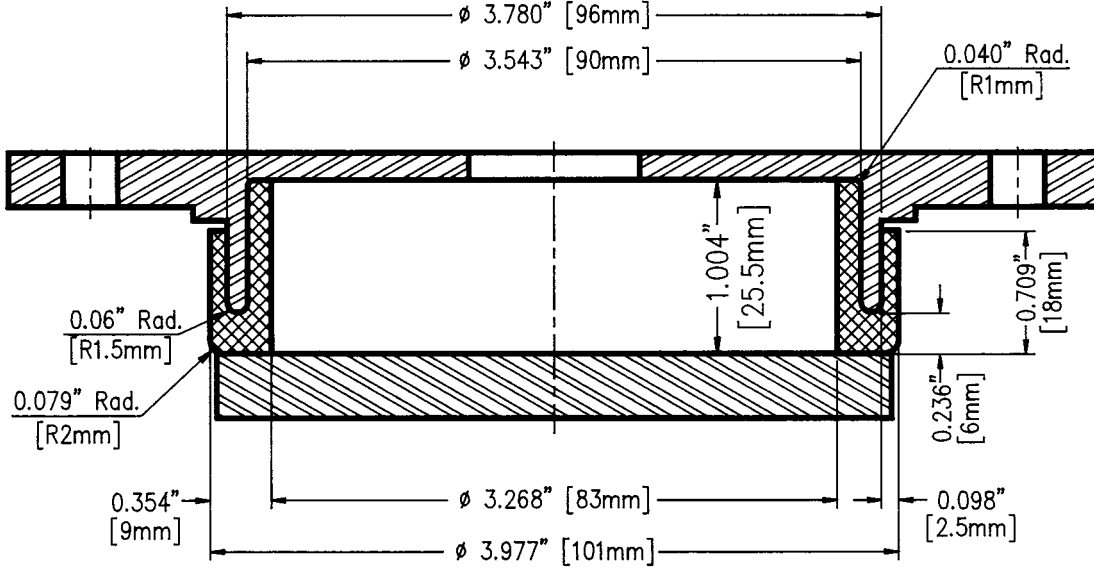
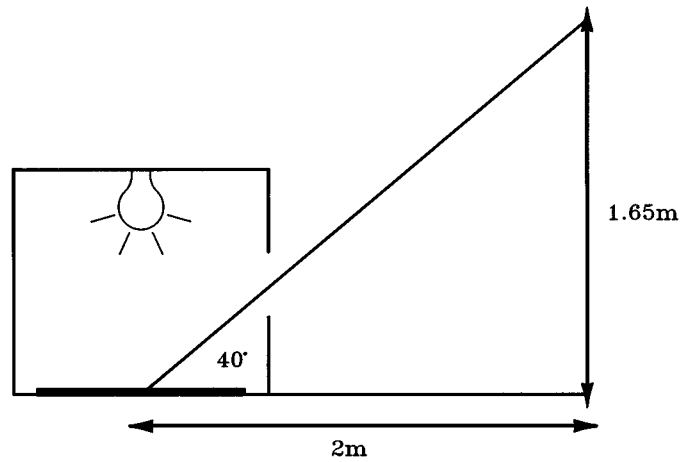



FIG. 2 Side View of the Abrasion Tester



NOTE 1—Box 24 by 24 by 24 in. (61 by 61 by 61 cm). Plan 24 by 24 in. (61 by 61 cm). Light source screened to avoid direct viewing, 300-lux illumination on the tiles, inner faces of box painted gray.

FIG. 3 Viewing Box Setup

 **C 1027 – 99 (2004)**

ASTM International takes no position respecting the validity of any patent rights asserted in connection with any item mentioned in this standard. Users of this standard are expressly advised that determination of the validity of any such patent rights, and the risk of infringement of such rights, are entirely their own responsibility.

This standard is subject to revision at any time by the responsible technical committee and must be reviewed every five years and if not revised, either reapproved or withdrawn. Your comments are invited either for revision of this standard or for additional standards and should be addressed to ASTM International Headquarters. Your comments will receive careful consideration at a meeting of the responsible technical committee, which you may attend. If you feel that your comments have not received a fair hearing you should make your views known to the ASTM Committee on Standards, at the address shown below.

This standard is copyrighted by ASTM International, 100 Barr Harbor Drive, PO Box C700, West Conshohocken, PA 19428-2959, United States. Individual reprints (single or multiple copies) of this standard may be obtained by contacting ASTM at the above address or at 610-832-9585 (phone), 610-832-9555 (fax), or service@astm.org (e-mail); or through the ASTM website (www.astm.org).