



Standard Test Method for Non-Destructive Photoelastic Measurement of Edge and Surface Stresses in Annealed, Heat-Strengthened, and Fully Tempered Flat Glass¹

This standard is issued under the fixed designation C 1279; the number immediately following the designation indicates the year of original adoption or, in the case of revision, the year of last revision. A number in parentheses indicates the year of last reapproval. A superscript epsilon (ϵ) indicates an editorial change since the last revision or reapproval.

1. Scope

1.1 This test method covers the determination of edge stresses and surface stresses in annealed, heat-strengthened, and fully tempered flat glass products.

1.2 This test method is non-destructive.

1.3 This test method uses transmitted light and is, therefore, applicable to light-transmitting glasses.

1.4 The test method is not applicable to chemically-tempered glass.

1.5 Using the procedure described, surface stresses can be measured only on the “tin” side of float glass.

1.6 Surface-stress measuring instruments are designed for a specific range of surface index of refraction.

1.7 *This standard does not purport to address all of the safety concerns, if any, associated with its use. It is the responsibility of the user of this standard to establish appropriate safety and health practices and determine the applicability of regulatory limitations prior to use.*

2. Referenced Documents

2.1 ASTM Standards:

C 162 Terminology of Glass and Glass Products²

C 770 Test Method for Measurements of Glass Stress-Optical Coefficient²

C 1048 Specification for Heat-Treated Glass: Kind HS, Kind FT Coated and Uncoated Glass²

F 218 Test Method for Analyzing Stress in Glass

2.2 Other Documents:

*Engineering Standards Manual*³

“Surface and Edge Stress in Tempered Glass”⁴

3. Terminology

3.1 Definitions:

3.1.1 *analyzer*—a polarizing element, typically positioned between the specimen being evaluated and the viewer.

¹ This test method is under the jurisdiction of ASTM Committee C-14 on Glass and Glass Products and is the direct responsibility of Subcommittee C14.08 on Flat Glass.

Current edition approved Aug. 15, 1994. Published October 1994.

² *Annual Book of ASTM Standards*, Vol 15.02.

³ Available from Glass Tempering Association, 3310 Harrison, Topeka, Kansas.

⁴ Redner, A. S. and Voloshin, A. S., *Proceedings of the Ninth International Conference on Experimental Mechanics*, Denmark, 1990.

3.1.2 *polarizer*—an optical assembly that transmits light vibrating in a single planar direction, typically positioned between a light source and the specimen being evaluated.

3.1.3 *retardation compensator*—an optical device, variants of which are used to quantify the optical retardation produced in transparent birefringent materials: typically positioned between the specimen being evaluated and the analyzer.

3.2 For definition of terms used in this test method, refer to Terminology C 162.

4. Summary of Test Methods

4.1 Two test methods are described in this standard:

4.1.1 *Procedure A* describes a test method for measuring surface stress using light propagating nearly parallel to the surface.

4.1.2 *Procedure B* describes a test method for measuring edge-stress using light propagating in the direction perpendicular to the surface.

4.2 In both methods, the fundamental photoelastic concept is used. As a result of stresses, the material becomes optically anisotropic or birefringent. When polarized light propagates through such anisotropic materials, the differences in the speed of light rays vibrating along the maximum and minimum principal stress introduce a relative retardation between these rays. This relative retardation is proportional to the measured stresses, and can be accurately determined using compensators. For additional background see “Surface and Edge Stress in Tempered Glass”.

5. Significance and Use

5.1 The strength and performance of heat-strengthened and fully-tempered glass is greatly affected by the surface and edge stress induced during the heat-treating process.

5.2 The edge and surface stress levels are specified in Specification C 1048, in the Engineering Standards Manual of GTA and in foreign specifications.

5.3 This test method offers a direct and convenient way to non-destructively determine the residual state of stress on the surface and at the edge of annealed and heat-treated glass.

6. Principles of Operation

6.1 Procedure A: Measuring Surface Stress:

6.1.1 Measurement of surface stresses requires an optical

apparatus that permits the injection of polarized light rays propagating in a thin layer adjacent to the surface (see Note 1). A prism is usually used for this purpose. The rays emerge at critical angle i_c . The photoelastic retardation due to the surface stresses, (see Fig. 1), is measured using a wedge-compensator.

6.1.2 The incident light beam should be arriving at the critical angle i_c and polarized at 45° to the entrance of the prism edge. A quartz wedge-compensator, W_c , placed in the path of emerging light adds a retardation, R_c , to the retardation R_s induced by stresses in the surface of the specimen. The analyzer, A , placed between the eyepiece, E , and the wedge-compensator, W_c , generates a visible set of fringes or lines of constant retardation R where

$$R = R_s + R_c \quad (1)$$

Since the specimen-induced retardation is proportional to the surface stress, S , and the path, t , we have:

$$R_s = C \cdot S \cdot t = C \cdot S \cdot aX \quad (2)$$

where:

- R = is the relative retardation,
- C = stress-optical constant (see Note 2),
- S = surface stress in the direction perpendicular to the path, t
- t = path of light traveling between the entrance and exit points 1, 2 (Fig. 1),
- a = Geometrical factor, (depending upon the prism design) $a = t/X$. This constant is determined by the manufacturer.

6.1.3 The compensator adds its own retardation. It is linearly variable along its length y and is calculated as

$$R_c = b \cdot y \quad (3)$$

Where b is a constant, determined by the manufacturer of the compensator. The observer sees in the compensator plane a total retardation R .

$$R = R_s + R_c = a \cdot C \cdot S \cdot x + b \cdot y \quad (4)$$

6.1.4 The fringes (lines of $R = \text{Constant}$) are, therefore, tilted lines. (See Fig. 2). The angle θ is the tilt of these fringes relative to a plane containing the light path of Fig. 1 and Fig. 2. The measured stress is proportional to the tangent of the tilt

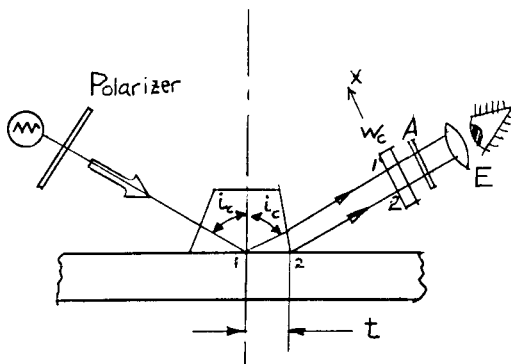

FIG. 1 Apparatus For Measuring Surface Stress

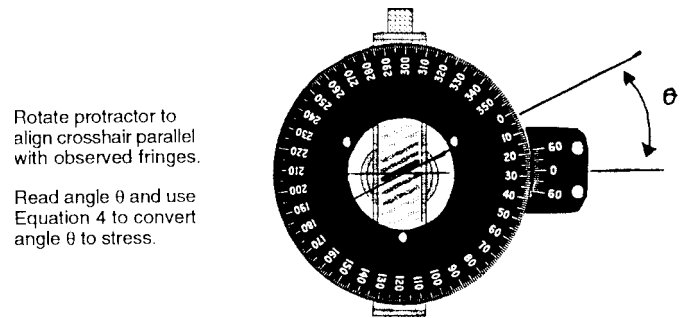

FIG. 2 Fringes Observed in the Plane of the Compensator

angle θ , measured using a goniometer, and to an instrument calibration constant, K MPa (psi), determined by the manufacturer.

$$\tan \theta = \frac{a \cdot C \cdot S}{b} \quad \text{and} \quad (5)$$

$$\text{Stress} = \frac{b}{C \cdot a} \cdot \tan \theta = K \cdot \tan \theta$$

In the actual procedure (see 9.1 below) the operator measures the tilt angle θ of the observed set of fringes.

NOTE 1—The surface-stress measuring apparatus described in this section is manufactured by Strainoptic Technologies, Inc. in North Wales, Pennsylvania.

NOTE 2—The stress constant of float glass is typically 2.55 to 2.65 Brewsters. Calibration can be performed using one of the test methods described in Test Methods C 770.

6.2 Procedure B: Measuring Edge Stress:

6.2.1 Measurement of edge stress is accomplished using a polarimeter equipped with a wedge-compensator, as shown schematically in Fig. 3.

6.2.2 The angle between the polarizer and the edge of the specimen must be 45° (see Fig. 3a), and the analyzer must be perpendicular to the polarizer. The overall magnification should be at least $20\times$ to permit clear visibility of the reticle, and of photoelastic fringes near the edge. The reticle placed adjacent to the specimen must have graduations of 0.1 mm (0.004 in.) or smaller. The resolution of the compensator should be at least 5 nm, and the compensator should be

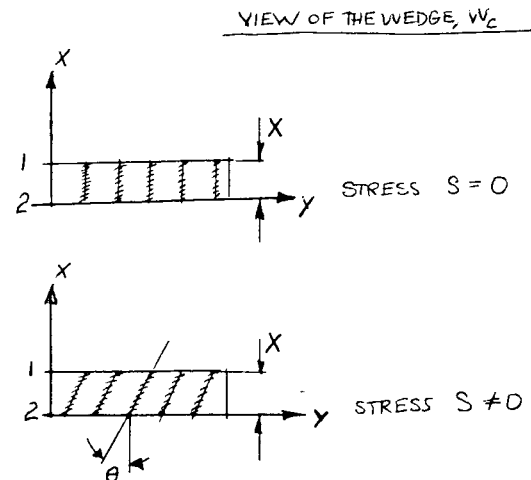

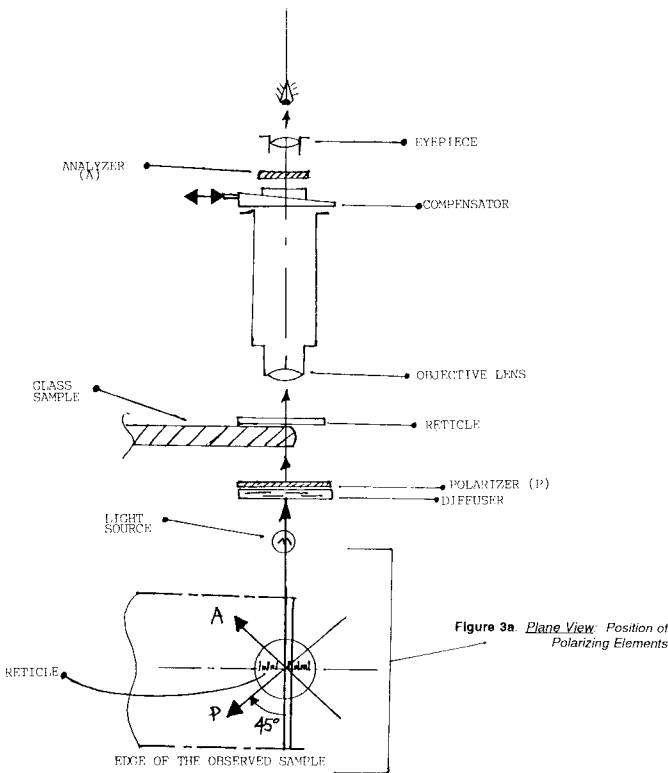

FIG. 3 Schematic of the Instrument for Measuring Edge Stress

calibrated by the manufacturer at 565 nm wavelength with results of calibration expressed in nm/div.

6.2.3 The compensator used could be of linear wedge type (Babinet) or uniform-field type (Babinet-Soleil). The linear-wedge type requires a reticle placed adjacent to the compensator wedge and a linear-motion scale, or lead screw, locating the wedge position with reference to the reticle.

6.2.4 The uniform field does not require a reticle, and must be equipped with a lead screw measuring the relative motion of its wedges.

7. Sampling

7.1 *Procedure A: Measuring Surface Stress*—The number of points to be measured are determined by the product specification.

7.2 *Procedure B: Measuring Edge Stress*—Readings must be obtained at the mid-span point of every edge.

8. Conditioning

8.1 In order to avoid thermal stresses, the specimen should be allowed to reach ambient temperature throughout its entire mass prior to testing.

9. Procedure

9.1 *Procedure A—A Measuring Surface Stress:*

9.1.1 Clean the surface of any trace of oil or other chemical deposits.

9.1.2 Place a few drops of index liquid on the tin side surface of the specimen at the point of interest. The index of refraction of the liquid should be higher than the index of the examined glass and lower or equal to the index of the prism.

9.1.3 Perform the adjustments of the optical path in accordance with manufacturer's specifications to obtain a clear image of an equally-spaced set of fringes in the compensator plane.

9.1.4 Using the goniometer, measure the angle θ (in degrees) of these fringes to the plane of symmetry (see Fig. 2).

9.1.5 In all instances where the surface stress is uniform (independent of direction), measure the angle θ , orienting the instrument's plane of symmetry to measure stress parallel to the nearest edge.

9.1.5.1 In those instances where the direction of maximum and minimum stress is uncertain (as a result of irregular geometry, proximity of edges, or non-uniformity of heat-treating process), orient the instrument along direction α_1 , α_2 , α_3 , and measure the fringe pattern angle θ_1 , θ_2 , θ_3 , in degrees, for each direction. Select α_1 , α_2 , α_3 as follows:

α_1 parallel to the nearest edge,

α_2 45° to the nearest edge, and

α_3 perpendicular to the nearest edge. (See Fig. 4)

9.2 *Procedure B—Measuring Edge Stress:*

9.2.1 Place the instrument in position, with a measuring reticle placed adjacent to instrument, and in close contact with the edge of glass.

9.2.2 Using the reticle graduation, measure the depth, d , in mm (in.), of the seamed or beveled region, which is non-transmitting. If the depth of the beveled region, d (see Fig. 5), is less than 0.25 mm (0.010 in.), use visual extrapolation of the observed fringe pattern (see 9.2.3). When the depth is equal to or greater than 0.25 mm (0.010 in.), use the extrapolation equation (see 9.2.5).

9.2.3 *Measurement Using Visual Extrapolation*—Observe the pattern of photoelastic fringes near the edge of the specimen (see Fig. 6a and Fig. 6b). Adjust the wedge (or double wedge) until the black fringe arrives to the edge (double wedge, Fig. 6b), or crosses the edge at the crosshair (single wedge, Fig. 6a).

9.2.4 Obtain a reading (R_e) using a single or double wedge, at the center of each edge of the glass.

9.2.5 *Measurement Using an Extrapolation Equation*—In case the seamed edge makes the reading at the edge difficult [$d > 0.25$ mm (0.01 in.)], measurement of retardation R (nm) at two points, x_1 and x_2 (Fig. 6b), of the reticle scale must be made. These points are to be selected per Table 1. The retardations R_1 and R_2 (nm) are retardation values measured using the compensator scale at the points X_1 and X_2 . The edge retardation R_e (nm) is obtained from the equation:

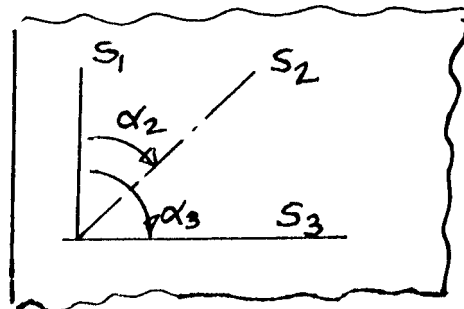

FIG. 4 Orientation of the Instrument for Measuring Surface Stress

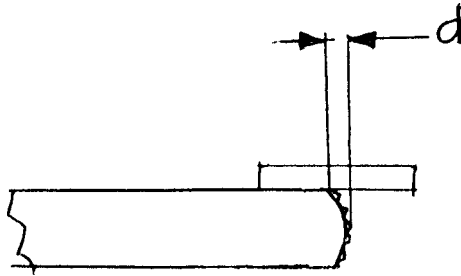

FIG. 5 Depth Measurement of Beveled Region

$$R_e = 3.8 \cdot R_1 - 2.8 \cdot R_2 \quad (6)$$

9.2.6 Using a micrometer, measure the thickness of the specimen at the location where the stress is measured.

10. Calculation and Interpretation

10.1 *Procedure A: Measuring Surface Stress*—When the measured angle is obtained using procedure 9.1.5, calculate the surface stress, s , using:

$$S = K \tan \theta \quad (7)$$

where K is the instrument calibration constant determined by the manufacturer, in MPa (psi).

10.1.1 In those instances where the surface stress is directional, assess the state of stress by comparing the reading S in three directions $\alpha_1, \alpha_2, \alpha_3$. If all three directions yield the same measured angles $\theta_1, \theta_2, \theta_3$ within 1° , calculate the average angle, then obtain the surface stress from Eq 8 and Eq 9.

$$\theta_{\text{average}} = \frac{\theta_1 + \theta_2 + \theta_3}{3} \quad (8)$$

$$S = K \cdot \tan \theta_{\text{average}} \quad (9)$$

If the measured angles θ_1, θ_2 , and θ_3 differ by more than 1° , then using Eq 7, obtain the three stresses S_1, S_2 , and S_3 in directions α_1, α_2 , and α_3 , and then calculate the principal stresses S_{max} , and S_{min} , from Eq 10 and Eq 11.

$$S_{\text{max}} = \frac{S_1 + S_3}{2} + \frac{\sqrt{2}}{2} \sqrt{(S_1 - S_2)^2 + (S_2 - S_3)^2} \quad (10)$$

$$S_{\text{min}} = \frac{S_1 + S_3}{2} - \frac{\sqrt{2}}{2} \sqrt{(S_1 - S_2)^2 + (S_2 - S_3)^2} \quad (11)$$

10.2 *Procedure B: Measuring Edge Stress*—From the measured retardation R_e calculate the edge stress (in psi):

$$S_e = \frac{R_e \cdot b}{t C_B} \quad (12)$$

TABLE 1 Thickness of Glass

	1/8 to 3/16 inch (3 to 5 mm)	1/4 to 3/8 inch (6 to 10 mm)	1/2 to 1 inch (12 to 24.5 mm)
x_1	0.6 or 0.8 mm	1.0 mm	2.0 mm
x_2	1.0 or 1.3 mm	1.6 mm	3.0 mm

where:

R_e = the wedge reading (nm),

t = the thickness of the glass sample (mm, in.),

C_B = stress-optical constant, Brewsters (1 Brwstr. = 10^{-12} /Pa or nm/psi-in.),

S_e = stress MPa (psi), and

b = compensator constant determined by manufacturer.

11. Report

11.1 At a minimum, the report must contain:

11.1.1 Date of specimen manufacture

11.1.2 Identification of specimen (material)

11.1.3 Selected procedure

11.1.4 Glass thickness

11.1.5 For surface measurement:

11.1.5.1 Location(s) of measurement(s)

11.1.5.2 Direction of measurement(s)

11.1.5.3 Values of $\theta_1, \theta_2, \theta_3$ at each location and the calculated stress

11.1.6 For edge measurements:

11.1.6.1 Location of measurement(s)

11.1.6.2 Chamfer size

11.1.6.3 Thickness of specimen at point of measurement

11.1.6.4 Extrapolation method used—*visual* (9.2.3) or *calculated* (9.2.4)

11.1.6.5 Average edge stress

12. Precision and Bias

12.1 The precision and bias of this method will be determined by a round-robin test conducted by subcommittee C14.08.

13. Keywords

13.1 annealed glass; heat-strengthened glass; polariscopic examination; stress measurement; tempered glass

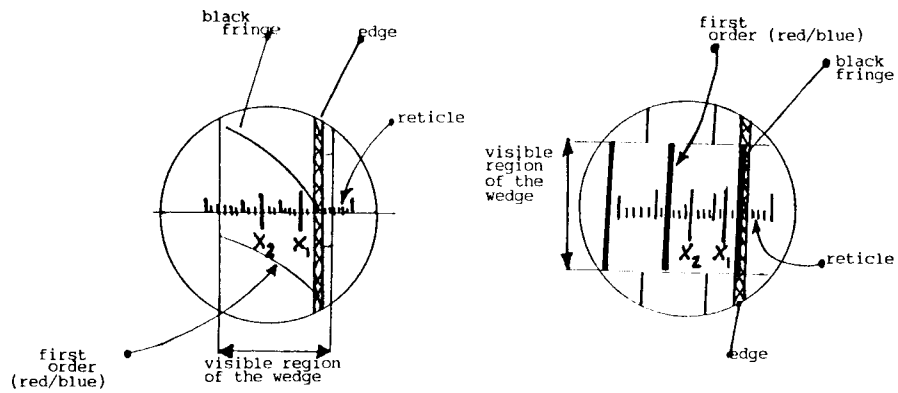

FIG. 6 a) Fringes Observed Using Wedge Compensator (Babinet), b) Fringes Observed Using Double Wedge Compensator (Babinet-Soleil)

The American Society for Testing and Materials takes no position respecting the validity of any patent rights asserted in connection with any item mentioned in this standard. Users of this standard are expressly advised that determination of the validity of any such patent rights, and the risk of infringement of such rights, are entirely their own responsibility.

This standard is subject to revision at any time by the responsible technical committee and must be reviewed every five years and if not revised, either reapproved or withdrawn. Your comments are invited either for revision of this standard or for additional standards and should be addressed to ASTM Headquarters. Your comments will receive careful consideration at a meeting of the responsible technical committee, which you may attend. If you feel that your comments have not received a fair hearing you should make your views known to the ASTM Committee on Standards, 100 Barr Harbor Drive, West Conshohocken, PA 19428.