



Standard Test Method for Calibration of Surface/Stress Measuring Devices¹

This standard is issued under the fixed designation C 1377; the number immediately following the designation indicates the year of original adoption or, in the case of revision, the year of last revision. A number in parentheses indicates the year of last reapproval. A superscript epsilon (ϵ) indicates an editorial change since the last revision or reapproval.

1. Scope

1.1 This test method covers calibration or verification of calibration or both, of surface-stress measuring devices used to measure stress in annealed and heat-strengthened or tempered glass, using polariscopic or refractometry based principles.

1.2 This test method is nondestructive.

1.3 This test method uses transmitted light, and therefore, is applicable to light-transmitting glasses.

1.4 This test method is not applicable to chemically tempered glass.

1.5 Using the procedure described, surface stresses can be measured only on the “tin” side of float glass.

1.6 *This standard does not purport to address all of the safety concerns, if any, associated with its use. It is the responsibility of the user of this standard to establish appropriate safety and health practices and determine the applicability of regulatory limitations prior to use.*

2. Referenced Documents

2.1 ASTM Standards:

C 158 Test Methods for Strength of Glass by Flexure/termination of Modulus of Rupture²

C 162 Terminology of Glass and Glass Products²

C 770 Test Method for Measurements of Glass Stress—Optical Coefficient²

C 1048 Specification for Heat-Treated Flat Glass—Kind HS, Kind FT Coated and Uncoated Glass²

C 1279 Test Method for Nondestructive Photoelastic Measurement of Edge and Surface Stresses in Annealed, Heat-Strengthened, and Fully Tempered Flat Glass²

3. Terminology

3.1 *Definitions*—For terminology used in this test method, refer to Terminology C 162.

4. Summary of Test Method

4.1 In this test method, a test bar is subjected to bending using deadweights or calibrated load-cells to introduce surface stresses that can be calculated from the specimen geometry and

forces applied. At a point in which the stresses are calculated, those same stresses also are measured using the instrument to be calibrated or verified. Since both the specimen dimension and the applied forces can be established accurately using traceable (primary) standards, the method permits a fully traceable calibration of the stress-measuring instrument.

5. Significance and Use

5.1 The strength and performance of heat-strengthened and fully tempered glass is greatly affected by the surface and edge stress induced during the heat-treating process.

5.2 The edge and surface stress levels are specified in Specification C 1048, in the Engineering Standards Manual of GANA³, and in foreign specifications.

5.3 Surface stresses can be measured nondestructively using methods, such as Test Method C 1279. The calibration of surface measuring devices used in those procedures and periodic verification of calibration are needed. This test method offers a convenient way to accomplish this task.

6. Principle of Operation

6.1 The instrument to be calibrated is placed on the surface of the calibration specimen. Stresses at a point where the instrument is placed are calculated using expressions shown in Section 9. To increase the precision of measurement, several levels of stress are produced by applying forces incrementally. Measurement of stress using the instrument to be calibrated is repeated for each stress level and these measurements are used to calibrate the instrument.

7. Test Specimens and Loading Schemes

Two loading geometries can be practiced: cantilever and four-point bending.

7.1 *Cantilever-Beam Specimen (Fig. 1)*—the dimensions of the specimen used for cantilever loading should be selected within limits shown below:

Thickness (t): 6 mm (0.22 in.) minimum
Width (w): $8t \leq w \leq 12t$
Length (L): $6w$ minimum
Distance to the point of measurement (L_0): $4w$
Clamped length: $1.5w$

7.1.1 A heat-strengthened or tempered specimen, with polished edges is preferred, but annealed specimens can be used if the range of stress is less than 24.13 MPa (3500 psi).

¹ This test method is under the jurisdiction of ASTM Committee C-14 on Glass and Glass Products and is the direct responsibility of Subcommittee C14.08 on Flat Glass.

Current edition approved Oct. 10, 1997. Published February 1998.

² *Annual Book of ASTM Standards*, Vol 15.02.

³ GANA, Glass Association of North America, 3310 SW Harrison St., Topeka, KS 66611-2279.

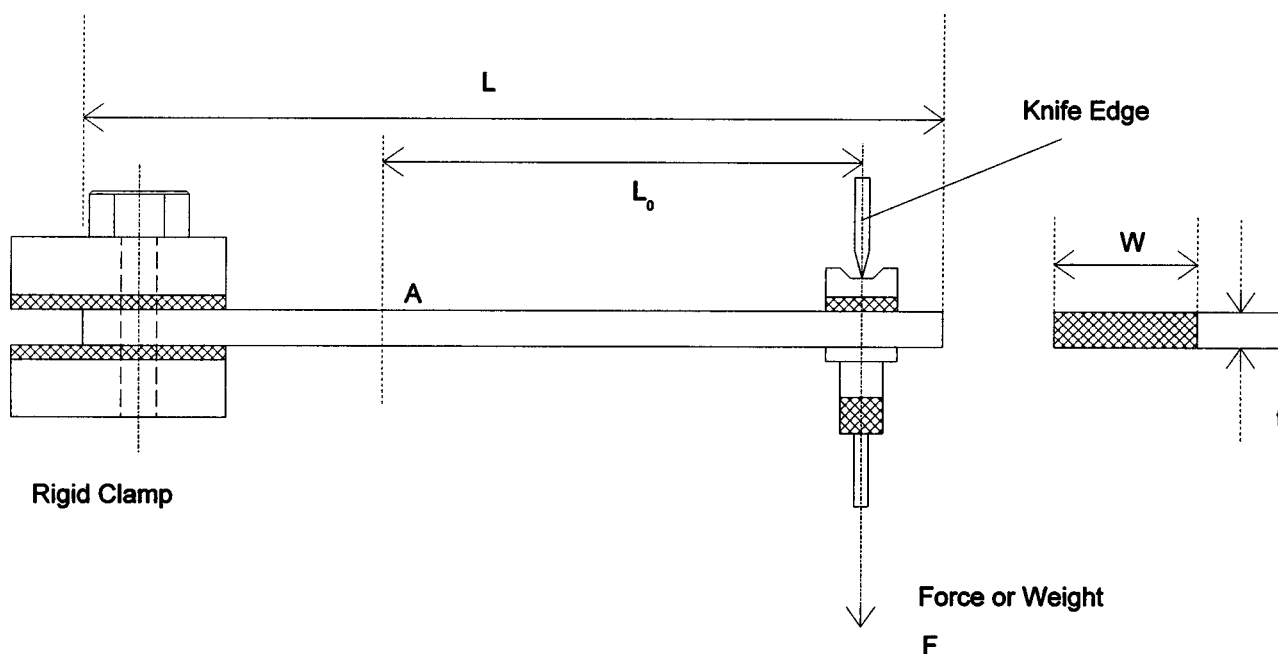

FIG. 1 Cantilever Beam Loading

7.2 *Four-Point Bending Specimen* (Fig. 2)—The four-point bending specimen should be preferred since it has uniform stress in the central loading zone. The dimensions of the specimen should be selected within the following limits:

- Thickness (t): minimum 2 mm (0.079 in.)
- Width (w): $8t \leq w \leq 12t$ (see Note 1)
- Length L_0 : minimum $4w$
- Gage length L_c section: $3w$
- Minimum overall length L : $12w$
- Edges: Polished, no chips in the gage section, bevel less than $0.1t$.

NOTE 1—When the thickness t is less than 6 mm, and width of the beam exceeds $12t$, instead of the beam bending, plate bending equations should be used to calculate surface stress, or suitable corrections are required in the equations in 9.1. Barata⁴ and Ashwell⁵ show the correction procedures.

7.3 *Application of Forces*—Forces required must be calculated to eliminate possible breakage. Stresses must be estimated first using the equations in 9.1. A tempered specimen may be subjected to stress levels up to 10 000 psi (69 MPa). Using annealed specimens, the stress should remain at a safe level, typically below 3500 psi (24 MPa).

7.3.1 *Cantilever Specimen*—The specimen must be clamped securely using wood, plastic, or rubber-lined metal clamping surfaces, with rounded edges, as shown in Fig. 3. The forces can be applied using a calibrated testing machine or dead weights, by means of knife edges, to insure exact positioning of the line-of-loading B-B. The pad used for load application can be secured from slipping using high-friction materials. To eliminate possible twisting action, the knife edge should be narrow, or a steel ball used to center the point of application of force.

7.3.2 *Four-Point Bending Specimen*—In the case of four-point bending, the force must be applied equally at two points,

and two articulated knives or roller supports are required to ascertain accurately the length L_0 and L_c . Particular precautions are required to insure that the end supports do not introduce a twist in the specimen, as a result of nonparallel support surfaces or nonflatness of the specimen itself. Fig. 2 illustrates the setup for application of forces to obtain tension and compression on the upper face. Test Methods C 158 provides a description of support design.

8. Procedure

8.1 When calibrating a surface polarimeter, apply forces in five equal increments, using a testing machine or dead weight. When calibrating a critical angle measuring instrument, at least ten increments are needed, and a tempered specimen must be used.

8.2 For each incremental loading, including zero, obtain the instrument reading. Repeat the reading at least three times, and average the readings. When calibrating a surface polarimeter, measure the fringe tilt θ . When calibrating a differential refractometer, measure the differential angle using a micrometer reticle, and read the distance between the borders of illuminated zones at mutually perpendicular polarization in accordance with instrument manual.

8.3 Prepare a table of results, and plot these data, with applied stress as the ordiant (x axis) and $\tan \theta$ (using surface polarimeter) or angular distance between emerging light beams (using refractometer) versus applied stress (see Fig. 4).

9. Calculation

9.1 For each force increment, calculate the stress at Point A where measurements are obtained using the following formula:

$$\text{Stress}_{(\text{psi})} = \text{FORCE}_{(\text{lbs})} \times \frac{6 L_0(\text{in.})}{w_{\text{in.}} t_{\text{in.}}^2} \quad (1)$$

or

⁴ Barata, F. I., "When Is a Beam a Plate?," *American Ceramic Society Communications*, May 1981.

⁵ Ashwell, D. G., "The Anticlastic Curvature of Rectangular Beams and Plates," *Journal of Aeronautics*, Vol 54, 1950, pp. 708-715.

ASTM C 1377

Upper Surface in Compression

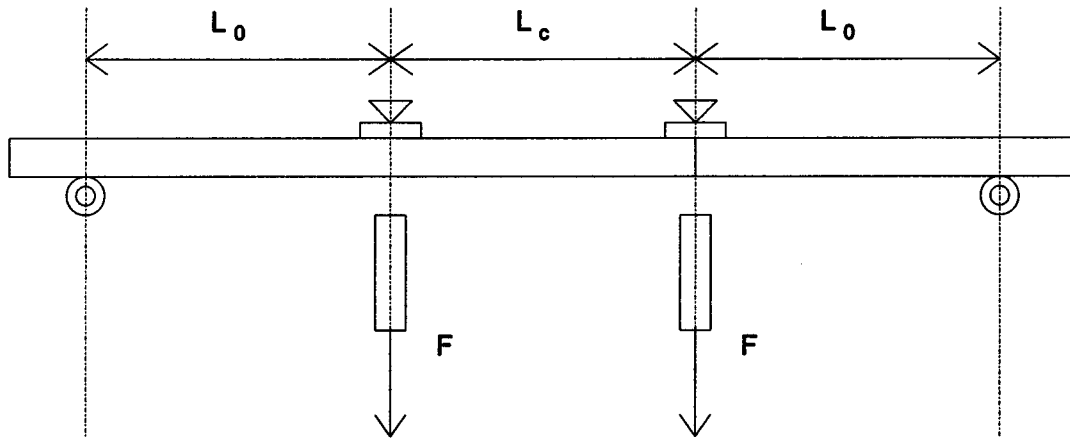

Upper Surface in Tension

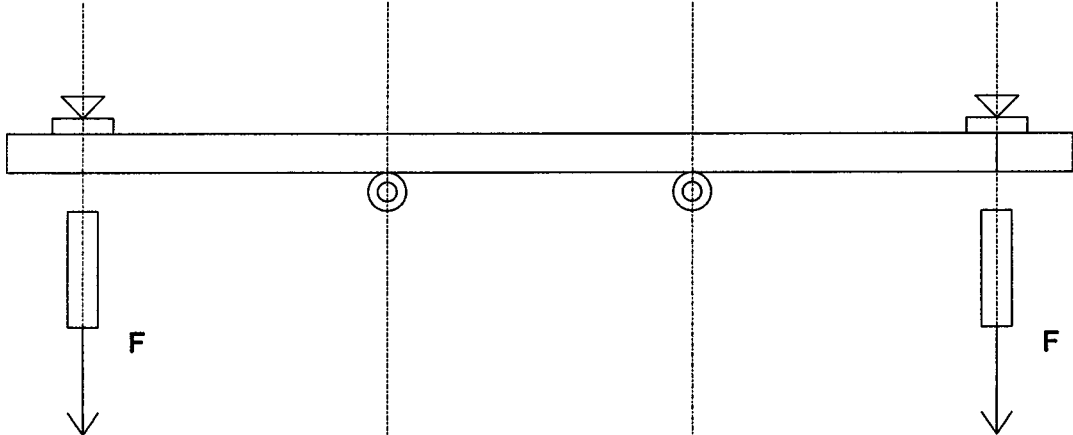

FIG. 2 Calibration Using Four-Point Bending

$$\text{Stress (MPa)} = \text{FORCE (N)} \times \frac{6 L_o(\text{mm})}{w(\text{mm}) l(\text{mm})^2} \quad (2)$$

9.2 Construct a graph as described in 8.3 showing $\tan \theta$ versus stress, when using surface polarimeter, or division versus stress, using critical angle measurement (see Fig. 4).

9.3 Trace “best fit” straight line, to establish the instrument constant K for the surface polarimeter:

$$K = \frac{\Delta \text{Stress}}{\Delta \tan \theta} \quad (3)$$

9.4 Since the relation between the measured distance and the stress in the refractometry is nonlinear, the calibration of this instrument requires an annealed specimen or a specimen exhibiting known surface stress in the unloaded state. For each increment, add the unloaded-specimen stress to the calculated stress and verify calibration of the critical-angle measuring instrument provided by the manufacturer.

10. Report

10.1 Report the following information:

- 10.1.1 Date of calibration.
- 10.1.2 Type and dimension of the specimen.
- 10.1.3 Instrument constant K established (surface polarimeter).
- 10.1.4 Table of data and initial specimen surface stress (critical angle measuring instrument).

11. Precision and Bias

11.1 The precision and bias of this test method will be determined by a round-robin test conducted by Subcommittee C 14.08.⁶

12. Keywords

12.1 calibration; stress measurements; surface stress; tempered glass

⁶ Parties interested in participating in the round-robin test should contact the Committee C-14 manager at ASTM Headquarters.

ASTM C 1377

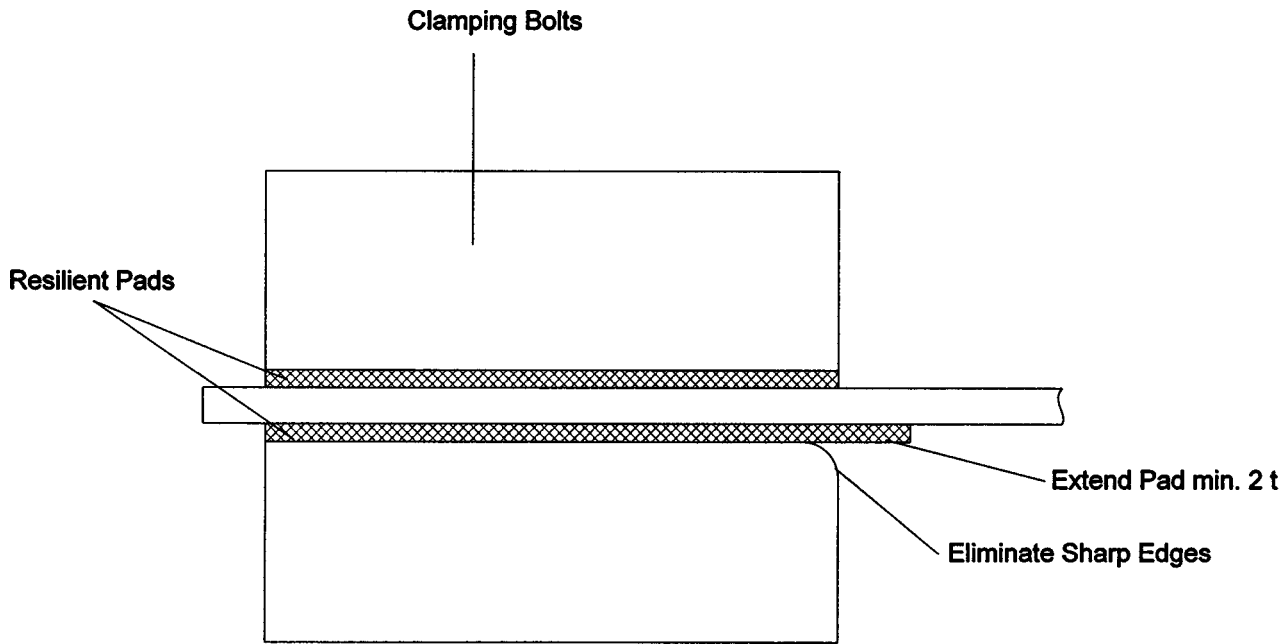

FIG. 3 Clamping of a Cantilever Beam

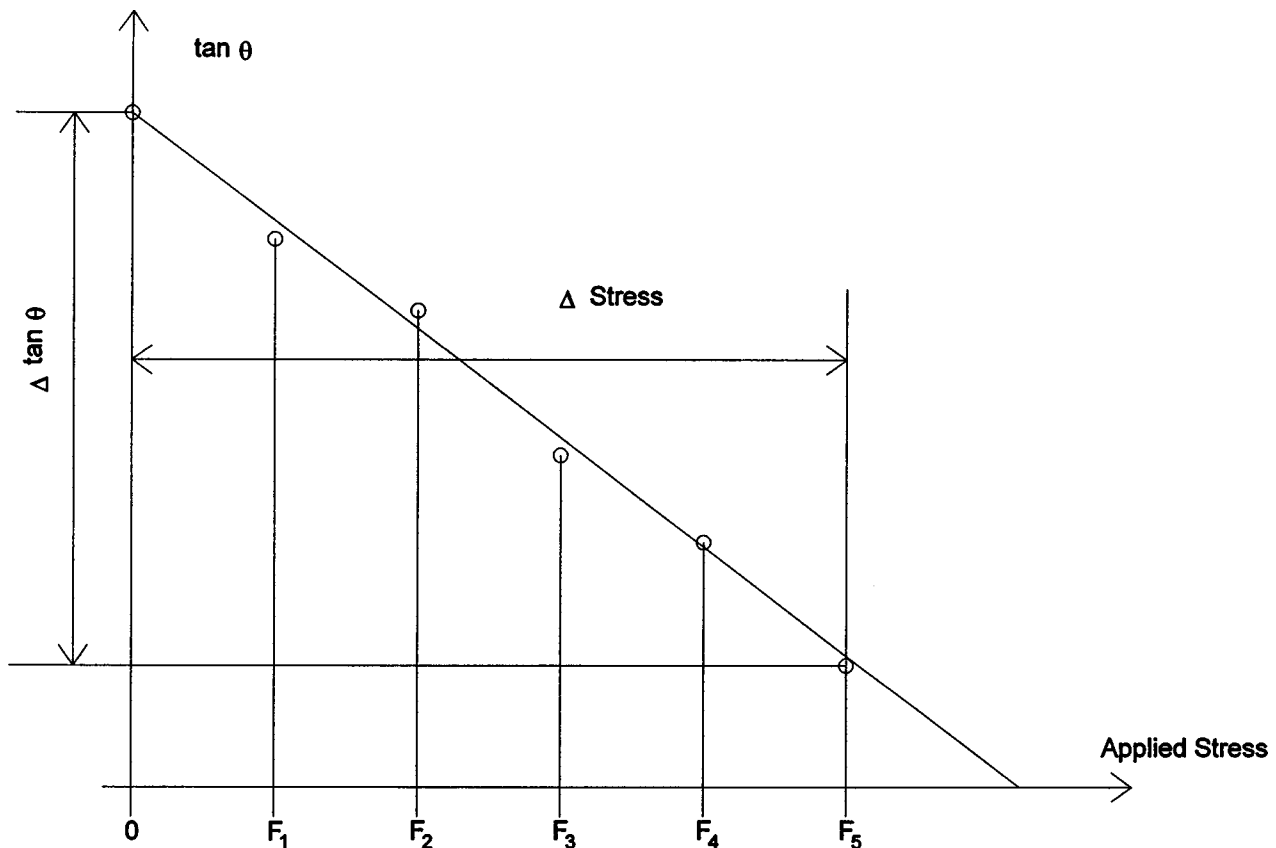

FIG. 4 Graphical Plot of Results

The American Society for Testing and Materials takes no position respecting the validity of any patent rights asserted in connection with any item mentioned in this standard. Users of this standard are expressly advised that determination of the validity of any such patent rights, and the risk of infringement of such rights, are entirely their own responsibility.

This standard is subject to revision at any time by the responsible technical committee and must be reviewed every five years and if not revised, either reapproved or withdrawn. Your comments are invited either for revision of this standard or for additional standards and should be addressed to ASTM Headquarters. Your comments will receive careful consideration at a meeting of the responsible technical committee, which you may attend. If you feel that your comments have not received a fair hearing you should make your views known to the ASTM Committee on Standards, 100 Barr Harbor Drive, West Conshohocken, PA 19428.