



Designation: C 1509 – 012

## Standard Specification for Beaded Process Glass Pipe and Fittings<sup>1</sup>

This standard is issued under the fixed designation C 1509; the number immediately following the designation indicates the year of original adoption or, in the case of revision, the year of last revision. A number in parentheses indicates the year of last reapproval. A superscript epsilon ( $\epsilon$ ) indicates an editorial change since the last revision or reapproval.

### 1. Scope

1.1 This specification covers chemically resistant, low expansion Type-I borosilicate glass, Class A, (see Specification E 438) used to manufacture beaded end flanged-glass pipe and fittings for pressure and vacuum applications.

### 2. Referenced Documents

2.1 *ASTM Standards:*

---

<sup>1</sup> This specification is under the jurisdiction of ASTM Committee C14 on Glass and Glass Products and is the direct responsibility of Subcommittee C14.05 on Glass Pipe. Current edition approved ~~Sept. 10, 2001~~ Apr. 10, 2004. Published ~~November 2001~~ April 2002. Originally published as C 1509 - 01. Last previous edition C 1509 - 01.

- C 162 Terminology of Glass and Glass Products<sup>2</sup>
- C 600 Method of Thermal Shock Test on Glass Pipe<sup>2</sup>
- C 601 Method for Pressure Test on Glass Pipe<sup>2</sup>
- C 623 Test Method for Young’s Modulus, Shear Modulus, and Poisson’s Ratio for Glass and Glass-Ceramics by Resonance<sup>2</sup>
- C 693 Test Method for Density of Glass by Buoyancy<sup>2</sup>
- E 438 Specification for Glasses in Laboratory Apparatus<sup>3</sup>

### 3. Terminology

3.1 For definitions of terms used in this specification, refer to Terminology C 162.

### 4. Materials and Manufacture

4.1 The glass shall be reasonably free of surface defects, such as open blisters or airlines and scratches, and shall be completely free of chips and checks. This is applicable to both the inside and outside surfaces. It shall represent good workmanship as consistent with standard glass process capabilities.

4.2 *Heat Treatment or Annealing*—Pipe and fittings may be suitably heat treated (tempered) or annealed as specified by the manufacturer.

### 5. Chemical Requirements

5.1 The chemical requirements shall be in accordance with Specification E 438.

### 6. Physical Requirements

6.1 The physical requirements shall be as described in Specification E 438.

6.2 Refer also to Annex A1 for additional physical requirements.

### 7. Operating Temperatures

7.1 *Minimum Operating Temperature*—The minimum rated operating temperature for all sizes shall be 0°F (–18°C) provided that the temperature of the material being conveyed is above the freezing point.

7.2 *Maximum Operating Temperature*—The maximum rated operating temperature for all sizes shall be 350°F (177°C).

7.3 *Thermal Shock Resistance*—The maximum allowable sudden temperature differential for properly installed systems shall be in accordance with Table 1 for the various pipe sizes.

7.3.1 Maximum temperature differential refers to an almost instantaneous temperature change, such as low-pressure steam followed directly by a flush of ice cold water, or the reverse. Maximum temperature differential pertains to inside and outside surfaces, exclusive of sign.

7.3.2 The test method for thermal shock is not ordinarily performed, but in those cases where thermal shock resistance may be questioned, it may be performed in accordance with Method C 600. Acceptance of this test shall be that all tested ware shall pass. If one or more failures do occur, a second sampling twice the population of the first, shall be tested. If any failures occur in the second sampling, the entire shipment shall be rejected.

### 8. Pressure Rating

8.1 Maximum recommended working pressure for beaded glass process pipe and fittings shall be in accordance with Table 2, when the pipe is installed in accordance with manufacturer’s recommendations, and when operated within the maximum temperature differential and temperature limit. See 8.3 for vacuum service.

8.2 *Acceptance Pressure Test*—Individual lengths of beaded process pipe or fittings shall withstand an internal hydrostatic pressure test when tested in accordance with Method C 601. Acceptance of this test shall be that all tested ware shall pass. If one or more failures do occur, a second sampling twice the population of the first shall be tested. If any failures occur in the second sampling, the entire shipment shall be rejected.

8.3 All pipe sizes are suitable for vacuum applications.

<sup>2</sup> Annual Book of ASTM Standards, Vol 15.02.

<sup>3</sup> Annual Book of ASTM Standards, Vol 14.04.

**TABLE 1 Maximum Temperature Differential**

Nominal Pipe Size, in.	Sudden Temperature Difference, max, °F (°C)
1 to 2	200 (93)
3	180 (82)
4	140 (60)
6	122 (50)

**TABLE 2 Maximum Working Pressure for Glass Process Pipe and Fittings**

Nominal Pipe Size, in.	Recommended Working Pressure, max, psi (kPa)
1	100 (689)
1½ to 2	75 (517)
3 to 4	50 (345)
6	30 (207)

## 9. Dimensions and Permissible Variations

### 9.1 Beaded Flanges:

9.1.1 *Flange Face Flatness*—Maximum permissible deviation from a flat plane across the face of the flange on all sizes shall be 1/16 in. (1.6 mm).

9.1.2 *Flange Face Squareness*—Flange faces of both pipe and fittings shall be square to the centerline within the limit prescribed in Table 3.

9.1.2.1 Squareness of straight pipe lengths shall be measured by placing the pipe on rollers, located approximately 2 in. (51 mm) from each end, and butting one end against a flat plane perpendicular to the axis of the rollers. The pipe shall be rotated and the length variation read with a suitable mechanism, such as a dial indicator. The maximum variation shall not exceed that shown in Table 3 for several pipe sizes.

9.1.2.2 Pipe fittings shall be measured for flange squareness with a gage having flat plates constructed at the angle required by that fitting. One flange shall be firmly placed on one plate, and the difference between the remaining flange face and the other surface plate shall not exceed the amount shown in Table 3 for the respective fitting size.

9.1.3 *Flange Dimensions and Specifications*—Beaded flange dimensions shall be as required by the manufacturer for the system.

### 9.2 Bow:

9.2.1 *Bow for All Pipe Diameters*—Bow shall be measured by supporting the pipe on “V” blocks, mounted in-line on the same plane, approximately 2 in. from each end of the pipe. A dial gage in contact with pipe at midlength measures variation by rotating the pipe 360°. Bow is defined as half of the measured variation, and shall not exceed 0.25 % of the total length of the pipe.

### 9.3 Dimensions of All Pipe and Fittings (see Annex A1):

9.3.1 *Straight Pipe (Dimensions)*—Dimensional specifications for straight lengths shall be accordance with Table 4.

9.3.2 *Fittings (Dimensions)*—Dimensional specifications for common fittings shall be in accordance with Tables 5-11.

## 10. Inspection

10.1 Inspection of the material shall be made at the point of delivery unless otherwise agreed upon by the purchaser and the seller.

## 11. Packaging

11.1 Pipe, fittings and hardware shall be packaged as to prevent damage to them during transportation and handling. Those items packed in containers conforming to all construction requirements of consolidated freight classification as to bursting tests, size limit, and gross mass shall be considered as being properly packed.

11.2 All hardware shall be packed in such a way as to prevent contact with glass articles.

**TABLE 3 Flange Face Squareness**

Nominal Pipe or Fitting Size, in.	Squareness Measurement max, in.
1 to 2	1/32
3	3/64
4	1/16
6	5/64

TABLE 4 Standard Specifications for Straight Lengths of Pipe

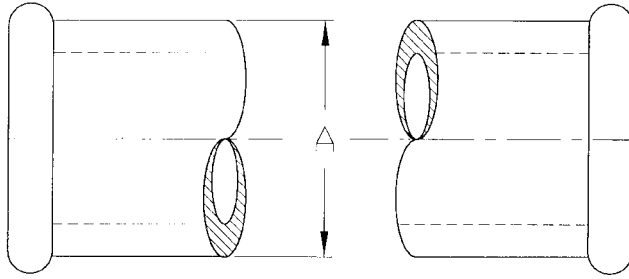

Length  $\pm \frac{1}{8}$  in. (3.2 mm) excluding coupling allowance

Nominal Size, in.	A (Outside Diameter), in. (mm)	
	Dimension	Tolerances
1	$1\frac{5}{16}$ (33.3)	$\pm \frac{3}{64}$ (1.2)
1½	$1\frac{27}{32}$ (46.8)	$\pm \frac{1}{16}$ (1.6)
2	$2\frac{11}{32}$ (59.5)	$\pm \frac{5}{64}$ (2.0)
3	$3\frac{13}{32}$ (86.5)	$\pm \frac{3}{32}$ (2.4)
4	$4\frac{17}{32}$ (115.1)	$\pm \frac{7}{64}$ (2.8)
6	$6\frac{5}{8}$ (168.3)	$\pm \frac{5}{32}$ (4.0)

TABLE 5 Reducer Ells

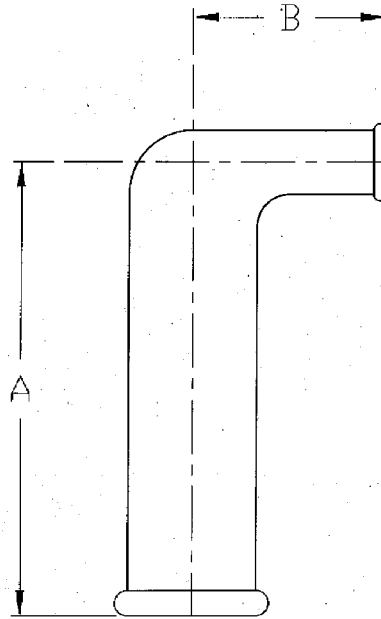

Dimensions<sup>A</sup>

Nominal Size, in.	A, in. (mm) ± 1/8 in. (3.2 mm)	B, in. (mm) ± 1/8 in. (3.2 mm)
1½ by 1	3½ (88.9)	3 (76.2)
2 by 1	4 (101.6)	3 (76.2)
2 by 1½	4 (101.6)	3½ (88.9)
3 by 1	5 (127.0)	3½ (88.9)
3 by 1½	5 (127.0)	4 (101.6)
3 by 2	5 (127.0)	4½ (114.3)
4 by 1	7 (177.8)	4 (101.6)
4 by 1½	7 (177.8)	4½ (114.3)
4 by 2	7 (177.8)	5 (127.0)
4 by 3	7 (177.8)	5½ (139.7)
6 by 1½	9 (228.6)	5½ (139.7)
6 by 2	9 (228.6)	6 (152.4)
6 by 3	9 (228.6)	6½ (165.1)
6 by 4	9 (228.6)	8 (203.2)

<sup>A</sup> Dimensions to beaded flanges include coupling allowance.

TABLE 6 Elbows

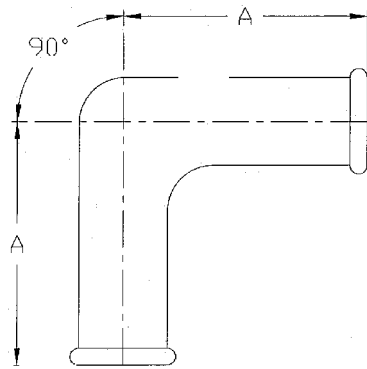
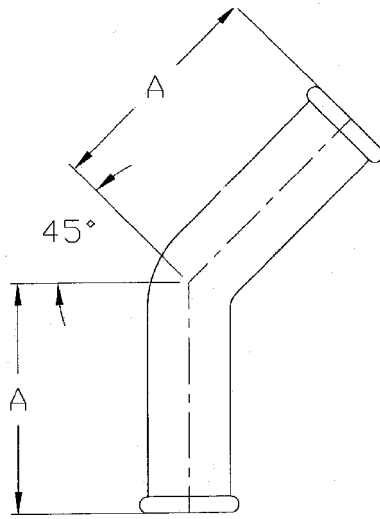

Dimensions<sup>A</sup>

Nominal Size, in.	A, in. (mm) ± 1/8 in. (3.2 mm)
1	2 3/8 (69.9)
1 1/2	3 1/2 (88.9)
2	4 (101.6)
3	5 (127.0)
4	7 (177.8)
6	9 (228.6)

<sup>A</sup> Dimensions to beaded flanges include coupling allowance.

TABLE 7 Sweep Ells

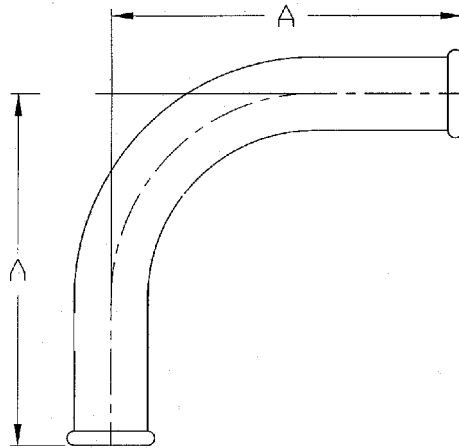

Dimensions<sup>A</sup>

Nominal Size, in.	A, in. (mm) ± 1/8 in. (3.2 mm)
1	4 3/4 (120.7)
1 1/2	5 (127.0)
2	6 (152.4)
3	7 (177.8)
4	10 (254.0)
6	12 (304.8)

<sup>A</sup> Dimensions to beaded flanges include coupling allowance.

TABLE 8 Reducers

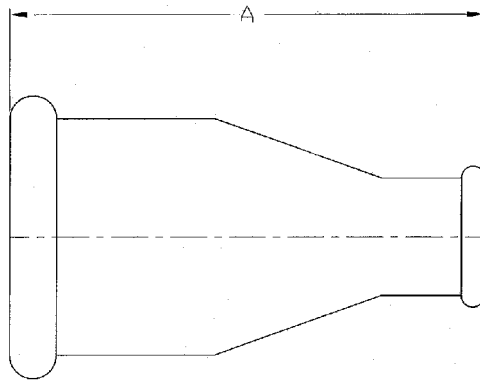

Dimensions<sup>A</sup>

Nominal Size, in.	A, in. (mm) ± 1/8 in. (3.2 mm)	Nominal Size, in.	A, in. (mm) ± 1/8 in. (3.2 mm)
1 1/2 by 1	4 (101.6)	4 by 1 1/2	7 (177.8)
2 by 1	4 (101.6)	4 by 2	7 (177.8)
2 by 1 1/2	4 (101.6)	4 by 3	7 (177.8)
3 by 1	5 (127.0)	6 by 1	9 (228.6)
3 by 1 1/2	5 (127.0)	6 by 1 1/2	9 (228.6)
3 by 2	5 (127.0)	6 by 2	9 (228.6)
4 by 1	7 (177.8)	6 by 3	9 (228.6)
		6 by 4	9 (228.6)

<sup>A</sup> Dimensions to beaded flanges include coupling allowance.

**TABLE 9 Tees**

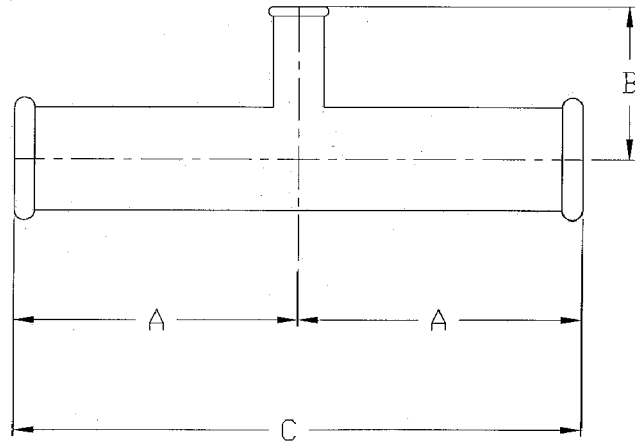

Dimensions<sup>A</sup>

Nominal Size, in.	A, in. (mm) ± 1/8 in. (3.2 mm)	B, in. (mm) ± 1/8 in. (3.2 mm)	C, in. (mm) ± 1/8 in. (3.2 mm)	Nominal Size, in.	A, in. (mm) ± 1/8 in. (3.2 mm)	B, in. (mm) ± 1/8 in. (3.2 mm)	C, in. (mm) ± 1/8 in. (3.2 mm)
1 by 1	2 3/4 (69.9)	2 3/4 (69.9)	5 1/2 (139.7)	4 by 1	7 (177.8)	4 (101.6)	14 (355.6)
1 1/2 by 1	3 1/2 (88.9)	3 (76.2)	7 (177.8)	4 by 1 1/2	7 (177.8)	4 1/2 (114.3)	14 (355.6)
1 1/2 by 1 1/2	3 1/2 (88.9)	3 1/2 (88.9)	7 (177.8)	4 by 2	7 (177.8)	5 (127.0)	14 (355.6)
2 by 1	4 (101.6)	3 (76.2)	8 (203.2)	4 by 3	7 (177.8)	5 1/2 (139.7)	14 (355.6)
2 by 1 1/2	4 (101.6)	3 1/2 (88.9)	8 (203.2)	4 by 4	7 (177.8)	7 (177.8)	14 (355.6)
2 by 2	4 (101.6)	4 (101.6)	8 (203.2)	6 by 1	9 (228.6)	5 (127.0)	18 (457.2)
3 by 1	5 (127.0)	3 1/2 (88.9)	10 (254.0)	6 by 1 1/2	9 (228.6)	5 1/2 (139.7)	18 (457.2)
3 by 1 1/2	5 (127.0)	4 (101.6)	10 (254.0)	6 by 2	9 (228.6)	6 (152.4)	18 (457.2)
3 by 2	5 (127.0)	4 1/2 (114.3)	10 (254.0)	6 by 3	9 (228.6)	6 1/2 (165.1)	18 (457.2)
3 by 3	5 (127.0)	5 (127.0)	10 (254.0)	6 by 4	9 (228.6)	8 (203.2)	18 (457.2)
				6 by 6	9 (228.6)	9 (228.6)	18 (457.2)

<sup>A</sup> Dimensions to beaded flanges include coupling allowance.

TABLE 10 Caps

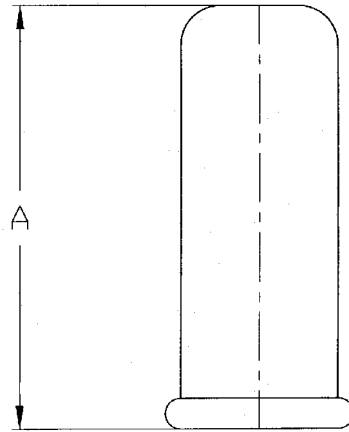

Dimensions<sup>A</sup>

Nominal Size, in.	A, in. (mm) ± 1/8 in. (3.2 mm)
1	2 1/4 (68.3)
1 1/2	3 7/16 (87.3)
2	3 7/8 (98.4)
3	4 11/16 (119.1)
4	5 5/16 (150.8)
6	7 (177.8)

<sup>A</sup> Dimensions to beaded flanges include coupling allowance.

TABLE 11 Crosses

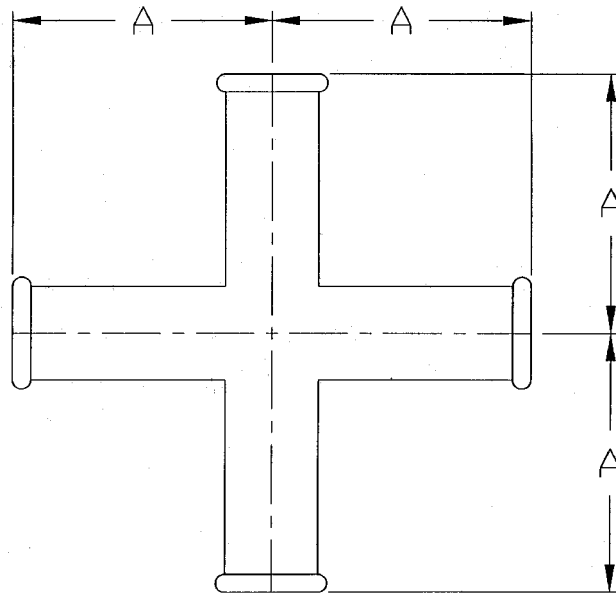

Dimensions<sup>A</sup>

Nominal Size, in.	A, max, in. (mm)
1 by 1	2¾ (69.9)
1½ by 1½	3½ (88.9)
2 by 2	4 (101.6)
3 by 3	5 (127.0)
4 by 4	7 (177.8)
6 by 6	9 (228.6)

<sup>A</sup> Dimensions to beaded flanges include coupling allowance.

## ANNEX

### (Mandatory Information)

#### A1. DIMENSIONS OF ALL PIPE AND FITTINGS

A1.1 *Density*—2.24 g/cm<sup>3</sup>, measured at room temperature by Test Method C 693.

A1.2 *Thermal Conductivity*—0.73 Btu·ft/h·ft<sup>2</sup>·°F (0.0035 cal·cm/s·cm<sup>2</sup>·°C), measured at room temperature.

A1.3 *Specific Heat*—0.20 Btu/lb·°F (0.20 cal/g·°C), measured at 75°C.

A1.4 *Young's Modulus*—9 000 000 to 10 000 000 psi (62 to 69 GPa) when measured at room temperature in accordance with Test Method C 623.

A1.5 *Tensile Strength*—Due to effect of surface conditions on ultimate strength, nominal design shall be 1000 psi (6.9 MPa).

*ASTM International takes no position respecting the validity of any patent rights asserted in connection with any item mentioned in this standard. Users of this standard are expressly advised that determination of the validity of any such patent rights, and the risk of infringement of such rights, are entirely their own responsibility.*

*This standard is subject to revision at any time by the responsible technical committee and must be reviewed every five years and if not revised, either reapproved or withdrawn. Your comments are invited either for revision of this standard or for additional standards and should be addressed to ASTM International Headquarters. Your comments will receive careful consideration at a meeting of the responsible technical committee, which you may attend. If you feel that your comments have not received a fair hearing you should make your views known to the ASTM Committee on Standards, at the address shown below.*

*This standard is copyrighted by ASTM International, 100 Barr Harbor Drive, PO Box C700, West Conshohocken, PA 19428-2959, United States. Individual reprints (single or multiple copies) of this standard may be obtained by contacting ASTM at the above address or at 610-832-9585 (phone), 610-832-9555 (fax), or [service@astm.org](mailto:service@astm.org) (e-mail); or through the ASTM website ([www.astm.org](http://www.astm.org)).*