



Standard Test Method for Annealing Point and Strain Point of Glass by Fiber Elongation¹

This standard is issued under the fixed designation C 336; the number immediately following the designation indicates the year of original adoption or, in the case of revision, the year of last revision. A number in parentheses indicates the year of last reapproval. A superscript epsilon (ϵ) indicates an editorial change since the last revision or reapproval.

This standard has been approved for use by agencies of the Department of Defense.

1. Scope

1.1 This test method covers the determination of the annealing point and the strain point of a glass by measuring the viscous elongation rate of a fiber of the glass under prescribed condition.

1.2 The annealing and strain points shall be obtained by following the specified procedure after calibration of the apparatus using fibers of standard glasses having known annealing and strain points, such as those specified and certified by the National Institute of Standards and Technology (NIST)² (see Appendix X1).

1.3 *This standard does not purport to address all of the safety concerns, if any, associated with its use. It is the responsibility of the user of this standard to establish appropriate safety and health practices and determine the applicability of regulatory limitations prior to use.*

2. Referenced Documents

2.1 ASTM Standards:

C 338 Test Method for Softening Point of Glass³

C 598 Test Method for Annealing Point and Strain Point of Glass by Beam Bending³

3. Definitions

3.1 *annealing point*—that temperature at which internal stresses in a glass are substantially relieved in a matter of minutes.^{4,5,6} During a test in accordance with the requirements of this method, the viscous elongation rate is measured by a

suitable extensometer while the specimen fiber is cooling at a rate of $4 \pm 1^\circ\text{C}/\text{min}$. The elongation rate at the annealing point is approximately 0.14 mm/min for a fiber of 0.65-mm diameter.⁶

3.2 *annealing range*—the range of glass temperature in which stresses in glass articles can be relieved at a commercially desirable rate. For purposes of comparing glasses, the annealing range is assumed to correspond with the temperatures between the annealing point (AP) and the strain point (StP).

3.3 *strain point*—that temperature at which the internal stresses in a glass are substantially relieved in a matter of hours. The strain point is determined by extrapolation of the annealing point data and is the temperature at which the viscous elongation rate is 0.0316 times that observed at the annealing point.

4. Significance and Use

4.1 This test method provides data useful for (1) estimating stress release, (2) the development of proper annealing schedules, and (3) estimating setting points for seals. Accordingly, its usage is widespread throughout manufacturing, research, and development. It can be utilized for specification acceptance.

5. Apparatus

5.1 *Furnace*—The furnace shall be 368-mm (14½-in.) long and approximately 114 mm (4½ in.) in diameter and shall contain a copper core 305 mm (12 in.) long and 29 mm (1⅛ in.) in outside diameter, with inside diameter of 5.6 mm (7/32 in.). It shall be constructed substantially as shown in Fig. 1.

5.1.1 Such a furnace will cool naturally at approximately 4°C (7°F)/min at 500°C (932°F) and at a rate exceeding 3°C (5.5°F)/min at 400°C (752°F).

5.2 *Temperature Measuring and Indicating Instruments*—For the measurement of temperature there shall be provided a thermocouple, preferably platinum-platinum rhodium, inserted in the upper side hole of the copper core, as indicated in Fig. 1, so that its junction is located midway in the length of the core. The thermocouple wire shall not be allowed to directly contact the copper; this can be ensured by placing a 6-mm (¼-in.) length of ceramic tube in the bottom of the hole ahead of the couple. The cold junction of the thermocouple shall be maintained in an ice bath during tests.

¹ This test method is under the jurisdiction of ASTM Committee C-14 on Glass and Glass Products and is the direct responsibility of Subcommittee C14.04 on Physical and Mechanical Properties.

Current edition approved Oct. 25, 1971. Originally published as C 336 – 54 T. Last previous edition C 336 – 69.

² National Institute of Standards and Technology Publication 260.

³ *Annual Book of ASTM Standards*, Vol 15.02.

⁴ Littleton, J. T., and Roberts, E. H., "A Method for Determining the Annealing Temperature of Glass," *Journal of the Optical Society of America*, Vol 4, 1920, p. 224.

⁵ Lillie, H. R., "Viscosity of Glass Between the Strain Point and Melting Temperature," *Journal of American Ceramic Society*, Vol 14, 1931, p. 502; "Re-Evaluation of Glass Viscosities at Annealing and Strain Points," *Journal of American Ceramic Society*, Vol 37, 1954, p. 111.

⁶ McGraw, D. A. and Babcock, C. L., "Effect of Viscosity and Stress Level on Rate of Stress Release in Soda-Lime, Potash-Barium and Borosilicate Glasses," *Journal of the American Ceramic Society*, Vol 42, 1959, p. 330.

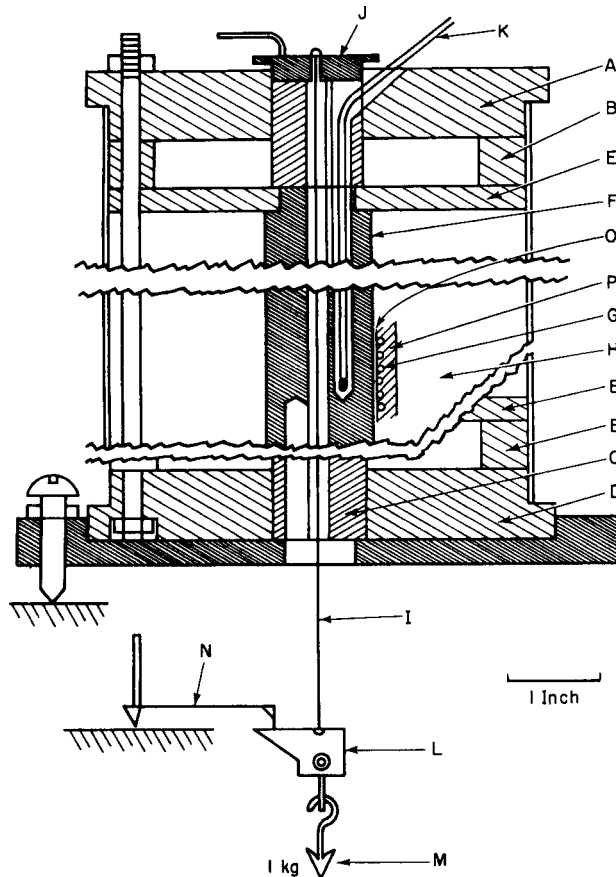

- | | |
|--|---|
| <p>A, B, C, D—Made of asbestos-cement (Transite or equivalent)
 E—Webbed asbestos-cement (Transite or equivalent) disk
 F—Copper core 1 1/8 in. (29 mm) outside diameter by 12 in. (305 mm) total length (Note)
 G—91 turns No. 22 Nichrome V wire (or equivalent)
 H—Diatomaceous earth
 I—Sample fiber
 J—Stainless steel support disk</p> | <p>K—Thermocouple
 L—Lever platform
 M—Load
 N—Optical lever
 O—Wrapping for electrical insulation (mica is suggested)
 P—Refractory cement</p> |
|--|---|

NOTE—A steel alloy, such as Inconel X, may be used as an alternative in place of copper and will allow measurements at higher temperatures.

FIG. 1 Apparatus for Determination of Annealing Point and Strain Point of Glass

5.2.1 The temperature-indicating instrument, preferably a potentiometer, shall be of such quality and sensitivity as to permit reading the thermocouple emf to an amount corresponding to 0.1°C (0.2°F), equivalent to about 1 μV for a platinum couple or to about 4 μV for a base-metal couple.

5.2.2 Provision shall be made for reading temperatures accurately at predetermined moments. One means of accomplishing this is to maintain the potentiometer setting at an electromotive force corresponding to a known temperature, near the annealing point and inferring the temperature from the deflection of a sensitive galvanometer, previously calibrated for the purpose. It is convenient to adjust the galvanometer shunt to a sensitivity of about 3°C (5.5°F)/cm of deflection and to somewhat less than critical damping. This technique for reading temperature changes is one of the preferred methods; in the following sections it will be assumed that this technique has been used, although any other equally sensitive and precise method of following the temperature of the thermocouple may be used.

5.3 Furnace Control—Suitable means shall be provided for idling the furnace, controlling its heating rate, and, in the case

of very hard glasses, limiting the cooling rate to not more than 5°C (9°F)/min. A variable transformer is a convenient device for this purpose. The transformer can also be employed as a switch for interrupting the furnace current.

5.4 Device for Measuring Elongation— The means of observing the rate of elongation of the fiber should be such as to indicate reliably over a range of about 6-mm (1/4-in.) change in fiber length with an uncertainty not greater than about 0.01 mm (0.0004 in.). A convenient method is shown in Fig. 1, where the arm of the optical lever, N, bears upon a platform, L, incorporated in the loading linkage. The fulcrum of the lever should be mounted on a rigid (but height-adjustable) member, substantially free of vibration. With an optical lever arm about 38 mm (1 1/2 in.) long and a scale distance of about 1 m (40 in.), the multiplying factor is about 50. Readings can be made to 0.5 mm on the scale and, if the scale is 508 mm in length, a sufficient range is attained. The scale is curved with its center of curvature at the mirror location. The system may be calibrated by mounting a micrometer screw in place of the platform, L.

5.4.1 Any other extensometer arrangement, such as a linearly variable differential transformer (LVDT) or a travelling microscope, is suitable for measuring elongation, provided that length changes are reliably measured as specified.

5.5 *Micrometer Calipers*, with a least count of 0.005 mm, for measuring specimen fiber diameters.

6. Test Specimen

6.1 *Drawing the Fiber*—Draw a suitable fiber from 2 cm³ (more or less) of glass in any form such as a fragment, cane, flat strip, or tubing. Stick the piece to handles of glass or other suitable material, such as refractory or metal, and then work it into a ball, using a flame adjustment found suitable for the particular kind of glass. When the ball is in a uniform state of proper temperature, and while it is still in the fire, slightly elongate it into a pear shape. Then, remove the ball from the fire, and draw it down to a convenient length.

6.2 *Measurement of Fiber Dimensions*— Measure the fiber with micrometer calipers at 51-mm (2-in.) intervals, and select a 508-mm (20-in.) length that is substantially circular in cross section, has a diameter of 0.65 ± 0.10 mm (0.025 ± 0.004 in.), and is uniform to 0.015 mm (± 0.0006 in.). The fiber used in Method B of this test procedure may be between 102 mm (4 in.) and 203 mm (8 in.) in length; once established, such a short fiber specimen length must be maintained within ± 2 mm for all further calibration and testing.

6.3 *Fiber Preparation*—Prepare the selected length of fiber for the test by melting both its ends down into spherical form about 2.5 mm (0.1 in.) in diameter, taking care that the balls are centered on the fiber axis. Starting 25.4 mm (1 in.) from one end, which is thereafter to be regarded as the top end, remeasure the fiber for diameter at 1 in. intervals over the remaining fiber length or up to a maximum of 305 mm (12 in.). Record the average diameter for subsequent calculations.

7. Calibration with Standard Glass

7.1 *Calibration*—Prepare at least four fibers of the calibrating or standard glass,² with diameters covering the diameter range 0.55 to 0.75 mm. In accordance with procedures in Sections 8 and 9.1, determine the elongation rates at the specified annealing point temperature, and make a calibration plot as in Fig. 2, of the rate of elongation versus the reciprocal square of the fiber diameter. Then use this calibration plot to determine the annealing points of unknown glasses with similar annealing ranges. It is recommended that the apparatus be calibrated periodically depending upon usage.

8. Procedure

8.1 Method A:

8.1.1 *Long Fiber, Furnace Support*—The recommended method of fiber support and loading is as shown in Fig. 1, in which the top of a long fiber is supported on the furnace top itself and the fiber extends entirely through the furnace to the lever platform, *L*, or to the attachment of the load.

8.1.2 *Long Fiber, Independent Support*— An alternative long fiber method is that shown in Fig. 3, in which the top of the fiber is supported independently of the furnace. This method requires the application of a correction for thermal expansion.⁵

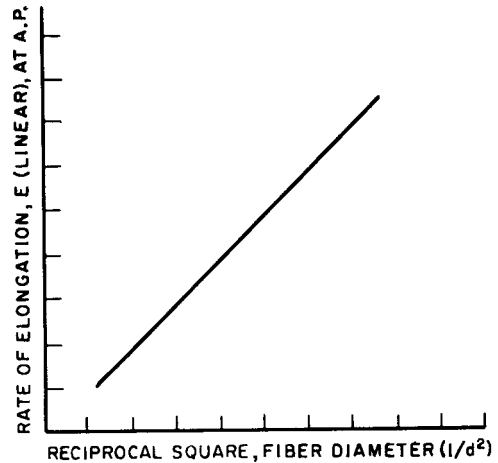

FIG. 2 Calibration

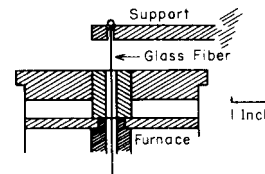

FIG. 3 Apparatus Assembly for Independent Support of Sample Fiber

8.2 Method B:

8.2.1 *Short Fiber, Independent Support*— The short fiber method of support and loading is as shown in Fig. 4, in which the short fiber is supported independently of the furnace between two metal rods. This method requires a larger furnace bore than Method A and application of a correction for thermal expansion.⁵

8.2.2 *Short Fiber, Furnace Support*—In this method the short fiber is joined to the two metal rods as in 7.2.1, except that the upper metal rod is supported by the furnace, being seated in the stainless steel support disk, *J*, in Fig. 1.

8.3 *Assembly of Specimen in Apparatus*— With the furnace at least 25°C (45°F) below the estimated annealing point, insert the bottom end of the sample in the top of the furnace (Note). Put the support disk, *J* (Fig. 1), around the shaft of the sample

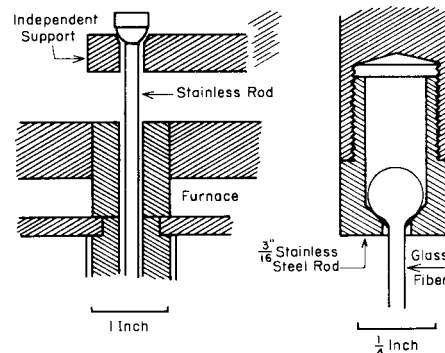

(a) Independent Support for Steel Rod
(b) Method of Attaching Sample Fiber to Steel Rod.
FIG. 4 Apparatus Assembly for Suspension of Sample Fiber Between Metal Rod

and place it in its proper location in the top of the furnace. Lower the sample to seat its upper ball in the support disk. Attach the loading linkage, *L* and *M*, apply a 1-kg load, and bring the optical lever arm to bear on the platform, *L*. Adjust the lever base, *N*, vertically to bring the scale reading near the lower end of the scale.

NOTE 1—**Caution:** Ensure that the bore of the furnace is vertical. Position the fiber so as to be centered as well as possible to avoid contact with the copper core.

8.4 *Heating*—Adjust the position of the extensometer to the lower end of its measuring range. Start heating the furnace at a convenient rate, preferably at about 5°C/min. Stop heating and establish a cooling rate of $4 \pm 1^\circ\text{C}/\text{min}$ when the elongation rate reaches about 0.60 mm/min, or when the furnace temperature is no more than 25°C above the estimated annealing point.

8.5 Immediately after cooling has been established, take readings of both the extensometer and potentiometer alternately at 30-s intervals so that each shall be read at 1-min intervals. Continue readings until the elongation rate is 0.1 mm/min.

9. Calculation

9.1 *Plotting Data*—Take the change in extensometer readings during each 1-min interval as the rate of elongation at the temperature recorded for the middle of that minute. Plot it logarithmically against its corresponding temperature, using standard-form three-cycle graph paper with 85-mm (3⅓-in.) length cycles and linear scale 381 mm (15 in.) long with 300 divisions. The relation should be substantially linear; draw a straight line to represent the plotted points as in Fig. 5, giving more weight to the higher temperature data points.

9.2 *Annealing Point*—Select from the calibration plot in Fig. 2 the elongation rate of the calibrating glass having the same diameter as the test glass. Using the elongation rate thus obtained, select corresponding potentiometer reading from the plot of the glass under measurement. This potentiometer reading indicates the annealing point temperature of the glass under test.

9.3 *Strain Point*—Obtain the strain point by extrapolation of the straight-line plot of Fig. 5. Divide the elongation rate at the annealing point by 31.6 to obtain the elongation rate at the strain point. From the plot in Fig. 5, select the potentiometer reading corresponding to this elongation rate. This potentiometer reading indicates the strain point temperature of the glass under test.

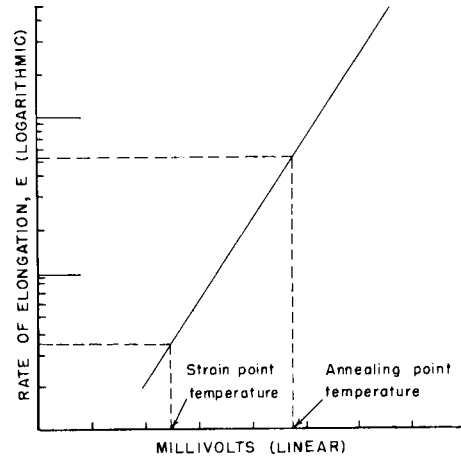

FIG. 5 Calculation

10. Report

- 10.1 Report the following information:
 - 10.1.1 Identification of the glass tested,
 - 10.1.2 Manufacturing source and date,
 - 10.1.3 Calibration reference,
 - 10.1.4 Annealing point,
 - 10.1.5 Strain point, and
 - 10.1.6 Date of test and name of operator.

11. Precision and Bias

11.1 Method A in general will yield annealing points to a standard deviation of $\pm 2^\circ\text{C}$. For higher precision with Method A and for Method B it is necessary to apply a correction for thermal expansion, which must be determined empirically for the apparatus in use by calibrating with NIST standard reference glasses of known thermal expansion and contraction and certified annealing points.⁴ A rigid test of the apparatus is to calibrate with one NIST standard glass and then measure other NIST standard glasses based on this calibration. If the other standard glasses values are within 2°C of certification, excellent performance has been established. If errors arise that increase as the difference in annealing points increases, a temperature measurement or distribution problem may exist. This should be corrected. If attempts to correct such a situation are unsuccessful, an unknown glass should never be measured without calibration with a standard reference glass as close as possible in annealing point.

12. Keywords

- 12.1 annealing point; fiber elongation; glass; strain point

APPENDIX

(Nonmandatory Information)

X1. STANDARD SAMPLES FOR VISCOSITY DETERMINATIONS

X1.1 Standard reference glasses are available as viscosity standards for the calibration and standardization of instruments of the rotating cylinder, fiber elongation, beam-bending, and parallel-plate types. Two of the glasses, Nos. 711 and 717, have been calibrated over the viscosity range from 10^2 to 10^{12} P as well as for the softening, annealing, and strain points. Four glasses, Nos. 712, 713, 715, and 716, have been calibrated only for the softening, annealing, and strain points. Thus, seven

glasses are available for use as standavirds for this test method and Test Methods C 338 and C 598. A certificate listing the certified property values is issued with each sample of standard reference glass.⁷ Samples are available as follows:

⁷ Samples are available from the Standard Reference Materials Program, National Institute of Standards and Technology, Gaithersburg, MD 20899.

SRM Nos.	Name	Unit of Issue
710	Soda-lime silica glass-type 523/586	2 lb (0.90 kg)
711	Lead-silica glass-type 617/366	3 lb (1.36 kg)
712	Mixed alkali lead silicate glass, six ¼-in. patties	0.5 lb (0.22 kg)
713	Dense barium crown 620/603 glass, four 1⅜-in. (35-mm) diameter by ⅝-in. (16-mm) thick gobs	0.5 lb (0.22 kg)
715	Alkali-free aluminosilicate glass, thirteen ¼-in. (6.4-mm) diameter cane, 6-in. (152-mm) long	200 g
716	Neutral (borosilicate) glass, six ½-in. (13-mm) diameter cane, 6 in. (152-mm) long	250 g
717	Borosilicate glass, 42 by 42 by 125-mm bar	500 g

Viscosity (Poises at Indicated Temperature (°C))

SRM Nos.	Viscosity (Poises at Indicated Temperature (°C))											Softening Point, °C	Annealing Point, °C	Strain Point, °C
	10 ²	10 ³	10 ⁴	10 ⁵	10 ⁶	10 ⁷	10 ⁸	10 ⁹	10 ¹⁰	10 ¹¹	10 ¹²			
710a	1464	1205	1037	918	731	545	504
711	1327.1	1072.8	909.0	794.7	710.4	645.6	594.3	552.7	518.2	489.2	464.5	602	432	392
712	528	386	352
713	738	631	599
715	961	764	714
716	794	574	530
717	1545.1	1248.8	1059.4	927.9	831.2	757.1	698.6	651.1	611.9	579.0	550.9	720	516	471

The American Society for Testing and Materials takes no position respecting the validity of any patent rights asserted in connection with any item mentioned in this standard. Users of this standard are expressly advised that determination of the validity of any such patent rights, and the risk of infringement of such rights, are entirely their own responsibility.

This standard is subject to revision at any time by the responsible technical committee and must be reviewed every five years and if not revised, either reapproved or withdrawn. Your comments are invited either for revision of this standard or for additional standards and should be addressed to ASTM Headquarters. Your comments will receive careful consideration at a meeting of the responsible technical committee, which you may attend. If you feel that your comments have not received a fair hearing you should make your views known to the ASTM Committee on Standards, at the address shown below.

This standard is copyrighted by ASTM, 100 Barr Harbor Drive, PO Box C700, West Conshohocken, PA 19428-2959, United States. Individual reprints (single or multiple copies) of this standard may be obtained by contacting ASTM at the above address or at 610-832-9585 (phone), 610-832-9555 (fax), or service@astm.org (e-mail); or through the ASTM website (www.astm.org).