



**Designation: C 601 – 85 (Reapproved 1995)<sup>ε1</sup>**

AMERICAN SOCIETY FOR TESTING AND MATERIALS  
100 Barr Harbor Dr., West Conshohocken, PA 19428  
Reprinted from the Annual Book of ASTM Standards. Copyright ASTM

## **Standard Test Method for Pressure Test on Glass Pipe<sup>1</sup>**

This standard is issued under the fixed designation C 601; the number immediately following the designation indicates the year of original adoption or, in the case of revision, the year of last revision. A number in parentheses indicates the year of last reapproval. A superscript epsilon ( $\epsilon$ ) indicates an editorial change since the last revision or reapproval.

<sup>ε1</sup> NOTE—Section 8 was added editorially in September 1995.

### **1. Scope**

1.1 This test method covers hydrostatic pressure testing of conical end flanged pipe and fittings.

1.2 *This standard does not purport to address all of the safety concerns, if any, associated with its use. It is the responsibility of the user of this standard to establish appropriate safety and health practices and determine the applicability of regulatory limitations prior to use.*

### **2. Significance and Use**

2.1 This test method provides a practical means to assess the strength of glass pipe under internal positive hydrostatic pressure. Since test pressures are twice-rated values, the test represents a stringent evaluation of product strength.

### **3. Apparatus**

3.1 The apparatus, as illustrated in Fig. 1, shall be capable of the following:

3.1.1 So designed that it can produce a regulated loading rate of 3 psi (21 kPa)/s.

3.1.2 So designed that it can produce hydrostatic pressure up to 500 psi (3.4 MPa).

3.1.3 Pipe-end seals and connections to testing apparatus shall be made as shown in Fig. 2.

### **4. Sampling**

4.1 A random sampling of ½ to 1 % (but not less than two pieces) of each size of pipe and fittings shall be made.

<sup>1</sup> This test method is under the jurisdiction of ASTM Committee C-14 on Glass and Glass Products and is the direct responsibility of Subcommittee C14.05 on Glass Pipe.

Current edition approved July 26, 1985. Published October 1985. Originally published as C 601 – 67 T. Last previous edition C 601 – 70 (1984).

### **5. Procedure**

5.1 Cap the pipe as illustrated in Fig. 2, using standard fittings and inserts with blind flanges as end caps. Specify the bolt torque.

5.2 Fill the pipe entirely with liquid, with no entrapped air, and place behind a protective shield. Keep both pipe and liquid at room temperature before testing. Use a torsion wrench to tighten nuts in stages uniformly all around the flange to bolt torque shown in Table 1.

5.3 Fittings, and pipe up to 2 ft (610 mm) in length, may be tested in the horizontal position with the flanges resting on the test table or surface. When testing pipe more than 2 ft in length, suspend it with straps located 12 in. (305 mm) from each flange connection.

5.4 *Pass Test*—Apply the internal pressure at a loading rate of 3 psi (21 kPa)/s, and hold at the test pressure level specified in Table 1 for a period not less than 3 min, or more than 5 min.

### **6. Report**

6.1 Report the following:

6.1.1 Sampling percentage,

6.1.2 Number, size, and description of each sample tested,

6.1.3 Loading rate, maximum pressure attained, and duration at maximum level, and

6.1.4 Results of test.

### **7. Precision and Bias**

7.1 Due to the fail-pass nature of the test, statements on precision and bias are not applicable.

### **8. Keywords**

8.1 glass; pipe; pressure

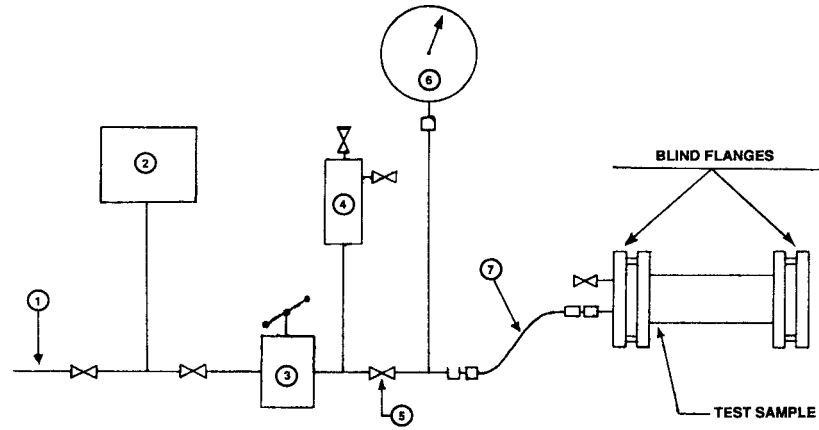

- 1—Main water supply.
- 2—Reservoir.
- 3—Pump, Henderer, or equivalent, hand pump, 3/4-in. (19-mm) piston.
- 4—Pressure surge chamber, 2 by 12-in. (51 by 305-mm) galvanized pipe.
- 5—Limiting orifice, 1/4-in. (6.4-mm) bronze steam gage cock with 1/8-in. (3.2-mm) diameter port.
- 6—Pressure gage, for low pressures, 0 to 100 psig (689 kPa); for medium pressures 0 to 500 psi (3.2 MPa).
- 7—Flexible pressure hose, hydraulic-type pressure hose with 1/4-in. (6.4-mm) pipe connections 18 to 24 in. (457 to 610 mm) long.

FIG. 1 Glass Pipe Standard Pressure Test

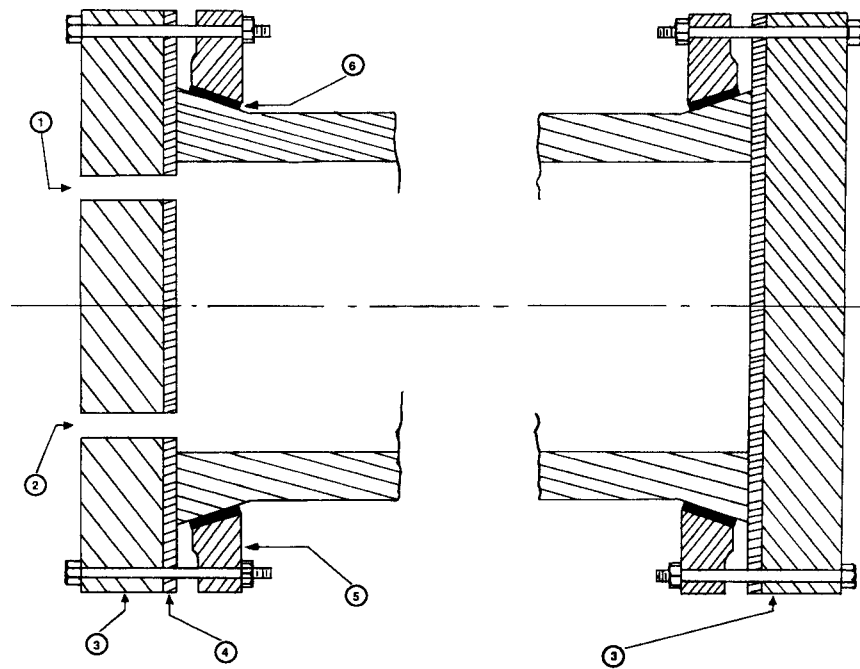

- 1—For vent, 1/8-in. (3.2-mm) male-female stop cock.
- 2—Inlet, 1/4-in. (6.4-mm) tubing, 1/8-in. (3.2-mm) pipe thread, compression fitting.
- 3—150-psi (1-MPa) ANSI blind flange.
- 4—Standard gasket.
- 5—Standard flange connection.
- 6—Standard insert.

FIG. 2 Glass Process Pipe Standard Pressure Test

**TABLE 1 Specifications for Bolting Torque and Test Pressure**

Nominal Pipe Size, in.	Bolting Torque Regular Gasket, lbf-ft (N·m)	Bolting Torque Solid TFE-Fluorocarbon lbf-ft (N·m)	Max Recommended Pressure, psi (kPa)	Test Pressure, psi (kPa)
¼ to ½	2 (271)	2 (271)	100 (689)	200 (1379)
¾	2 (271)	2 (271)	75 (517)	150 (1034)
1	2 (271)	2 to 3 (271 to 407)	50 (345)	100 (689)
1½	3 to 3.5 (407 to 474)	3 to 4 (407 to 542)	50 (345)	100 (689)
2	3 to 4 (407 to 542)	4 to 5 (542 to 678)	50 (345)	100 (689)
3	3 to 4 (407 to 542)	4 to 5 (542 to 678)	50 (345)	100 (689)
4	3 to 4 (407 to 542)	5 to 7 (678 to 949)	35 (241)	70 (483)
6	5 to 6 (678 to 813)	7 to 10 (949 to 1355)	20 (138)	40 (276)

*The American Society for Testing and Materials takes no position respecting the validity of any patent rights asserted in connection with any item mentioned in this standard. Users of this standard are expressly advised that determination of the validity of any such patent rights, and the risk of infringement of such rights, are entirely their own responsibility.*

*This standard is subject to revision at any time by the responsible technical committee and must be reviewed every five years and if not revised, either reapproved or withdrawn. Your comments are invited either for revision of this standard or for additional standards and should be addressed to ASTM Headquarters. Your comments will receive careful consideration at a meeting of the responsible technical committee, which you may attend. If you feel that your comments have not received a fair hearing you should make your views known to the ASTM Committee on Standards, 100 Barr Harbor Drive, West Conshohocken, PA 19428.*