



Designation: C 657 – 93 (Reapproved 1998)

## Standard Test Method for D-C Volume Resistivity of Glass<sup>1</sup>

This standard is issued under the fixed designation C 657; the number immediately following the designation indicates the year of original adoption or, in the case of revision, the year of last revision. A number in parentheses indicates the year of last reapproval. A superscript epsilon ( $\epsilon$ ) indicates an editorial change since the last revision or reapproval.

### 1. Scope

1.1 This test method covers the determination of the dc volume resistivity of a smooth, preferably polished, glass by measuring the resistance to passage of a small amount of direct current through the glass at a voltage high enough to assure adequate sensitivity. This current must be measured under steady-state conditions that is neither a charging current nor a space-charge, buildup polarization current.

1.2 This test method is intended for the determination of resistivities less than  $10^{16}$   $\Omega$ -cm in the temperature range from 25°C to the annealing point of the glass.

1.3 *This standard does not purport to address all of the safety concerns, if any, associated with its use. It is the responsibility of the user of this standard to establish appropriate safety and health practices and determine the applicability of regulatory limitations prior to use.* For specific hazard statements, see Section 5.

### 2. Referenced Documents

#### 2.1 ASTM Standards:

D 257 Test Methods for DC Resistance or Conductance of Insulating Materials<sup>2</sup>

D 374 Test Methods for Thickness of Solid Electrical Insulation<sup>2</sup>

D 1711 Terminology Relating to Electrical Insulation<sup>2</sup>

D 1829 Test Method for Electrical Resistance of Ceramic Materials at Elevated Temperatures<sup>2</sup>

### 3. Summary of Test Method

3.1 The dc volume resistance is measured in accordance with Test Methods D 257, with the specimen located in a heating chamber with adequate temperature control, electrical shielding and insulation of the sample leads as described in Test Method D 1829.

### 4. Significance and Use

4.1 This experimental procedure yields meaningful data for the dc volume resistivity of glass. It is designed to minimize

space charge, buildup polarization effects, and surface conductances. The temperature range is limited to room temperature to the annealing point of the specimen glass.

### 5. Cautions

5.1 Thermal emfs should be avoided. Connections involving dissimilar metals can cause measurement difficulties. Even copper-copper oxide junctions can produce high thermal emfs. Clean, similar metals should be used for electrical junctions. Platinum is recommended. Welded or crimped connections rather than soldered joints avoid difficulties. Specimen electrodes shall have sufficient cross section for adequate electrical conductance.

### 6. Apparatus

6.1 *Resistance-Measuring Devices*, and the possible problems associated with them are discussed thoroughly in Section 9 and Appendixes A1 and A3 of Test Methods D 257. Further discussion of electrometer circuitry is covered in Annex A1 to this test method.

6.2 *Heating Chamber (Fig. 1)*—For heating the specimen, a suitable electric furnace shall be used. The construction of the furnace shall be such that the specimen is subjected to a uniform heat application with a minimum of temperature fluctuation. An adequate muffle should be provided to shield the specimen from direct radiation by the heating elements. This may be made of a ceramic such as aluminum oxide or equivalent. A grounded metallic shield shall also be provided within the furnace, preferably of silver, stainless steel, or equivalent, to isolate electrically the specimen test circuit from the heating element. Furnaces for more than one specimen can be constructed. The control thermocouple may be located in the heating chamber outside the metallic shield, as shown in Fig. 1, or inside the metallic shield.

6.3 *Two Flat Contacting Electrodes*, smaller in diameter than the specimen electrodes (see 7.6), shall be used to sandwich the specimen. Sufficient thickness should be used to maintain an adequate pressure and to provide heat equalization between the specimen and the contacting electrodes.

6.3.1 Fig. 2 shows the specimen setup in the heating chamber. The bottom electrode shall be placed at the end of a metal rod and shall support the specimen in the center of the furnace. The unguarded specimen electrode, No. 3 of Fig. 3,

<sup>1</sup> This test method is under the jurisdiction of ASTM Committee C-14 on Glass and Glass Products and is the direct responsibility of Subcommittee C14.04 on Physical and Mechanical Properties.

Current edition approved May 15, 1993. Published July 1993. Originally published as C 657 – 70 T. Last previous edition C 657 – 88.

<sup>2</sup> *Annual Book of ASTM Standards*, Vol 10.01.

**ASTM C 657 - 93 (1998)**

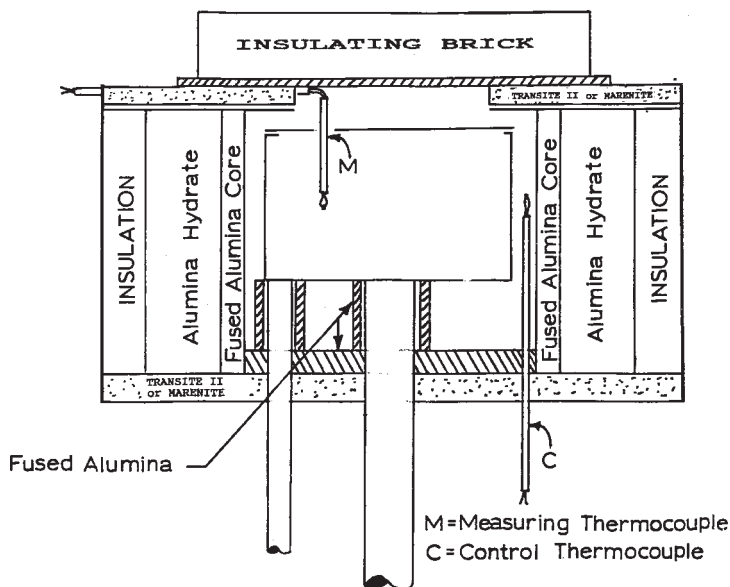

NOTE 1—Heating elements attached to fused alumina core—covered with baked-on refractory cement.

**FIG. 1 Heating Chamber**

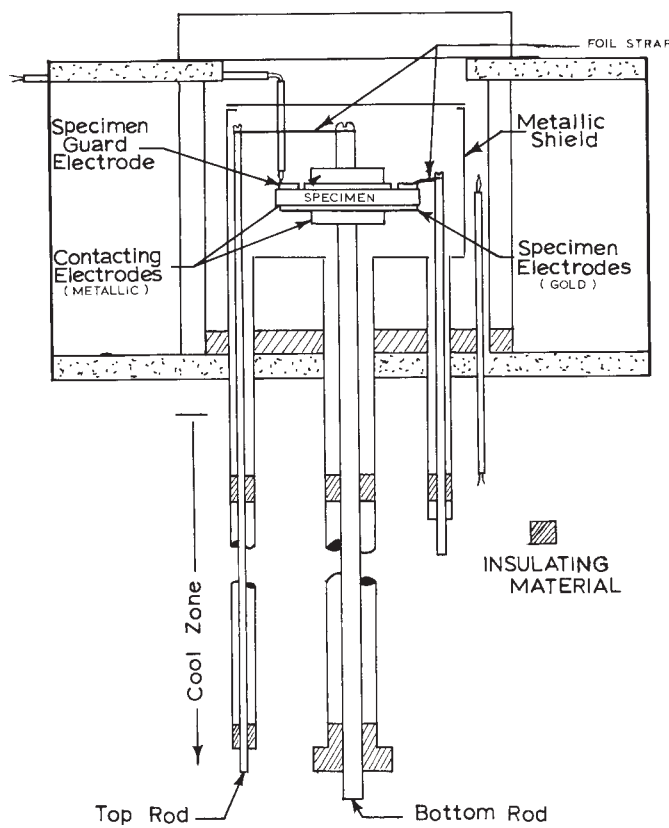
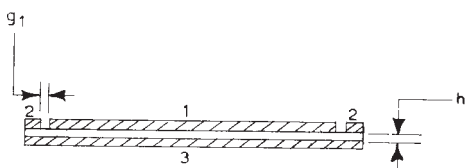
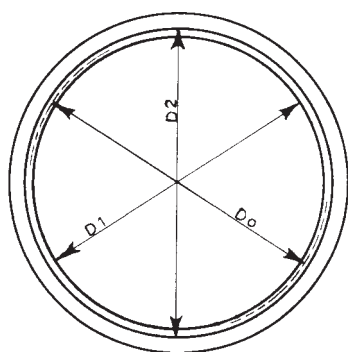

**FIG. 2 Specimen Setup for Heating Chamber**

shall be placed in contact with this bottom contacting electrode. The top contacting electrode shall be placed on the guarded, specimen electrode, No. 1 of Fig. 3. This top contacting electrode has leads connected to an off-center metal rod. The specimen guard electrode, No. 2 of Fig. 3, shall be connected to the second off-center metal rod with platinum

wire or strap. One end shall be connected to the specimen guard electrode; the other end shall be connected to the metal rod.

6.3.2 All rods should be supported by insulation outside the furnace in a cool zone to minimize electrical leakage at elevated temperatures.



**FIG. 3 Glass Specimen with Three-Terminal Electrodes**

6.3.3 Fig. 4 shows a top view of the specimen setup in the heating chamber.

6.4 A *Temperature-Control System* should be provided so that temperature-time fluctuations within the heating chamber are less than  $0.01 T$  (where  $T$  is the temperature in degrees Celsius), during the time interval when resistance measurements are made. Two thermocouples should be used for accurate temperature readings, one in the heating chamber, supplying the emf to the temperature controller and the other on the guard ring of the specimen. The latter should be used to measure the specimen temperature as instructed in the Apparatus section (*Temperature-Control Device*) of Test Method D 1829.

## 7. Test Specimen

7.1 The Test Specimens section (*Volume Resistance or Conductance Determination*) of Test Methods D 257 describes

in detail the specimen requirements. To quote in part, "The test specimen may have any practical form that allows the use of a third electrode, when necessary, to guard against error from surface effects." For practical reasons, a flat disk or square that is easy to set up in a furnace box is recommended. Other configurations are possible. The descriptions will apply to flat samples but can be modified for other configurations. Recommended limitations in the diameter of a disk are 40 to 130 mm. This is not a critical dimension as the effective area of measurements is defined by the area of the applied electrodes, as stated in 7.7.

7.2 As the electrical properties of glass are dependent on the thermal condition of the specimen, this condition should be known and reported.

NOTE 1—The glass could be annealed or have had a special heat treatment which should be clearly defined.

7.3 Polished surfaces are preferable as they permit easier cleaning and application of metallic electrodes.

7.4 Thickness of the specimen should be determined with micrometer calipers, calibrated to 0.01 mm, averaging several measurements on the specimen, as described in Test Methods D 374. Recommended limitations on thickness are from 1.0 to 4.0 mm with a maximum variation of  $\pm 0.1$  mm.

7.5 There are two main reasons for cleaning a specimen: (1) to assure better contact between an applied electrode and the surface of the specimen and (2) to remove contaminants that may lower the surface resistivity, thereby introducing an error in the measurements. If the glass is chemically durable, a recommended cleaning procedure is: (1) trichloroethylene, (2) detergent-water solution, (3) distilled water rinse, and (4) alcohol rinse, air dry. Special surface treatments, poor durability, or the desire to include the effect of surface treatment require modification or elimination of the cleaning procedure.

7.6 *Specimen Electrodes*, preferably of gold (vacuum-evaporated), should be applied to clean surfaces in a three-terminal configuration (Fig. 3). These electrodes should have a low resistance ( $<5 \Omega$  across the guarded electrode). Silver ions

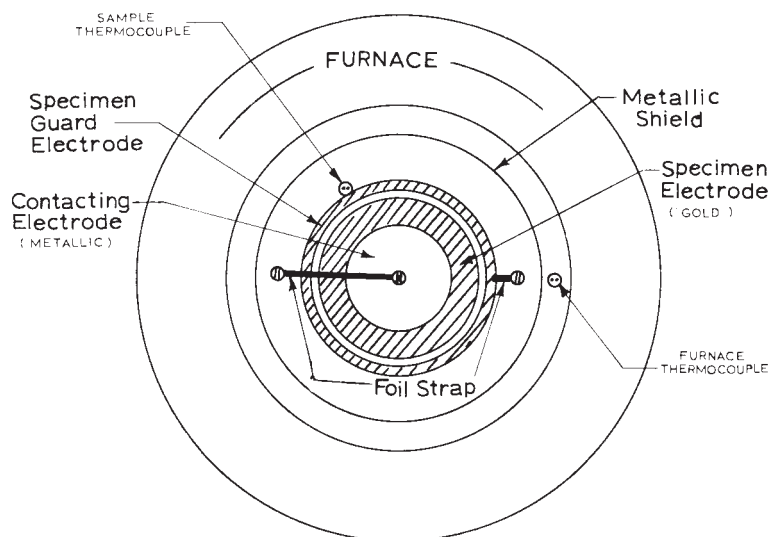

**FIG. 4 Specimen Setup for Heating Chamber**

can migrate into a glassy network at elevated temperatures. Because of this, silver is not a preferred electrode material for glass.

7.7 In Fig. 3, the following relationships should be followed:

$$D_0 = (D_1 + D_2)/2, D_1 \geq 20h, g_1 \leq h \quad (1)$$

Recommended limits for  $D_0$  are 22.0 to 90.0 mm, with the maximum variation of  $\pm 0.50$  mm.  $g_1$  shall be as narrow as possible or less than 2.00 mm.  $h$  shall be 1 to 4 mm. These limits are important to avoid fringing errors. See Appendix A2 of Test Methods D 257 for a more precise calculation of the effective area of guarded electrode.

7.8 The ratio of the effective diameter of the specimen,  $D_0$ , to the specimen thickness,  $h$ , should be high enough to assure a measurable range of resistance.

## 8. Procedure

8.1 Before electrical measurement, prepare the specimen as follows:

8.1.1 Measure the thickness (7.4).

8.1.2 Clean (7.5).

8.1.3 Apply the electrodes (7.6).

8.1.4 Determine the effective area of the guarded specimen electrode (9.1).

8.2 Measure the dc volume resistance at stabilized temperatures and in an increasing temperature sequence. The thermocouple on the specimen is the determining one for stabilization. The furnace thermocouple may reach equilibrium before the specimen thermocouple and the two may differ by several degrees. Stabilization of specimen thermocouple, rather than an agreement between thermocouples, is required.

8.3 At temperature equilibrium, apply to the unguarded electrode a voltage sufficient in magnitude to give adequate sensitivity. Connect the measuring instrument between the guarded electrode and ground. Apply the voltage for that period of time required to obtain a steady-state reading. This is described in A1.3 of Test Methods D 257. The voltage should be removed from the specimen until the next stabilized temperature is reached. The time of electrification should be noted at each temperature.

NOTE 2—As discussed in the Annex A1 of this test method, to ascertain that surface resistance is not shunting the input resistance of the measuring instrument, the resistance between the guard electrode and the guarded electrode should be measured. This value should be 10 to 100 times greater than the input resistance of the meter.

8.3.1 *At Low Temperatures* (high resistivities  $> 10^{13} \Omega\text{-cm}$ ), this time of electrification may be minutes. If the time becomes too long (arbitrarily 30 min), it is advisable to raise the temperature  $50^\circ\text{C}$  or more to assure an accurate measurement. This avoids the possibility of measuring a charging current that is greater than the steady-state current.

8.3.2 *At Intermediate Temperatures*, where the dc volume resistivities are usually between  $10^9$  and  $10^{13} \Omega\text{-cm}$ , the time required for obtaining the dc resistance of glass is reasonable. This is the temperature range in which reliable data can be most easily obtained. The charging time is short, a steady-state current is readily reached, and the possibility of seeing a space-charge buildup of the interfacial polarization is remote.

8.3.3 *At High Temperatures* (low resistivities  $< 10^9 \Omega\text{-cm}$ ), the time of electrification is short. The steady-state reading is reached quickly. However, an increase in resistance is seen with time because of the space-charge buildup of the interfacial polarization. This will result in erroneous data. At these temperatures, the dc volume resistance may only be obtained with an ac signal. If low-frequency facilities are not available, it is better to lower the temperature range of the dc measurements.

8.4 The volume resistance should be obtained at a minimum of four temperatures. For most glasses, these data will lie on a straight line when the log of the resistance or resistivity is plotted versus the reciprocal of the absolute temperature. If the data do not fall in a straight line, more data at closer temperature intervals will be needed to determine that portion of the curve which is a straight line. It is only in this straight-line portion of the curve that reliable dc resistivity data can be obtained with a dc potential.

8.5 The curve in Fig. 5 illustrates the three temperature ranges discussed. In the low-temperature range,  $T_1$ , insufficient time has been allowed to reach a steady-state condition. This period of time cannot only be impractical, but impossible, if the limit of the measuring instrument is exceeded. In the high-temperature range,  $T_3$ , the steady-state condition is reached too rapidly to be seen with a dc potential. Therefore, the temperature range labeled  $T_2$  is the only range in which reliable dc volume resistivity data can be obtained. Any exceptions to this curve are best ascertained by the use of low-frequency measurements.

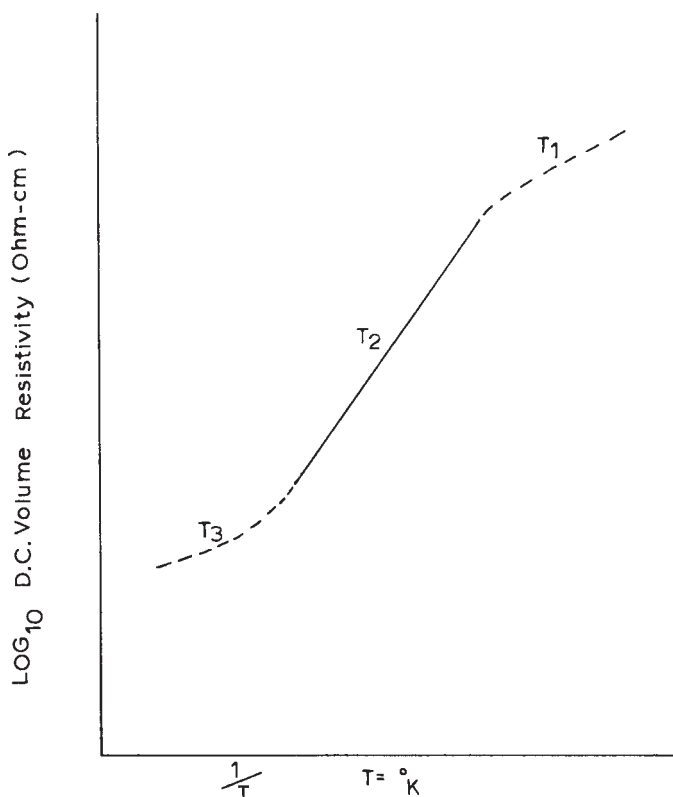

FIG. 5 Model Curve of dc Volume Resistivity Versus Temperature

## 9. Calculations

9.1 Calculate the resistivity of the specimen at each observed temperature as follows:

$$\rho = R \times (A/h) \quad (2)$$

where:

$\rho$  = dc volume resistivity,  $\Omega$ -cm;

$R$  = dc volume resistance,  $\Omega$ ;

$A$  = effective area,<sup>3</sup>  $\text{cm}^2 = \pi D_0^2/4$ ; and

$h$  = effective thickness, cm.

9.2 As stated in 8.1, plot the log of the dc volume resistivity against the reciprocal of the absolute temperature.

9.3 Extrapolation of data to higher or lower temperatures may be misleading.

## 10. Report

10.1 Report the following information:

10.1.1 Identification of the glass tested,

- 10.1.2 Thermal condition of the specimen,
- 10.1.3 Description of cleaning procedure, if other than standard,
- 10.1.4 Manufacturing source and data,
- 10.1.5 Accuracy of the resistance measurements,
- 10.1.6 Accuracy of the temperature measurements,
- 10.1.7 Method used, and
- 10.1.8 Plot of these data (8.2).

## 11. Precision and Bias

11.1 *Precision*—The precision of this test method is approximately  $\pm 5\%$ .

11.2 *Bias*—Bias can be assessed through experimental determinations using NIST SRM 624.<sup>4</sup>

<sup>3</sup> For further refinement of calculation see Appendix X2 (Effective Area of Guarded Electrode) of Test Methods D 257.

<sup>4</sup> Available from the Office of Standard Reference Materials, U.S. Department of Commerce, National Institute of Standards and Technology, Room B311, Chemistry Building, Gaithersburg, MD 20899.

## ANNEX

### (Mandatory Information)

#### A1. FACTORS AFFECTING RESISTANCE MEASUREMENTS

A1.1 In Appendix X1.9 (Guarding) of Test Methods D 257 it is emphasized that errors in current measurements may result if the electrometer is shunted by the resistance between the guarded electrode and the guard system. This shunt resistance should be at least 10 to 100 times the input resistance of the electrometer. In general, electrometers have input resistances

that vary between  $10^6$  and  $10^{13}$ . The resistance between the guarded and guard electrodes may vary between  $10^4$  and  $10^{14}$ . Thus, it is important to know this shunt resistance. This resistance can be measured by connecting the battery to the guard electrode and the electrometer to the guarded electrode. The other electrode is connected to ground.

*ASTM International takes no position respecting the validity of any patent rights asserted in connection with any item mentioned in this standard. Users of this standard are expressly advised that determination of the validity of any such patent rights, and the risk of infringement of such rights, are entirely their own responsibility.*

*This standard is subject to revision at any time by the responsible technical committee and must be reviewed every five years and if not revised, either reapproved or withdrawn. Your comments are invited either for revision of this standard or for additional standards and should be addressed to ASTM International Headquarters. Your comments will receive careful consideration at a meeting of the responsible technical committee, which you may attend. If you feel that your comments have not received a fair hearing you should make your views known to the ASTM Committee on Standards, at the address shown below.*

*This standard is copyrighted by ASTM International, 100 Barr Harbor Drive, PO Box C700, West Conshohocken, PA 19428-2959, United States. Individual reprints (single or multiple copies) of this standard may be obtained by contacting ASTM at the above address or at 610-832-9585 (phone), 610-832-9555 (fax), or service@astm.org (e-mail); or through the ASTM website (www.astm.org).*