



Designation: C 829 – 81 (Reapproved 1995)^{ε1}

AMERICAN SOCIETY FOR TESTING AND MATERIALS
100 Barr Harbor Dr., West Conshohocken, PA 19428
Reprinted from the Annual Book of ASTM Standards. Copyright ASTM

Standard Practices for Measurement of Liquidus Temperature of Glass by the Gradient Furnace Method¹

This standard is issued under the fixed designation C 829; the number immediately following the designation indicates the year of original adoption or, in the case of revision, the year of last revision. A number in parentheses indicates the year of last reapproval. A superscript epsilon (ϵ) indicates an editorial change since the last revision or reapproval.

^{ε1} NOTE—Section 10 was added editorially in April 1995.

1. Scope

1.1 These practices cover procedures for determining the liquidus temperature (Note 1) of a glass (Note 1) by establishing the boundary temperature for the first crystalline compound, when the glass specimen is held at a specified temperature gradient over its entire length for a period of time necessary to obtain thermal equilibrium between the crystalline and glassy phases.

NOTE 1—These terms are defined in Definitions C 162.

1.2 Two methods are included, differing in the type of sample, apparatus, procedure for positioning the sample, and measurement of temperature gradient in the furnace. Both methods have comparable precision. Method B is preferred for very fluid glasses because it minimizes thermal and mechanical mixing effects.

1.2.1 *Method A* employs a trough-type platinum container (tray) in which finely screened glass particles are fused into a thin lath configuration defined by the trough.

1.2.2 *Method B* employs a perforated platinum tray on which larger screened particles are positioned one per hole on the plate and are therefore melted separately from each other.²

1.3 *This standard does not purport to address all of the safety concerns, if any, associated with its use. It is the responsibility of the user of this standard to establish appropriate safety and health practices and determine the applicability of regulatory limitations prior to use.*

2. Referenced Documents

2.1 ASTM Standards:

C 162 Terminology of Glass and Glass Products³

E 220 Method for Calibration of Thermocouples by Comparison Techniques⁴

¹ These practices are under the jurisdiction of ASTM Committee C-14 on Glass and Glass Products and are the direct responsibility of Subcommittee C14.04 on Physical and Mechanical Properties.

Current edition approved Dec. 28, 1981. Published March 1982. Originally published as C 829-76. Last previous edition C 829-76.

² From *NBS Research Paper RP2096*, Vol 44, May 1950, by O. H. Grauer and E. H. Hamilton, with modification and improvement by K. J. Gajewski, Ford Motor Co., Glass Research and Development Office (work unpublished).

³ *Annual Book of ASTM Standards*, Vol 15.02.

⁴ *Annual Book of ASTM Standards*, Vol 14.03.

2.2 Other Document:

NIST Certificate for Liquidus Temperature, SRM 773⁵

3. Significance and Use

3.1 These practices are useful for determining the maximum temperature at which crystallization will form in a glass, and a minimum temperature at which a glass can be held, for extended periods of time, without crystal formation and growth.

4. Apparatus

4.1 The apparatus for determining the liquidus temperature shall consist essentially of an electrically heated gradient furnace, a device for controlling the furnace temperature, temperature measuring equipment, and other items listed.

4.1.1 Furnace:

4.1.1.1 *Method A*—Horizontal temperature gradient, electrically heated furnace, tube type, as illustrated in Fig. 1, Fig. 2, and Fig. 3 and described in A1.1.

4.1.1.2 *Method B*—An alternative furnace detail employing pregrooved Al₂O₃ cores and dual windings, as illustrated in Fig. 4 and Fig. 5, and described in A1.2.

4.1.1.3 Equivalent temperature gradient conditions may also be obtained with furnaces having multiple windings equipped with separate power and control, or a tapped winding shunted with suitable resistances. *For high precision, temperature gradients in excess of 10°C/cm should be avoided.*

4.1.2 Furnace Temperature Control:

4.1.2.1 *Method A*—A suitable temperature controller shall be provided to maintain a fixed axial temperature distribution over the length of the furnace.

4.1.2.2 *Method B*—A rheostat shall be used to supply power to the outer winding. A separate rheostat and controller shall be used for the inner core winding. The basic furnace temperature level is achieved by controlling power to both inner and outer core windings. The slope of the gradient is achieved by adjusting power input to the outer core winding only. The established temperature gradient is then maintained by controlling power to the inner core winding only.

⁵ National Institute of Standards and Technology, Office of Standard Reference Materials, Room B311, Chemical Building, Gaithersburg, MD 20899.

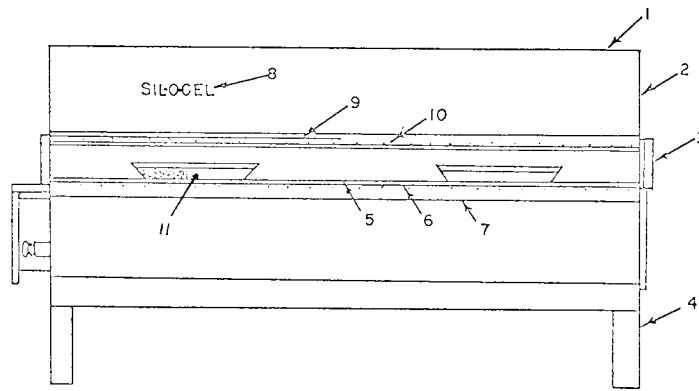

NOTE 1—See A1.1 for further description.

- | | |
|--------------------------------------|--|
| 1. Outer shell (stainless steel) | 7. Outer protection tube |
| 2. End plate (Transite) ⁴ | 8. Sil-O-Cel ⁵ insulation |
| 3. End plate (quartz) | 9. Control thermocouple (platinum/rhodium) |
| 4. Stand | 10. Heating element wire |
| 5. Inner protection tube | 11. Specimen tray |
| 6. Heating element tube | |

FIG. 1 Liquidus Furnace (Method A)

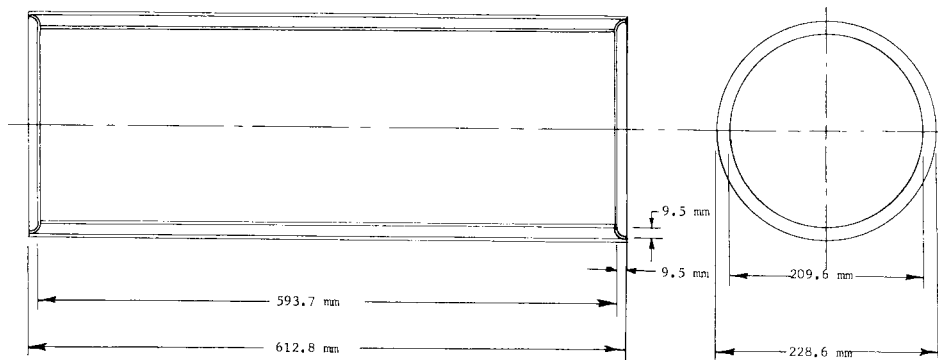

Material: 26-gage stainless steel

FIG. 2 Liquidus Furnace Shell (Method A)

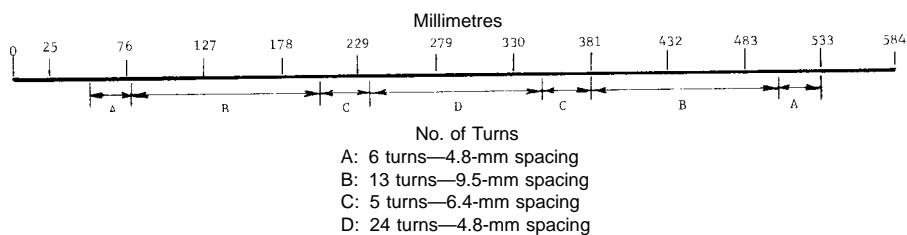

FIG. 3 Recommended Liquidus Furnace Winding (Method A)

4.1.3 *Temperature-Measuring Equipment*—Furnace temperatures shall be measured with calibrated Type R or S thermocouples in conjunction with a calibrated potentiometer, or other comparable instrumentation, capable of measurements within 0.5°C. In addition to control thermocouples, Method A requires an unshielded supported thermocouple for insertion into the furnace chamber to determine temperature gradients, and Method B requires five thermocouples mounted in the specimen support fixture as shown in Fig. 6. An alternative method is to attach (spot weld) the thermocouples to a fixed platinum or platinum alloy plate which supports the tray or perforated plate. A solid-state digital thermometer capable of

the measurement accuracy specified may be used for temperature measurement.

4.1.4 *Microscope*—A microscope capable of resolution of at least 5 μm at 100× is required. A petrographic microscope is preferred for ease of crystal identification under polarized light.

4.1.5 *Additional Equipment for Method A:*

4.1.5.1 Laboratory stand to support thermocouple horizontally (see Fig. 7).

4.1.5.2 Trough-type platinum boats (see Fig. 8 and Annex A2).

4.1.5.3 Reshaping die for trough-type boats (see Fig. 8).

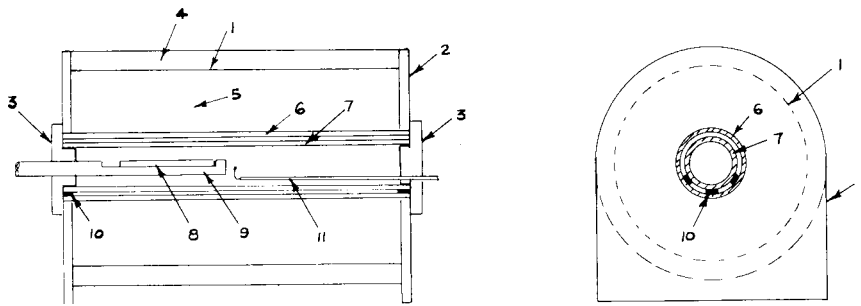

NOTE 1—See A1.2 for further description.

- | | |
|---|---|
| <ul style="list-style-type: none"> 1. Stainless steel shell 2. End plates (Transite⁴) 3. End seals (Fiberfrax⁶) 4. Insulating cover (Fiberfrax⁶) 5. Refractory or Sil-O-Cel insulation 6. Outer heating element tube | <ul style="list-style-type: none"> 7. Inner heating element tube 8. Perforated platinum tray 9. Mullite tube of riding device 10. Alumina spacers 11. Controlling thermocouple |
|---|---|

FIG. 4 Liquidus Furnace (Method B)

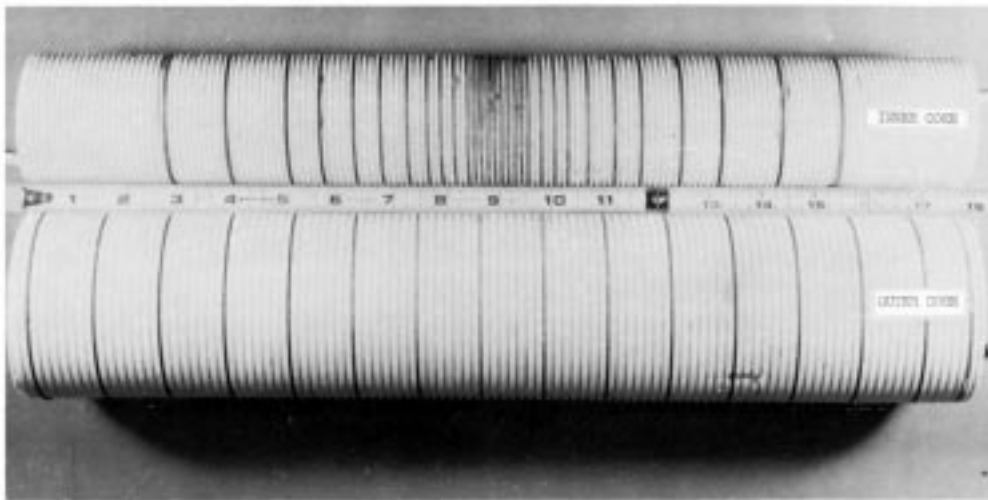
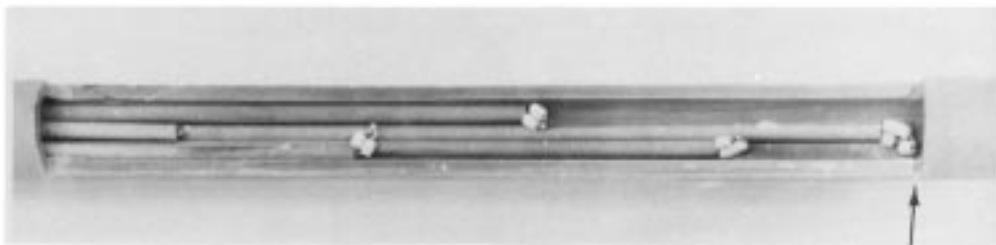

FIG. 5 Liquidus Furnace Heating Cores (Method B)



NOTE 1—Hottest thermocouple positioned at forward edge of cut-away section of mullite tube.

FIG. 6 Specimen Support Fixture (Method B)

4.1.5.4 Stainless steel mortar and pestle. (*The stainless steel must be magnetic.*)

4.1.5.5 Sieve, U.S. Standard, No. 20 (850- μ m) with receiver pan.

4.1.5.6 Small horseshoe magnet.

4.1.5.7 Glass vials with covers.

4.1.5.8 Graduated measuring rod.

4.1.5.9 Stainless steel tongs.

4.1.5.10 Other minor items as described in the text.

4.1.6 *Additional Equipment for Method B:*

4.1.6.1 Riding device for simultaneously holding and positioning multiple thermocouples and a perforated platinum tray. This device is provided with leveling screws, a means for lateral adjustment, and a positive stop for precisely locating the boat and thermocouples within the furnace. The device shown in Fig. 9 meets these requirements.

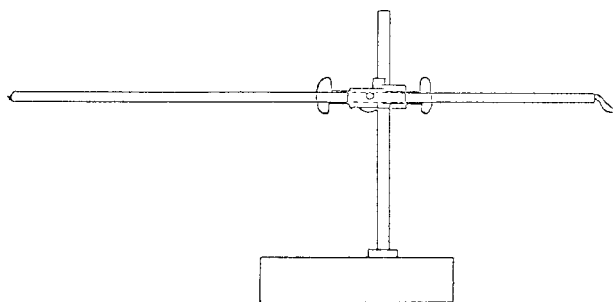

FIG. 7 Thermocouple and Support (Method A)

4.1.6.2 Perforated platinum trays (see Fig. 10 and Annex A2).

4.1.6.3 Stainless steel mortar and pestle.

4.1.6.4 Sieves, U.S. Standard, No. 8 (2.36-mm) and No. 12 (1.70-mm) with receiver pan.

4.1.6.5 Glass vials with covers.

4.1.6.6 Stainless steel pointed tongs.

4.1.6.7 Other minor items as shown in illustrations and described in the text.

5. Preparation of Test Specimens

5.1 Select a mass of glass of approximately 70 g. Break the sample into pieces of a size that will fit into the mortar. Clean the sample with acetone, rinse with distilled water, and dry. Clean the mortar and pestle, sieve, and magnet in the same manner (Note 2). Crush the sample, using the mortar and pestle, by using a hammer or other suitable means.

NOTE 2—From this point on, contact with bare hands or other source of contamination must be avoided.

5.2 *Method A*—Pour the crushed sample onto a No. 20 (850- μ m) sieve. Retain the material not passing the sieve and repeat the crushing procedure until all the glass has been reduced to a size to pass through the sieve into the receiver pan. With the test specimen still in the pan, move the magnet throughout the specimen to remove magnetic fragments that may have been introduced during crushing. If not to be tested immediately, place the specimen in a covered glass vial or other suitable container.

5.3 *Method B*—Pour the crushed sample onto a No. 8 (2.36-mm) sieve fitted over a No. 12 (1.70-mm) sieve and receiver pan. Retain only that part of the sample not passing through the No. 12 sieve. That glass retained on the No. 8 sieve may be recrushed if necessary to increase the No. 12 sieve sample size. Discard the fines passing through to the receiver pan. If not to be tested immediately, place the specimen in a covered glass vial or other suitable container.

6. Procedure

6.1 *Method A*—Fill to one-half to three-quarters full two specimen trays that are free of cracks, pits, or adhering glass with the crushed glass specimen. Distribute evenly over the length of each tray. Place the filled trays in the furnace, one on either side of the maximum temperature point, and locate so that their centers are at the predetermined gradient temperature level corresponding to the liquidus temperature, if known. Record the location of the trays in the furnace. Either the

single- or the double-core furnace may be used. Modify the double-core furnace design to accommodate two samples by providing two riding devices and means for insertion from both ends of the furnace.

6.2 *Method B*—Use one or two perforated specimen trays that are free of cracks, pits, or adhering glass. Using the pointed stainless steel tongs or tweezers, select chips of the sample from the No. 12 (1.70-mm) sieve and place one in each of the drilled holes in each tray. Position a tray in the cut-away section of the mullite tube on the riding device with the double row of holes forward (toward the hot end), and the forward end of the tray indexed precisely over the most forward of the five thermocouples against the forward edge of the cut-away section, as shown in Fig. 4. An alternative method is to move the furnace into position around a fixed tray. One sample in one tray supported by one riding device may be tested in the double-core furnace. Two samples may be tested simultaneously by modifying the furnace design to provide for insertion from both ends. Carefully feed the riding device containing the tray into the furnace until the prepositioned stop plate is contacted. Close the end opening of the furnace around the riding device with suitable insulation.

6.3 *Treatment Time*—Leave the specimens in the furnace until equilibrium between the crystal and glassy phases is established. The time required is a function of the glass composition. Twenty-four hours is sufficient for many glasses, but some glasses may take days to reach equilibrium. Complete crystallization of the specimen indicates insufficient temperature in heat treatment. Total lack of crystallization indicates insufficient time or excess temperature.

6.4 *Temperature Gradient*—Determine the temperature gradients over the lengths of the specimens at the end of the heating period just prior to removal from the furnace.

6.4.1 *Single-Core Furnace*—Establish a temperature profile over the length of each tray by using a traveling unshielded Type R or S thermocouple supported horizontally as near the top of the trays as practical and centered over their widths. Start the probe at the hotter end of each tray, toward the center of the furnace, and make successive temperature readings along the tray length at 1/2-in. (12.7-mm) intervals. Allow the thermocouple temperature to stabilize in each position as indicated by constancy of temperature over a period of time. Record the temperature of each thermocouple position to the nearest 1°C as related to tray position, and plot as in Fig. 11.

6.4.2 *Double-Core Furnace*—Obtain the temperature profile as related to tray position from readings of the five Type R or S thermocouples mounted in fixed positions in the riding device.

6.5 Method A:

6.5.1 Remove the specimens from the furnace, free from the trays, cool, and examine under a microscope for evidence of crystallization. If the single-core furnace has been used for the heat treatment, grasp the trays with smooth-faced forceps and drag outside the furnace onto a heat-resistant flat surface. If the double-core furnace has been used, retract the riding device from the furnace, remove the tray, and place it on the heat-resistant flat surface. Immediately upon removal and before the glass specimen hardens, bend the sidewalls of the

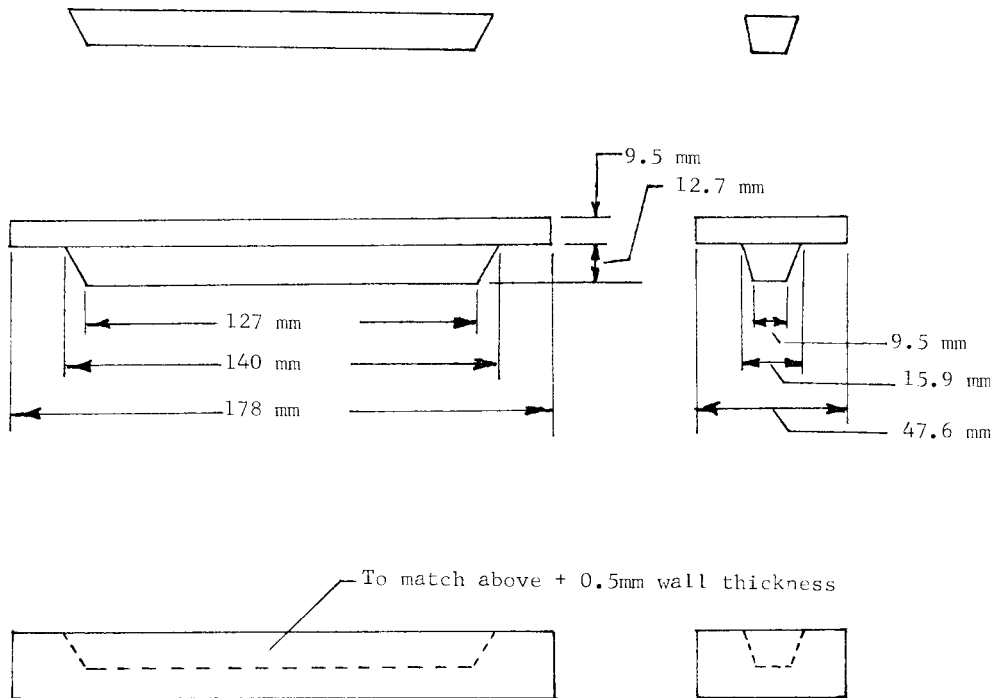
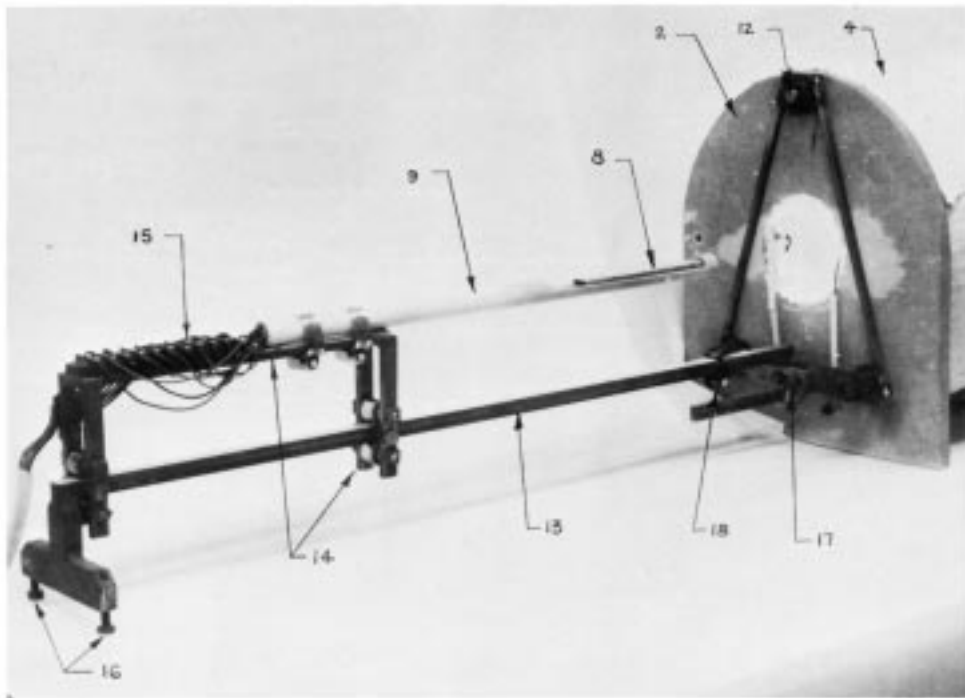

FIG. 8 Platinum Tray and Reforming Die (Method A)



NOTE 1—See A1.2 and Fig. 4 for legend.

FIG. 9 Riding Device (Method B)

tray slightly inward at 1-in. (25.4-mm) intervals along its length. After the specimen has solidified, but is still quite hot, bend the sidewalls outward to separate the specimen from the tray. Repeat the inward and outward bending as needed to separate the specimen from the tray. Finally, bend the sides of the tray to nearly their original shape, and invert the tray to

remove the specimen. Tapping the top of the tray on a hard, flat surface is usually required to remove the specimen. Immediately return the hot specimen to its original position in the tray to avoid thermal shock breakage and to preserve orientation. Cool the specimen to room temperature and mark to identify either the end that was hotter or cooler when in the furnace.

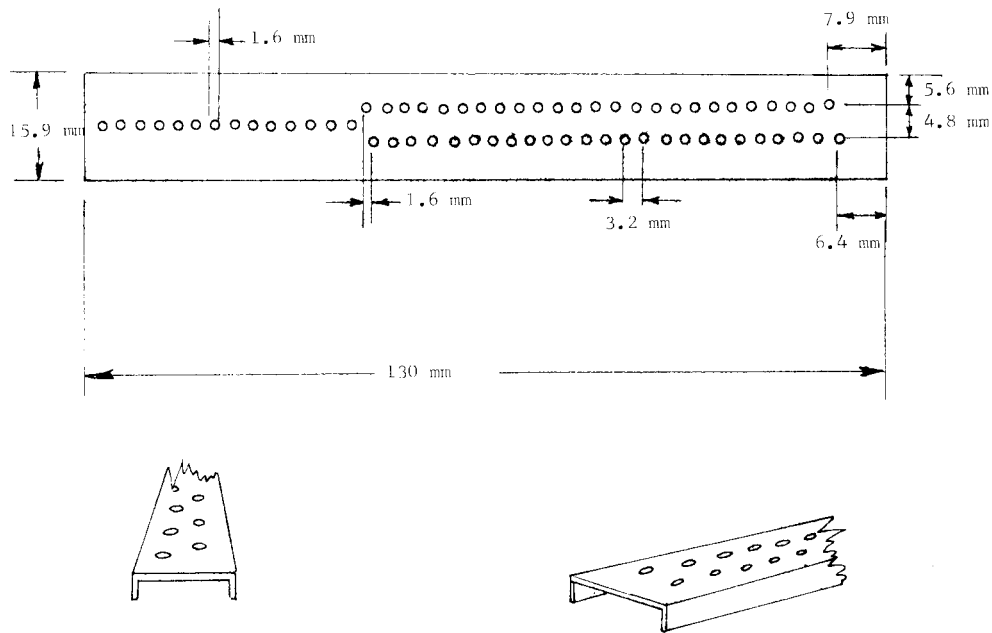

FIG. 10 Platinum Tray for Holding Glass (Method B)

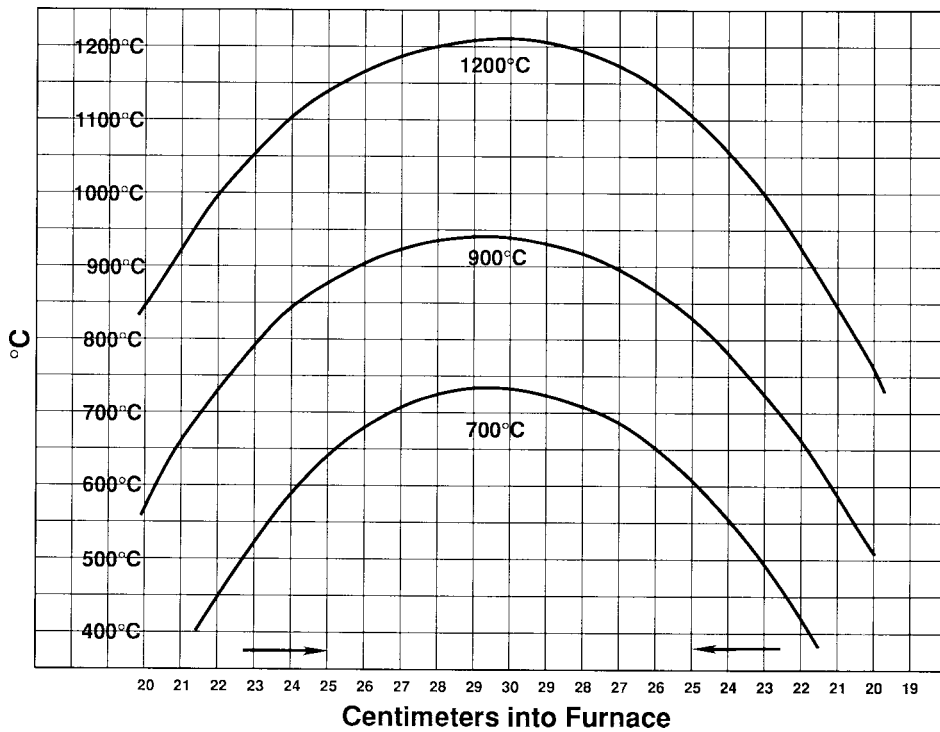

FIG. 11 Liquidus Furnace Temperature Gradient

6.5.2 Remove the cooled specimen from the tray and place it on the stage of a microscope with the bottom surface upward. Apply a refractive index matching fluid to this surface. These requirements permit clearer observation of the specimen interior, avoiding interference due to devitrification or compositional changes or both at the top surface. Use of crossed Nicol prisms with a full-wave tint plate aids in the observation of any crystals. Scan the bottom surface region of the specimen from the cold toward the hot end. Observe beneath the surface, but not deeper than 1/8 in. (3 mm), and in the middle three fourths

of the width of the specimen. Usually, a region will be found where the crystals decrease in number and size as the crystal frontier is approached. Continue the search beyond this, toward the hotter end of the specimen, until the last crystal is observed, disregarding those crystals that are close to the edges of the specimen. Mark the position of this last crystal as the liquidus point. Return the marked specimen, properly oriented, to the tray from which it was taken.

6.6 *Method B*—Withdraw the riding device from the furnace and remove with flat tongs the tray containing the

specimen from the mullite tube and place on a heat-resistant flat surface to cool to room temperature. Place the cooled tray, with the specimen in it, in a normal upright position on the stage of a microscope. Examine the glass in each hole, starting at the cold end of the tray and progressing toward the hot end. Mark the tray at the point where the last crystal is observed, disregarding crystals near the edges of the holes. This is the liquidus point.

of devitrification within the body of the glass, surface devitrification can be studied even though it may be of a different crystalline makeup. If of interest, the surface may be examined and an apparent boundary temperature can be so listed in the report.

8. Report

8.1 Report the following information:

METHOD A

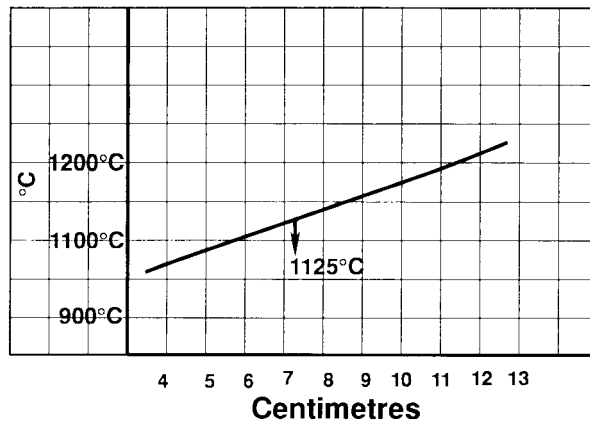

METHOD B

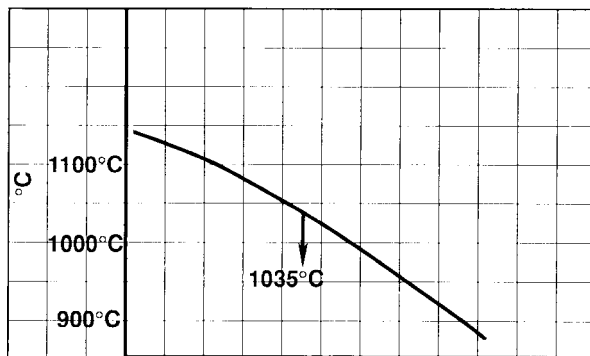

**Actual Thermocouple Spacing
Centimetres**

FIG. 12 Interpolation of Liquidus Temperature

6.7 *Liquidus Temperature*—Prepare individual graphs, one for each temperature-gradient survey, with temperatures as ordinates and thermocouple junction positions as full-scale abscissas. Draw smooth curves through the temperature points as in Fig. 12. Lay a boat on its respective temperature graph and precisely position with respect to the abscissa in accordance with its position at the time of making the gradient measurements. Read from the graph the temperature corresponding to the marked liquidus point. This is the liquidus temperature. The agreement in results between two duplicate determinations should be within 10°C. Calculate the mean liquidus temperature representing two or more determinations.

7. Surface Crystallization

7.1 Although the primary intent of this test is the evaluation

- 8.1.1 Designation of the glass, source, and date,
- 8.1.2 Average liquidus temperature, and
- 8.1.3 Date of test and name of operator.

9. Precision and Bias

9.1 These methods will generally yield liquidus temperatures between two boats tested simultaneously that differ less than 10°C. Precision of the liquidus temperature between two independent tests in the same furnace is generally within 10°C.

9.2 The liquidus apparatus may be certified or calibrated using SRM 773.

10. Keywords

- 10.1 crystallization; glass; gradient furnace; liquidus

ANNEXES

(Mandatory Information)

A1. DESCRIPTION OF LIQUIDUS FURNACE COMPONENTS

A1.1 Components for Liquidus Furnace Used in Method A (see Fig. 1)

A1.1.1 *Outer Shell*—26-gage stainless steel, rolled and welded, 228.6-mm (9-in.) outside diameter by 209.6-mm (8¼-in.) inside diameter by 612.8 mm (24⅞ in.) long, double-lined.

A1.1.2 *End Plate*—Transite⁶ 6.35 mm (¼ in.) thick, 222.3-mm (8¾-in.) diameter, with loose fit for expansion.

A1.1.3 *End Plate*—Window, polished quartz or borosilicate-type glass, 44.5 by 44.5 by 6.35 mm (1¾ by 1¾ by ¼ in.) thick, with a 6.35-mm (¼-in.) hole in the center.

A1.1.4 *Stand*—25.4-mm (1-in.) angle iron.

A1.1.5 *Inner Protection Tube*—33.3 mm (1⅝ in.) in outside diameter by 28.6-mm (1⅛-in.) inside diameter by 609.6 mm (24 in.) long, made of high-purity alumina.

A1.1.6 *Heating Element Tube*—50.8 mm (2 in.) in outside diameter by 38.1-mm (1½-in.) inside diameter by 596.9 mm (23½ in.) long, made of high-purity alumina.

A1.1.7 *Outer Protection Tube*—69.9 mm (2¾ in.) in outside diameter by 57.2-mm (2¼-in.) inside diameter by 596.9 mm (23½ in.) long.

A1.1.8 *Insulation*—Infusorial earth⁷ for temperatures up to 1300°C. High purity bubble alumina is recommended for higher temperatures.

A1.1.9 *Control Thermocouple*—Type R (platinum versus platinum plus 13 % rhodium) or Type S (platinum versus platinum plus 10 % rhodium), 457.2 mm (18 in.) long, 0.51 mm (0.020 in.) in diameter, in porcelain sleeving. The thermocouple should fit between the heating element tube and the inner protection tube, and be placed at the center of the furnace length.

A1.1.10 *Element Wire*—80 % platinum-20 % rhodium resistance wire, 0.81-mm (0.032-in.) diameter, to be wound for gradient temperature (see Fig. 2), is suggested. Approximate length of wire needed is 19.7 m (50 ft).

NOTE A1.1—All parts should be assembled for a *loose* fit to avoid breakage on heat-up.

A1.1.11 *Platinum Tray*—See Fig. 8.

A1.2 Components for Liquidus Furnace Used in Method B (see Fig. 4 and Fig. 5)

A1.2.1 *Outer Shell*—15 or 16-gage stainless steel, rolled

and welded, 254-mm (10-in.) diameter by 431.8 mm (17 in.) long.

A1.2.2 *End Plates*—Transite⁵, 12.7 mm (½ in.) thick, 304.8 mm (12 in.) wide, by 330.2 mm (13 in.) high, with 152.4-mm (6-in.) radius at top, and a 95.3-mm (3¾-in.) diameter hole centered 152.4 mm from the top.

A1.2.3 Fiberfrax⁵ pad or other suitable insulation preformed for seal.

A1.2.4 *Outer Insulation*—Fiberfrax⁸ blanket 431.8 by 800.1 by 25.4 mm (17 by 31½ by 1 in.) thick, with one layer tied or banded in place.

A1.2.5 Infusorial earth⁶ or other suitable high-temperature refractory.

A1.2.6 *Outer Heating Element Tube*—76.2-mm (3-in.) bore, 457.2 mm (18 in.) long, 1.59 by 1.59 mm (⅙ by ⅙ in.) spiral grooved, making 2.4 turns per centimetre (6 turns per inch), made of 98.8 % Al₂O₃.

A1.2.7 *Inner Heating Element Tube*—50.8-mm (2-in.) bore, 457.2 mm (18 in.) long, 1.59 by 1.59 mm (⅙ by ⅙ in.) spiral grooved, making 3.1 turns per centimetre (8 turns per inch), made of 98.8 % Al₂O₃.

A1.2.8 *Perforated Platinum Tray* (see Fig. 10).

A1.2.9 *Mullite Thermocouple Protection Tube*—19.1 mm (¾ in.) by 457.2 mm (18 in.) long; closed end cut-off: 171.5-mm (6¾-in.) half section cut away to seat platinum boat.

A1.2.10 *Spacers Between Heating Tubes*—Pieces of Al₂O₃.

A1.2.11 *Control Thermocouple*—Type R (platinum versus platinum plus 13 % rhodium) or Type S (platinum versus platinum plus 10 % rhodium), in porcelain sleeving of sufficient length to reach the center of the furnace length. It should be centered as nearly as practical inside the inner heating element.

A1.2.12 *Steel Tie Rods*—Three, all thread, 12.7 by 508 mm (½ by 20 in.).

A1.2.13 *Steel Riding Rod*—12.7 by 12.7 by 711.2 mm (½ by ½ by 28 in.) long.

A1.2.14 *Mullite Tube Support*—254 mm (10 in.) long with roller bearings and other construction typically as shown in Fig. 9.

A1.2.15 *Terminal Block*.

A1.2.16 *Leveling Screws*.

A1.2.17 *Lateral Alignment Screws*.

A1.2.18 *Adjustable Stop for Riding Device*.

⁶ Trademark of the Johns-Manville Products Corp.

⁷ Sil-O-Cel, manufactured by the Johns-Manville Products Corp., has been found suitable for this purpose.

⁸ Trademark of The Carborundum Co.

A2. CARE OF THE PLATINUM TRAYS

A2.1 The condition of the platinum trays is very important. A trough-type tray, to be satisfactory for liquidus determinations, should have no holes or cracks in the bottom or side walls. Both types of boat should be free of adhering glass or other foreign matter, chiefly iron.

A2.2 *Cleaning the Boats*—Clean the trays by immersing them in hydrofluoric acid for 24 h or longer so that the adhering glass can be softened and removed. Then rinse the trays in water, and use a soft brush to remove any traces of glass.

A2.3 *Reshaping the Trough-Type Trays*—After all residual glass has been removed, place the dry trough-type tray in the precleaned stainless steel reforming die. With the preforming die resting on a solid surface, give the top of the die several taps with the small plastic hammer. See Fig. 8. After the reshaped tray is removed, apply a thin coating of petroleum jelly to the surfaces of the die prior to storage.

A2.4 *Perforated Platinum Trays*—After removing all glass residue, the perforated trays are only required to be returned to

their open channel shape with approximately 90° angles between legs and perforated top. The perforated top can be returned to a flat plane by inverting the tray on a hard flat surface, laying a stainless steel bar on the inside of the boat, and tapping it gently with a light hammer.

A2.5 *Iron Contamination Removal*—Use tongs to place the trays into concentrated hydrochloric acid. After a half hour or more, any residual iron which may have been picked up from reforming dies or other source is dissolved. Upon removal from the acid, rinse the tray thoroughly with tap water, then distilled water, and dry.

A2.6 *Contamination of Clean Trays*—Do not allow materials other than future test samples to come in contact with the interior surfaces of trough-type trays or with the perforated surfaces of trays of that type after cleaning. This especially includes contact with the fingers while handling cleaned trays.

The American Society for Testing and Materials takes no position respecting the validity of any patent rights asserted in connection with any item mentioned in this standard. Users of this standard are expressly advised that determination of the validity of any such patent rights, and the risk of infringement of such rights, are entirely their own responsibility.

This standard is subject to revision at any time by the responsible technical committee and must be reviewed every five years and if not revised, either reapproved or withdrawn. Your comments are invited either for revision of this standard or for additional standards and should be addressed to ASTM Headquarters. Your comments will receive careful consideration at a meeting of the responsible technical committee, which you may attend. If you feel that your comments have not received a fair hearing you should make your views known to the ASTM Committee on Standards, 100 Barr Harbor Drive, West Conshohocken, PA 19428.