



Standard Test Method for Compressive Properties of Unidirectional Polymer Matrix Composite Materials Using a Sandwich Beam¹

This standard is issued under the fixed designation D 5467/D 5467M; the number immediately following the designation indicates the year of original adoption or, in the case of revision, the year of last revision. A number in parentheses indicates the year of last reapproval. A superscript epsilon (ϵ) indicates an editorial change since the last revision or reapproval.

1. Scope

1.1 This test method covers the in-plane compressive properties of polymer matrix composite materials reinforced by high-modulus fibers in a sandwich beam configuration. The composite material forms are limited to continuous-fiber composites of unidirectional orientation. This test procedure introduces compressive load into a thin skin bonded to a thick honeycomb core with the compressive load transmitted into the sample by subjecting the beam to four-point bending.

1.2 This procedure is applicable primarily to laminates made from prepreg or similar product forms. Other product forms may require deviations from the test method.

1.3 The values stated in either SI units or inch-pound units are to be regarded separately as standard. Within the text the inch-pounds units are shown in brackets. The values stated in each system are not exact equivalents; therefore, each system must be used independently of the other. Combining values from the two systems may result in nonconformance with the standard.

NOTE 1—Additional procedures for determining compressive properties of polymer matrix composites may be found in Test Methods D 3410/D 3410M and D 695.

1.4 *This standard does not purport to address all of the safety concerns, if any, associated with its use. It is the responsibility of the user of this standard to establish appropriate safety and health practices and determine the applicability of regulatory limitations prior to use.*

2. Referenced Documents

2.1 ASTM Standards:²

D 695 Test Method for Compressive Properties of Rigid Plastics

D 792 Test Methods for Density and Specific Gravity (Relative Density) of Plastics by Displacement
D 883 Terminology Relating to Plastics
D 2584 Test Method for Ignition Loss of Cured Reinforced Resins
D 2734 Test Method for Void Content of Reinforced Plastics
D 3171 Test Method for Constituent Content of Composite Materials
D 3410/D 3410M Test Method for Compressive Properties of Polymer Matrix Composite Materials with Unsupported Gage Section by Shear Loading
D 3878 Terminology for Composite Materials
D 5229/D 5229M Test Method for Moisture Absorption Properties and Equilibrium Conditioning of Polymer Matrix Composite Materials
E 4 Practices for Force Verification of Testing Machines
E 6 Terminology Relating to Methods of Mechanical Testing
E 111 Test Method for Young's Modulus, Tangent Modulus, and Chord Modulus
E 122 Practice for Calculating Sample Size to Estimate, With a Specified Tolerable Error, the Average for a Characteristic of a Lot or Process
E 177 Practice for Use of the Terms Precision and Bias in ASTM Test Methods
E 251 Test Methods for Performance Characteristics of Metallic Bonded Resistance Strain Gages
E 456 Terminology Relating to Quality and Statistics
E 1237 Guide for Installing Bonded Resistance Strain Gages
E 1309 Guide for Identification of Fiber-Reinforced Polymer-Matrix Composite Materials in Databases
E 1434 Guide for Recording Mechanical Test Data of Fiber-Reinforced Composite Materials in Databases
E 1471 Guide for Identification of Fibers, Fillers, and Core Materials in Computerized Material Property Databases

3. Terminology

3.1 *Definitions*—Terminology D 3878 defines terms relating to high-modulus fibers and their composites. Terminology D 883 defines terms relating to plastics. Terminology E 6 defines terms relating to mechanical testing. Terminology

¹ This test method is under the jurisdiction of ASTM Committee D30 on Composite Materials and is the direct responsibility of Subcommittee D30.04 on Lamina and Laminate Test Methods.

Current edition approved Mar. 1, 2004. Published March 2004. Originally approved in 1993. Last previous edition approved in 1997 as D 5467/D 5467M – 97^{ε1}.

² For referenced ASTM standards, visit the ASTM website, www.astm.org, or contact ASTM Customer Service at service@astm.org. For *Annual Book of ASTM Standards* volume information, refer to the standard's Document Summary page on the ASTM website.

E 456 and Practice E 177 define terms relating to statistics. In the event of a conflict between terms, Terminology D 3878 shall have precedence over the other terminology standards.

3.2 Definitions of Terms Specific to This Standard:

3.2.1 *nominal value, n*—a value, existing in name only, assigned to a measurable property for the purpose of convenient designation. Tolerances may be applied to a nominal value to define an acceptable range for the property.

3.2.2 *orthotropic material, n*—a material with a property of interest that, at a given point, possesses three mutually perpendicular planes of symmetry defining the principal material coordinate system for that property.

3.2.3 *principal material coordinate system, n*—a coordinate system with axes that are normal to the planes of symmetry that exist within the material.

3.2.4 *reference coordinate system, n*—a coordinate system for laminated composites used to define ply orientations. One of the reference coordinate system axes (normally the Cartesian *x*-axis) is designated the reference axis, assigned a position, and the ply principal axis of each ply in the laminate is referenced relative to the reference axis to define the ply orientation for that ply.

3.2.5 *specially orthotropic, adj*—a description of an orthotropic material as viewed in its principal material coordinate system. In laminated composites, a specially orthotropic laminate is a balanced and symmetric laminate of the $(0_i/90_j)_{ns}$ family as viewed from the reference coordinate system, such that the membrane-bending coupling terms of the stress-strain relation are zero.

3.2.6 *transition strain, $\epsilon^{transition}$, n*—the strain value at the mid-range of the transition region between the two essentially linear portions of a bilinear stress-strain or strain-strain curve

(a transverse strain-longitudinal strain curve as used for determining Poisson's ratio).

3.3 Symbols:

3.3.1 *a*—distance between neutral axes of test and opposite facesheets.

3.3.2 *A*—cross-sectional area of test facesheet.

3.3.3 *CV*—sample coefficient of variation, in percent.

3.3.4 *E_o*—modulus of elasticity of the opposite facesheet in the test direction.

3.3.5 *E_f*—modulus of elasticity of the test facesheet in the test direction.

3.3.6 *F^{cu}*—ultimate compressive strength.

3.3.7 *G_{xz}*—through-thickness shear modulus of elasticity.

3.3.8 *h_c*—thickness of core.

3.3.9 *σ^c*—compressive normal stress.

4. Summary of Test Method

4.1 A sandwich beam composed of two facesheets separated by a relatively deep honeycomb core, as shown in Fig. 1, is loaded in four-point bending. The main component of the compression test specimen is the face sheet that is loaded in compression during flexure, with the material direction of interest oriented along the length of the beam. The other facesheet is of a material and size carefully selected to preclude its influence on the test results. The ultimate compressive strength of the material is determined from the load at which the test facesheet of the sandwich beam fails in an acceptable compression failure mode. If the specimen strain is monitored with strain or deflection transducers then the stress-strain response of the material can be determined, from which can be derived the compressive modulus of elasticity for this configuration.

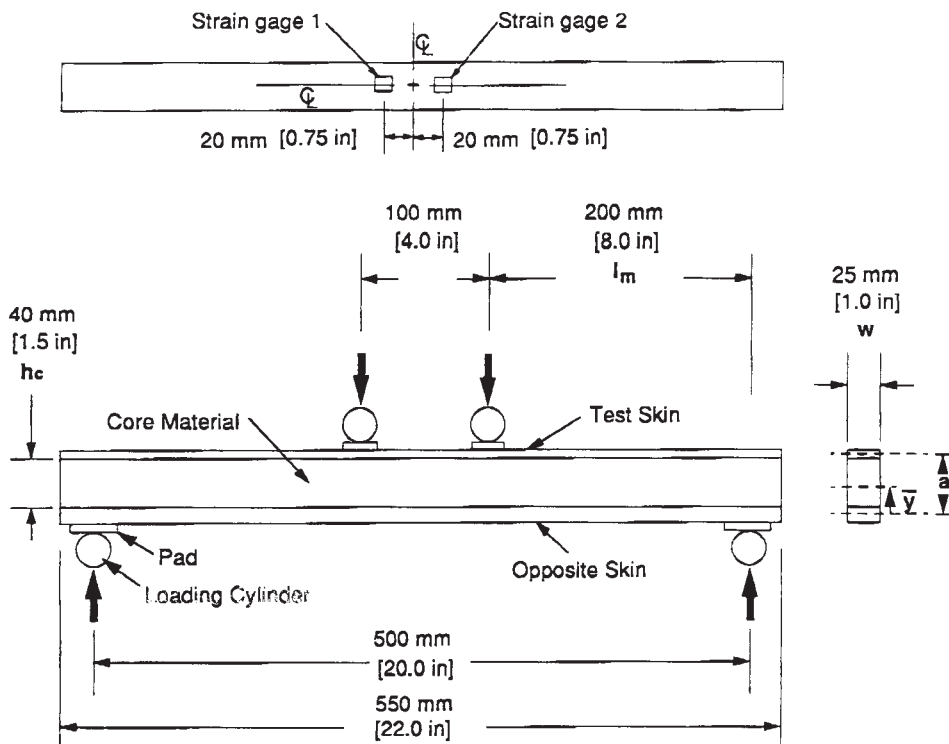

FIG. 1 Longitudinal Compression Sandwich Beam Test Specimen

5. Significance and Use

5.1 This test method is designed to produce membrane compressive property data for material specifications, research and development, quality assurance, and structural design and analysis. Factors that influence the compressive response and should therefore be reported include the following: material, methods of material and specimen preparation, specimen conditioning, environment of testing, specimen alignment, speed of testing, time at reinforcement. Properties, in the test direction, that may be obtained from this test method include:

- 5.1.1 Ultimate compressive strength,
- 5.1.2 Ultimate compressive strain,
- 5.1.3 Compressive (linear or chord) modulus of elasticity, and
- 5.1.4 Transition strain.

6. Interferences

6.1 *Test Method Sensitivities*—Compressive strength for a single material system has been shown to differ when determined by different test methods. Such differences can be attributed to specimen alignment effects, specimen geometry effects, and fixture effects even though efforts have been made to minimize these effects.

6.2 *Material and Specimen Preparation*—Compressive modulus, and especially compressive strength, are sensitive to poor material fabrication practices, damage induced by improper coupon machining, and lack of control of fiber alignment. Fiber alignment relative to the specimen coordinate axis should be maintained as carefully as possible, although no standard procedure to insure this alignment exists. Procedures found satisfactory include the following: fracturing a cured unidirectional laminate near one edge parallel to the fiber direction to establish the [0] direction or laying in small filament count tows of contrasting color fiber (aramid in carbon laminates and carbon in aramid or glass laminates) parallel to the [0] direction either as part of the prepreg production or as part of panel fabrication.

6.3 *Calculation*—Stress equations are based on beam theory.

7. Apparatus

7.1 *Micrometers*—The micrometer(s) shall use a suitable size diameter ball-interface on irregular surfaces such as the bag-side of a laminate, and a flat anvil interface on machined edges or very smooth tooled surfaces. The accuracy of the instruments shall be suitable for reading to within 1 % of the sample width and thickness. For typical specimen geometries, an instrument with an accuracy of $\pm 2.5 \mu\text{m}$ [± 0.0001 in.] is desirable for thickness measurement, while an instrument with an accuracy of $\pm 25 \mu\text{m}$ [± 0.001 in.] is desirable for width measurement.

7.2 *Compressive Fixture*—A fixture of four loading cylinders or cylindrical supports capable of loading the sandwich beam as shown in Fig. 1. The fixture shall be installed between the steel platens of the testing machine. To avoid local crushing or failure as a result of stress concentrations under the loading cylinders, the diameter of loading cylinders may be up to 1.5 times the sandwich thickness, and loading pads may be needed under the loading cylinders (see 11.6).

7.3 *Testing Machine*—The testing machine shall be in conformance with Practices E 4 and shall satisfy the following requirements:

7.3.1 *Testing Machine Heads*—The testing machine shall have two loading heads, with at least one movable along the testing axis.

7.3.2 *Drive Mechanism*—The testing machine drive mechanism shall be capable of imparting to the movable head a controlled displacement rate with respect to the stationary head. The displacement rate of the movable head shall be capable of being regulated as specified in 11.3.

7.3.3 *Load Indicator*—The testing machine load-sensing device shall be capable of indicating the total load being carried by the test specimen. This device shall be essentially free from inertia lag at the specified rate of testing and shall indicate the load with an accuracy over the load range(s) of interest of within ± 1 % of the indicated value, as specified by Practices E 4. The load range(s) of interest may be fairly low for modulus evaluation, much higher for strength evaluation, or both, as required.

NOTE 2—Obtaining precision load data over a large range of interest in the same test, such as when both elastic modulus and ultimate load are being determined, place extreme requirements on the load cell and its calibration. For some equipment, a special calibration may be required. For some combinations of material and load cell, simultaneous precision measurement of both elastic modulus and ultimate strength may not be possible, and measurement of modulus and strength may have to be performed in separate tests using a different load cell range for each test.

7.4 *Strain-Indicating Device*—Strain data, if required, shall be determined by means of strain gages.

7.4.1 *Bonded Resistance Strain Gages*—Strain gage selection is a compromise based on the procedure and the type of material to be tested. Strain gages should have an active grid length of 3 mm [0.125 in.] or less; (1.5 mm [0.06 in.] is preferable). Gage calibration certification shall comply with Test Methods E 251. Some guidelines on the use of strain gages on composites are presented below, with a general discussion on the subject in Footnote 8.³

7.4.1.1 Surface preparation of fiber-reinforced composites in accordance with Practice E 1237 can penetrate the matrix material and cause damage to the reinforcing fibers, resulting in improper coupon failures. Reinforcing fibers shall not be exposed or damaged during the surface preparation process. Consult the strain gage manufacturer regarding surface preparation guidelines and recommended bonding agents for composites.

7.4.1.2 Select gages having larger resistances to reduce heating effects on low-conductivity materials. Resistances of 350 Ω or higher are preferred. Use the minimum possible gage excitation voltage consistent with the desired accuracy (1 to 2 V is recommended) to reduce further the power consumed by the gage. Heating of the coupon by the gage may affect the performance of the material directly, or it may affect the indicated strain as a result of a difference between the gage

³ Pendleton, R. P. and Tuttle, M. E., *Manual on Experimental Methods for Mechanical Testing of Composites*, Society for Experimental Mechanics, Bethel, CT, 1989.

temperature compensation factor and the coefficient of thermal expansion of the coupon material.

7.4.1.3 Temperature compensation is recommended when testing at Standard Laboratory Atmosphere. Temperature compensation is required when testing in nonambient temperature environments. When appropriate, use a traveler coupon (dummy calibration coupon) with identical lay-up and strain gage orientations for thermal strain compensation.

7.4.1.4 Consider the transverse sensitivity of the selected strain gage. Consult the strain gage manufacturer for recommendations on transverse sensitivity corrections.

7.5 *Conditioning Chamber*—When conditioning materials in other than ambient laboratory environments, a temperature/vapor-level controlled environmental conditioning chamber is required that shall be capable of maintaining the required relative temperature to within $\pm 3^\circ\text{C}$ [$\pm 5^\circ\text{F}$] and the required relative vapor level to within $\pm 5\%$. Chamber conditions shall be monitored either on an automated continuous basis or on a manual basis at regular intervals.

7.6 *Environmental Test Chamber*—An environmental test chamber is required for test environments other than ambient testing laboratory conditions. This chamber shall be capable of maintaining the gage section of the test specimen within $\pm 3^\circ\text{C}$ [$\pm 5^\circ\text{F}$] of the required test temperature during the mechanical test. In addition, the chamber may have to be capable of maintaining environmental conditions such as fluid exposure or relative humidity during the test (see 11.4).

8. Sampling and Test Specimens

8.1 *Sampling*—Test at least five specimens per test condition unless valid results can be gained through the use of fewer specimens, such as in the case of a designed experiment. For statistically significant data the procedures outlined in Practice E 122 should be consulted. The method of sampling shall be reported.

8.2 *Geometry*—The test specimen shall be a rectangular bonded beam as shown in Fig. 1, with a unidirectional composite test skin. Recommended facesheet and beam core geometry and material specifications for carbon reinforced $[0]_{nT}$ and $[90]_{nT}$ test coupons are provided in Table 1. The facesheets are bonded to the core using a structural adhesive as described in 8.3.1. If unacceptable failure modes for the carbon reinforced coupons occur, or if alternate reinforcement fibers are to be used (glass, aramid, boron, and so forth), then facesheet, beam core, and overall specimen geometry shall be designed to induce compressive failure of the test facesheet.

NOTE 3—If specimens are to undergo environmental conditioning to equilibrium, then another *traveler* coupon sized according to boundary conditions consistent with one-sided absorption shall be used to determine when equilibrium has been reached for the specimens being conditioned. Suggested approaches include using a facesheet two times the test facesheet thickness or using a facesheet of the same thickness as the test skin with foil masking one side.

8.3 Specimen Preparation:

8.3.1 *Panel Fabrication*—Individual test specimens may be fabricated by either preparing sandwich panels larger than the individual specimens and machining specimens from these panels or by bonding facesheets to beam cores that both have the final specimen dimensions before bonding. For either method, prepare the test facesheet by fabricating a unidirectional laminate, with the length of the panel sufficient to accommodate the final specimen length, and panel width large enough to allow the desired number of specimens. Prepare a second laminate for the opposite facesheet as recommended in Table 1 or modified as necessary to induce acceptable compressive failure of the test facesheet. Control of fiber alignment is important. Improper fiber alignment will reduce the measured properties. Erratic fiber alignment will also increase the coefficient of variation. Suggested methods of maintaining fiber alignment are discussed in 6.2. The panel preparation method used shall be reported. Bond the test facesheet laminate and opposite facesheet laminate to the beam core using a structural adhesive.

8.3.2 For preparation of test specimens from large sandwich panels, machine the sandwich beam panel into specimens of dimensions shown in Fig. 1 and Table 1. Care should be taken to avoid damaging the edge of the laminate since the compression strength is sensitive to edge damage. Milling of the specimen to clean up the edge is allowable. All edges should be visually examined for damage.

8.3.3 *Labeling*—Label the coupons so that they will be distinct from each other and traceable back to the raw material and in a manner that will both be unaffected by the test and not influence the test.

9. Calibration

9.1 The accuracy of all measuring equipment shall have certified calibrations that are current at the time of use of the equipment.

10. Conditioning

10.1 *Standard Conditioning Procedure*—Condition in accordance with Procedure C of Test Method D 5229/D 5229M;

TABLE 1 Recommended Nominal Specifications for Carbon Tape Test Facesheets

Dimension	[0] mm [in.]	[90] mm [in.]
h_f	0.8 [0.03]	1.2 [0.048]
h_c	40 [1.5]	13 [0.5]
h_o	1.6 [0.06]	1.6 [0.063]
l_m	200 [8.0]	50 [2.0]
w	25 [1.0]	25 [1.0]
Materials		
Core material	3 to 4 mm [$\frac{1}{8}$ in.] hexagonal cell size Aluminum honeycomb, w/"L" axis in span direction	3 to 4 mm [$\frac{1}{8}$ in.] hexagonal cell size Aluminum honeycomb, w/"L" axis in span direction
Opposite facesheet	Same as test facesheet	2024 Aluminum
Core density	368 kg/m ³ [23 lb/ft ³]	130 kg/m ³ [8.1 lb/ft ³]

store and test at Standard Laboratory Atmosphere ($23 \pm 3^\circ\text{C}$ [$73 \pm 5^\circ\text{F}$] and $50 \pm 10\%$ relative humidity) unless a different environment is specified as part of the experiment.

11. Procedure

11.1 *Parameters To Be Specified Before Test:*

11.1.1 The compressive coupon sampling method, coupon type and geometry, and if required, conditioning traveler coupons.

11.1.2 The compressive properties and data reporting format desired.

NOTE 4—Determine specific material property, accuracy, and data reporting requirements before test for proper selection of instrumentation and data recording equipment. Estimate operating stress and strain levels to aid in transducer selection, calibration of equipment, and determination of equipment settings.

11.1.3 The environmental conditioning test parameters.

11.1.4 If performed, the sampling method, coupon geometry, and test parameters used to determine density and reinforcement volume.

11.2 *General Instructions:*

11.2.1 Report any deviations from this test method, whether intentional or inadvertent.

11.2.2 If specific gravity, density, reinforcement volume or void volume are to be reported, then obtain these samples from the same panels as the test samples. Specific gravity and density may be evaluated by means of Test Method D 792. Volume percent of the constituents may be evaluated by one of the matrix digestion procedures of Test Method D 3171, or, for certain reinforcement materials such as glass and ceramics, by the matrix burn-off technique of Test Method D 2584. Void content may be evaluated from the equations of Test Method D 2734 and are applicable to both Test Methods D 2584 and D 3171.

11.2.3 Condition the specimens, either before or after strain gaging, as required. Condition traveler coupons if to be used.

NOTE 5—Gaging before conditioning may impede moisture absorption locally underneath the strain gage, the conditioning environment may degrade the strain gage adhesive, or both. On the other hand, gaging after conditioning may not be possible for other reasons, or the gaging activity itself may cause loss of conditioning equilibrium. The timing on when to gage coupons is left to the individual application and shall be reported.

11.2.4 Before bonding the facesheet laminates to the core, either as individual coupons or labeled panels, determine the facesheet thickness in the gage section area as the average of three measurements. Determine the individual specimen cross-sectional area as $A = w \times h$ at three places in the gage section. Record the area as the average of these three determinations in units of mm^2 [in.^2] to the individual coupons, a deep throat micrometer shall be used to measure the coupon thickness and coupon width shall be measured after cutting the individual specimens from the test panel.

11.2.5 If strain is to be measured for the [0] configuration, apply two longitudinal strain gages to the specimen test facesheet (see 7.4) as shown in Fig. 1. Apply one longitudinal gage if strain is to be measured for the [90] configuration, as shown in Fig. 2.

11.3 *Speed of Testing*—Set speed of testing so as to produce failure within 1 to 10 min from the beginning of load application. If the ultimate strain of the material cannot be reasonably estimated, conduct initial trials using standard speeds until the ultimate strain of the material and the compliance of the system are known, and the strain rate or crosshead can be adjusted. The suggested standard speeds are:

11.3.1 *Strain-Controlled Tests*—A standard strain rate of 0.01 min^{-1} .

11.3.2 *Constant Head-Speed Tests*—A standard cross head displacement of 1.5 mm/min . [0.05 in./min].

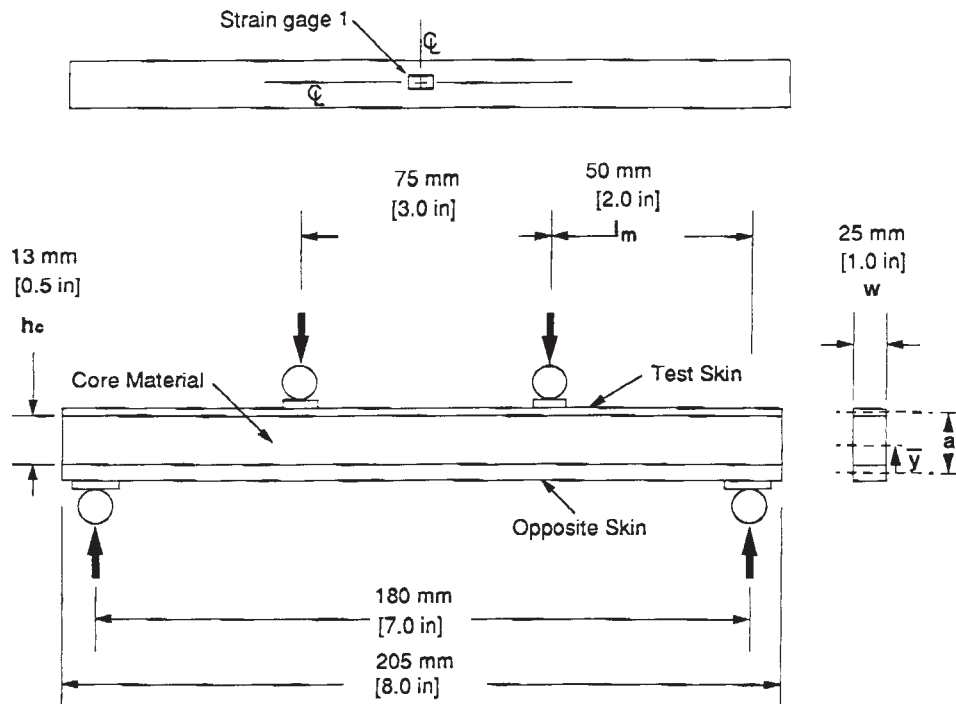

FIG. 2 Transverse (90°) Compression Sandwich Beam Test Specimen

11.4 *Test Environment*—Condition the specimen to the desired moisture profile and, if possible, test under the same conditioning fluid exposure level. However, cases such as elevated temperature testing of a moist specimen place unrealistic requirements on the capabilities of common testing machine environmental chambers. In such cases, testing at elevated temperature with no fluid exposure control may be necessary, and moisture loss during mechanical testing may occur. This loss can be minimized by reducing exposure time in the test chamber although care should be taken to ensure that the specimen temperature is at equilibrium. This loss may be further minimized by increasing the relative humidity in an uncontrolled chamber by hanging wet, coarse fabric inside the chamber, and keeping it moist with a drip bottle placed outside the chamber. In addition, fixtures may be preheated, temperature may be ramped up quickly, and hold time at temperature may be minimized before testing. Environmentally conditioned traveler coupons may be used to measure moisture loss during exposure to the test environment. Weigh a traveler coupon before testing and place it in the test chamber at the same time as the specimen. Remove the traveler coupon immediately after fracture and reweigh it to determine moisture loss. Record modifications to the test environment.

11.4.1 Store the specimen in the conditioned environment until test time, if the testing area environment is different than the conditioning environment.

11.4.2 Monitor test temperature by placing an appropriate thermocouple within 25 mm [1.0 in.] of the specimen gage section. Maintain temperature of the specimen, and the traveler coupon, if one is being used for thermal strain condition. Taping thermocouple(s) to the test specimen (and the traveler) is an effective measurement method.

11.5 *Fixture Installation*—Place the test fixture in the load machine.

11.6 *Specimen Insertion and Alignment*—Place the specimen into the test fixture and connect strain gages if used. Rubber pads may be used to distribute the load at the specimen/fixture contact points. Pads shall cover the full width of the beam, with a nominal length of 25 mm [1 in.] for the test facesheet and 38 mm [1.5 in.] for the opposite facesheet. Other pad materials may be used provided that local crushing failure of the test facesheet does not occur. The fixture shall be aligned so the longitudinal axis of the specimen is perpendicular to the longitudinal axes of the loading cylinders that are parallel to the plane of the specimen facesheet as shown in Figs. 1 and 2.

11.7 *Complete Transducer Installation*—Attach the strain-recording instrumentation to the strain gages on the specimen. Remove any remaining preload and zero the strain gages.

11.8 *Loading*—Load the specimen to failure at the cross-head speed specified in 11.2, recording load and strain from each gage continuously, if possible. An alternate method is to

record load and strain at regular intervals. If the strain values from gages No. 1 and 2 on a $[0]_{NT}$ sandwich specimen differ more than 10 % then the test results are not valid.

11.9 *Data Recording*—Record load versus strain (or displacement) continuously, or at frequent regular intervals. If a transition region or initial ply failures are noted, record the load, strain, and mode of damage at such points. If the specimen is to be failed, record the maximum load, the failure load, and the strain (or transducer displacement) at, or as near as possible to, the moment of failure.

11.10 *Failure Identification Codes*—Record the mode, area, and location of failure for each specimen. Choose a standard failure identification code based on the three-part code described in Test Method D 3410/D 3410M, and shown in Fig. 3. Examples of overall visual specimen failures and associated Failure Identification Codes (three acceptable and three unacceptable) are also shown in Fig. 3.

11.10.1 *Acceptable Failure Mode*—The objective of this test method is to load the sandwich beam in four point flexure and fail the upper (compressively loaded) facesheet in compression. Therefore, the acceptable failure modes for this test method are those that occur in the compressively loaded face and include one of the acceptable compression failure modes of Test Method D 3410/D 3410M. Unacceptable failure modes include core shear, core crushing, local wrinkling, or separation of the core from the facesheet.

11.10.2 *Acceptable Failure Area*—The acceptable failure area is within the central 50 mm [2 in.] of the gage section of the test facesheet.

12. Calculation

12.1 *Compressive Stress/Strength*—Calculate the ultimate compressive strength using Eq 1 and report the results to three significant digits. If the compressive modulus is to be calculated, determine the compressive stress at the required data points using Eq 2.

$$F^{cu} = \frac{P_m^{\max} \left(a - \bar{y} + \frac{h_f}{2} \right)}{2w \left[h_f (a - \bar{y})^2 + \frac{E_o}{E_f} h_o \bar{y}^2 \right]} \quad (1)$$

$$\sigma_i^c = \frac{P_i^c \left(a - \bar{y} + \frac{h_f}{2} \right)}{2w \left[h_f (a - \bar{y})^2 + \frac{E_o}{E_f} h_o \bar{y}^2 \right]} \quad (2)$$

where:

$$a = h_c + \frac{h_f}{2} + \frac{h_o}{2} \quad (3)$$

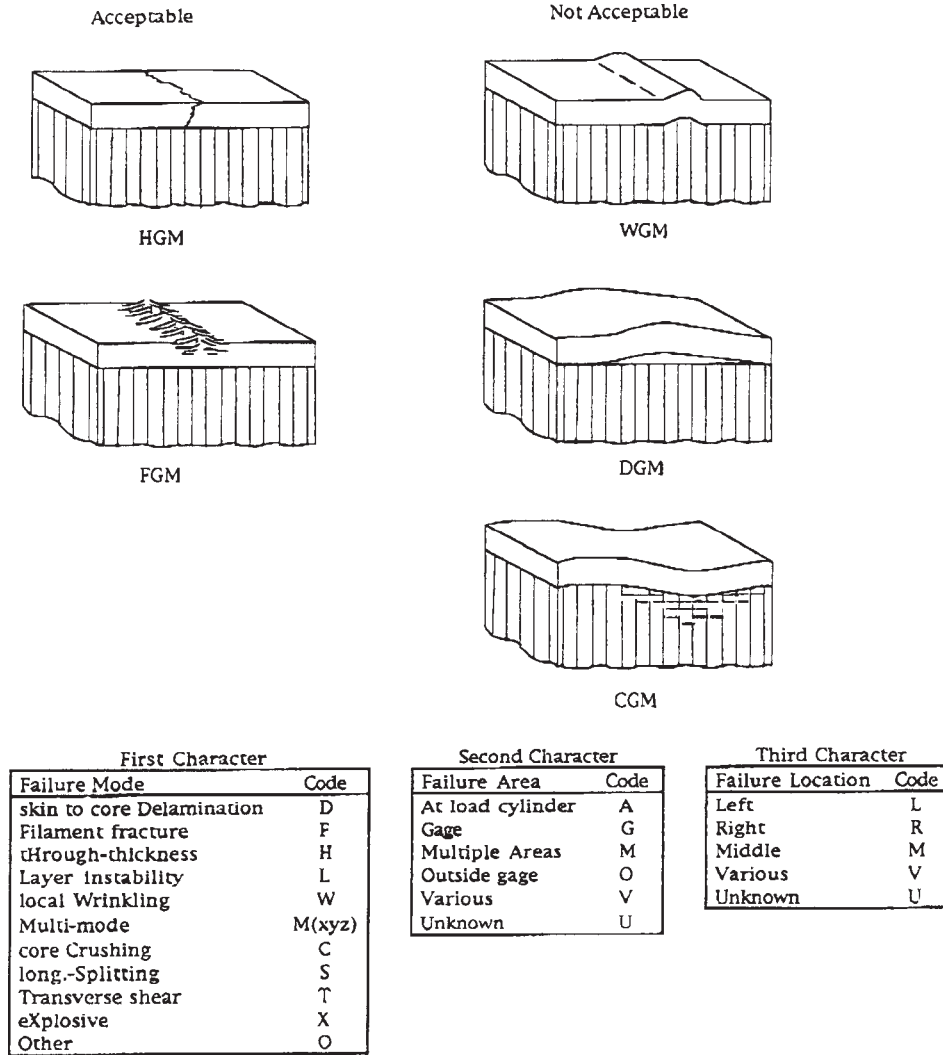

FIG. 3 Sandwich Beam Test Specimen Three Part Failure Identification Codes and Overall Specimen Failure Schematics

$$\bar{y} = \frac{a h_f}{h_f + \left[\frac{E_o}{E_f} \right] h_o} \quad (4)$$

and:

- a = distance between neutral axes of test and opposite facesheets, mm [in.];
- E_f = estimated modulus of elasticity of the test facesheet in the test direction, MPa [psi];
- E_o = modulus of elasticity of the opposite facesheet in the test direction, MPa [psi];
- F^{cu} = ultimate compressive strength, MPa [psi];
- h_c = thickness of core, mm [in.];
- h_f = thickness of composite test facing at test section, mm [in.];
- h_o = thickness of opposite facing, mm [in.];
- l_m = length of moment arm, mm [in.];
- P_i = load at i -th data point, MN [lbf];
- P^{max} = maximum load prior to failure, MN [lbf];
- w = width of composite test facing at test section, mm [in.];

- \bar{y} = distance to neutral axis of sandwich relative to neutral axis of the bottom facesheet, mm [in.]; and
- σ_i^c = compressive stress as the i th data point, MPa [psi].

For the specified [0] configuration, or whenever the test and opposite facesheets have the same stiffness and the opposite facesheet is twice the thickness of the test facesheet, Eq 1 and Eq 2 simplify to Eq 5 and Eq 6, respectively:

$$F^{cu} = \frac{P^{max} l_m \left(h_c + \frac{9}{4} h_f \right)}{2w h_f \left[h_c + \frac{3}{2} h_f \right]^2} \quad (5)$$

$$\sigma_i^c = \frac{P_i l_m \left(h_c + \frac{9}{4} h_f \right)}{2w h_f \left[h_c + \frac{3}{2} h_f \right]^2} \quad (6)$$

12.2 Compressive Strain and Ultimate Compression Strain—If compressive modulus or ultimate compressive strain is to be reported for a [0]_{NT} specimen, determine the average

compressive strain at each required data point using Eq 7 or Eq 8 and report the results to three significant figures. If compressive modulus or ultimate compressive strain is to be reported for a [90]_{NT} specimen, determine ϵ_i^c or ϵ^{cu} from the single strain gage on the specimen.

$$\epsilon_i^c = \frac{\epsilon_{1i} + \epsilon_{2i}}{2} \quad (7)$$

$$\epsilon^{cu} = \frac{\epsilon_1^{cu} + \epsilon_2^{cu}}{2} \quad (8)$$

where:

- ϵ_i^c = average compressive strain at *i*th data point, $\mu\epsilon$;
- ϵ_{1i} = gage-1 compressive strain at *i*th data point, $\mu\epsilon$;
- ϵ_{2i} = gage-2 compressive strain at *i*th data point, $\mu\epsilon$;
- ϵ^{cu} = average ultimate compressive strain, $\mu\epsilon$; and
- ϵ_2^{cu} = gage-2 ultimate compressive strain, $\mu\epsilon$.

12.3 Compressive Modulus of Elasticity:

12.3.1 Compressive Chord Modulus of Elasticity—Select the appropriate chord modulus strain range from Table 2. Calculate the compressive chord modulus of elasticity from the stress-strain data using Eq 9. If data are not available at the exact strain range end points (as often occurs with digital data), use the closest available data point. Report the compressive chord modulus of elasticity to three significant digits. Iteration(s) between Eq 2 and Eq 9 may be necessary to determine the compressive modulus to three significant digits, although following the recommendations listed in Table 1 yields stress levels that are relatively insensitive to the ratio of test facesheet modulus to opposite facesheet modulus. Also report the strain range used in the calculation. A graphical example of chord modulus is shown in Test Method D 3410/D 3410M.

12.3.1.1 The recommended strain ranges should only be used for material that do not exhibit a transition region (a significant change in the slope of the stress-strain curve) within the recommended strain range. If a transition region occurs within the recommended strain range, then a more suitable strain range should be used and reported.

$$E^{chord} = \Delta\sigma/\Delta\epsilon \quad (9)$$

where:

- E^{chord} = chord modulus of elasticity, MPa [psi];
- $\Delta\sigma$ = difference in applied compressive stress between the two strain points of Table 2, MPa [psi]; and
- $\Delta\epsilon$ = difference in the average compressive strain between the two strain points of Table 2 (use absolute strain not microstrain, nominally 0.002).

12.3.2 Compressive Modulus of Elasticity (Other Definitions)—Other definitions of elastic modulus may be evaluated and reported at the user's discretion. If such data are

TABLE 2 Specimen Alignment and Chord Modulus Calculation Strain Ranges

Chord Modulus Calculation Longitudinal Strain Range	
Start Point, $\mu\epsilon$	End Point, $\mu\epsilon$
1000 ^A	3000

^A This strain range was specified to represent the lower half of the stress/strain curve. For materials that fall below 6000 $\mu\epsilon$, a strain range of 25 to 50 % of ultimate is recommended.

generated and reported, report also the definitions used, the strain range used, and the results to three significant figures. Test Method E 111 provides additional guidance in the determination of modulus of elasticity.

NOTE 6—An example of another modulus definition is the secondary chord modulus of elasticity for materials that exhibit essentially bilinear stress-strain behavior. An example of secondary chord modulus is shown in Test Method D 3410/D 3410M.

12.4 Transition Strain—Where applicable, determine the transition strain from the bilinear longitudinal stress versus longitudinal strain curve. Create a best linear fit or chord line for each of the two linear regions and extend the lines until they intersect. Determine to three significant digits the longitudinal strain that corresponds to the intersection point and record this value as the transition strain. Report also the method of linear fit (if used) and the strain ranges over which the linear fit or chord lines were determined. A graphical example of transition strain is shown in Test Method D 3410/D 3410M.

12.5 Statistics—For each series of tests, calculate the average value, standard deviation, and coefficient of variation (in percent) for each property determined:

$$\bar{x} = \left(\sum_{i=1}^n x_i \right) / n \quad (10)$$

$$s_{n-1} = \sqrt{\left(\sum_{i=1}^n x_i^2 - n(\bar{x})^2 \right) / (n - 1)} \quad (11)$$

$$CV = 100 \times s_{n-1} / \bar{x} \quad (12)$$

where:

- \bar{x} = sample mean (average);
- s_{n-1} = sample standard deviation;
- CV = sample coefficient of variation, in percent;
- n = number of specimens; and
- x_i = measured or derived property.

13. Report

13.1 The information reported for this test method includes mechanical testing data, material identification data, and fiber, filler and core material identification data. This data shall be reported in accordance with Guide E 1434, Guide E 1309, and Guide E 1471, respectively. Each data item discussed is identified as belonging to one of the following categories: (VT) required for reporting of a valid test result, (VM) required for valid traceability, (RT) recommended for maximum test method traceability, (RM) recommended for maximum material traceability, or (O) for optional data items. The test lab is not responsible for reporting data items of which it does not have knowledge. The following information applies to the use of these documents for reporting data:

13.1.1 Guide E 1434:

13.1.1.1 The response for Field A5, Type of Test, is “Compression.”

13.1.1.2 Measured values will be reported for Fields F4 and F5. Nominal values are acceptable for Fields F7 through F9.

13.1.1.3 The failure identification code will be reported in Fields H18 and K50. The failure location is optional in Fields H17 and K49 since the failure identification code includes this information.

13.1.1.4 “Transition strain” is the progress damage parameter recorded in fields H26 and K54. Values of the transition strain are considered required for test validity in Fields H27, K55, and K56.

13.1.1.5 Statistical parameters for specimen dimensions, maximum load, maximum transverse strain, and bending strain are optional. These include Fields K1 through K9, K19 through K21, and K30 through K34. The testing summary sub-block is also optional (Fields K14 through K18).

13.1.2 *Guide E 1309*:

13.1.2.1 The consolidation method should be reported as the process stage type in Field E2.

13.1.2.2 The nominal cure cycle is required for valid material traceability in one set of process stage conditions in Field

E4. The actual cure cycle is recommended in a second set of process stage conditions in Field E4.

13.1.3 *Guide E 1471*:

13.1.3.1 “Tow or yarn filament count” and “Filament diameter” should be included as dimension parameters in Field B2.

14. Precision and Bias

14.1 *Precision*—The precision, defined as the degree of mutual agreement between individual measurements, cannot yet be estimated because of an insufficient amount of data. Round robin data are available in *ASTM STP 808 (2)*.

14.2 *Bias*—Bias cannot be determined for this test method as no acceptable reference standard exists.

15. Keywords

15.1 composite materials; compressive modulus of elasticity; compressive properties; compressive strength; sandwich beam

APPENDIX

(Nonmandatory Information)

X1. SIGNIFICANT POINTS OF MAJOR REVISIONS TO THIS TEST METHOD

X1.1 *1996–1997 Revisions*:

X1.1.1 Compressive stress/strength equations were modified to accommodate variations in test and opposite facesheet thickness, stiffness, and associated beam neutral axis shift.

X1.1.2 Transverse strain gage requirement was removed.

X1.1.3 Beam loading figure enhanced (cylinders, pads, skin thickness) and recommended dimensions for [90] configuration changed to allow use of less test material.

X1.1.4 Table 1 corrected for consistency with Test Method D 3410/D 3410M microstrain range for modulus calculation and bending checkpoint.

X1.1.5 Recommended dimensions table added.

X1.1.6 Failure mode sketches and identification codes clarified (see DoD/NASA Advanced Composites Design Guide Section 4.2.4).

X1.1.7 Symbols for skin and core thicknesses changed.

X1.1.8 Requirement for specimen alignment in fixture added.

X1.1.9 Boiler plate statements added for consistency with ASTM standards.

X1.1.10 Reference to six-ply prepreg removed as nominal facesheet thickness descriptor.

X1.1.11 Suggested approaches for environmental conditioning of traveler coupon noted.

X1.1.12 Added into interferences section that stress equations are based on beam theory.

ASTM International takes no position respecting the validity of any patent rights asserted in connection with any item mentioned in this standard. Users of this standard are expressly advised that determination of the validity of any such patent rights, and the risk of infringement of such rights, are entirely their own responsibility.

This standard is subject to revision at any time by the responsible technical committee and must be reviewed every five years and if not revised, either reapproved or withdrawn. Your comments are invited either for revision of this standard or for additional standards and should be addressed to ASTM International Headquarters. Your comments will receive careful consideration at a meeting of the responsible technical committee, which you may attend. If you feel that your comments have not received a fair hearing you should make your views known to the ASTM Committee on Standards, at the address shown below.

This standard is copyrighted by ASTM International, 100 Barr Harbor Drive, PO Box C700, West Conshohocken, PA 19428-2959, United States. Individual reprints (single or multiple copies) of this standard may be obtained by contacting ASTM at the above address or at 610-832-9585 (phone), 610-832-9555 (fax), or service@astm.org (e-mail); or through the ASTM website (www.astm.org).