



Designation: E 1234 – 95<sup>ε01</sup>

## Standard Practice for Handling, Transporting, and Installing Nonvolatile Residue (NVR) Sample Plates Used in Environmentally Controlled Areas for Spacecraft<sup>1</sup>

This standard is issued under the fixed designation E 1234; the number immediately following the designation indicates the year of original adoption or, in the case of revision, the year of last revision. A number in parentheses indicates the year of last reapproval. A superscript epsilon (ε) indicates an editorial change since the last revision or reapproval.

---

<sup>ε1</sup> NOTE ~~To bring Subcommittee E21.05's existing standards into compliance with Part H of ASTM's Form and Style Manual, the M designation has been editorially removed in July 2000.~~

---

### 1. Scope

1.1 This practice covers the handling, transporting, and installing of sample plates used for the gravimetric determination of nonvolatile residue (NVR) within and between facilities.

1.2 The values stated in SI units are to be regarded as the standard.

1.3 *This standard does not purport to address all of the safety concerns, if any, associated with its use. It is the responsibility of the user of this standard to establish appropriate safety and health practices and determine the applicability of regulatory limitations prior to use.*

### 2. Referenced Documents

2.1 *ASTM Standards:*

---

<sup>1</sup> This practice is under the jurisdiction of ASTM Committee E-21 on Space Simulation and Applications of Space Technology and is the responsibility of Subcommittee E21.05 on Contamination.

Current edition approved Aug. 15, 1995; May 10, 2001. Published October 1995; July 2001. Originally published as E 1234 – 88. Last previous edition E 1234 – 88 (1993); E 1234 – 95<sup>ε1</sup>.

E 1235 Test Method for Gravimetric Determination of Nonvolatile Residue (NVR) in Environmentally Controlled Areas for Spacecraft<sup>2</sup>

F 50 Practice for Continuous Sizing and Counting of Airborne Particles in Dust-Controlled Areas and Cleanrooms Using Instruments Capable of Detecting Single Sub-Micrometre and Larger Particles<sup>2</sup>

2.2 ~~U.S. Federal Standard~~: ISO Standards:

~~14644-1, Cleanrooms and Associated Controlled Environments—Part 1: Classification of Air Cleanliness<sup>3</sup>~~

~~FED-STD-209 Airborne Particulate~~

~~14644-2, Cleanrooms and Associated Controlled Environments—Part 2: Specifications for Testing and Monitoring to Prove Continued Compliance with ISO 14644-1<sup>3</sup>~~

~~14644-5, Cleanrooms and Associated Controlled Environments—Part 5: Operations<sup>3</sup>~~

~~14951-3, Space Systems—Fluid Characteristics—Part 3: Nitrogen<sup>4</sup>~~

~~14952-3, Space Systems—Surface Cleanliness Classes in Cleanrooms of Fluid Systems—Part 3: Analytical Procedures for the Determination of Nonvolatile Residue and Clean Zones: Particulate Contamination<sup>4</sup>~~

2.3 ~~U.S. Department of Defense Standards~~:<sup>3</sup>

~~MIL-F-51068F Filters, Federal Standard:~~

~~FED-STD-209E Airborne Particulate (High-Efficiency Fire Resistant)~~

~~Air Force TO 00-25-203, 1 Dec. 1972, Change 15, 24 Oct. 1992, Contamination Control of Aerospace Facilities, U.S. Air Force.~~

~~MIL-STD-1246 Product Cleanliness Levels Classes in Cleanrooms and Contamination Control Program: Clean Zones<sup>5</sup>~~

2.4 ~~Institute of Environmental Sciences~~:<sup>4</sup>

<sup>2</sup> Annual Book of ASTM Standards, Vol 15.03.

<sup>3</sup> Available from Standardization Documents Order Desk, Bldg. 4 Section D, 700 Robbins Ave., Philadelphia, PA, 19111-5094, Attn.: NPODS. Institute of Environmental Sciences and Technology, 940 E. Northwest Highway, Mount Prospect, IL 60056.

<sup>4</sup> Available from the American Institute of Environmental Sciences, 940 E. Northwest Highway, Mount Prospect, IL 60056. Aeronautics & Astronautics, 1801 Alexander Bell Drive, Suite 500, Reston, VA 20191-4344.

<sup>5</sup> Available from American Society Institute of Mechanical Engineers, United Engineering Center, 345 Environmental Sciences and Technology, 940 E. 47th St., New York, NY 10017; Northwest Highway, Mount Prospect, IL 60056, and U.S. government sources.

IES-RP-CC001.3 HEPA Sciences and Technology:  
 IEST-RP-CC001.3, HEPA and ULPA Filters<sup>3</sup>  
 IEST-RP-CC006.2, Testing Cleanrooms<sup>3</sup>  
 IEST-RP-CC007.1, Testing ULPA Filters<sup>3</sup>  
 IEST-RP-CC016, The Rate of Deposition of Nonvolatile Residue in Cleanrooms<sup>3</sup>  
 IEST-RP-CC034.1, HEPA and ULPA Filter Leak Tests<sup>3</sup>  
 IEST-STD-CC1246, Product Cleanliness Levels and Contamination Control Program<sup>3</sup>  
 2.5 American National Standards Institute:  
 ANSI/ASME B46.1-1985, Surface Texture (Surface Roughness, Waviness, and Lay)<sup>6</sup>

### 3. Terminology

#### 3.1 Definitions:

3.1.1 ~~air cleanliness class~~ ISO Class N (airborne particulate cleanliness class), *n*—~~the level~~ level of cleanliness specified by airborne particulate concentrations as defined in ISO 14644-1 and 14644-2, where  $10^N$  is the maximum allowable ~~concentration~~ concentration (particles per cubic meter ~~(e)~~).

3.1.1.1 ~~Discussion~~—The considered particle sizes (lower threshold values) applicable for classification with ISO 14644-1 are limited to the range from 0.1 through 5 μm. Particles larger than 5 μm (macroparticles) may be expressed in FED-STD-209E accordance with Annex E of ISO 14644-1.

3.1.2 ~~FS209, n~~—the level of cleanliness specified by the maximum allowable number of particles per cubic foot of air as defined in FED-STD-209E.

3.1.2.1 ~~Discussion~~—This is provided for information and to facilitate the transition to the use of the ISO classification standard (ISO 14644-1).

3.1.3 ~~clean area, n~~—a general term that includes cleanrooms, controlled areas, good housekeeping areas, and other areas that have contamination control by physical design and specified operating procedures.

3.1.34 ~~clean zone, n~~—a defined space in which the contamination is controlled to meet specified cleanliness levels.

3.1.45 ~~contaminant, n~~—unwanted molecular and particulate matter that could affect or degrade the performance of the components upon which they reside.

3.1.56 ~~contamination, n~~—a process of contaminating.

3.1.67 ~~controlled area, n~~—an environmentally controlled area, operated as a cleanroom, but without the final stage of HEPA (or better) filters used in cleanrooms.

3.1.67.1 ~~Discussion~~—Only rough filters (50 to 60 % efficiency) and medium efficiency filters (80 to 85 % efficiency) are required for a controlled area. (See Air Force T.O. 00-25-203.) The maximum allowable airborne particle concentrations are ISO Class M7 8.5 (FS209 Class 283 000) area for particles  $\geq 0.5 \mu\text{m}$  and ISO Class M6.5 (100 000) 8 (FS209 Class 100 000) for particles  $\geq 5.0 \mu\text{m}$ .

3.1.78 ~~environmentally controlled areas, n~~—cleanrooms, controlled areas, good housekeeping areas, and other enclosures that are designed to protect products from contamination.

3.1.78.1 ~~Discussion~~—Cleanliness is achieved by controlling air purity, temperature, humidity, materials, garments, and personnel activities.

3.1.89 ~~facility (clean facility), n~~—the total real property required to accomplish the cleanroom functions.

3.1.910 ~~good housekeeping area, n~~—an environmentally controlled area without quantitative cleanliness requirements but maintained in a visibly clean condition.

3.1.910.1 ~~Discussion~~—Office, laboratory, and storage areas with air conditioning and janitorial service are typical of good housekeeping areas.

3.1.101 ~~HEPA (high efficiency particulate air) filter, n~~—a filter for air with a removal efficiency in excess of 99.97 % for 0.3-μm sized particles.

3.1.101.1 ~~Discussion~~—For this application, HEPA filters shall meet the requirements of MIL-F-51068F IEST-RP-CC001.3, IEST-RP-CC007.1, IEST-RP-CC034.1, and paragraph 6.8 of this practice.

3.1.142 ~~molecular contaminant—nonparticulate contaminant, n~~—nonparticulate matter.

3.1.142.1 ~~Discussion~~—The molecular contaminant may be in a gaseous, liquid, or solid state. It may be uniformly or nonuniformly distributed; or be in the form of droplets. Molecular contaminants account for most of the NVR.

3.1.123 ~~NVR (nonvolatile residue), n~~—quantity of residual soluble, suspended, and particulate matter remaining after the controlled evaporation of a volatile liquid at a specified temperature.

3.1.123.1 ~~Discussion~~—The liquid is usually filtered through a membrane filter, of a specified size, before evaporation. The process used to determine the NVR may affect the quantitative measurement. Process factors include filter size, solvent, and the evaporation temperature and atmosphere. For this reason, the process must be defined.

<sup>6</sup> ~~Nylon 6 (heat sealable Capran 980~~

<sup>6</sup> Available from Allied Chemical) has been found to be satisfactory. American Society of Mechanical Engineers, United Engineering Center, 345 E. 47th St., New York, NY 10017.

3.1.134 *particle (particulate contaminant), n*—a piece of matter in a solid or liquid (droplet) state with observable length, width, and thickness. The size of a particle is usually defined by its greatest dimension and is specified in micrometres.

#### 4. Summary of Practice

4.1 Covered, stainless steel, NVR plates are transported in a sealed carrier within an outer nylon bag to the facility that is to be monitored for NVR deposition.

4.2 The outer bag is removed from the plate carrier within the entrance air lock of the cleanroom, controlled area, or other environmentally controlled area in accordance with the operational procedures for that facility and associated clean areas.

4.3 The clean NVR plate carrier is taken into the clean area.

4.4 Locations for attaching the plates within the clean area are in accordance with the facility contamination control plan, operating procedures, and other official documentation.

4.5 Each NVR plate is removed from the carrier, the cover is removed, and the plate is mounted in a vertical position within the clean area.

4.6 The cover is returned to the plate carrier for storage until required when the plates are collected after the required exposure time.

4.7 One of the NVR plates is removed from the carrier, the cover is removed, the cover is replaced, and the plate is returned to the carrier. This NVR plate is handled in the same manner as the exposed plates. This plate is designated as the blank or control sample.

4.8 After exposure, the NVR plates are removed from their locations in the clean area and are replaced with clean NVR plates in accordance with the facility and clean area contamination control plan, operating procedures, and other official documents.

4.9 The exposed plates are covered and placed into the original NVR plate carrier, returned to the analysis laboratory, and processed in accordance with Test Method E 1235.

#### 5. Apparatus and Materials

5.1 *NVR Plate*, Type 316 corrosion-resistant steel with an area of approximately 0.1 m<sup>2</sup> (1 ft<sup>2</sup>). The plate shown in Fig. 1 has been found to be satisfactory. The surface texture of the sampling surface shall be 0.80 μm (32 μin.) or better per ANSI/ASME B46.1. The plate shall be electropolished and engraved with an identification number.

5.2 *NVR Plate Cover*, Type 316 corrosion-resistant steel. The cover shown in Fig. 2 has been found to be satisfactory. The surface texture shall be 0.80 μm (32 μin.) or better per ANSI/ASME B46.1.

5.3 *Noncontaminating Nylon (Polyamide) Bag* to enclose each covered NVR plate.<sup>7</sup>

5.3.1 Bags shall meet the safety and outgassing requirements for the spacecraft and spacecraft processing facility and shall not contain or generate molecular or particulate matter that could contaminate the NVR plate or NVR plate carrier.

5.4 *NVR Plate Carrier*—The sealable, aluminum carrier shown in Fig. 3 has been found to be satisfactory. The carrier shall be constructed so as to prevent cross contamination between plates.

5.5 *Noncontaminating Nylon (Polyamide) Bag*<sup>6</sup>, to protect the NVR plate carrier in ~~5.4 nylon~~ 5.4. The polyamide film material shall meet the safety and outgassing requirements for the spacecraft and spacecraft processing facility. (See Note 2.)

5.6 *HEPA filtered, ISO Class M 3.5 (Class 5 (FS209 Class 100))*, or better environment, as defined in ~~FED-STD-209, ISO 14644-1~~, unidirectional air flow, clean work station.

5.7 *Gloves*, solvent compatible and resistant.<sup>7</sup> **(Warning—**Gloves shall be used to protect the hands from accidental spills of the NVR solvent and minimize contamination of exposed samples. Gloves shall be selected to meet local safety and contamination control requirements.)

5.8 *Oil-Free Aluminum Foil*,<sup>10</sup> to cover the NVR plate if the cover in 6.2 is not used.

5.9 *HEPA Filters*—All HEPA filters shall be constructed of low outgassing, corrosion-resistant, and fire-resistant materials such as Grade 1 in ~~IES-RP-CC001.3 and MIL-F-51068F~~. Types HA and HD, MIL-F-51068F, IES-RP-CC001.3. Filters with stainless steel or aluminum frames; should be considered. The filters shall not be tested with DOP (dioctylphthalate) or other liquid aerosols. Ambient air and solid aerosol test methods are acceptable alternatives to the DOP test. Applicable test methods from IEST-RP-CC007.1 and IEST-RP-CC034.1 shall be considered.

#### 6. Procedure

6.1 Clean and prepare the NVR sample plates and plate covers in accordance with Cleaning of Equipment (8.2) of Test Method E 1235.

6.2 Verify that the carrier is visually clean. If cleaning is required, clean to Level 100A per ~~M IEST-STD-CC1246~~.

6.3 Perform all packaging operations in a unidirectional air flow; in clean work station ~~ISO Class M 3.5 (FS209 Class 100)~~ environment as defined in ~~FED-STD-209~~ ISO 14644-1 or an equivalent cleanroom or clean zone.

6.4 Verify that the NVR plate cover (5.2) is on the NVR plate or that the oil-free aluminum foil (5.8) is installed.

<sup>7</sup>Pioneer green nitrile gloves, Catalog No. A10-1, have

<sup>7</sup> Heat-sealable Capran 980 from Allied Chemical has been found to be satisfactory.

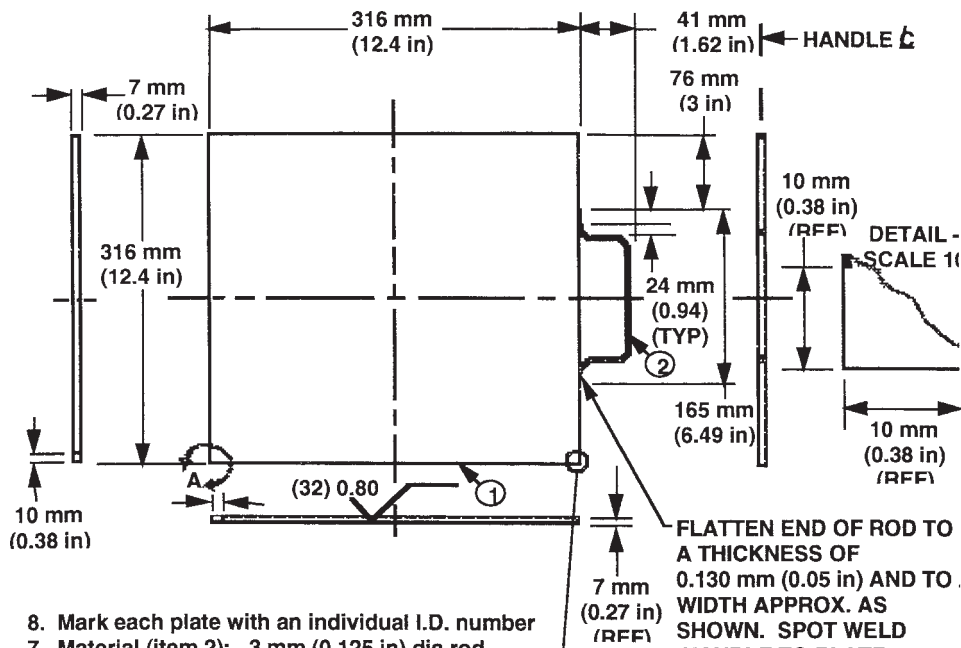

- 8. Mark each plate with an individual I.D. number
  - 7. Material (item 2): 3 mm (0.125 in) dia rod type 316 cor res steel
  - 6. Material (item 1): 0.51 mm (0.020 in) sheet type 316 cor res steel
  - 5. Break all sharp edges
  - 4. Handle bend radii: 8 mm (0.3 in)
  - 3. Bend radii are optional on plate
  - 2. Electropolish after fabrication
  - 1. Surface texture on active surface: 0.80 μm (32 μin) max per ANSI B46.1. Finish on all other surfaces must be smooth & free of all tool marks
- FLATTEN END OF ROD TO A THICKNESS OF 0.130 mm (0.05 in) AND TO A WIDTH APPROX. AS SHOWN. SPOT WELD HANDLE TO PLATE 3 PLACES EQUALLY SPACED. TYP EACH END.**
- ALL CORNERS MUST BE CLOSED (FREE OF CRACKS & HOLES) EXCEPT FOR LOWER L.H. CORNER WHICH IS OPEN TO BOTTOM AS SHOWN**
- FI-B46G. 1. Finish NVR. Con all other surfaces must be smooth and free of a PII tool marks**
- 2. Electropolish after fabrication
  - 3. Bend radii are optional on plate
  - 4. Handle bend radii: 8 mm (0.3 in.)
  - 5. Break all sharp edges
  - 6. Material (Item 1): 0.51-mm (0.020-in.) sheet type 316 cor res steel
  - 7. Material (Item 2): 3-mm (0.125-in.) dia rod type 316 cor res steel
  - 8. Mark each plate with an individual I.D. number

6.5 Verify that a certification decal or tag (See Fig. 4) is included with each NVR plate.

NOTE 1—Care should be taken not to touch the sampling surfaces of the NVR plate. Gloves should be worn to prevent skin flakes and oil from contaminating the plates.

6.6 Verify that the serial numbers of the NVR plates, plate covers, and carrier are on the traveler paper (see Fig. 5).

6.7 Verify that the covered NVR plate is enclosed in a noncontaminating nylon bag (6.14) (5.3) and installed in the NVR plate carrier. Place the lid on the carrier and fasten securely.

6.8 Affix the proper quality decal or tag (see Fig. 4) to the container in accordance with local requirements.

6.9 Seal the NVR plate carrier in the noncontaminating bag.

6.10 Attach the traveler sheets (Fig. 5) to the outer bag.

6.11 Transport the NVR plate carrier in a closed vehicle to the clean facility.

NOTE 2—The objective is to protect the carrier from contamination during transport. The noncontaminating nylon (polyamide) bag shall be used when the carrier is to be removed from a controlled environment for transport.

NOTE 3—NVR plates inside secured plate carriers are to be transported within a moderately controlled area, for example, inside the cab of the truck, as to limit exposure to contamination and excessive changes in temperature. Plates returning to the laboratory for analysis are particularly critical because of possible volatility of the NVR.

<sup>9</sup> Fed Spec. Food Service Grade aluminum foil, oil free, Federal Stock

<sup>9</sup> Pioneer green nitrile gloves, Catalog No. 8135-00-724-0551 has A10-1, have been found to be satisfactory.

<sup>10</sup> Fed Spec. Food Service Grade aluminum foil, oil free, Federal Stock No. 8135-00-724-0551 has been found to be satisfactory.

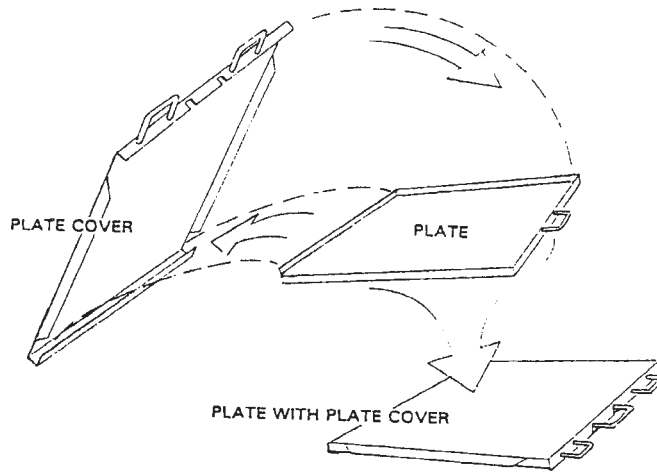

FIG. 2 NVR Plate Cover

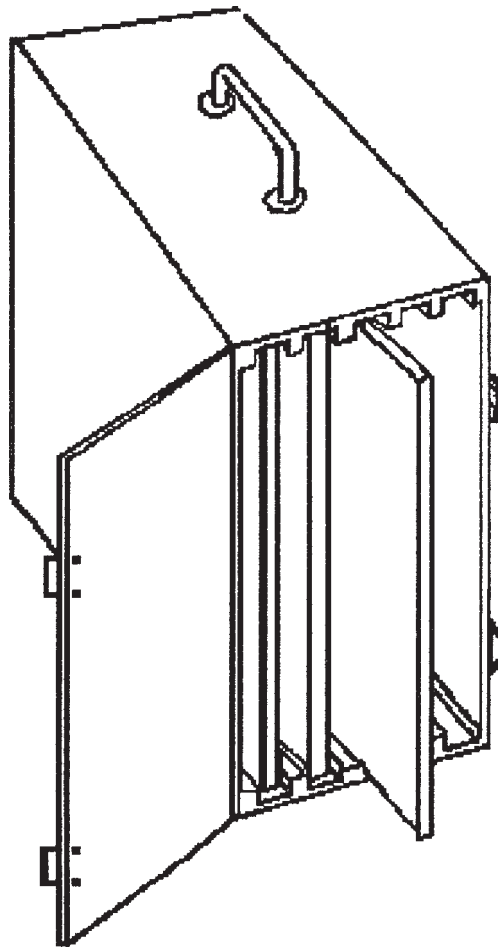

FIG. 3 NVR Plate Carrier

6.12 If the NVR plate carrier is not to be used immediately, store it within an outer nylon (polyamide) bag in an ISO Class-M7 8.5 (FS209 Class 283 000) or better clean area, a controlled area, or a good housekeeping area. Reclean the plates in accordance with Test Method E 1235, Cleaning of Equipment (68.2), after six months for acceptability or as determined by local conditions.

NOTE 4—An acceptable storage time for the NVR plates before requiring recertification should be determined because local conditions can affect the process.

6.13 Remove the outer bag in the entrance air lock of the cleanroom, controlled area, or other environmentally controlled area in accordance with the procedures of the clean areas for handling clean tools and instruments.

CERTIFIED FOR SAMPLING	
Inspector:	Date:
LAB W.O. No.:	Date Sampled
Measurement: NVR	Quantity: (1) mg/
Item: (2)	Serial No.:

NOTE 1—(1) The quantity of NVR can be “mg/L,” “mg/0.1 m<sup>2</sup>,” and so forth. (2) The item can be “NVR plate,” “plate carrier,” “NVR solvent,” and so forth.

**FIG. 4 Typical Certification Tag**

- 6.14 Clean the outside of the NVR plate carrier, if required, in accordance with clean area procedures.
  - 6.15 Personnel shall wear the cleanroom garments prescribed for the clean area.
  - 6.16 Carry the NVR plate carrier into the clean area.
  - 6.17 Determine the mounting locations for the NVR plates. The locations are usually dictated by the contamination control plan and operating procedures for the clean area.
  - 6.18 Open the NVR plate carrier and remove the NVR plates one at a time.
  - 6.19 Put on gloves before handling the NVR plates.
  - 6.20 Remove the plate from the plastic bag.
  - 6.21 Remove the cover and store the cover in the carrier for use after the required exposure.
  - 6.22 If aluminum foil was used to cover the plates instead of hard covers, carefully remove the foil from each plate without touching the sampling surfaces. Carefully store each foil for use after the required exposure. Discard the aluminum foil if it is contaminated or damaged and replace with a clean foil.
  - 6.23 Mount the plates mechanically in the predetermined location in a vertical position.
- NOTE 5—~~If aluminum foil was used to cover the plates instead of hard covers, carefully remove the foil from each plate without touching the sampling surfaces. Carefully store each foil for use after the required exposure. Discard the aluminum foil if it is contaminated or damaged and replace with a clean foil.~~
- ~~6.22 Mount the plates mechanically in the predetermined location in a~~ 5—The vertical position.
- NOTE 6—~~The vertical position is specified so as to minimize the deposition of large particles that can contain molecular matter that could cause an erroneous NVR upon contact with the NVR solvent.~~
- 6.234 Record the serial numbers, locations, and sample numbers for each sample plate. Transfer the information to the traveler sheet or work sheet and requester log book.
  - 6.245 The requester shall maintain a log book of all plate installations.
  - 6.256 Remove at least one sample plate, remove the cover, replace the cover, and return the plate immediately to the NVR plate carrier for use as a blank or control sample.
  - 6.267 Securely fasten the lid of the NVR plate carrier.
  - 6.278 Store the closed NVR plate carrier within the clean area during the exposure period.
  - 6.289 The exposure is usually for no less than one week and could be four weeks (one month) or longer. The exposure is determined by the contamination control plan and procedures for the clean area and special procedures for the operation.
  - 6.2930 Open the NVR plate carrier immediately before removing the exposed NVR plates from their mounts. Handle the container lid with care so as not to contaminate the interior surface.
  - 6.301 Remove the exposed NVR plates from their mounts, one at a time, cover, bag, and return to the original NVR plate carrier.
  - 6.312 Securely fasten the lid of the plate carrier.
  - 6.323 Record the exposure times and any other appropriate comments on the traveler sheet.
  - 6.334 Seal the NVR plate carrier in the approved, noncontaminating bag in accordance with clean area hardware removal procedures.
  - 6.345 If required, install the clean NVR plates to replace the exposed plates by following the preceding procedures.
  - 6.356 Transport the enclosed NVR plate carrier directly to the analytical laboratory in a closed vehicle. Do not exceed the maximum time for transport which is 60 min.
  - 6.367 The receiver at the analytical laboratory shall sign, date, and record the time. One copy of the traveler shall be retained by the organization responsible for the retrieval and delivery of the sample plate.
  - 6.378 Process the NVR plates as quickly as possible in accordance with the requester’s requirements.
  - 6.389 If required, store the bagged NVR plate carrier in an ISO Class-M7 8.5 (FS209 Class 283 000), or better, a controlled area, or a good housekeeping area.
  - 6.3940 Remove the outer bag or container immediately before placing it in a clean work station.
  - 6.401 Analysis shall be in accordance with Test Method E 1235.

1. \_\_\_\_\_  
Sample No.
Plate S/N
Carrier S/N

2. **INSTALLATION**  
 by \_\_\_\_\_ Requester \_\_\_\_\_  
Print Name
Print Name  
 \_\_\_\_\_  
Signature
Signature  
 \_\_\_\_\_  
Location
Day
Mo.
Yr.
Time

**Comments**  
 \_\_\_\_\_  
 \_\_\_\_\_  
 \_\_\_\_\_

3. **RETRIEVAL**  
 by \_\_\_\_\_ Requester \_\_\_\_\_  
Print Name
Print Name  
 \_\_\_\_\_  
Signature
Signature  
 \_\_\_\_\_  
Location
Day
Mo.
Yr.
Time

**Comments**  
 \_\_\_\_\_  
 \_\_\_\_\_  
 \_\_\_\_\_

4. **DELIVERY TO ANALYTICAL LABORATORY**  
 by \_\_\_\_\_ Requester \_\_\_\_\_  
Print Name
Print Name  
 \_\_\_\_\_  
Signature
Signature  
 \_\_\_\_\_  
Day
Mo.
Yr.
Time

**Comments**  
 \_\_\_\_\_  
 \_\_\_\_\_  
 \_\_\_\_\_

**One copy to agency responsible for installation, retrieval, and transport, one copy to analytical laboratory, and one copy to requester with the laboratory report.**

FIG. 5 NVR Sample Plate Traveler

6.4H2 Return one copy of the traveler to the requester along with the laboratory report (see Figs. 8, Figs. 9, and Figs. 10 8–10 in Test Method E 1235).

**7. Keywords**

7.1 cleanroom; NVR; nonvolatile residue; witness surface

*ASTM International takes no position respecting the validity of any patent rights asserted in connection with any item mentioned in this standard. Users of this standard are expressly advised that determination of the validity of any such patent rights, and the risk of infringement of such rights, are entirely their own responsibility.*

*This standard is subject to revision at any time by the responsible technical committee and must be reviewed every five years and if not revised, either reapproved or withdrawn. Your comments are invited either for revision of this standard or for additional standards and should be addressed to ASTM International Headquarters. Your comments will receive careful consideration at a meeting of the responsible technical committee, which you may attend. If you feel that your comments have not received a fair hearing you should make your views known to the ASTM Committee on Standards, at the address shown below.*

*This standard is copyrighted by ASTM International, 100 Barr Harbor Drive, PO Box C700, West Conshohocken, PA 19428-2959, United States. Individual reprints (single or multiple copies) of this standard may be obtained by contacting ASTM at the above address or at 610-832-9585 (phone), 610-832-9555 (fax), or [service@astm.org](mailto:service@astm.org) (e-mail); or through the ASTM website ([www.astm.org](http://www.astm.org)).*