



Designation: **F 2111 – 01a**

## **Standard Practice for Measuring Intergranular Attack or End Grain Pitting on Metals Caused by Aircraft Chemical Processes<sup>1</sup>**

This standard is issued under the fixed designation F 2111; the number immediately following the designation indicates the year of original adoption or, in the case of revision, the year of last revision. A number in parentheses indicates the year of last reapproval. A superscript epsilon (ε) indicates an editorial change since the last revision or reapproval.

### **1. Scope**

1.1 This practice covers the procedures for testing and measuring intergranular attack (IGA) and end grain pitting on aircraft metals and alloys caused by maintenance or production chemicals.

1.2 The standard does not purport to address all qualification testing parameters, methods, critical testing, or criteria for aircraft production or maintenance chemical qualifications. Specific requirements and acceptance testing along with associated acceptance criteria ~~may~~ shall be found where applicable in procurement specifications, materials specifications, ~~or~~ appropriate process specifications, or previously agreed upon specifications.

1.3 *This standard does not purport to address all of the safety concerns, if any, associated with its use. It is the responsibility of the user of this standard to establish appropriate safety and health practices and determine the applicability of regulatory limitations prior to use.*

### **2. Referenced Documents**

2.1 *ASTM Standards:*

E 3 Practice for Preparation of Metallographic Specimens<sup>2</sup>

---

<sup>1</sup> This practice is under the jurisdiction of ASTM Committee F07 on Aerospace and Aircraft and is the direct responsibility of Subcommittee F07.07 on Qualification Testing of Aircraft Cleaning Materials.

Current edition approved ~~May~~ Nov. 10, 2001. Published January 2002. Originally published as F 2111 - 01. Last previous edition F 2111 - 01.

G 1 Practice for Preparing, Cleaning, and Evaluating Corrosion Test Specimens<sup>3</sup>

G 15 Terminology Relating to Corrosion and Corrosion Testing<sup>3</sup>

G 46 Guide for Examination and Evaluation of Pitting Corrosion<sup>3</sup>

2.2 *ASME Standard*:

B46.1 Surface Texture (Surface Roughness, Waviness, and Lay)<sup>4</sup>

### 3. Terminology

3.1 *Definitions of Terms Specific to This Standard*:

3.1.1 *long transverse (LT)*—the longest dimension perpendicular to the rolling or extruded direction of the extrusion in the original shape.

3.1.2 *pit*—a depression or cavity with a width to depth ratio of <6 to 1.

3.1.3 *short transverse (ST)*—the shortest dimension perpendicular to the rolling or extruded direction of the extrusion in the original shape.

3.1.4 *surface roughness ( $R_a$ )*—filtered mean line  $\mu\text{in.}$  ( $\mu\text{m}$ ) as defined in ASME B46.1, Surface Texture.

### 4. Significance and Use

4.1 If not properly qualified, chemicals and chemical processes can attack metals used during aircraft maintenance and production. It is important to qualify only processes and chemical formulas that do not have any deleterious effects on aircraft metallic skins, fittings, components, and structures. This test procedure is used to detect and measure intergranular attack or pitting depth caused by aircraft maintenance chemical processes, hence, this test procedure is useful in selecting a process that will not cause intergranular attack or end grain pitting on aircraft alloys.

4.2 The purpose of this practice is to aid in the qualification or process conformance testing or production ~~or~~ of maintenance chemicals for use on aircraft.

4.2.1 Actual aircraft processes in the production environment shall give the most representative results; however, the test results cannot be completely evaluated with respect to ambient conditions which normally vary from day to day. Additionally, when testing chemicals requiring dilutions, water quality and composition can play a role in the corrosion rates and mechanism affecting the results.

4.2.2 Some examples of maintenance and production chemicals include: organic solvents, paint strippers, cleaners, deoxidizers, water-based or semi-aqueous cleaners, or etching solutions and chemical milling solutions.

### 5. Apparatus and Materials

5.1 *Metallurgical Microscope*, capable of 500 $\times$  or greater magnification with scaled filar units in microscope eyepiece.

5.2 *Metallurgical Polishing Wheel*, capable of polishing test specimen to a surface finish of 5- $\mu\text{in.}$   $R_a$  or finer.

5.3 *Noncorrosive Metallurgical Quality Polishing Media or Compound*, capable of polishing test specimens to 5- $\mu\text{in.}$   $R_a$  or finer.

### 6. Test Specimens

6.1 Unless otherwise specified, manufacture test specimens as follows:

6.1.1 Prepare at least one test specimen (or more when specified by applicable process specification) from plate, sheet, extrusion, or hand forging as illustrated in Fig. 1.

6.1.2 Cut out metallurgical test specimen and polish Face A to 0.812  $\mu\text{m}$  (32  $\mu\text{in.}$ )  $R_a$  or preferably finer with polish as given in 5.3.

### 7. Procedure

7.1 Expose entire polished specimen through normal production or maintenance cycle. Use test temperatures and periods of time representative of the highest usage temperature and longest exposure times associated with the chemical process. For conformance testing, process specimens with representative-like alloy parts through all operations including precleaning, post rinsing, and so forth, for the time necessary to remove the amount of metal specified by process or to achieve process specified cleanliness.

7.2 For chemicals normally used at room temperature for periods of less than 8 h, use 40.6°C (105°F)  $\pm$  1°C (1.8°F) for an exposure time of 24 h.

7.2.1 A range of conditions shall be used over which the process is expected to operate. For example, if the process will be used from 10°C (50°F) to 37.8°C (100°F), data points shall be generated from 10°C (50°F) to 37.8°C (100°F) for completeness.

7.3 If required, clean specimen by removing corrosion products in accordance with Practice G 1. An ideal procedure should remove only corrosion products and not result in the removal of any base metal.

<sup>2</sup> *Annual Book of ASTM Standards*, Vol 03.01.

<sup>3</sup> *Annual Book of ASTM Standards*, Vol 03.02.

<sup>4</sup> Available from American Society of Mechanical Engineers, Headquarters, Three Park Ave., New York, NY 10016-5990.

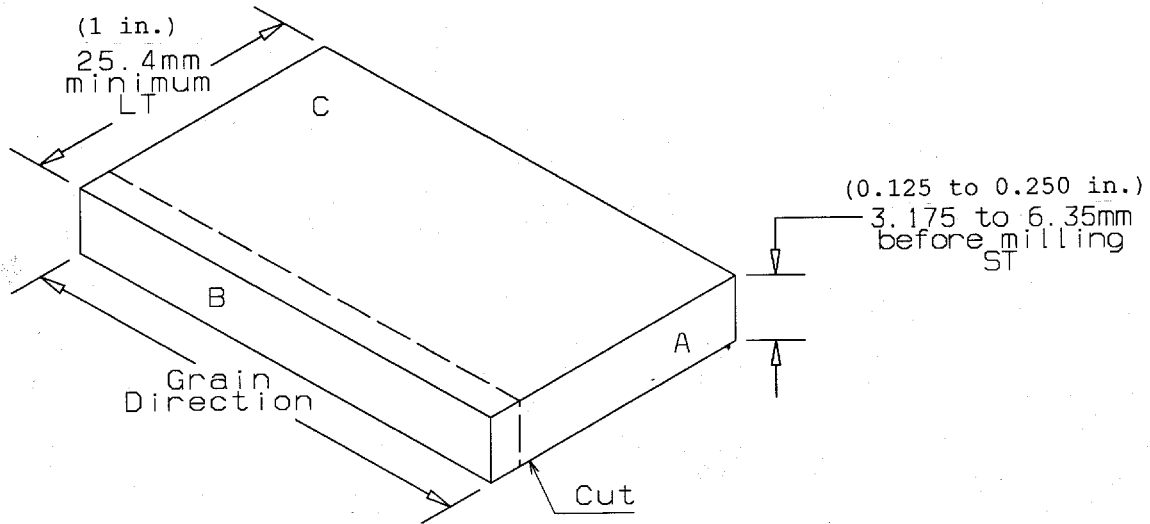

Face A is polished to  $.812 \mu\text{m}$  ( $32 \mu\text{in.}$ )  $R_a$  or finer

FIG. 1 Face A

7.4 After exposing the test specimens to the required times and temperatures, clean and mount metallurgical test specimen as illustrated in Fig. 2 in accordance with Practice E 3.

7.5 After mounting, metallurgical polish to a surface roughness of  $0.127\text{-}\mu\text{m}$  ( $5\text{-}\mu\text{in.}$ )  $R_a$  or finer.

7.6 *Metallurgical Evaluation of Polished Test Specimens:*

7.6.1 Unless otherwise specified, observe test specimen under  $100$  to  $500\times$  magnification for end grain pitting and intergranular attack.

7.6.1.1 Measure maximum width and depth of pit as illustrated in Fig. 3.

7.6.1.2 Measure maximum length of intergranular attack starting from the surface of the metal into the bulk material in the grain direction as illustrated in Fig. 3.

7.6.1.3 Guide G 46 may be permitted to be used as an alternate method to evaluate pitting only.

7.6.2 See Terminology G 15 for definitions of terminology relating to corrosion and corrosion testing as a guidance document.

## 8. Report

8.1 Report the following information:

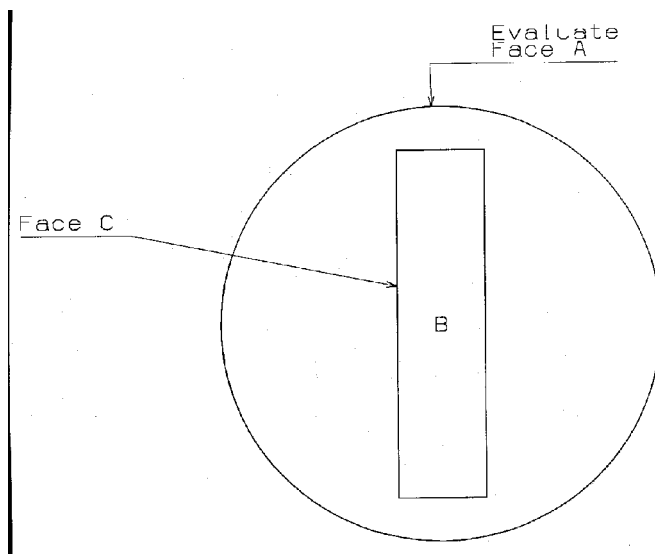

FIG. 2 Mounted Specimen

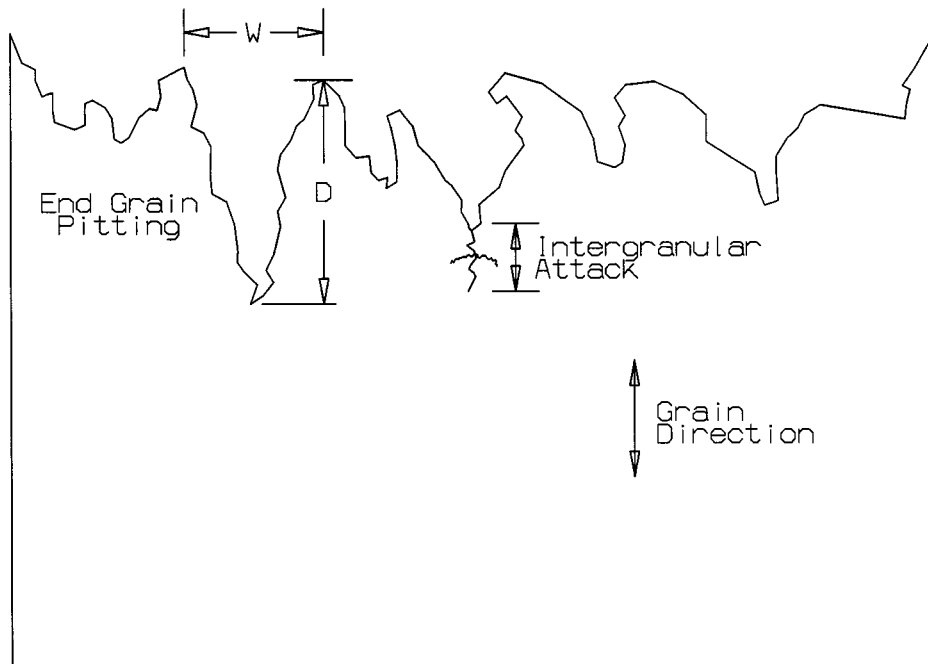

FIG. 3 Maximum Width and Depth of Pit

- 8.1.1 Contents of test report,
  - 8.1.1.1 Description of chemical tested,
    - Examples: part number, formula, MSDS, or other manufacturer's identification number, and so forth,
- 8.1.2 Manufacturer of chemical,
- 8.1.3 Batch number or lot number,
- 8.1.4 Date of manufacture,
- 8.1.5 Dilution ratio (if applicable),
- 8.1.6 Test alloy and material specification (metallurgical heat number is optional),
- 8.1.7 Exposure method,
  - Examples: immersion, dip and hang, brush, spray, or other,
- 8.1.8 Exposure temperature °C to (°F),
- 8.1.9 Exposure period (seconds, minutes, hours, or days),
- 8.1.10 Measured depth of maximum pit and magnification,
- 8.1.11 Measured width of maximum pit and magnification,
- 8.1.12 Measured length of maximum intergranular corrosion and magnification,
- 8.1.13 Signature of test engineer and date,
- 8.1.14 Approval signature of laboratory supervisor or manager and date,
- 8.1.15 Date tested,
- 8.1.16 Qualification document for conformance testing (if applicable),
  - Examples: material specifications, process specifications, procurement specifications.

## 9. Precision and Bias

9.1 The spread in data obtained from a number of test laboratories or round robin testing should be used to demonstrate reproducibility and reliability of the test data. No information is available on the repeatability when a laboratory conducts several identical tests. Additionally, when testing chemicals requiring dilutions, water quality and composition may well play a role in the corrosion rates and mechanism effecting the results of this practice.

9.2 Actual aircraft processes in the production environment should give the most representative results; however, the test results may not be completely evaluated with respect to ambient conditions which can vary from day to day.

9.3 This practice should be used over the range of conditions the process is expected to operate. For example, if the process will be used from 10 to 38.7°C (50 to 100°F), data points should be generated from 10 to 37°C (50 to 100°F) for completeness.

## 10. Keywords

10.1 aircraft; maintenance chemicals; corrosion; depth; end grain; inspection; grain pitting; intergranular attack; maintenance; metallographic; metallographic inspection; pit; pitting corrosion; pitting depth

*ASTM International takes no position respecting the validity of any patent rights asserted in connection with any item mentioned in this standard. Users of this standard are expressly advised that determination of the validity of any such patent rights, and the risk of infringement of such rights, are entirely their own responsibility.*

*This standard is subject to revision at any time by the responsible technical committee and must be reviewed every five years and if not revised, either reapproved or withdrawn. Your comments are invited either for revision of this standard or for additional standards and should be addressed to ASTM International Headquarters. Your comments will receive careful consideration at a meeting of the responsible technical committee, which you may attend. If you feel that your comments have not received a fair hearing you should make your views known to the ASTM Committee on Standards, at the address shown below.*

*This standard is copyrighted by ASTM International, 100 Barr Harbor Drive, PO Box C700, West Conshohocken, PA 19428-2959, United States. Individual reprints (single or multiple copies) of this standard may be obtained by contacting ASTM at the above address or at 610-832-9585 (phone), 610-832-9555 (fax), or [service@astm.org](mailto:service@astm.org) (e-mail); or through the ASTM website ([www.astm.org](http://www.astm.org)).*