



Designation: D 2559 – 034

Standard Specification for Adhesives for Structural Laminated Wood Products for Use Under Exterior (Wet Use) Exposure Conditions¹

This standard is issued under the fixed designation D 2559; the number immediately following the designation indicates the year of original adoption or, in the case of revision, the year of last revision. A number in parentheses indicates the year of last reapproval. A superscript epsilon (ε) indicates an editorial change since the last revision or reapproval.

This standard has been approved for use by agencies of the Department of Defense.

1. Scope*

1.1 This specification covers adhesives suitable for the bonding of wood, including treated wood, into structural laminated wood products for general construction, for marine use, or for other uses where a high-strength, waterproof adhesive bond is required.

1.2 The requirements of the adhesive are based on the performance of the adhesive in laminated wood as measured by:

1.2.1 Resistance to shear by compression loading,

1.2.2 Resistance to delamination during accelerated exposure to wetting and drying, and

1.2.3 Resistance to deformation under static load.

1.3 The values stated in SI units are to be regarded as the standard. The values in parentheses are for information only.

1.4 *This standard does not purport to address all of the safety concerns, if any, associated with its use. It is the responsibility of the user of this standard to establish appropriate safety and health practices and determine the applicability of regulatory limitations prior to use.*

¹ This specification is under the jurisdiction of ASTM Committee D14 on Adhesives and is the direct responsibility of Subcommittee D14.30 on Wood Adhesives. Current edition approved May 10, 2003⁴. Published ~~June 2003~~ May 2004. Originally approved in 1966. Last previous edition approved in 2000³ as D 2559 – 00³.

*A Summary of Changes section appears at the end of this standard.

2. Referenced Documents

2.1 ASTM Standards:²

D 9 Terminology Relating to Wood

D 143 Test Methods for Small Clear Specimens of Timber

D 905 Test Method for Strength Properties of Adhesive Bonds in Shear by Compression Loading

D 907 Terminology of Adhesives

D 1165 Nomenclature of Domestic Hardwoods and Softwoods

D 1583 Test Method for Hydrogen Ion Concentration of Dry Adhesive Films

D 2555 Test Methods for Establishing Clear Wood Strength Values

D 3535 Test Method for Resistance to Deformation Under Static Loading for Structural Wood Laminating Adhesives Used Under Exterior (Wet Use) Exposure Conditions

~~D 4300 Test 4442 Test Methods for Ability Direct Moisture Content Measurement of Adhesive Films to Support or Resist the Growth of Fungi³~~ Wood and Wood-Base Materials

~~D 5266 Practice 4300 Test Methods for Ability of Adhesive Films to Support or Resist the Growth of Fungi~~

D 5266 Practice for Estimating the Percentage of Wood Failure in Adhesive Bonded Joints

E 6 Terminology Relating to Methods of Mechanical Testing

E 41 Terminology Relating to Conditioning

E 691 Practice for Conducting an Interlaboratory Study to Determine the Precision of a Test Method

3. Terminology

3.1 *Definitions*—Many terms in this specification are defined in Terminology D 907.

3.2 *Definitions of Terms Specific to This Standard:*

3.2.1 *delamination, n*—the separation of layers in a laminate because of failure of the adhesive, either in the adhesive itself or at the interface between the adhesive and the adherend.

3.2.2 *glulam, n*—synonym for *structural-glued-laminated timber*.

NOTE 1—The following ASTM standards may be referred to for other terms used in this specification: Nomenclature D 1165, Terminologies D 9, E 6, and E 41.

3.2.3 *laminated wood product, n*—a fabricated wood assembly resulting from the bonding together of two or more laminations, all with the direction of grain essentially parallel, to form a larger piece such as a structural member.

3.2.3.1 *Discussion*—The individual laminations themselves may be made up of two or more pieces both in width and length.

3.2.4 *structural-glued-laminated timber, n*— an engineered stress-related product of a timber laminating plant comprising assemblies of specially selected and prepared wood laminations securely bonded together with adhesives, with the following characteristics: (1) the grain of all laminations is approximately parallel longitudinally; and (2) the laminations may be comprised of pieces end-joined to form any length, of pieces placed or glued edge-to-edge to make wider ones or of pieces bent to curved form during gluing. (Synonym: *glulam*) ANSI/AITC A190.1–1992. American National Standard for Wood Products—Structural Glued Laminated Timber (Edited to conform with ASTM format).

4. Significance and Use

4.1 Structural design based on strength of material principles of the structural components, including the adhesive and the adhesive's potential durability, requires that the suitability for structural wet use exposure be predicted.

4.2 Performance of the adhesive for resistance to shear by compression loading, resistance to delamination during accelerated aging exposure to wetting and drying, and resistance to deformation under load data developed by this test aid in determining if the adhesive is suitable for structural wet use.

5. Classification

5.1 The manufacturer shall classify the adhesive as to general type. Typical classifications include: resorcinol, phenol-resorcinol, phenol, melamine, etc.

5.2 The manufacturer may be considered to be the testing facility certifying the adhesive.

6. Ordering Information

6.1 The manufacturer will furnish the adhesive in any suitable form agreeable to the purchaser.

7. Fillers and Extenders

7.1 If amylaceous or protein fillers and extenders are used, the adhesive must not only pass requirements of this specification, but in addition, possess sufficient antifungal properties to inhibit the growth of selected fungal species when tested in accordance

² For referenced ASTM standards, visit the ASTM website, www.astm.org, or contact ASTM Customer Service at service@astm.org. For *Annual Book of ASTM Standards*, Vol 04.10, volume information, refer to the standard's Document Summary page on the ASTM website.

with Test Method D 4300. The adhesive manufacturer shall state in his bulletin whether such materials are ~~present, and, if any, the approximate percentage by weight. present.~~

8. Chemical Requirements

8.1 The cured adhesive film shall develop a pH value of not less than 2.5 when tested in accordance with Test Method D 1583.

9. Physical Requirements

9.1 The adhesive manufacturer shall furnish written instructions stating the general chemical type of adhesive, its storage and mixing procedure, the method of wood preparation, and any other data which is pertinent to the use of the adhesive in the manufacture of laminated wood products.

9.2 The adhesive must pass the tests required by this specification for all limiting conditions recommended in the manufacturer's bulletin. The information furnished by the manufacturer should include each of the following for each species of wood included in his recommendations:

9.2.1 Limits of working life,

9.2.2 Minimum and maximum open and closed assembly times as dictated by temperature, moisture content of the wood, mix age, etc., ~~as commonly encountered under mill conditions, etc.,~~

9.2.3 ~~Minimum spread rates for commonly encountered stock assembly times and mill conditions, use conditions as indicated in 9.2.2,~~

9.2.4 Minimum cure time and temperature of ~~glueline~~ bondline for complete cure,

9.2.5 Minimum pressure, and

9.2.6 Maximum and minimum allowable moisture content of the wood.

10. Selection and Preparation of Wood for Testing of Adhesives

10.1 Test the adhesive on the species of wood to be bonded or for which it is recommended including chemically treated wood ~~(see Note 2)~~. The wood shall have a maximum slope of grain of 1 in 15 on any face or any edge. The wood shall contain no knots larger than 3 mm (1/8 in.) in diameter and shall be free from decay, machining defects (such as chipped grain, dubbed ends, feed roll polish, coarse knife marks, and feed roll compression), and any drying defects such as case hardening, collapse, splits, or checks. Use only flat-grained wood.

NOTE 2—Grouping of species is not permitted.

10.2 Wood Moisture Content:

10.2.1 Ambient Curing Adhesives—Condition the wood at $23 \pm 2^\circ\text{C}$ ($73.4 \pm 3.6^\circ\text{F}$) and a relative humidity of 50 to 70 % (preferably 65 %) until a moisture content of 8 to 14 % or, preferably 9 to 12 %, has been attained.

10.2.2 Hot Press Curing Adhesives—Condition the wood at $23 \pm 2^\circ\text{C}$ ($73.4 \pm 3.6^\circ\text{F}$) and a relative humidity of less than 50 % until a moisture content of 3 to 8 % has been attained.

10.3 Freshly surface each lamination before bonding with the adhesive to be tested. Remove at least 0.4 mm (1/64 in.) from each face within 24 h of bonding. The machining tolerances for each lamination used in preparing the test samples shall be no greater than ± 0.25 mm (0.01 in.) between laminations and ± 0.20 mm (0.008 in.) within laminations.

11. Preparation of Laminated Wood Test Members

11.1 Ambient-Curing Adhesives:

11.1.1 Prepare six pieces of wood of the same species for each laminated wood member. Each of the six pieces shall have ~~an average~~ a specific gravity equal to or exceeding the minimum requirement of Table 1. Each piece of wood shall be ~~nominal~~ 19-mm (0.75-in.) thick lumber ~~(see Note 2, 3)~~ at least 140 mm (5 1/2 in.) in width and 1 m (40 in.) long. Orient the direction of the annular growth rings when viewed on the end of the laminations in the laminated wood test-beam member so that they are alternated.

NOTE 2, 3—This thickness would normally come from "nominal 1-in. lumber."

11.1.1.1 If equipment prevents the preparation of laminated wood test-beams members 1 m (40 in.) in length, prepare duplicate 610-mm (24-in.) laminated wood members to obtain at least an equivalent number of test specimens.

11.1.2 Apply the adhesive uniformly to the contacting faces of each lamination in accordance with the manufacturer's instructions.

11.1.3 Place the laminated wood members under pressure for a period of time and at the ~~glueline~~ bondline temperature specified by the manufacturer of the adhesive.

11.1.4 Conditioning— Condition the laminated wood members at $23 \pm 2^\circ\text{C}$ ($73.4 \pm 3.6^\circ\text{F}$) and a relative humidity of 50 to 70 % (preferably 65 %) for the minimum time recommended by the manufacturer for each curing temperature used during the pressure period, and test immediately.

11.2 Hot-Press Curing Adhesives :

11.2.1 Prepare six pieces of wood of the same species for each laminated test member. Each of the six pieces shall have a specific gravity equal to or exceeding the minimum requirement of Table 1. Each piece of wood shall be 19 mm (0.75 in.) thick

TABLE 1 Required Shear Strength for Structural Laminated Wood Products

NOTE 1—For species other than those given, strength values shall be based on the values for shear parallel to grain at 12 % moisture content. Base the minimum allowable specific gravity on volume for wood at 12 % moisture content. These values may be found in Table 4-2 of the Wood Handbook, U.S. Department of Agriculture, No. 72 (1974 edition). Adjustments for changes in moisture content shall be on the basis of 3 % increase or decrease in strength for each 1 % change in moisture content.

NOTE 2—It has been documented that bonded shear specimens (Test Method D 905 type specimen) on the average provide higher shear strength values than solid wood specimens (Test Methods D 143 type specimen). It may appear to be inconsistent to compare shear strength data of bonded specimens to data based on 90 % of the solid wood shear strength found in the Wood Handbook. However, the goal of evaluating shear strength of adhesives in Specification D 2559 is to demonstrate the shear strength in a laminated product (tested using Test Method D 905 type specimens) meets or exceeds the strength of a solid wood beam when tested by standard procedures for solid wood (Test Methods D 143 type specimen).

NOTE 3—For species not found in the 1999 Wood Handbook, values for shear parallel to grain at 12 % moisture content using solid wood are to be obtained on clear, straight-grained specimens following specific ASTM test methods and procedures. These include Test Methods D 143 and D 2555. Test Methods D 143 testing is to be performed on a minimum of 28 shear strength specimens.

Species	Required Shear Strength, KPa (psi) ^A			Increase in Shear Strength for Each 1 % Decrease in Moisture Content, %	Minimum Allowable
	Moisture Content of Wood at Test				
	8 %	12 %	16 %		
Douglas fir	8 140 (1 180)	7 380 (1 070)	6 620 (960)	1.7	
Hemlock, western	8 830 (1 280)	8 070 (1 170)	7 310 (1 060)	2.5	
Larch, western	10 690 (1 550)	9 730 (1 410)	8 830 (1 280)	2.9	
Larch, western	9 400 (1 370)	9 730 (1 410)	8 830 (1 280)	2.9	
Oak, white	15 180 (2 200)	13 800 (2 000)	12 420 (1 800)	3.4	
Oak, white	14 300 (2 080)	12 400 (1 800)	11 000 (1 560)	3.4	
Pine, southern	9 940 (1 440)	9 040 (1 310)	8 140 (1 180)	3.7	
Pine, southern	10 400 (1 510)	9 040 (1 310)	8 140 (1 180)	3.7	
Redwood	7 110 (1 030)	6 490 (940)	5 860 (850)	2.3	

^A Use the same shear strength values for a specific species when chemically treated wood is used.

^B Based on weight when oven dry and volume at 12 % moisture content.

lumber (see Note 4) at least 140 mm (5½ in.) in width and 1 m (40 in.) long as allowed in 11.1.1.1. Orient the direction of the annular growth rings when viewed on the end of the laminations in the laminated wood test member so that they are alternated.

NOTE 4—This thickness would normally come from “nominal 1 in. lumber.”

11.2.1.1 If equipment prevents the preparation of laminated wood test members 1 m (40 in.) in length, prepare duplicate 610 mm (24 in.) laminated wood members to obtain at least an equivalent number of test specimens.

11.2.2 Apply the adhesive uniformly to the contacting faces of each lamination in accordance with the manufacturer’s instructions.

11.2.3 Hot press three-layer assemblies at the pressure, press temperature, and to the bondline temperature specified by the manufacturer of the adhesive. These three-layer assemblies, after conditioning in accordance with 11.1.4, are assembled into six laminated wood test members using a Specification D 2559 approved ambient-curing adhesive for the center bondline in accordance with 11.1.3.

11.2.4 *Conditioning*—Condition the laminated wood members at $23 \pm 2^\circ\text{C}$ ($73.4 \pm 3.6^\circ\text{F}$) and a relative humidity of 50 to 70 % (preferably 65 %) for the minimum time recommended by the manufacturer for each curing temperature used during the pressure period, and test immediately.

12. Number of Tests

12.1 Prepare ~~three laminated~~ six laminate wood members for tests, one at each of the limiting conditions listed, but all other factors, as itemized in 9.1 and 9.2, shall be in accordance with the manufacturer’s instructions.

12.1.1 Liquid adhesives:

- 12.1.1.1 Minimum open assembly time with minimum closed assembly time,
- 12.1.1.2 Maximum open assembly time with maximum closed assembly time, and
- 12.1.1.3 Minimum open assembly time with maximum closed assembly time.

12.1.2 Film adhesives:

- 12.1.2.1 Minimum cure time,
- 12.1.2.2 Minimum cure temperature, and
- 12.1.2.3 Minimum pressure.

13. Preparation of Test Samples

13.1 Dress the ~~three~~ laminated wood members, prepared in accordance with Sections 11 and 12, on the sides to a uniform width of 127 mm (5 in.) at the completion of the conditioning period. Trim 76 mm (3 in.) off one end of each of these ~~beams~~ members and discard it. Cut the remaining trimmed ~~beams~~ members into five sections as shown in Fig. 1. Use the 102-mm (4-in.) sections labeled “A” for conducting tests in resistance to shear by compression loading in accordance with Section 14, and use the 254-mm (10-in.) sections labeled “B” for conducting resistance to delamination tests in accordance with Section 15. Discard the remaining waste trim portion.

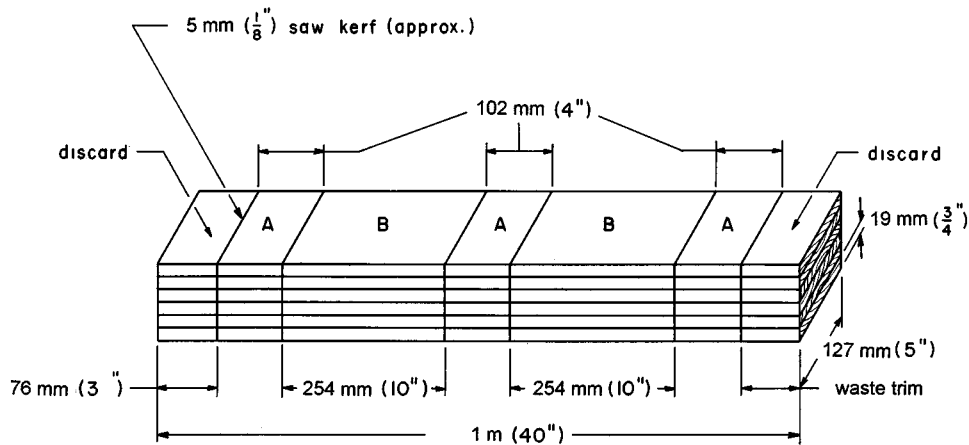

FIG. 1 Laminated Test Beam

13.1.1 If duplicate laminated wood members are made in accordance with 11.1.1.1 or 11.2.1.1 to obtain at least an equivalent number of test specimens, then trim 51 mm (2 in.) off each end. Utilize the remaining trimmed beam, member, 508 mm (20 in.) in length by cutting two 254-mm (10-in.) sections labeled “B” or one 254-mm section “B” and two 102-mm (4-in.) sections “A” as shown in Fig. 1. If two “B” sections are prepared then make separate specimens for shear testing by preparing two-player laminated wood members and specimens in accordance with Test Method D 905. Make and test these specimens from the same species of wood, at exactly the same time, and under the same conditions as required for other test samples in this specification.

TEST METHODS

14. Resistance to Shear by Compression Loading

14.1 *Apparatus*—The testing machine capacity is to be of about 66900 N (15 000 lb) in compression or of sufficient capacity to test the species of wood in use. Equip the testing machine with a shearing tool containing a self-aligning seat to ensure uniform lateral distribution of the load. The machine shall be capable of maintaining a uniform rate of loading such that the load is applied with a continuous motion of the movable head to a maximum rate load not to exceed 13-mm (0.50-in.)/min. The shearing tool shown in Fig. 1 of Test Method D 905 has been found satisfactory. Locate the testing machine in an atmosphere such that the moisture content of the test pieces developed in accordance with 11.1.4 is not noticeably altered during testing.

14.2 Samples:

14.2.1 Prepare at least six samples for testing in shear by compression loading. When stair-step shear samples are used, cut two from each of the 102-mm (4-in.) sections labeled “A” in Fig. 1. When separate laminated wood samples are made in accordance with 11.1.1.1 or 11.2.1.1 make at least six test samples and cut at least five test specimens from each as specified by the dimensions of Figs. 2 and 3 of Test Method D 905.

14.2.2 The stair-step shear specimens shall conform to the form and dimensions shown in Fig. 2. Take care in preparing the test specimens to assure that the grain direction in the wood is parallel to the direction of loading during test. The loaded surfaces shall be smooth and parallel to each other and perpendicular to the height. When sawing the bonded assembly, exercise care to ensure that the saw cuts to, but not beyond, the adhesive line. Measure the width and height of the specimen at the adhesive line to the nearest 0.25 mm (0.01 in.) to determine the shear area. All requirements above shall apply when individual test specimens are cut from the separately laminated test members of Test Method D 905.

14.2.3 Condition the individual test specimens in the conditioning environment described in 11.1.4 and 11.2.4 to a target moisture content of 8, 12, or 16 % for species listed in Table 1. For all other species condition to a target moisture content of 12 %. The allowable variation in the target moisture content before testing is ± 1 %. Moisture content is to be determined using Test Methods D 4442.

14.3 Test the test specimens cut from the test samples described in 14.2 to failure. Report the shear strength calculated in kilopascals (kPa) (pounds per square inch (psi)) based on the bonded area between two laminations rounded to the nearest 0.0645 mm² (0.01 in.²), for each test specimen together with the estimated percentage wood failure. Practice D 5266 has been found useful in estimating the percentage of wood failure in adhesive bonded joints.

14.4 Requirements:

14.4.1 The average shear strength for each group of laminated wood members made at one manufacturing condition as specified in Section 12, and tested as described above shall be not less than the values specified in Table 1 at the appropriate moisture content of the wood.

14.4.2 The average wood failure for each group of laminated wood members made at one condition and tested as prescribed in Section 14 shall be not less than 75 % for all species listed in Table 1.

14.5 Retest:

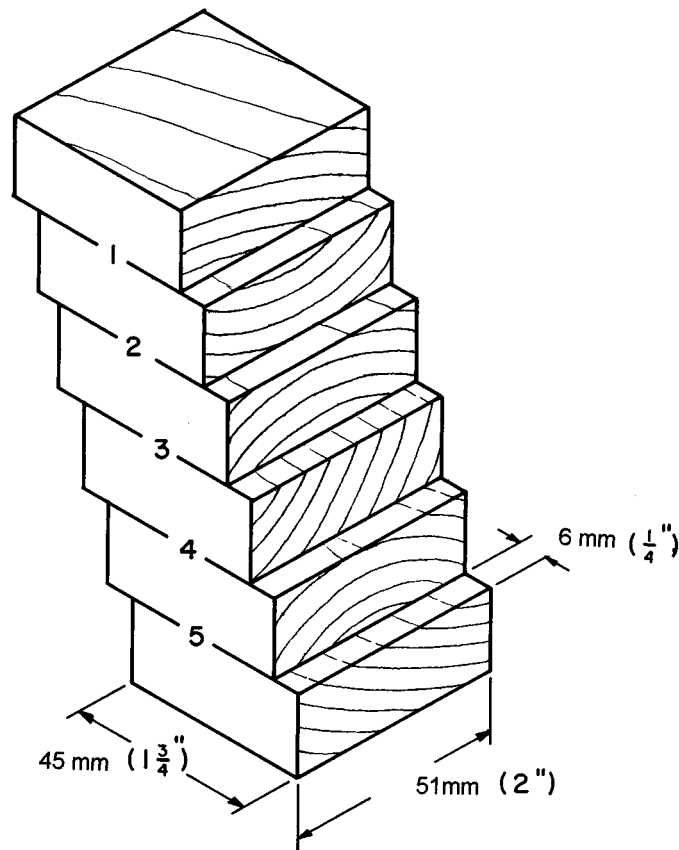

FIG. 2 Stair-Step Shear Specimen

14.5.1 If the strength requirements of 14.4 are not satisfied, but the wood failure value is 95 % or more, retest the adhesive.

15. Resistance to Delamination During Accelerated Exposure

15.1 Apparatus:

15.1.1 An autoclave or similar pressure vessel capable of withstanding at least 550 kPa (80 psi) is required for impregnating the specimens with water. Equip the vessel with a vacuum pump or similar device capable of drawing vacuum of at least 85 kPa (25 in.) Hg (sea level) in the vessel and provide a method for obtaining pressures to 517 kPa (75 psig). Equip the vessel with a steam inlet capable of providing steam at 100°C (212°F) for 1½ h.

15.1.2 An oven capable of maintaining 65.5 ± 2°C (150 ± 3.6°F) with sufficient circulation to remove moisture from the chamber is required for drying the specimens.

15.1.3 Circular fluorescent desk lamp with 5× viewing magnifier in the center of the lamp. Equivalent light sources and magnifier may be substituted for the above.

15.1.4 Machinist's scale graduated in 0.01 and 0.10 divisions.

15.2 Samples—P:

15.2.1 For ambient-curing adhesives prepare six delamination specimens representing three from each 254-mm (10-in.) section labeled "B" in Fig. 1. Cut each 254-mm section into three 76-mm (3-in.) specimens with the 76-mm dimension parallel to the grain direction in the wood (7620 mm, (300 in.) wood. The total length of adhesive glue-line, 635 mm, (25 in.) bondlines on each end grain face of is 635 mm (25 in.). On six specimens this equals 7620 mm (300 in.). Test eighteen specimens (six from each of three beams laminated wood test members prepared in accordance with Sections 11, 12, and 13 to certify each adhesive on each species of wood to be laminated.

15.2.2 For hot-press curing adhesives prepare eight delamination specimens (four from each 610 mm (24 in.) laminated wood member as allowed in 13.1.1) with dimensions as specified in 15.2.1. In order to achieve the required 7620 mm (300 in.) of test bondlines (as specified in 15.2.1) with hot-pressed laminated wood members, the end grain faces of 7.5 specimens are required. Thus for hot-press curing adhesives, four test bondlines 508 mm (20 in.) on each end grain face of 8 specimens will be examined for a total of 8128 mm (320 in.). Test twenty four specimens (four from each of six laminated wood test members prepared in accordance with Sections 11-13) to certify each adhesive on each species of wood to be laminated.

15.3 Procedure:

15.3.1 Weigh and record to the nearest 1 g (0.035 oz) the weight of each test specimen. Place the eighteen 76-mm (3-in.) test specimens in the pressure vessel described in 15.1.1, weigh down, and admit water at a temperature of 18 to 27°C (65 to 80°F)

in sufficient quantity so that the specimens are completely submerged throughout the test. Separate the test specimens by stickers, wire screens, or other means in such a manner that all end grain surfaces are freely exposed to the water. Draw a vacuum of at least 85 kPa (25 in.) Hg (sea level) and hold for 5 min. Release the vacuum and apply pressure of 517 ± 14 kPa (75 ± 2 psi) for 1 h. Repeat the vacuum-pressure cycle with the test specimens remaining submerged, making a two-cycle impregnating period requiring a total of approximately 2½ h (Note 3; 5). Dry the test specimens in the oven described in 15.1.2 at 65.5 ± 2°C (150 ± 3.6°F) for a period of between 21 and 22 h, with sufficient air circulation to lower their weight to within 15 % of the original test specimen weight. During drying, place the test specimens at least 51 mm (2 in.) apart with the end-grain surfaces parallel to the stream of air. This completes the first cycle.

NOTE 35—This should increase the weight of the test specimens by at least 50 %. If the weight is not increased by this amount, continue this cycle until the weight has increased at least 50 %.

15.3.2 Return the specimens to the pressure vessel and admit steam at 100°C (212°F) for 1½ h, with drains open so the wet condensate is removed as formed, after which admit water at 18 to 27°C (65 to 80°F) and apply a pressure of 517 ± 14 kPa (75 ± 2 psi) for 40 min. Dry the specimens in the oven as above. This completes the second cycle.

15.3.3 Repeat the first cycle, making a total test period of 3 days. Record the data as outlined in 15.4.1.

15.4 Requirements:

15.4.1 At the end of the final drying period specified in Section 15, visually examine each specimen. Immediately measure, to the nearest 1.27 mm (0.05 in.), the total length of open joints (delamination) on each end-grain surface of each specimen and record in Table 2. Do not record as delamination any failure in the wood due to checking or small isolated knots. Do not record any delamination that is less than 2.54 mm (0.10 in.) in length and more than 5 mm (0.20 in.) away from any recordable delamination. Record as delamination, any failure where shallow wood failure is noted and no other factors related to the wood, such as grain angle and growth-ring structure, are influencing the delamination. Do not include as delamination, any failure where a significant amount of wood failure is noted and which is influenced by factors such as grain angle or growth-ring structure. Measure and record in Table 2 the total length of end grain bond line for each of the specimens. For total delamination length, add together the recorded delamination for all each bond lines on the two end-grain surfaces of all the specimens. Report as percent delamination, the total delamination length in each bond line of all the specimens divided by the total length of all the bond lines of all specimens multiplied by 100 and record in Table 2 (see Note 7). The delamination for each manufacturing condition (see Section 12) shall not exceed ~~5 %~~ 1 % for any bond line in the laminated test member for softwoods and ~~8 %~~ or 1.6 % for hardwoods. Table 2 is provided to record all measurements and calculate percent delamination.

NOTE 46—In order to ensure that the core moisture content will exceed the shell moisture content and thus hold the delamination open and visible, the laminated wood test specimens shall be removed from the final drying cycle in the oven, as prescribed in 15.3.1, when the final weight of each specimen is not less than 1.15 nor more than 1.25 times the weight before original treatment.

~~15.4.2 No more than one-fifth of~~

NOTE 7—For hot-pressed adhesives the total permissible delamination (1 % for softwoods and 1.6 % for hardwoods) center bondline is evaluated as

TABLE 2 ASTM D 2559 Test Results

Adhesive:	_____											
Assembly time:	_____											
Species:	_____											
Softwood:	_____											
Hardwood:	_____											
	Measured Delamination Length By Specimen Number, in. ^A							Bond Line Delamination, in. ^B	Bond Line Length, in. ^C	Calculated Delamination, % ^D	Allowable Delamination Softwood, %	Allowable Delamination Hardwood, %
Bond Line	1	2	3	4	5	6	7 ^E	8 ^E				
A									4	4.6		
A									1	1.6		
B									4	4.6		
B									1	1.6		
C									4	4.6		
C									1	1.6		
D									4	4.6		
D									1	1.6		
E									1	1.6		
Total									5	8		

^ASum of both end grain surfaces for each bond line.

^BSum of delamination for both end grain surfaces of all specimens for each bond line.

^CSum of end grain bond line length of all the specimens.

^DBond line delamination (total delamination length in the bond line of all specimens) divided by bond line length (total length of all the bond lines of all specimens) multiplied by 100.

^EUsed only for hot pressing adhesives.

well as the test bondlines to occur in any one bond line of ensure that the assembly. Specification D 2559 ambient-curing adhesive performs as expected.

15.5 *Retest*—If the requirements of 15.4.1 and 15.4.2 are not satisfied in any one laminated wood member, including the center bondline of a hot-pressed laminated test member, then test one additional member. If all the requirements are met in retest, disregard the results of the original test.

16. Resistance to Deformation Under Static Loading

16.1 *Procedure*—Test the adhesive in accordance with Test Method D 3535 using four multijoint specimens, each loaded to 218.2-kg (480-lb) total load or 1655 kPa (240 psi). Expose two specimens to an environment of 71°C (160°F) at ambient humidity and the other two at 27°C (80°F) at 90 % relative humidity. The exposure period shall be 7 days in both cases.

16.2 *Measurement*— At the end of the exposure period, measure the total length of slippage (deformation) to the nearest 0.127 mm (0.005 in.). Add the total deformation for both test specimens of each variable combination and report in millimetres (inches).

16.3 *Requirement*— The total deformation shall not exceed 3.63 mm (0.139 in.) for the two specimens combined from each variable combination. If either variable combination exceeds the allowable limit, the adhesive has failed.

16.4 *Retest*—If the deformation requirements of 16.3 are not satisfied, but the wood failure is 95 % or more, retest the adhesive.

17. Report

17.1 The report shall include the following:

17.1.1 Identification of the adhesive used by class, number, or manufacturer’s mark.

17.1.2 Application and bonding conditions used for the specimens.

17.1.3 Wood species evaluated and if not listed in Table 1 the adjusted (90 %) shear strength parallel to grain at 12 % moisture content. Report whether from the Wood Handbook or from testing following guidance in Note 3 in Table 1.

17.1.4 Wood preparation and conditioning including specific gravity and moisture content at time of bonding.

17.1.5 Temperature and relative humidity at time of bonding.

17.1.6 Number of specimens tested.

17.1.7 Number of laminated wood members represented.

17.1.8 Maximum and minimum values obtained. Include the standard deviation or all individual test values, or both, in the report at the option of either the purchaser or the manufacturer of the adhesive.

17.1.9 The average value for each test and the average percentage wood failure for shear and creep resistance.

18. Precision and Bias

18.1 A round robin test was conducted on the test method for Resistance to Shear. The precision of shear strength testing has two components: within-laboratory (repeatability) and between-laboratory (reproducibility). The data from the round robin test was analyzed using Practice E 691. The precision of the test method is affected by many factors including, but not limited to: (1) the wood species, (2) grain direction, (3) growth ring orientation, (4) the quality of the bonded joint, (5) precision of the testing machine, and (6) the operator.

18.1.1 The round robin was done using southern yellow pine lumber. Table 3 gives the results of the round robin. The results are expressed as precision statistics within a laboratory (repeatability) and between-laboratories (reproducibility). Both standard deviation (s_r and S_R) and 95 % repeatability and reproducibility limits (r and R) were selected as precision statistics. The data generated by this round robin is available.

18.1.2 The 95 % repeatability and reproducibility limits were similar for both shear strength and estimated wood failure. This may indicate that the largest source of variability may be affecting all laboratories such as properties of the wood.

18.2 A round robin was conducted on the test method for Resistance to Delamination using three different species of wood (SPF, SYP, and Hem Fir). The results of the round robin were analyzed using Practice E 691.

18.2.1 Table 4 gives the results of the round robin. Both standard deviation (s_r and s_R) and 95 % repeatability and reproducibility limits (r and R) were selected as precision statistics. Since the reproducibility standard deviation (between laboratories) was not much larger than the repeatability standard deviation (within a laboratory), it may indicate that the largest variability was due to a factor which would affect all laboratories such as drying of the specimens or measuring the amount of observable delamination.

18.2.2 The precision of this test method is affected by many factors such as: wood species, grain direction, growth ring orientation, specific gravity of the wood, quality of the bonded joint, oven drying rate, and the operator (including reading of delamination). The data generated by this round robin is available.

TABLE 3 Shear Strength and Wood Failure Precision

	s_r^A	S_R^B	r^C	R^D
Shear Strength	159.8	175.6	447.4	491.7
Wood Failure	11.2	13.4	31.4	37.5

^A Standard Deviation Within-Laboratory (repeatability).

^B Standard Deviation Between-Laboratories (reproducibility).

^C 95 % Repeatability Limit (within a laboratory).

^D 95 % Reproducibility Limit (between laboratories).

TABLE 4 Cyclic Delamination Precision

	s_r^A	s_R^B	r^C	R^D
SPF	3.97	4.25	11.12	11.76
SYP	1.54	2.68	4.31	7.50
Hem Fir	5.01	9.18	14.02	25.70

^A Standard Deviation Within-Laboratory (repeatability).

^B Standard Deviation Between-Laboratories (reproducibility).

^C 95 % Repeatability Limit (within a laboratory).

^D 95 % Reproducibility Limit (between laboratories).

18.3 The test methods have no bias because the shear strength, wood failure, and percent delamination are defined by the testing methods.

19. Keywords

19.1 adhesive; delamination; glulam; laminated wood; shear strength; structural-glued-laminated timber

SUMMARY OF CHANGES

Subcommittee D14.30 has identified the location of selected changes to this standard since the last issue (D 2559-03) that may impact the use of this standard.

(1) Addition of referenced Test Methods D 4442 in 2.1.

(2) Addition of Note 2 to 10.1 that grouping of species is not permitted.

(3) Addition of 14.2.3 that requires conditioning shear specimens to a target moisture content prior to testing for Resistance to Shear. For species found in Table 1 the target moisture content is 8, 12, or 16 % and for all other species the target moisture content is 12 %.

(4) Revised 15.4.1 on measurement and reporting of delamination. The delamination requirement for each manufacturing condition shall not exceed 1 % for any bond line in the laminated test member for softwoods or 1.6 % for hardwoods.

(5) Revised Section 17 to include reporting wood species evaluated and if not listed in Table 1 the adjusted (90 %) shear strength parallel to grain.

(6) Revised Table 1 to provide uniformity on required shear strength on listed species by basing on 90 % of shear strength parallel to grain as reported in Table 4-3 of the 1999 Wood Handbook. The revision of Table 1 also provides requirements for determining shear strength of species not found in Table 1 but listed in the 1999 Wood Handbook and requirements for other species not found in the 1999 Wood Handbook.

(7) Changes to the standard to allow hot-press curing adhesives as well as ambient-curing adhesives to be evaluated:

(a) Revised 10.2 (Wood Moisture Content) to include information for both ambient-curing adhesives and hot-press adhesives.

(b) Revised Section 11 (Preparation of Laminated Wood Test Members) to include information for ambient-curing adhesives in 10.2.1 and for hot-press curing adhesives in 10.2.2. Information specific to hot-press curing adhesives for the preparation of Laminated Test Members is provided in 11.2.1-11.2.4.

(c) Revised Section 15 on Preparation of Specimens for Resistance to Delamination During Accelerated Exposure. Separate sections are provided for ambient-curing adhesives (15.2.1) and hot-press curing adhesives (15.2.2). In order for specimens prepared from hot-press curing adhesives to provide at least the same quantity of test bondline during the delamination test, eight delamination specimens are required compared to six specimens prepared from ambient-curing adhesives.

(d) Revised Table 2 for use with either ambient-curing adhesives or hot-press curing adhesives.

ASTM International takes no position respecting the validity of any patent rights asserted in connection with any item mentioned in this standard. Users of this standard are expressly advised that determination of the validity of any such patent rights, and the risk of infringement of such rights, are entirely their own responsibility.

This standard is subject to revision at any time by the responsible technical committee and must be reviewed every five years and if not revised, either reapproved or withdrawn. Your comments are invited either for revision of this standard or for additional standards and should be addressed to ASTM International Headquarters. Your comments will receive careful consideration at a meeting of the responsible technical committee, which you may attend. If you feel that your comments have not received a fair hearing you should make your views known to the ASTM Committee on Standards, at the address shown below.

This standard is copyrighted by ASTM International, 100 Barr Harbor Drive, PO Box C700, West Conshohocken, PA 19428-2959, United States. Individual reprints (single or multiple copies) of this standard may be obtained by contacting ASTM at the above address or at 610-832-9585 (phone), 610-832-9555 (fax), or service@astm.org (e-mail); or through the ASTM website (www.astm.org).