



Standard Test Method for Piles Under Static Axial Compressive Load¹

This standard is issued under the fixed designation D 1143; the number immediately following the designation indicates the year of original adoption or, in the case of revision, the year of last revision. A number in parentheses indicates the year of last reapproval. A superscript epsilon (ϵ) indicates an editorial change since the last revision or reapproval.

This test method has been approved for use by agencies of the Department of Defense. Consult the DoD Index of Specifications and Standards for the specific year of issue which has been adopted by the Department of Defense.

^{ε1} NOTE—Section 10 was added editorially in May 1994.

INTRODUCTION

This standard has been prepared to cover routine methods of testing to determine if a pile has adequate bearing capacity. The provisions permit the introduction of more detailed requirements and procedures when required to satisfy the objectives of the test program. While the procedures herein produce a relationship between applied load and pile settlement, the results may not represent long-term performance.

1. Scope

1.1 This test method covers procedures for testing vertical or batter piles individually or groups of vertical piles to determine response of the pile or pile group to a static compressive load applied axially to the pile or piles within the group. This test method is applicable to all deep foundation units that function in a manner similar to piles regardless of their method of installation. This test method is divided into the following sections:

	Section
Referenced Documents	2
Apparatus for Applying Loads	3
Apparatus for Measuring Movements	4
Loading Procedures	5
Procedures for Measuring Pile Movements	6
Safety Requirements	7
Report	8
Precision and Bias	9

1.2 The values stated in inch-pound units are to be regarded as the standard.

NOTE 1—Apparatus and procedures designated “optional” are to be required only when included in the project specifications or if not specified, may be used only with the approval of the engineer responsible for the foundation design. The word “shall” indicates a mandatory provision and “should” indicates a recommended or advisory provision. Imperative sentences indicate mandatory provisions. Notes, illustrations, and appendixes included herein are explanatory or advisory.

NOTE 2—This test method does not include the interpretation of test results or the application of test results to foundation design. See Appendix XI for comments regarding some of the factors influencing the interpretation of test results. A qualified geotechnical engineer should interpret the test results for predicting pile performance and capacity. The term “failure” as used in this method indicates rapid progressive settlement of the pile or pile group under a constant load.

1.3 *This standard does not purport to address all of the safety concerns, if any, associated with its use. It is the responsibility of the user of this standard to establish appropriate safety and health practices and determine the applicability of regulatory limitations prior to use.*

2. Referenced Documents

- 2.1 *ASTM Standard:*
D 3689 Method of Testing Individual Piles Under Static Axial Tensile Load²
- 2.2 *American National Standards Institute Standard:*
B30.1 Safety Code for Jacks³

3. Apparatus for Applying Loads

3.1 General:

3.1.1 The apparatus for applying compressive loads to the test pile or pile group shall be as described in 3.3, 3.4, or 3.5 or as otherwise specified and shall be constructed so that the loads are applied to the central longitudinal axis of the pile or pile group to minimize eccentric loading. Paragraph 3.3 is suitable for applying axial loads to individual vertical or batter piles; 3.4 and 3.5 are suitable for applying vertical loads only.

NOTE 3—When a pile group is subject to vertical test loads, cap rotations and horizontal displacements could occur. The occurrence of such movements and the necessary reactions to resist such movements if they are prohibited should be considered when designing and constructing the loading apparatus for the group test.

NOTE 4—If it is not feasible to apply axial test loads to a batter pile, the results of a test on a similar nearby vertical pile generally may be used to evaluate the axial bearing capacity of the batter pile.

¹ This test method is under the jurisdiction of ASTM Committee D-18 on Soil and Rock and is the direct responsibility of Subcommittee D18.11 on Deep Foundations.

Current edition approved March 2, 1981. Published May 1981. Originally published as D 1143 – 50 T. Last previous edition D 1143 – 74.

² *Annual Book of ASTM Standards*, Vol 04.08.

³ Available from American National Standards Institute, 1430 Broadway, New York, NY 10018.

3.1.2 Where feasible, the immediate area of the test pile or pile group shall be excavated to the proposed pile cut-off elevation. The test pile(s) shall be cut off or built up to the proper grade as necessary to permit construction of the load-application apparatus, placement of the necessary testing, and instrumentation equipment, and observation of the instrumentation. Where necessary, the unsupported length of the test pile(s) shall be braced to prevent buckling without influencing the test results.

3.1.3 If the head of the pile has been damaged during driving, the damaged portion shall be removed prior to the test. For tests on pile groups, the piles shall be capped with a reinforced concrete cap designed and constructed in accordance with accepted engineering practice for the anticipated loads.

NOTE 5—Consideration should be given to providing a nominal clear space between the cap and the ground surface to eliminate any support offered by the soil under short-term loading. A properly constructed steel grillage may serve as an adequate pile cap for testing purposes.

3.1.4 In 3.3 and 3.4 and for a test on an individual pile in 3.5, a steel bearing plate(s) (test plate(s)) of sufficient thickness to prevent it from bending under the loads involved (but not less than 2 in. (50 mm)) shall be centered on the pile or pile cap and set perpendicular to the longitudinal axis of the pile or piles within the group, except that for tests on pile groups involving the use of two or more separate loading points, a test plate shall be used at each loading point and such plates shall be arranged symmetrically about the centroid of the group. For tests on individual piles, the size of the test plate shall be not less than the size of the pile butt nor less than the area covered by the base(s) of the hydraulic jack(s); for tests on pile groups, the size of the test plate(s) shall be not less than twice the area covered by the base(s) of the hydraulic jack(s).

3.1.5 For tests on precast or cast-in-place concrete piles or on pile groups, the test plate when used shall be set in high-strength quick-setting grout. For tests on individual steel H-piles, the test plate shall be welded to the pile. For tests on individual timber piles, the test plate may be set directly on the top of the pile which shall be sawed off to provide full bearing for the test plate or, alternatively, the test plate may be set in high-strength quick-setting grout.

3.1.6 In 3.3 and 3.4, the hydraulic jack(s) shall be centered on the test plate(s) with a steel bearing plate of adequate thickness between the top(s) of the jack ram(s) and the bottom(s) of the test beam(s). If a load cell(s) or equivalent device(s) is to be used, it shall be centered on the bearing plate above the ram(s) with another steel bearing plate of sufficient thickness between the load cell(s) or equivalent device(s) and the bottom(s) of the test beam(s). Bearing plates shall be of sufficient size to accommodate the jack ram(s) and the load cell(s) or equivalent device(s) and properly bear against the bottom(s) of the test beam(s).

3.1.7 In 3.5 for tests on pile groups a test plate may be used in accordance with the appropriate provisions of 3.1 or, alternatively, the test beam(s) may be set directly on the pile cap or the loading material applied directly on the cap. Test beam(s) set directly on the cap shall obtain full bearing using high-strength quick-setting grout, if necessary.

3.2 Testing Equipment:

3.2.1 Hydraulic jacks including their operation shall conform to ANSI B30.1.

3.2.2 Unless a calibrated load cell(s) is used, the complete jacking system including the hydraulic jack(s), hydraulic pump, and pressure gage shall be calibrated as a unit before each test or series of tests in a test program to an accuracy of not less than 5 % of the applied load. The hydraulic jack(s) shall be calibrated over its complete range of ram travel for increasing and decreasing applied loads. If two or more jacks are to be used to apply the test load, they shall be of the same ram diameter, connected to a common manifold and pressure gage, and operated by a single hydraulic pump.

NOTE 6—If it is not feasible to calibrate the complete jacking system as a unit, the pressure gage may be calibrated independently, in which case the jack piston(s) should be measured to verify the area(s).

3.2.3 When an accuracy greater than that obtainable with the jacking system is required, a properly constructed load cell(s) or equivalent device(s) shall be used in series with the hydraulic jack(s). Load cell(s) or equivalent device(s) shall be calibrated prior to the test to an accuracy of not less than 2 % of the applied load and shall be equipped with a spherical bearing(s).

3.2.4 If the hydraulic jack pump is to be left unattended at any time during the test, it shall be equipped with an automatic regulator to hold the load constant as pile settlement occurs.

3.2.5 Calibration reports shall be furnished for all testing equipment for which calibration is required, and shall show the temperature at which the calibration was done.

NOTE 7—Considerations should be given to employing a dual load-measuring system (gage and load cell) to provide as a check and as a back-up in case one system malfunctions. Hydraulic jack rams should have sufficient travel to provide for anticipated pile settlements, deflections of the test beam, and elongation of connections to anchoring devices with 3.3. The use of a single high-capacity jack is preferred to the use of multiple jack(s). If a multiple jacking system is used, each jack should be fitted with a pressure gage (in addition to the master gage) in order to detect malfunctions.

3.3 *Load Applied to Pile or Pile Group by Hydraulic Jack(s) Acting Against Anchored Reaction Frame* (See Figs. 1 and 2):

3.3.1 Install a sufficient number of anchor piles or suitable anchoring device(s) so as to provide adequate reactive capacity and a clear distance from the test pile or pile group at least five times the maximum diameter of the largest anchor or test pile(s) but not less than 7 ft (2 m). When testing individual batter piles, the anchor piles shall be battered in the same direction and angle as the test pile.

3.3.2 Center over the test pile or pile group a test beam(s) of sufficient size and strength to avoid excessive deflection under load with sufficient clearance between the bottom flange(s) of the test beam(s) and the top of the test pile or pile group to provide for the necessary bearing plates, hydraulic jack(s) (and load cell(s) if used). When applying axial loads to an individual batter pile, the test beam(s) should be oriented perpendicular to the direction of batter. For test loads of high magnitude requiring several anchors, a steel framework may be required to transfer the applied loads from the test beam(s) to the anchors.

3.3.3 Attach the test beam(s) (or reaction framework if used) to the anchoring devices with connections designed to

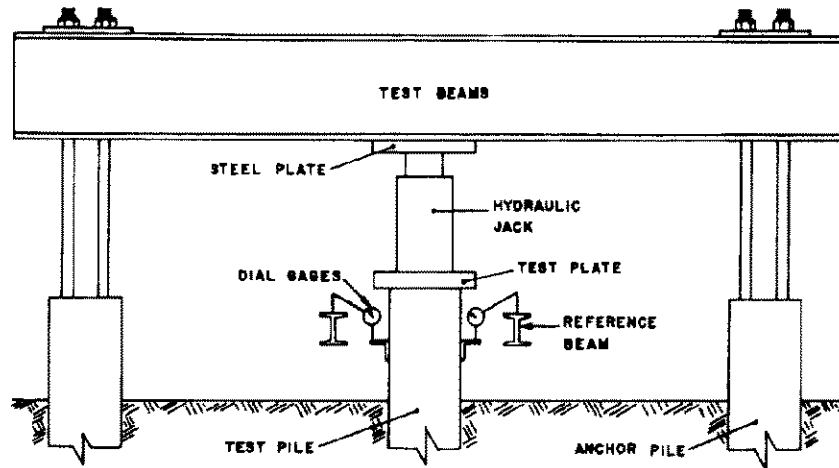
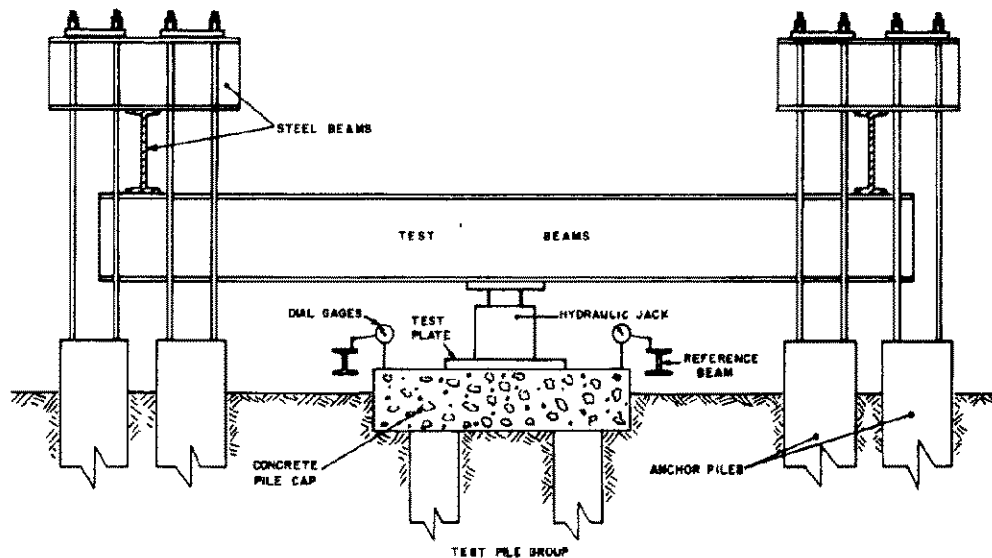

FIG. 1 Schematic Set-Up for Applying Loads to Pile Using Hydraulic Jack Acting Against Anchored Reaction Frame



Methods shown in Figs. 3 and 4 could be used.

FIG. 2 Typical Arrangement for Applying Load Test to Pile Group Using Method Illustrated in Fig. 1

adequately transfer the applied loads to the anchors so as to prevent slippage, rupture or excessive elongation of the connections under maximum required test load.

3.3.4 Apply the test load in accordance with the standard loading procedure 5.1 or as otherwise specified to the test pile or pile group with the hydraulic jack(s) reacting against the test beam(s).

3.4 Load Applied to Pile or Pile Group by Hydraulic Jack(s) Acting Against a Weighted Box or Platform (See Fig. 3):

3.4.1 Center over the test pile or pile group a test beam(s) of sufficient size and strength to avoid excessive deflection under load allowing sufficient clearance between the top of the test pile or pile cap and the bottom(s) of the beam(s) after deflection under load to accommodate the necessary bearing plates, hydraulic jack(s) (and load cell(s) if used). Support the

ends of the test beam(s) on temporary cribbing or other devices.

3.4.2 Center a box or platform on the test beam(s) with the edges of the box or platform parallel to the test beam(s) supported by cribbing or piles placed as far from the test pile or pile group as practicable but in no case less than a clear distance of 5 ft (1.5 m). If cribbing is used, the bearing area of the cribbing at ground surface shall be sufficient to prevent adverse settlement of the weighted box or platform.

3.4.3 Load the box or platform with any suitable material such as soil, rock, concrete, steel, or water-filled tanks with a total weight (including that of the test beam(s) and the box or platform) at least 10 % greater than the anticipated maximum test load.

3.4.4 Apply the test loads to the pile or pile group in accordance with the standard procedure in 5.1 or as other-

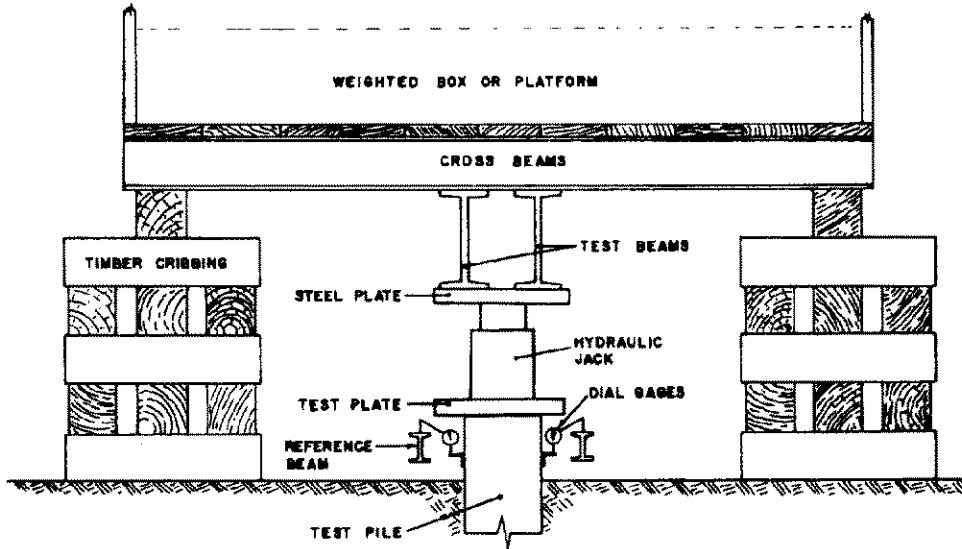

FIG. 3 Schematic Set-Up for Applying Loads to Pile Using Hydraulic Jack Acting Against Weighted Box or Platform

wise specified with the hydraulic jack(s) reacting against the test beam(s).

3.5 Load Applied Directly to the Pile or Pile Group with Known Weights (See Figs. 4, 5, and 6):

3.5.1 Center on the test plate or pile cap a test beam(s) of known weight and of sufficient size and strength to avoid excessive deflection under load with the ends supported on temporary cribbing if necessary to stabilize the beam(s). Alternatively the known test weights or loading material may be applied directly on the pile or pile cap.

3.5.2 Center and balance a platform of known weight on the test beam(s) or directly on the pile cap with overhanging edges of the platform parallel to the test beam(s) supported by cribbing or by piles capped with timber beams, so that a clear distance of not less than 5 ft. (1.5 m) is maintained between the supports and the test pile or pile group.

3.5.3 Place sufficient pairs of timber wedges between the top of the cribbing or timber cap beams and the bottom

edges of the platform so that the platform can be stabilized during loading or unloading.

3.5.4 When ready to load the platform, remove any temporary supports at the ends of the test beam(s) and tighten the wedges along the bottom edges of the platform so that the platform is stable. Load the platform in accordance with the standard loading procedures in 5.1 or as otherwise specified using material such as steel or concrete so that the weight of incremental loads can be determined within 5 %.

NOTE 8—With the loading apparatus described in 3.5, provisions can be made for taking target rod level readings directly on the center of the pile butt or pile cap or center of the test plate to measure pile butt movements in 4.2.3. For tests on concrete piles, or on pile groups, a hole would be required in the center of the test plate through which would extend a steel pin embedded in the top of the pile or pile cap. For tests on steel H or timber piles, readings would be taken on the test plate. To accommodate the target rod, a double test beam must be used with sufficient space between the beams and a hole must be left through the platform. To permit sighting on the target rod it may be necessary to leave a space between the test weights in line with the line of sight.

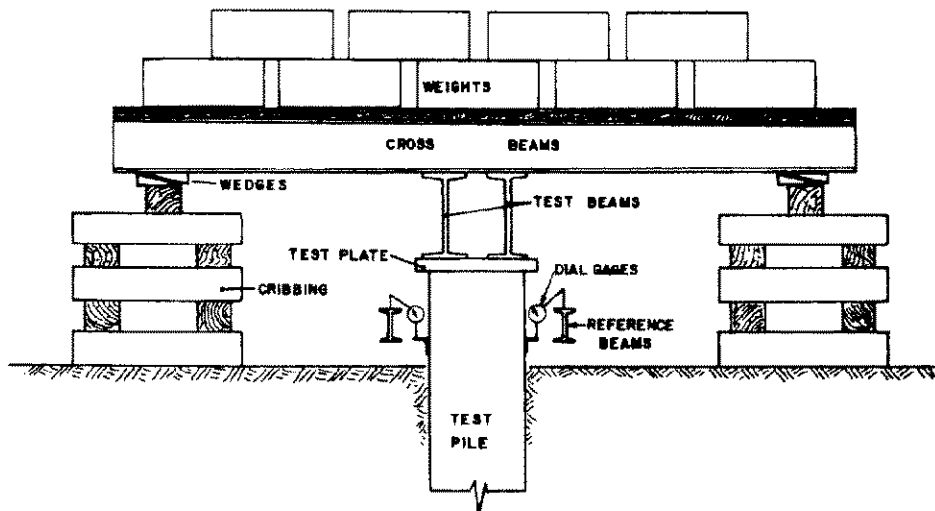

FIG. 4 Schematic Set-Up for Applying Loads Directly to Pile Using Weighted Platform

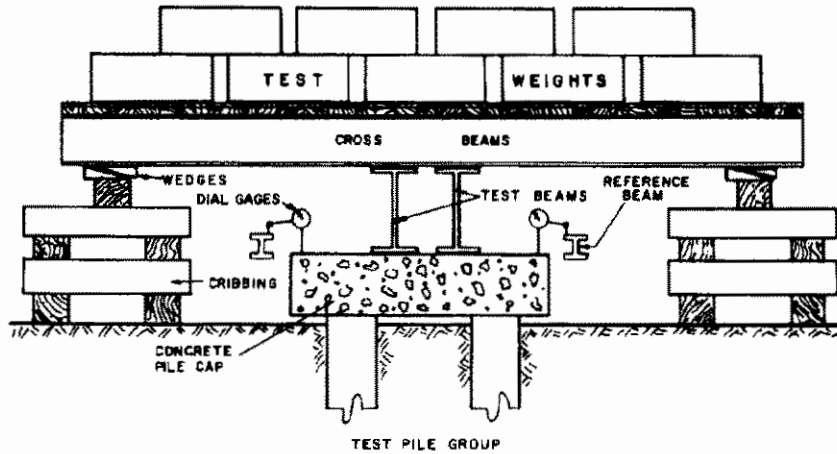

FIG. 5 Possible Arrangement for Applying Load Test to Pile Group Using Weighted Platform

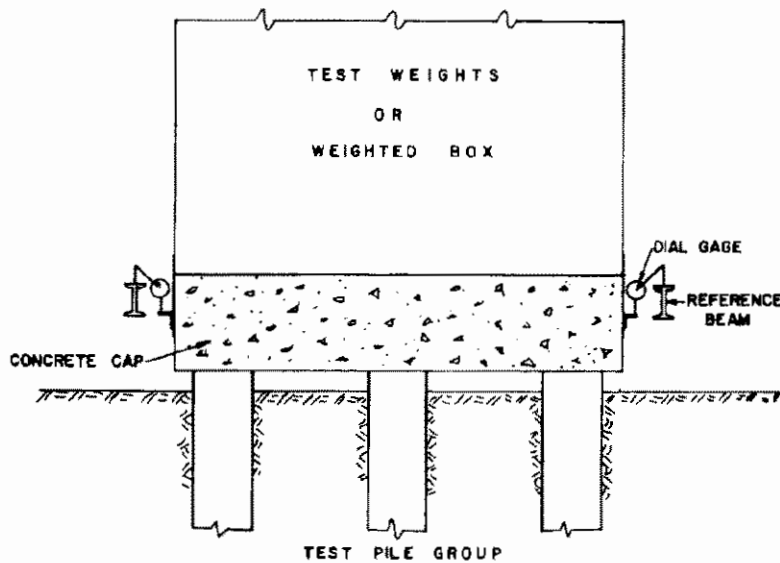

FIG. 6 Arrangement for Applying Tests Loads Directly on Pile Cap for Group Tests

3.6 *Other Types of Loading Apparatus* (Optional)—Any other type of loading apparatus satisfying the basic requirements of 3.3 or 3.4 may be used.

4. Apparatus for Measuring Movement

4.1 *General:*

4.1.1 All reference beams and wires shall be independently supported with supports firmly embedded in the ground at a clear distance of not less than 8 ft (2.5 m) from the test pile or pile group and as far as practical from the anchor piles or cribbing. Reference beams shall be sufficiently stiff to support the instrumentation such that excessive variations in readings do not occur and should be cross connected to provide additional rigidity. If steel reference beams are used, one end of each beam shall be free to move horizontally as the beam length changes with temperature variations.

4.1.2 Dial gages shall have at least a 2-in. (50-mm) travel; longer gage stems or sufficient gage blocks shall be provided to allow for greater travel if anticipated. Except as required in

4.4.2, gages shall have a precision of at least 0.01 in. (0.25 mm). Smooth bearing surfaces (such as glass) perpendicular to the direction of gage-stem travel shall be provided for the gage stems. Scales used to measure pile movements shall read to 1/64th of an inch or to 0.01 in. (0.25 mm). Target rods shall read to 0.001 ft (0.3 mm).

4.1.3 All dial gages, scales and reference points shall be clearly marked with a reference number or letter to assist in recording data accurately. Provisions shall be made to protect the measuring system, reference system, and instrumentation from adverse temperature variations and from disturbance. All gages, scales, or reference points attached to the test pile or pile cap shall be mounted so as to prevent movement relative to the test pile or pile cap during the test.

4.2 *Pile Butt Axial Movements* (See Fig. 7)—The apparatus for measuring axial movement of the butt of the test pile or piles within the group shall consist of a primary and secondary system in accordance with the following methods.

NOTE 9—Two separate measuring systems are required in order to have a check on the observed data, to provide for accidental disturbance

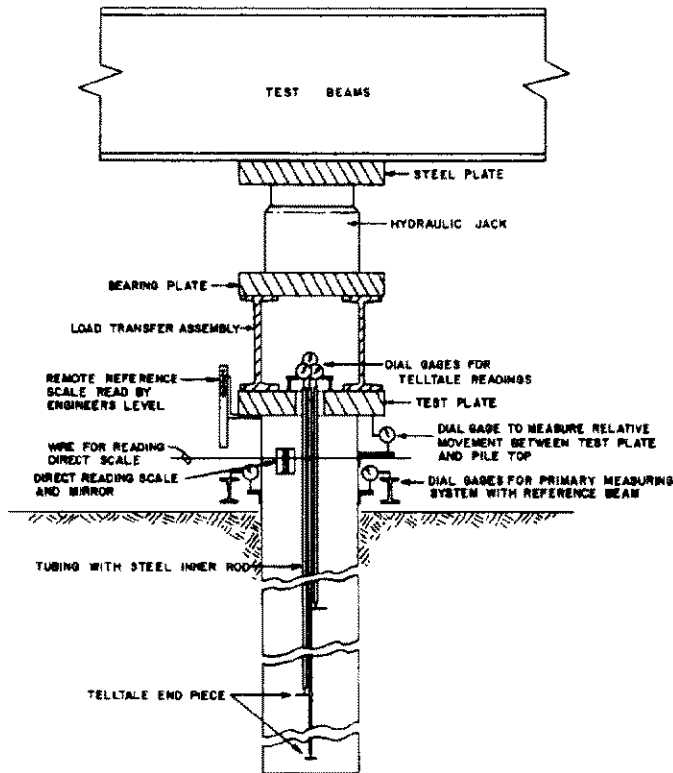

FIG. 7 Possible Arrangement of Instrumentation for Measuring Vertical Movements of Pile

of the measuring system, and to permit continuity of data in case it becomes necessary to reset the gages or scales.

4.2.1 Dial Gages—Two parallel reference beams, one on each side of the test pile or pile cap, shall be oriented in a direction that permits placing their supports as far as practicable from anchor piles or cribbing. A minimum of two dial gages shall be mounted on the reference beams approximately equidistant from the center of and on opposite sides of the test pile or pile cap with stems parallel to the longitudinal axis of the pile(s) and bearing on lugs firmly attached to the sides of the pile or pile cap below the test plate. Alternatively, the two dial gages shall be mounted on opposite sides of the test pile or pile cap below the test plate with stems parallel to the longitudinal axis of the pile(s) and bearing on lugs firmly attached to the reference beams. However, gages may be mounted to bear on the top of the pile cap or on the test plate provided that two additional gages shall be mounted on opposite sides of the test plate to measure relative movements between the test plate and the pile or pile cap (see Fig. 7). For tests on individual batter piles, the dial gages shall be mounted along a line perpendicular to the direction of batter.

NOTE 10—The use of four dial gages mounted 90° apart is recommended to compensate for lateral movement or rotation of the pile butt due to accidental eccentric loading.

NOTE 11—For tests on batter piles, it is recommended that a dial gage be mounted in line with the direction of batter through the center of the test pile with the gage stem perpendicular to the longitudinal axis of the pile and bearing against a lubricated glass plate to measure lateral movements.

4.2.2 Wire, Mirror, and Scale—Two parallel wires, one on each side of the test pile or pile cap, shall be oriented in a direction that permits placing the wire supports as far as practicable from anchor piles or cribbing. Each wire shall pass across and be clear of the face of a scale that is mounted parallel to the axis of the test pile or piles within the group and that is attached to a mirror fixed to the test pile or pile cap so that consistent readings of axial movement can be made directly from the scale by lining up the wire and its image in the mirror. The wire shall be not more than 1 in. (25 mm) from the face of the scale. A suitable method shall be used to maintain tension in the wires throughout the test so that when plucked or tapped, the wire will return to its original position. Piano wire or equivalent type shall be used.

4.2.3 Surveyor's Level or Laser Beam—Readings using a surveyor's level or laser beam shall be taken on a target rod or a scale and shall be referenced to a permanent bench mark located outside of the immediate test area or, alternatively, the surveyor's level shall be mounted on an object of fixed elevation (for example a driven pile) outside of the immediate test area. Reference points or scales used in taking settlement readings shall be mounted on the sides of the test pile or pile cap and located on opposite sides except that reference points may be on top of the pile cap or readings may be taken on a single fixed point in the center of the test pile top, test plate or pile cap or on scales mounted on the test plate provided that relative movements between the test plate and the top of the pile are measured in accordance with 4.2.1 (see Fig. 7).

4.2.4 Other Types of Measuring Apparatus (Optional)—Any other type of measuring device such as electric or optical gages of proven reliability and that yield an accuracy of 0.01 in. (0.25 mm) may be used.

4.3 Lateral Movements (Optional)—The lateral movements of the top of the test pile or pile group shall be measured to an accuracy of 0.1 in. (2.5 mm) using either of the following methods: (a) two dial gages mounted on the reference beam 90° apart with their stems perpendicular to the longitudinal axis of the test pile(s) and bearing against the sides of the test pile or pile cap, or (b) an engineer's transit reading from fixed positions scales mounted horizontally on the sides of the test pile or pile cap 90° apart with readings referenced to fixed foresights or backsights. For tests on batter piles, one of the gages or scales shall be oriented in the direction of the batter.

4.4 Incremental Strain Measurements (Optional):

4.4.1 The test pile(s) shall be instrumented as specified to determine distribution of load transfer from the pile to the soil. If strain rods or telltales (see Figs. 7, 8, 9, and 10) are used, they shall be installed in or on the test pile terminating at the pile tip and at other points along the pile as required and shall be sheathed or encased to insure free movement of the rods during the test. The influence of the sheathing on the elastic properties of the pile section shall be considered. If electric resistant strain gages are used, the gage type and installation shall be as specified and shall include temperature compensating gages.

NOTE 12—Where feasible, measurement programs involving strain gages should include calibration of the fully instrumented pile and a complete strain history starting before the pile is installed.

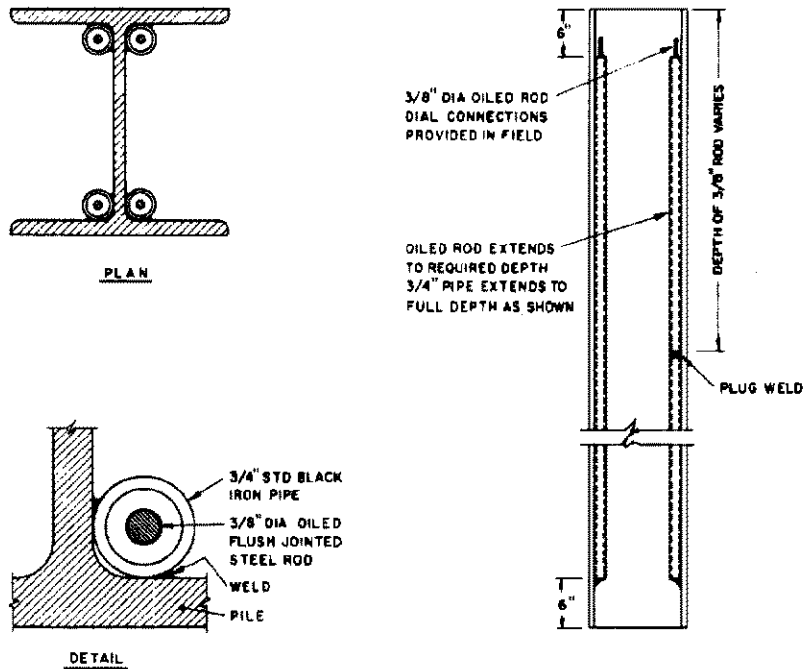

FIG. 8 Possible Installation of Telltales for Steel H-Piles

4.4.2 Pile butt axial movements shall be measured with dial gages (see 4.2.1). The movements of the top of each strain rod relative to the top of the test pile shall be measured with a dial gage reading to 0.001 in. (0.025 mm). Dial gages shall be referenced to points on the test pile below the test plate except that they may be referenced to the top of the test plate if the plate is welded to the pile or if relative movements between the top of the test pile and the test plate are measured in accordance with 4.2.1 (see Fig. 7).

5. Loading Procedures

5.1 *Standard Loading Procedure*—Unless failure occurs first, load the pile to 200 % of the anticipated pile design load for tests on individual piles or to 150 % of the group design

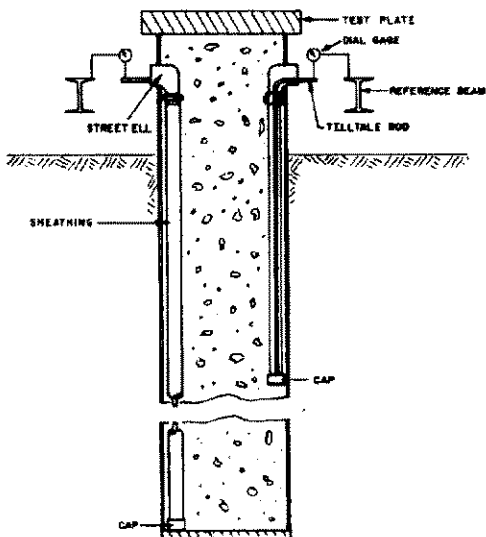

FIG. 9 Possible Installation of Telltales for Pipe Piles

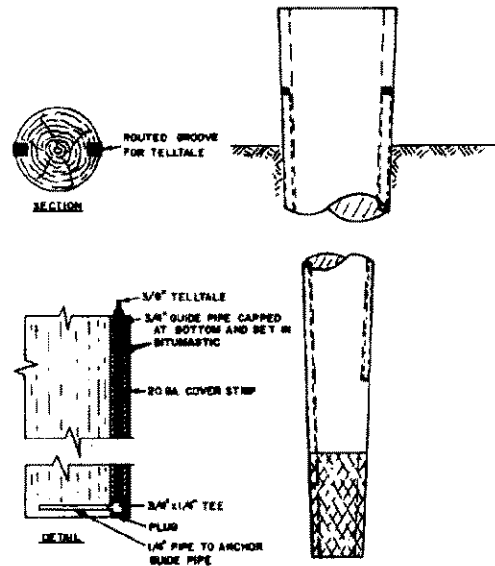

FIG. 10 Possible Installation of Telltales for Timber Piles

load for tests on pile groups, applying the load in increments of 25 % of the individual pile or group design load. Maintain each load increment until the rate of settlement is not greater than 0.01 in. (0.25 mm)/h but not longer than 2 h. Provided that the test pile or pile group has not failed, remove the total test load anytime after 12 h if the butt settlement over a one-hour period is not greater than 0.01 in. (0.25 mm); otherwise allow the total load to remain on the pile or pile group for 24 h. After the required holding time, remove the test load in decrements of 25 % of the total test load with 1 h between decrements. If pile failure occurs continue jacking

the pile until the settlement equals 15 % of the pile diameter or diagonal dimension.

5.1.1 *Direct Loading Method*—When using the loading method described in 3.5, include in the first load increment the weight of the test beam(s) and the platform. Before adding or removing load increments, tighten the wedges along the platform edges to stabilize the platform. Place or remove load increments in a manner which avoids impact and maintains the load balanced at all times. After each load increment has been added, loosen (but do not remove) the wedges and keep them loose to permit the full load to act on the pile as settlement occurs.

NOTE 13—Testing a pile to failure provides valuable information to the design engineer and is recommended for pile tests performed prior to the foundation design or to evaluate comparative performances of different type piles. Such testing permits the selection of optimum pile type and design load.

NOTE 14—If the test pile(s) may exhibit or has exhibited negligible settlement at the design load or may approach or has approached incipient failure at the full test load, consideration may be given to increasing the standard loading increments at the start of the test or subsequent tests or to decreasing the standard loading increments during the latter stages of the test or subsequent tests.

5.2 *Cyclic Loading (Optional)*—For the first application of test load increments, apply such increments in accordance with 5.1. After the application of loads equal to 50, 100, and 150 % of the pile design load for tests on individual piles or 50 and 100 % of the group design load for tests on pile groups, maintain the total load in each case for 1 h and remove the applied load in decrements equal to the loading increments, allowing 20 min between decrements. After removing each total applied load, reapply the load to each preceding load level in increments equal to 50 % of the design load, allowing 20 min between increments. Apply additional loads in accordance with 5.1. After the total required test load has been applied, hold and remove the test load in accordance with 5.1.

5.3 *Loading in Excess of Standard Test Load (Optional)*—After the load has been applied and removed in accordance with 5.1, reload the test pile or pile group to the standard test load in increments of 50 % of the pile or pile group design load, allowing 20 min between load increments. Then increase the load in increments of 10 % of the design load for the pile or pile group until the maximum required load has been applied or until failure of the test pile or pile group occurs, allowing 20 min between load increments. If failure does not occur, hold the full load for 2 h and then remove the load in four equal decrements, allowing 20 min between decrements.

5.4 *Constant Time Interval Loading (Optional)*—Follow the procedures of 5.1 except apply load in increments of 20 % of the pile or group design load with 1 h between load increments and unload the piles with 1 h between load decrements.

5.5 *Constant Rate of Penetration Method for Individual Piles (Optional)*:

5.5.1 The apparatus for applying loads shall have a capacity as specified and shall be in accordance with either 3.3 or 3.4. The hydraulic jack ram(s) shall have a travel greater than the anticipated total movement of the pile but not less than 25 % of the average pile diameter or diagonal dimension. A mechanical pump equipped with a bleed valve,

variable speed device, or other means for providing a smooth variable delivery shall be used. If a video recording system is used to record the test data, a digital clock reading to seconds should be used and the clock as well as all gages shall be easily readable and located within the camera field.

5.5.2 Vary the applied load as necessary to maintain a pile penetration rate of 0.01 to 0.05 in. (0.25 to 1.25 mm)/min for cohesive soil or 0.03 to 0.10 in. (0.75 to 2.5 mm)/min for granular soils, or as otherwise specified. Continue loading the pile until no further increase in the load is necessary for continuous pile penetration at the specified rate unless the specified capacity of the loading apparatus is reached. If pile penetration continues, hold the load required to achieve the specified penetration rate until the total pile penetration is at least 15 % of the average pile diameter or diagonal dimension at which time release the load. If the pile stops penetrating under the maximum applied load, release the load.

5.5.3 The rate of penetration may be controlled by checking the time taken for successive small equal increments of penetration and by adjusting the rate of jacking accordingly. Alternatively, any mechanical or electrical device may be used to monitor and control the penetration rate so that it remains constant.

5.5.4 See 6.3 for measurement procedures.

5.6 *Quick Load Test Method for Individual Piles (Optional)*:

5.6.1 The apparatus for applying the load shall have a capacity as specified and shall be in accordance with 3.3 or 3.4.

5.6.2 Apply the load in increments of 10 to 15 % of the proposed design load with a constant time interval between increments of 2½ min or as otherwise specified. Add load increments until continuous jacking is required to maintain the test load or until the specified capacity of the loading apparatus is reached, whichever occurs first, at which time stop the jacking. After a 5-min interval or as otherwise specified, remove the full load from the pile.

5.6.3 See 6.4 for measurement procedures.

NOTE 15—For 5.5 and 5.6 it is recommended that the full test load be removed in four approximately equal decrements with 5 min between decrements so the shape of the rebound curve may be determined.

5.7 *Constant Settlement Increment Loading Method for Individual Piles (Optional)*:

5.7.1 The apparatus for applying the load shall have a capacity as specified and shall be in accordance with 3.3 or 3.4.

5.7.2 Apply test loads in increments required to produce pile butt settlement increments equal to approximately 1 % of the average pile diameter or diagonal dimension. Vary the applied load as necessary to maintain each settlement increment, and do not apply additional load until the rate of load variation to hold that settlement increment constant is less than 1 % of the total applied load per hour. Continue loading the pile in such increments until the total butt settlement equals about 10 % of the average pile diameter or diagonal dimensions or until the specified capacity of the loading apparatus is reached.

5.7.3 Remove the full test load in four equal decrements after maintaining the final settlement increment until the

rate of load variation is less than 1 % of the total applied load per hour. After removing the first load decrement, do not remove additional decrements until the rate of pile rebound for the preceding load decrement is less than 0.3 % of the average pile diameter or diagonal dimension per hour.

5.7.4 See 6.5 for measurement procedures.

NOTE 16—For piles driven into cohesive soils, the elapsed time between driving and testing should be sufficient to allow dissipation of any excess pore water pressure resulting from pile driving and to permit the regain of the soil strength (known as soil freeze). The waiting period will depend on such things as the amount of excess pore water pressure built up, the degree of soil structure disturbance resulting from pile driving, and the soil properties. It could range from a minimum of 3 days to as long as 30 days or longer and the actual required waiting period may be determined by testing (for example redriving piles) or by prior experience.

NOTE 17—To avoid excessive creep of green concrete in cast-in-place concrete piles, the elapsed time between concrete placement and pile testing should be sufficient to permit the concrete to cure and harden properly, recognizing that the curing time for the concrete in the pile generally will be longer than that for the sampled concrete in standard test cylinders.

6. Procedures for Measuring Pile Movements

6.1 General—For axial movements, take readings on the test pile or pile cap; readings may be taken on the test plate, provided that the requirements of 4.2.1 are satisfied. For lateral movements, taken readings on the sides of the test pile or pile cap. Take required readings at each properly identified gage, scale, or reference point as nearly simultaneously as practicable. When using the loading method described in 3.5, take the no-load reading before the test beam(s) and platform are permitted to bear on the pile(s). Clearly indicate and explain any adjustments made to instrumentation or to data recorded in the field.

6.2 Standard Measuring Procedures—Take readings of time, load, and movement, and record them before and after the application of each load increment or the removal of each load decrement. During loading, provided that the test pile or pile group has not failed, take additional readings and record them at intervals not exceeding 10 min during the first ½ h nor 20 min thereafter for each load increment. After the total load has been applied, provided that the test pile or pile group has not failed, take readings and record at intervals not exceeding 20 min during the first 2 h, not exceeding 1 h for the next 10 h, and not exceeding 2 h for the next 12 h. If pile failure occurs, take readings immediately before removing the first load decrement. During unloading, take readings and record at intervals not exceeding 20 min. Take a final rebound reading 12 h after all load has been removed.

NOTE 18—If incremental strain measurements as in 4.4 are made using strain gages, gage readings should be taken and recorded before and after the pile is installed and immediately before the application of test loads so that a complete strain history is obtained and residual stresses can be accounted for.

6.3 Readings for Constant Rate of Penetration Loading—Take readings of time, load, and settlement, and record at least every 30 s or at sufficient intervals to determine the rate of penetration being achieved. If automatic monitoring and recording devices are used, operate them continuously during each test. When the test pile has achieved its specified rate of penetration, continue to take and record readings for

the duration of the loading, and determine the maximum load applied. Immediately after unloading, take and record readings of time, load, and rebound. Take final readings and record 1 h after all load has been removed.

6.4 Readings for Quick Load Test Method—Take readings of time, load, and settlement, and record immediately before and after the application of each load increment and at intermediate time intervals as specified. When the maximum load has been applied, take readings and record when the jacking is stopped. Repeat after 2½ min and again at 5 min thereafter. If a longer holding period than in 5.7.2 is specified, take and record additional readings as specified. Take readings of time and rebound, and record after all load has been removed. Repeat after 2½ min and again at 5 min thereafter.

6.5 Readings for Constant Settlement Increment Method—Take readings of time, load, and settlement, and record immediately before and after each settlement increment with sufficient intermediate readings so as to determine the rate of load variation and the actual load required to maintain each settlement increment. During unloading, take readings of time, load, and rebound, and record immediately before and after the removal of each load decrement with sufficient intermediate readings so as to determine the rate of pile rebound. Take final readings and record 12 h after all load has been removed.

NOTE 19—Level readings should be taken on the reference beams and on the reaction system using a surveyor's level or transit and target rod or scale to determine if any excessive movement occurs. Such readings should be taken and recorded before any test load is applied, at the proposed design load, at the maximum test load, and after all load has been removed. Intermediate readings may be required if results during testing appear unusual.

NOTE 20—When testing piles in granular soils in dewatered excavations which will be submerged during service, the groundwater level should be maintained as near to the existing ground surface as possible and the depth to the groundwater level should be measured and recorded during the test. If the groundwater level during the test is more than 5 ft (1.5 m) below the ground surface, a correction to the pile bearing capacity as determined by the test should be made.

7. Safety Requirements

7.1 All operations in connection with pile load testing shall be carried out in such a manner so as to minimize, avoid, or eliminate the exposure of people to hazard. The following safety rules are in addition to general safety requirements applicable to construction operations:

7.1.1 All work areas, walkways, platforms, etc., shall be kept clear of scrap, debris, small tools, and accumulations of snow, ice, mud, grease, oil, or other slippery substances.

7.1.2 All timbers, blocking and cribbing materials shall be of quality material and be in good serviceable condition with flat surfaces and without rounded edges.

7.1.3 Hydraulic jacks shall be equipped with spherical bearing plates or shall be in complete and firm contact with the bearing surfaces and shall be aligned so as to avoid eccentric loading.

7.1.4 Loads shall not be hoisted, swung, or suspended over anyone and shall be controlled by tag lines.

7.1.5 The attachments of the test beam(s) or reaction frame to the anchor piles or other anchoring devices shall be designed and installed to transmit the required loads with an adequate factor of safety.

7.1.6 For tests on batter piles, all inclined jacks, bearing plates, test beam(s), or frame members shall be firmly fixed into place or adequately blocked to prevent slippage upon release of load.

7.1.7 All reaction loads shall be stable and balanced. When using loading method in 3.5, safety wedges shall be in place at all times to prevent the platform from tipping. During testing, movements of the reaction load or system should be monitored to detect impending unstable conditions.

7.1.8 All test beams, reaction frames, platforms, and boxes shall be adequately supported at all times.

7.1.9 Only authorized personnel shall be permitted within the immediate test area.

8. Report

8.1 The report of the load test shall include the following information when applicable:

- 8.1.1 *General:*
 - 8.1.1.1 Project identification,
 - 8.1.1.2 Project location,
 - 8.1.1.3 Test site location,
 - 8.1.1.4 Owner,
 - 8.1.1.5 Structural engineer,
 - 8.1.1.6 Geotechnical engineer,
 - 8.1.1.7 Pile contractor,
 - 8.1.1.8 Test boring contractor,
 - 8.1.1.9 Designation and location of nearest test boring with reference to test pile or group,
 - 8.1.1.10 Log of nearest test boring,
 - 8.1.1.11 Horizontal control datum, and
 - 8.1.1.12 Vertical control (elevation) datum.
- 8.1.2 *Pile Installation Equipment:*
 - 8.1.2.1 Make, model, type and size of hammer,
 - 8.1.2.2 Weight of hammer and ram,
 - 8.1.2.3 Stroke or ram,
 - 8.1.2.4 Rated energy of hammer,
 - 8.1.2.5 Rated capacity of boiler or compressor,
 - 8.1.2.6 Type and dimensions of capblock and pile cushion,
 - 8.1.2.7 Weight and dimensions of drive cap and follower,
 - 8.1.2.8 Size of predrilling or jetting equipment,
 - 8.1.2.9 Weight of clamp, follower, adaptor, and oscillator for vibratory driver.
 - 8.1.2.10 Type, size, length, and weight of mandrel,
 - 8.1.2.11 Type, size, and length of auger,
 - 8.1.2.12 Type and size of grout pump, and
 - 8.1.2.13 Type, size, wall thickness, and length of drive casing.
- 8.1.3 *Test and Anchor Piles:*
 - 8.1.3.1 Identification and location of test and anchor piles,
 - 8.1.3.2 Design load of pile or pile group,
 - 8.1.3.3 Type of pile(s)—test and anchor,
 - 8.1.3.4 Test pile material including basic specifications,
 - 8.1.3.5 Tip and butt dimensions of pile(s),
 - 8.1.3.6 General quality of timber test piles including occurrence of knots, splits, checks and shakes, and straightness of piles,
 - 8.1.3.7 Preservative treatment and conditioning process used for timber test piles including inspection certificates,

- 8.1.3.8 Wall thickness of pipe test pile,
- 8.1.3.9 Weight per foot of H test pile,
- 8.1.3.10 Description of test pile tip reinforcement or protection,
- 8.1.3.11 Description of banding—timber piles,
- 8.1.3.12 Description of special coatings used,
- 8.1.3.13 Test pile (mandrel) weight as driven,
- 8.1.3.14 Date precast test piles made,
- 8.1.3.15 Concrete cylinder strengths when test pile driven and when pile tested (approximate),
- 8.1.3.16 Description of internal reinforcement used in test pile (size, length, number longitudinal bars, arrangement, spiral, or tie steel),
- 8.1.3.17 Condition of precast piles including spalled areas, cracks, head surface, and straightness of piles.
- 8.1.3.18 Effective prestress,
- 8.1.3.19 Which piles vertical or batter,
- 8.1.3.20 Degree of batter,
- 8.1.3.21 Length of test pile during driving,
- 8.1.3.22 Embedded length—test and anchor piles,
- 8.1.3.23 Tested length of test pile, and
- 8.1.3.24 Final elevation of test pile butt(s) referenced to fixed datum.
- 8.1.4 *Pile Installation—Test and Anchor:*
 - 8.1.4.1 Date driven (installed),
 - 8.1.4.2 Date concreted (cast-in-place),
 - 8.1.4.3 Volume of concrete or grout placed in pile,
 - 8.1.4.4 Grout pressure used,
 - 8.1.4.5 Description of pre-excitation or jetting (depth, size, pressure, duration),
 - 8.1.4.6 Operating pressure for double-acting and differential type hammers,
 - 8.1.4.7 Throttle setting—diesel hammer (at final driving),
 - 8.1.4.8 Fuel type—diesel hammer,
 - 8.1.4.9 Horsepower delivered and frequency of vibratory driver during final 10 ft (3 m) of pile penetration,
 - 8.1.4.10 Description of special installation procedures used such as piles cased off,
 - 8.1.4.11 Type and location of pile splices,
 - 8.1.4.12 Driving logs (blows per foot),
 - 8.1.4.13 Final penetration resistance (blows per inch),
 - 8.1.4.14 Rate of pile penetration for last 10 ft (3 m) s/ft, vibratory driving,
 - 8.1.4.15 When capblock replaced (indicate on log),
 - 8.1.4.16 When pile cushion replaced (indicate on log),
 - 8.1.4.17 Cause and duration of interruptions in pile installation, and
 - 8.1.4.18 Notation of any unusual occurrences during installation.
- 8.1.5 *Pile Testing:*
 - 8.1.5.1 Date tested,
 - 8.1.5.2 Type test,
 - 8.1.5.3 Number of piles in group test,
 - 8.1.5.4 Brief description of load application apparatus, including jack capacity,
 - 8.1.5.5 Description of instrumentation used to measure pile movement including location of gages or other reference points with respect to pile butt (see Note 21),
 - 8.1.5.6 Description of special instrumentation such as strain rods or gages including location of such with reference to pile butt,

- 8.1.5.7 Special testing procedures used,
- 8.1.5.8 Tabulation of all time, load, and movement readings,
- 8.1.5.9 Identification and location sketch of all gages, scales, and reference points (see Note 21),
- 8.1.5.10 Description and explanation of adjustments made to instrumentation or field data, or both,
- 8.1.5.11 Notation of any unusual occurrences during testing,
- 8.1.5.12 Test jack and other required calibration reports,
- 8.1.5.13 Groundwater level (see Note 20), and
- 8.1.5.14 Temperature and weather conditions during tests.

NOTE 21—Suitable photographs can be very helpful in showing the instrumentation set-up, location of gages, scales, and reference points.

NOTE 22—In addition to the above required information to be reported, the results of any in-place and laboratory soil tests should be made available for the proper evaluation of test results.

9. Precision and Bias

9.1 *Precision*—Data are being evaluated to determine the precision of this test method. In addition, Subcommittee D18.11 is seeking pertinent data from users of this test method.

9.2 *Bias*—A statement on bias is not possible because there are no standard reference materials.

10. Keywords

10.1 field testing; load cell; loading procedure; piles; reference beam

APPENDIX

(Nonmandatory Information)

X1. SOME FACTORS INFLUENCING INTERPRETATION OF TEST RESULTS

X1.1 Potential residual loads in the pile which could influence the interpreted distribution of load at the pile tip and along the pile shaft.

X1.2 Possible interaction of friction loads from test pile with upward friction transferred to the soil from anchor piles obtaining part or all of their support in soil at levels above the tip level of the test pile.

X1.3 Changes in pore water pressure in the soil caused by pile driving, construction fill, and other construction operations which may influence the test results for frictional support in relatively impervious soils such as clay and silt.

X1.4 Differences between conditions at time of testing and after final construction such as changes in grade or groundwater level.

X1.5 Potential loss of soil supporting test pile from such things as excavation and scour.

X1.6 Possible differences in the performance of a pile in a

group or of a pile group from that of a single isolated pile.

X1.7 Affect on long-term pile performance of factors such as creep, environmental effects on pile material, negative friction loads not previously accounted for, and strength losses.

X1.8 Type of structure to be supported, including sensitivity of structure to settlements and relation between live and dead loads.

X1.9 Special testing procedures which may be required for the application of certain acceptance criteria or methods of interpretation.

X1.10 Requirement that all conditions for nontested piles be basically identical to those for test pile including such things as subsurface conditions, pile type, length, size and stiffness, and pile installation methods and equipment so that application or extrapolation of the test results to such other piles is valid.

The American Society for Testing and Materials takes no position respecting the validity of any patent rights asserted in connection with any item mentioned in this standard. Users of this standard are expressly advised that determination of the validity of any such patent rights, and the risk of infringement of such rights, are entirely their own responsibility.

This standard is subject to revision at any time by the responsible technical committee and must be reviewed every five years and if not revised, either reapproved or withdrawn. Your comments are invited either for revision of this standard or for additional standards and should be addressed to ASTM Headquarters. Your comments will receive careful consideration at a meeting of the responsible technical committee, which you may attend. If you feel that your comments have not received a fair hearing you should make your views known to the ASTM Committee on Standards, 1916 Race St., Philadelphia, PA 19103.