

January 12, 1971

DESIGN NOTE NO. 11*

Subject: Welding Reinforcing Steel for Reinforced Concrete

Welding of reinforcing bars usually is not necessary in SCS construction and generally should be avoided, unless the saving in other construction costs is sufficient to balance the cost of the control that must be exercised to insure good welds. If a substantial number of large bars, #11 or larger, are to be spliced and there is not room for the required lap to develop the bar strength in bond, welding may be necessary. However, it usually is more economical, and better structurally, to increase the wall thickness and use smaller bars which can be lapped. Therefore, generally speaking, the use of #11 or larger bars is not recommended.

Tack welding of reinforcing bars in lieu of wire tying to hold them in place is not permitted by SCS standard specifications. Bars can be seriously weakened by tack welding.

Steel Composition

The standard specifications for reinforcing bars referred to in Material Specification 539, (ASTM A 615, A 616, and A 617) are based on physical properties and do not specify the chemical composition of the steel. Since weldability is dependent upon chemical composition, bars may conform to these specifications yet not be weldable. If bar splices are to be welded, Material Specification 539 still applies, but the construction details must specify in addition that the bars be of weldable steel. The contractor should be required to provide a certified copy of the mill test report showing the actual composition of the steel furnished.

Table I shows the ideal range of carbon and manganese in carbon steel for good weldability. Steels in the range indicated can be welded satisfactorily without special precautions. Preheating, low-hydrogen electrodes, or both, may be required to successfully arc-weld steel containing more than 0.30 percent carbon or more than 0.60 percent manganese. Oxyacetylene welding can be used for steels with somewhat higher carbon and manganese contents. Thermit welding can be used for steel having up to 0.80 percent carbon and 1.30 percent manganese.

*by A. S. Payne, Assistant Chief, Design Branch

Table I - Chemical Analysis of Carbon Steel
for Good Weldability

<u>Element</u>	<u>Range, %</u>
Carbon	.06 - .30
Manganese	.35 - .60
Silicon	.10 max.
Sulphur	.035 max.
Phosphorus	.030 max.

Welding Rods

Specifications for arc-welding electrodes and descriptions of the various classes and their intended uses are given in AWS A5.1, "Specification for Mild Steel Covered Arc-Welding Electrodes" of the American Welding Society (ASTM Designation: A233). Similar information for gas-welding rods is given in AWS A5.2, "Specification for Iron and Steel Gas-Welding Rods," (ASTM Designation: A251).

Welding Methods

The most common method of field welding is the shielded metal-arc method in which heat to fuse the metal is generated by an electric arc between the welding rod or electrode and the metal being welded. The electrode is a consumable metal rod coated with a material that gives off an inert gas to prevent contamination of the molten metal by the atmosphere.

Oxyacetylene gas welding, in which the welding heat is obtained by burning a mixture of acetylene and oxygen, also is used but is slower than electric-arc welding.

Both of these methods, performed by qualified welders, can produce welds of high quality in steels that are suitable for welding.

Thermit welding is a process in which the welding heat is generated by burning "thermit" powder. The essential ingredients of the powder are aluminum, iron oxide, and an igniting agent which react at high temperature to produce molten steel and alumina slag. Oxides of other elements are added to give the resulting weld metal the desired properties. In welding reinforcing bars by this process, the bars are clamped in position in a mold to which is attached a crucible containing the thermit powder. When the powder is ignited, the molten weld metal flows into the mold and between the ends of the bars. The bars and the weld metal are fused together. The process produces welds of good quality and can be used on steels that are hard to weld by other methods.

The thermit process can pose a serious fire hazard if not handled carefully. The molds and the powder must be protected from moisture, and the bar ends must be clean.

A patented process similar to thermit welding is "Cadweld" rebar splicing in which a metal sleeve is placed around the abutting bar ends and molten metal is cast into the space between the sleeve and the bars. The bars are not fused, however, so this is not a welded splice but depends upon mechanical interlocking of the cast metal with the deformations on the bars and with grooves on the inside of the sleeve.

Splice Design

The following provisions relating to welded splices in concrete reinforcement are contained in the ACI standard "Building Code Requirements for Reinforced Concrete" (ACI 318-63), section 805.

1. Splices in reinforcement in which the critical design stress is tensile -

"Lapped splices in tension shall not be used for bar sizes larger than #11."

"Splices at points of maximum tensile stress shall be avoided wherever possible; such splices where used shall be welded, lapped, or otherwise fully developed."

2. Splices in reinforcement in which the critical design stress is compressive -

"Welded splices or other positive connections may be used instead of lapped splices. Where the bar size exceeds #11, welded splices or other positive connections shall preferably be used. In bars required for compression only, the compressive stress may be transmitted by bearing of square-cut ends held in concentric contact by a suitably welded sleeve or mechanical device."

3. "An approved welded splice is one in which the bars are butted and welded so that it will develop in tension at least 125 percent of the specified yield strength of the reinforcing bar."

4. Welding shall conform to AWS D 12.1, "Recommended Practices for Welding Reinforcing Steel, Metal Inserts and Connections in Reinforced Concrete Construction."

Details of several types of welded splice are shown in Figure 1. Welded lap splices should not be used because of the eccentricity of load transfer through them and the resulting tendency to rupture the concrete. Double lap splices such as illustrated in Figure 1 may be used for small bars in tension or compression. The sleeve splice illustrated in Figure 1 is designed for column bars in compression. Butt splices are good for either tension or compression.

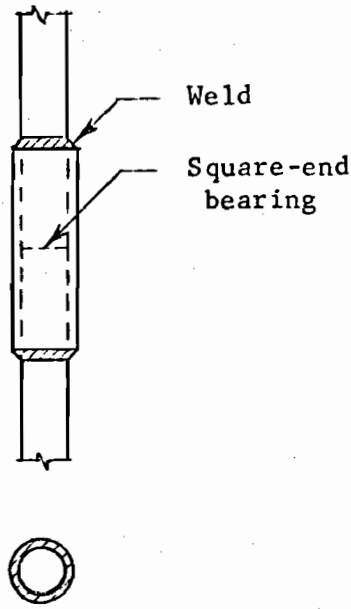

(a) SLEEVE SPLICE

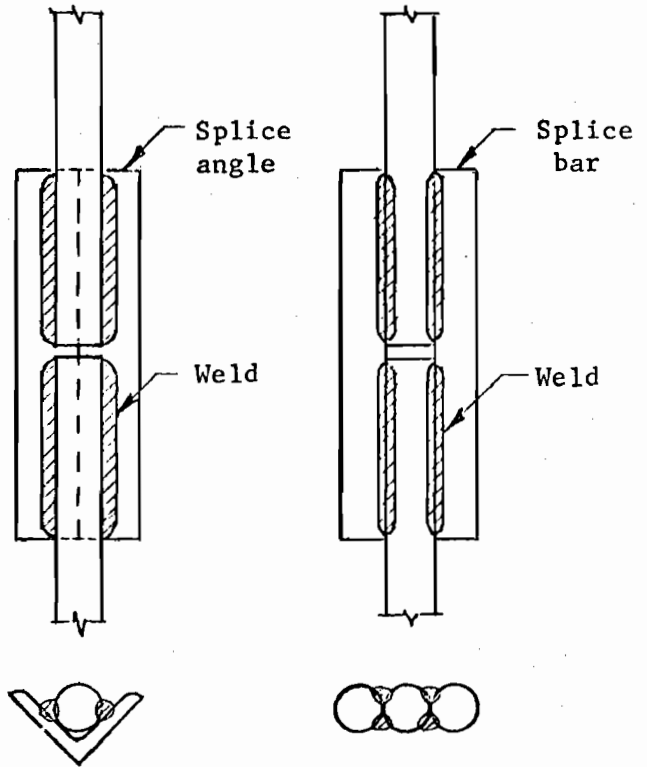

(b) DOUBLE LAP SPLICES

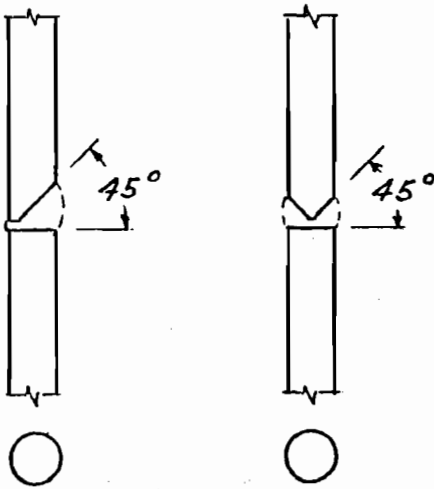

Single-Bevel Groove Weld

Double-Bevel Groove Weld

Vertical Bars

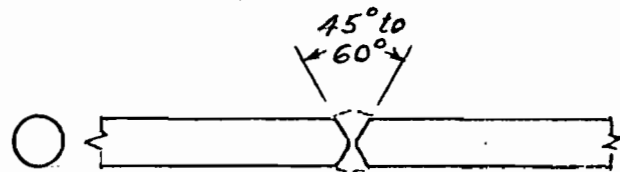

Double-Vee Groove Weld

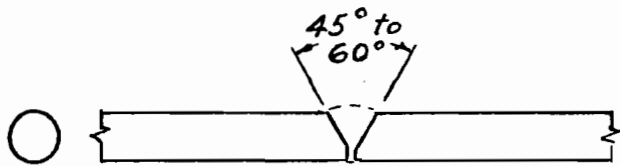

Single-Vee Groove Weld

Horizontal Bars

(c) BUTT SPLICES

Fig. 1 - Welded Splices for Reinforcing Steel

Welding Procedures

Welding procedures should be specified in the construction details. They will depend upon the kind of splice, the size of the bars, the composition of the steel, the position and accessibility of the welds, the atmospheric temperature, and other factors.

Procedures and workmanship should conform to Section 4 of AWS D 12.1, "Welding Reinforcing Steel, Metal Inserts and Connections in Reinforced Concrete Construction" and Section 4 of AWS D 2.0, "Specifications for Welded Highway and Railway Bridges."

If thermit welding is to be used, procedures should conform to recommendations of the manufacturer of the materials. The thermit powder must be of a composition that will produce weld metal of strength and ductility comparable with that of the bars being spliced, and the quantity used must be sufficient to fill the splice mold and fuse the ends of the bars.

Qualification of Welders

Since the quality of each weld depends upon the experience and skill of the welder, only welders who have been qualified by tests as prescribed in the "Standard Qualification Procedure" (AWS B 3.0) of the American Welding Society¹ should be permitted to weld reinforcing bars. The contractor should be required to certify that each welder is currently qualified according to the "Standard Qualification Procedure" and to furnish the dates and results of his qualification tests.

Inspection

The bars to be welded and the weld materials to be used should be inspected for conformance to the specifications. Splice assemblies should be inspected prior to welding, for proper alignment and spacing of the parts, proper groove or bevel angles, and freedom from loose scale, slag, rust, grease, moisture, and other contaminants.

The welding process should be observed periodically by an experienced inspector to insure that the specified procedures are being followed and are producing good welds. Deposition of the weld metal should be observed, using a welder's mask.

¹Applicable portions of the "Standard Qualification Procedure" are given in Appendix A of AWS D 2.0, "Specification for Welded Highway and Railway Bridges."

Each completed weld should be inspected visually for cracks in the weld or base metal, for inadequate size, undercutting, or other visible defects. All slag must be cleaned from the surface of the weld and surrounding metal before the weld can be inspected adequately. Any weld in which a crack is apparent must be completely removed and rewelded. Undercutting that reduces the strength of the bar adjacent to the weld must be repaired by cleaning and adding more weld metal.

References

1. AWS D 12.1, Recommended Practices for Welding Reinforcing Steel, Metal Inserts and Connections in Reinforced Concrete Construction.² \$1.50
2. AWS D 2.0, Specifications for Welded Highway and Railway Bridges.² \$8.00
3. AWS A 5.1, Specification for Mild Steel Covered Arc-Welding Electrodes.² \$3.00
4. AWS A 5.2, Specification for Iron and Steel Gas-Welding Rods.² \$2.00
5. ACI 318-63, Building Code Requirements for Reinforced Concrete, American Concrete Institute. June 1963. \$3.00
6. Placing Reinforcing Bars, Concrete Reinforcing Steel Institute, 228 North La Salle Street, Chicago, Illinois 60601, 1968. \$2.00
7. Omer W. Blodgett, Design of Welded Structures, The James F. Lincoln Arc Welding Foundation, P. O. Box 3035, Cleveland, Ohio 44117. June 1966. \$7.00

²American Welding Society, Inc., 345 East 47th Street, New York, N. Y. 10017