

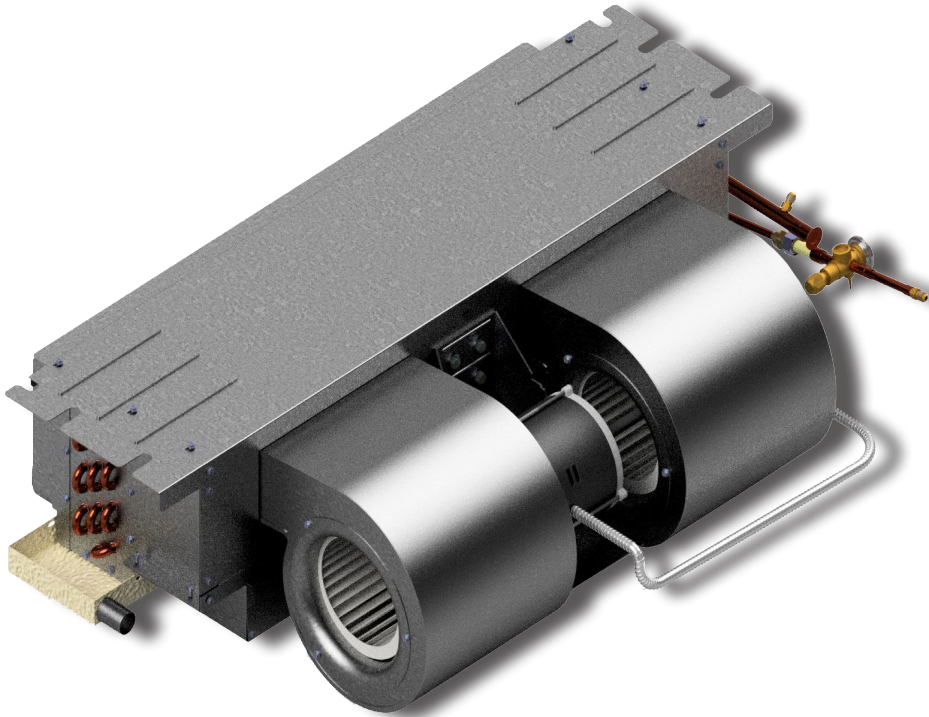

HX(X)

Ceiling Fan Coil

Horizontal Recessed
Cased and Uncased available
1-1/2 - 3 Ton Cooling
0 - 10 kW Electric Heat



PRODUCT DESCRIPTION

- Compatible with most split-system condensing units and heat pumps (*heat pumps with electric heat require field added kit*).
- All HX(X) fan coils include a 240/24V transformer and are completely prewired with 0 to 10 kW of electric heat.
- For HX(X) fan coils factory installed within an enclosure, add “-C” after the kW in the model number
- A optional solid or louvered panel can be used with the C model

STANDARD FEATURES

- Drain pan has 3/4” NPT primary and secondary (overflow) fittings
- 240V motor, 24V controls
- Factory installed electric heat (up to 10 kW) (except 0 kW models)
- Highly efficient copper tube/aluminum fin heating and cooling coils. Cooling coil has a piston-type metering device or factory or field installed R410A TXV (non-bleed type). Contact factory for correct match with outdoor unit.
- Insulated and coated galvanized steel drain pan is sloped for proper drainage.
- Cabinet air leakage is no more than 2% when tested in accordance with ASHRAE 193.
- High efficiency ECM motor for HXX model

OPTIONAL FEATURES

- Attractive off-white return air / access panel with captive screws (panels can be field painted)
- IAQ filter panels
- Fully insulated enclosure with matching ceiling panel (enclosure can be pre-installed). Also allows for ducted return air.
- Heat pump kit - for all HX models with electric heat (**#942-1**) (field installed)
- Factory or field installed R410 TXV (non-bleed type)
- Condensate overflow switch (**# SS3**) (Field installed)
- Enclosure (Cap” kit - for above the ceiling installation)
- Optional bolt on Merv-13 rated filter box for cased units.

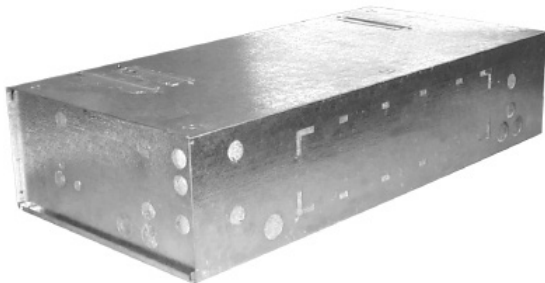

Optional Insulated Enclosure



Matching Access Panel for Enclosure
(non-louvered shown)

First Co.'s customer is ultimately responsible for confirming which fan coil models are compatible with selected outdoor unit(s) and which expansion valves (if any) are required. To determine certified indoor/outdoor matches, go to www.ahridirectory.org or www.firstco.com.

CEILING ACCESS PANELS

- For HX's installed without enclosure



965-1, 966-1,
967-1, 967-7



965, 966, 967, 967-6
(Louvers may differ from picture)
Louvered panels accept 20x20x1" filter
(field supplied)



965-M8
(accepts 1-20x30x1 filter)
966-M8, 967-M8
(accepts 2-20x20x1 filter)
967-6-M8
(accepts 2-20x25x1 filter)
(GlasFloss® Industries Series
HV filter or equivalent is
recommended)

IAQ PANELS

STANDARD PANELS

MODEL NUMBER	PANEL NO. (STD.)	PANEL NO. (IAQ)	DESCRIPTION	CEILING PANEL OPENING		PANEL FRAME DIMS. (OUTSIDE)	
				W	L	W	L
18, 19, 24HX	965	965-M8	LOUVERED	24-1/2	40	27-1/2	43
	965-1	NA	NON-LOUVERED	24-1/2	40	27-1/2	43
20, 25, 30HX	966	966-M8	LOUVERED	24-1/2	46	27-1/2	49
	966-1	NA	NON-LOUVERED	24-1/2	46	27-1/2	49
26, 31, 36HX	967	967-M8	LOUVERED	24-1/2	52-1/2	27-1/2	55-1/2
	967-1	NA	NON-LOUVERED	24-1/2	52-1/2	27-1/2	55-1/2
28, 32, 37HX	967-6	967-6-M8	LOUVERED	24-1/2	60	27-1/2	63
	967-7	NA	NON-LOUVERED	24-1/2	60	27-1/2	63



ENCLOSURES WITH CEILING PANELS

- Panels are sold separately for cased and uncased units.

MODEL NUMBER	ENCLOSURE NO.	ENCLOSURE DIMENSIONS			PANEL NO. (STD.)	PANEL NO. (IAQ)	DESCRIPTION (2)	CEILING PANEL OPENING		PANEL FRAME DIMS (OUTSIDE)	
		H	W	D				W	L	W	L
18, 19, 24HX	9EHX01	11	39-3/4	23-7/8	965	965-M8*	LOUVERED	24-1/2	40	27-1/2	43
					965-1	NA	NON-LOUVERED	24-1/2	40	27-1/2	43
20, 25, 30HX	9EHX02	11	45-3/4	23-7/8	966	966-M8*	LOUVERED	24-1/2	46	27-1/2	49
					966-1	NA	NON-LOUVERED	24-1/2	46	27-1/2	49
26, 31, 36HX	9EHX03	11	51-3/4	23-7/8	967	967-M8*	LOUVERED	24-1/2	52-1/2	27-1/2	55-1/2
					967-1	NA	NON-LOUVERED	24-1/2	52-1/2	27-1/2	55-1/2
28, 32, 37HX	9EHX04	11	58-3/4	23-7/8	967-6	967-6-M8*	LOUVERED	24-1/2	60	27-1/2	63
					967-7	NA	NON-LOUVERED	24-1/2	60	27-1/2	63

NOTES:

(1) Panels do not mount to cases.

(2) Panels are sold separately from cases or cased units

(*) Add -2 to end of panel number for panel that accepts 2" filter.

(See Panel Pictures Above)

ENCLOSURES WITH CEILING PANELS (CONT.)

- Panels are sold separately for cased and uncased units.

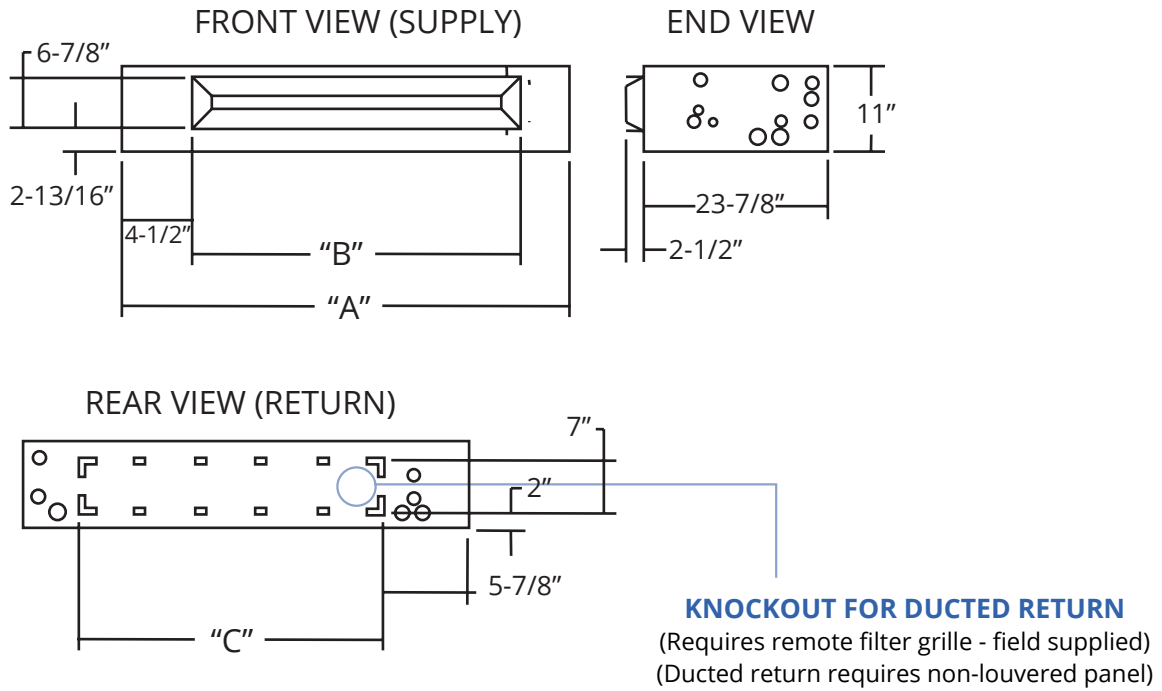

Picture shown is enclosure with installed HX(X) (Available from the factory as a complete unit)

HX ENCLOSURE DIMENSIONS				
FOR MODEL	ENCLOSURE NO.	A	B	C
18, 19, 24HX	9EHX01	39-3/4	30-5/8	28
20, 25, 30HX	9EHX02	45-3/4	36-5/8	34
26, 31, 36HX	9EHX03	51-3/4	42-5/8	40
28, 32, 37HX	9EHX04	58-3/4	50	46-3/4

HXX ENCLOSURE DIMENSIONS				
FOR MODEL	ENCLOSURE NO.	A	B	C
19, 24HXX	9EHX01	39-3/4	30-5/8	28
20, 25HXX	9EHX02	45-3/4	36-5/8	34
26, 31HXX	9EHX03	51-3/4	42-5/8	40
28, 32, 37HXX	9EHX04	58-3/4	50	46-3/4

MERV RATED FILTER BOX FOR ENCLOSURES

SINGLE FILTER FOR SIZE 18-30HX & 9EHX01, 9EHX02

PART NUMBER

1000-1

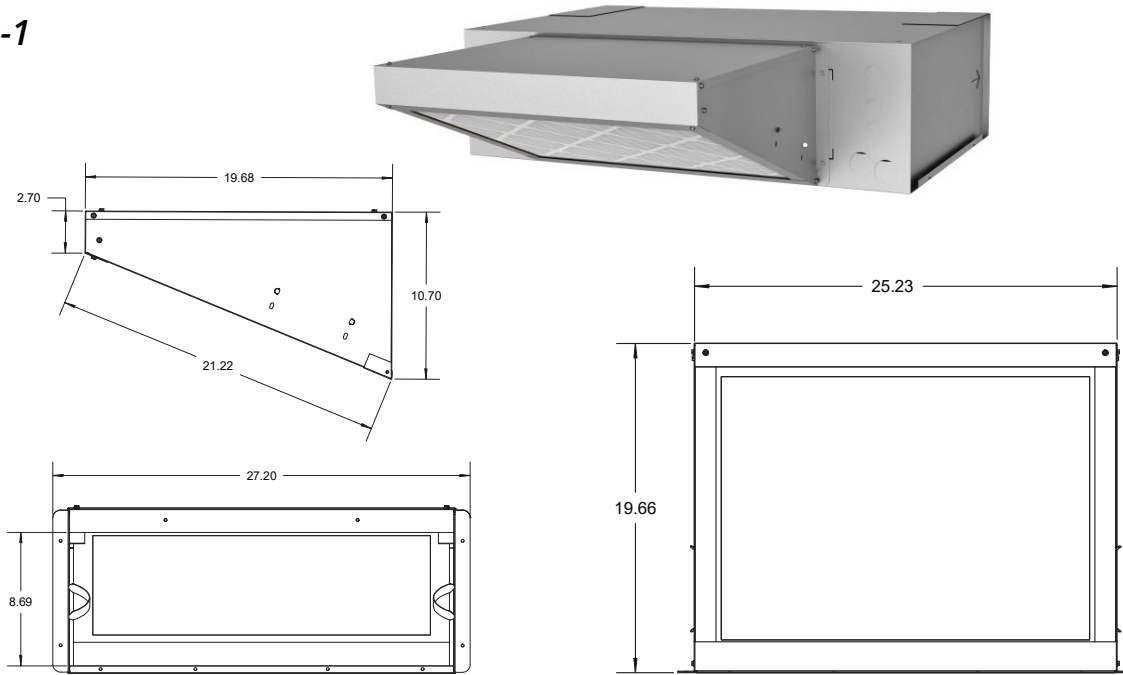

DOUBLE FILTER FOR SIZE 31-37HX & 9EHX03, 9EHX04

PART NUMBER

1000-2

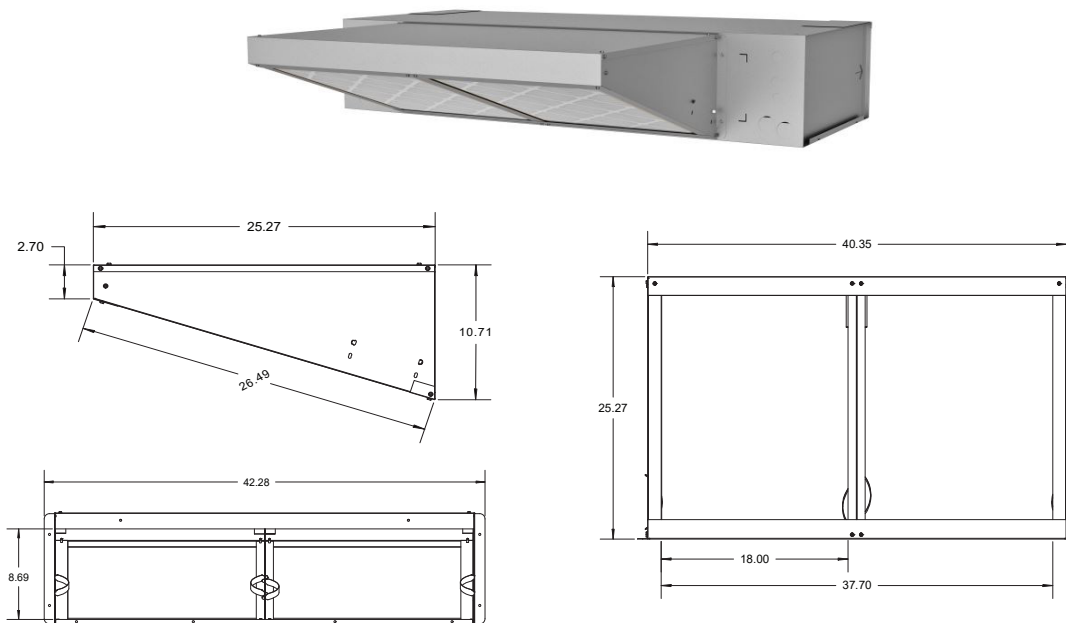

Note: Add 0.38 static with MERV13 Filter vs 0.30 static with MERV11 Filter (2" Filter)

MODEL NUMBERS

MODEL SIZE (BTU)	UNCASED (NO ENCLOSURE)		FACTORY INSTALLED ENCLOSURE	
	MODEL (PISTON)	MODEL (R410 TXV)	MODEL (PISTON)	MODEL (R410 TXV)
18,000	18HX(*)	18HX(*) R410 TXV	18HX(*)-C	18HX(*)-C R410 TXV
18,000	19HX(*)	19HX(*) R410 TXV	19HX(*)-C	19HX(*)-C R410 TXV
18,000	20HX(*)	20HX(*) R410 TXV	20HX(*)-C	20HX(*)-C R410 TXV
24,000	24HX(*)	24HX(*) R410 TXV	24HX(*)-C	24HX(*)-C R410 TXV
24,000	25HX(*)	25HX(*) R410 TXV	25HX(*)-C	25HX(*)-C R410 TXV
24,000	26HX(*)	26HX(*) R410 TXV	26HX(*)-C	26HX(*)-C R410 TXV
24,000	28HX(*)	28HX(*) R410 TXV	28HX(*)-C	28HX(*)-C R410 TXV
30,000	30HX(*)	30HX(*) R410 TXV	30HX(*)-C	30HX(*)-C R410 TXV
30,000	31HX(*)	31HX(*) R410 TXV	31HX(*)-C	31HX(*)-C R410 TXV
30,000	32HX(*)	32HX(*) R410 TXV	32HX(*)-C	32HX(*)-C R410 TXV
36,000	36HX(*)	36HX(*) R410A TXV	36HX(*)-C	36HX(*)-C R410 TXV
36,000	37HX(*)	37HX(*) R410 TXV	37HX(*)-C	37HX(*)-C R410 TXV

All TXV's are approved for cooling only or heat pump operation (non-bleed type)

(*) = kW HEAT

NOTE:
Expansion valve requirement depends on the selected outdoor unit. Go to www.firstco.com or contact the factory for assistance.

ENCLOSURE INSTALLATION SUPPORT FRAMING



ENCLOSURE CONNECTION LOCATIONS

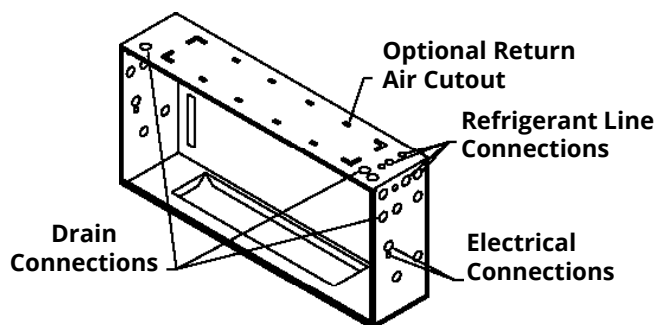

CAP KIT - FOR INSTALLATION ABOVE A SUSPENDED CEILING		
PART NO.	FITS ENCLOSURE NO.	FOR UNIT MODEL
9PHX01	9EHX01	18, 19, 24HX-C
9PHX02	9EHX02	20, 25, 30HX-C
9PHX03	9EHX03	26, 31, 36HX-C
9PHX04	9EHX04	28, 32, 37HX-C

NOTES:
(1) Cap kit is an insulated panel that covers the entire bottom opening of the enclosure (requires ducted return)
(2) Cap kit would be used in lieu of the ceiling panel and mounts to the case.

1-1/2 THROUGH 3 TON

ELECTRICAL DATA											
UNIT MODEL	NOM. CFM	NOM. COOL BTUH	HEAT Kw			TOTAL AMPS	MIN. CIR. AMPACITY		(2) MAX FUSE		
			208V	240V	BTUH		208V	240V	208V	240V	
18HX	-5 -6	600	18,000	2.3	5	17,000	22.8	25	30	25	30
				3.8	6	20,500	27.0	30	35	30	35
	-0.51						1.0	2	2	15	15
19HX & 20HX	-3 -5 -6 -8	600	18,000	2.3	3	10,200	13.5	15	18	15	20
				3.8	5	17,000	21.8	24	30	25	30
				4.5	6	20,500	26.0	29	35	30	35
				6.0	8	27,300	34.3	38	47	40	50
24, 25HX & 26, 28HX	-0.59 -3 -5 -6 -8 -10	800	24,000	---	---	---	2.0	3	3	15	15
				2.3	3	10,200	14.5	16	20	20	20
				3.8	5	17,000	22.8	25	30	25	30
				4.5	6	20,500	27.0	29	35	30	35
				6.0	8	27,300	35.3	39	47	40	50
				7.5	10	34,100	43.6	48	55	50	60
30, 31HX & 32HX	-0.63 -3 -5 -6 -8 -10	1000	30,000	---	---	---	2.0	3	3	15	15
				2.3	3	10,200	14.5	16	20	20	20
				3.8	5	17,000	22.8	25	30	25	30
				4.5	6	20,500	27.0	29	35	30	35
				6.0	8	27,300	35.3	39	47	40	50
				7.5	10	34,100	43.6	48	55	50	60
36HX & 37HX	-0.70 -3 -5 -6 -8 -10	1200	36,000	---	---	---	2.8	4	4	15	15
				2.3	3	10,200	15.3	18	20	20	20
				3.8	5	17,000	23.6	27	30	30	30
				4.5	6	20,500	27.8	31	35	35	35
				6.0	8	27,300	36.1	40	46	40	50
				7.5	10	34,100	44.5	49	56	50	60

EXPANSION VALVE KITS (Heat pump or cooling only)		
PART NO.	TYPE	FOR
9EVR410-1	R410A	18 - 37HX(X) (1-1/2 - 3 TON)

NOTES:

- Above expansion valve kits are approved for both cooling only (non heat pump) or heat pump applications.
- Valves are non-bleed type. Field added. Hard start kit may be required.
- Valves have screw-on connections.
- Field installed.

HEAT PUMP KIT (FIELD INSTALLED)	
PART NO.	DESCRIPTION
942-1	KIT FOR HX(X) MODELS WITH ELECTRIC HEAT

NOTE: Heat pump kit must be field installed for all HX(X) models with electric heat. 0 kW models do not require kit. **Contact the factory for compatibility match with condensing unit.**

- All BTUH heating ratings at 240V - derate heating capacities by 25% for 208V
- Maximum fuse or HACR-type circuit breaker.

BLOWER DATA								
UNIT MODEL	MOTOR HP (240V)	CFM vs. EXTERNAL STATIC PRESSURE						
		0.00	0.05	0.10	0.15	0.20	0.25	0.30
18HX	1/8	810	775	740	705	670	640	610
19HX	1/8	820	785	750	715	680	650	620
20HX	1/8	850	815	780	745	710	670	630
24, 28HX	1/4	910	875	840	805	770	730	690
25HX	1/4	930	895	860	825	790	750	710
26HX	1/4	960	925	890	850	810	770	730
30, 31HX	1/4	1110	1075	1040	990	940	900	860
32HX	1/4	1170	1140	1110	1075	1040	1000	960
36HX	1/3	1410	1370	1330	1290	1250	1210	1170
37HX	1/3	1460	1420	1380	1340	1300	1250	1200

PHYSICAL DIMENSIONS				
MODEL	A	B	C	D
18HX 19HX 24HX	37-1/4	34-11/16	30	6-1/2
20HX 25HX 30HX	43-1/4	40-11/16	36	6-1/2
26HX 31HX 36HX	49-1/4	46-11/16	42	6-1/2
28HX 32HX 37HX	56-1/4	53-11/16	49	6-1/2

- Add .05 static when enclosure is used.



Approved for installation with 0" clearance to combustible materials

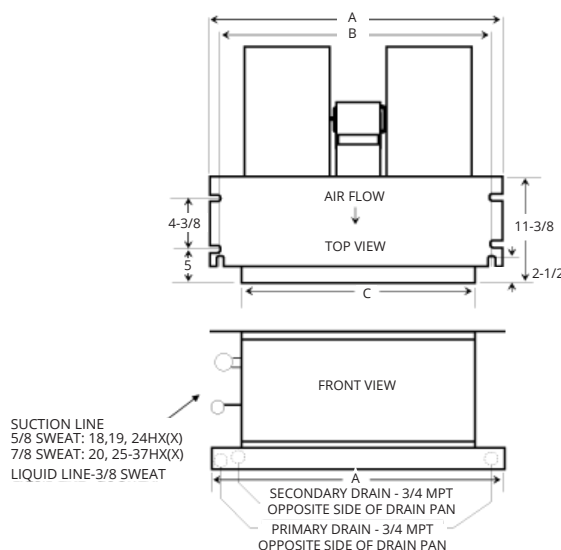
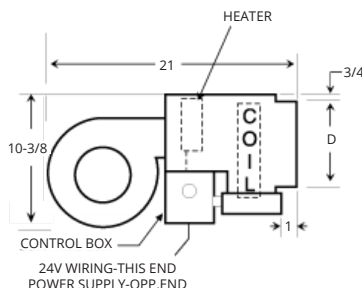

In keeping with its policy of continuous progress and product improvement, First Co. reserves the right to make changes without notice. Maintenance for all First Co. products is available at www.firstco.com.

1-1/2 THROUGH 3 TON

ELECTRICAL DATA											
UNIT MODEL	NOM. CFM	NOM. COOL BTUH	HEAT KW			TOTAL AMPS		MIN. CIR. AMPACITY		MAX FUSE	
			208V	240V	BTUH	208V	240V	208V	240V	208V	240V
			---	---	---	4.3	4.3	6	6	15	15
19HXX 20HXX	600	18,000	---	---	---	4.3	4.3	6	6	15	15
			2.3	3	10,200	15.2	16.8	19	21	20	25
			3.8	5	17,000	22.4	25.2	28	32	30	35
			4.5	6	20,500	26.0	29.3	33	37	35	40
			6.0	8	27,300	33.2	37.7	42	47	50	50
7.5	10	34,100	40.4	46.0	51	58	60	60			
24HXX 25HXX 26HXX 28HXX	800	24,000	---	---	---	4.3	4.3	6	6	15	15
			2.3	3	10,200	15.2	16.8	19	21	20	25
			3.8	5	17,000	22.4	25.2	28	32	30	35
			4.5	6	20,500	26.0	29.3	33	37	35	40
			6.0	8	27,300	33.2	37.7	42	47	50	50
7.5	10	34,100	40.4	46.0	51	58	60	60			
31HXX 32HXX	1000	30,000	---	---	---	4.3	4.3	6	6	15	15
			2.3	3	10,200	15.2	16.8	19	21	20	25
			3.8	5	17,000	22.4	25.2	28	32	30	35
			4.5	6	20,500	26.0	29.3	33	37	35	40
			6.0	8	27,300	33.2	37.7	42	47	50	50
7.5	10	34,100	40.4	46.0	51	58	60	60			
37HXX	1200	36,000	---	---	---	4.3	4.3	6	6	15	15
			2.3	3	10,200	15.2	16.8	19	21	20	25
			3.8	5	17,000	22.4	25.2	28	32	30	35
			4.5	6	20,500	26.0	29.3	33	37	35	40
			6.0	8	27,300	33.2	37.7	42	47	50	50
7.5	10	34,100	40.4	46.0	51	58	60	60			

- (1) All BTUH heating ratings at 240V - derate heating capacities by 25% for 208V
- (2) Maximum fuse or HACR-type circuit breaker.

EXPANSION VALVE KITS (Heat pump or cooling only)		
PART NO.	TYPE	FOR
9EVR410-1	R410A	18 - 37HX(X) (1-1/2 - 3 TON)

NOTES:

- (1) Above expansion valve kits are approved for both cooling only (non heat pump) or heat pump applications.
- (2) Valves are non-bleed type. Field added. Hard start kit may be required.
- (3) Valves have screw-on connections.
- (4) Field installed.

HEAT PUMP KIT (FIELD INSTALLED)	
PART NO.	DESCRIPTION
942-1	KIT FOR HX(X) MODELS WITH ELECTRIC HEAT

NOTE: Heat pump kit must be field installed for all HX(X) models with electric heat. 0 kW models do not require kit. **Contact the factory for compatibility match with condensing unit.**

BLOWER DATA														
UNIT MODEL	MOTOR HP (240V)	SPEED TAP	MOTOR BHP	NOM. AMPS	CFM vs. EXTERNAL STATIC PRESSURE									
					0.00	0.05	0.10	0.15	0.20	0.25	0.30	0.35	0.40	.50
					19HXX	1/2	OPTIONAL HIGH STD. HIGH STD. LOW	.16 .10 .08	1.2 .08 .07	800	765	730	695	660
660	630	600	575	550						525	500	-	-	-
590	555	520	495	470						445	420	-	-	-
20HXX	1/2	OPTIONAL HIGH STD. HIGH STD. LOW	.16 .10 .08	1.2 .08 .07	800	765	730	695	660	620	580	535	490	395
					650	625	600	575	550	525	500	-	-	-
					590	560	530	505	480	455	430	-	-	-
24HXX	1/2	OPTIONAL HIGH STD. HIGH STD. LOW	.31 .23 .17	1.2 1.5 1.0	1000	985	965	950	935	915	900	885	865	830
					860	840	820	800	780	765	745	-	-	-
					715	685	660	640	615	595	580	-	-	-
25HXX	1/2	OPTIONAL HIGH STD. HIGH STD. LOW	.30 .20 .16	2.1 1.5 1.0	970	950	930	910	890	870	850	825	800	755
					810	790	770	745	720	705	690	-	-	-
					720	690	660	645	630	615	600	-	-	-
26HXX	1/2	OPTIONAL HIGH STD. HIGH STD. LOW	.30 .20 .16	2.1 1.5 1.0	1010	980	950	925	900	880	860	840	820	795
					840	810	780	760	740	720	700	-	-	-
					750	715	680	655	630	615	600	-	-	-
28HXX	1/2	OPTIONAL HIGH STD. HIGH STD. LOW	.30 .20 .16	2.1 1.5 1.0	970	950	930	910	890	870	850	825	800	755
					810	790	770	745	720	705	690	-	-	-
					720	690	660	645	630	615	600	-	-	-
31HXX	1/2	OPTIONAL HIGH STD. HIGH STD. LOW	.43 .32 .24	3.3 2.2 1.5	1230	1195	1160	1140	1120	1090	1060	995	930	825
					1060	1015	970	945	920	875	830	-	-	-
					920	885	850	810	770	735	700	-	-	-
32HXX	1/2	OPTIONAL HIGH STD. HIGH STD. LOW	.43 .32 .24	3.3 2.2 1.5	1280	1245	1210	1180	1150	1115	1080	1025	970	870
					1090	1050	1010	985	960	930	900	-	-	-
					950	920	890	855	820	790	760	-	-	-
37HXX	1/2	OPTIONAL HIGH STD. HIGH STD. LOW	.51 .43 .32	4.0 3.3 2.2	1430	1400	1370	1355	1320	1295	1270	1220	1170	1085
					1260	1225	1190	1160	1130	1115	1100	-	-	-
					1110	1080	1050	1025	1000	970	940	-	-	-

- (1) Add .05 static when enclosure is used.
- ** Does not include electric heat
- ** (---) Does not meet the minimum 350 CFM requirement

PHYSICAL DIMENSIONS				
MODEL	A	B	C	D
19HXX 24HXX	37-1/4	34-11/16	30	6-1/2
20HXX 25HXX	43-1/4	40-11/16	36	6-1/2
26HXX 31HXX	49-1/4	46-11/16	42	6-1/2
28HXX 32HXX 37HXX	56-1/4	53-11/16	49	6-1/2

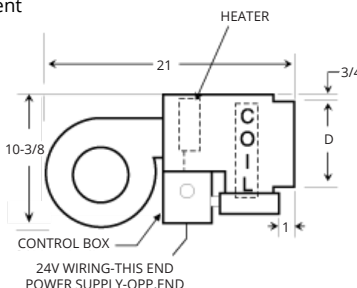
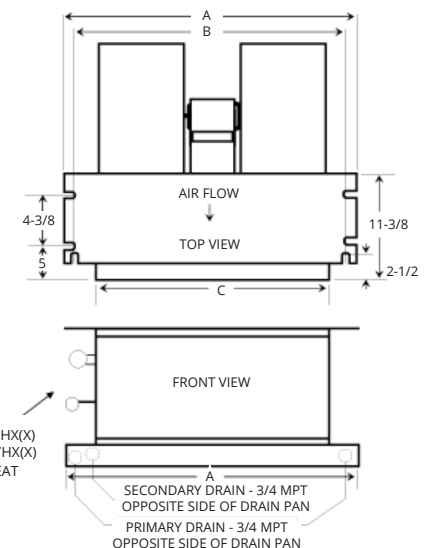

Approved for installation with 0" clearance to combustible materials

In keeping with its policy of continuous progress and product improvement, First Co. reserves the right to make changes without notice. Maintenance for all First Co. products is available at www.firstco.com.



FIRST CO.

P.O. BOX 270969 - DALLAS, TEXAS 75227

PH. (214) 388-5751 | FAX (214) 388-2255

WWW.FIRSTCO.COM

MAY 2024