

**LOAD CASE 1
BASIC SCENARIOS**

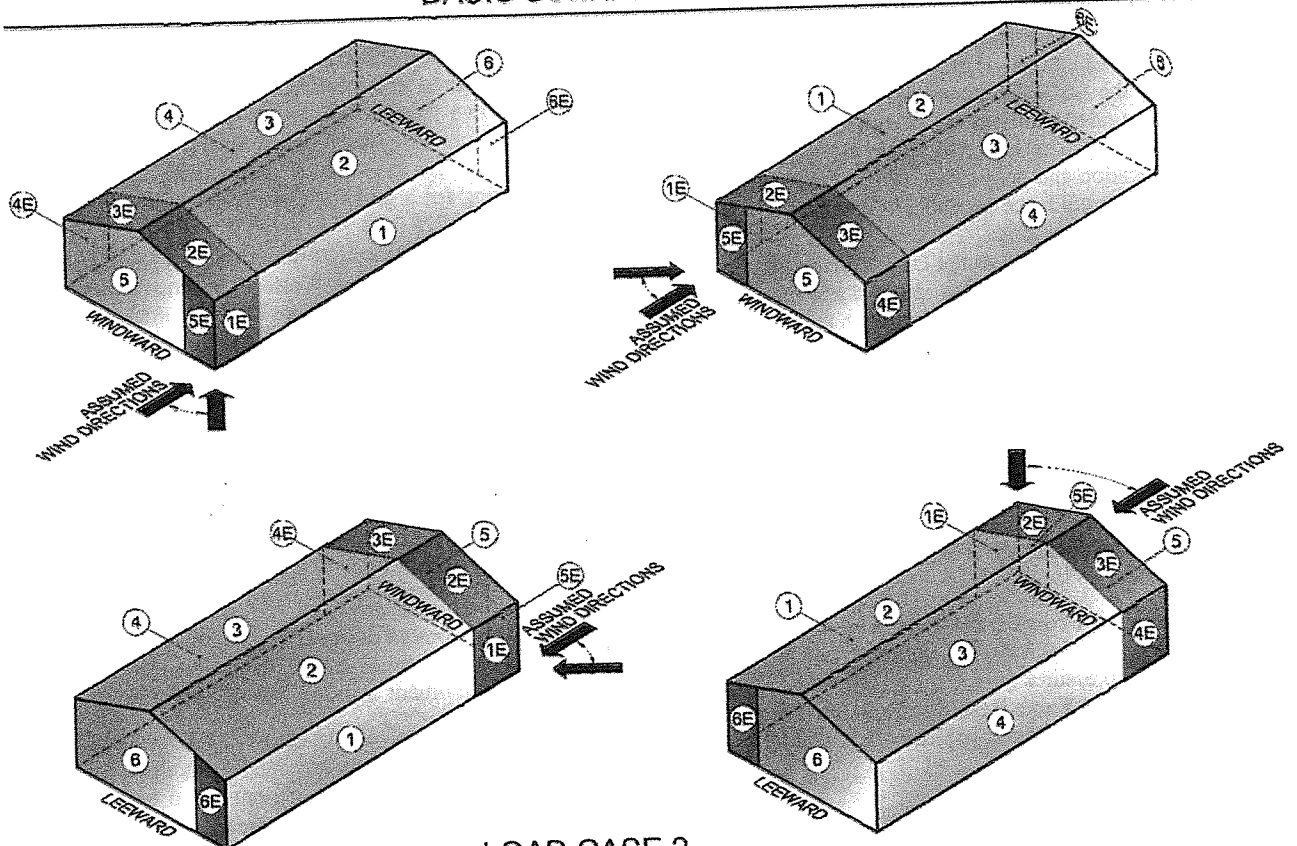

**LOAD CASE 2
BASIC SCENARIOS**

Figure C28.3-1. Illustration of load application in Figure 28.3-1.

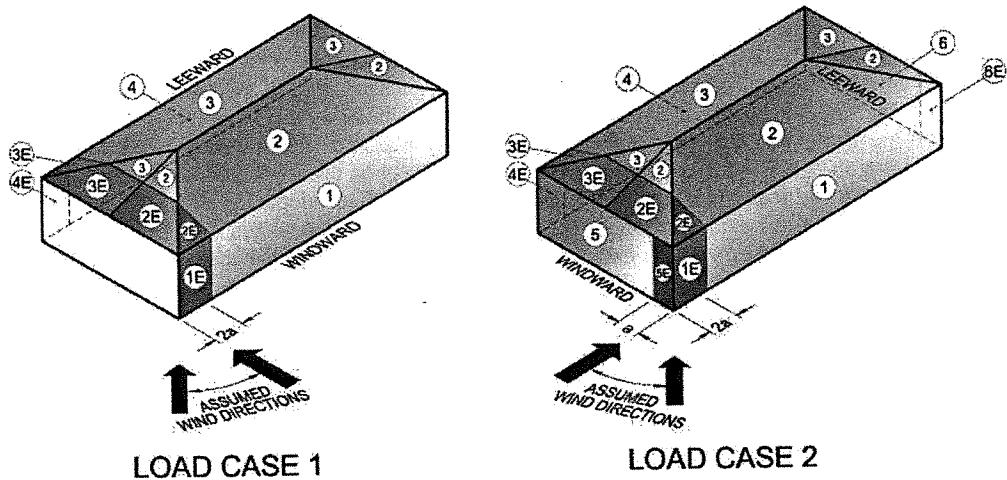

Notes:

1. Adapt the loadings shown in Figure 28.3-1 for hip-roofed buildings as shown. For a given hip roof pitch, use the roof coefficients from the Case 1 table for both Load Case 1 and Load Case 2.
2. The total horizontal shear shall not be less than that determined by neglecting the wind forces on roof surfaces.

Figure C28.3-3. Loads application for hip-roofed low-rise buildings.