

1

Product information

Chapter contents

Product features	22
Features of the HP color LaserJet 9500 series printer	23
Features of the HP Color LaserJet 9500mfp	24
Product specifications for the printer	25
Identification	25
Specifications	25
Environmental specifications	26
Product overviews	28
External assembly locations	28
Accessories	29
Space requirements	32
Printer with packaging	32
Physical dimensions of the printer models and the MFP	33
Printer setup	36
Media specifications	37
Guidelines for selecting media	37
Supported media and capacity for input and output	38
Recommended media	39
Special media specifications	41
Storing print media	45
Testing media specifications	45
Media assessment tools and suppliers	50

Product features

This manual contains service information for the HP color LaserJet 9500 Series printer and the print engine portion of the HP color LaserJet 9500mfp. For MFP models, you also need the *HP Scanner/ADF Service Manual for the HP LaserJet 9000mfp/9000Lmfp/9040mfp/9050mfp/9500mfp* (PN C8449-90955) and the *2,000-sheet Side Input Tray Service Manual* (PN Q1891-90901) for complete MFP service information.

Throughout this document, the term “printer” is used to refer to both the HP LaserJet 9500 Series printer models *and* the HP LaserJet 9500mfp. Make sure to read the headings and text carefully to understand the context of the term.



HP Color LaserJet 9500n printer (C8546A)

The HP color LaserJet 9500n printer comes standard with a 128-MB RAM DIMM, wide-format printing capability, tray 1 (a 100-sheet multipurpose tray), tray 2 and tray 3 (500-sheet trays), and an HP Jetdirect print server.



HP Color LaserJet 9500hdn printer (C8547A)

The HP color LaserJet 9500hdn printer comes standard with a 256-MB RAM DIMM, a 20-GB EIO hard disk, wide-format printing capability, tray 1 (a 100-sheet multipurpose tray), tray 2 and tray 3 (500-sheet trays), tray 4 (a 2,000-sheet feeder), an HP Jetdirect print server, and a duplexer (for printing on both sides of media).



HP Color LaserJet 9500mfp (C8549A)

The HP color LaserJet 9500hdn printer comes standard with a 512-MB RAM DIMM, a 20-GB EIO hard disk, wide-format printing capability, tray 1 (a 100-sheet multipurpose tray), tray 2 and tray 3 (500-sheet trays), tray 4 (a side 2,000-sheet feeder), one of five finishing devices, an HP Jetdirect print server, and a duplexer (for printing on both sides of media).

Note

This manual is used to service the entire HP color LaserJet 9500 Series printer and to service the HP color LaserJet 9500mfp *print engine* only. To service the ADF/scanner portion of the HP color LaserJet 9500mfp, see your *HP Scanner/ADF Service Manual for the HP LaserJet 9000mfp/9000Lmfp/9040mfp/9050mfp/9500mfp* (PN C8549-90955). To service the 2,000-sheet side-input tray, see your *2,000-sheet Side-input Tray Service Manual* (PN Q1891-90901).

A complete service manual bundle is available by ordering the *Service Bundle for HP Color LaserJet 9500/9500mfp* (PN C8549-99001). The service bundle includes the manuals listed above, this print engine manual, and the *Paper Handling Accessories Service Addendum* (PN C85693-90002).

Features of the HP color LaserJet 9500 series printer

Table 1. Features of the HP color LaserJet 9500 series printer

Speed	<ul style="list-style-type: none">● Up to 24 pages per minute (ppm) for letter- or A4-size media● Half-speed for glossy or heavy media● First page out in less than 17 seconds● Duplexes up to 24 sides per minute for letter- or A4-size media
Resolution	<ul style="list-style-type: none">● 600-by-600 dots per inch (dpi) with Resolution Enhancement technology (REt)● HP ImageRet 4800● Up to 256 levels of gray
Consumables	<ul style="list-style-type: none">● Four no-pull-tab print cartridges● Four image drums
Language and fonts	<ul style="list-style-type: none">● PostScript® (PS) Level 3 emulation with 35 built-in PS language fonts● HP printer command language (PCL) 6 driver● HP PCL 5c driver for compatibility with previous products● Printer job language (PJM)● Printer management language● 80 scalable TrueType typefaces● Direct .pdf printing
Enhanced memory and memory expansion	<ul style="list-style-type: none">● Memory Enhancement technology (MEt) automatically compresses data to use RAM more efficiently● 128 MB of RAM, expandable to 384 MB by using industry-standard 168-pin DIMM
Functions	<ul style="list-style-type: none">● Tray 1 supports up to 100 sheets or 10 envelopes for automatic and manual feeding of paper envelopes, labels, transparencies, custom-sized media (98 by 191 mm [3.8 by 7.5 in] to 312 by 470 mm [12.3 by 18.5 in]), and heavy paper● Tray 2 and tray 3 support up to 500 sheets of media● Tray 4 supports letter, legal, B4, A4, 11-by-17 inch, A3, executive, B5, and custom (182 by 210 mm [7.2 by 8.3 in] to 297 by 431.8 mm [11.7 by 17 in]) print media● Two-sided printing (duplex printing) available● Wide-format printing● Glossy printing and document finishing options (hdn model only)
Expandability	<ul style="list-style-type: none">● HP color LaserJet 9500 duplexer (standard in the 9500hdn model)● 3,000-sheet stapler/stacker (for the 9500hdn model only)● 3,000-sheet stacker (for the 9500hdn model only)● Multifunction finisher (for the 9500hdn model only)● Enhanced input/output (EIO) cards● DIMM slots for adding memory and fonts● Accepts a 10-GB hard disk for RIP Once capability, job retention features, and font storage (the hard disk is standard on the 9500hdn model)
Wireless printing	<ul style="list-style-type: none">● Supports wireless printing with the installation of a Fast InfraRed Connect pod (IrDA compliant)● Wireless EIO card
Interface connection	<ul style="list-style-type: none">● Bidirectional ECP type-C parallel port (IEEE-1284 compliant)● Three EIO slots for installation of a hard-disk accessory or print server● Foreign interface connector● HP Jet-Link connector
Networking	<ul style="list-style-type: none">● HP 615N Jetdirect print server
Maximum monthly duty cycle	<ul style="list-style-type: none">● 200,000 images per month

Features of the HP Color LaserJet 9500mfp

The HP color LaserJet 9500 Series printer and the HP color LaserJet 9500mfp share most of the same features. The following list specifies which features are different from those on the printer or unique to the MFP:

- The MFP includes no top output tray and therefore has no paper path components to top output tray
- The MFP control panel has different features. See the *HP Scanner/ADF Service Manual for the HP LaserJet 9000mfp/9000Lmfp/9040mfp/9050mfp/9500mfp* for information about the control panel configuration.
- The 2,000-sheet feeder tray 4 is a side delivery feeder.
- A finishing device is required on the MFP.
- The MFP formatter differs from the printer formatter.

Product specifications for the printer

Identification

Note

See the *HP Scanner/ADF Service Manual for the HP LaserJet 9000mfp/9000Lmfp/9040mfp/9050mfp/9500mfp* (PN C8549-90955) for information that is specific to the MFP version.

For the HP color LaserJet 9500 Series printer, a user-accessible label is located inside the right door of the print engine. The model number is alphanumeric, such as C8547A.

The serial number contains information about the country/region of origin and the revision level, production code, and production number of the printer. An example of a serial number is USBB123456.

The identification label also contains electrical information and regulatory information (see figure 1).

Note

The electrical information and regulatory information vary by country/region.

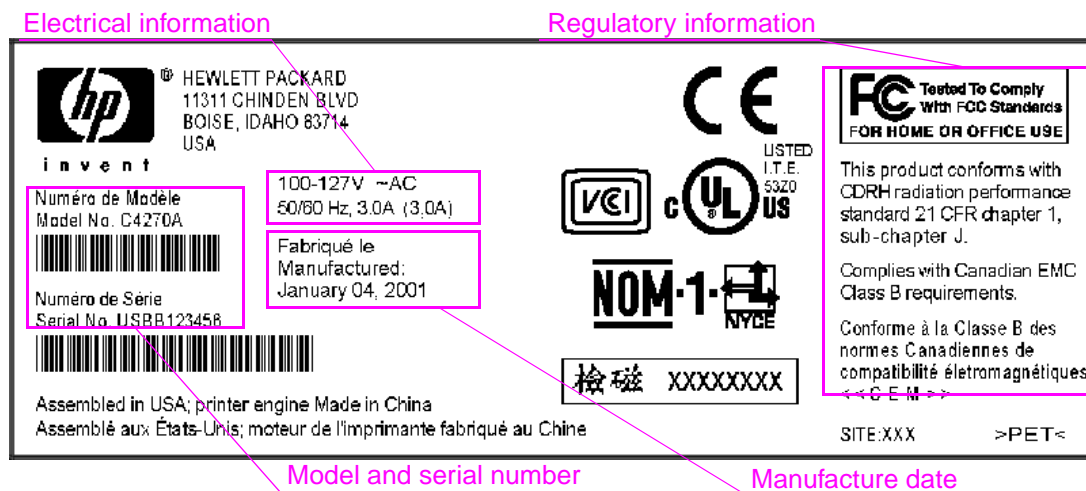

Figure 1.

Sample identification label

Specifications

Note

See the *HP Scanner/ADF Service Manual for the HP LaserJet 9000mfp/9000Lmfp/9040mfp/9050mfp/9500mfp* (PN C8549-90955) for information that is specific to the MFP version.

Table 2. Out-of-box specifications

Specification	HP color LaserJet 9500n	HP color LaserJet 9500hdn
Height	887 mm (34.9 inches)	1,212 mm (47.8 inches)
Width	682 mm (26.9 inches)	682 mm (26.9 inches)
Depth	767 mm (30.2 inches)	767 mm (30.2 inches)
Weight without print cartridges and image drums	100 kg (221 lb)	130 kg (287 lb)
Weight with print cartridges and image drums in packaging	174 kg (383 lb)	198 kg (436 lb)

Table 3. Packaged specifications

Specification	HP color LaserJet 9500n	HP color LaserJet 9500hdn
Height	1,313 mm (51.7 inches)	1,488 mm (58.6 inches)
Width	1,200 mm (47.2 inches)	1,200 mm (47.2 inches)
Depth	1,022 mm (40.2 inches)	1,022 mm (40.2 inches)

Table 4. Power requirements and circuit capacity

	110-volt models	220-volt models
Power requirements	100 to 127 V (+/- 10%) 50 to 60 Hz (+/- 2 Hz)	220 to 240 V (+/- 10%) 50 to 60 Hz (+/- 2 Hz)
Minimum recommended circuit capacity	15.0 Amps (dedicated circuit)	10.0 Amps (dedicated circuit)

WARNING!

Power requirements are based on the country/region where the printer is sold. Do not convert operating voltages. This can damage the printer and void the product warranty.

Table 5. Power consumption

Printer state	HP color LaserJet 9500n	HP color LaserJet 9500hdn
Printing (24 ppm)	722 W	741 W
Standby (Ready)	171 W	173 W
Low PowerSave (ENERGY STAR®)	69 W	69 W
High PowerSave (Blue Angel)	32 W	32 W
Off	<2 W	<2 W

Environmental specifications

The environmental specifications must be maintained to ensure the proper operation of the printer. Consider the following points before installing the printer:

- Install the printer in a well-ventilated, dust-free area.
- Install the printer on a level, flat surface that can support its size and weight. Do not install on carpet or on other soft surfaces. Make sure that all four printer feet are level.
- Install the printer where temperature and humidity are stable, with no abrupt changes (away from water sources, humidifiers, air conditioners, refrigerators, or other major appliances).
- Install the printer away from direct sunlight, areas that experience vibration, open flames, ammonia fumes, ultrasonic heaters, and devices that emit a magnetic field. If the printer is placed near a window, make sure that the window has a curtain or blind to block direct sunlight.
- Maintain enough space around the printer for proper access and ventilation.

Table 6. Environmental specifications

	Allowable condition	Recommended condition
Operating temperature	10° to 30° Celsius (C) (50° to 86° Fahrenheit [F])	20° to 26°C (68° to 79°F)
Relative humidity	10 to 80 percent	20 to 50 percent
Storage temperature	15° to 30°C (59° to 86°F)	20° to 26°C (68° to 79°F)
Storage humidity	5 percent to 95 percent	5 percent to 95 percent

Table 7. Noise level specifications

Acoustics	Printing (24 ppm)	PowerSave
Sound power level	$L_{WA_d} = 67 \text{ dB(A)}$	essentially inaudible
Sound pressure level, L_{pAm} (Bystander position)	$L_{pAm} = 50 \text{ dB(A)}$	essentially inaudible

Note

Testing per International Standards Organization (ISO) 9296.

Product overviews

External assembly locations

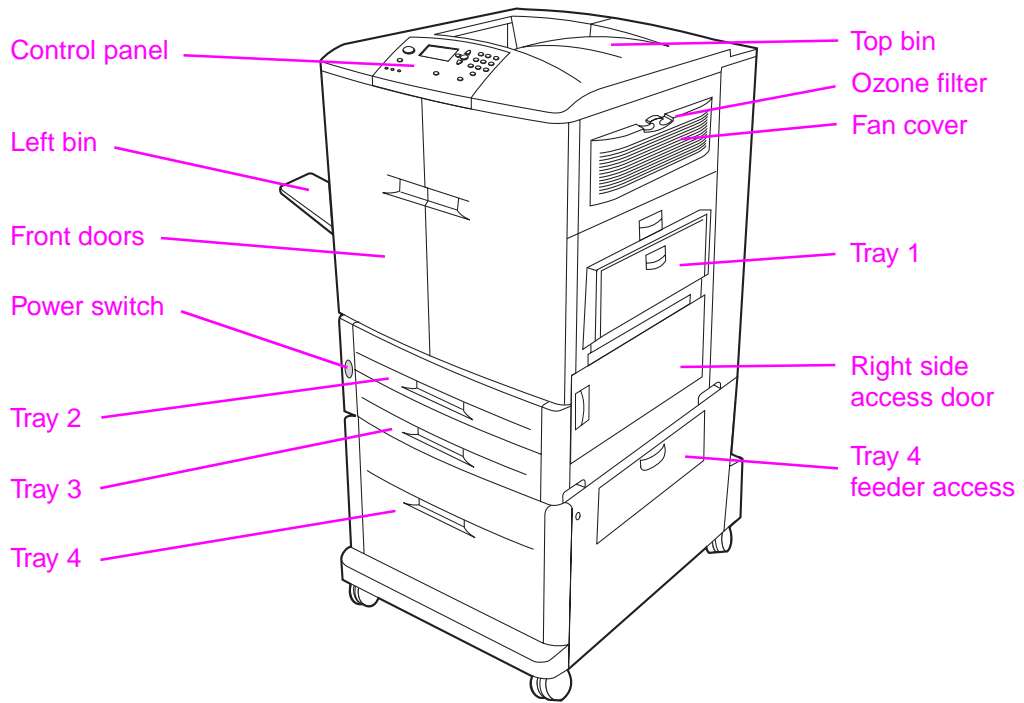

Figure 2. Front and right side assembly locations (HP LJ 9500 Series printer)

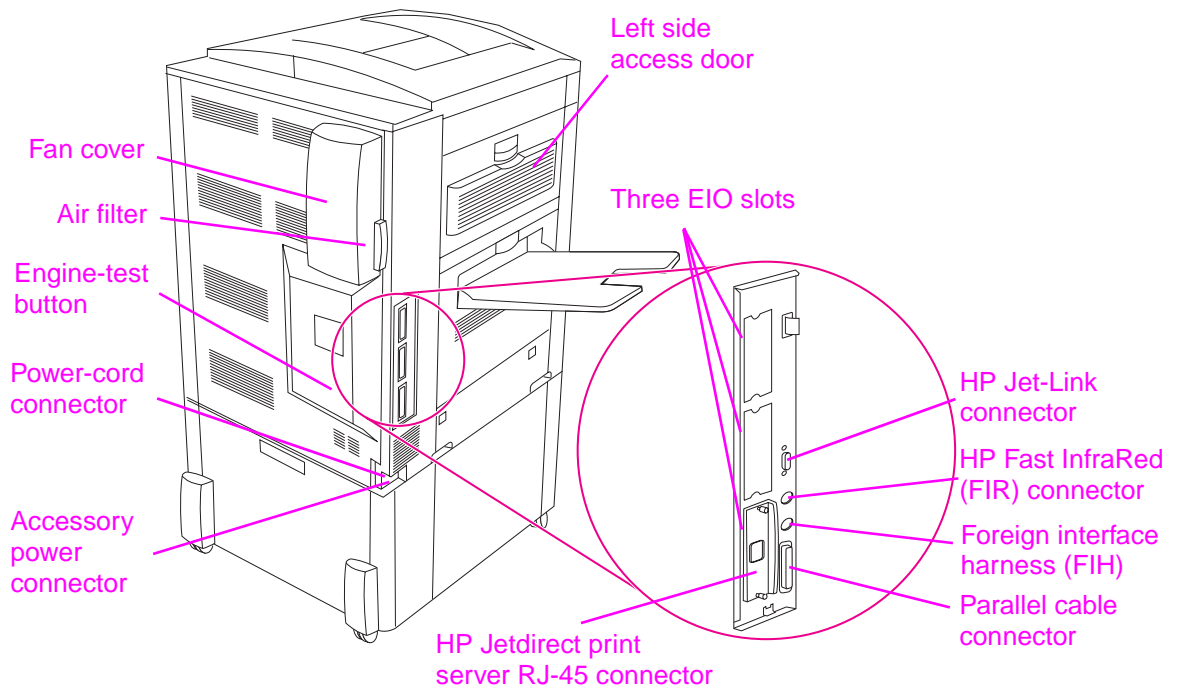
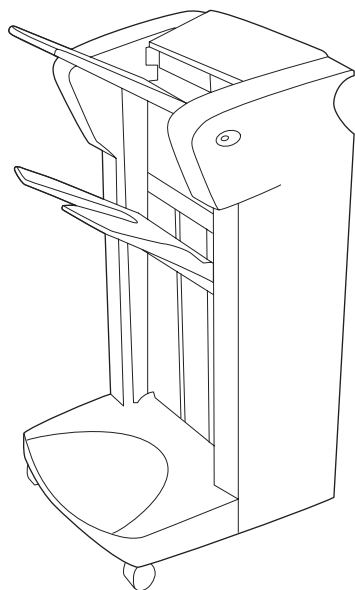
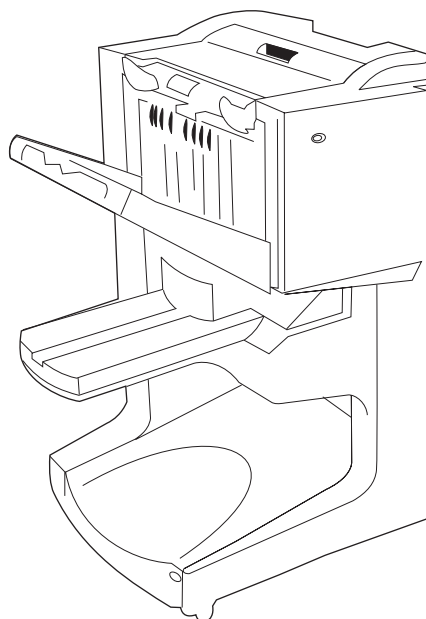

Figure 3. Back and left side assembly locations (HP LJ 9500 Series printer)

Accessories



3,000-sheet stapler/stacker (C8085A)
or 3,000-sheet stacker (C8084A)



Multifunction finisher (C8088A)

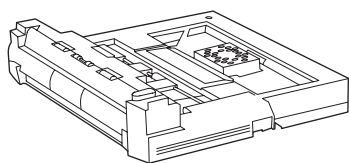

Duplexer (C9674A)



HP Fast InfraRed
receiver (FIR) (C4103A)

Figure 4. Accessories for the HP LJ 9500 Series printer

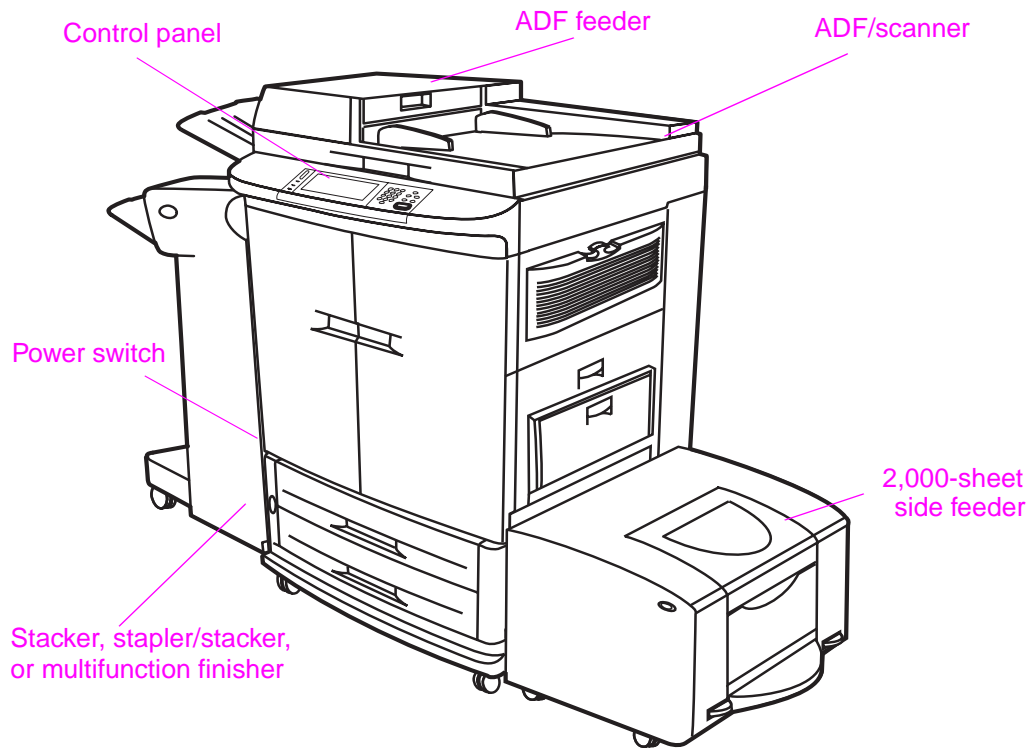

Figure 5. Front and right side view (HP LJ 9500mfp)

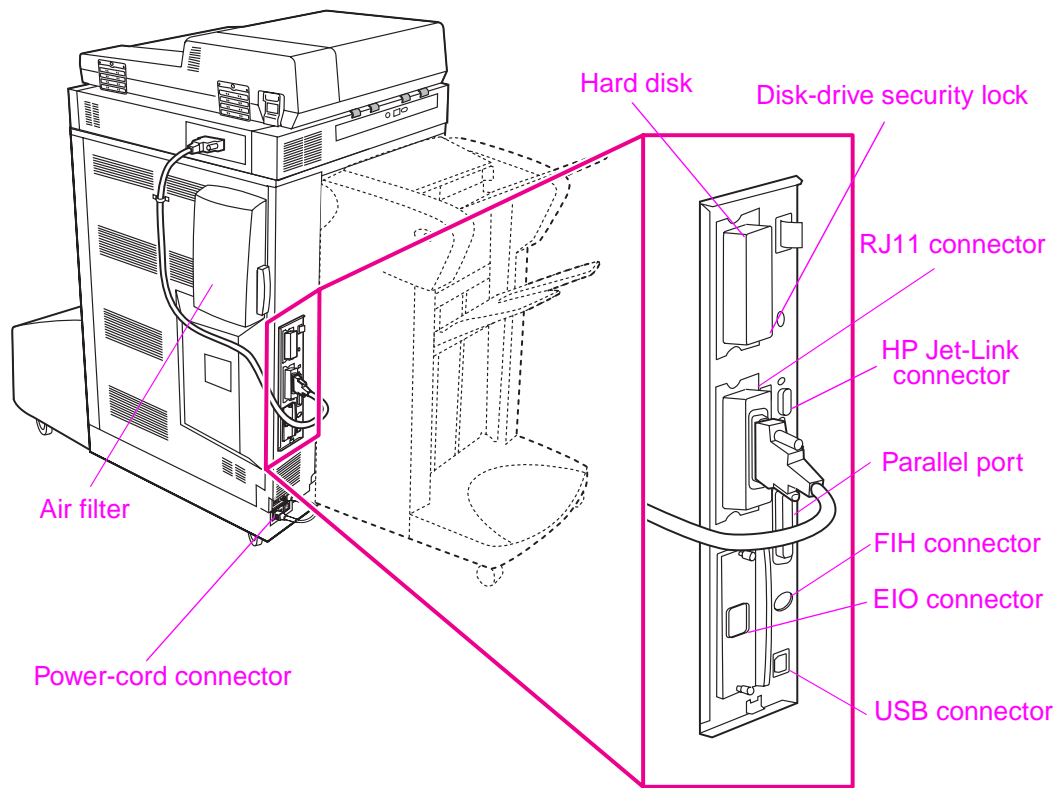

Figure 6. Back and left side view (HP LJ 9500mfp)

Space requirements

Note See the *HP Scanner/ADF Service Manual for the HP LaserJet 9000mfp/9000Lmfp/9040mfp/9050mfp/9500mfp* (PN C8549-90955) for information that is specific to the MFP version.

Printer with packaging

The shipping box that contains the HP color LaserJet 9500 series printer is 1,200 mm (47.2 inches) wide and 1,022 mm (40.2 inches) deep. The shipping box that contains the HP color LaserJet 9500n is 1,313 mm (51.7 inches) high, and the shipping box that contains the HP color LaserJet 9500hdn is 1,488 mm (58.6 inches) high. The in-box weight of the HP color LaserJet 9500n is 174 kg (383 lb), and the in-box weight of the HP color LaserJet 9500hdn is 198 kg (436 lb). The customer must locate a door or receiving area that is large enough to accept delivery of the shipping box.

Note Before removing the printer from the box, make sure that adequate space is available to unpack the printer and to roll the product off of the shipping pallet. At least 10 feet of clearance around the box is required to remove all of the shipping materials.

Physical dimensions of the printer models and the MFP

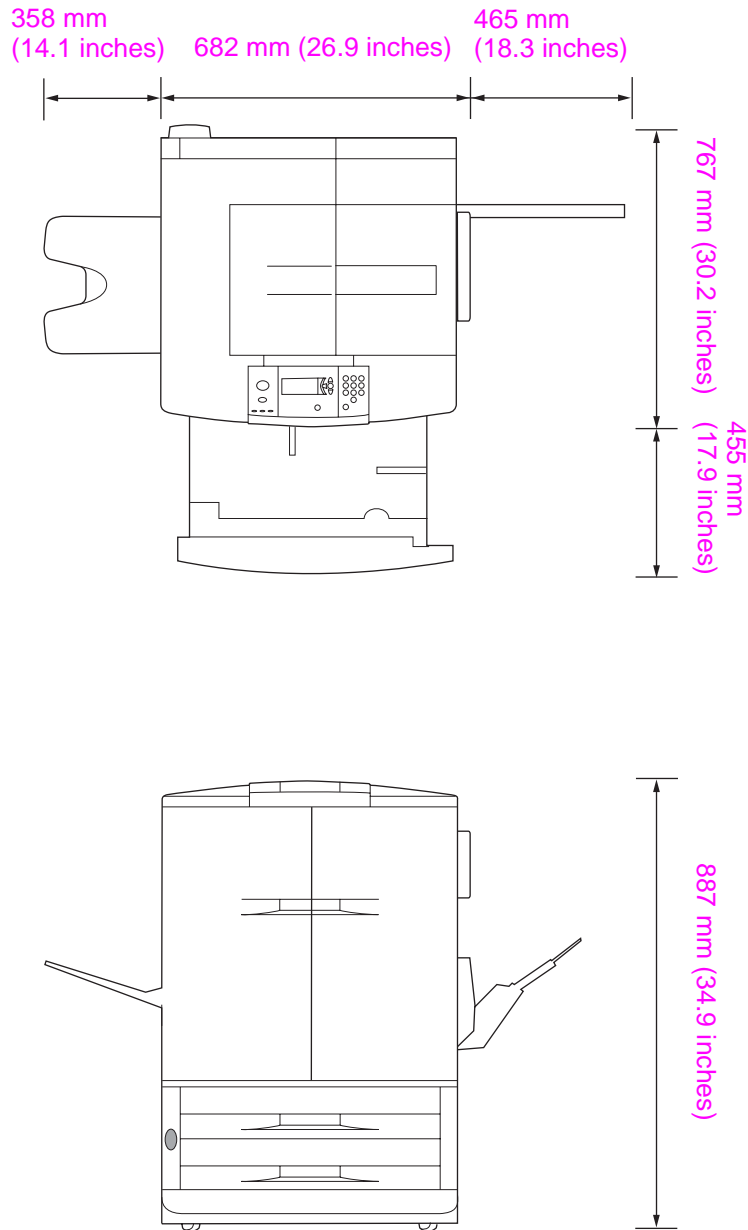

Figure 7. HP color LaserJet 9500n printer dimensions (top and front views)

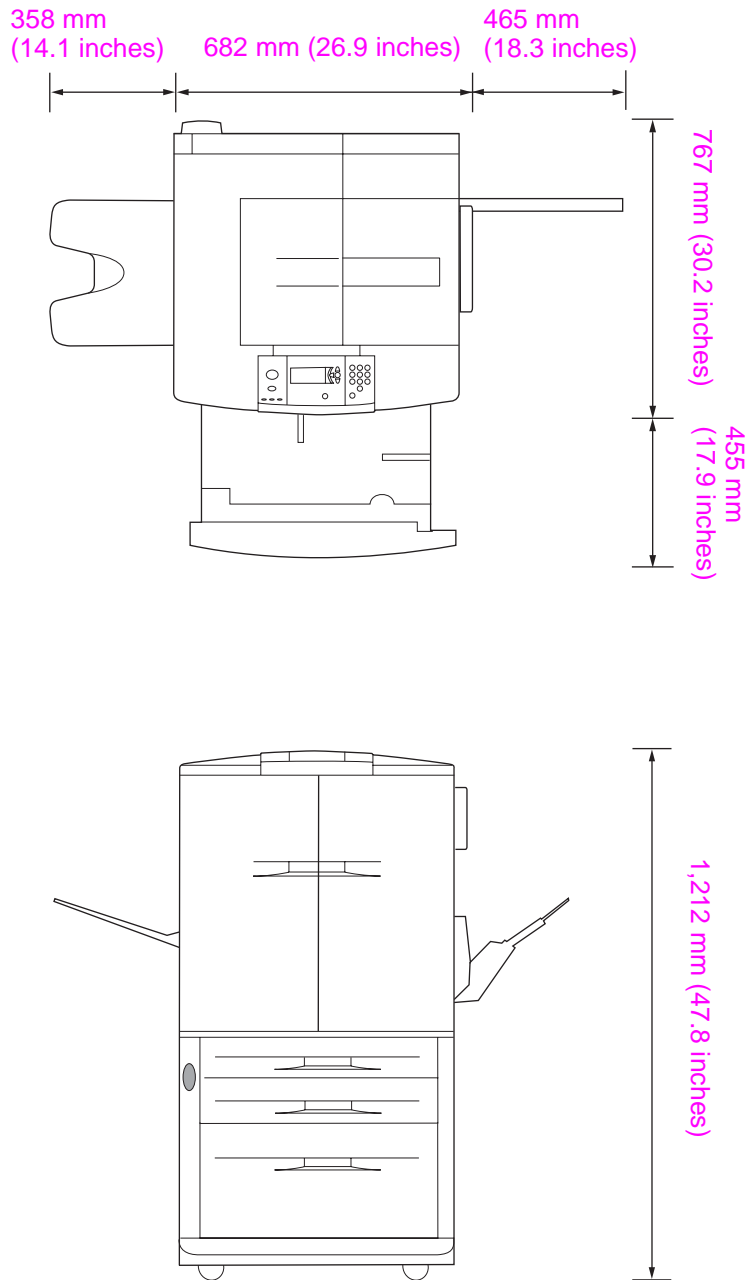

Figure 8. HP color LaserJet 9500hdn printer dimensions (top and front views)

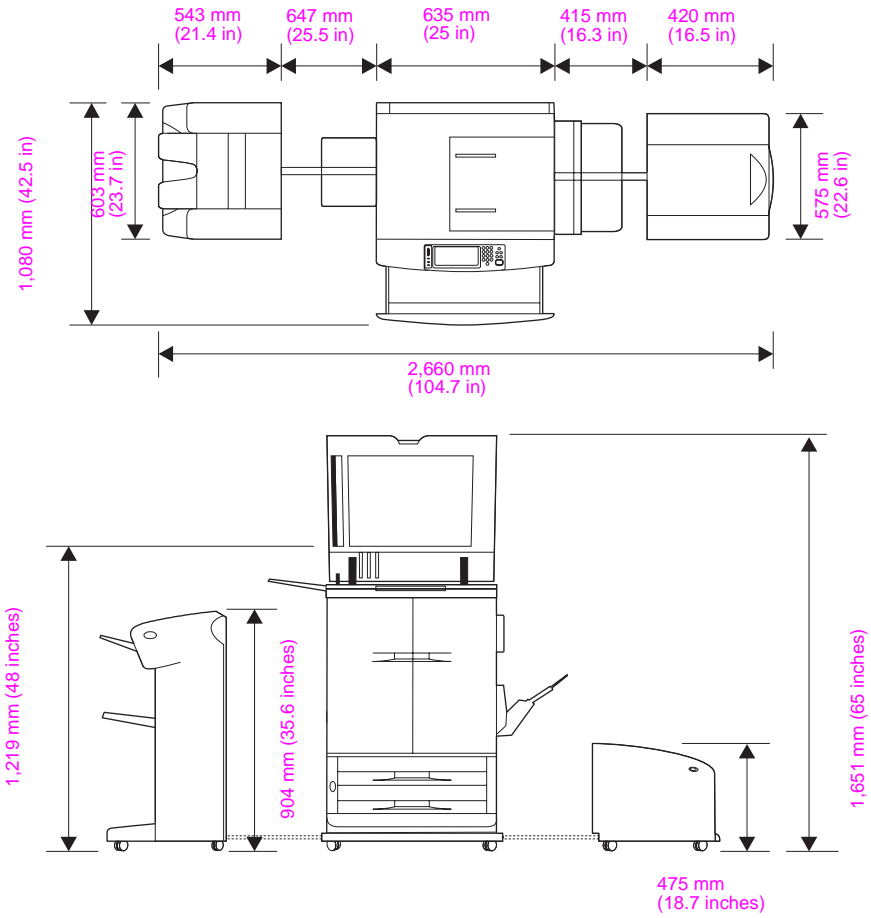

Figure 9. HP color LaserJet 9500mfp dimensions

Printer setup

Note

See the *HP Scanner/ADF Service Manual for the HP LaserJet 9000mfp/9000Lmfp/9040mfp/9050mfp/9500mfp* (PN C8549-90955) for information about the MFP.

The initial printer setup includes the following steps:

- Remove the printer from the box.
- Set up and install the printer. See the *HP color LaserJet 9500 User Reference Guide* at <http://www.hp.com/support/lj9500>.
- Set up and install the finishing device (for the 9500hdn only). See the install guide that came with the finishing device.

The shipping box contains the following items:

- HP color LaserJet 9500 series printer
- One power cord
- Control panel overlay
- Consumables box
 - Four print cartridges
 - Four image drums
 - One image cleaning blade
 - One toner collection bottle
- Printer software on CD-ROM (includes the *HP color LaserJet 9500 User Reference Guide*)
- *Start* guide

Note

The finishing device is delivered in a separate box (optional for the 9500hdn model only).

The HP color LaserJet 9500hdn is delivered with the duplexer, hard disk, network card, and tray 4 installed.

Media specifications

Before purchasing large quantities of print media, make sure that it meets the requirements specified in this service manual and in the *HP color LaserJet 9500 User Reference Guide*. Always test the print media before buying large quantities.

Hewlett-Packard neither warrants nor recommends the use of a particular brand of paper or print media other than HP media. Media properties are subject to manufacturing changes, and HP has no control over such changes. Although testing the media helps to characterize the performance and the manufacturer's process quality, the customer assumes all responsibility for the quality and performance of media.

CAUTION

Using print media that does not meet HP specifications might cause problems for the product, requiring repair. Such repair is not covered by the Hewlett-Packard warranty or service agreements.

The HP color LaserJet 9500 series printers accept a variety of media, such as cut-sheet paper (including up to 100 percent recycled fiber-content paper), envelopes, labels, transparencies, and custom-size paper. Properties such as weight, composition, grain, and moisture content are important factors affecting printer performance and output quality. Media that does not meet the guidelines outlined in this manual and in the print media guide can cause the following problems:

- poor print quality
- increased jams
- premature wear on the printer, requiring repair

Guidelines for selecting media

This product accepts a variety of media, such as cut-sheet paper (including recycled paper), envelopes, labels, transparencies, and custom-size paper. Properties such as weight, grain, and moisture content are important factors that affect product performance and print quality.

Selecting media by type and size at the control panel and in the printer driver results in significantly better print quality for heavy paper and glossy paper. Using the wrong setting can result in unsatisfactory print quality. Always print by type for special print media such as labels or transparencies. Always print by size for envelopes.

The product can use a variety of paper and other print media in accordance with the guidelines in this manual. Paper that does not meet these guidelines can cause the following problems:

- poor print quality
- media jams and multiple-sheet feeds
- premature wear on the printer, requiring repair

Note

Some print media might meet all of the guidelines in this manual and still not produce satisfactory results. This might be the result of improper handling, unacceptable temperature and humidity levels, or other variables over which HP has no control.

If you are unsure what type of paper you are loading (such as bond or recycled), check the label on the package of paper.

- See “Basis weight field test” on page 46 for information about measuring basis weight.
- See “Caliper field test” on page 48 for information about measuring caliper.
- See “Paper finish field test” on page 48 for information about smoothness.

Hint

Do not purchase more media than can be easily used in a short time (about 3 months). Media that is stored for long periods experiences heat and moisture extremes that can be damaging. Planning is important to prevent damage to a large supply of media.

Supported media and capacity for input and output

Note

The leading edge is listed first in the dimension measurements.

Table 8. Supported standard media sizes

Printing task	Tray 1	Tray 2 and tray 3	Tray 4
Simplex, and manual and auto duplex	<ul style="list-style-type: none"> letter, legal, executive, ISO A3, ISO A4, ISO A5, 11 by 17, JIS B5, JIS B4, JPostD, 8K, 16K 	<ul style="list-style-type: none"> letter, legal, executive, ISO A3, ISO A4, ISO A5, JIS B4, JIS B5, 11 by 17 	<ul style="list-style-type: none"> letter, legal, executive, ISO A3, ISO A4, 11 by 17, JIS B4, JIS B5

Table 9. Maximum custom sizes

Printing task	Tray 1	Tray 2 and tray 3	Tray 4
Simplex, and manual and auto duplex	<ul style="list-style-type: none"> 306 by 470 mm (12.05 by 18.5 inches) 	<ul style="list-style-type: none"> 297 by 432 mm (11.7 by 17 inches) 	<ul style="list-style-type: none"> 297 by 432 mm (11.7 by 17 inches)

Table 10. Minimum custom sizes

Printing task	Tray 1	Tray 2 and tray 3	Tray 4
Simplex and manual duplex	<ul style="list-style-type: none"> 98 by 170 mm (3.9 by 6.7 inches) 	<ul style="list-style-type: none"> 148 by 210 mm (5.8 by 8.3 inches) 	<ul style="list-style-type: none"> 182 by 210 mm (7.2 by 8.3 inches)
Auto duplex	<ul style="list-style-type: none"> 148 by 210 mm (5.8 by 8.3 inches) 	<ul style="list-style-type: none"> 148 by 210 mm (5.8 by 8.3 inches) 	<ul style="list-style-type: none"> 182 by 210 mm (7.2 by 8.3 inches)

Table 11. Supported media weights

Printing task	Tray 1	Tray 2 and tray 3	Tray 4
Simplex and manual duplex	<ul style="list-style-type: none"> 64 to 220 g/m² (17- to 58-lb bond) 	<ul style="list-style-type: none"> 64 to 200 g/m² (17- to 53-lb bond) 	<ul style="list-style-type: none"> 64 to 200 g/m² (17- to 53-lb bond)
Auto duplex	<ul style="list-style-type: none"> 64 to 200 g/m² (17- to 53-lb bond) 	<ul style="list-style-type: none"> 64 to 200 g/m² (17- to 53-lb bond) 	<ul style="list-style-type: none"> 64 to 200 g/m² (17- to 53-lb bond)

Table 12. Input tray capacities

Type of media	Tray 1	Tray 2 and tray 3	Tray 4
Cut sheets	<ul style="list-style-type: none"> up to 100 sheets (10 mm total height, 5 mm total height for media that is 200 g/m² [53-lb bond] or heavier) 	Up to 500 sheets	Up to 2,000 sheets
Envelopes	<ul style="list-style-type: none"> up to 10 envelopes (10 mm total height) 	Not supported	Not supported

Table 13. Output bin capacities

Bin	75 g/m ² (20-lb bond)	Transparencies
Top bin (face down)	<ul style="list-style-type: none"> up to 500 sheets 	Up to 50 sheets
Left bin (face up)	<ul style="list-style-type: none"> up to 100 sheets 	Up to 10 sheets

CAUTION

Do not use paper that is heavier than 200 g/m² (53-lb bond) for duplex printing. Damage to the product and jams might result.

Recommended media

The media types that are listed in the following table meet these criteria:

- They have been tested in this product.
- They have proven to be of good quality.
- They work well with the product's settings.

Ordering recommended media

The product numbers for media are listed in parentheses after the media sizes. Use these product numbers when ordering media.

All of the HP-brand media is available at www.hpshopping.com or from your local office supplies retailer.

The product supports the StoraEnso paper that is listed in the table. It is available through your local office products supplier.

Note

Set the type at the control panel when you load the trays, and in the printer driver when you print your print job.

Table 14. Recommended media

Recommended media	Type	Characteristics
HP High Gloss Laser Paper letter (Q2419A) 11 by 17 (tabloid) (Q2420A) A4 (Q2421A) A3 (Q2422A)	HP HEAVY GLOSSY	120 g/m ² (32-lb bond), 200 sheets, high-gloss finish coating on both sides, 95 bright Use for: brochures, catalogs, business plans, photographs, and images
HP Premium Cover Paper letter (Q2413A) A4 (Q2414A)	CARDSTOCK >164 g/m ²	200 g/m ² (75-lb cover), 100 sheets, super-smooth matte finish on both sides, 96 bright Use for: postcards and document covers
HP Color Laser Paper letter (HPL245R) 11 by 17 (tabloid) (HPL2417)	PLAIN	90 g/m ² (24-lb bond), 500 sheets, smooth matte finish on both sides, 96 bright Use for: newsletters and color documents
HP Color Laser Paper 105 g/m ² (28-lb bond) letter (HPL285R) 11 by 17 (tabloid) (HPL2817)	PLAIN	105 g/m ² (28-lb bond), 500 sheets, smooth matte finish on both sides, 96 bright Use for: newsletters and color documents
HP Soft Gloss Laser Paper letter (C4179A) A4 (C4179B)	HP HEAVY GLOSSY	120 g/m ² (32-lb bond), 200 sheets, satin finish coating on both sides, 96 bright Use for: flyers, handouts, sales briefs, proposals, and color images
Note HP Soft Gloss Laser Paper is designed specifically for use with the HP color LaserJet 9500 series printers.		

Table 14. Recommended media (continued)

Recommended media	Type	Characteristics
HP Soft Gloss LaserPaper 105 g/m ² (28-lb bond) letter (Q2415A) 11 by 17 (tabloid) (Q2416A) A4 (Q2417A) A3 (Q2418A)	GLOSSY 75-105 g/m ²	105 g/m ² (28-lb bond), 500 sheets, satin finish coating on both sides, 96 bright Use for: flyers, handouts, sales briefs, proposals, and color images
HP Premium Choice LaserJet Paper letter (HPU1132) 11 by 17 (tabloid) (HPU1732) A4 (CHP410) A4 (Asia) (Q2397A) A3 (Asia) (Q2396A)	HEAVY 106-163 g/m ²	120 g/m ² (32-lb bond), 500 sheets (250 sheets for 11 by 17), matte finish on both sides, 98 bright Use for: proposals and charts
HP Premium Choice LaserJet Paper 160 g/m ² (42-lb bond) A4 (Europe) (CHP413) A3 (Europe) (CHP421)	HEAVY 106-163 g/m ²	160 g/m ² (42-lb bond), 250 sheets, matte finish on both sides 98 bright Use for: proposals and charts
HP LaserJet Paper letter (HPJ1124) 3-hole prepunched (HPJ113H) legal (HPJ1424) 11 by 17 (tabloid) (HPJ1724) A4 (Europe) (CHP310)	PLAIN	90 g/m ² (24-lb bond), 500 sheets, matte finish on both sides, 96 bright Use for: reports, user manuals, letterhead, and correspondence
HP Office Recycled Paper letter (HPE1120) 3-hole prepunched (HPE113H) legal (HPE1420)	PLAIN	75 g/m ² (20-lb bond), 500 sheets, matte finish on both sides, contains 30 percent post-consumer content (satisfies U.S. Executive Order 13101), 87 bright Use for: training manuals and general office printing
HP Tough Paper letter (Q1298A) A4 (Q1298B)	TOUGH PAPER	5 mil thick (approximately 44-lb bond equivalent), 50 sheets, satin finish coating on both sides, waterproof, tearproof Use for: signs, maps, restaurant menus, waterproof documents, and tearproof documents
HP Color LaserJet Transparencies letter (C2934A) A4 (C2936A)	TRANSPARENCY	5 il thick, 50 sheets, premium coated both sides Use for: transparencies
StoraEnso Futura Laser Cover 11 by 17 (01109)	NON HP HEAVY GLOSSY	163 g/m ² (60-lb cover), 250 sheets, coated, premium white Use for: document cover

Table 15. Media weight, finish, and type

Weight	Finish	Type
Less than 75 g/m ² (20-lb bond)	any	LIGHT<75 g/m
75 g/m ² (20-lb bond) to 105 g/m ² (28-lb bond)	matte	PLAIN
75 g/m ² (20-lb bond) to 105 g/m ² (28-lb bond)	glossy	GLOSSY 75-105 g/m
106 g/m ² (29-lb bond) to 163 g/m ² (43-lb bond)	matte	HEAVY 106-163 g/m
106 g/m ² (29-lb bond) to 163 g/m ² (43-lb bond)	glossy	HP HEAVY GLOSSY (if using HP-brand media) NON HP HEAVY GLOSSY (if using non-HP-brand media)
164 g/m ² (44-lb bond) and heavier	any	CARDSTOCK>164 g/m

Special media specifications

Envelope specifications

Successful printing on envelopes depends upon the quality of the envelopes. Envelope fold lines can vary considerably, not only between manufacturers, but also within a box from the same manufacturer. When selecting envelopes, consider the following components:

- **Construction:** Prior to printing, envelopes should lie flat with less than 6 mm (0.25 inch) curl, and have well-constructed seams.
- **Condition:** Envelopes should not be wrinkled, nicked, or otherwise damaged.
- **Temperature:** Envelopes should be compatible with the heat and pressure produced by the printer.

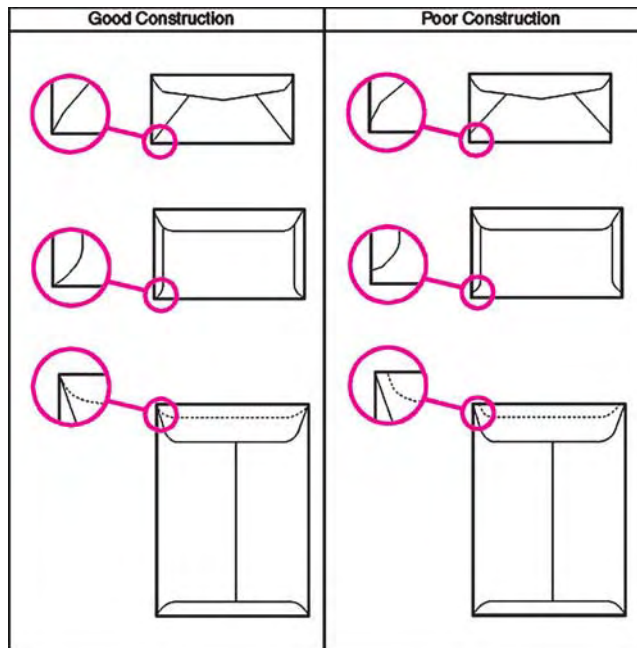

Figure 10. Sample seams

Note Print on envelopes from tray 1 only. Send envelopes straight through the printer, entering at tray 1 and exiting from the face-up bin.

For the best print quality, position margins no closer than 15 mm (0.6 inch) from the edges of the envelope. Avoid printing over the area where the envelope seams meet.

Envelopes with adhesive strips or multiple flaps

Envelopes with a peel-off adhesive strip, or with more than one flap that folds over to seal, must use adhesives that are compatible with the heat and pressure of the printer. The extra flaps might cause wrinkling, creasing, or jams.

Label specifications

CAUTION To avoid damaging the printer, use only labels that are recommended for laser printers. Never print on the same sheet of labels more than once and never print on a partial sheet of labels.

When selecting labels, consider the quality of each component:

- **Adhesives:** The adhesive material should be stable at 200° C (392° F), which is the printer fusing temperature.
- **Arrangement:** Do not use labels that have exposed backing between them. Labels can peel off sheets with spaces between the labels, causing jams.
- **Curl:** Prior to printing, labels must lie flat with no more than 13 mm (0.5 inch) of curl in any direction.
- **Condition:** Do not use labels that have wrinkles, bubbles, or other indications of separation.

Note Use only tray 1 to print on labels. Send labels straight through the printer, entering at tray 1 and exiting from the face-up bin.

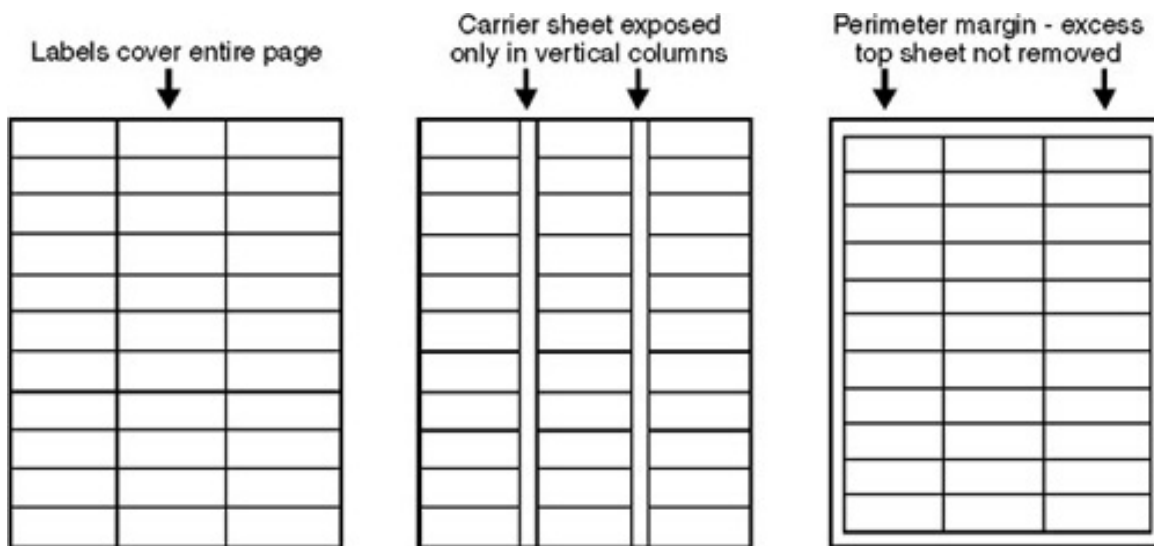

Figure 11. Adhesive labels

Card stock construction

When selecting card stock, consider the quality of each component:

- **Smoothness:** 135- to 220-g/m² (36- to 58-lb bond) card stock should have a smoothness rating of 100 to 180 Sheffield.
- **Curl:** Card stock should lie flat with less than 5 mm (0.2 inch) of curl.
- **Condition:** Make sure that the card stock is not wrinkled, nicked, or otherwise damaged.
- **Size:** See “Supported media and capacity for input and output” on page 38.
- **Weight:** Card stock of 200 g/m² (53 lb) or less can be loaded in any tray. Card stock heavier than 200 g/m² (53 lb) must be printed from tray 1.

Note

When printing on card stock, make sure to set the `CARDSTOCK` type at the control panel when you load the tray, and in the printer driver when you print your print job.

Transparency specifications

To avoid damaging the printer, use only transparencies that are recommended for use in color laser printers.

- **Construction:** Prior to printing, transparencies should lie flat with less than 10 mm (0.39 inch) curl.
- **Condition:** Transparencies should not be wrinkled, nicked, or otherwise damaged.
- **Temperature:** Transparencies should be stable at 190° C (374° F), which is the printer fusing temperature.
- **Size:** 5 mm thick (0.005 inch)

Note

If problems occur while printing on transparencies, use tray 1. Send transparencies straight through the printer, entering at tray 1 and exiting from the face-up bin.

CAUTION

Transparencies used in the printer must be able to withstand 190° C (374° F), the printer fusing temperature.

Preprinted forms and special letterhead

Many preprinted forms and special letterhead papers perform well in HP LaserJet printers. However, these papers undergo processes that alter their original characteristics, and care must be taken to ensure they conform to HP specifications. All special papers should be wrapped in moisture-proof wrapping when purchased from the paper converter or printing house.

Forms and letterhead must be printed with inks that conform to the following specifications:

- Only use ink that is heat-resistant, and that will not melt, scorch, or release hazardous emissions when subjected to 200° C (392° F) for 0.1 second.
- Inks must have resistance to silicon oils, and must not be affected by resin components in toner.
- Inks must not be flammable.
- Inks must not “offset” (transfer from the printed paper onto the printer, contaminating internal printer components). The principle cause of offset is ink that is not fully dried or that cannot withstand the printer fusing temperature.

Note

Do not use forms or letterhead that was produced by using low-temperature inks (the kind used with thermography).

Embossed media

Embossed media is not recommended for use in HP LaserJet products. Media is embossed by stamping an image into the media by compressing the media fibers together at approximately 200° C (392° F), and sometimes by applying a thin metal foil to the surface. The product fusing process can loosen the foil; loose foil can interfere with the mechanical and electronic operation of the product.

Embossed paper, with or without foil, can also cause multifeed jams. Multiple embossed print media sheets tend to stick to one another.

Glossy media

Keep these considerations in mind when selecting or printing on glossy media:

- Print quality can vary with the media used. For best results, use HP-brand glossy media.
- When using media that has only one glossy side, make sure to orient the media so that the printer prints on the glossy side.

Note

When printing on glossy media that is between 75 g/m² (20-lb bond) and 105 g/m² (28-lb bond) in weight, make sure to set the `GLOSSY` type at the control panel when you load the tray, and in the printer driver when you print your print job.

When printing on HP-brand glossy media that is between 106 g/m² (29-lb bond) and 163 g/m² (43-lb bond) in weight, make sure to set the `HP HEAVY GLOSSY` type at the control panel when you load the tray, and in the printer driver when you print your print job.

When printing on non HP-brand glossy media that is between 106 g/m² (29-lb bond) and 163 g/m² (43-lb bond) in weight, make sure to set the `NON HP HEAVY GLOSSY` type at the control panel when you load the tray, and in the printer driver when you print your print job.

Media with cutouts or perforations

Avoid media with cutouts or perforations for these reasons:

- Cut fibers absorb more moisture and can increase waviness and media curl. This decreases the print quality near the cutout or perforated area.
- Cutting knives leave a sharp edge on the cutout or perforation. If the sharp edge is facing the print cartridge drum during printing, it can scratch the drum surface.
- If printing occurs over a cutout hole, the transfer roller is contaminated with unused toner, creating light streaks on the paper.

Chemically treated media

Coatings such as lacquers, polymers, laminations, or other chemicals protect the paper, but can cause problems in the fuser and transfer areas of HP LaserJet products. The surface resistivity and moisture content can be greatly altered, resulting in print-quality problems. Hard surface coatings increase wear on the rollers and media guides. All chemically treated media must meet Hewlett-Packard specifications for fusing compatibility.

Synthetic media

Synthetic media (those manufactured from man-made fibers) do not perform as well as bond media in any printer or MFP, especially HP LaserJet products. All synthetic media must meet Hewlett-Packard specifications, especially for caliper and fusing compatibility.

Other special media

- Non-standard sizes. Check minimum and maximum supported sizes on page 38.
- Carbonless media. Carbonless media (NCR) is not supported by HP LaserJet products.
- Recycled media. Choose recycled media that meets Hewlett-Packard specifications. Note that recycled media might not be as bright as indicated in the specifications. Hewlett-Packard recommends that recycled media contain no more than 5 percent groundwood. See “Testing media specifications” on page 45.

Storing print media

Ideally, the printing and media storage environment should be at or near room temperature, and should not be too dry or too humid. Remember that paper is hygroscopic; it absorbs and loses moisture rapidly.

Heat works with humidity to damage paper. Heat causes the moisture in paper to evaporate, while cold causes it to condense on the sheets. Heating systems and air conditioners remove most of the humidity from a room. As a paper package is opened and used, it loses moisture, causing streaks and smudging. Humid weather or water coolers can cause the humidity in a room to increase. As a package of paper is opened and used, it absorbs any excess moisture, causing light print and dropouts. Also, as paper loses and gains moisture, it can distort. This can cause jams.

Therefore, paper storage and handling are as important as the paper-making process itself. Paper storage environmental conditions directly affect the feed operation.

Users should not purchase more paper than can easily be used in a short time (about three months). Paper stored for long periods might experience heat and moisture extremes, which can cause damage. Planning is important to prevent damage to a large supply of paper.

Unopened paper in sealed packages can remain stable for several months before use. Opened packages of paper have more potential for environmental damage, especially if they are not wrapped with a moisture-proof barrier.

The paper storage environment should be correctly maintained to ensure optimum printer performance. The required condition is 20° to 24° C (68° to 75° F), with a relative humidity of 45 percent to 55 percent. The following guidelines should be helpful when evaluating the paper's storage environment:

- Paper should be stored at or near room temperature.
- The air should not be too dry or too humid (because of the hygroscopic properties of paper).
- The best way to store an opened package of paper is to rewrap it tightly in its moisture-proof wrapping. If the printer environment is subject to extremes, unwrap only the amount of paper to be used during the day's operation to prevent unwanted moisture changes.

Envelope storage

Proper storage of envelopes contributes to good print quality. Envelopes should be stored flat. If air is trapped in an envelope, and creates an air bubble, then the envelope might wrinkle during printing.

Testing media specifications

The following tests describe ways to evaluate media with respect to the specifications listed in this manual, and the *HP LaserJet Printer Family Print Media Guide*. See “Media assessment tools and suppliers” on page 50 for help obtaining the tools that are needed to perform these tests.

Basis weight field test

The basis weight should be indicated on the package label. If the label is not available, a simple field test can determine the basis weight of paper. The basis weight of paper is equal to the weight of 2,000 sheets of paper, or about four full packages. Weigh a full package on a postal scale and then multiply that weight by four. Or weigh 10 sheets of paper, divide that weight by 10, multiply by 2,000, and then divide by 16.

Example

10 sheets weigh 1.6 ounces ÷ 10
 0.16 ounce x 2,000 = 320 ounces
 320 ounces ÷ 16 ounce/lb = 20 lb paper (letter only)

Table 16. Determining basis weight of paper

Amount	Formula
Four packages	weight = basis weight
One package	weight x 4 = basis weight
10 sheets	(weight divided by 10) x 2,000 and then divided by 16 = basis weight

Metric sizes

For metric-size paper (A4), use the following method to determine basis weight.

Take 16 sheets of A4 paper and weigh them. One square meter of paper contains approximately 16 A4 size sheets. Compare this weight to the appropriate weight in the paper weight equivalence table.

Paper weight equivalence table

Use this table to determine approximate equivalent points in weight specifications other than U.S. bond weight. For example, to determine the equivalent of 20 lb U.S. bond-weight paper in U.S. cover-weight paper, locate the bond weight (in row 3, second column) and scan across the row to the cover weight (in the fourth column). The equivalent is 28 lb. Shaded areas indicate a standard weight for that grade.

Table 17. Paper weight equivalence

U.S. post-card thickness (mm)	U.S. bond weight (lb)	U.S. text/book weight (lb)	U.S. cover weight (lb)	U.S. bristol weight (lb)	U.S. index weight (lb)	U.S. tag weight (lb)	Europe metric weight (g/m ²)	Japan metric weight (g/m ²)
	17	43	24	29	35	39	64	64
	20	50	28	34	42	46	75	75
	21	54	30	36	44	49	80	80
	22	56	31	38	46	51	81	81
	24	60	33	41	50	55	90	90
	27	68	37	45	55	61	100	100
	28	70	39	49	58	65	105	105
	32	80	44	55	67	74	120	120
	34	86	47	58	71	79	128	128
	36	90	50	62	75	83	135	135
0.18	39	100	55	67	82	91	148	148
0.19	42	107	58	72	87	97	157	157
0.20	43	110	60	74	90	100	163	163

Table 17. Paper weight equivalence (continued)

U.S. post-card thickness (mm)	U.S. bond weight (lb)	U.S. text/book weight (lb)	U.S. cover weight (lb)	U.S. bristol weight (lb)	U.S. index weight (lb)	U.S. tag weight (lb)	Europe metric weight (g/m ²)	Japan metric weight (g/m ²)
0.23	47	119	65	80	97	108	176	176
	53	134	74	90	110	122	199	199
	54	137	75	93	113	125	203	203
	58	146	80	98	120	133	216	216
	65	165	90	111	135	150	244	244
	66	169	92	114	138	154	250	250
	67	171	94	115	140	155	253	253
	70	178	98	120	146	162	264	264
	72	183	100	123	150	166	271	271

Note

The U.S. postcard measurements are approximate. Use for reference only.

Caliper field test

The specified caliper differs according to the type of media used. Caliper can be measured in the field by using a micrometer.

CAUTION

Never use the coarse adjustment end of the micrometer when measuring for caliper. The coarse adjustment will compress the paper fibers, resulting in an inaccurate reading. For example, if the fibers are compressed, 6 mm (0.24 inch) paper could measure as little as 3 mm (0.12 inch). Always use the fine adjustment to measure caliper.

Using the fine adjustment, slide the micrometer along the edge of the paper and measure at one end. To double-check the accuracy of the reading, always measure again at the opposite end of the paper.

Paper finish field test

Paper finish, or smoothness, can be accurately measured with a Sheffield meter. If this tool is not available, a new U.S. dollar bill can be used as a benchmark for comparing paper texture. A dollar bill has a finish of 350 Sheffields. If paper feels rougher than a dollar bill, it is recommended that users do not continually use this paper in the printer.

Moisture content field test

Specification: Use paper with 4 percent to 6 percent moisture content.

A package or a sheet of paper can be measured with a moisture meter. In general, only evaluate customer storage environment when trying to determine if excess moisture or dryness is the cause of a problem with paper.

Grain field test

Grain direction is usually specified on the package label (written out “long” or “short”). The paper dimensions listed on the label also indicate grain direction. For example, short-grain letter-size paper labels are marked “11 by 8.5,” and long-grain paper labels are marked “8.5 by 11.”

If grain direction is not included on the package label, it can be determined by a simple wet test. Cut a small square from the corner of a sheet of paper, wet it, and observe the manner in which it curls.

Envelopes should have a diagonal grain, which gives them the best stability. To determine this, cut a square section from one corner of an envelope. Wet this section and observe the manner in which it curls. On diagonal grain envelopes, the two opposite corners will curl toward each other.

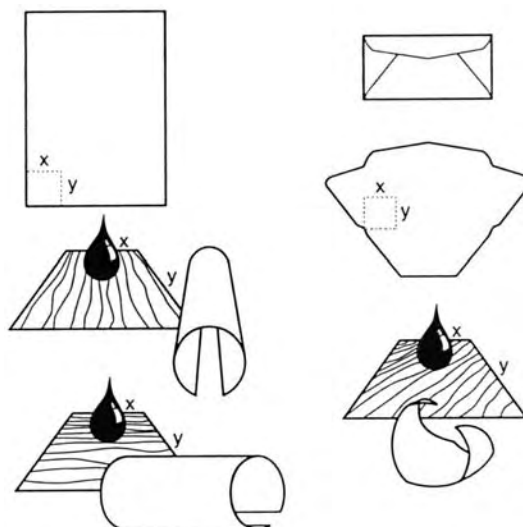

Figure 12. Long, short, and diagonal grain curl

Curl field test

To check for paper curl, place a single sheet of paper on a flat surface and measure curl at the greatest deflection, holding a ruler perpendicular to the flat surface.

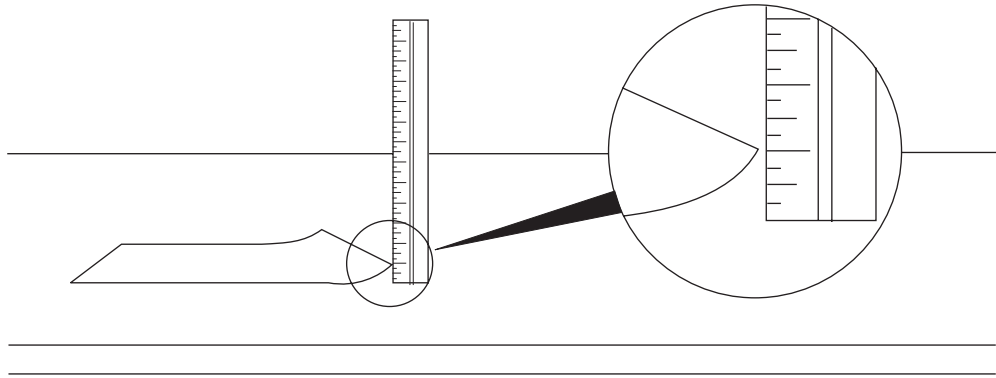

Figure 13. Measuring curl

Cut edge condition field test

The condition of the cut edge can be easily observed with an eye loop. Under magnification, a good edge will appear even. A poorly cut edge will show fraying, jagged edges, compressed fibers, and other damage.

Furnish (fiber composition) field test

Use paper made from 100 percent chemical wood pulp and/or cotton fiber. Recycled paper made with no more than 5 percent groundwood is also acceptable.

Read the package label to determine the fiber composition of the paper. Paper is usually specified as xerographic bond (suitable for copiers or laser printers) or cotton bond. Cotton bond paper of 25 percent, 50 percent, or 100 percent will be indicated on a watermark. If paper is less than 25 percent cotton bond, the watermark will not indicate a percentage. A wood pulp test kit can also be used to test fiber composition.

Fusing compatibility field test

Inspect the rollers for colored ink buildup from preprinted logos or letterhead, and for toner buildup or spots. Inspect printed output for repetitive defects and smearing. If necessary, have users contact the forms vendor to ensure paper fusing compatibility with HP LaserJet printers.

Media assessment tools and suppliers

Hewlett-Packard neither warrants nor recommends a particular manufacturer, supplier, or tool. Products are subject to change, and HP has no control over such changes. However, the following table of tools and their suppliers is provided for convenience.

Table 18. Tools and suppliers

Tool	Part Number	Supplier Address
Paper moisture meter	2RRDMP	Mitchell Instrument 1570DDD Cherokee St. San Marcos, CA 92069-2433
Single-sheet clamp probe	2R43E	Mitchell Instrument 1570DDD Cherokee St. San Marcos, CA 92069-2433
Temperature/humidity meter	#3T331	Industrial Motor Service 2000 Albright Montgomery, IL 60538
Sheffield tester: precisionaire column	TM 58-25-01	TMI Testing Machines Inc. 400 Bayview Avenue Amityville, NY 11701 (516) 842-5400
Sheffield tester: smooth check gauge	TM 58-25-02	TMI Testing Machines Inc. 400 Bayview Avenue Amityville, NY 11701 (516) 842-5400
Wood pulp test kit	4280-2	Shape Products 1127 57th Avenue Oakland, CA 94621 (800) 444-0015
pH test kit	4360-2	Shape Products 1127 57th Avenue Oakland, CA 94621 (800) 444-0015
Resistivity test tool: precision current/resistance meter	278	Monroe Electronics 100 Housel Avenue PO Box 100 Lyndonville, NY 14098 (800) 821-6001
Resistivity test tool: surface resistivity probe	96117-1	Monroe Electronics 100 Housel Avenue PO Box 100 Lyndonville, NY 14098 (800) 821-6001

2

Service approach

Chapter contents

Service approach	52
Parts and supplies	53
Ordering parts	53
Ordering supplies	53
Exchange program	53
Supplies	53
World Wide Web	53
HP service parts information compact disc	54
Customer care reseller sales and service support center	54
Ordering related documentation and software	55
Warranty	56
Limited warranty for print cartridge and image drum life	56
Transfer unit and fuser warranty	56
HP maintenance agreements	56
Onsite service agreements	57

Service approach

Note

This manual is used to service the entire HP color LaserJet 9500 Series printer and to service the HP color LaserJet 9500mfp *print engine* only. To service the ADF/scanner portion of the HP color LaserJet 9500mfp, see your *HP Scanner/ADF Service Manual for the HP LaserJet 9000mfp/9000Lmfp/9040mfp/9050mfp/9500mfp* (PN C8549-90955). To service the 2,000-sheet side-input tray, see your *2,000-sheet Side-Input Tray Service Manual* (PN Q1891-90901).

A complete service manual bundle is available by ordering the *Service Bundle for HP Color LaserJet 9500/9500mfp* (PN C8549-99001). The service bundle includes the manuals listed above, this print engine manual, and the *Paper Handling Accessories Service Addendum* (PN C85693-90002).

Throughout this document, the term “printer” is used to refer to both the HP LaserJet 9500 Series printer models *and* the HP LaserJet 9500mfp. Make sure to read the headings and text carefully to understand the context of the term.

The HP color LaserJet 9500 is designed to be diagnosed over the phone, and repaired in the field. Repair of the printer normally begins with a three-step process:

- 1 Isolate the problem to the major system (the host computer, the network or server, or the printer).
- 2 Isolate the problem to the print engine, the input device, the ADF/scan engine, or the finishing device. See the preceding note.
- 3 Troubleshoot a print-engine problem by using the troubleshooting procedures described in chapter 7 of this manual.

After a faulty part is located, repair is usually accomplished by assembly-level replacement of field replaceable units (FRUs). Some mechanical assemblies can be repaired at the subassembly level. Hewlett-Packard does not support replacement of components on the printed circuit assemblies. Some parts can be installed by the customer.

Parts and supplies

Ordering parts

Ordering Parts in chapter 8 of this manual contains FRU and replacement part numbers. Order replacement parts from Hewlett-Packard Customer Support-Americas (HPCS-A) or Hewlett-Packard Customer Support-Europe (HPCS-E).

All standard part numbers listed are stocked and can be ordered from HP's Customer Services and Support Organization. Use the following website to search for HP product parts by using the HP product name, model number, or part number, or by choosing an HP product from a list.

www.partsurfer.hp.com

To order parts, go to the following website:

www.hp.com/buy/parts

Consumables and accessories can be ordered from Hewlett-Packard.

Supplies, accessories, and consumables can be ordered from the following websites

- North America: www.hp.com/sbso/product/supplies
- Canada: www.hp.ca/catalog/supplies
- Europe: www.hp.com/go/supplies
- Asia Pacific: www.hp.com/paper

Ordering supplies

Order supplies directly from Hewlett-Packard. The following are phone numbers for ordering supplies:

- U.S. (1) (800) 538-8787
- Canada (1) (800) 387-3154; Toronto (1) (416) 671-8383
- United Kingdom 0734-441212

Exchange program

Hewlett-Packard might offer remanufactured assemblies for parts. These can be ordered through Parts Direct Ordering.

Supplies

Media and print cartridges can be ordered directly from Hewlett-Packard. See chapter 8 for ordering information.

World Wide Web

Printer drivers, updated HP printer software, and product and support information can be obtained from one of the following websites:

In the U.S.: www.hp.com/support/lj9500

Printer drivers can be obtained from the following sites:

- www.hp.com then select the appropriate country/region
- www.hp.com/go/lj9500_software

HP service parts information compact disc

This powerful, CD-ROM-based parts information tool is designed to give users fast, easy access to parts information such as pricing and recommended stocking lists for a wide range of HP products. To subscribe to this quarterly service in the U.S. or Canada, call (800) 336-5987. In Asia Pacific, call (65) 740-4484. Parts identification and pricing information can also be checked via the World Wide Web at www.partsurfer.hp.com.

Customer care reseller sales and service support center

The Customer Care Reseller Sales and Support Center is available to assist resellers and service technicians. To reach this support center, call (1) (800) 544-9976.

HP authorized resellers and support

To locate authorized HP resellers and support, call (1) (800) 243-9816 in the U.S. or (1) (800) 387-3867 in Canada.

HP service agreements

Call (1) (800) 743-8305 in the U.S. or (1) (800) 268-1221 in Canada.

Other areas

Outside of North America and Europe, contact the local HP sales office for assistance in obtaining technical support for resellers and service technicians.

Ordering related documentation and software

Table 19 shows where to order related documentation and software. Telephone numbers for the various sources are:

- HPCS-A:
(1)(800) 227-8164 (U.S. only)
- HPCS-E:
(49 7031) 14 2253
- HP Distribution Center (HPD) (661) 257-5565.
Fax: (805) 257-6995

Table 19. Related documentation and software

Description	Part number
HP LaserJet Family Print Media Guide	5963-7863
HP JetDirect Print Server Administrator's Guide	5971-3257
PCL/PJL Technical Reference Package	5021-0377

Note

End-user documentation is available electronically at <http://www.hp.com/support/lj9500>

Warranty

For warranty information and requirements, see the *HP color LaserJet 9500 Use Guide*.

Limited warranty for print cartridge and image drum life

This HP product is warranted to be free from defects in materials and workmanship during its useful life (end of life is indicated by a printer control panel low-life message).

This warranty does not cover products that have been modified, refurbished, remanufactured, misused, or tampered with in any way.

This limited warranty gives you specific legal rights. You may have other rights which vary from state to state, province to province, and country/region to country/region.

THE ABOVE WARRANTIES ARE EXCLUSIVE AND NO OTHER WARRANTY, WHETHER WRITTEN OR ORAL, IS EXPRESSED OR IMPLIED. THE HEWLETT-PACKARD COMPANY SPECIFICALLY DISCLAIMS THE IMPLIED WARRANTIES OR MERCHANTABILITY AND FITNESS FOR A PARTICULAR PURPOSE. TO THE EXTENT ALLOWED BY APPLICABLE LAW, IN NO EVENT SHALL HEWLETT-PACKARD COMPANY BE LIABLE FOR ANY INCIDENTAL, CONSEQUENTIAL, SPECIAL, INDIRECT, PUNITIVE, OR EXEMPLARY DAMAGES OR LOST PROFITS FROM ANY BREACH OF THIS WARRANTY OR OTHERWISE.

In the event that your product proves to be defective, please return to place of purchase with a written description of the problem.

Transfer unit and fuser warranty

This HP product is warranted to be free from defects in materials and workmanship for one year or until the product control panel indicates a low-life message, whichever occurs first.

This warranty does not cover products that have been modified, refurbished, remanufactured, misused, or tampered with in any way.

This limited warranty gives you specific legal rights. You may have other rights which vary from state to state, province to province, and country/region to country/region.

THE ABOVE WARRANTIES ARE EXCLUSIVE AND NO OTHER WARRANTY, WHETHER WRITTEN OR ORAL, IS EXPRESSED OR IMPLIED. THE HEWLETT-PACKARD COMPANY SPECIFICALLY DISCLAIMS THE IMPLIED WARRANTIES OR MERCHANTABILITY AND FITNESS FOR A PARTICULAR PURPOSE. TO THE EXTENT ALLOWED BY APPLICABLE LAW, IN NO EVENT SHALL HEWLETT-PACKARD COMPANY BE LIABLE FOR ANY INCIDENTAL, CONSEQUENTIAL, SPECIAL, INDIRECT, PUNITIVE, OR EXEMPLARY DAMAGES OR LOST PROFITS FROM ANY BREACH OF THIS WARRANTY OR OTHERWISE.

In the event that your product proves to be defective, please return to place of purchase with a written description of the problem.

HP maintenance agreements

Hewlett-Packard has several types of maintenance agreements that meet a wide range of support needs. Maintenance agreements are not part of the standard warranty. Support services may vary by area. Check with your local HP dealer to determine the services available to you.

Onsite service agreements

To provide you with the level of support best suited to your needs, HP offers the following onsite service agreements, with three response times.

- next business day onsite, HW support, four years
- next business day onsite, HW support, five years
- four-hour, 13 x 5 onsite, HW support, four years
- four-hour, 13 x 5 onsite, HW support, five years

For more information about HP service agreements, call (1) (800) 271-3113 (U.S.) or (1) (800) 268-1221 (Canada).

Priority onsite service

This agreement provides four-hour service response to your site for calls made during normal HP business hours.

Next-day onsite service

This agreement provides support by the next working day following a service request. Extended coverage hours and extended travel beyond HP's designated service zones are available on most onsite agreements (for additional charges).

Weekly (volume) onsite service

This agreement provides scheduled weekly onsite visits for organizations that own or lease many HP products. This agreement is designated for sites that use 25 or more workstation products, including printers, MFPs, plotters, computers, and disk drives.

3

Product configuration

Chapter contents

Printer control panel layout	60
Control panel menus	62
Menu map	62
Using a menu map	62
Retrieve job menu	63
Information menu	64
Paper handling menu	65
Selecting media for a document	66
Configure device menu	67
Printing submenu	67
PCL submenu	69
Print Quality submenu	70
System Setup submenu	75
Output Setup submenu	77
I/O submenu	77
Parallel Input submenu	77
EIO submenu	78
Resets submenu	80
Diagnostics menu	81
Service menu	86
Service ID	86
Restoring the Service ID	87
Converting the Service ID to an actual date	87
Settings and defaults	88
Configure the control panel display language	88
Configure the input trays	89
Boot key sequences	94
Hard disk reinitialization	94
NVRAM initialization	95
Cold reset	97

Printer control panel layout

Note

The control panel for the MFP is different from the printer control panel that is described in this section. See the *HP Scanner/ADF Service Manual for the HP LaserJet 9000mfp/9000Lmfp/9040mfp/9050mfp/9500mfp* (PN C8549-90955) for information about the MFP control panel.

The printer control panel includes three indicator lights; four navigation buttons; a help button; a PAUSE/RESUME button; a CANCEL JOB button; a numeric keypad; and a graphical display that shows up to four lines of text, supplies-status indicators, and printer animations.

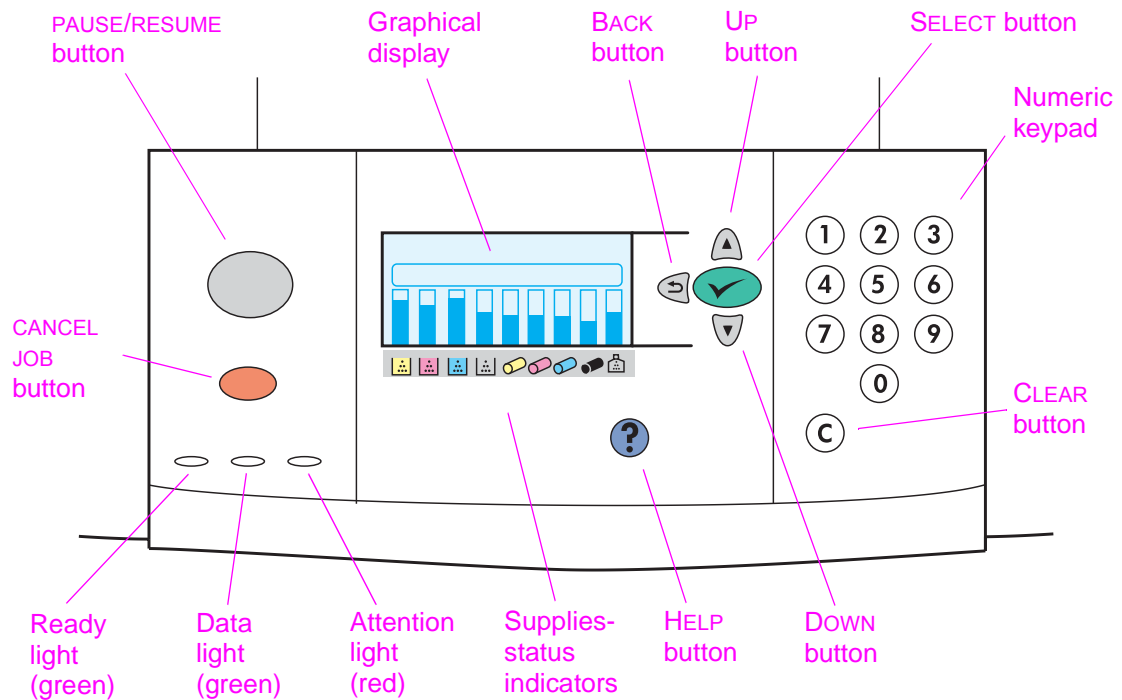

Figure 14. Control panel layout

Table 20. HP color LaserJet 9500 Series printer control panel features

Feature or key	Function
✓ (Select)	<ul style="list-style-type: none"> • Opens the main menu. • Saves the selected value for that item. An asterisk (*) appears next to the selection, indicating that it is the new default. The default settings remain when the printer is switched off or is reset (unless you restore the factory defaults from the RESETS menu). • Performs the action associated with the item that is highlighted on the graphical display.
↶ (Back)	<ul style="list-style-type: none"> • Backs up one level in the menu tree or clears a numeric value.
▲ (Up)	<ul style="list-style-type: none"> • Navigates to the previous item in the list.
▼ (Down)	<ul style="list-style-type: none"> • Navigates to the next item in the list.
C (CLEAR)	<ul style="list-style-type: none"> • Returns a numeric entry to its previous value.

Table 20. HP color LaserJet 9500 Series printer control panel features (continued)

Feature or key	Function
? (HELP)	<ul style="list-style-type: none">● Provides information about the current message on the graphical display.
CANCEL JOB STOP (MFP)	<ul style="list-style-type: none">● Cancels the current print job in process. The time it takes to cancel the job depends on the size of the print job.
PAUSE/RESUME	<ul style="list-style-type: none">● Returns the printer to the ready state (or to printing) from the menus or the online help.● Toggles between PAUSE and RESUME.
Numeric keypad	<ul style="list-style-type: none">● Can be used to type numeric values or menu shortcuts.

Control panel menus

Note

The control panel for the MFP has a physical and touch screen **MENU** button on the control panel that can be used to open the menus. For the MFP, use the **MENU** button in place of ✓ to open the menus. Also, the MFP **STOP** button is the equivalent of the **CANCEL JOB** button on the LJ 9500.

Press ▲ or ▼ to cycle through the control panel menus. Each menu is described in a separate table in this section. Menu items appear only if their associated option is installed, or if their functions are activated.

All menus and their associated items are available when the product is online. In menu mode, if no buttons are touched for approximately 30 seconds, the system automatically returns to the top level and displays either an existing error or one of the following items:

- **READY**, if the product is online.
- **OFFLINE**, if the product is offline.

Menu map

From the control panel, you can print a menu map that shows the current printer menus and settings. Additional menu items can appear in the control panel, depending on the options that are currently installed in the printer. The following is a list of menus available from the control panel, and where to find information about each.

- Retrieve job menu (page 63)
- Information menu (page 64)
- Paper handling menu (page 65)
- Configure device menu (page 67)
- Diagnostics menu (page 81)

Using a menu map

To see the current settings for the menus and items that are available in the control panel, print a control panel menu map. Values that appear with an asterisk (*) next to them are the currently selected values for a setting. Many of these values can be overridden from the print driver or a user software program.

The content of the menu map varies, depending on the optional accessories that are currently installed in the printer. For a complete list of accessories or to change a control panel item and possible values, see “Configure device menu” on page 67.

Select an item from the menu map

- 1 Press ✓ or **MENU** (MFP version).
- 2 Press ▲ or ▼ to scroll to the required menu, and then press ✓.
- 3 Press ▲ or ▼ to scroll to the appropriate page, and then press ✓.

Retrieve job menu

Note

If no private, stored, quick copy, or proof and hold jobs are on the product hard disk or in RAM memory, the message `NO STORED JOBS` appears when the Retrieve Job menu is selected.

Table 21. Retrieve job menu

Item	Explanation
USER 1 (X1) USER 2 (X2) USER 3 (X3) USER 4 (X4) USER 5 (X5) USER 6 (X6)	Use this item to see the job names for the username you select. The (X) notation tells you the number of stored print jobs for that user.
<USER NAME> ALL PRIVATE JOBS JOB 1 JOB 2 JOB 3 JOB 4	Use this item to select which print jobs to work with. Select the ALL PRIVATE JOBS option to see a list of all the print jobs for that user that require a PIN.
<JOB NAME> PRINT DELETE	Use this item to print or delete the selected job. If the job requires a PIN to be printed, P appears next to the PRINT command, and a PIN must be provided. If a job requires a PIN to be deleted, P appears next to the DELETE command, and a PIN must be provided. If you select PRINT, the printer prompts you to specify the number of copies to print (1 to 32,000)

Information menu

To select an information item, scroll to the page that you want and then press ✓ (LJ 9500), or touch the screen (LJ 9500mfp).

Table 22. Information menu

Item	Explanation
PRINT MENU MAP	Generates a menu map that shows layout and current settings of the control menu items. The printer backs up one screen to SET FRONT TO BACK when the page is completed.
PRINT CONFIGURATION	Generates a page that provides details about the current configuration of the printer. The printer returns to the online READY state when the page is completed.
PRINT SUPPLIES STATUS	Generates a page that shows the number of pages remaining for each supply in the printer. The printer returns to the online READY state when the page is completed.
SUPPLIES STATUS	Shows a scrollable list of supplies and the status of each supply on the control panel. The printer returns to READY when you exit the menu.
PRINT FILE DIRECTORY	Generates a directory page that contains information for all installed mass-storage devices. The directory page does not include information for the printer's ROM. The printer returns to the online READY state when the page is completed.
PRINT USAGE PAGE	Generates a page that contains information that could be used for cost accounting. This item is available only if a hard disk is installed. The printer returns to the online READY state when the page is completed.
PRINT DEMO	Generates a demonstration test page that describes printer features. The printer returns to READY when you exit the menu.
PRINT FILE DIRECTORY	Generates a page that lists the contents of the hard disk drive (if installed).
PRINT PCL FONT LIST	Generates a typeface list of all PCL fonts available on the printer. The printer returns to the online READY state when the page is completed.
PRINT PS FONT LIST	Generates a typeface list of all PS fonts available on the printer. The printer returns to the online READY state when the page is completed.
PRINT RGB SAMPLES	MFP only. Generates a set of RGB sample pages for color matching.
PRINT CMYK SAMPLES	MFP only. Generates a set of RGB sample pages for color matching.

Paper handling menu

When paper-handling settings are correctly configured through the control panel, you can print by selecting the type and size of media in the printer driver or software program.

Table 23. Paper handling menu default settings

Item	Values	Explanation
TRAY <N> SIZE=*ANY SIZE Tray 4 for the MFP is the 2,000-sheet side input tray, which only supports letter, A4, rotated letter, and rotated A4 media sizes.	*ANY SIZE LETTER LETTER ROTATED LEGAL EXECUTIVE 8.5X13 11X17 A3 A4 A4 ROTATED A5 B5<ISO> B5<JIS> B4<JIS> EXECUTIVE<JIS> DPOSTCARD<JIS> 8K 16K ENVELOPE #10 ENVELOPE MONARCH ENVELOPE C5 ENVELOPE DL ENVELOPE B5 CUSTOM ANY CUSTOM	Use this item to set the paper size for tray 1, tray 2, tray 3, and tray 4 (if installed). TRAY <N> indicates the appropriate tray number. Note ENVELOPE #10, ENVELOPE MONARCH, ENVELOPE C5, ENVELOPE DL, DPOSTCARD <JIS>, and ENVELOPE B5 appear for tray 1 only. Note ANY SIZE prints on any supported size of media, CUSTOM is used to configure a custom size specific to X and Y, and using ANY CUSTOM assumes that the maximum paper size is being used and prints on any size of media.
TRAY <N> TYPE=*ANY TYPE	*ANY TYPE PLAIN PREPRINTED LETTERHEAD TRANSPARENCY PREPUNCHED LABELS BOND RECYCLED COLOR LIGHT < 75 g/m ² HEAVY 106-163 g/m ² CARD STOCK > 164 g/m ² GLOSSY 75-105 g/m ² HEAVY GLOSSY NON HP HEAVY GLOSSY HIGH GLOSS IMAGES Note Some printers might require a firmware upgrade to support the HIGH GLOSS IMAGES setting. TOUGH PAPER ENVELOPE	Use this item to specify the type of media in each tray. TRAY <N> indicates the appropriate tray number. Note For the ANY TYPE value, the printer prints on the media that is loaded regardless of the media type that the driver requests. Note The media types might be mapped to different print modes in the CONFIGURE DEVICE, PRINT QUALITY, and PRINT MODE menu. Note Selecting a media type from this menu causes the printer to use the print mode that is assigned to requested paper type in the CONFIGURE DEVICE, PRINT QUALITY, PRINT MODES menu. See page 70. See table 27 on page 73 for a description of print modes and when to use them.

Table 23. Paper handling menu default settings (continued)

Item	Values	Explanation
TRAY <N> CUSTOM	UNIT OF MEASURE X DIMENSION Y DIMENSION	<p>This message appears when the custom switch is in the CUSTOM position and you select CUSTOM from the list of media sizes.</p> <p>The values listed are available in a pop-up menu from which you choose either millimeters or inches as the unit measure and also set the X and Y dimensions of the custom paper size.</p>

Selecting media for a document

See “Media specifications” on page 37 for more information.

Configure device menu

The configure device menu contains all of the administrative functions.

Printing submenu

Some items in this menu are available in a software program or the printer driver (if the appropriate printer driver is installed). Printer driver and software program settings override control panel settings.

Table 24. Configure device menu

Item and default setting	Values	Explanation
COPIES=1	1 TO 32,000	Set the default number of copies by specifying any number from 1 to 32,000. Use the numeric keypad to specify the number of copies. Note It is best to set the number of copies in the printer driver or software program. (Printer driver and software settings override control panel settings.)
DEFAULT PAPER SIZE= LETTER	LETTER LEGAL EXECUTIVE 8.5X13 11X17 A3 A4 A5 B5(ISO) B5(JIS) B4(JIS) EXECUTIVE(JIS) DPOSTCARD(JIS) 8K 16K ENVELOPE #10 ENVELOPE MONARCH ENVELOPE C5 ENVELOPE DL ENVELOPE B5 CUSTOM ANY CUSTOM	This value is used only if no paper size was sent with the job. Set the default size for which media and envelopes to print on if no size is selected for the print job. (The item name changes from media to envelope as you scroll through the available sizes.)
DEFAULT CUSTOM PAPER SIZE	UNIT OF MEASURE X DIMENSION Y DIMENSION	Use this item to set a custom paper size for any of the installed trays. This menu only appears when the selected tray custom switch is in the "custom" position. Select the X and Y dimensions of the custom paper size by using the ruler labels in the trays.
PAPER DESTINATION= STANDARD OUTPUT BIN	STANDARD OUTPUT FACE UP OPTIONAL BIN	Use this item to configure the output media bin destination. Only the installed bins appear on the menu.

Table 24. Configure device menu (continued)

Item and default setting	Values	Explanation
DUPLEX=OFF	OFF ON	<p>This item appears only when a duplexer is installed. Set the value to ON to print on both sides (duplex) or OFF to print on one side (simplex) of a sheet of paper.</p> <p>Note It is best to set the duplex option in the printer driver or software program. (Printer driver and software settings override control panel settings.)</p>
BINDING=LONG EDGE Note The menu item appears only if DUPLEX=ON.	LONG EDGE SHORT EDGE	<p>Use this item to change the binding edge for duplex printing.</p> <p>Note It is best to set the binding layout in the printer driver or software program. (Printer driver and software settings override control panel settings.)</p>
OVERRIDE A4/ LETTER=NO	YES NO	<p>Use this item to print on letter-size media when an A4 job is sent but no A4-size media is loaded in the printer (or to print on A4-size media when a letter job is sent but no letter-size media is loaded in the printer).</p>
MANUAL FEED=OFF	OFF ON	<p>Use this item to feed the media manually from tray 1 rather than automatically from another tray. When MANUAL FEED=ON and tray 1 is empty, the printer goes offline when it receives a print job. The message MANUALLY FEED [PAPER SIZE] then appears on the control panel.</p>
COURIER FONT=REGULAR	REGULAR DARK	<p>Use this item to select the version of Courier font to use:</p> <ul style="list-style-type: none"> ● REGULAR is the internal Courier font that is available on the HP LaserJet 4 Series and later printers. ● DARK is the internal Courier font that is available on the HP LaserJet III Series printers. <p>Both fonts are <i>not</i> available at the same time.</p>
WIDE A4=NO	YES NO	<p>The Wide A4 setting changes the number of characters that can be printed on a single line of A4 media.</p> <p>YES: Up to 80 10-pitch characters can be printed on one line. NO: Up to 78 10-pitch characters can be printed on one line.</p>
PRINT PS ERRORS=OFF	ON OFF	<p>Select ON to print the PS error page when PS errors occur.</p>
PCL		<p>Use this item to open PCL submenu items (see page 69).</p>

PCL submenu

Gain access to this submenu through the Printing submenu. Some items in this menu can be opened in a software program, or in the printer driver (if the appropriate printer driver is installed). Printer driver and software settings override control panel settings.

Note

If no private, stored, quick copy, or proof and hold jobs are on the printer hard disk or in RAM memory, the message `NO STORED JOBS` appears when the menu is selected.

Table 25. PCL submenu

Item and default setting	Values	Explanation
FORM LENGTH	60	Sets vertical spacing from 5 to 128 lines for the default media size. Type the value by using the numeric keypad.
ORIENTATION	PORTRAIT LANDSCAPE	Use this item to select default page orientation. Note It is best to set the page orientation in the printer driver or software program. (Printer driver and software settings override control panel settings.)
FONT NUMBER	INTERNAL SOFT SLOT 1 SLOT 2 SLOT 3	INTERNAL: Internal fonts. SOFT: Permanent soft fonts. SLOT 1, 2, or 3: Fonts stored in one of the three DIMM slots.
FONT SOURCES	0-999	The printer assigns a number to each font and lists them on the PCL Font List. The font number appears in the Font # column of the printout.
FONT POINT SIZE= 12.00	4.00 to 999.75	Use the numeric keypad or ▲ or ▼ to specify a value. This item might not appear, depending on the font selected.
SYMBOL SET=PC-8	PC-8	Select any one of several available symbol sets at the printer control panel. A symbol set is a unique grouping of all the characters in a font. PC-8 or PC-850 is recommended for line-drawn characters.
APPEND CR TO LF=NO	YES NO	Select YES to append a carriage return to each line feed encountered in some text print jobs. Some environments, such as UNIX, indicate a new line by using only the line feed control code. Use this option to append the required carriage return to each line feed.
SUPPRESS BLANK PAGES	YES NO	Use this item for customers creating their own PCL that might include extra form feeds which print blank pages. Select YES to ignore form feeds if the page is blank.

Print Quality submenu

Table 26. Print Quality menu

Item	Values	Explanation
ADJUST COLOR <ul style="list-style-type: none"> ● CYAN DENSITY ● MAGENTA DENSITY ● YELLOW DENSITY ● RESTORE COLOR VALUES 	-5 TO +5	<p>Use this item to control the midtones (solid and very light color fills are <i>not</i> affected) for each color plane. The default for each color is zero. A larger negative number can result in lighter or less dense midtones for a particular color plane, and a larger positive number can result in darker or more dense midtones for a color plane. Settings can be adjusted, for each color plane (cyan, magenta, yellow, and black), individually as primary transfer biases are charged.</p> <p>Note Newer versions of the printer version and the MFP version firmware allow the primary colors to be individually adjusted for highlight, midtone, and shadow ranges.</p> <p>Note The changes are universal, and apply to all printed pages regardless of the media type selected.</p> <p>Note The RESTORE COLOR VALUES menu returns the values to the default.</p>
SET REGISTRATION	PRINT TEST PAGE SOURCE ADJUST TRAY 1 ADJUST TRAY 2 ADJUST TRAY 3 ADJUST TRAY 4 (IF INSTALLED)	<p>Use this item to set the printed image at the center of a single-page or duplexed print job. The PRINT TEST option prints a test page. Use the SOURCE option to print a test page from all trays or from specified trays. Use the ADJUST TRAY X options to adjust the image alignment using values between -20 and +20.</p>
PRINT MODES	PLAIN PREPRINTED LETTERHEAD TRANSPARENCY PREPUNCHED LABELS BOND RECYCLED COLOR LIGHT<75 g/m ² HEAVY 106-163 g/m ² CARDSTOCK>164 g/m ² GLOSSY 75-105 g/m ² HEAVY GLOSSY NON HP HVY GLOSSY HIGH GLOSS IMAGES Note Some printers might require a firmware upgrade to support the HIGH GLOSS IMAGES setting. TOUGHPAPER ENVELOPE RESTORE MODES	<p>Use this item to associate print modes with individual media types in order to optimize print quality. For this menu option, the print mode can only be changed at the control panel.</p> <p>See the “Description” column in table 27, “Description of print modes” on page 73.</p>

Table 26. Print Quality menu (continued)

Item	Values	Explanation
OPTIMIZE	TRANSFER DOWN 1 TRANSFER DOWN 2 TRANSFER UP 1 TRANSFER UP 2 LEADING EDGE DOWN LEADING EDGE UP HIGH COVERAGE 1 HIGH COVERAGE 2 HIGH COVERAGE 3 RESTORE OPTIMIZE	<p>Use this item to optimize a number of engine parameters for all jobs rather than by media type. Each item can be set to OFF or ON. The default value of each item is OFF. Use the RESTORE OPTIMIZE option to reset all options to the factory default position (OFF).</p> <ul style="list-style-type: none"> ● TRANSFER DOWN 1, TRANSFER DOWN 2, TRANSFER UP 1, and TRANSFER UP 2: These settings control T2 current to correct for media types that show poor secondary transfer when a predefined media type setting is used. Try the DOWN 1 and DOWN 2 settings first. This might result in a darker image. If it does not, some medias require that the value is set to UP 1 or UP 2. It is possible to set these ON at the same time. If multiple bits are set, the default (all OFF) is used. Using smoother media results in better transfer; exceptionally rough media can show problems that will not be addressed by these settings. ● LEADING EDGE DOWN and LEADING EDGE UP: Use these settings to compensate for poor transfer, missing toner, discharge marks, and mottled appearance on the leading edge of printed pages. To resolve these issues, try setting LEADING EDGE DOWN first; however depending on the media type, you might get better results using LEADING EDGE UP. LEADING EDGE UP set to ON increases the leading edge secondary transfer bias. LEADING EDGE DOWN set to ON decreases the leading edge secondary transfer bias. If the UP and DOWN settings are both set to ON, they are set to OFF. <p>Note Try the other media type settings first, because this is a universal setting and applies to all pages that are printed, regardless of the selected media type.</p> <ul style="list-style-type: none"> ● HIGH COVERAGE 1, HIGH COVERAGE 2, and HIGH COVERAGE 3: HIGH COVERAGE 1 and HIGH COVERAGE 2 control the setting of the yellow dot pattern that is designed to eliminate certain types of banding (47 mm) in high coverage. <ul style="list-style-type: none"> • HIGH COVERAGE 1: Yellow dots appear in a 10-by-10 mm pattern for half-speed printing, and an 8-by-8 mm pattern for full-speed printing. The default is OFF; when set to ON, the yellow dots are off. If the yellow dots are objectionable and the 47 mm band is acceptable (a line or band is visible once at 47 mm from the start and the stop of a strip of color), turn this item ON. Otherwise, leave this item OFF. • HIGH COVERAGE 2: Yellow dots appear in an 8-by-8 mm pattern for full-speed printing, and 10-by-10 mm for half-speed printing. The default is OFF; when set to ON, the yellow dots are in an 8-by-8 mm pattern for half- and full-speed printing. If a line recurs every 47 mm from the start of a strip in half-speed printing modes, turn this item ON. Otherwise, leave this item OFF.

Table 26. Print Quality menu (continued)

Item	Values	Explanation
OPTIMIZE (continued)		<ul style="list-style-type: none"> ● High coverage 3 helps with 50 mm to 100 mm bands or cardstock band (37 mm from the trailing edge of 11-by-17 [A3] or 115 mm from the trailing edge of letter [A4] on media that is heavier than 120 g/m²) <ul style="list-style-type: none"> • HIGH COVERAGE 3: This changes the OPC ITB speed mismatch (101.5 percent [OFF] to 102 percent [ON]). The default is OFF. If a line or band recurs at 50 or 100 mm intervals (37 mm from the trailing edge of 11-by-17 (A3) and 115 mm from the trailing edge of letter (A4) on media heavier than 120 g/m²), turn this item ON for half-speed media types. Do <i>not</i> change this setting to ON unless the bands are very objectionable. If you do this 47 mm banding might increase.
CALIBRATE NOW		<p>Select CALIBRATE NOW to start a printer calibration (D-max, D-half, and CPR calibrations are performed).</p> <p>Note The MFP includes a QUICK CALIBRATE NOW option that takes less time to calibrate the product (the CPR calibration is not performed).</p>
PROCESS CLEANING PAGE		<p>Use this item to print a single blank page that might help clean the fuser rollers after a fuser-related jam.</p>

Table 27. Description of print modes

Print mode	Media type(s) that use this mode by default	Speed	Description	When to use
AUTO SENSE MODE	plain	trans: half opaque: full	Optimized for the media that is detected. If a transparency is detected, printing does not stop, and the correct printing attributes are used for the transparency.	If transparencies are not frequently used in the printer.
AUTO SENSE OFF	preprinted, letterhead, prepunched, bond, recycled, and color	full	Prints on whatever media is in the tray (if a transparency is detected, printing stops and the message UNEXPECTED TYPE IN TRAY X appears).	If transparencies are frequently used in the printer. This mode minimizes the occurrence of unintentional printing on transparencies.
LIGHT MODE	light < 75 g/m ²	full	Optimized for light media 60 to 74 g/m ² .	Use for light media.
HEAVY MODE	heavy (106 to 163 g/m ²)	half	<ul style="list-style-type: none"> Optimized for heavy media 106 to 163 g/m². The printer engine operates at half-speed to provide enough heat to correctly fuse the image because heavy media has more mass to heat. 	Use for heavy media.
CARDSTOCK MODE	cardstock > 164 g/m ²	half	<ul style="list-style-type: none"> Optimized for card stock heavier than 164 g/m². The printer engine operates at half-speed to provide enough heat to correctly fuse the image because heavy media has more mass to heat. 	Use for cardstock.
TRANSPARENCY MODE	transparencies	half	<ul style="list-style-type: none"> Optimized for transparencies. The printer engine operates at half-speed to produce a smoother, flatter image that transmits light better. 	Use for transparencies.
ENVELOPE MODE	envelopes	full	Optimized for envelopes.	Use for envelopes.
LABEL MODE	labels	half	<ul style="list-style-type: none"> Optimized for labels. The printer engine operates at half-speed to provide enough heat to correctly fuse the image. 	Use for labels.
HIGH GLOSS IMAGES	heavy glossy	half	Optimized for heavy, glossy HP media (105 to 163 g/m ² [28- to 43-lb bond]).	Use for heavy glossy media. Note Use this image mode when printing high color saturation images, or images that look better with saturated, vivid colors.
GLOSSY MODE	glossy 75 to 105 g/m ²	full	Optimized for glossy media (75 to 105 g/m ² [20- to 28-lb bond]).	Use for normal glossy media.
HEAVY GLOSSY MODE	heavy glossy	half	Optimized for heavy, glossy HP media (105 to 163 g/m ² [28- to 43-lb bond]).	Use for heavy glossy media.

Table 27. Description of print modes (continued)

Print mode	Media type(s) that use this mode by default	Speed	Description	When to use
NON HP HEAVY GLOSSY MODE	non-heavy glossy	half with pauses	Optimized for heavy, glossy non-HP media (105 to 163 g/m ² [28- to 43-lb bond]).	Use for non-HP heavy glossy media.
TOUGH PAPER MODE	tough paper	half with pauses	Optimized for glossy film media.	Under normal conditions.
BEST GLOSS MODE	not associated with a media type by default	full with pauses	Pauses printing if the fuser temperature decreases in order to maintain a higher fuser temperature and consistent gloss level.	If you notice changes in print quality when using glossy media, associate the GLOSSY type with this print mode.
BEST HP GLOSS MODE	not associated with a media type by default	half with pauses	Pauses printing if the fuser temperature decreases in order to maintain a higher fuser temperature and consistent gloss level.	If you notice changes in print quality when using HP heavy, glossy media, associate the HEAVY GLOSSY type with this print mode.
BEST NON HP GLOSS MODE	not associated with a media type by default	half with pauses	Pauses printing if the fuser temperature decreases in order to maintain a higher fuser temperature and consistent gloss level.	If you notice changes in print quality when using heavy glossy, media, associate the NON HP HEAVY GLOSSY type with this print mode.
BEST TOUGH PAPER MODE	not associated with a media type by default	half with pauses	Pauses printing if the fuser temperature decreases in order to maintain a higher fuser temperature and consistent gloss level.	If you notice changes in print quality when using HP heavy, glossy media, associate the TOUGH PAPER type with this print mode.
TONER MODE	not associated with a media type by default	full	<ul style="list-style-type: none"> ● Uses less toner in order to reduce toner scatter. ● TONER MODE uses a lower density color table for high-resistivity media to avoid toner explosions by applying less toner on a page. 	If you are using rough or poor-quality media, and you have noticed toner scatter on your print jobs, associate the media type with this mode.
BLISTERS MODE	not associated with a media type by default	full with pauses	Operates at full-speed but pauses, usually during the first few pages of a print job, to keep the fuser hot. If the fuser is not hot enough gloss can drop and cause the toner to blister with light media.	Use with plain media only. If you notice changes in print quality when using heavy glossy media, associate the PLAIN type with this print mode.
RESTORE MODES			Resets all of the print modes to the factory defaults.	Use this setting to reset all of the print modes to the factory defaults.

System Setup submenu

Items in the System Setup submenu affect the printer function. Configure the printer according to your printing needs.

Table 28. System Setup submenu

Item and default setting	Values	Explanation
JOB STORAGE LIMIT=32	1 TO 100	Use this item to specify the number of jobs that can be stored on the printer hard-disk accessory.
JOB HELD TIMEOUT=OFF	OFF 1 HOUR 4 HOURS 1 DAY 1 WEEK	Use this item to set the amount of time that quick copy, proof and hold, private, and stored jobs are kept before being automatically deleted from the queue.
SHOW ADDRESS	AUTO OFF	Define whether or not the printer's IP address appears on the control panel with the READY message. If AUTO is selected, the IP address of the device is shown if the device is connected to a network.
OPTIMUM SPEED/COST	AUTO SPEED COST PER PAGE	Controls how the engine switches from color mode to monochrome mode. AUTO maps to the default option (SPEED for the HP color LaserJet 9500), SPEED maps to LOOK AHEAD (the printer only switches to mono mode if the next three pages are also only black), and COST PER PAGE maps to ALWAYS SWITCH (the printer switches modes for every page that is different).
TRAY BEHAVIOR	USE REQUESTED TRAY MANUALLY FEED PROMPT	Use this item to specify the behavior of the trays. Each of the options opens its own submenu: USE REQUESTED TRAY <ul style="list-style-type: none"> ● EXCLUSIVELY. The printer does not automatically select another tray when you indicate that a specific tray should be used. ● FIRST. The printer pulls media from another tray if the specified tray is empty. MANUALLY FEED PROMPT <ul style="list-style-type: none"> ● ALWAYS. You are prompted to insert media and press ✓ (the 6 button on the MFP) before printing begins. ● UNLESS LOADED. You are prompted only if tray 1 is empty.
POWERSAVE TIME=1 HOUR Note For an MFP, this item is named SLEEP DELAY.	1 MINUTE 15 MINUTES 30 MINUTES 60 MINUTES 90 MINUTES 2 HOURS 4 HOURS Note An MFP has a 45 MINUTES setting option.	Use this item to set how long the printer remains idle before it enters PowerSave mode. PowerSave mode offers the following advantages: <ul style="list-style-type: none"> ● minimizes the amount of power consumed by the printer when it is idle ● reduces wear on the printer electronic components (turns off the display backlight) The printer automatically exits PowerSave mode when you send a print job, press a control panel button, open a tray, or open any door. Note PowerSave turns off the backlight on the display, but the display is still readable.

Table 28. System Setup submenu (continued)

Item and default setting	Values	Explanation
PERSONALITY= AUTO	AUTO PCL POSTSCRIPT PDF	Use this item to select the default printer language (personality). Possible values are determined by which valid languages are installed in the printer. Normally, you should not change the printer language (the default is <code>AUTO</code>). If you change it to a specific printer language, the printer does not automatically switch from one language to another.
CLEARABLE WARNINGS=JOB	ON JOB	Use this item to set the amount of time that a clearable warning appears on the printer control panel. <code>ON</code> : Warning messages appear on the control panel until ✓ (the 6 button on the MFP) is pressed. <code>JOB</code> : Warning messages appear on the control panel until the end of the job from which they were generated.
AUTO CONTINUE= ON	ON OFF	Use this item to determine how the printer reacts to errors. <code>ON</code> : If an error prevents printing, the message appears and the printer goes offline for 10 seconds before returning online. <code>OFF</code> : If an error prevents printing, the message remains on the display, and the printer does not print until ✓ (the 6 button on the MFP) is pressed. Note To stop printing when an installed finishing device is out of staples, set <code>AUTO CONTINUE=OFF</code> .
SUPPLIES LOW= CONTINUE	CONTINUE STOP	Use this item to determine how the printer functions when sensors report a low-supply situation. <code>CONTINUE</code> : The printer continues to print while the <code>SUPPLIES LOW</code> message appears. <code>STOP</code> : The printer goes offline and waits for further action.
JAM RECOVERY= AUTO	AUTO ON OFF	Use this item to determine how the printer functions when a jam occurs. <code>AUTO</code> : The printer automatically selects the best mode for the printer jam recovery (usually <code>ON</code>). This is the default setting. <code>ON</code> : The printer automatically reprints pages after a jam is cleared. <code>OFF</code> : The printer does not reprint pages following a jam. Printing performance might be increased with this setting.
RAM DISK=AUTO Note Appears only if the hard disk drive is installed.	AUTO OFF	Use this item to determine how the RAM disk is configured. This item appears only if no optional hard disk is installed and the printer has at least 8 MB of memory. <code>OFF</code> : The RAM disk is disabled. Note If the setting is changed from <code>OFF</code> to <code>AUTO</code> , the printer automatically reinitializes when it becomes idle.
LANGUAGE= ENGLISH		Includes all languages in the list. When scrolling through the languages values, <code>LANGUAGE=</code> should be updated so it is presented in the highlighted language.
COLOR SUPPLY OUT HP CLJ 9500mfp only	OFF AUTO CONTINUE BLACK	If this item is set to <code>AUTO CONTINUE BLACK</code> , the MFP will continue to print jobs using the black print cartridge when a color cartridge (or cartridges) is out of toner.

Output Setup submenu

Table 29. Output Setup submenu

Item	Values	Explanation
OUTPUT SETUP (VARIES ACCORDING TO FINISHING DEVICE)		The Output Setup submenu appears when the printer has a 3,000-sheet stapler, 3,000-sheet stapler/stacker, or multifunction finisher attached. The menu items and values vary according to which finishing device is installed.

I/O submenu

Items in the I/O (input/output) submenu affect the communication between the printer and the computer.

Table 30. I/O submenu

Item and default setting	Values	Explanation
I/O TIMEOUT=15	5 TO 300	Select the I/O timeout period in seconds. (The I/O timeout refers to the time, measured in seconds, that the printer waits before ending a print job.) Use this setting to adjust the timeout for the best performance. If data from other ports appears in the middle of your print job, increase the timeout value.

Parallel Input submenu

Table 31. Parallel Input submenu

Item and default setting	Values	Explanation
HIGH SPEED=YES	YES NO	The printer accepts faster parallel communications that are used for connections with newer computers.
ADVANCED FUNCTIONS=ON	ON OFF	Turn the bidirectional parallel communication on or off. The default is set for a bidirectional parallel port (IEEE-1284). This setting allows the printer to send status readback messages to the computer. (Turning the parallel advanced functions on might slow the language switching.)

EIO submenu

The EIO (enhanced input/output) submenu appears only when an EIO device, such as an HP Jetdirect print server, is installed in an EIO slot on the printer. The items in the menu depend on the particular finishing device that is installed. If the printer contains an HP Jetdirect print server EIO card, you can configure basic networking parameters by using the EIO menu. These and other parameters can also be configured through HP Web Jetadmin or other network configuration tools (such as Telnet or the embedded Web server).

Table 32. EIO submenu

Item	Values	Explanation
TCP/IP	ENABLE HOST NAME CONFIG METHOD	<p>Use ENABLE to select whether the TCP/IP protocol is enabled (ON) or disabled (OFF).</p> <p>HOST NAME is an alphanumeric string, up to 32 characters in length that identifies the device. This name is listed on the Jetdirect page. The default host name is NPLxxxxxx, where xxxxxx is the last six digits of the LAN hardware (MAC) address.</p> <p>Use CONFIG METHOD submenu to select whether the TCP/IP configuration parameters are set automatically from a network server by using any of these methods:</p> <ul style="list-style-type: none"> ● BOOTP (Bootstrap Protocol) ● DHCP (Dynamic Host Configuration Protocol). If selected, and if a DHCP exists, the DHCP RELEASE and DHCP RENEW menus are available to set lease options. ● MANUAL. Provides access to parameters that can be manually configured at the printer control panel. If selected, the MANUAL SETTINGS menu is available to configure the parameters.
IPX/SPX	ENABLE FRAME TYPE SOURCE ROUTING	<p>Use the ENABLE submenu to select whether the IPX/SPX protocol is enabled (ON) or disabled (OFF).</p> <p>Use FRAME TYPE to select the frame type setting for your network. The frame submenu includes these values:</p> <ul style="list-style-type: none"> ● AUTO (default) automatically sets and limits the frame type to the first one detected. ● EN_8023, EN_II, EN_8022, and EN_SNAP are the frame type selections for Ethernet networks. ● TR_8022, TR_SNAP are the frame type selections for Token Ring networks. <p>The SOURCE ROUTING submenu is for a Token Ring network only. Use it to specify the NetWare Token Ring Source Routing parameter from the following options.</p> <p>AUTO (default): The type of source routing that is required on the network is automatically sensed.</p> <p>OFF: All packets are sent without source routing, and only packets from the same ring are received.</p> <p>ALL ROUTES and SINGLE ROUTES: All packets are sent with source routing (broadcasts and when the route is unknown).</p>
APPLETALK	ENABLE	(Ethernet and Fast Ethernet only) Use this item to select whether the AppleTalk protocol is enabled (ON) or disabled (OFF).
DLC/LLC	ENABLE	Use this item to select whether the DLC/LLC protocol stack is enabled (ON) or disabled (OFF).

Table 32. EIO submenu (continued)

Item	Values	Explanation
LINK SPEED	AUTO 10T HALF 10T FULL 100THALF 100TFULL	(For 10/100Base-TX print servers only) Use this item to select the network link speed and communication mode for the 10/100Base-TX print server. For proper communications, the Jetdirect settings must match the network. AUTO (default): The print server will automatically configure itself to match the network's link speed and communication mode. If it fails, 100TX HALF is set. 10T HALF: 10Mbps, half-duplex operation 10T FULL: 10 Mbps, full-duplex operation 100T HALF: 100 Mbps, half-duplex operation 100T FULL: 100 Mbps, full-duplex operation
SECURE WEB	HTTPS REQUIRED HTTPS OPTIONAL	For configuration management, specify whether the embedded Web server will accept communications using HTTPS (Secure HTTP) only, or both HTTP and HTTPS. HTTPS REQUIRED (default): For secure, encrypted communications, only HTTPS access is accepted. The print server will appear as a secure site. HTTPS OPTIONAL: Access using either HTTP or HTTPS is permitted.
RESET SECURITY	NO YES	Specify whether the current security settings on the print server will be saved or reset to factory defaults. NO (default): The current security settings are maintained. YES: Security settings are reset to factory defaults.

Resets submenu

The items in the Resets submenu clear all memory in the printer, while **CANCEL JOB** (the **STOP** button on the MFP) clears only the current job.

Reset the printer only under the following circumstances:

- you want to restore the printer default settings
- communications between the printer and computer has been interrupted
- you are having problems with a port

Note

Use this menu with caution. You can lose buffered page data or printer configuration settings when you select these items.

Table 33. Resets submenu

Item	Explanation
RESTORE FACTORY SETTINGS	This item restores most of the factory (default) settings. This item also clears the input buffer for the active I/O. Resetting memory during a print job can result in data loss. This items does not affect network settings that are stored on the HP Jetdirect print server (if installed).
CHARGER CLEANED	This item notifies the printer that the post charger is cleaned.
CLJ 9500: POWERSAVE CLJ 9500mfp: SLEEP MODE	CLJ 9500: Use this item to set the sleep mode option. The three settings are OFF, LOW, and HIGH. OFF: Powersave function is off. LOW: Uses more power than the HIGH setting, but the printer reaches the Ready state more quickly. HIGH: This setting saves the most power, but the printer takes longer to reach the Ready state. CLJ 9500mfp: The two settings are OFF and ON (ON is the default setting).
RESET SUPPLIES	This item notifies the printer that a new supply kit is installed. Only supplies that the printer cannot detect as changed appear (new cleaning kit, new transfer kit, and new fuser kit).

Diagnostics menu

Note

If the printer or MFP is in a product-checking state (for example, during an engine rotation or when coming out of sleep mode) you must wait before attempting to start a diagnostic.

You can use this submenu to isolate parts, and to troubleshoot jam and print-quality issues. See “Engine diagnostic tools” on page 337 in chapter 7 for more information about using these diagnostic tools.

Table 34. Diagnostics menu

Item	Values	Explanation
PRINT EVENT LOG	Prints a page that indicates the most recent printer errors.	Use this item to generate a localized FIFO (first in, first out) list of the 50 most recent entries in the error log. The printed event log shows the error number, page count, error code, and description or personality.
SHOW EVENT LOG	Displays on the control panel a list of the most recent printer errors.	Use this item to scroll through the contents of the event log at the control panel, and to show the 50 most recent events. Use ▲ and ▼ to scroll through the event log contents.
PQ TROUBLESHOOTING	Prints a series of pages that are useful to identify print quality problems (follow the printed instructions).	Use this item to print eight pages to help you identify print-quality problems. The eight pages consist of two pages of instructions, one page for each color (cyan, magenta, yellow, and black), one demo page, and one configuration page.
DISABLE CARTRIDGE CHECK	Prints with one or more image drums removed.	Use this item to isolate defective cartridges by first removing specific image drums, and then printing internal pages or a print job using the remaining image drums.
PAPER PATH TEST	PRINT TEST PAGE SOURCE DESTINATION DUPLEX COPIES SENSORS	<p>NOTE The MFP does not use the sensors option in this test. To test MFP sensors, see PAPER PATH SENSORS for the HP LJ 9500mfp in this table.</p> <p>Use this item to generate a test page that is useful for troubleshooting the printer’s paper-handling features.</p> <p>Define the test based on the media source, the output destination, duplex ON or OFF, the number of copies, or if the paper-path sensor status appears on the control panel during the test by selecting any of the options, and then select PRINT TEST PAGE to perform the test.</p> <p>If the SENSORS value is selected, the status of the following sensors appears on the control panel (SENSORS is not an available selection for an MFP; for an MFP, see SENSOR TEST in this table):</p> <ul style="list-style-type: none"> ● A: Tray 2 feed A ● B: Tray 2 feed B ● C: Tray 3 feed A ● D: Tray 3 feed B ● E: Pre-registration ● F: Pre-T2 ● G: Pre-fuser ● H: Fuser outlet ● I: Duplex reverse ● J: Duplex feed ● K: Face-down output

Table 34. Diagnostics menu (continued)

Item	Values	Explanation
<p>SENSOR TEST (Interactive)</p>	<p>Note A through K appear on the control panel.</p> <ul style="list-style-type: none"> ● A: Pre-registration ● B: T2 ● C: Paper path ● D: Fuser outlet ● E: Face-down outlet ● F: Face-down capacity full ● G: Tray 1 media presence ● H: Tray 2 media presence ● I: Tray 2 feed sensor A and B ● J: Tray 2 X dimension (cross feed direction) ● K: Tray 2 Y dimension (cross feed direction) ● L: Tray 3 media presence ● M: Tray 3 feed sensor A and B ● N: Tray 3 X dimension (cross feed direction) ● O: Tray 3 Y dimension (feed direction) ● P: Lower right door ● Q: Right front/upper right door interlock ● R: Left front/lower left door interlock ● S: Upper left door 	<p>Use this item to manually test paper-path sensors and switches for correct operation. When the sensors are manually toggled, the control panel displays the sensor switching from ON to OFF, and from OFF to ON.</p> <p>Note: For an MFP, the I and O values are not an available selection.</p>
<p>PAPER PATH SENSORS (HP LJ 9500mfp only)</p>	<p>Note A through N appear on the control panel I is omitted).</p> <ul style="list-style-type: none"> ● A: Upper cassette feed A ● B: Upper cassette feed B ● C: Lower cassette feed A ● D: Lower cassette feed B ● E: Pre-registration ● F: Pre-T2 ● G: Pre-fuser ● H: Fuser outlet ● J: Duplex reversed ● K: Tray 2 Y dimension (cross-feed direction) ● M: Media sensor (not OHT = 0, OHT = 3) ● N: Media-type-mismatch indication 	<p>This item allows you to monitor the activation of the paper path sensors using the control-panel display, as a sheet is being fed.</p> <p>NOTE The STOP button cancels this test. Sensors in tray 4 or the 2,000-side input feeder are not tested with this diagnostic.</p> <p>When the MFP is in this mode, any printed page (internal or from a host PC) can be used for the test.</p>

Table 34. Diagnostics menu (continued)

Item	Values	Explanation
COMPONENT TEST	TRANSFER MOTORS BELT ONLY IMAGE DRUM MOTORS CARTRIDGE MOTORS DEVELOPER MOTORS YELLOW LASER SCANNER MAGENTA LASER SCANNER CYAN LASER SCANNER BLACK LASER SCANNER FUSER MOTOR MP PAPER FEED DRIVE UPPER CASSETTE FEED DRIVE LOWER CASSETTE FEED DRIVE PREREGISTRATION REGISTRATION FACE UP SOLENOID REPEAT	<p>NOTE You must defeat the right-door interlock before selecting the BELT ONLY component test, so that the ITB can be seen.</p> <p>For the MFP, you must defeat the right-door interlock before selecting the <COLOR> LASER SCANNER component test and place your ear near the print cartridge to hear the scanners rotate.</p> <p>For the MFP, you must remove the finishing device before selecting the FUSER MOTOR test.</p> <p>For the MFP, you must remove the 2,000-sheet side input feeder before selecting the MP PAPER FEED DRIVE test.</p> <p>Component tests exercise individual parts independently to help you isolate failures, noises, print quality problems, and other issues. The results of the test depend on your observation of the printer during the test to determine the source of the problem.</p> <p>When you select one of the components for testing, the printer goes offline and runs the test based on the REPEAT value. Depending on the component that you select, you might be prompted to remove parts from the printer. If you do not remove the correct parts or if you press the CANCEL JOB button (the STOP button on the MFP), the display returns to the Diagnostics menu. When the test is complete, the control panel also returns to the Diagnostics menu. The REPEAT value allows the test to operate once continuously.</p> <p>Note See table 35 for more information about the COMPONENT TEST values.</p> <p>Note Several of the engine diagnostics require certain pre-conditions to operate. See "Engine diagnostics preconditions" on page 338 in chapter 7.</p>

Table 34. Diagnostics menu (continued)

Item	Values	Explanation
PRINT/STOP TEST	<p>Note The operator is prompted to enter a stop time value.</p> <p>Suggested delay times (using letter media):</p> <ul style="list-style-type: none"> ● 0 to 3,000 ms: Earliest page-stop point (60 mm from the top left side of the lower access door) ● 1,000 ms: T1 - Y on belt ● 1,500 ms: T1 - M on belt ● 2,000 ms: T1 - C on belt ● 3,000 ms: T1 - K on belt ● 4,000 ms: ITB image at post charger ● 4,100 ms: Page at pre-registration ● 4,500 ms: ITB image is complete for all colors (CMYK) ● 5,000 ms: Page at registration (buckled) ● 7,000 ms: ITB image and page at mid-secondary transfer ● 7,500 ms: Page just prior to duplex diverter ● 8,000 ms: Page at mid-fuser ● 8,500 ms: Two-third of ITB image cleaned ● 12,500 ms: Page partially delivered to face-down tray 	<p>Use this item to isolate print quality problems and media handling faults by stopping the printer in the middle of a print cycle to observe the point in the process where the image degrades, or where media jams or is damaged. The range is 0 to 60,000 milliseconds, in increments of 10.</p> <hr/> <p>Note</p> <p>One millisecond equals about 0.15 mm (0.0006 inch) of media travel. Sixty-six milliseconds equals about 10 mm (0.4 inch) of media travel.</p>
COLOR BAND TEST	PRINT TEST PAGE COPIES	<p>Use this item to identify arcing in the high-voltage paths and to isolate print-quality problems to the primary or the secondary transfer areas. The test prints a bar pattern that contains primary and secondary colors. The Color Band Test page should be printed on 11-by-17 or A3 media, if available. If not, letter or A4 media should be used (the larger media is used if it is set as the default media size).</p> <p>Evidence of arcing might not appear until a series of pages has been printed. Use the COPIES option to control how many copies of the internal page to print. The range is 1 to 30.</p>

Table 35. Component test values

Value	Explanation
TRANSFER MOTORS	Use this item to check the four OPC drive motors and the ITB motor without any other printer process operating.
BELT ONLY	Use this item to check the ITB motor, the ITB motor drive train, and the ITB rotation.
IMAGE DRUM MOTORS	Use this item to make sure that the drum motor(s) are turning. This item is also helpful to check the drum motors and drive assemblies when the back of the printer is removed, and to isolate problems in the image drums or the image drum drive assemblies.
CARTRIDGE MOTORS	Use this item to make sure that the cartridge motor(s) are turning. This item is also helpful to check the cartridge motors and drive assemblies when the back of the printer is removed, and to isolate problems in the print cartridges or the print cartridge drive assemblies.
DEVELOPER MOTORS	Use this item to make sure that the developer motor(s) are turning. This item is also helpful to check the developer motors and drive assemblies when the back of the printer is removed, and to isolate problems in the image drums or the image drum developer drive assemblies.
YMCK LASERS	Use this item to make sure that the four laser scanner assemblies are functioning correctly.
FUSER MOTOR	Use this item to test the fuser motor, or any mechanisms that are driven by the fuser motor.
MP PAPER FEED DRIVE	Use this item to test the tray 1 feed motor.
UPPER CASSETTE FEED DRIVE	Use this item to check the pick rollers for tray 2. Note M23 rotates clockwise to drive the tray 2 mechanism.
LOWER CASSETTE FEED DRIVE	Use this item to check the pick rollers for tray 3. Note M23 rotates counter clockwise to drive the tray 3 mechanism.
PREREGISTRATION	Use this item to test the registration motor (M11) and the associated clutch (CL1) Note This clutch can also be tested with the MP PAPER FEED MOTOR test.
REGISTRATION	Use this item to test the registration motor (M11) and the associated clutch (CL2 is ON for this test, but OFF in the MP PAPER FEED MOTOR test).
FACE UP SOLENOID	Use this item to test the face-up solenoid (SL2) for correct functionality.
REPEAT	Use this item to repeat a test continuously.

Service menu

The service menu printer commands should be used only by authorized service personnel. The service menu can only be opened by using the PIN code 04950003. While in the service menu, service technicians can perform the following actions:

- clear the event log
- verify and set the page counts and serial number (these are displayed on the configuration page)
- change the maintenance intervals
- set the cold reset media size

If a stapler/stacker is installed:

- calibrate the staple position
- review and edit the serial number of the output device
- review and edit the page count of the output device

Table 36. Service menu

Item	Explanation
CLEAR EVENT LOG	Clear the event log after maintenance or repairs are accomplished.
TOTAL MONO PAGES	Set the total monochrome page count if the formatter is replaced.
TOTAL COLOR PAGES	Set the total color page count if the formatter is replaced.
REFURBISH PAGE COUNT	Set to retain the page count of a refurbished printer. This allows the regular page count to be set to zero after the printer is refurbished. The refurbished page count number is zero for new printers.
CLEANING KIT COUNT	Set the total cleaning kit page count if the formatter is replaced.
TRANSFER KIT COUNT	Set the total transfer kit page count if the formatter is replaced.
FUSER KIT COUNT	Set the total fuser kit page count if the formatter is replaced.
SERIAL NUMBER	Reset the printer serial number if the formatter is replaced.
SERVICE ID	Establishes the first power-on date for warranty determination.
COLD RESET PAPER	Sets the printer default media size to A4 or letter.
STAPLER/STACKER	Perform a staple position calibration (if the stapler/stacker is attached).

Service ID

This item allows the date that the printer was first used to be shown through the control panel, eliminating the need for customers to keep paper receipts for proof of warranty. Because the printer does not have an internal clock, the service ID date's availability is dependent on the printer being connected to a source that can provide the date, such as the installer, the driver, or the embedded Web server. In cases where the printer is not connected to a date source, the service ID will not be available, and the control panel will display 000000.

Restoring the Service ID

If you replace the formatter, the date is lost. Use this menu item to reset the date to the original date that the printer or MFP was first used. The date format is YYDDD. Calculate the date as follows:

- 1 To calculate YY, subtract 1990 from the calendar year. For instance, if the printer or MFP was first used in 2002, calculate YY as follows: $2002 - 1990 = 12$. $YY = 12$.
- 2 To calculate DDD, use the following formula:
 $30(\text{calendar month} - 1) + \text{calendar day} = \text{DDD}$. If the calendar day is 31, use 30 instead. For instance, if the printer or MFP was first used on October 17, calculate DDD as follows:
 - a Subtract 1 from 10 (October is the tenth month of the year): $10 - 1 = 9$.
 - b Multiply 9 by 30: $9 \times 30 = 270$.
 - c Add 17 to 270: $270 + 17 = 287$. Thus, $DDD = 287$.

Converting the Service ID to an actual date

You can use the printer's Service ID number to determine whether the product is still under warranty. Convert the Service ID into the installation date as follows:

- 1 Add 1990 to YY to get the actual year that the product was installed.
- 2 Divide DDD by 30. If a remainder results, add 1 to the result. This is the month.
- 3 The remainder from the calculation in step 2 is the date.

Using the Service ID 12287 as an example, the date conversion is as follows:

- 1 $12 + 1990 = 2002$, so the year is 2002.
- 2 $287 \text{ divided by } 30 = 9 \text{ with a remainder of } 17$. Because a remainder results, add 1 to 9 to get 10, which represents October.
- 3 The remainder in step 2 is 17, so that is the date.
- 4 The complete date is 17-October-2002.

Settings and defaults

Note

Most of the settings that you send from software programs override printer defaults.

Temporary settings are the values that are set through your software program for the current print job. Temporary settings remain in effect until the current print job is complete.

Control panel defaults are the values that are set by selecting a control panel item and pressing ✓. An asterisk (*) next to the item name indicates that it is now the default. The printer retains default settings even when power is turned off.

Factory defaults are preset at the factory and are the default values for each menu item.

Configure the control panel display language

You can set the printer to show messages and print configuration pages in another supported language. The following are supported languages:

- Czech
- Danish
- Dutch
- English
- Finnish
- French
- German
- Greek
- Hungarian
- Italian
- Japanese
- Korean
- Norwegian
- Portuguese (Brazilian)
- Polish
- Russian
- Simplified Chinese
- Spanish Catillian
- Swedish
- Traditional Chinese
- Turkish

Note

You have the option to change the control panel language when the printer is turned on for the first time. If you did not change the control panel language when the printer was turned on for the first time, you can use either of the following procedures to select a new control panel language.

To configure the control panel language (using menus)

- 1 Press ✓ or **MENU** (MFP version) to open the menus.
- 2 Use ▲ or ▼ to scroll to **CONFIGURE DEVICE**, and then press ✓.
- 3 Use ▲ or ▼ to scroll to **SYSTEM SETUP**, and then press ✓.
- 4 Use ▲ or ▼ to scroll to **LANGUAGE**, and then press ✓.
- 5 Use ▲ or ▼ to scroll to the appropriate language, and then press ✓.
- 6 Press **PAUSE/RESUME** or **EXIT** (MFP version) to close the menus.

To configure the control panel language (power-on sequence)

- 1 Press and hold down ✓ or **MENU** (MFP version) while turning on the printer power.
- 2 Use ▲ or ▼ to scroll to **LANGUAGE**, and then press ✓ (LJ 9500) or touch the screen (LJ 9500mfp).

Note

For Japanese, Turkish, Czech, Russian, Hungarian, and Polish, the language selection changes the default symbol set for the specific language. For all other languages, the default symbol set is PC-8.

Configure the input trays

Note

The MFP tray 4 (2,000-sheet side-input tray) only supports letter and A4 size media. The MFP does *not* support custom media sizes.

You can configure the HP color LaserJet 9500 Series printer and 9500mfp input trays by type and size. You can load different media in each of the input trays and then request media by type or size.

Note

If you have used previous HP LaserJet printers, you might be accustomed to configuring tray 1 to first mode or cassette mode. To duplicate the settings for first mode, configure tray 1 for Size = **ANY** and Type = **ANY**. To duplicate the settings for cassette mode, set either the size or type for tray 1 to a setting other than **ANY**.

The following instructions are used to configure the trays at the printer control panel.

Configuring trays for standard size media

Setting a standard media size and type for tray 1

- 1 Press ✓ or **MENU** (MFP version) to open the menus.
- 2 Use ▲ or ▼ to scroll to **PAPER HANDLING**, and then press ✓.
- 3 Use ▲ or ▼ to scroll to **TRAY 1 SIZE**, and then press ✓.
- 4 Use ▲ or ▼ to scroll to the media size that you want, and then press ✓.
- 5 The media type is set to Plain by default. If you want to change this setting, use ▲ or ▼ to scroll to **TRAY 1 TYPE**, and then press ✓ (LJ 9500) or touch the screen (LJ 9500mfp). Use ▲ or ▼ to scroll to the media type that you want, and then press ✓.
- 6 Press **PAUSE/RESUME** or **EXIT** (MFP version) to close the menus.

Setting a standard media size and type for tray 2, tray 3, or tray 4

When you open and close tray 2, tray 3, or tray 4, the printer detects the media size for that tray, and the printer control panel prompts you to select the media type for that tray. If the printer cannot detect the media size, the printer control panel will prompt you to select a custom size and type. Follow these instructions to set the media size and type for tray 2, tray 3, or tray 4.

- 1 Open the tray.
- 2 Make sure that the media guides rest against the stack of media in the tray.
- 3 Set the custom/standard switch to Standard if both guides are set to the same Standard marking. Otherwise, set the switch to Custom and use the instructions in the following section.

Note

If the media size is marked on the tray guide, it is a standard media size. If the media size is not marked on the tray guide, see “Configuring trays for custom size media” on page 91.

- 4 Close the tray.
- 5 The printer detects the size of the media in the tray and message TRAY X [TYPE] [SIZE] appears. This message alternates with the message TO CHANGE TYPE PRESS ✓. The printer sets the media type to Plain by default. If you want to change this setting, use ▲ or ▼ to scroll to the media type that you want, and then press ✓.
- 6 Press PAUSE/RESUME or EXIT (MFP version) to close the menus.

Configuring trays for custom size media

Note

When a custom size is set for a tray, it is retained until the custom/standard switch in the tray is returned to Standard.

Setting a custom media size and type for tray 1

- 1 Press **✓** or **MENU** (MFP version) to open the menus.
- 2 Use **▲** or **▼** to scroll to **PAPER HANDLING**, and then press **✓**.
- 3 Use **▲** or **▼** to scroll to **TRAY 1 SIZE**, and then press **✓**.
- 4 Use **▲** or **▼** to scroll to **CUSTOM**, and then press **✓**.
- 5 The message **UNIT OF MEASURE =** appears, with the Inches setting selected by default. If you want to change this setting, Use **▲** or **▼** to scroll to the Millimeters setting, and then press **✓**.
- 6 The message **X DIMENSION =** appears, with 12 inches (or 306 millimeters) selected by default. Use the numeric keypad to type the X dimension measurement of your media, and then press **✓**.

Note

The X dimension is the width of the page as it feeds into the printer. See table 36 and table 37 for maximum and minimum dimension measurements.

- 7 The message **Y DIMENSION =** appears, with 18.50 inches (or 470 millimeters) selected by default. Use the numeric keypad to type the Y dimension measurement of your media, and then press **✓**.

Note

The Y dimension is the length of the page as it feeds into the printer. See table 36 and table 37 for maximum and minimum dimension measurements.

- 8 The message **TRAY 1 SIZE = [X DIMENSION] X [Y DIMENSION] [INCHES OR MILLIMETERS] SETTING SAVED** appears.
- 9 The media type is set to Plain by default. If you want to change this setting, use **▲** or **▼** to scroll to **TRAY 1 TYPE**, and then press **✓**. Use **▲** or **▼** to scroll to the media type that you want, and then press **✓**.
- 10 Press **PAUSE/RESUME** or **EXIT** (MFP version) to close the menus.

Setting a custom media size and type for tray 2, tray 3, or tray 4 (printer models only)

- 1 Open the tray.
- 2 Make sure that the media guides rest against the stack of media in the tray.
- 3 Set the custom/standard switch to Custom.

Note

If the media size is not marked on the tray guide, it is a custom media size. If the media is marked on the tray guide, see "Setting a standard media size and type for tray 2, tray 3, or tray 4" on page 90.

- 4 Close the tray.
- 5 The message **TRAY X SIZE =** appears, with the Any Custom size selected by default. Use **▲** or **▼** to scroll to the Custom setting, and then press **✓**.
- 6 The message **UNIT OF MEASURE =** appears, with the Inches setting selected by default. If you want to change this setting, use **▲** or **▼** to scroll to the Millimeters setting, and then press **✓**.
- 7 The message **X DIMENSION =** appears, with 12 inches (or 306 millimeters) selected by default. Use the numeric keypad to type X dimension measurement of your media, and then press **✓**.

Note

The X dimension is the width of the page as it feeds into the printer. See table 36 and table 37 for maximum and minimum dimension measurements.

- 8 The message `Y DIMENSION =` appears, with 18.5 inches (or 470 millimeters) selected by default. Use the numeric keypad to type the Y dimension measurement of your media, and then press **✓** (6).

Note

The Y dimension is the length of the page as it feeds into the printer. See table 36 and table 37 for maximum and minimum dimension measurements.

- 9 The message `TRAY X [X DIMENSION] X [Y DIMENSION] [INCHES OR MILLIMETERS] SIZE SPECIFIED BY USER` appears. This message alternates with the message `PRESS ✓ TO CHANGE TYPE`. The media type is set to Plain by default. If you want to change this setting, use **▲** or **▼** to scroll to the media type that you want, and then press **✓**.
- 10 Press **PAUSE/RESUME** or **EXIT** (MFP version) to close the menus.

Table 37. Maximum custom sizes

	Tray 1	Tray 2 and tray 3	Tray 4
Simplex and manual duplex	● 306 by 470 mm (12.05 by 18.5 inches)	● 297 by 432 mm (11.7 by 17 inches)	● 297 by 432 mm (11.7 by 17 inches)
Auto duplex	● 306 by 470 mm (12.05 by 18.5 inches)	● 297 by 432 mm (11.7 by 17 inches)	● 297 by 432 mm (11.7 by 17 inches)

Table 38. Minimum custom sizes

	Tray 1	Tray 2 and tray 3	Tray 4
Simplex and manual duplex	● 98 by 170 mm (3.9 by 6.7 inches)	● 148 by 210 mm (5.8 by 8.3 inches)	● 182 by 210 mm (7.2 by 8.3 inches)
Auto duplex	● 148 by 210 mm (5.8 by 8.3 inches)	● 148 by 210 mm (5.8 by 8.3 inches)	● 182 by 210 mm (7.2 by 8.3 inches)

Note

The leading edge is listed first in the dimensions (scan direction by feed direction) for maximum custom sizes and minimum custom sizes.

Printable area

The HP color LaserJet 9500 Series printer and the 9500MFP limit the printable area to 4.23 mm (0.17 inch) +/- 2 mm (0.01 inch) from the edges of the media, and also limits the maximum image size to 297 mm by 460 mm (11.7 by 18.1 inches).

Note

Margins can be manipulated within a software program to print up to 2 mm (0.01 inch) from the edge of the media. However, print quality might be negatively affected within 5 mm (0.2 inch) from the edge of the media.

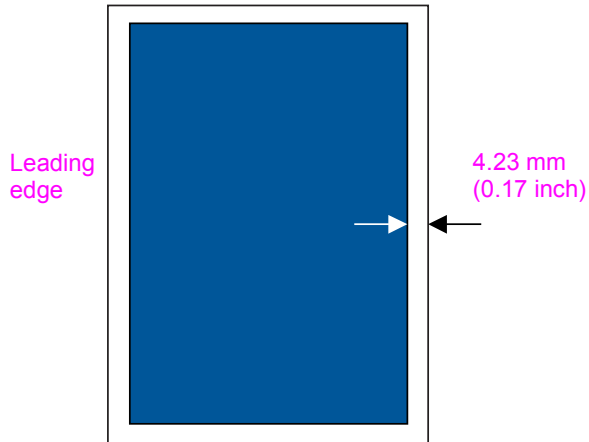

Figure 15. Printable area from edges

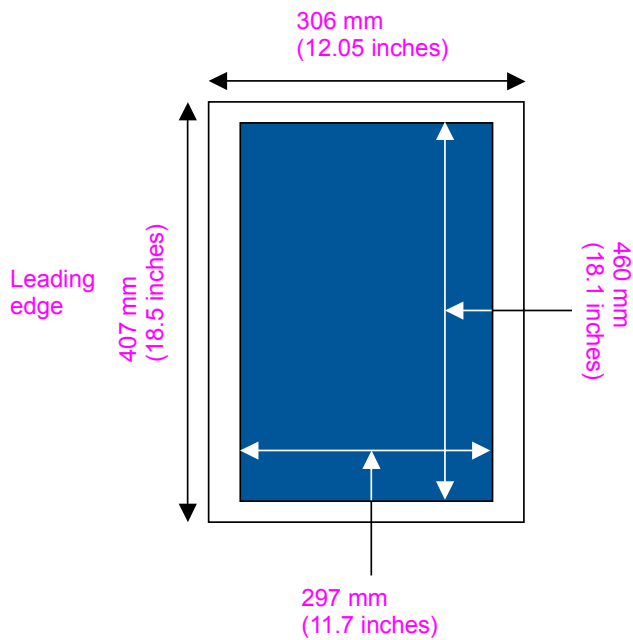

Figure 16. Maximum printable area

Boot key sequences

Note

The HP color LaserJet 9500mfp uses numeric buttons to accomplish the functions of the arrow and select buttons on the HP color LaserJet 9500 printer. On the MFP use the numeric button 3 as ▲, numeric button 5 as ↵, numeric button 6 as ✓, and numeric button 9 as ▼ on the MFP.

Hard disk reinitialization

When a hard disk is installed, it must be initialized.

Reinitialize a hard disk using the control panel

- 1 Turn the printer off.
- 2 Turn the printer on.
- 3 Press and hold **PAUSE/RESUME** (LJ 9500) or **START** (LJ 9500mfp) on the control panel during the memory count.
- 4 Hold **PAUSE/RESUME** (LJ 9500) or **START** (LJ 9500mfp) down until all three error lights illuminate steadily.
- 5 Press ↵ (the **5** button on the MFP) until `INITIALIZE DISKS` appears on the display panel.
- 6 Press ✓ (the **6** button on the MFP).
- 7 The printer begins initializing the disk (this might take a moment). The control panel displays the HP event logo and eventually displays `READY`.

Reinitialize a hard disk using PJI commands

Create the following PJI command in MS-DOS EDIT:

```
Esc E Esc%-12345X@PJI FSINIT VOLUME = "1:"
```

Copy this to the printer using the DOS command:

```
copy/b.
```

Note

For this command to take effect, the printer must be turned off and on after sending the command.

Note

Both of the above methods set the hard disk to the required state of `"VOLUME 0."`

NVRAM initialization

Note

The HP color LaserJet 9500mfp uses numeric buttons to accomplish the functions of the arrow and select buttons on the HP color LaserJet 9500 printer. On the MFP use the numeric button 3 as ▲, numeric button 5 as ↶, numeric button 6 as ✓, and numeric button 9 as ▼ on the MFP

Note

Initializing NVRAM will reset the serial number, the event log, the page counts, the calibration settings, and the EIO card. Use the Service menu to restore the serial number and page counts. You will also need to reconfigure any computers that print to this printer to recognize the printer. Initialize NVRAM only when absolutely necessary. In most situations, use a Cold reset to reset printer variables but still retain the needed values in the service menu.

Before initializing NVRAM, print a configuration page and a supplies status page to gather the following information:

- total page count and color page count
- transfer kit count
- fuser kit count
- serial number

To initialize NVRAM

- 1 Turn the printer on and watch the control panel display.
- 2 When the display begins showing the memory count, press and hold ▼ (the 9 button on the MFP) until all three lights on the control panel are lit.
- 3 Press ▲ (the 3 button on the MFP).
- 4 Press **PAUSE/RESUME** (LJ 9500) or **START** (LJ 9500mfp). The display should show `SKIP DISK LOAD`.
- 5 Press ▲ (the 3 button on the MFP) until `NVRAM INIT` is highlighted.
- 6 Press ✓ (the 6 button on the MFP). The printer will initialize NVRAM and then continue its power-on sequence.

Note

NVRAM reset can save certain key variables and restore them when the initialization is complete. A hard disk drive must be installed to perform a NVRAM reset. Items that are saved include:

- event/error log
- model number
- model name
- printer name
- printer serial number
- formatter serial number
- service ID (born-on date)
- control panel language
- default paper size
- cold reset paper size
- auto cleaning page size
- total duplex counts
- non-toner consumable counts
- engine page count
- color engine page count
- tray 1 size
- envelope feeder size
- default unit of measure for default custom paper size
- default unit of measure for each tray
- print offset registration settings
- left margin offset (for each media size)
- leading edge margin offset (default)
- usage meter date (count and charges, detail and totals)
- usage page data not related to page counts
- list of last five cartridges installed in the printer
- NVRAM values for pixel count and EPR
- consumables reorder URL

Use the following steps to perform a NVRAM restore:

- 1 Turn the printer off and replace the formatter.
- 2 Enter the NVRAM reset key sequence when the printer is turned on for the first time.
- 3 Critical values are copied from the disk to NVRAM.

The reset only works if the key sequence is entered the first time the printer is turned on after the new board is installed. If the printer is turned on without entering the key sequence, all of the values are set to what is in the NVRAM on the new board and the backup data on the disk is lost.

The hard disk is guaranteed to have the most current data backed up, so the updated data is always accurate. Also, you do not have to wait for an automatic periodic disk sync before turning the printer off to change the formatter.

Note

The NVRAM reset sequence resets all NVRAM values when a hard disk drive is not used.

Cold reset

The cold reset clears all data from the printer memory and returns all of the defaults to the factory settings.

CAUTION

Performing a cold reset resets the Jetdirect print server configuration. To avoid making changes to your network configuration, remove the HP Jetdirect print server before performing a cold reset.

Note

The HP color LaserJet 9500mfp uses numeric buttons to accomplish the functions of the arrow and select buttons on the HP color LaserJet 9500 printer. On the MFP use the numeric button 3 as ▲, numeric button 5 as ↵, numeric button 6 as ✓, and numeric button 9 as ▼ on the MFP.

Note

If possible, print a configuration page and menu map before performing a cold reset. This documents the current settings for later reference.

To perform a cold reset

- 1 Turn off the printer, and then turn the printer on again.
- 2 Press and hold ✓ (the 6 button on the MFP) during the memory count.
- 3 Continue to hold ✓ (the 6 button on the MFP) until all three control panel lights illuminate steadily, and then release ✓ (the 6 button on the MFP).
- 4 When SELECT LANGUAGE appears on the control panel, press ▼ (the 9 button on the MFP).
- 5 COLD RESET appears.
- 6 Press ✓ (the 6 button on the MFP) while COLD RESET appears on the control panel. The cold reset is complete.

To skip disk

Use the skip disk function to turn on the printer without recognizing the hard disk. This is useful for troubleshooting hard disk problems without having to remove the hard disk.

- 1 Turn off the printer, and then turn the printer on again.
- 2 Press and hold ▼ (the 9 button on the MFP) during the memory count.
- 3 Continue to hold ▼ (the 9 button on the MFP) until all three control panel lights illuminate steadily, and then release ▼ (the 9 button on the MFP).
- 4 Press ▲ (the 3 button on the MFP), and then press PAUSE/RESUME (LJ 9500) or START (LJ 9500mfp).
- 5 When SKIP DISK LOAD appears on the control panel, press ✓ (the 6 button on the MFP).
- 6 The printer starts without recognizing the hard disk.

To skip calibration

- 1 Turn off the printer, and then turn the printer on again.
- 2 Press and hold ▼ (the 9 button on the MFP) during the memory count.
- 3 Press ▲ (the 3 button on the MFP), and then press PAUSE/RESUME (LJ 9500) or START (LJ 9500mfp).
- 4 Scroll to SKIP CALIBRATION, and then press ✓ (the 6 button on the MFP).
- 5 The printer starts without calibrating.