

6

Removal and replacement

Chapter contents

Introduction	197
Removal and replacement strategy	197
General cautions during removal and replacement	197
Electrostatic discharge	198
Required tools	198
Flat flexible cable caution	199
DC controller and cable/connector damage areas	200
Potential damage areas while servicing	200
Consumables	201
Toner cartridges (print cartridges)	201
Process cartridges (image drums)	203
Waste toner bottle (toner collection bottle)	205
Transfer cleaner (cleaning blade)	206
Transfer roller	207
External covers	208
Control panel overlay	208
Control panel	209
Right upper cover	210
Left upper cover	212
Top right cover	213
Top left cover	215
Front doors	217
Intermediate transfer belt (ITB) door	220
Left back cover	224
Left lower cover	225
Right back cover	227
Back cover	228
Major assemblies	229
Process cartridge (image drum) door	229
Laser/scanner assembly	231
Printing a laser/scanner adjustment page	233
Reading a laser/scanner adjustment page	235
Adjusting the laser/scanner assemblies	237
Delivery unit	249
Delivery unit sensor	253
Vertical feed unit	254
Duplexer	258
Fuser	259
Intermediate transfer belt (ITB)	260
Density and registration sensor assembly	262
Right back fan	265
Right front fan	266
Secondary transfer assembly (T2)	267

Pickup unit	272
Temperature and humidity sensor	280
High-voltage power supply	281
Low-voltage power supply	282
Registration assembly	283
Delivery fan	290
Fuser fan	291
P-crg (image drum) drive assembly	292
T-crg (print cartridge) drive assembly	296
Fuser motor	298
Fuser drive assembly	299
DC controller	300
Formatter PCB	302
Formatter cage	304
High-voltage contact	306
Post charger power supply	307
Tray 1 pickup roller	309
Tray 1 separation pad	310
Left door switch	311
Right door switch (front and right side doors)	312
ITB sensor	313
Upper left door sensor	314
Fuser front paper sensor	315
Fuser sensor PCA	316
2,000-sheet tray 4 for the HP LaserJet 9500hdn printer	317
Left side cover	318
Right side cover	319
Back covers	320
Tray 4	321
Rollers (pickup, feed, and separation)	322
Registration assembly	323
Drive motor	324
Drive assembly	324
Controller board	325
Paper-size detection switch PCB	326
Power supply	327
Pickup assembly	328
Paper connecting unit	329

Introduction

WARNING!

When the power is turned off by using the power switch on the HP LaserJet 9500mfp, the AC voltage to the Scanner/ADF unit is still present. To avoid injury, you must unplug the power cord from the wall receptacle before servicing the MFP.

Removal and replacement strategy

This chapter documents the removal and replacement of field replaceable units (FRUs) for the printer models and for the print engine system of the MFP.

Note

For removal and replacement instructions for the scanner/ADF portion of the MFP, see the *HP Scanner/ADF Service Manual for the HP LaserJet 9000mfp/9000Lmfp/9040mfp/9050mfp/9500mfp* (PN C8549-90955). For removal and replacement instructions for the 2,000-sheet side feeder, see the *2,000-sheet Side-input Tray Service Manual* (PN Q1891-90901). For removal and replacement instructions for the finishing device, see the *Paper Handling Accessories Service Addendum* (PN Q5693-90002).

A complete service manual bundle is available by ordering the *Service Bundle for HP Color LaserJet 9500/9500mfp* (PN C8549-99001). The service bundle includes the manuals listed above, this print engine manual, and the *Paper Handling Accessories Service Addendum* (PN C85693-90002).

Throughout this document, the term “printer” is used to refer to both the HP LaserJet 9500 Series printer models *and* the HP LaserJet 9500mfp. Make sure to read the headings and text carefully to understand the context of the term.

Replace parts in the reverse order of their removal. Directions for difficult or critical replacement procedures are included.

General cautions during removal and replacement

Before removing or replacing assemblies and parts:

- make sure that the printer is turned off
- disconnect all cables and cords
- use caution, the printer can have sharp sheet-metal edges

If the printer has been running continuously prior to servicing, turn the power off but allow the printer to remain plugged in with the cooling fans running for at least 10 minutes before unplugging the power cord.

CAUTION

Exercise caution when removing and replacing the ITB. Place it on a flat, clean surface because the belt is exposed on the bottom of the assembly. Make sure that you do not disturb the toner in the toner collection bottle. Toner and static charges might dust and block the sensor windows.

Note

Always remove the image drums before removing or replacing assemblies and parts that are near the drums. **IMPORTANT:** Put the image drums in the original protective plastic sleeves, or, if the sleeves are not available, place the image drums right-side up on a hard, flat, clean surface. Do not place the image drums on carpet or a dusty surface because contaminants (such as dust and fibers) can stick to the OPC and diminish print quality. Light can damage the image drums.

Note

Note the lengths, diameters, and locations of screws. Be sure to return each screw to its original location during reassembly. Incorrectly routed or loose wire harnesses can interfere with other internal components and can become damaged or broken. Frayed or pinched harness wires can be difficult to locate. When replacing wire harnesses, always use the provided wire loops, lance points, or wire-harness guides.

Electrostatic discharge

CAUTION



The printer contains parts that are sensitive to electrostatic discharge (ESD). Always service the printer at an ESD-protected workstation, or use an ESD mat.

Watch for the ESD symbol (shown at left) to identify the parts that are sensitive to ESD. Protect these parts by using an ESD wrist strap and protective ESD pouches.

Required tools

The following tools are needed to service the printer and the finishing device:

- #2 Phillips screwdriver with magnetic tip (one short-reach and one long-reach)
- Small flatblade screwdriver; Small needle-nose pliers
- ESD mat and wrist strap; Penlight

CAUTION

A PoziDriv screwdriver will damage screw heads on the printer. Be sure to use a #2 Phillips screwdriver. If you have an electric or multi-speed screwdriver, use a torque limiter or set the clutch to apply low torque.

Table 50. Hardware table

Example	Type and uses
	<ul style="list-style-type: none"> ● Long aluminum finish (M 3 x 8) <ul style="list-style-type: none"> • Plastic to sheet metal • Long reach sheet metal (P-cartridge motor assembly) ● Short brass finish (M 3 x 6) <ul style="list-style-type: none"> • Sheet metal to sheet metal ● Short black finish (M 3 x 8) <ul style="list-style-type: none"> • Laser/scanner assemblies ● Self-threading brass finish (M4) <ul style="list-style-type: none"> • Sheet metal to plastic

Table 51. Common torque values

Material	HP recommended torque value
Plastic to metal	5.5 lb-inch
Metal to metal	10 lb-inch
PCBA	5.5 lb-inch
Plastic to plastic	5.5 lb-inch

Flat flexible cable caution

Flat flexible cables (FFCs) can break easily because you must unlatch them. FFCs are easy to crease, cut, bend, or rip.

The following are steps for removing the FFCs:

- 1 Locate the FFC connection.
- 2 Use your finger to open the cover.
- 3 Gently pull the cable.
- 4 Remove the cable.

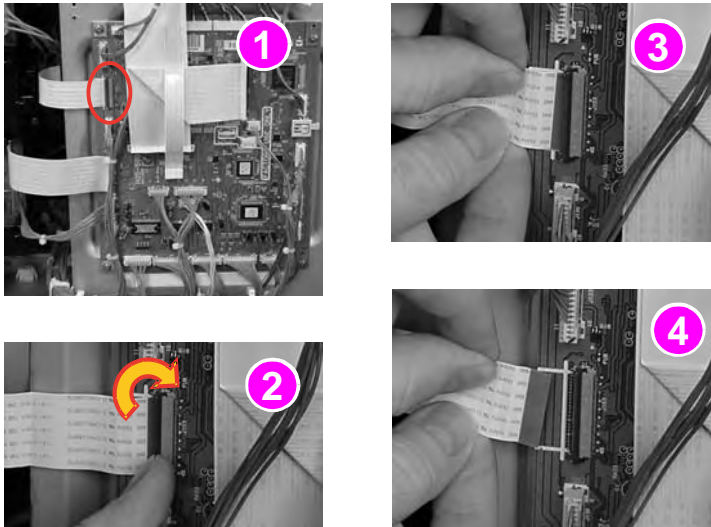

Figure 72. Remove the FFC

To reinstall

Make sure that you align the FFC correctly and that the cable remains completely inserted and correctly registered when you are fastening the cover or the lock. A partially seated FFC can cause irreparable damage to the cartridge e-labels and can cause motor stall errors.

DC controller and cable/connector damage areas

Note

When replacing the DC controller, connect and check each of the 25 connectors by pressing each one of them.

CAUTION

Do not open the FFC covers until you know exactly how to unlatch the connector. The DC controller can be permanently damaged if the brown retainer is broken while lifting the white retainer.

- A. This type of connector can break easily because you must unlatch them.
- B. Lift-and-pull removal makes this connector easy to break. Also, it is easy to damage the cable when you lift the white retainer.
- C. This type of connector is easier to remove than the other two types. Simply pull the cable out or push it in.

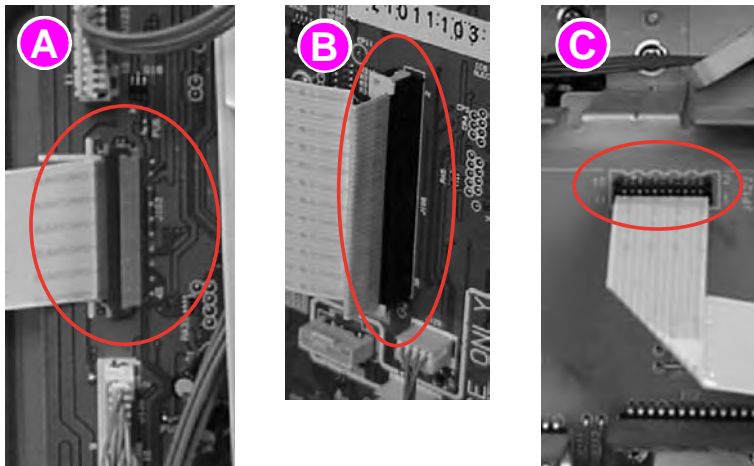

Figure 73. DC controller and cable/connector damage areas

CAUTION

Stabilize the DC controller board to counter resistance while pulling on the copper wire connectors. Grasp the entire harness and pull on the wires perpendicular and evenly to avoid tearing out a single wire.

Potential damage areas while servicing

The following are potential areas for damage while the printer is being serviced:

- the print cartridge bottoms (remove the print cartridges when servicing areas near them)
- the white plastic tab on the P-cartridge drive assembly (drives the ITB)
- the ITB
- the toner collection bottle
- the tower on the T-drive assembly
- the P-cartridge drive assembly

Consumables

Toner cartridges (print cartridges)

- 1 Open the front doors.



Figure 74. Gain access to the toner cartridges

- 2 Rotate the blue lever clockwise.



Figure 75. Rotate the toner cartridge lever

- 3 Pull the toner cartridge out.



Figure 76. Remove the toner cartridge

Note If necessary, repeat these steps for the other three toner cartridges.

Process cartridges (image drums)

Note

Image drums must be placed face-down on a flat, clean surface.

- 1 Rotate the green lever clockwise.

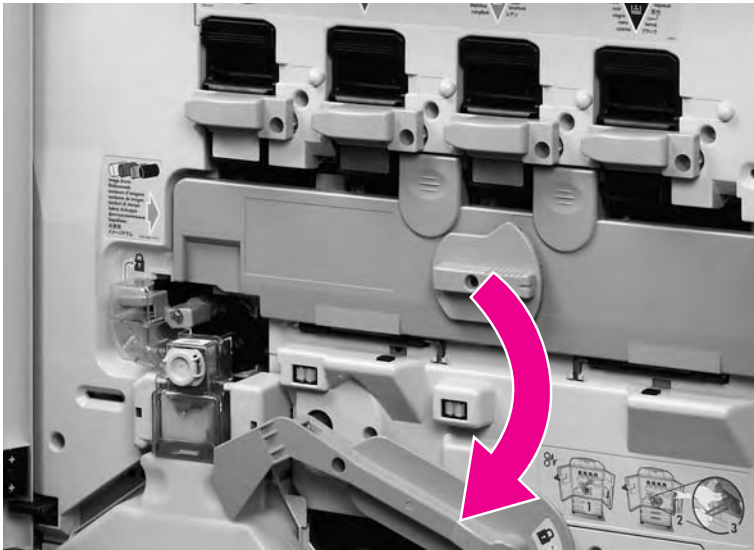

Figure 77. Gain access to the process cartridge door

- 2 Rotate the blue dial counterclockwise.

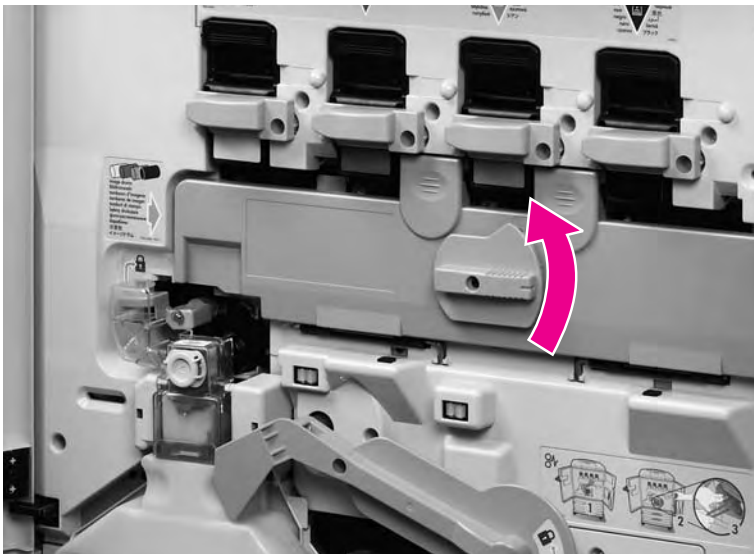

Figure 78. Rotate the process cartridge door dial

- 3 Open the process cartridge door.

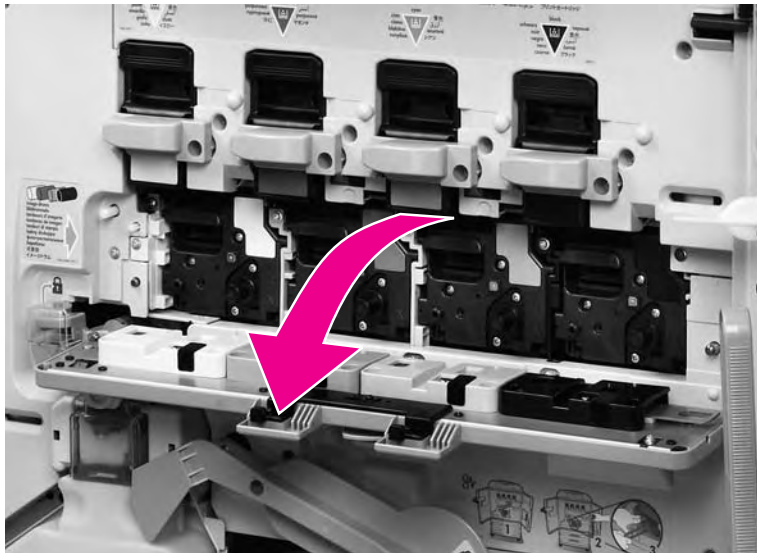

Figure 79. Open the process cartridge door

- 4 Pull the process cartridge out.

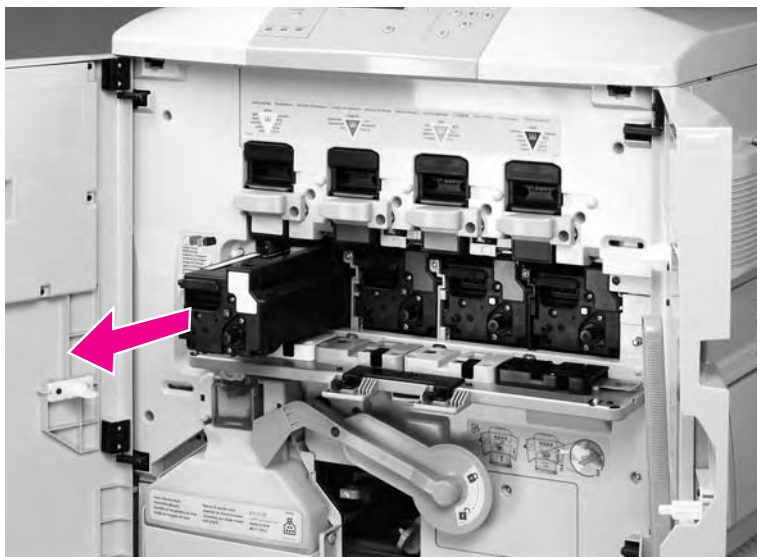

Figure 80. Remove the process cartridges

Note If necessary, repeat these steps for the other three process cartridges.

Waste toner bottle (toner collection bottle)

- 1 Hold the top of the waste toner bottle and pull it out.



Figure 81. Remove the waste toner bottle

Transfer cleaner (cleaning blade)

- 1 Rotate the blue lever down.

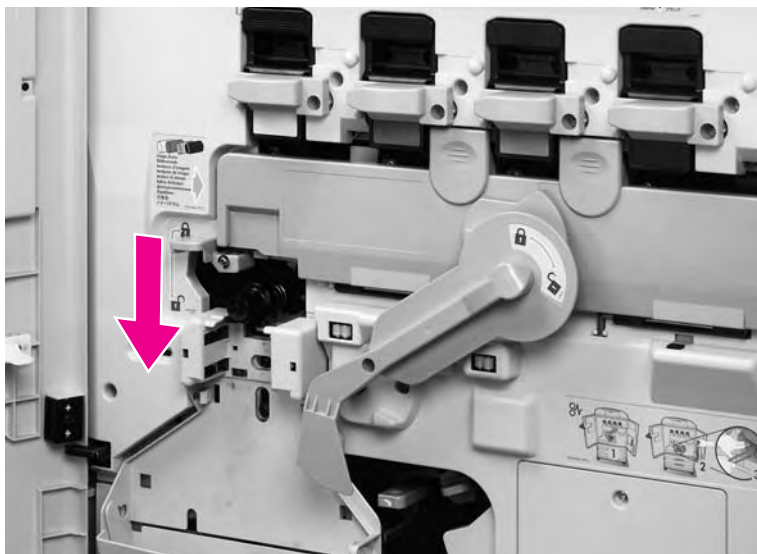

Figure 82. Unlock the transfer cleaner

- 2 Pull out the transfer cleaner.



Figure 83. Remove the transfer cleaner

Transfer roller

Note

Do not touch the surface of the transfer roller.

- 1 Rotate the green lever clockwise.

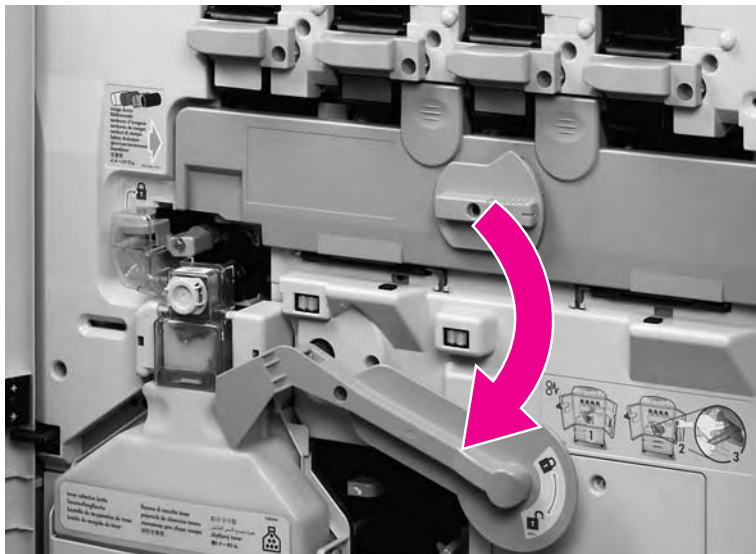

Figure 84. Disengage the ITB to release the transfer roller

- 2 Grasp the blue tab and pull the transfer roller out.

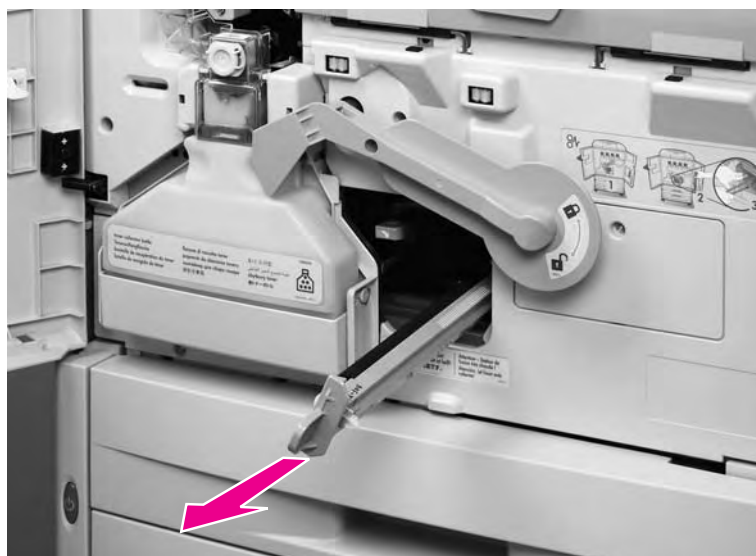

Figure 85. Remove the transfer roller

External covers

Control panel overlay

- 1 Insert a small screwdriver and remove the control panel overlay.



Figure 86. Remove the control panel overlay

Control panel

- 1 Open the front doors.
- 2 Release two tabs on the underside of the control panel by pulling them toward the front of the printer.



Figure 87. Release the control panel

- 3 Lift the control panel straight up.
- 4 Unplug the cable connector (callout 1) on the underside of the control panel.

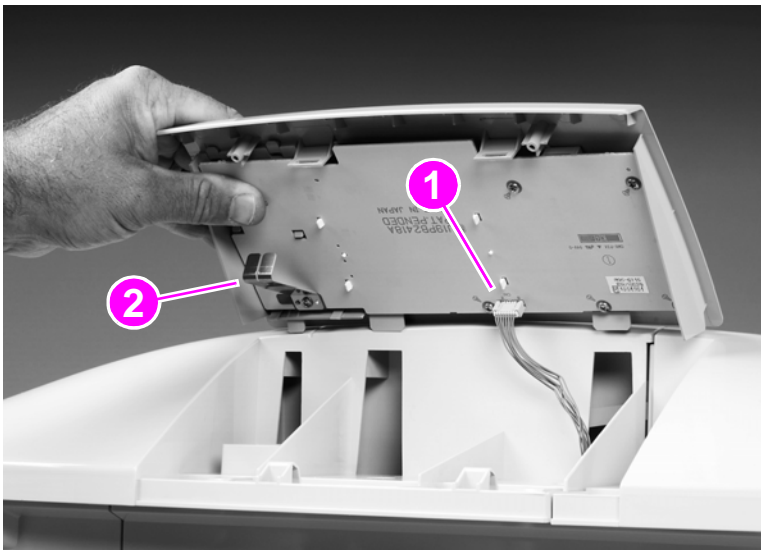

Figure 88. Remove the control panel

- 5 Remove the control panel from the printer.

To reinstall

Make sure that you do not bend the grounding strip (callout 2) on the control panel.

Right upper cover

- 1 Remove the ozone filter (callout 1).
- 2 Open the right intermediate transfer belt (ITB) door.

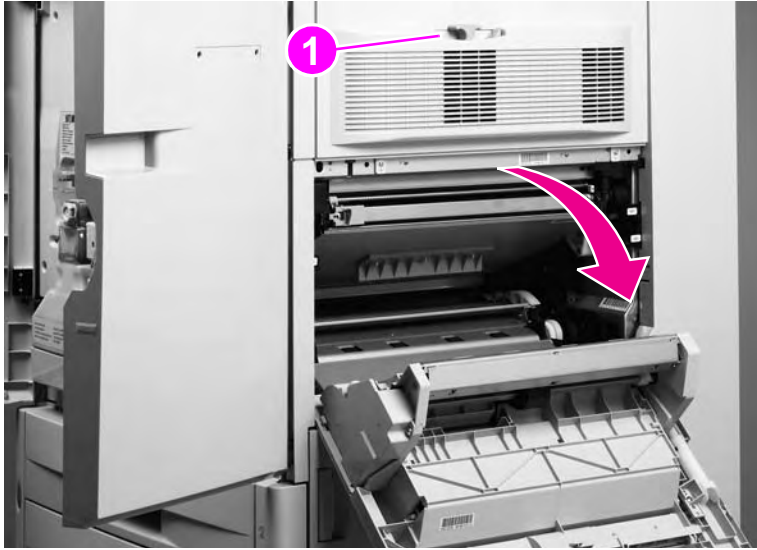

Figure 89. Gain access to the right upper cover mounting screws

- 3 Remove two screws (callout 2).

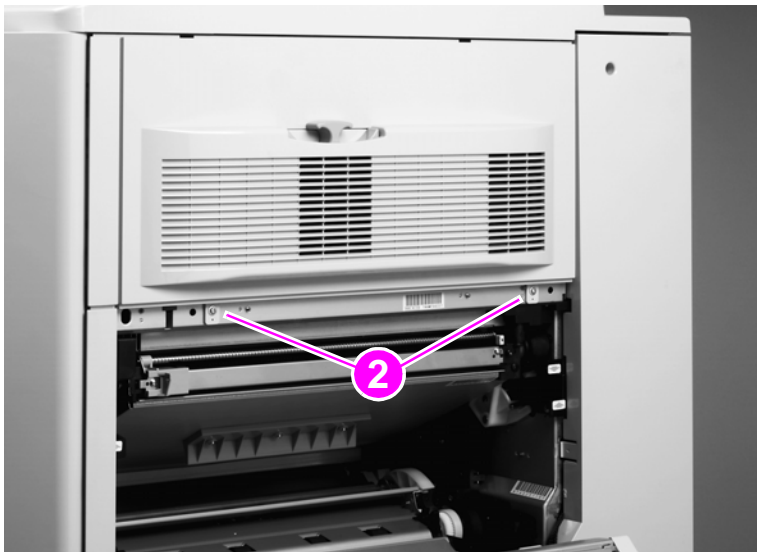

Figure 90. Remove the right upper cover mounting screws

- 4 Pull out the bottom of the right upper cover and remove it.

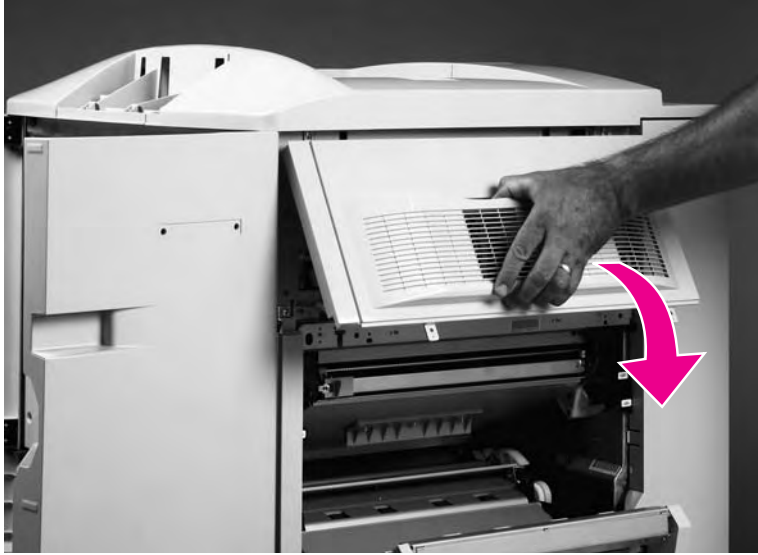

Figure 91. Remove the right upper cover

Left upper cover

- 1 Open the left upper door.

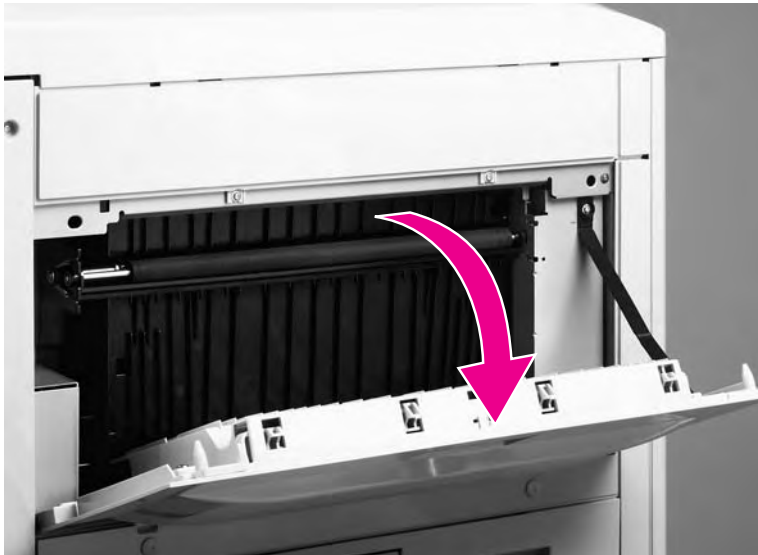

Figure 92. Gain access the left upper cover mounting screws

- 2 Remove two screws (callout 1).

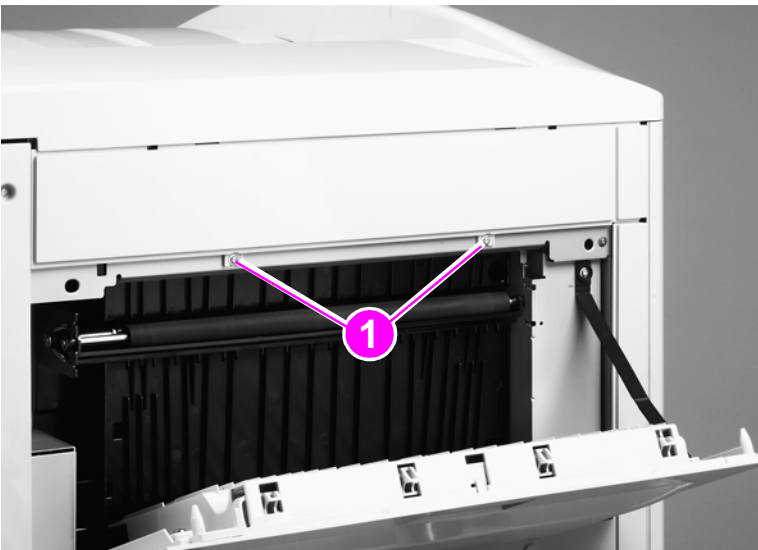

Figure 93. Remove the left upper cover mounting screws

- 3 Remove the left upper cover.

Top right cover

- 1 Remove the following assemblies:
 - Control panel. See page 208.
 - Right upper cover. See page 210.
- 2 Open the front doors.
- 3 Remove two screws (callout 1).

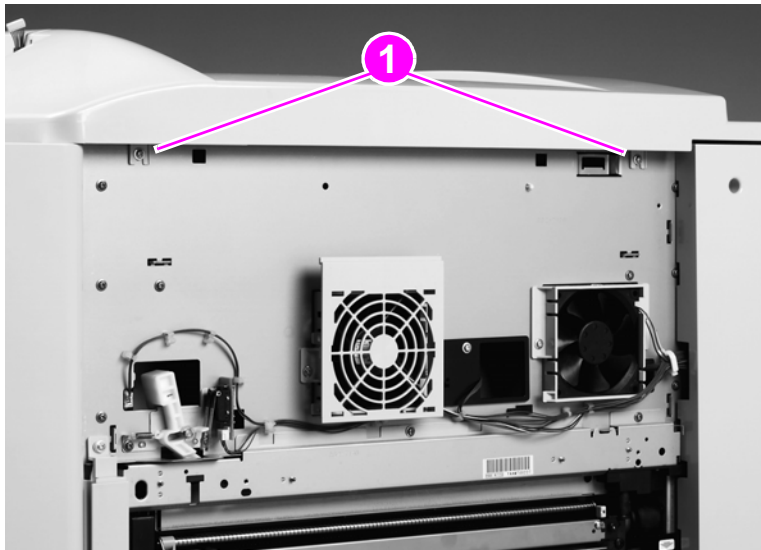

Figure 94. Remove the top right cover mounting screws

- 4 Remove the top right cover.

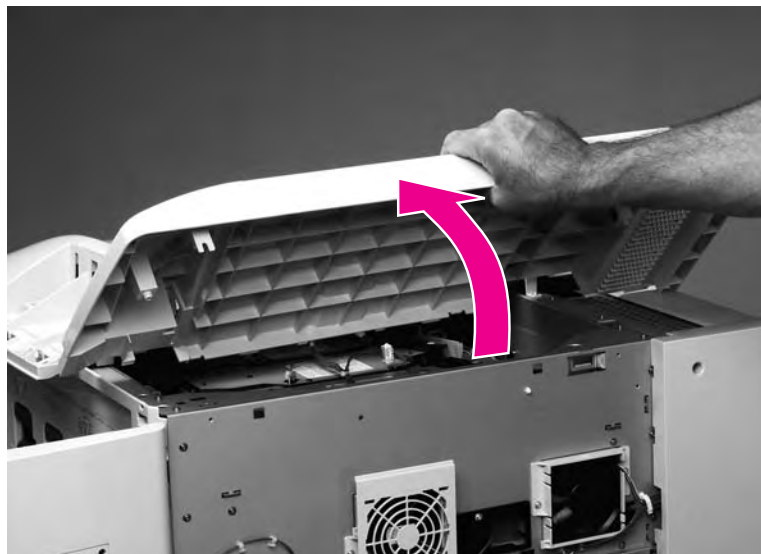

Figure 95. Remove the top right cover

To reinstall

Make sure that the tabs and locator pins are lined up correctly (callout 2).

Hint

Loosen the front middle screw (callout 3) so the tabs are easier to insert.

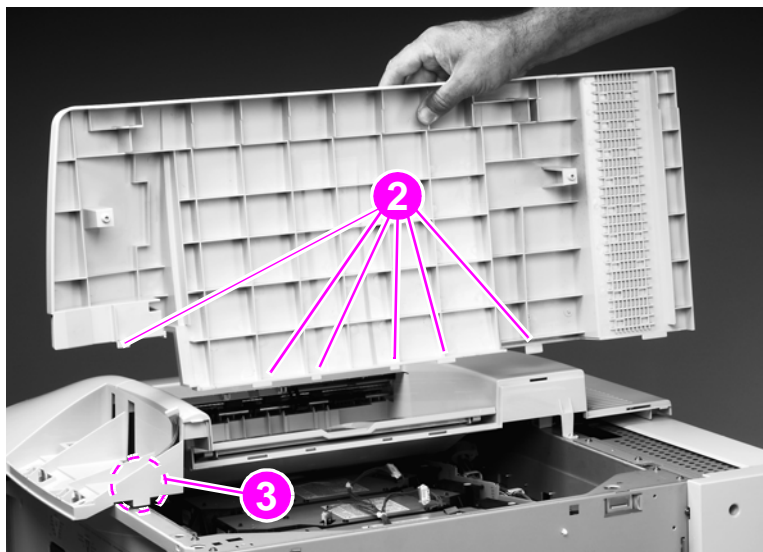

Figure 96. Reinstalling the top right cover

Top left cover

- 1 Remove the following covers:
 - Left upper cover. See page 212.
 - Top right cover. See page 213.
- 2 Remove two screws (callout 1).

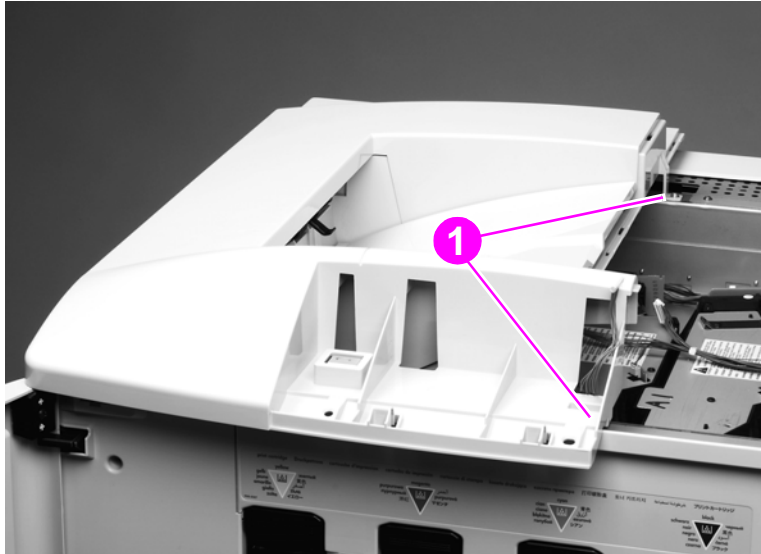

Figure 97. Remove the top left cover mounting screws (1 of 2)

- 3 Remove two screws (callout 2).

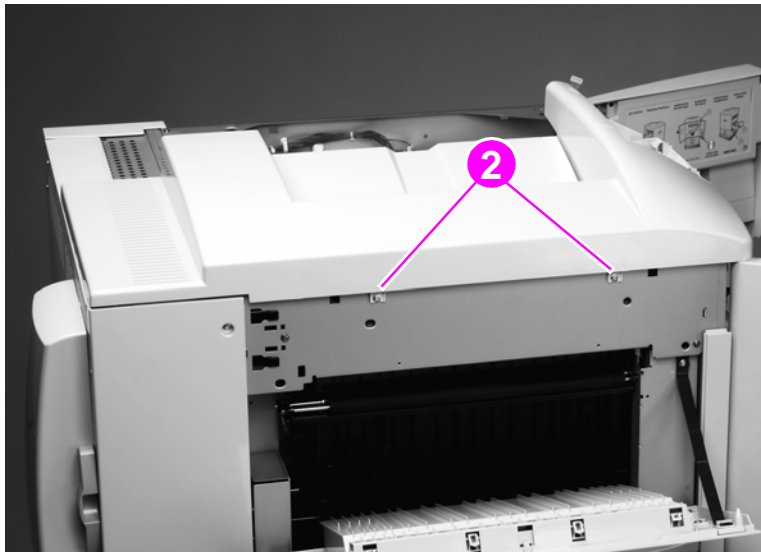

Figure 98. Remove the top left cover mounting screws (2 of 2)

- Lift up the top left cover and remove it to your right.

CAUTION

Be careful not to damage the face-down output tray-full sensor and the control panel cable.

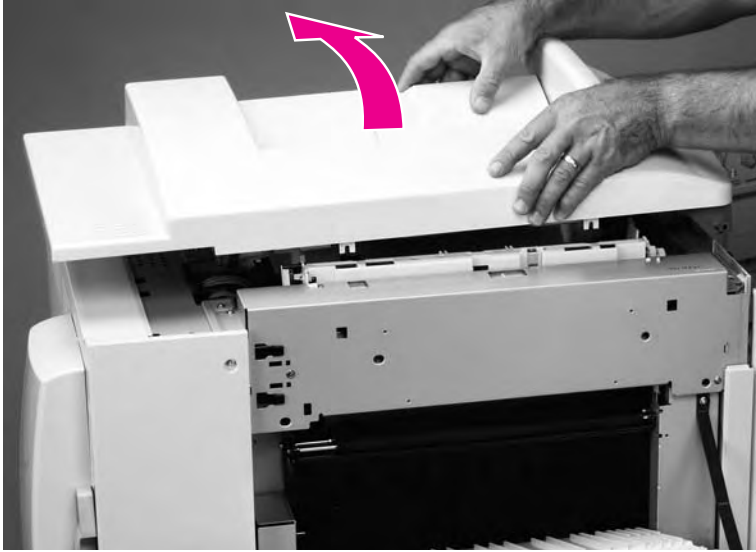

Figure 99. Remove the top left cover

To reinstall

Make sure that the spring is correctly positioned in the pedestal clips, and that the top of the spring is correctly positioned on the plastic cross hairs.

CAUTION

Make sure that the output tray-full sensor (callout 3) is above the output bin, and be careful not to damage the control panel cable.

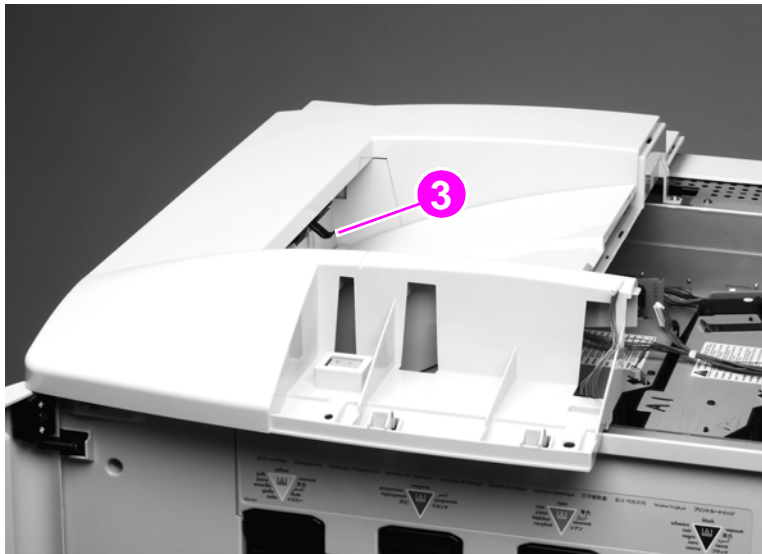

Figure 100. Reinstall the top left cover

Front doors

- 1 Remove the following covers:
 - Right top cover. See page 213.
 - Left top cover. See page 215.
- 2 Lift up and remove the front door.

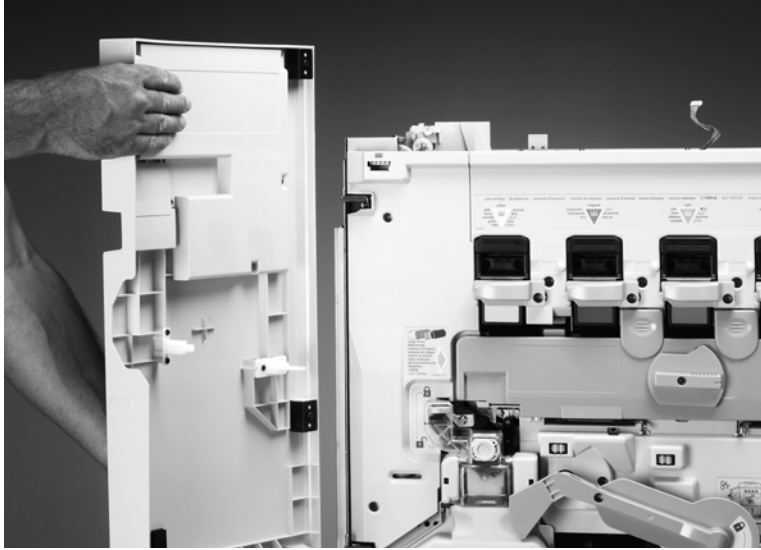

Figure 101. Remove the front doors

Fuser door

- 1 Open the fuser access door.

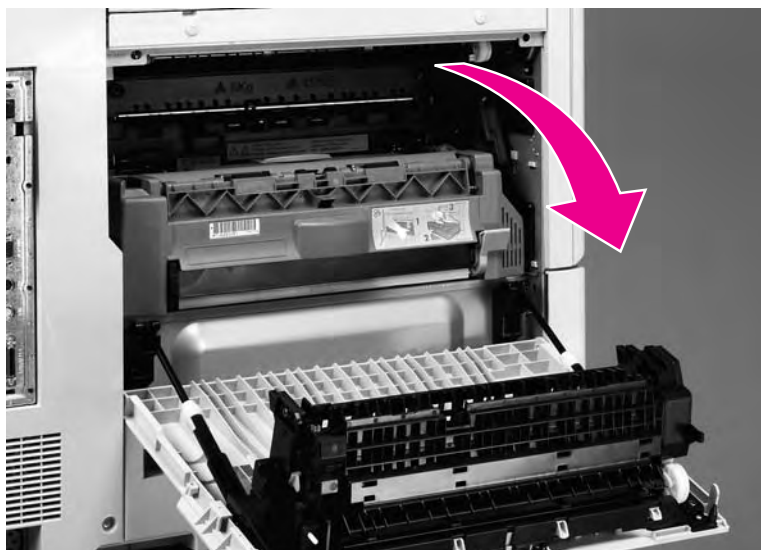

Figure 102. Gain access to the fuser

- 2 Push the spring-loaded door rod down and to the back to remove it from the bracket (callout 1).

Hint

Hold the door with one hand while holding the rod with your other hand.

CAUTION

The rods are under tension and the pins in the rods are not secure.

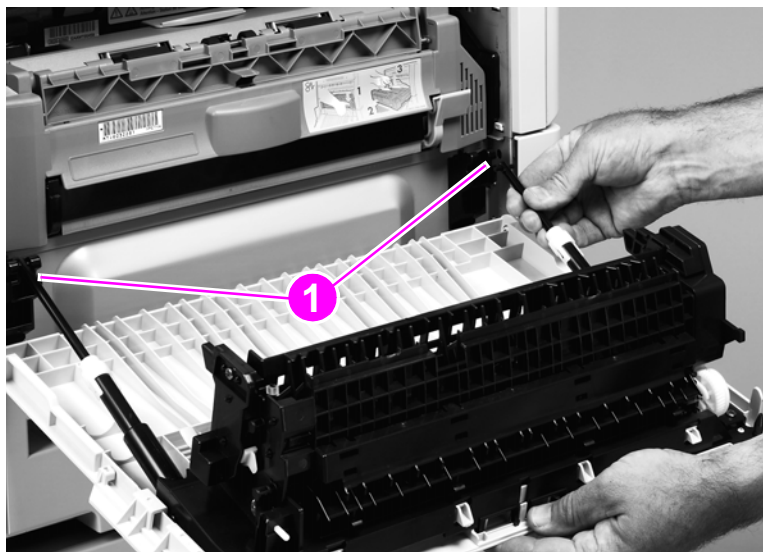

Figure 103. Release the fuser door pistons

- 3 Align the flat side of the pivot hole on the left side of the door with the flat sides of the pivot pin.

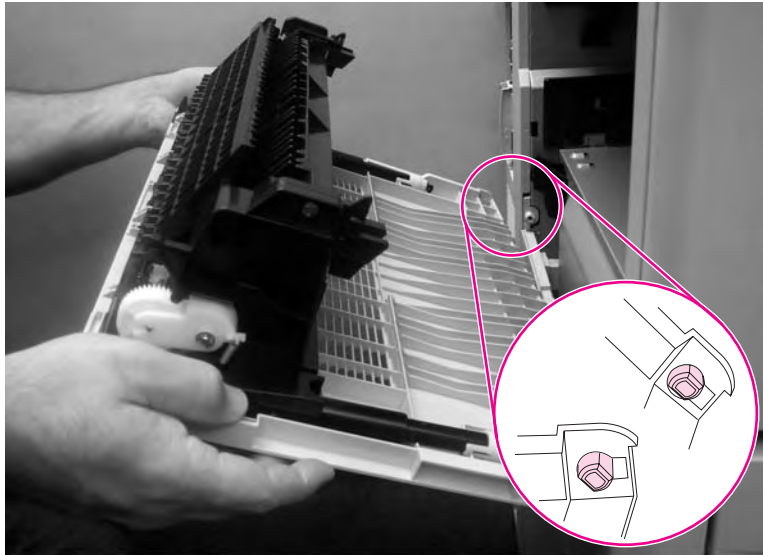

Figure 104. Remove the fuser door

- 4 Rotate the door away from the printer.
- 5 Remove the fuser door.

Intermediate transfer belt (ITB) door

- 1 Remove the right back cover. See page 227.
- 2 Open the right lower door assembly, and remove one screw (callout 1) on the retaining strap of the door assembly.

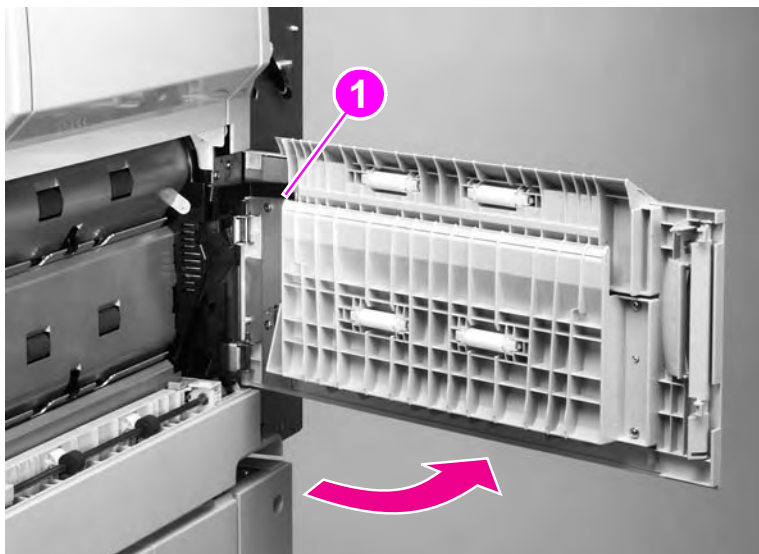

Figure 105. Release the right lower door

- 3 Remove the right lower door assembly.

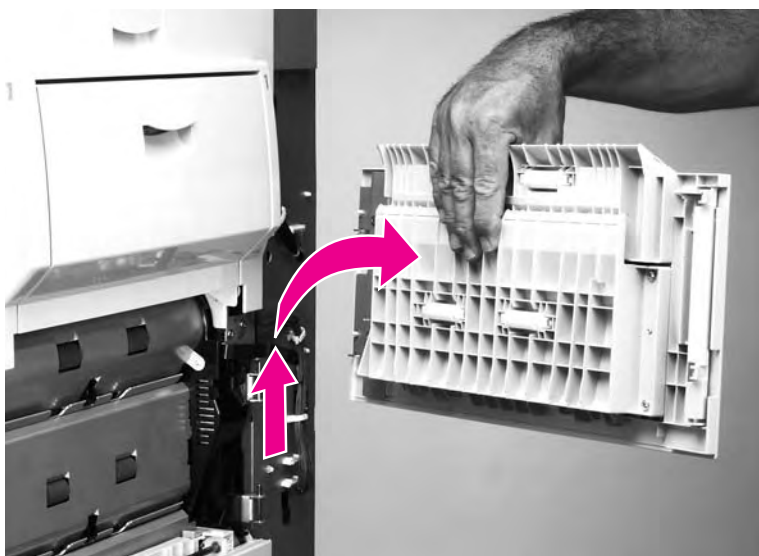

Figure 106. Remove the right lower door assembly

- 4 Open the right upper door (ITB access door).



Figure 107. Open the ITB door

- 5 Remove seven screws (callout 2).
- 6 Remove the shield (callout 3).

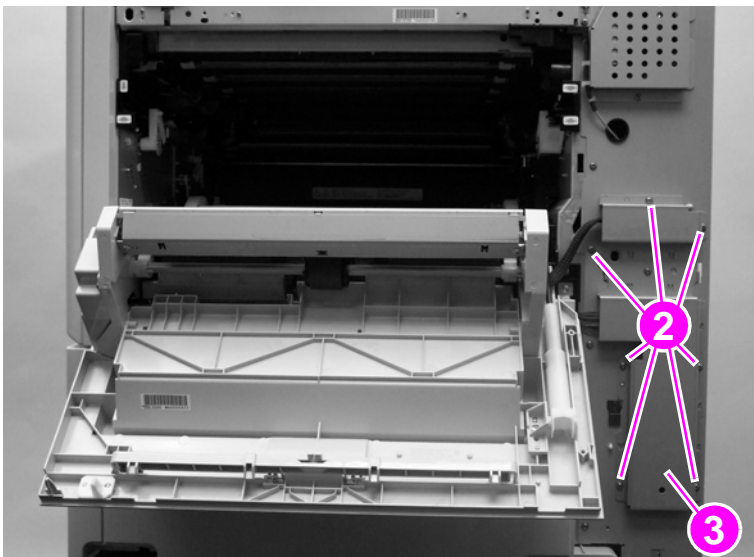

Figure 108. Remove the wire harness shield

- 7 Disconnect one cable connector (callout 4), and unclip one wire harness (callout 5).
- 8 Push the spring-loaded door rod down and to the back to remove it from the bracket (callout 6).

Hint Hold the door with your left hand while holding the rod with your right hand.

CAUTION The rod is under tension and the pins in the rod are not secure.

Note Do not remove the pin from the rod.

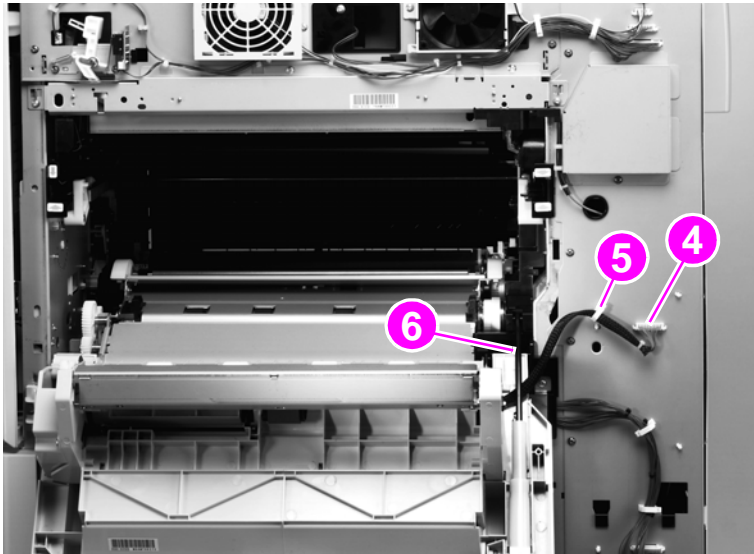

Figure 109. Disconnect the ITB door wire harness

- 9 Close the right upper door.



Figure 110. Gain access to the ITB door mounting screws

10 Remove three screws (callout 7).

11 Open the right upper door slightly and remove the bracket (callout 8).

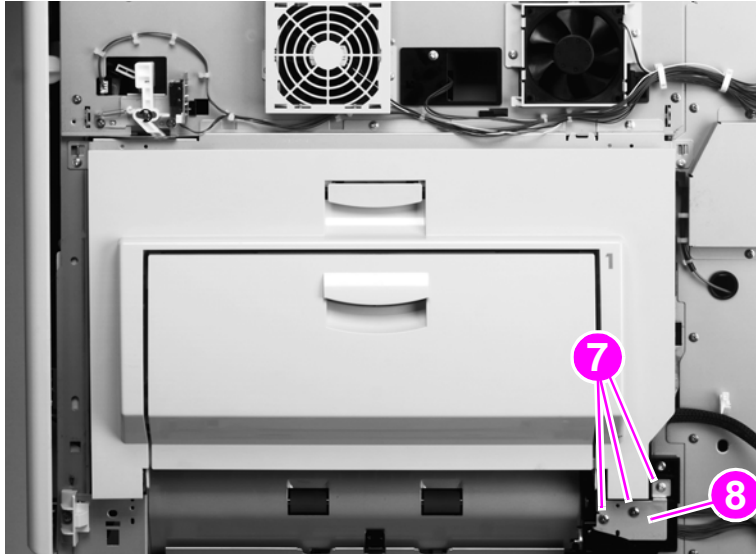

Figure 111. Remove the ITB door mounting screws

12 Shift the ITB door toward the back of the printer and remove it.

Left back cover

- 1 Remove 8 screws (callout 1).

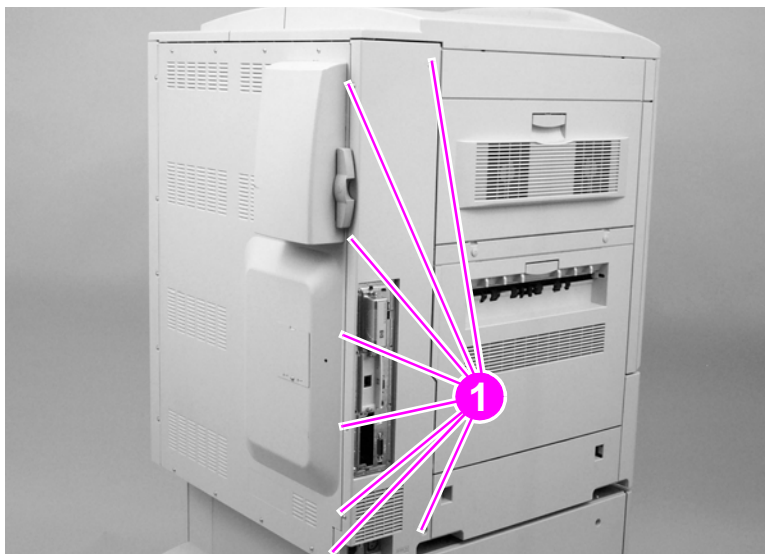

Figure 112. Remove the left back cover

- 2 Remove the left back cover.

Left lower cover

- 1 Remove the following assemblies:
 - Fuser door. See page 218.
 - Left back cover. See page 224.
- 2 Remove four screws (callout 1).

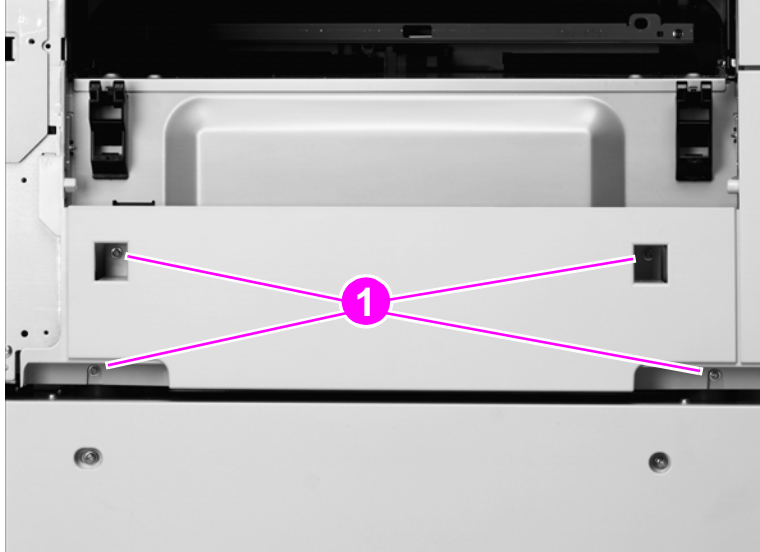

Figure 113. Remove the left lower cover mounting screws

- 3 Remove tray 2 and tray 3.
- 4 Remove one screw (callout 2), and remove the front left cover (callout 3).

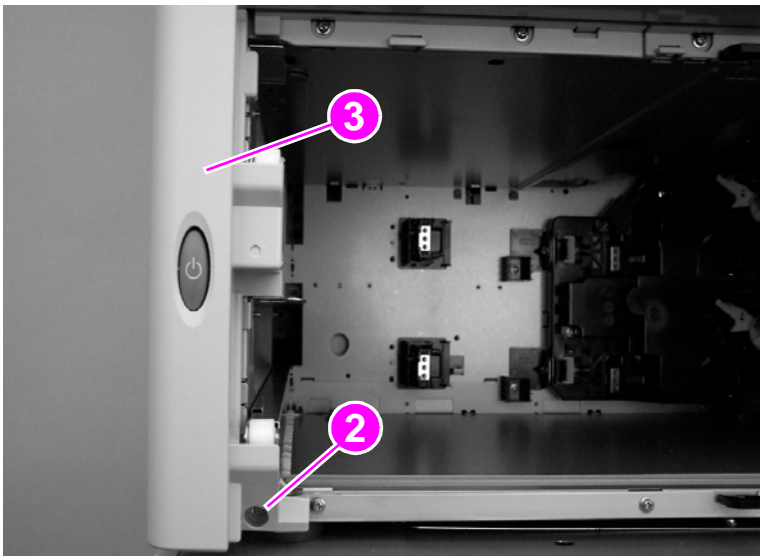

Figure 114. Remove the front left cover

- 5 Depress two tabs (callout 4).

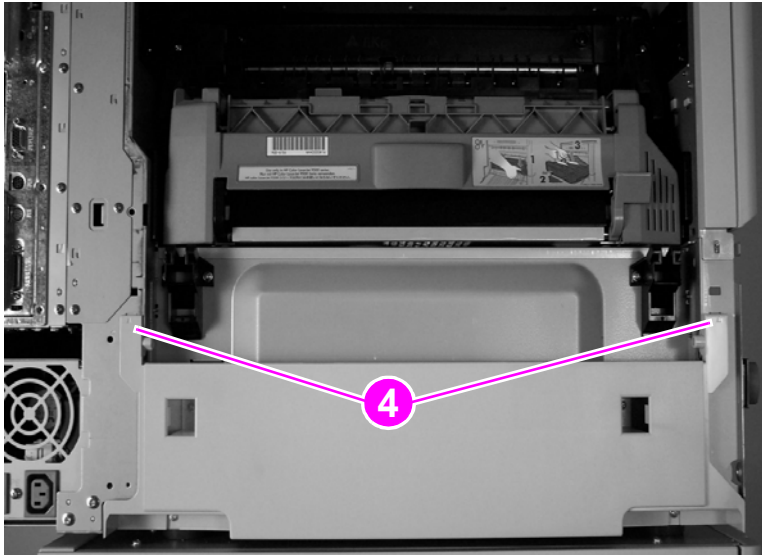

Figure 115. Release the left lower cover tabs

- 6 Remove the left lower cover.

Right back cover

- 1 Remove seven screws (callout 1), and depress the tab (callout 2) near the ITB access door.

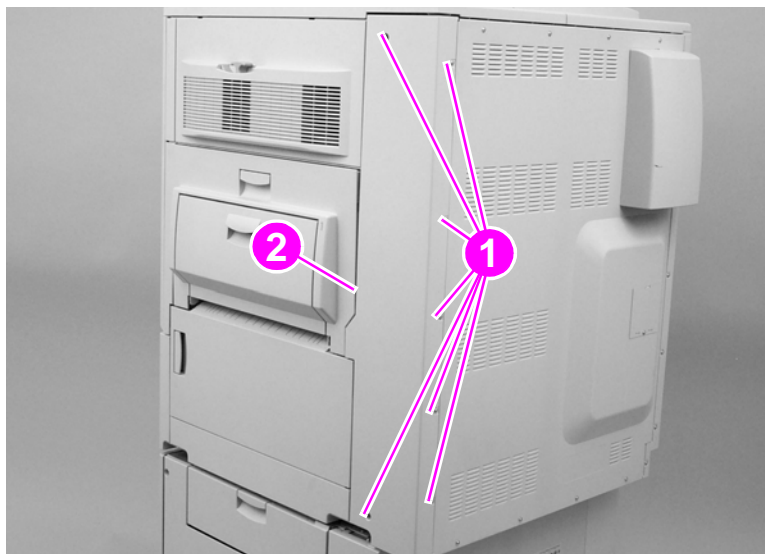

Figure 116. Remove the right back cover

- 2 Remove the right back cover.

Back cover

- 1 Remove following covers:
 - Left back cover. See page 224.
 - Right back cover. See page 227.
- 2 Remove one filter (callout 1), and remove eight screws (callout 2).

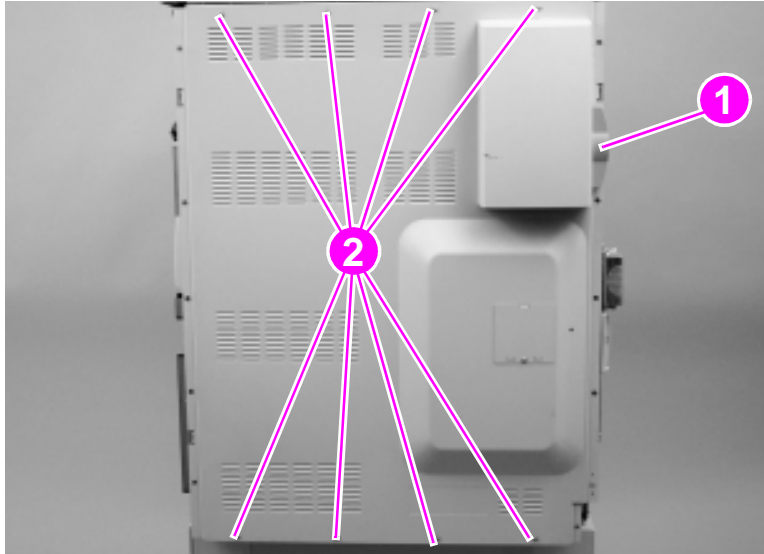

Figure 117. Remove the back cover

- 3 Remove the back cover.

Major assemblies

Process cartridge (image drum) door

- 1 Remove the four process cartridges. See page 203.
- 2 Rotate the green lever down.
- 3 Unclip the drum door hinge pins (callout 1) with a screwdriver.

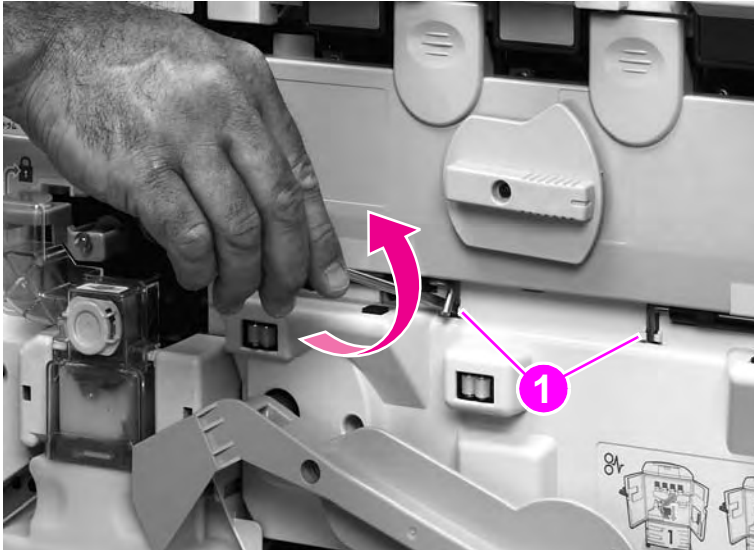

Figure 118. Unclip the process cartridge door hinge pins

- 4 Unlock the process cartridge door.

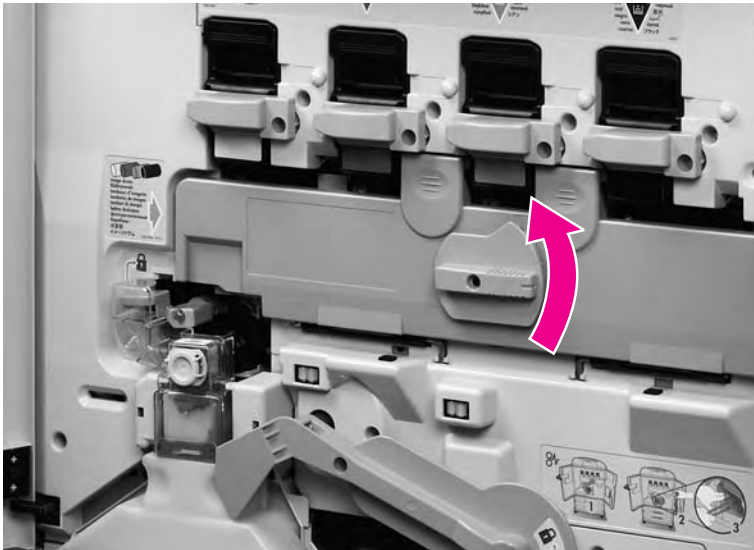

Figure 119. Unlock the process cartridge door

- 5 Open the process cartridge door halfway.

- 6 Remove the hinge pins.

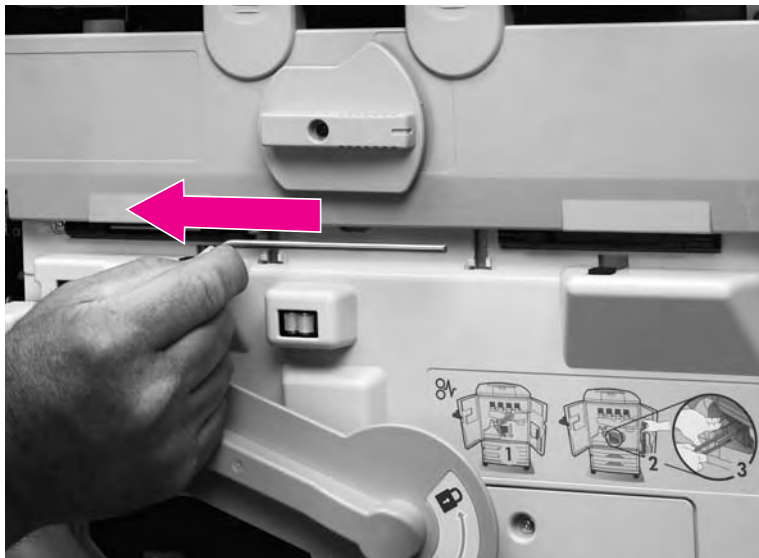

Figure 120. Remove the process cartridge door hinge pins

- 7 Remove the process cartridge door.



Figure 121. Remove the process cartridge door

Note

After replacing the process cartridge door, print a laser alignment test page and, if necessary, perform a laser alignment procedure. See page 233.

Laser/scanner assembly

- 1 Remove the following covers:
 - Top right cover. See page 213.
 - Top left cover. See page 215.
 - MFP only: remove the scanner/ADF assembly (see the *Scanner Service Manual for the HP LaserJet 9000/9000Lmfp/9040mfp/9050mfp/9500mfp*)
- 2 Disconnect three connectors (callout 1), and remove four black screws (callout 2).

Note

Depending on which laser/scanner assembly needs to be removed, disconnect the appropriate connectors from the other laser/scanner assemblies.

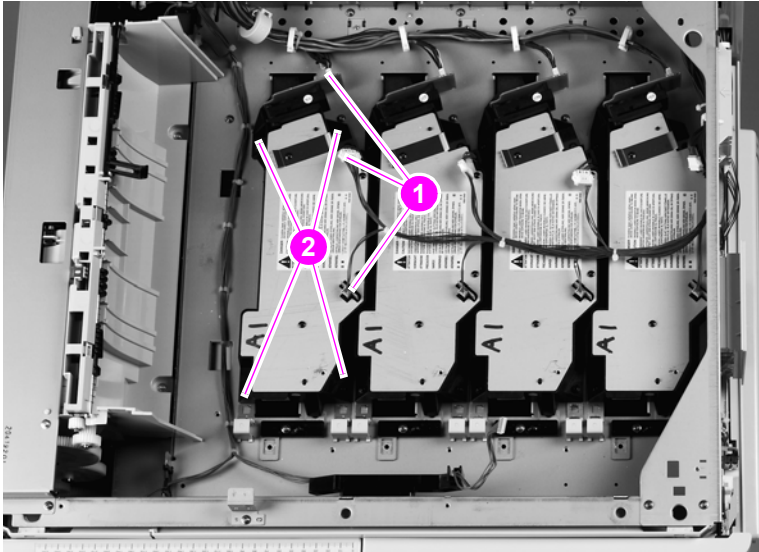

Figure 122. Disconnect a laser/scanner assembly

CAUTION

Do *not* remove the four black screws called out in figure 123.

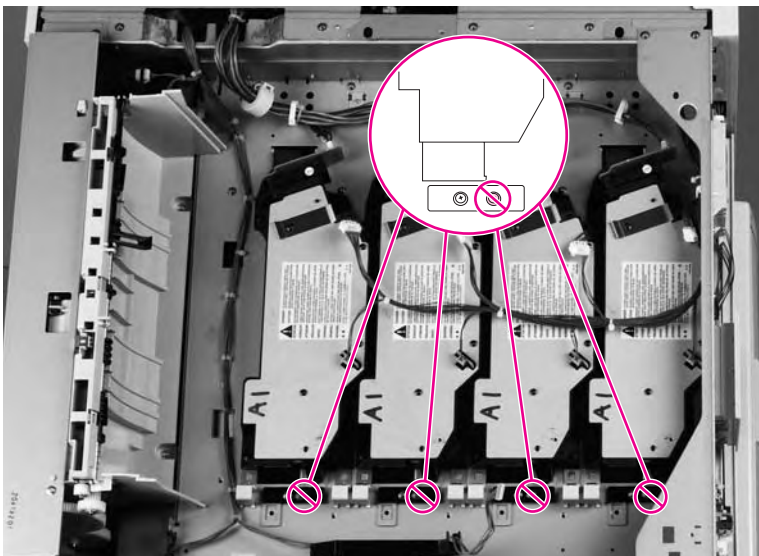

Figure 123. Do not loosen the laser/scanner adjustment screws

- 3 Remove the laser/scanner assembly.

To reinstall

Make sure that the two metal shim stacks (callout 3) are not covering the laser/scanner mounting screw-holes.

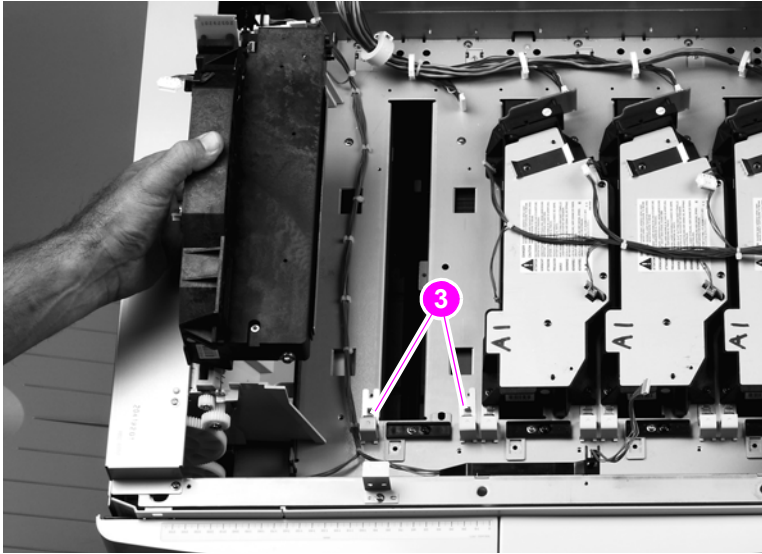

Figure 124. Reinstall the laser/scanner assembly

Note

Print a laser/scanner adjustment test page before reinstalling the top right cover and the top left cover. See page 233.

Printing a laser/scanner adjustment page

Note

A laser/scanner adjustment page can be printed without reconnecting the control panel. However, when the control panel is connected you can read printer error messages (if any errors occur) and know when the printer reaches the `READY` state.

This procedure can only be performed on printer models. It cannot be performed on the MFP version.

This procedure can only be performed using A4- or letter-size media. Using A3 or 11-by-17 media gives invalid results.

Note

MFP only: the control panel cannot be reconnected with the scanner/ADF assembly removed. You must print the laser/scanner adjustment page and make any required adjustments with the scanner/ADF assembly removed.

- 1 Turn the printer off.
- 2 Completely cover the laser/scanner assemblies with two layers of paper to prevent light from leaking into the printer. A light leak might affect the adjustment values on the test page.

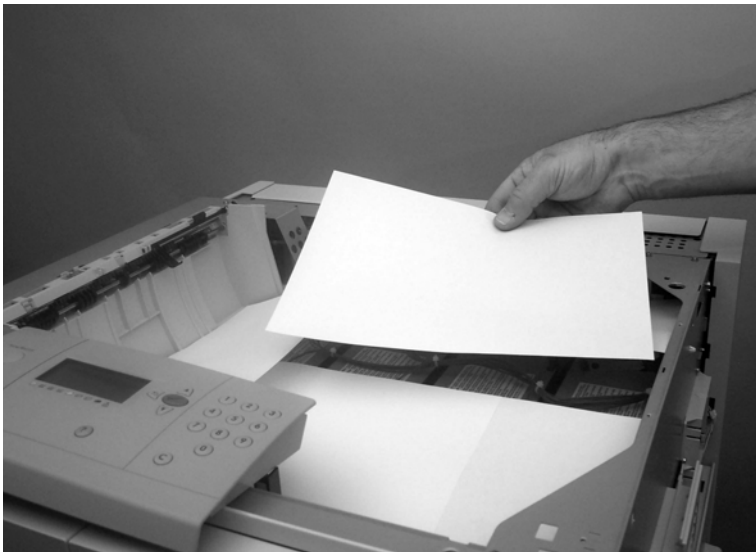

Figure 125. Cover the laser/scanners to prevent a light leak

- 3 Using a small, non-metallic, flatblade screwdriver (or similar tool), depress the engine test button, making sure to press straight in to avoid damaging the DC controller board. Turn the printer on. Continue to depress the test button for about three to five seconds while the printer initializes. Release the engine test button and wait for the printer to come to the `READY` state.



Figure 126. Prepare to print a laser/scanner adjustment page

- 4 When the printer completes its initialization and calibration sequence and it reaches the `READY` state, depress and release the engine test button. The printer performs an internal calibration, and then a laser/scanner adjustment page prints.

Reading a laser/scanner adjustment page

CAUTION

Do not attempt to adjust the laser/scanner assemblies unless the laser/scanner adjustment page indicates that a laser/scanner needs adjustment. See "Printing a laser/scanner adjustment page" on page 233.

Overview

Two possible adjustments can be made to a laser/scanner assembly. These adjustments *must* be made in the correct sequence. The first adjustment is identified as *Laser Scanner Adjustment Step 1* on the laser/scanner adjustment page. The second adjustment is identified as *Laser Scanner Adjustment Step 2* on the laser/scanner adjustment page.

- 1 Look at the laser/scanner adjustment page. If the numbers under the *Laser/Scanner Adjustment Step 1* are all zeros (callout 1; figure 127) and the center of the three gray bands under the *Laser Scanner Adjustment Step 2* are inside of the zero range for all three colors (callout 2; figure 127), then no adjustment is required and this procedure is complete.

Note

The laser/scanner adjustment page has examples to help interpret the position of the gray bands (callout 3; figure 127). An example of "Adjustment required" is located on the left side of the page. An example of "No adjustment required" is located on the right side of the page.

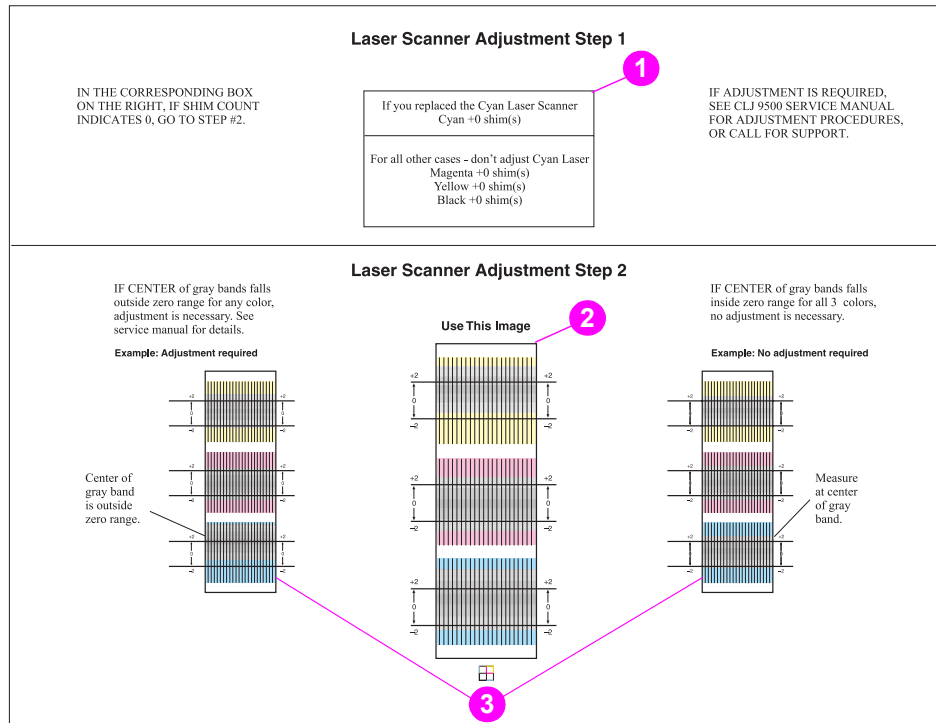

Figure 127. Reading the laser/scanner adjustment page

- 2 If any of the numbers under the *Laser/Scanner Adjustment Step 1* is *not* a zero (callout 4; figure 128) or if the center of any of the three gray bands under the *Laser/Scanner Adjustment Step 2* is outside of the zero range for any of the three colors (callout 5; figure 128), a laser/scanner adjustment is required.

Note

The position of the center of the gray bands under the *Laser/Scanner Adjustment Step 2* are interpreted as shown in figure 128. Callout 6 shows that the center of the gray band for the magenta laser/scanner falls outside of the zero range, meaning that a laser/scanner adjustment is required. Callout 7 shows that the center of the gray band falls inside of the zero range, meaning that a laser/scanner adjustment is not required.

Laser Scanner Adjustment Step 1

If you replaced the Cyan Laser Scanner Cyan +0 shim(s)
For all other cases - don't adjust Cyan Laser Magenta +1 shim(s) Yellow +0 shim(s) Black +0 shim(s)

4

Laser Scanner Adjustment Step 2

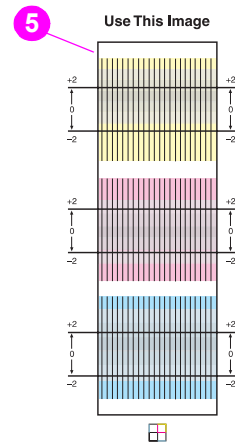

Interpreting Step 2 gray band positioning

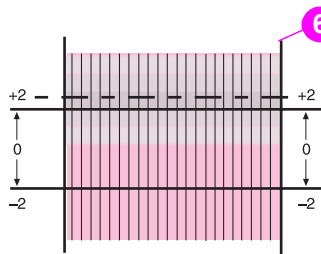

Adjustment required

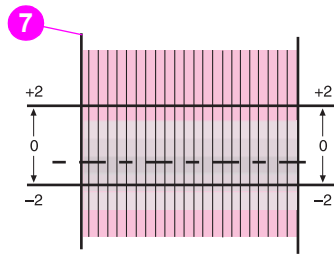

No adjustment required

Figure 128. Interpreting the laser/scanner adjustment page

- 3 If an adjustment is required, see Adjusting the laser/scanner assemblies (page 237).

Adjusting the laser/scanner assemblies

CAUTION

Do *not* attempt to adjust the laser/scanner assemblies unless the laser/scanner adjustment page indicates that a laser/scanner requires adjustments. See "Printing a laser/scanner adjustment page" on page 233.

Overview

Laser/scanners might need to be adjusted if a laser/scanner assembly (RG5-6181-000CN), the process cartridge drive assembly (image drum drive assembly) (RG5-6188-000CN), or the image drum door (RG5-6182-000CN) is replaced.

Adjusting the laser/scanner assemblies requires that you print a laser/scanner adjustment page (see "Printing a laser/scanner adjustment page") and use several special tools that are included with the replacement laser/scanner assemblies, process cartridge drum drive assembly (image drum drive assembly), and image drum door.

Two possible adjustments that can be made to a laser/scanner assembly. These adjustments *must* be made in the correct sequence. The first adjustment is identified as *Laser Scanner Adjustment Step 1* on the laser/scanner adjustment page. The second adjustment is identified as *Laser Scanner Adjustment Step 2* on the laser/scanner adjustment page.

Hint

When adjusting the laser/scanner assemblies you might have to print multiple laser/scanner adjustment pages. Information on the page will change as you make fine adjustments to the laser/scanner assemblies.

Avoid using previously printed pages, which might not reflect the current adjustment of a laser/scanner, by numbering each page after it prints or throwing away previously printed pages. Always make sure that you are using the most recent adjustment page that you printed.

Laser scanner adjustment step 1

CAUTION

Make sure that you do not lose any shims inside the printer. Shims that remain inside the printer can damage the printer.

Hint

If you are unsure of how to interpret the *Laser Scanner Adjustment Step 1* part of the adjustment page, see figure 128.

- 1 Print a laser/scanner page (See "Printing a laser/scanner adjustment page" on page 233).
- 2 Locate the box on the laser/scanner adjustment page under the *Laser Scanner Adjustment Step 1* heading (callout 1). If all of the listed laser scanners indicate that zero shims are needed, the step 1 adjustment is *not* required. Proceed to Laser/scanner adjustment step 2 (page 242).

If any of the results under the *Laser Scanner Adjustment Step 1* heading indicate a number other than zero, proceed to the next step.

Note

If a laser/scanner assembly is replaced, it will usually be the one that requires adjustment. If the cyan laser/scanner is replaced, read the top of the step 1 box and ignore the magenta, the yellow, and the black laser/scanner numbers that are indicated in the bottom half of the box. Make sure that the cyan laser/scanner is adjusted correctly before attempting to adjust the other assemblies. Adjust laser/scanner assemblies one at a time (after the cyan laser/scanner is properly adjusted), printing a new laser/scanner adjustment page after every addition or removal of shims.

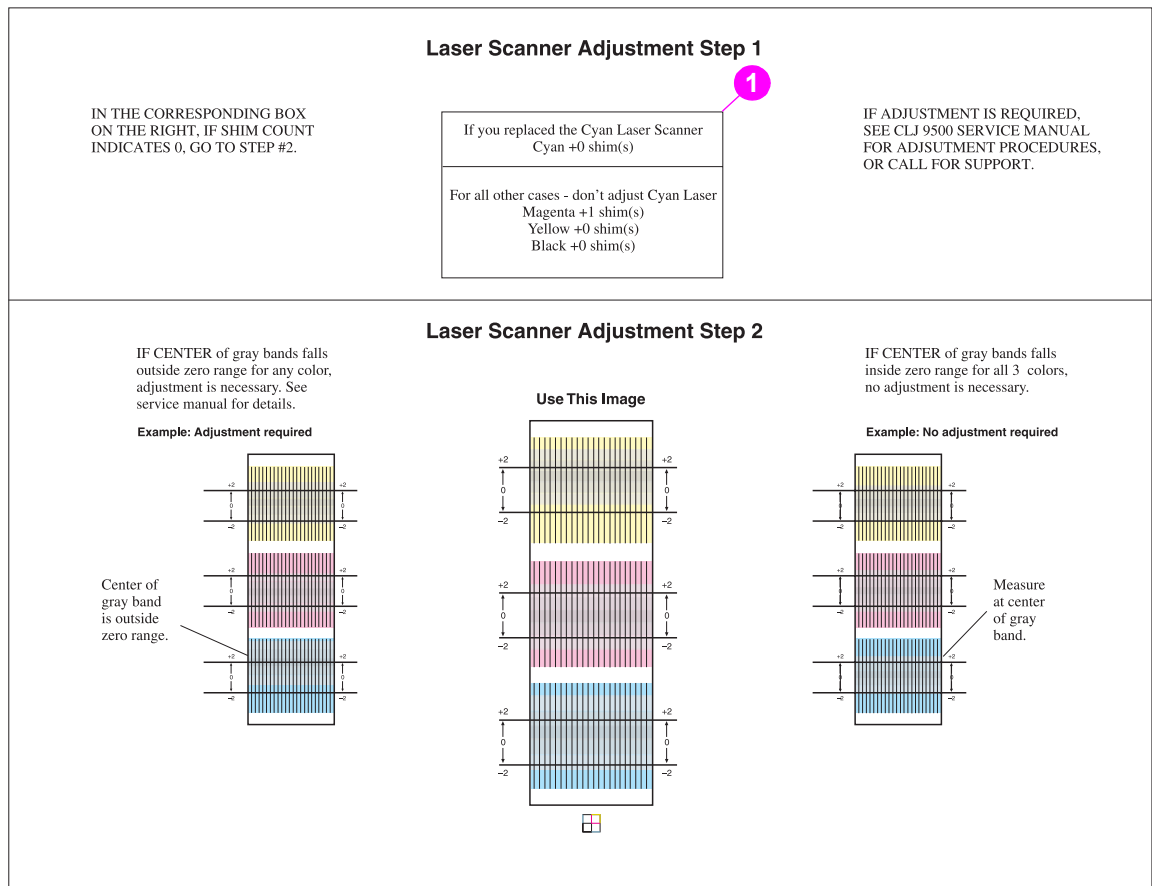

Figure 129. Laser/scanner adjustment page step 1

- 3 Place two S-shims on the edge of the black plastic shim guide (callout 2).

Note

Make sure you do not drop the shims into the sheet-metal opening.

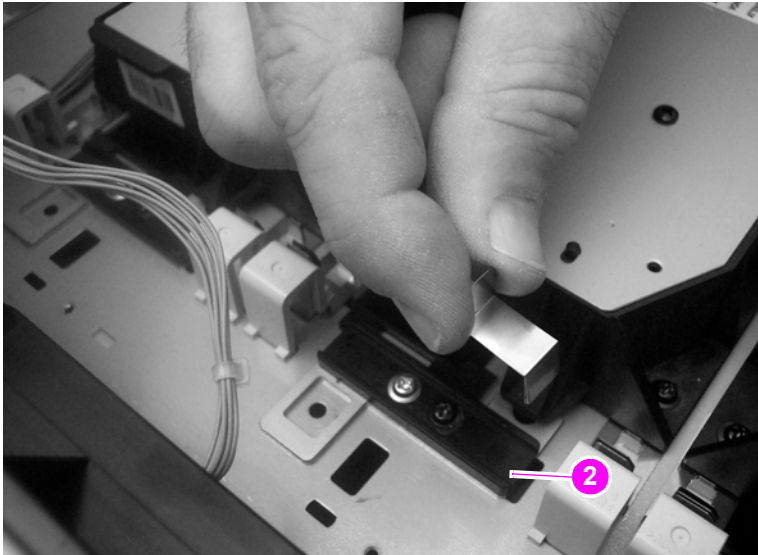

Figure 130. Placing the initial laser/scanner S-shims

- 4 Place the metal adjustment plate (callout 3) in the printer. Loosely secure the plate with a screw.

Note

A screw is not provided with the tool kit. Use one of the screws that you removed when the top covers were removed.

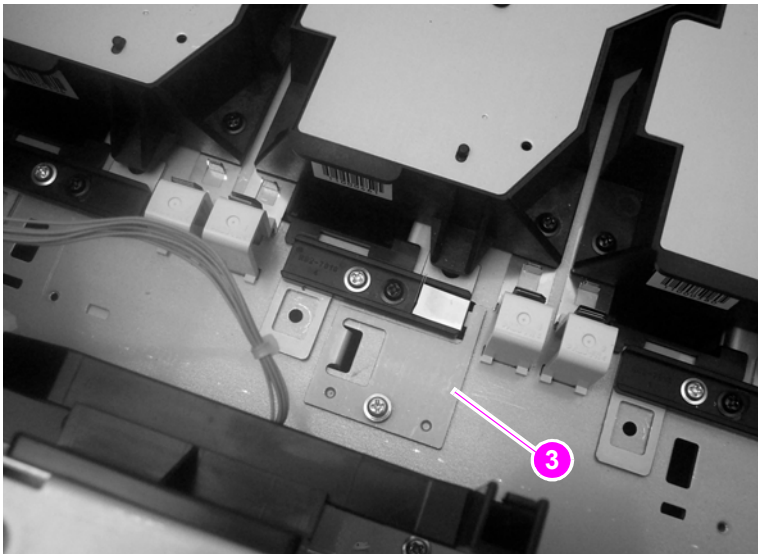

Figure 131. Install the laser/scanner adjustment plate

- 5 Use the spring tool (callout 4) to force the adjustment plate against the shims (callout 5), and then tighten the screw that secures the metal adjustment plate. Remove the spring tool.

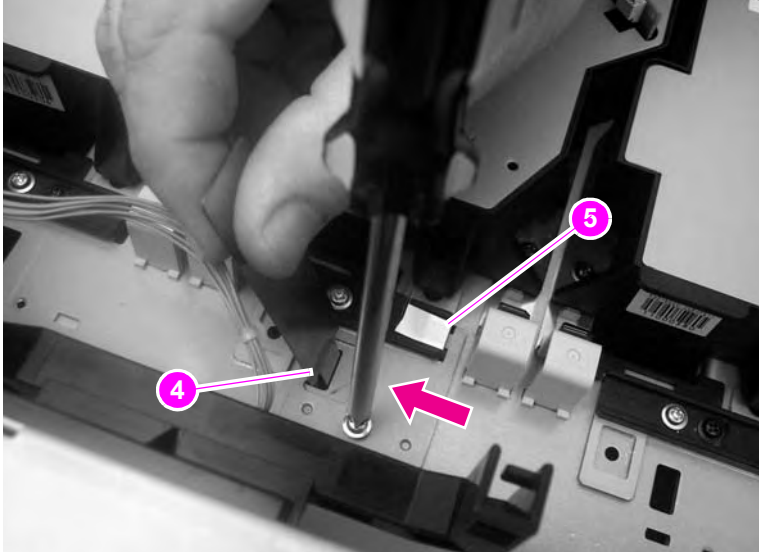

Figure 132. Position the laser/scanner adjustment plate

- 6 Loosen the four black laser/scanner mounting screws (callout 6) and the black laser/scanner adjustment screw (callout 7). Slide the laser/scanner assembly to the left, away from the S-shims.

If you replaced the cyan laser/scanner assembly, look at the top half of the step 1 box on the adjustment page (callout 1 on figure 129). If you replaced any of the other laser/scanner assemblies, look at the bottom half of the step 1 box on the adjustment page (callout 1 on figure 129).

Add or remove the number of S-shims that is indicated on the laser/scanner adjustment page to or from the S-shims on the black plastic shim guide.

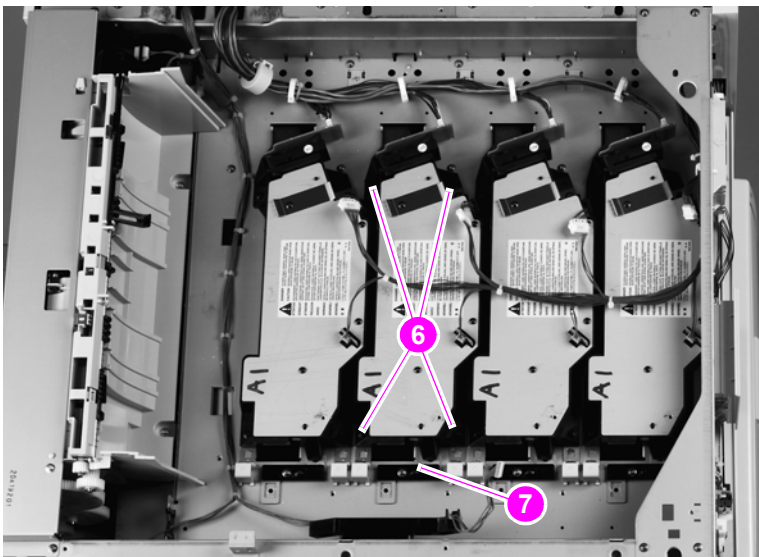

Figure 133. Add or remove laser/scanner adjustment S-shims

- 7 Slide the laser/scanner tightly against the plate and the S-shims (if any remain), and use the spring tool (callout 8) to keep the laser/scanner snug against the plate or the S-shims.

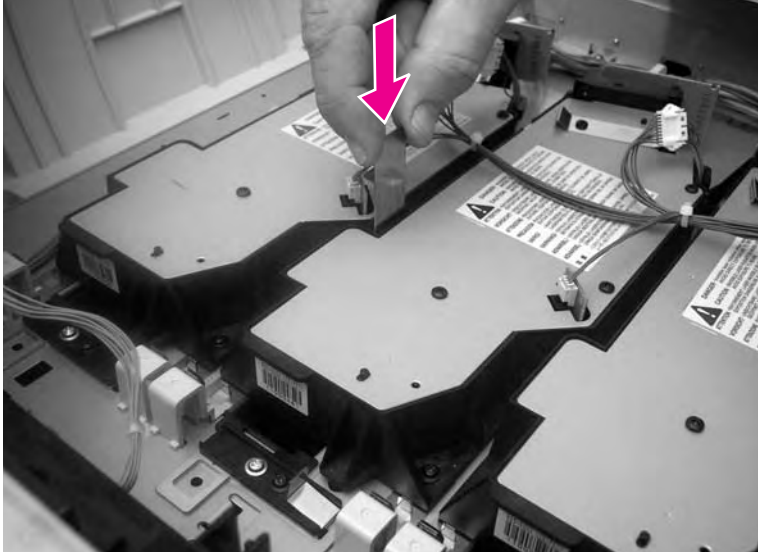

Figure 134. Position the laser/scanner assembly

- 8 Tighten the four black laser/scanner mounting screws (callout 9) and tighten the black adjustment screw (callout 10).

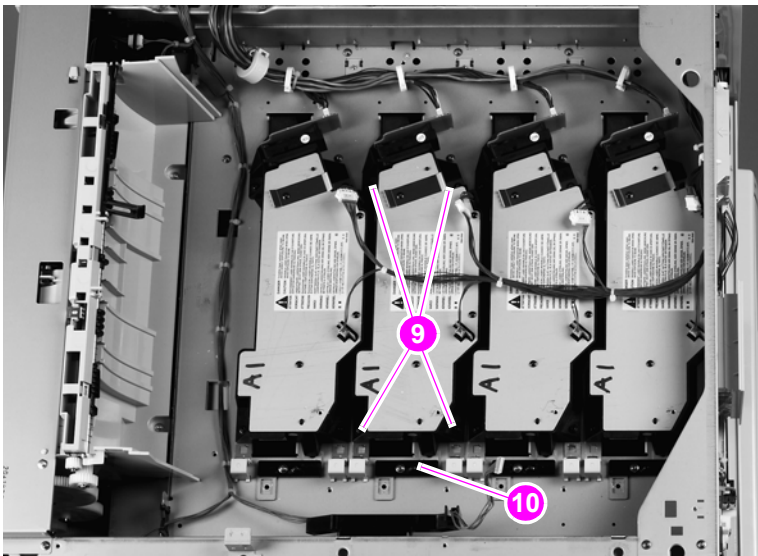

Figure 135. Tighten the laser/scanner assembly mounting screws

- 9 Cover the top of the printer to prevent light leaks, and then print another laser/scanner adjustment page (see page 233). If the numbers under the *Laser Scanner Adjustment Step 1* heading indicate that the laser/scanners do not require further adjustments (all are zeros), the first adjustment is complete.

Note

Make sure that you remove the adjustment plate and screw from the laser/scanner bed.

- 10 If further adjustment is required for the remaining laser/scanner assemblies, repeat *Laser Scanner Adjustment Step 1*.

CAUTION

If the step 1 adjustment must be repeated, make sure you install the first two S-shims.

Laser/scanner adjustment step 2

CAUTION

Make sure that you do not lose any shims inside the printer.

Note

The laser/scanner adjustment page has examples to help interpret the position of the gray bands. An example of "Adjustment required" is located on the left side of the page. An example of "No adjustment required" is located on the right side of the page.

Note

The position of the center of the gray bands under the *Laser Scanner Adjustment Step 2* is interpreted as shown in figure 128. Callout 1 shows that the center of the gray band falls outside of the zero range, meaning that a laser/scanner adjustment is required. Callout 2 shows that the center of the gray band falls inside of the zero range, meaning that a laser/scanner adjustment is not required.

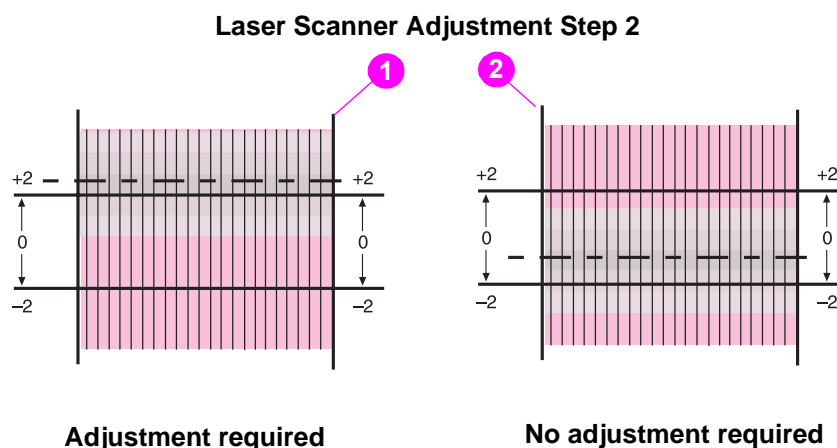

Figure 136. Reading the laser/scanner adjustment step 2 images

- 1 Print the laser/scanner adjustment page (see page 233).
- 2 Locate the box that appears on the adjustment page under the *Laser Scanner Adjustment Step 2* heading (callout 3). If centers of the gray bands are at zero for all three colors, no adjustment is required and the second adjustment is complete.

If the center of the gray bands falls outside of the zero range, adjustment is required. If one of the colors (Y, M, or C) is out of the zero range, adjust the laser for that color as described. If all three colors (Y, M, and C) are out of the zero range in the same direction, you might only have to adjust the black laser. In this case, the number of shims that you add or subtract is the reverse of the indication. That is, you add shims if the indication is negative or remove shims if the indication is positive. Proceed to the next step.

Laser Scanner Adjustment Step 1

IN THE CORRESPONDING BOX ON THE RIGHT, IF SHIM COUNT INDICATES 0, GO TO STEP #2.

If you replaced the Cyan Laser Scanner
Cyan +0 shim(s)

For all other cases - don't adjust Cyan Laser
Magenta +0 shim(s)
Yellow +0 shim(s)
Black +0 shim(s)

IF ADJUSTMENT IS REQUIRED, SEE CLJ 9500 SERVICE MANUAL FOR ADJUSTMENT PROCEDURES, OR CALL FOR SUPPORT.

Laser Scanner Adjustment Step 2

IF CENTER of gray bands falls outside zero range for any color, adjustment is necessary. See service manual for details.

Example: Adjustment required

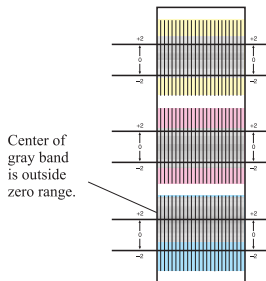

Use This Image

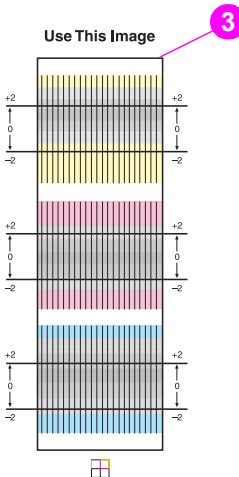

IF CENTER of gray bands falls inside zero range for all 3 colors, no adjustment is necessary.

Example: No adjustment required

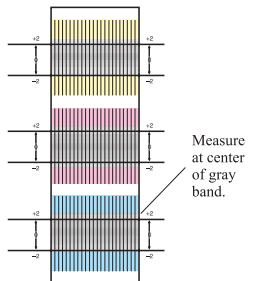

Figure 137. Laser/scanner adjustment page step 2

- 3 Remove the four black laser/scanner mounting screws (callout 4) for the selected laser/scanner.

CAUTION

Do *not* loosen the one black laser/scanner adjustment screw (callout 5).

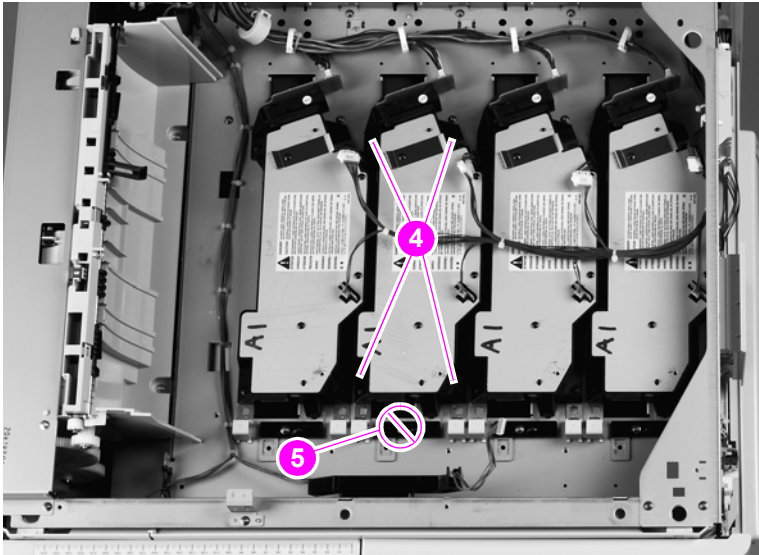

Figure 138. Remove the laser/scanner assembly mounting screws

- 4 Lift up the laser/scanner assembly slightly. Pinch one of the two plastic shim retainers and pull the retainer and shim pile (callout 6) out of the printer. Repeat for the second retainer and shim pile (callout 7).

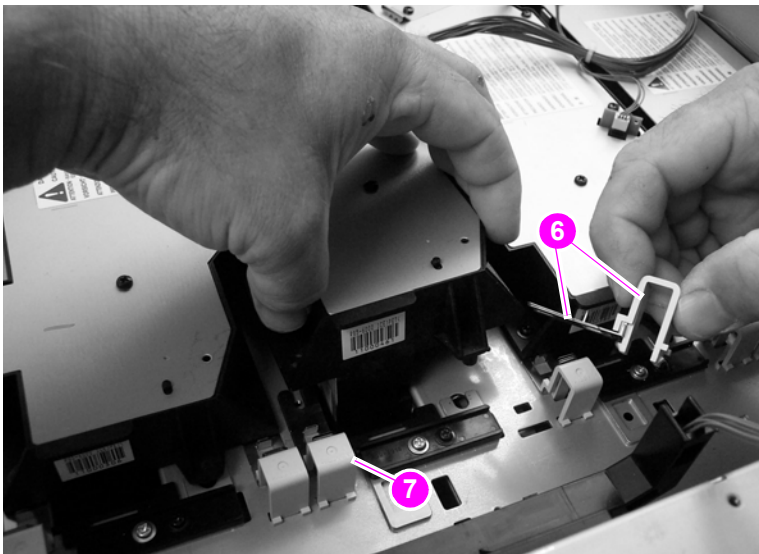

Figure 139. Remove the laser/scanner assembly shim retainers and shims

- 5 Add or remove the required number of shims from the two shim piles.

Note

If all three colors (Y, M, and C) are outside of the zero range by the same amount, you can simply adjust the black laser, rather than the other three, to align all four laser scanners. In this instance, the number of shims added or subtracted is reversed, and black is the reference color for this adjustment.

CAUTION

Always add or subtract shims from the *top* of the shim pile. The bottom shim might include a half-width, factory-installed shim that *must* stay in place.

Make sure that you add or remove the same number of shims from the top of each shim pile. If the number of shims is not equal, the laser/scanner will not be parallel to the printer frame when it is installed.

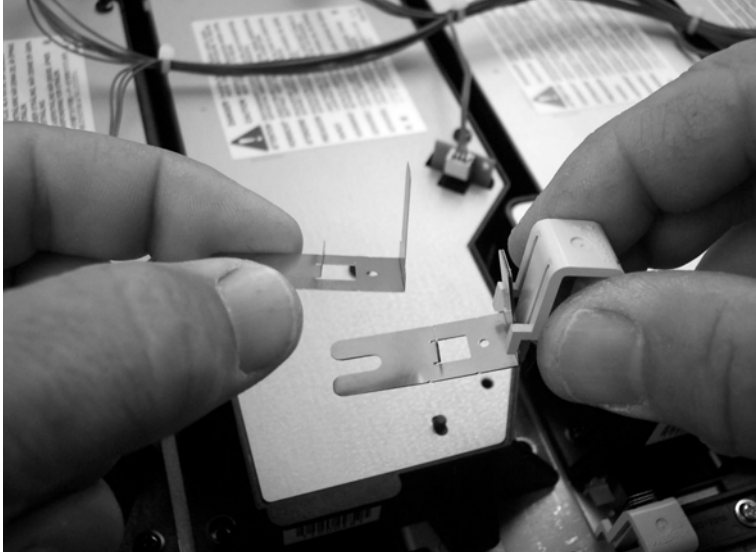

Figure 140. Add or remove the laser/scanner adjustment shims

- 6 Lift up the laser/scanner assembly slightly. Carefully slide the two retainers and shim piles back into position under the left and right side of the laser/scanner assembly. Snap the two plastic shim retainers into place.

CAUTION

Make sure that the shims do not cover the laser/scanner mounting screw-holes. If they cover the holes, the shims might be bent or damaged when the laser/scanner assembly is installed. Dispose of any bent or damaged shims and replace them with smooth, flat, undamaged shims.

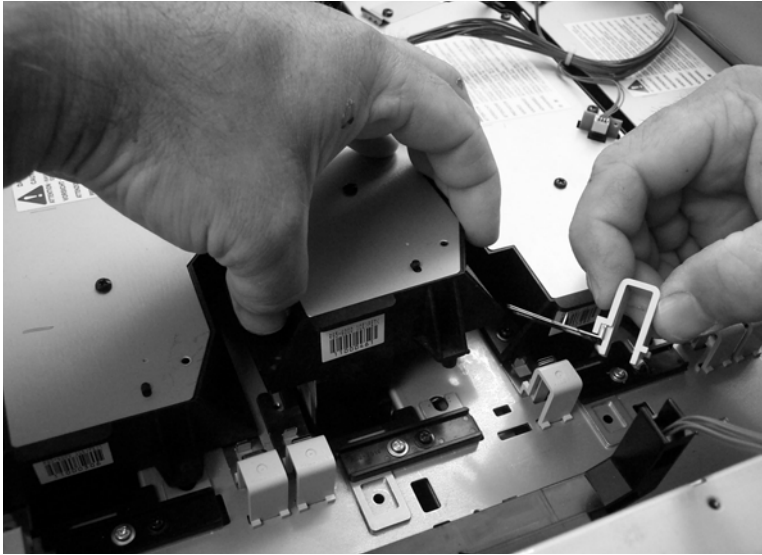

Figure 141. Replace the laser/scanner adjustment shim retainers and shims

- 7 Tighten the four black laser/scanner mounting screws (callout 8).

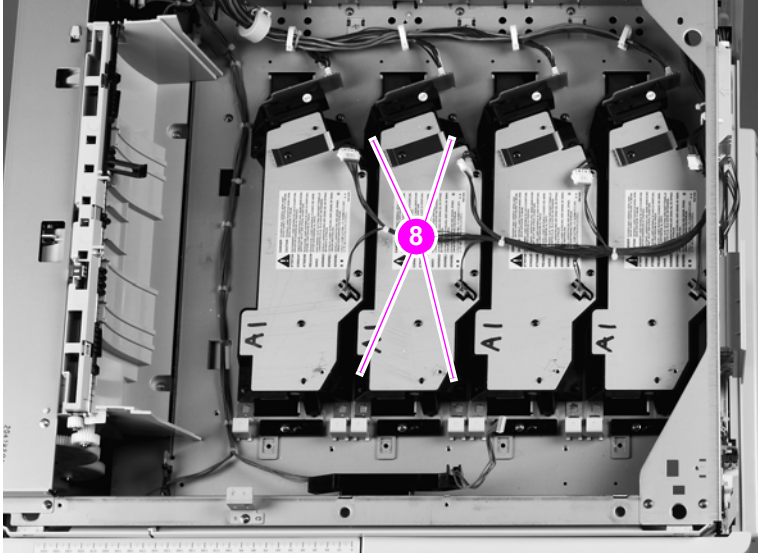

Figure 142. Tighten the laser/scanner assembly mounting screws

- 8 Print another laser/scanner adjustment page (see page 233). Make sure that you cover the top of the printer to prevent light leaks.

CAUTION

Make sure that you do not use previously printed laser/scanner adjustment pages to check for the correct laser/scanner adjustment.

- 9 If all of the centers of the three gray bands under the *Laser Scanner Adjustment Step 2* heading are inside of the zero range for all of the three colors (callout 9), the step 2 adjustment is complete. Replace the printer covers.
- 10 If any of the centers of the three gray bands are outside of the zero range for any of the three colors (callout 9), repeat the step 2 adjustment procedure.

Laser Scanner Adjustment Step 1

IN THE CORRESPONDING BOX ON THE RIGHT, IF SHIM COUNT INDICATES 0, GO TO STEP #2.

If you replaced the Cyan Laser Scanner
Cyan +0 shim(s)

For all other cases - don't adjust Cyan Laser
Magenta +0 shim(s)
Yellow +0 shim(s)
Black +0 shim(s)

IF ADJUSTMENT IS REQUIRED, SEE CLJ 9500 SERVICE MANUAL FOR ADJUSTMENT PROCEDURES, OR CALL FOR SUPPORT.

Laser Scanner Adjustment Step 2

IF CENTER of gray bands falls outside zero range for any color, adjustment is necessary. See service manual for details.

Example: Adjustment required

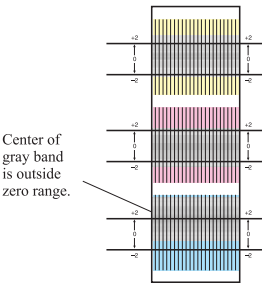

Use This Image 9

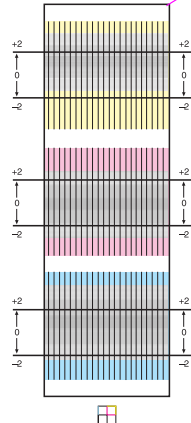

IF CENTER of gray bands falls inside zero range for all 3 colors, no adjustment is necessary.

Example: No adjustment required

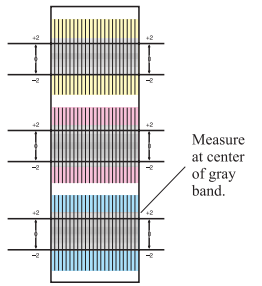

Figure 143. Print another laser/scanner adjustment page