

Building Value in

Air worldwide



 **GREENHECK**
Building Value in Air.



Welcome to Greenheck

As one of over 2,500 Greenheck employees, I want to assure you that our organization is deeply committed to being easy to do business with, anywhere in the world. As an industry-leading manufacturer, our focus is to **build value in air**...by offering the widest range of reliable air movement and control products and to exceed your expectations for on-time delivery, easy installation, performance and operating efficiency. We also pledge to address the industry's most complex challenges and your future needs by introducing innovative new product solutions you can depend on.

President, CEO

Our Mission

To be the market leader in the development, manufacture and worldwide sale of quality air moving and control equipment with total commitment to the customer.

Our Vision

Greenheck will be a company that exceeds customer expectations and that others strive to emulate. We will be the worldwide leader in providing timely, flexible and cost-effective solutions focused on the movement, cleaning, tempering, and control of air.

Building value in air-from the beginning.

Today, we're the world's largest manufacturer of commercial, institutional and industrial air movement and control equipment.

Greenheck's worldwide leadership in providing cost-effective, value-added solutions for air movement and control challenges evolved from rather humble beginnings. Bernie and Bob Greenheck weren't sure what lay ahead when they opened their small sheet metal shop in Schofield, Wisconsin USA in 1947. But they were determined

that no product would ever leave their shop, unless it met the most stringent quality standards—their own. At first, the company manufactured a variety of sheet metal products. In 1956, Greenheck engineers developed a highly efficient power roof ventilator. This product and the innovative ventilation solutions

that followed ultimately enabled us to expand our distribution throughout the world. Today, quality Greenheck products are efficiently moving air in commercial buildings, institutions and factories throughout North America, Latin America, the Middle East, and Asia.



Customer driven employees.

Every Greenheck product is still designed and built with pride of ownership.

Greenheck employees continue to share an extraordinary commitment to meeting our customers' needs. We know our future success depends on the value we bring to the market: reliable, top-quality products

and exceptional service. At our headquarters in Schofield, Wisconsin USA, and at additional plants in Frankfort, Kentucky; Sacramento, California; Charlotte, North Carolina and Kunshan,

China; you'll find over 2,500 hardworking and experienced employees designing, manufacturing and delivering the most dependable air movement and control equipment available.

[Bernie and Bob Greenheck, 1956]

● Manufacturing

Rocklin, CA
Schofield, WI
Frankfort, KY
Charlotte, NC
Kunshan, China

● National Distribution

Schofield, WI
Rocklin, CA
Dallas, TX
Miami, FL
Greensboro, NC
Union, NJ
Columbus, OH
Las Vegas, NV

● International Distribution

China
Mexico
United Arab Emirates

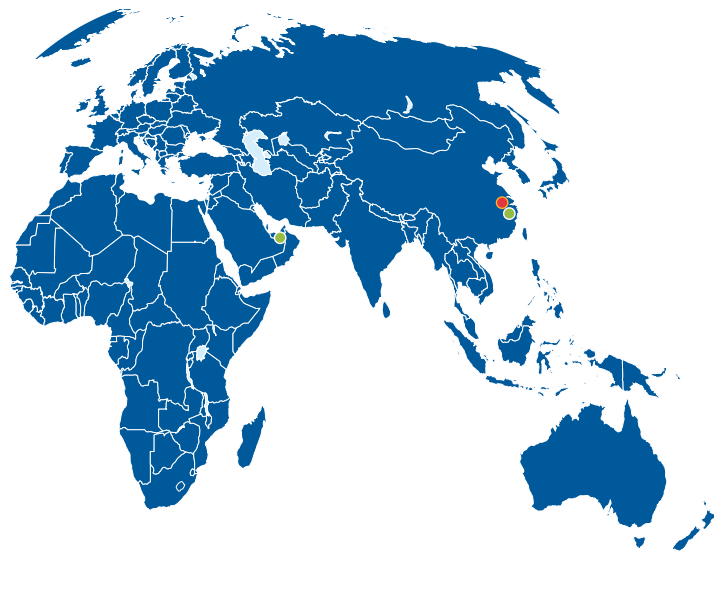



We don't "value engineer" - we engineer value.

Our innovative engineers continuously explore more cost-effective, value-added product solutions.

Our engineers continuously develop and introduce new product solutions based on the input they receive from more than 300 Greenheck manufacturer representatives around the world who listen carefully to what you need. State-of-the-art computer modeling and extensive prototype testing ensure that our newest products offer more efficient performance and easy,

lower-cost installation. Whether it's developing compact, quieter fans with the lowest industry sound levels, kitchen exhaust systems that trap more grease, the most advanced energy recovery ventilators available, or more effective lab exhaust systems, Greenheck engineers always have one goal in mind: deliver value that exceeds your expectations.



Every product we make is thoroughly tested to ensure top performance and unequalled reliability.

Because we test our products so extensively, Greenheck offers more products with certifications from AMCA, UL, ETL, CSA and ULc than any other manufacturer. Our real-life testing procedures measure aerodynamic performance, sound levels, structural integrity, mechanical operation, environmental impact, temperatures, vibration

levels and more. We also offer two on-site third party registered air chambers and a registered sound-testing facility. In addition, Greenheck tests new fire Life Safety Damper products in our on-site UL-certified testing lab. We can also test louver and damper performance on-site with extensive dynamic water tests and missile impact tests.

Bearings, pulleys and motors must also meet the industry's highest standards for reliability and endurance.





Your single source for the world's most comprehensive line of top-quality air movement and control products.

No other manufacturer offers you as many options for air movement and control as Greenheck. Specifying engineers and contractors can rely on us for products that stand at the forefront of technology and performance. To maintain your trust, we assign a knowledgeable product manager, a talented group of engineers and an experienced customer service team to each of the following eight product groups:

- Fans and Ventilators
- Centrifugal and Vane Axial Fans
- Energy Recovery Ventilators
- Make-Up Air Units
- Kitchen Ventilation Systems
- Dampers
- Louvers
- Lab Exhaust Systems

Our engineers design and build many of our machines and dies to accommodate the unique value-added features you'll find in our products. In addition, state-of-the-art, numerically controlled manufacturing systems and a highly efficient, experienced production staff help Greenheck meet the most challenging delivery requirements in the industry. To keep up with the worldwide demand for our products, we operate and maintain 1.3 million square feet of manufacturing space.



[When you specify Greenheck, you're specifying quality.]





[Greenheck Product Center, Schofield, WI]

The value of Greenheck customer service

We want to be the easiest company you'll ever do business with.

Giving you the level of customer service that distinguishes us from our competitors has always been a hallmark at Greenheck. Greenheck makes it easy for you to access all the technical information you'll need

to specify and select our products. You can go to our Web site at greenheck.com, navigate our comprehensive product and technical binders or request CAPS - our innovative Computer-Aided Product

Selection Program. In addition, we offer Internet-based seminars. And of course, you're always welcome to take a plant tour and visit our spectacular Greenheck Product Center in Schofield, Wisconsin.



Most products can be shipped in less than 24 hours.

Distribution centers around the world ensure that Greenheck products are readily available.

Today, even our most complex ventilation systems and largest products can be built in less than 10 days, and many products can be built and shipped the next day. Greenheck also provides an efficient Quick Delivery in-stock program that ships products to

your job site in less than 24 hours. In fact, most orders received before noon can be shipped the same day! Stocking warehouses at our manufacturer's representatives are backed up by strategically located Greenheck distribution centers around the world.

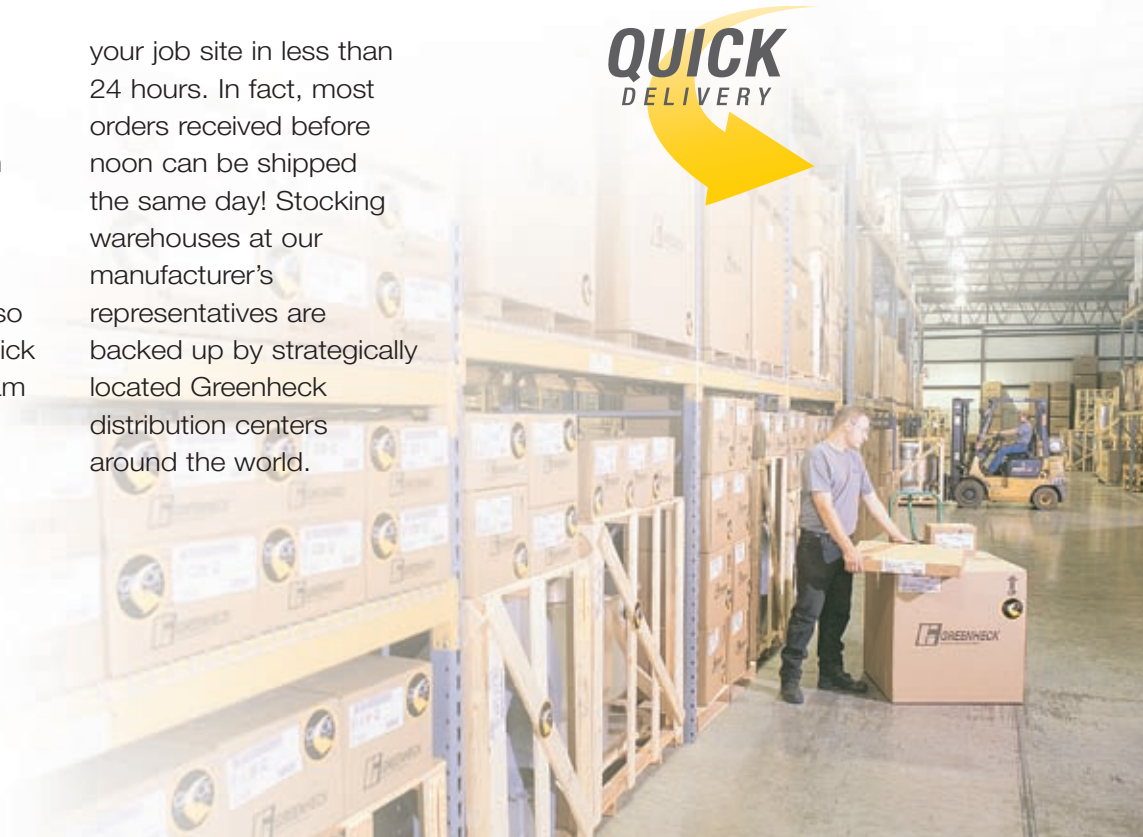

Our Product Lines

Engineered and manufactured for top performance - and value.

Fans & Ventilators

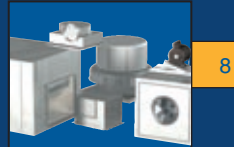

8

Centrifugal Fans



15

Vane Axial Fans



18

Laboratory Exhaust Systems



20

Dampers



22

Louvers



26

Kitchen Ventilation Systems



30

Energy Recovery Ventilators



34

Make-Up Air



36

Fans and Ventilators



Greenheck offers the world's widest selection of top quality fans and ventilators for commercial, institutional and industrial buildings. And that means you can always find the right fan to meet your precise performance requirements. Discover Greenheck value in the world's best-selling centrifugal roof upblast and exhaust fans with one-piece leakproof construction. Or experience Greenheck reliability in our lighted ceiling fans, and our many other fan and ventilator products.

Centrifugal Roof Exhaust Fans

The Centrifugal Roof Exhaust Fans include both direct and belt driven fans with backward inclined centrifugal wheels. The fans feature double studded isolators for true vibration isolation. The fans are a downblast configuration and are suitable for roof mounted applications exhausting relatively clean air. There are four different architectural looks to choose from.

Models G/GB

The housing available is a spun aluminum style. Capacities range from 75 to 44,000 cfm and up to 3.25 in. wg.

Catalog: Centrifugal Roof Exhaust Fans (Models G and GB)

Models H-G/H-GB

The housing is spun aluminum style specifically designed for high wind and hurricane zone applications where winds approach 150 mph. Capacities up to 14,000 cfm.

Catalog: Centrifugal Roof Exhaust Fans (Model H-GB)



Models LD/LB

The housing style is a low silhouette with "rib-lock" construction. Capacities range from 80 to 37,500 cfm and up to 1.25 in. wg.

Catalog: Centrifugal Roof Exhaust Fans (Series L)



Models LDP/LBP

The housing style is a louvered penthouse design which features extruded aluminum louvers. Capacities range from 80 to 37,000 cfm and up to 1.25 in. wg.

Catalog: Centrifugal Roof Exhaust Fans (Series L)

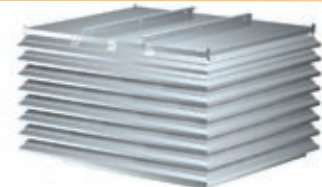

Models NYD/NYB

These fans feature tamper resistant housings while also allowing ease of access for service. Capacities range from 170 to 8,050 cfm and up to 1.00 in. wg.

Catalog: Centrifugal Roof Exhaust Fans (Models NYD and NYB)



Centrifugal Roof Upblast and Sidewall Exhaust Fans

The Centrifugal Roof Upblast and Sidewall Exhaust Fans include both direct and belt driven fans with backward inclined centrifugal wheels. The motors on the fans are out of the airstream. The fans are suitable for applications ranging from storage rooms to fume hood exhaust, from kitchen grease exhaust to smoke control.

Models CUE, CUBE - Roof Mounted Models CW, CWB - Sidewall Mounted

These spun aluminum fans are specifically designed for roof mounted (CUE/CUBE) or sidewall mounted (CW/CWB) applications. Contaminated or grease laden exhaust air is discharged directly upward, away from the roof surface or discharged out and away from building walls. The fans feature a one piece windband continuously welded to the curb cap and double studded isolators for true vibration isolation. Capacities range from 80 to 30,000 cfm.

Catalog: *Centrifugal Exhaust Fans (Series C)*

Model S-CUBE

The S-CUBE is a spun aluminum fan specifically designed for Emergency Smoke Control Systems. This fan is UL Listed for 500° F. for 4 hours and 1,000° F. for 15 minutes. Capacities range from 1,000 cfm to 30,000 cfm and up to 2.5 in. wg. Available in Upblast configuration only.

Catalog: *Roof Power Ventilators for Smoke Control Systems (Model S-CUBE)*



Model USGF

Model USGF (Ultimate Steel Grease Fan) is the ideal fan for heavy grease exhaust applications as stated in NFPA's Chapter 11 restaurants and food service where high amounts of grease and/or solid fuels are used like char broilers, solid fuel cooking, and oriental cooking. Constructed of steel, the model USGF includes a non-stick coated steel wheel, steel windband, steel curb cap, and steel motor compartment. Standard features include UL-762, a heat baffle, clean-out port, dual belt and pulley system, and a mounted and wired NEMA-3R disconnect switch. The unit is powder coated for protection. Performance capability up to 3 in. wg and 7,000 cfm.

Catalog: *Ultimate Steel Grease Fan (Model USGF)*



Models H-CUE/H-CUBE

These spun aluminum fans are specifically designed for high wind and hurricane zone applications where winds approach 150 mph. Capacities up to 14,500 cfm.

Catalog: *Centrifugal Exhaust Fans (H-CUBE)*



Model TCBRU

The TCBRU is a belt drive upblast roof exhaust fan. It features a tapered outlet which creates high outlet velocities to carry contaminated exhaust away from nearby make-up air units. Capacities range from 360 to 24,000 cfm and up to 4.5 in. wg.

Catalog: *Tubular Centrifugal Fans (Models TCB/TCBRU/TCBRS)*



Centrifugal Roof Supply Fans

The Centrifugal Roof Supply Fans include filtered and non-filtered belt driven units. These fans are suitable for non-tempered kitchen make-up air or building supply air.

Model SAF

This filtered roof supply fan features a belt driven, double width, forward curved, galvanized wheel for low cost, low sound, and high performance applications. Capacities up to 14,000 cfm and up to 3.5 in. wg.

Catalog: Roof Supply Fans (Model SAF)



Models RSF/RSFP

These fans feature forward curved wheels designed for high efficiency and low sound. Housing styles include a straight sided hood (RSF) or a louvered penthouse which features extruded aluminum louvers (RSFP). Capacities range from 650 to 14,300 cfm and up to 2.0 in. wg.

Catalog: Models RSF and RSFP Forward Curved Centrifugal Roof Supply Fan

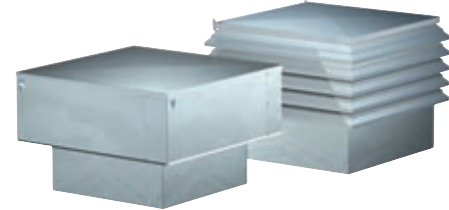

Models LSF

The LSF features a double width centrifugal blower with a backward inclined wheel to efficiently supply filtered air at pressure up to 5.5 in. wg. The aluminum louvered penthouse is available with a standard machine finish or multiple decorative coatings for aesthetics. Airflow volumes range from 800 to 37,000 cfm.

Catalog: Louvered Roof Supply Fans (Model LSF)



Models TCBRS

The TCBRS features aluminum backward inclined wheels for quiet and efficient supply airflow. Greenheck's Fabra-Hood housing on this model provides a strong, weather tight cover, and is available with filters. Capacities range from 360 to 24,000 cfm and 4 in. wg.

Catalog: Tubular Centrifugal Fans (Models TCB/TCBRU/TCBRS)



Centrifugal Ceiling and Cabinet Fans

The Ceiling and Cabinet Fans include both direct and belt driven fans. The fans have forward curved wheels for low sound and high efficiency. They are suitable for clean air applications such as bathrooms, storage rooms, or offices.

Model SP

Model SP is a direct drive ceiling exhaust fan designed for clean air applications where low sound levels are required. Many options and accessories are available such as lights, motion detectors, ceiling radiation dampers and speed controls. These fans may be easily converted from horizontal to a vertical discharge. Capacities range from 30 to 1,607 cfm and up to 1.0 in. wg.

Model CSP

Model CSP is a direct drive inline exhaust fan designed for clean air applications where low sound levels are required. These fans may be easily converted from horizontal to vertical discharge. Capacities range from 77 to 3,778 cfm and up to 1.0 in. wg.

Catalog: Ceiling Exhaust and Inline Cabinet Fans (Models SP and CSP)



Model BDF

Model BDF is a belt drive duct fan designed for efficiency and reliability in supply, exhaust, or return air applications. Capacities range from 400 to 17,000 cfm and up to 2.5 in. wg.

Catalog: Belt Drive Duct Fan (Model BDF)

Model BCF

The model BCF is a belt drive inline low profile cabinet fan. It is designed for efficiency and reliability in supply, exhaust, and ducted return applications. It can be mounted vertically or horizontally with either a top horizontal or upblast discharge. Capacities range from 170 to 5,875 cfm and up to 1.5 in. wg.

Catalog: Belt Drive Cabinet Fans (Model BCF)



Centrifugal Inline Fans

The Centrifugal Inline Fans include both direct and belt driven fans with backward inclined centrifugal wheels. Models feature rugged construction, high efficiency, and low sound levels. Centrifugal Inline Fans are ideal for clean air applications, including intake, exhaust, return, or make-up air. They have straight through airflow with compact size and have the flexibility to be mounted in any configuration—horizontal, vertical, or at any angle.

Models SQ/BSQ

The SQ/BSQ has a square housing design for indoor applications. Easy access for inspection and service is provided by removable side panels. Fans can be configured to discharge air 90° from the inlet for tight space constraints. Capacities range from 62 to 26,600 cfm and up to 3.5 in. wg.

Catalog: Centrifugal Inline Fans (Models SQ and BSQ)

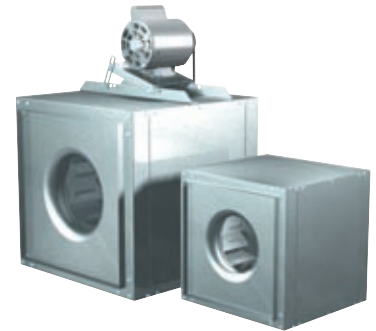

Model TCB

The TCB is a belt driven fan that has a tubular design and can be mounted in either indoor or outdoor applications. In addition to clean air applications, this fan is suitable for combustion air or fume hood exhaust. Capacities range from 360 to 24,000 cfm and up to 4.5 in. wg.

Catalog: Tubular Centrifugal Fans (Models TCB/TCBRU/TCBRS)



Centrifugal Utility Fans

The Utility Fans include both direct and belt driven fans. They are self-contained units consisting of the fan, motor, and drive for a variety of commercial and light industrial applications.

Models SFD/SFB

The SFD (direct drive) and SFB (belt drive) feature quiet and efficient forward curved wheels. These fans are suitable for ducted exhaust, supply, and return-air applications with clean air. Capacities range from 230 to 20,000 cfm and up to 2.5 in. wg.

Catalog: Centrifugal Utility Fan (Models SFD and SFB)



Model SWB

The SWB is a belt driven fan and features a backward inclined centrifugal wheel. This fan is suitable for ducted exhaust, supply, and return-air applications. Typical applications include commercial kitchens, fume hoods, and emergency smoke control installations. Available in galvanized, aluminum, or painted construction. Capacities range from 50 to 23,000 cfm and up to 5.0 in. wg. AMCA licensed for Air Performance.

Catalog: Centrifugal Backward Inclined (Model SWB)

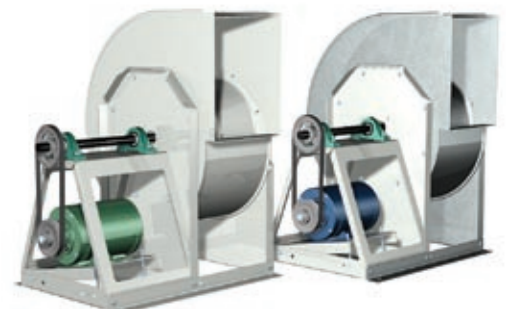

Propeller Sidewall Fans

The Sidewall Propeller Fans include both direct and belt driven fans with fabricated steel, aluminum, or cast aluminum blades. These fans are suitable for clean air applications, including exhaust, supply, or filtered supply. Typical applications are factories and warehouses.

Models S1/S2/SC3/SB/SBC

Sidewall propeller fans are available with a wide variety of accessories including wall housings, wall collars, guards, dampers, and weatherhoods. Capacities range from 100 to 87,000 cfm and up to 1.0 in. wg.

Catalog: Sidewall Propeller Fans

Models SCR3/SBCR

Reversible sidewall fans offer the ability to exhaust or supply air on demand. Performance is equivalent in both the exhaust and supply modes. Capacities range from 3,400 to 80,000 cfm and up to 0.75 wg.

Catalog: Reversible Sidewall Propeller Fans

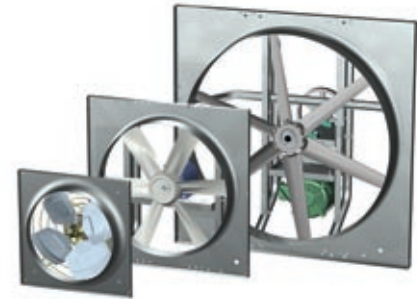

Model CBF

Model CBF is designed for economy and reliability in limited space applications. Fits in lieu of standard 16 in. by 8 in. concrete block. Works great for ventilating equipment rooms and chases. Capacities range from 500 cfm and up to 0.4 in. wg.

Catalog: Model CBF Transfer Fan



Propeller Hooded Roof Fans

The Propeller Hooded Roof Fans include both direct and belt driven fans with fabricated steel, fabricated aluminum, or cast aluminum blades. These fans are suitable for clean air applications, including exhaust, supply, or filtered supply. Typical applications are factories and warehouses.

Models R2/RC3/RB/RBC

Propeller Hooded Roof Fans are available with a wide variety of accessories including tall bases, dampers and guards. Capacities range from 200 to 82,300 cfm and up to 1.5 in. wg.

Catalog: Hooded Propeller Roof Fans

Models RPDR/RPBR

The RPDR/RPBR is compatible with ducted and non-ducted systems and offers the ability to exhaust or supply air on demand. Performance is equivalent in both the exhaust and supply modes. Capacities range from 2,900 to 70,500 cfm and up to 0.5 in. wg.

Catalog: Reversible Propeller Roof Fans (Models RPDR/RPBR)



Models AE/AS

Axial roof exhaust and supply fans are designed for low volume, low pressure applications where a spun aluminum hood is desired. Capacity is up to 5,700 cfm and up to 1 in. wg.

Catalog: Propeller Hooded Roof Fans - Series A (Model AE/AS)

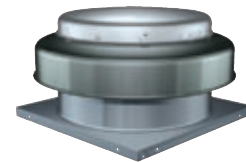

Propeller Recirculating Roof Fans

The Propeller Recirculating Roof Fans include direct driven fans with and without filters. These fans have cast aluminum blades and are available with optional control centers. Suitable for clean air applications, such as factories and warehouses.

Models ESRMD/ERD

The ESRMD, also called the Four-Way fan, offers the flexibility to meet changing needs brought on by production processes or seasonal shifts by exhausting, supplying, recirculating, or mixing air as required. Performance is equivalent in all four modes of operation. Capacities range from 2,800 to 42,700 cfm and up to 0.375 in. wg.

Catalog: Recirculating Roof Fans (Models ESRMD, ESRMF and ERD)



Propeller Tube Axial Fans

The low to medium pressure Tube Axial Fans include both direct and belt driven fans with cast aluminum or fabricated steel blades. Propeller Tube Axial Inline Fans have a straight through airflow, compact size and the flexibility to be mounted in any configuration—horizontal, vertical, or any angle. These fans are designed for reliable air movement in ducted commercial and industrial applications. The Roof Upblast configuration is designed to discharge contaminants up and away from the building in most applications. Where indicated below, models are available in both configurations.

Models RDU/RBU/RBUMO - Roof Upblast

The RBUMO has its motor mounted out of the airstream and is suitable for high temperature emergency smoke removal. The RBU/RBUMO has steel blades, and the RDU has cast aluminum blades. Capacities range from 2,600 to 64,300 cfm and up to 1.0 in. wg.

Catalog: Propeller Upblast Roof Fans (Models RDU/RBU/RBUMO)

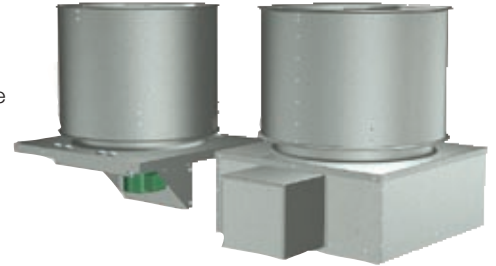

Models TAUD/TAUB-CA - Roof Upblast

The TAUD/TAUB-CA has cast aluminum blades. Typical applications involve clean air, fume exhaust, and spark resistant construction. Capacities range from 2,400 to 74,000 cfm and up to 1.25 in. wg. For higher pressure capabilities use Roof Mounted option on models TDI/TBI-CA or AX.

Catalog: Tube Axial Roof Upblast Models TAUD & TAUB-CA



Model TAUB-L/H - Roof Upblast

The TAUB-L/H has its motor mounted out of the airstream and is suitable for high temperature emergency UL smoke removal. Typical applications involve clean air, industrial processes, and high temperature exhaust. The TAUB-L/H has steel blades. Capacities range from 4,000 to 66,800 cfm and up to 1.0 in. wg. For higher pressure capabilities use Roof Mounted option on model TBI-FS.

Catalog: Tube Axial Roof Exhausters (Models TAUD/TAUB)

Models TDI/TBI-CA - Inline or Roof Upblast

Axial fans with cast aluminum hub and airfoil blades. Universal Mounting System allows for vertical or horizontal installations. Typical applications involve clean air, fume exhaust, and spark resistant construction. AMCA licensed for Air Performance. Capacities range from 800 to 95,000 cfm and up to 3.25 in. wg.

Catalogs:

- Tube Axial Inline Fans (Models TDI & TBI-CA Level 3)
- Medium Pressure Axial Fans (Model TBI-CA Level 4 & 5)



Models TBI-FS - Inline or Roof Upblast

The TBI-FS has a fabricated steel hub and airfoil blades. It is suitable for continuous high temperature (400° F. / 204° C. max.) for inline configurations, (500° F. max.) for roof upblast configuration and is available with UL Power Ventilators for Smoke Control. The Universal Mounting System accommodates any vertical or horizontal installation configuration. Typical applications involve clean air, industrial processes, and high temperature exhaust. AMCA licensed for Sound and Air Performance. Capacities range from 3,300 to 76,000 cfm for inline configurations (5,500 to 74,000 cfm for roof upblast configurations) up to 3.5 in. wg. Bolt-on straightening vanes are available for increased efficiency.

Catalog: Tube Axial Fan (Model TBI-FS)

Model AX - Inline or Roof Upblast

The AX features a cast aluminum hub and airfoil blades which have manually adjustable blade pitch. Universal Mounting System allows for vertical or horizontal installations. Typical applications include clean air and are available with UL Power Ventilators for Smoke Control and UL-705. AMCA licensed for Air Performance. Capacities range from 500 to 150,000 cfm and up to 5.5 in. wg. Bolt-on straightening vanes (AX-V) are available for increased efficiency.

Catalog: Model AX



Propeller Mancoolers

Mancooler fans are direct drive, tube axial fans designed for applications where localized air direction and circulation are required. Three mounting arrangements offer maximum directional flexibility and ease of mounting.

Model DF (Dock Fan)

Model DF is a high velocity dock fan designed to recirculate air in and around loading docks, trailers, and personnel working in the area. The DF is mounted on a 30 in. arm to aid in maneuvering the unit. A light is mounted on the top of the arm to provide additional lighting.

Catalog: Dock Fan (Model DF)

Models MCY/MCB/MCP

Options include beam (MCY), base (MCB), and portable (MCP) mounts. Capacities range from 3,000 to 37,600 cfm of free air.

Catalog: Mancoolers (Model MC)



Gravity Ventilators

The Gravity Intake and Relief ventilators are non-powered and work on pressure differential between the inside and outside of the building.

Models FHI/FHR

The FHI (intake) and FHR (relief) have the low silhouette Fabra Hood design. The Fabra Hood design is superior in appearance, load bearing strength, weather resistance, and dimensional flexibility.

Catalog: Gravity Fabra Hoods (Models FHI/FHR)

Models GRS

Model GRS is an aluminum ventilator designed to be used as an intake or relief unit on natural gravity systems. The GRS appearance blends with other Greenheck products, and with its low silhouette, avoids the problem of detracting from architectural aesthetics.

Catalog: Gravity Ventilators (Models GRS/GRSI)

Models WIH/WRH

Model WIH is available for intake requirements. These units feature a stormproof aluminum louver with mitered corners. The louver design affords lower pressure drops while maintaining low hood heights. The all-aluminum construction assures lasting durability and appearance. The removable hood is lined with insulation to prevent condensation.

Catalog: Louvered Penthouses (Models WIH/WRH)

Model RGU

The RGU gravity upblast ventilator is designed for use as a weatherproof outlet on vertical, high velocity exhaust systems.

Catalog: Propeller Upblast Roof Fans (Models RDU/RBU/RBUMO)

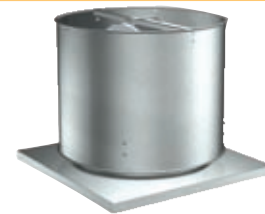
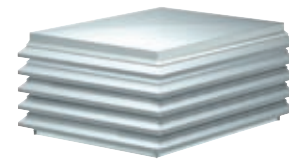
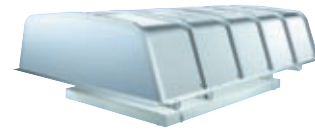

Roof Curbs

Many different sizes and heights are available and can be constructed of galvanized steel or aluminum.

Roof Curbs

Roof curbs are used as roof support structures for fans and ventilators. Curbs are available for flat, pitched, and ridged roofs with or without insulation. Curbs can be either canted or straight-sided.

Extended Bases

Extended bases fulfill additional height requirements between the fan and roof curb.

Sound Curbs

Sound curbs are available to decrease noise penetration into the building.

Equipment Supports

Designed to support equipment that would not be curb mounted.

Adapters/Reducers

Adapters and reducers are available to fit a new fan to an existing roof curb.

Catalog: Roof Curbs, Extensions and Equipment Supports

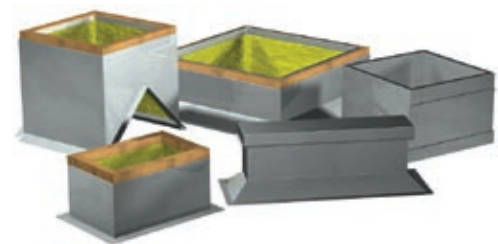

Centrifugal Fans

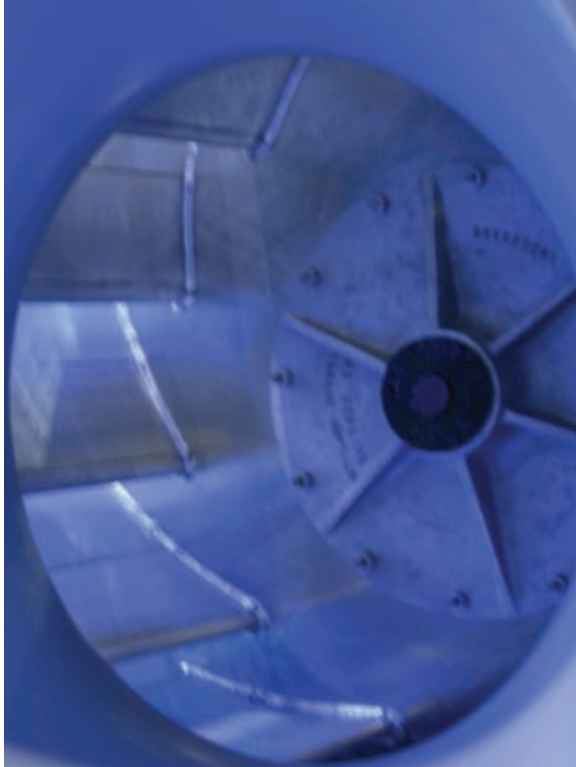

Greenheck offers a complete line of heavy-duty centrifugal and mixed flow fans for any commercial HVAC and industrial application you may encounter. Greenheck centrifugal and mixed flow products are used for everyday commercial applications such as providing supply, exhaust, and return air in hospitals, schools, and large office buildings or fume exhaust for laboratories and pharmaceuticals. These products are also well suited for industrial applications involving high temperature process exhaust, filtration systems, corrosive air exhaust, and material handling.

Utility Fans

The Utility Fans include both direct and belt driven fans. They are self-contained units consisting of the fan, motor, and drive.

Models SFD/SFB

The SFD (direct drive) and SFB (belt drive) feature quiet and efficient forward curved wheels. These fans are suitable for ducted exhaust, supply, and return-air applications with clean air. AMCA licensed for Air Performance. Capacities range from 230 to 20,000 cfm and up to 2.5 in. wg.

Catalog: Centrifugal Utility Fans (Models SFD and SFB)

Model SWB

The SWB is a belt driven fan and features a backward inclined centrifugal wheel. This fan is suitable for ducted exhaust, supply, and return-air applications. Typical applications include commercial kitchens, fume hoods, and emergency smoke control installations. Available in galvanized, aluminum, or painted construction. Capacities range from 50 to 23,000 cfm and up to 5.0 in. wg. AMCA licensed for Air Performance.

Catalog: Centrifugal Backward Inclined (Model SWB)



HVAC Duty Centrifugal Fans

Series 21 fans offer Greenheck's exclusive airtight, Perma-Lock™ seam up through size 49. This feature is less expensive while maintaining the performance of all welded construction. (Sizes 54–73 have all welded housings.)

Single Width: Models BISW/AFSW

Operated in a broad range of fan applications, typically in ducted systems. Versatile construction options allow use in environments which require spark resistance, high temperature tolerance, or resistance to corrosive elements. Capacities range from 100 to 190,000 cfm and up to 15 in. wg. OPTIONS: Spark resistant construction, UL-705 Power Ventilators Listing, UL-762 Grease Listing, UL-Power Ventilators for Smoke Listing

Double Width: Models BIDW/AFDW

Operated in non-ducted inlet applications, primarily handling clean air below 200° F. Higher volume capacities allow for a more compact system design than with single width fans. Capacities range from 1,000 to 350,000 cfm and up to 15 in. wg. OPTIONS: UL-705 Power Ventilators listing

- Air handling quality bearings with L(10) life in excess of 80,000 hours (equivalent to an average life of 400,000 hours)
- A complete three plane vibration test of all fans prior to shipment
- AMCA licensed for Sound and Air Performance

Catalog: Centrifugal Fan Performance Supplement - Double Width

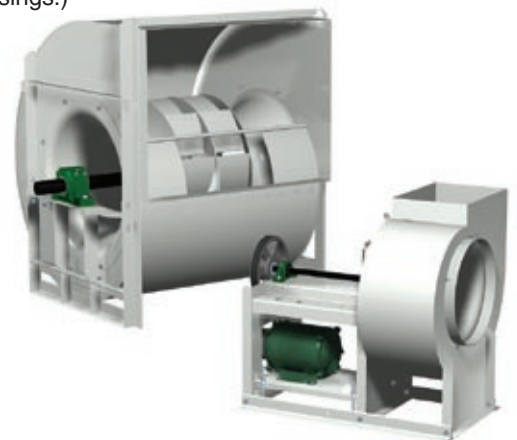

Industrial Duty Centrifugal Fans

The Industrial Duty Centrifugal Fans, Series 41, are designed for heavy duty air movement applications. Series 41 construction includes both backward inclined and airfoil centrifugal wheel fans and features heavy gauge, fully welded steel housings on all sizes. Stainless steel and aluminum construction materials are available for either the entire unit or airstream parts.

Models BISW/AFSW: Single Width

Operated in a broad range of fan applications, typically in ducted systems. Versatile construction options allow use in environments which require spark resistance, high temperature tolerance, or resistance to corrosive elements. Capacities range from 100 to 200,000 cfm and up to 22 in. wg.

Models BIDW/AFDW: Double Width

Operated in non-ducted inlet applications, primarily handling clean air at ambient temperatures. Higher volume capacities allow for a more compact system design than with single width fans. Capacities range from 1,000 to 350,000 cfm and up to 15 in. wg.

- Air handling quality bearings with L(10) life in excess of 80,000 hours (equivalent to an average life of 400,000 hours)
- A complete three plane vibration test of all fans prior to shipment
- AMCA licensed for Sound and Air Performance



Catalog: Series 41 Industrial Duty Centrifugal Fans

Industrial Process Fans

The Industrial Process Fans menu includes fan types engineered and built for reliable operation in harsh environments where high temperatures, high static pressures, and material handling requirements are encountered. AMCA licensed for Air Performance.

Model IPO: Open Radial Material Handling Wheel

Model IPO can be utilized for most industrial requirements. Applications include: exhausting abrasive dust such as grinding and buffing wheel exhaust, conveying granular materials, such as sawdust, wood chips, fume exhaust, and high temperature air handling.



Model IPW: Wool Type Material Handling Wheel

Model IPW is designed for handling long, fibrous, stringy material. Applications include: conveying long wood shavings, yarns, and paper trimmings. It can also be used for most applications of the open wheel with higher efficiencies.



Model IPA: Industrial Air Handling Wheel

Model IPA is designed for clean air exhaust to slight material handling. Applications include: smoke and heat exhaust, corrosives, heavy fumes, and light dust loading. The air handling wheel is the most efficient in the Industrial Process fan series.



Catalog: Industrial Process Fans

Mixed Flow Fans

Mixed Flow fans are an excellent choice for inline ventilation applications. This fan design combines the best axial and centrifugal properties: high fan efficiency, low sound levels, and a smooth, steep fan curve for stable fan selections. Mixed Flow fans can be mounted in any position from horizontal to vertical and their compact design allows for installations in space limited areas.

Model QEI/QEID:

All sizes include the Universal Mounting System for motor position changes in the field. Fans have slip-fit collars for quick and easy connection to ductwork. Typical applications include office buildings, concert halls, parking garages, educational facilities, libraries, and dormitories. AMCA licensed for Sound (inlet and outlet) and Air Performance. Capacities range from 2,000 to 95,000 cfm and up to 8.5 in. wg.

Additional Features:

- Air handling quality bearings with L(10) life in excess of 80,000 hours (equivalent to an average life of 400,000 hours) (QEI)
- Vibration test of complete assembly at the factory prior to shipment

Catalog: Mixed Flow Fans (Model QEI/QEID)



Tubular Centrifugal Fans

Greenheck Tubular Centrifugal Fans, models TCB and TCF, have been designed for commercial and industrial inline or roof upblast applications that demand quiet, efficient and reliable air movement. Tubular centrifugal fans can be mounted in any position from horizontal to vertical providing for installations in the smallest possible space.

Model TCB: Inline Fan, Backward Inclined Wheel

The TCB uses a backward inclined centrifugal wheel for high efficiencies and low sound levels when used in medium pressure ducted systems. All TCB inline fans are belt driven with the motor out of the airstream. Optional construction includes the roof upblast model TCBRU and roof supply model TCBRS. AMCA licensed for Sound and Air Performance.

Catalog: Tubular Centrifugal Fans (Model TCB/TCBRU/TCBRS)



Model TCF: Ducted Inline Fan, Airfoil Wheel

The TCF uses an airfoil centrifugal wheel for high efficiencies and low sound levels in high pressure ducted commercial or industrial systems. Welded steel straightening vanes help to further increase the fans efficiency while straightening the airflow as it leaves the fan housing. Air handling quality bearings with L(10) life in excess of 80,000 hours (equivalent to an average life of 400,000 hours). AMCA licensed for Air Performance.

Catalog: Tubular Centrifugal Fans (Model TCF)

Plenum Fans

Greenheck Plenum Fans are designed for airhandling applications where the fan operates unhoused within a pressurized plenum. Plenum fan model QEP is designed to be compact in size, have the flexibility to supply multiple air take offs and is economically priced.

Model QEP: Belt Drive

QEP plenum fans are designed and engineered for superior performance and reliability. Quiet and efficient operation is achieved through a 12-bladed, airfoil wheel. This design saves energy and improves the overall sound quality by reducing low frequency tones that are difficult to attenuate. The QEP is available in both belt and direct drive and offers numerous accessories to complement your project.

Greenheck's 12-bladed Quiet, Efficient Plenum model QEP will benefit your project by reducing electrical requirements and reducing the sound levels.

Catalog: Plenum Fans (Model QEP)

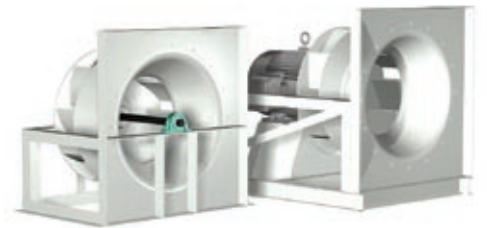

Plug Fans

Greenheck Plug Fans, model PLG, are designed and built to provide reliable service in industrial and commercial applications where the fan operates unhoused within a pressurized plenum.

Model PLG

Unhoused plug fans feature compact unit sizes and high efficiency backward inclined wheels which make them ideal selections for HVAC installations, spray booths, air curtains and high temperature applications including ovens, dryers, and kilns. Air handling quality bearings with L(10) life in excess of 80,000 hours (equivalent to an average life of 400,000 hours).

Catalog: Plug Fans (Model PLG)



Vane Axial Fans

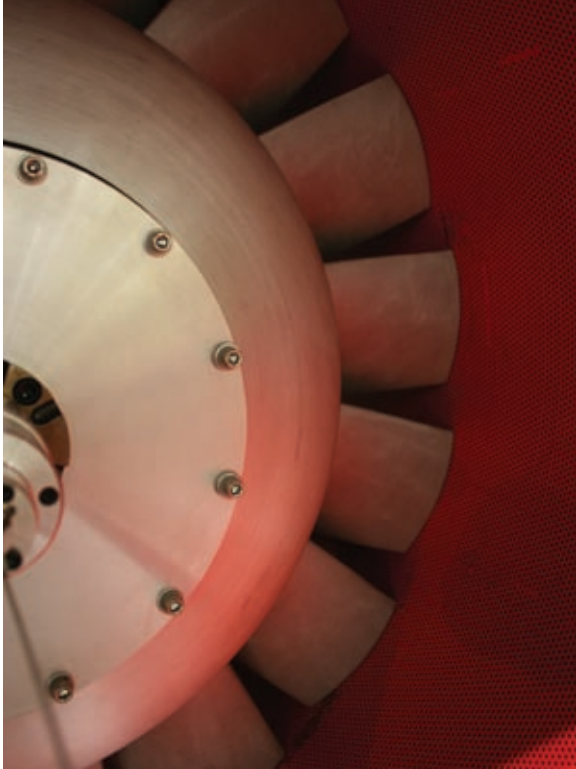

Vane Axial fans are designed for commercial and industrial applications where large volumes of air are required at moderate to high pressures. The tubular design, high efficiency motor and integral straightening vanes provide high performance using minimal space. These fans are an excellent choice for HVAC systems using variable air volumes, clean rooms, parking garage exhaust, and tunnel ventilation. There are a wide variety of vane axial models, arrangements, and configurations. These include belt drive with manually adjustable blade pitch and direct drive with manually adjustable or in-flight controllable blade pitch. All models are available with Greenheck's patented Sound Trap Housing.

Belt Drive

Model VAB

Belt drive vane axial fans accommodate for final system balancing and have manually adjustable blade pitch. These fans are an excellent choice for variable air volume HVAC systems, clean rooms, parking garage exhaust, and tunnel ventilation. For sound critical applications, belt drive vane axial fans are available with Greenheck's patented Sound Trap Housing.

- UL/cUL 705 for electrical is available
- A complete vibration test of all fans prior to shipment
- AMCA licensed for Air Performance

Catalog: *Vane Axial Fans - Belt and Direct Drive*



Direct Drive

Model VAD

Direct Drive - Vane Axial fans are designed for commercial and industrial applications where large volumes of air are required at moderate to high pressures. Direct drive vane axial fans have manually adjustable blade pitch and require minimal maintenance. These fans are an excellent choice for variable air volume HVAC systems, clean rooms, parking garage exhaust, and tunnel ventilation. For sound critical applications, direct drive vane axial fans are available with Greenheck's patented Sound Trap Housing.

- UL/cUL 705 for electrical is available
- A complete vibration test of all fans prior to shipment
- AMCA licensed for Air Performance

Catalog: *Vane Axial Fans - Belt and Direct Drive*



Sound Trap Housing Option - Models VABS & VADS

For sound critical applications, Sound Trap Housings are available on Belt Drive and Direct Drive models. Sound Trap Housings effectively decrease inlet and outlet sound power levels while only slightly increasing fan length and adding no additional pressure drop to the system.

Features

- A perforated steel inner liner directs sound waves into sound absorbing material between the inner liner and solid steel outer shell converting acoustical energy to heat. Two inches of sound absorbing fiberglass is sandwiched between the inner and outer shell. The fiberglass meets requirements of NFPA 90A and 90B, ASTM C 1071 Type I and TIMA Standard AHC-101. The liner meets all requirements for 25 flame spread or 50 smoke development when tested in accordance with ASTM-E84, UL 723 and NFPA-255.
- Steel bands seal the insulated cavity against pressure loss.

Catalog: Vane Axial Fans - Belt and Direct Drive



Medium Pressure Axial Fans

Models TDI/TBI-CA - Inline or Roof Upblast

Axial fans with cast aluminum hub and airfoil blades. Universal Mounting System allows for vertical or horizontal installations. Typical applications involve clean air, fume exhaust, and spark resistant construction. AMCA licensed for Air Performance. Capacities range from 800 to 95,000 cfm and up to 3.25 in. wg.

Catalog: • Tube Axial Inline Fans (Models TDI & TBI-CA Level 3
• Medium Pressure Axial Fans (Model TBI-CA Level 4 & 5)

Models TBI-FS - Inline or Roof Upblast

The TBI-FS has a fabricated steel hub and airfoil blades. It is suitable for continuous high temperature (400° F. / 204° C. max.) for inline configurations, (500° F. max.) for roof upblast configuration and is available with UL Power Ventilators for Smoke Control. The Universal Mounting System accommodates any vertical or horizontal installation configuration. Typical applications involve clean air, industrial processes, and high temperature exhaust. AMCA licensed for Sound and Air Performance. Capacities range from 3,300 to 76,000 cfm for inline configurations (5,500 to 74,000 cfm for roof upblast configurations) up to 3.5 in. wg. Bolt-on straightening vanes are available for increased efficiency.

Catalog: Tube Axial Fan (Model TBI-FS)



Model AX - Inline or Roof Upblast

The AX features a cast aluminum hub and airfoil blades which have manually adjustable blade pitch. Universal Mounting System allows for vertical or horizontal installations. Typical applications include clean air and are available with UL Power Ventilators for Smoke Control and UL-705. AMCA licensed for Air Performance. Capacities range from 500 to 150,000 cfm and up to 5.5 in. wg. Bolt-on straightening vanes (AX-V) are available for increased efficiency.

Catalog: Model AX



Laboratory Exhaust Systems



Greenheck has the most extensive line of laboratory exhaust systems. The main objective of a laboratory exhaust system is to remove hazardous or noxious fumes from a laboratory, dilute the fumes as much as possible and expel them from the lab building preventing contamination of the roof areas and re-entrainment into the building make-up air system. All Vektor™ blowers and bypass air plenums are constructed of heavy gauge, welded steel and coated with baked Hi-Pro Polyester™ resin.

Inline Centrifugal

Vektor-H

Vektor-H models use a tapered outlet nozzle to accelerate the exhaust to a high velocity. This provides the exhaust with additional momentum for displacement high above the roof. Because the Vektor-H is a curb-mounted unit, installation time is reduced by eliminating costly field fabricated inlet and outlet duct. The bypass air plenum and damper accommodates constant and variable volume laboratories. Additionally, the Vektor-H fan and roof curb have been designed to withstand 125 mph windloads without the use of guide wires. Capacities range from 500 to 24,000 cfm and up to 3.5 in. wg. UL-762.

Catalog: Lab Exhaust Systems: Vektor-H High Plume



Inline Mixed Flow

Vektor-MD

Vektor-MD Mixed Flow laboratory exhaust systems use a roof mounted inline blower to exhaust the laboratory space. This design is ideal for applications where roof space is limited, but demands high levels of exhaust at moderate to high external static pressures.

The Vektor-MD utilizes mixed flow impeller technology. The benefits include efficient operation for reduced energy consumption and lower overall sound levels. Vektor-MD bypass air plenums are designed to support single or multiple Vektor-MD inline exhaust blowers in constant or variable volume systems. Capacities range from 1,500 to 80,000 cfm and up to 8 in. wg.

Catalog: Lab Exhaust Systems: Vektor-MD & Vektor-CD



Centrifugal

Vektor-CD

Vektor-CD Centrifugal Blower exhaust systems utilize a roof mounted centrifugal blower to exhaust the laboratory space. This design is ideal for applications requiring horizontal air intake or for systems with external static pressures in excess of 8 in. wg.

The Vektor-CD uses backward curved flat blade and backward curved airfoil blade technology. The benefits include efficient operation for reduced energy consumption and lower overall sound levels. Vektor-CD units are available with AMCA spark C or B construction. Vektor-CD bypass air plenums are designed for single or multiple Vektor centrifugal blowers to exhaust constant or variable volume laboratories. Capacities range from 500 to 100,000 cfm and up to 14 in. wg.



Catalog: Lab Exhaust Systems: Vektor-MD & Vektor-CD

Exhaustive research
yields laboratory **[air]** breakthrough.

Meet the Vektor family!

1. **Vektor-H**
270 cfm - 24,000 cfm
2. **Vektor-MD**
1,500 cfm - 80,000 cfm
3. **Vektor-CD**
500 cfm - 100,000 cfm

Safely discharge fumes from any size lab with a reliable Greenheck lab exhaust system.

Vektor-MD mixed flow inline and Vektor-CD centrifugals use multi-stage nozzles that dilute fumes and discharge them safely, high above pharmaceutical, university, or bio-medical research applications. Vektor-H is ideal for high school labs, hospital isolation rooms and forensic labs. All units can be integrated with the Greenheck Vektor-ERS Energy Recovery System to reduce operating costs. Do some research — visit greenheck.com or contact your Greenheck representative.

All Vektor units meet ANSI Z9.5 and ASHRAE laboratory design guidelines.

715.359.6171 • greenheck.com

Centrifugal & Vane Axial Fans | Fans & Ventilators | Energy Recovery Ventilators | Make-up Air Units | Kitchen Ventilation Systems | Dampers & Louvers | Lab Exhaust Systems

Dampers



Greenheck offers the most UL certified dampers and the largest selection of AMCA-licensed dampers in the industry. Our state-of-the-art testing facility allows us to regularly test our products to ensure quality performance is maintained. With in-house testing capabilities, we are able to accelerate new product development concepts that meet the challenging demands of the ever changing market place. For highly corrosive applications, Greenheck also offers severe environment dampers manufactured with 316 stainless steel (noted in model names as SE).

Curtain Fire Dampers

UL 555 rated models with either galvanized or 304 stainless steel construction. Fire resistance ratings of either 1 1/2 or 3 hours.

Model FD/OFD/FDR: Static Rated

UL 555 rated models for use in HVAC systems that are automatically shut down in the event of a fire emergency. Available in three frame widths: standard, narrowline, and ultra thin; with optional sleeves and transitions.

Catalog: *Dynamic and Static Rated Fire Dampers*

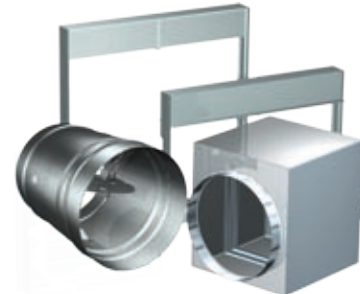

Model DFD/SEDFD/DFDR/SEDFDR/ODFD: Dynamic Rated

UL 555 rated models which will close under airflow, and rated for use in HVAC systems that are operational in the event of a fire emergency. Fire dampers can be mounted either vertically or horizontally with airflow in either direction.

Catalog: *Dynamic and Static Rated Fire Dampers*

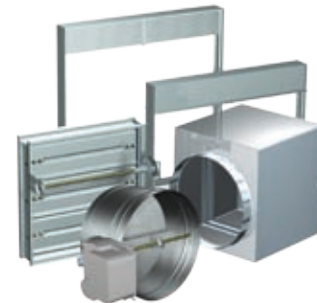

Access Doors

Access doors are designed for use in low to medium pressure duct systems. They provide a durable, practical, and inexpensive means of gaining access to damper components inside the ductwork.

Model HAD: Hinged Style

Model CAD: Cam Style

Model RAD: Round Style

Model PRAD/VRAD: Pressure Relief



Ceiling Radiation Dampers

Models are available in round or rectangular shapes with butterfly type blades or a curtain blade.

Model CRD

All models have been tested and are labeled in accordance with UL 555C, for protection of ceiling openings in fire rated floor/ceiling assemblies with fire resistance ratings of 3 hours or less. In addition, Greenheck CRDs are Warnock Hersey listed for application in gypsum ceilings or ceiling grid systems with fire resistance ratings of up to 3 hours.

Catalog: Dynamic and Static Rated Fire Dampers

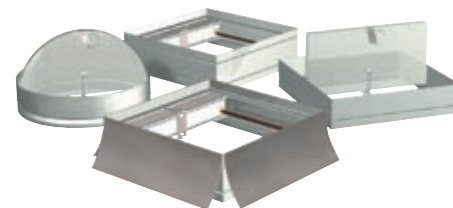

Smoke Dampers

Available in 3V blades for use in systems up to 2000 fpm and 4 in. wg or airfoil blades for use in systems up to 3000 fpm and 6 in. wg. All models have been certified to UL 555S and rated for airflow and leakage in either direction.

Models SMD/SMDR/SESMD/SESMDR

The models are available in leakage class I, II, or III. Galvanized, 304 stainless steel, and 316 stainless steel construction available. Electric and pneumatic actuators.

Catalog: Smoke and Combination Fire Smoke Dampers



Combination Fire Smoke Dampers

Available in 3V blades for use in systems up to 2000 fpm and 4 in. wg or airfoil blades for use in systems up to 3000 fpm and 4 in. wg. All models have been tested and are labeled in accordance with UL 555 and UL 555S. Fire resistance ratings of either 1 1/2 or 3 hours and leakage class ratings of I, II, or III.

Model FSD/FSDR/SEFSD/SEFSDR: Traditional Fire Smoke

Classified to UL 555 and UL 555S and must be mounted within the plane of the wall or floor. Rated for airflow and leakage in either direction. Galvanized, 304 stainless steel, and 316 stainless steel construction available. Electric and pneumatic actuators.

Catalog: Smoke and Combination Fire Smoke Dampers



Model CFSD: Corridor Fire Smoke

Corridor Fire Smoke dampers have three mounting configurations available. One hour Corridor Fire Resistance Rating and UL 555S Leakage Rating. They can be installed horizontally behind grilles and diffusers in corridor penetrations with ratings for airflow and leakage in either direction. Galvanized and 304 stainless steel construction available. Electric and pneumatic actuators.

Catalog: Smoke and Combination Fire Smoke Dampers



Model OFSD: Out Of Wall Fire Smoke

OFSD dampers are classified to UL 555 and UL 555S and can be installed outside of the plane of the wall or floor. This allows the actuator to be mounted internally with convenient access to the damper, actuator, and heat responsive device through the grille. The entire installation can be done from the grille side of the opening. Rated for airflow and leakage in either direction. Electric and pneumatic actuators.

Catalog: Smoke and Combination Fire Smoke Dampers



Marine Dampers

Marine Dampers are United States Coast Guard Class A-60 division approved. The Marine dampers were tested at Underwriters Laboratories (UL) in accordance with International Maritime Organization's (IMO) Fire Test Procedure code. Fire and Combination Fire Smoke Dampers can be used in marine and offshore ventilation systems.

Model IMO/SSIMO

Classified to United States Coast Guard A-60, United States/European Union MRA Listed (ships/wheel) and American Bureau of Shipping (ABS) Approval Design Assessment (ADA).

Catalog: *Marine Products*



Air Measuring Dampers

Air measuring dampers help buildings meet the minimum outdoor air requirements of ASHRAE Standard 62 or California Title 24 by providing accurate monitoring and control of outside air.

Model IAQ:

Air measuring control damper that utilizes patented Speciflow™ Technology monitors airflow, temperature and blade position. IAQ-42 meets IECC (International Energy Conservation Code) requirements with a leakage rating of 3 cfm per sq. foot @ 1 in. wg or less.

Catalog: *Indoor Air Quality (Model IAQ)*



Commercial Control Dampers

Models are available in 3V, extruded airfoil, fabricated airfoil, and round blade designs. Galvanized, aluminum, 304 or 316 stainless steel. Variety of electric two position, modulating and pneumatic actuators.

Model VCD/SEVCD: 3-V Blade Type

Typically used in low to medium pressure and velocity systems. Fabricated blades are reinforced with three longitudinal structurally designed vee's. Available with blade and jamb seals for low leakage applications.

Model VCD/SEVCD: Airfoil Blade Type

Typically used in medium to high pressure and velocity systems. Airfoil blade with structural reinforcement through the entire length. All of these models include blade and jamb seals for low leakage and ultra-low leakage applications.

Model VCDR/VCDRM: Round Blade Type

Typically used in low to medium pressure and velocity systems. Available with blade and jamb seals for low leakage applications. The VCDRM incorporates an insert type multi-blade and the VCDR damper uses a single blade.

Catalog: *HVAC Control Dampers*



Model ICD: Insulated Control Damper

Typically used in applications where it is necessary to minimize the transfer of heat or cold penetration and reduce condensation. ICD-45 features a thermally broken, insulated frame and blade.

Catalog: *Insulated Control Dampers (Model ICD)*

Manual Balancing Dampers

Both round and rectangular single blade construction, as well as multi-blade construction models are available. Designed to regulate the flow of air in an HVAC system. Not intended to be used in applications as a positive shut off or for automatic control.

Models MBD/MBDR

Models come standard with a locking manual quadrant. An optional standoff bracket is available for installations using insulated duct.

Catalog: HVAC Control Dampers



Industrial Control Dampers

Heavy duty flanged style frame dampers with various blade styles and pressure classes. Designed to control airflow and provide shut off in HVAC or industrial process control systems.

Model HCD/SEHCD: Rectangular

Rectangular dampers are available with pressure and velocity capabilities up to 45 in. wg. and 6000 fpm, respectively.

Model HCDR: Round

True round industrial dampers are available for pressure and velocity capabilities up to 20 in. wg and 6500 fpm, respectively.

Model IVDE: Inlet Vane

Typically mounted to the inlet flange of an industrial fan to more efficiently control the amount of airflow entering the fan. Available with manual, electric, or pneumatic actuators. Maximum operating temperature is 200° F.

Catalog: Heavy-Duty/Industrial Dampers



Backdraft Dampers

Designed to allow airflow in one direction and prevent reverse airflow. Models are available with many different mounting orientations, airflow directions, operation types, and performance ratings.

Models WD/ES/EM/HB/BR/HPR/SEBR

Exhaust Dampers

Exhaust backdraft damper models are designed to allow exhaust airflow but prevent airflow in the reverse direction. Typically used with a fan or power roof exhauster. Vertical or horizontal mount.

Intake Dampers

Intake backdraft damper models are designed to allow supply airflow into a building but prevent airflow in the reverse direction. Typically used with a fan or gravity intake ventilator. Vertical or horizontal mount.

Barometric Relief

Barometric relief backdraft dampers have an adjustable start-open pressure for low velocity systems. Typically used for gravity hood ventilation, ductwork outlets, and room or stairwell pressurization.

Pressure Relief

Pressure relief backdraft dampers have an adjustable start-open pressure, which is capable of maintaining pressure at various airflow and closes upon a decrease in differential pressure. Typically used in industrial systems to relieve unexpected overpressure, additional air to a direct fire gas burner or fume exhaust.

Catalog: Heavy-Duty/Industrial Dampers



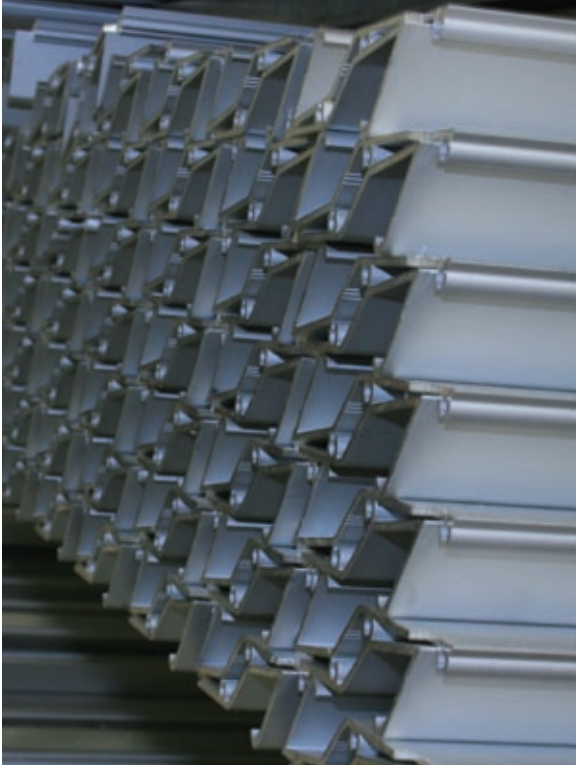

Greenheck offers the most AMCA licensed louvers in the industry. Our experienced sales staff and engineers can configure, design and manufacture a wide range of air control and architectural products to meet your highest standards for both performance and aesthetic appeal. Choose from extruded aluminum or galvanized steel louvers in a variety of designs: stationary, combination, adjustable, sightproof, thinline, wind-driven rain or Florida Product Approved/Miami-Dade qualified. Custom louvered penthouses, sunshades, equipment screens, brick vents and grilles are also available. Most products can be finished as painted or anodized in a variety of standard colors or as a custom color match.

Stationary Extruded Louvers

Available in non-drainable, drainable head, drainable blade, and dual drainable blade models. Blade types of J and K with blade angles of 30 or 45 degrees. AMCA licensed for water penetration and air performance.

Models ESJ/ESK: Non-Drainable

Non-drainable models ESJ and ESK are quite similar, except the K-blade design incorporates an additional offset or "rain hook" to provide extra protection against water penetration. Both models offer a hidden mullion design, for a continuous blade appearance, when multiple sections are necessary. ESJ-401 LT is a low-cost alternative with lighter gauge materials. Frame depths: ESJ - 2, 4, 6; ESK - 4, 6 in.

Models EDJ/EDK/ESID: Drainable Head

EDJ and EDK louvers incorporate a drainable head member, which further improves water penetration protection. Optional 30° blades are also available to maximize free area (EDJ/EDK-430 with 4 in. frame depth). The ESID-430 has both high free area exhaust blades at the top and weather protective intake blades at the bottom, allowing both air discharge and intake ductwork to be hooked up behind the louver while preventing the short cycling of air. Frame depths: EDJ - 2, 4, 6; EDK - 4, 6 in., ESID - 4 in.

Models ESD/EDD/EHM: Drainable Blade

ESD Drainable Blade and EDD Dual Drainable Blade louvers have outstanding resistance to water penetration. Optional 35° blades are also available to maximize free area (ESD-435 and -635 with 4 and 6 in. frame depths). EHM louvers offer a recessed mullion design providing a continuous blade appearance. The ESD-403 LT is a low-cost alternative with lighter gauge materials. Models ESD-435X and ESD-635X are Florida Product Approved. Frame depths: ESD - 2, 4, 6; EDD - 4, 6; EHM - 6 in.

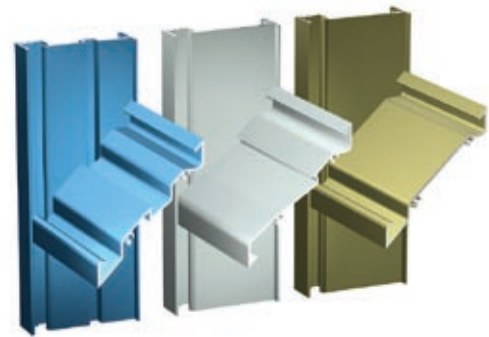

Catalog: Greenheck Louvers (Mechanical Louvers/Architectural Products)

Combination Extruded Louver Dampers

Models combine stationary louver blades and operable damper blades into one common frame member. Damper blades can be closed for tight air shut off. AMCA certified for water penetration and air performance.

Models ECD/EAC/EACN/EACC/EACA: Actuated

Both exposed (ECD) and concealed (EAC, EACC, EACN) linkages are available. Electric, pneumatic, or manual operation. Concealed actuator in the sill member is available (EACC). Airfoil blade available (EACA). Frame depths: ECD, EAC and EACC/EACA - 4, 6 in; EACN - 6 in.

Models GCE/GCI: Gravity

Gravity operation allows airflow in one direction and prevents reverse airflow. GCE is designed for exhaust flow, while GCI is designed for intake. Note: These units must be mounted in direct proximity to an exhaust or intake fan. Frame depths: GCE and GCI - 2, 4 in.

Catalog: *Greenheck Louvers (Mechanical Louvers/Architectural Products)*

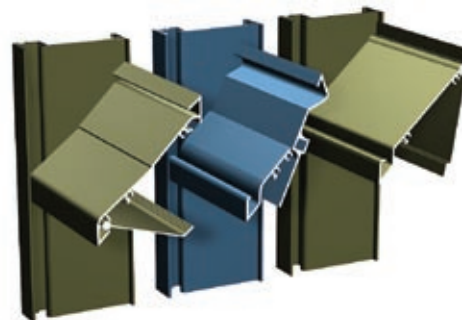

Adjustable Extruded Louvers

Designed to protect air intake and exhaust openings in building exterior walls. Operable blades can be closed for tight air shut-off. AMCA licensed for water penetration and air performance. (Air only for EAH-690 with blade angle at 90°)

Models EAD/EADC: Actuated

EAD and EADC louvers are designed with drainable blades for maximum resistance to water penetration. Typically operated by electric or pneumatic actuators with manual actuators available. Concealed actuator in the sill member is available (EADC). Frame depths: EAD and EADC - 4 and 6 in.

Model EAH: Actuated, Drainable Head

EAH louvers have a drainable head design for increased resistance to water penetration. The EAH-690 has the option of opening either 45° or 90°. Frame depths: EAH-401 - 4 in.; EAH-690 (45° or 90°) - 6 in.

Catalog: *Greenheck Louvers (Mechanical Louvers/Architectural Products)*

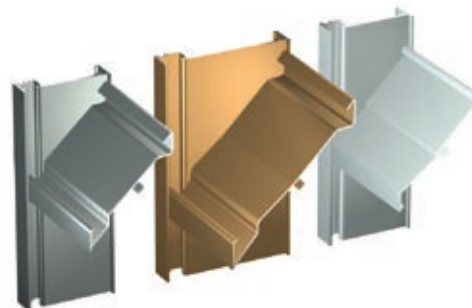

Sightproof Extruded Louvers

Typically used when a visual screen is required. Non-drainable, drainable head, and drainable blade models are available. AMCA licensed for water penetration and air performance.

Model SES: Chevron Blade

Non-drainable sightproof louver. Frame depth: SES - 2, 4 in.

Model SEH: Drainable Head

The drainable head member provides an increased level of resistance to water penetration. Frame depth: SEH - 2, 4 in.

Model SED: Drainable Blade

The drainable blade models are very effective in minimizing water penetration through wall openings. Frame depth: SED - 2, 4, 5 in.

Model SEV: Vertical Blade

Usually installed as a visual screen only. Frame depth: SEV - 4, 5 in.

Catalog: *Greenheck Louvers (Mechanical Louvers/Architectural Products)*

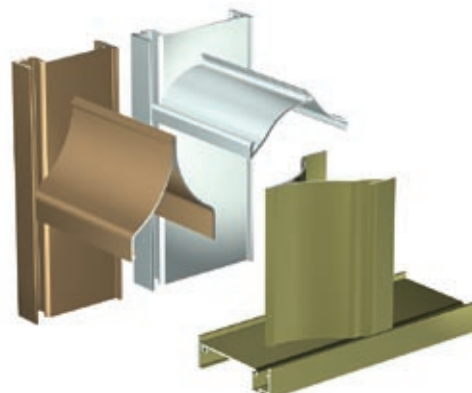

Thinline Extruded Louvers

Commonly used for interior or exterior applications where high free area and low airflow resistance is required.

Models ESU/ESF/ESJ:

The narrow frame depth and various frame options make them ideal products for installation into curtainwalls, windows, door louvers, and as air conditioning grilles. ESU are available in frame or frameless designs and 30° or 50° blade angles. ESF have flat style blades and ESJ has J style blades.

Catalog: Greenheck Louvers (Mechanical Louvers/Architectural Products)



Wind-Driven Rain Louvers

Model EVH are Greenheck's most effective louvers in minimizing water penetration through wall openings. Designed to protect air intake and exhaust openings in building exterior walls that are sensitive to the penetration of wind driven rain. AMCA licensed for water penetration, air performance, and wind driven rain.

Model EVH/EHH:

The design incorporates a drainable head member and vertical (EVH) or horizontal (EHH) rain resistant blades to provide maximum resistance to wind driven rain in even the most stringent AMCA 500L test procedure. Models EHH-501X and EVH-602X are Florida Product Approved. Frame depths: EVH - 2, 4, 6, and 8 in; EHH - 2, 4, 5, 6, and 7 in.

Catalog: Greenheck Louvers (Mechanical Louvers/Architectural Products)



Fabricated Louvers

Typically selected where lowest cost is the primary requirement. Fabricated from galvanized or stainless steel, models are available in both non-drainable and drainable blade designs. AMCA licensed for water penetration and air performance.

Models FSJ/FDS: Stationary Blade

Steel Blade louvers are available in J Style Blade (FSJ) and Drainable Blade designs (FDS). Also available in 304 stainless steel. Frame depths: FSJ and FDS - 4 and 6 in.

Models FAJ/FAD: Adjustable Blade, Actuated

FAJ and FAD Adjustable Blade louvers are fabricated from galvanized steel and provide similar features as the EAD extruded aluminum models and are available with non-drainable (FAJ) and drainable (FAD) blades. Operable blades can be closed for tight air shut off. Typically operated by electric or pneumatic actuators with manual actuators available. Also available in 304 stainless steel and 35° blade angle (FAD).

Frame depths: 4 and 6 in.

Catalog: Greenheck Louvers (Mechanical Louvers/Architectural Products)



Acoustical Fabricated Louvers

Acoustical fabricated models incorporate acoustically insulated blades to provide for sound attenuation to lower infiltrating or escaping noise. Independently tested for sound per applicable ASTM standards AMCA licensed for water penetration and air performance.

Model AFJ: J-Blade

Most economical. Model AFJ-601X is Florida Product Approved. Frame depths: 6, 8, 12 in.

Model AFA: Airfoil Blade

Offers highest free area and lowest airfoil resistance. Frame depth: 8 in.

Model AFS: Sightproof Blade

Offers best sound absorption performance. Frame Depth: 12 in.

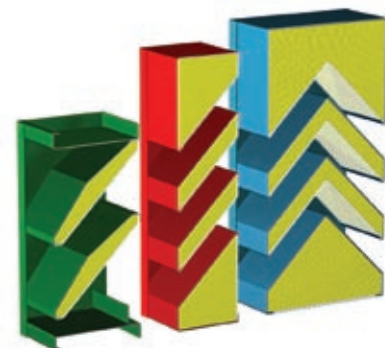

Florida Product Approved/Miami–Dade Louvers

Florida Product Approved louvers are designed to meet the Florida Building Code and should be applied where high wind-load requirements are specified outside of Florida’s High Velocity Hurricane Zone. Miami-Dade Qualified louvers should be applied within Florida’s High Velocity Hurricane Zone or in any location where impact requirements and high wind-load requirements are specified. Additionally, Miami-Dade Wind-Driven Rain (TAS 100A) louvers should be applied where provisions to manage weather are not present.

Model No.	Florida Product Approval No.	Miami-Dade Notice of Acceptance No.	Protocols Applicable
Miami-Dade Qualified Models			
EVH-602D	Pending	06-0711.11	TAS 201, TAS 202, TAS 203, TAS 100A (with VCD-40 damper)
ESS-501D	Pending	05-0912.13	TAS 201, TAS 202, TAS 203
ESD-603D	4826.1	06-0526.02	
SDLE	4825.1	03-0422.05	
ESD-603D/HCD-240	4826.2	06-0526.03	TAS 201, TAS 202, TAS 203, TAS 100A
Florida Product Approved Models			
ESD-435X	6876.3		TAS 202
ESD-635X	6876.4		
EHH-501X	6876.2		
EVH-602X	7494.1		
AFJ-601X	6876.1		



Catalog: *Greenheck Louvers (Mechanical Louvers/Architectural Products)*

Penthouses and Equipment Screens

Equipment screens, exhaust or intake penthouse products are available in extruded aluminum or fabricated steel louver models.

Penthouses/Equipment Screens

Custom designs to meet your application requirements are available. Numerous options for construction features and finishes are also available.

Models WIH/WRH Penthouses: used for gravity intake applications (WIH) or gravity relief/exhaust (WRH) applications.

Model PEV-400: Penthouse Elevator Vent designed to meet elevator shaft ventilation code requirements of the New England states.

Model EES-T200V: Vertical equipment screen with extruded aluminum “T” style blades.

Catalog: *Greenheck Louvers (Mechanical Louvers/Architectural Products)*

Catalog: *Louvered Penthouses (Models WIH/WRH)*



Sunshades and Grilles

Sunshades and grilles can be manufactured in a full line of standard or custom configurations to fulfill both mechanical and/or aesthetic requirements.

Catalog: *Greenheck Louvers (Mechanical Louvers/Architectural Products)*

Catalog: *Architectural Sunshades*



Kitchen Ventilation Systems

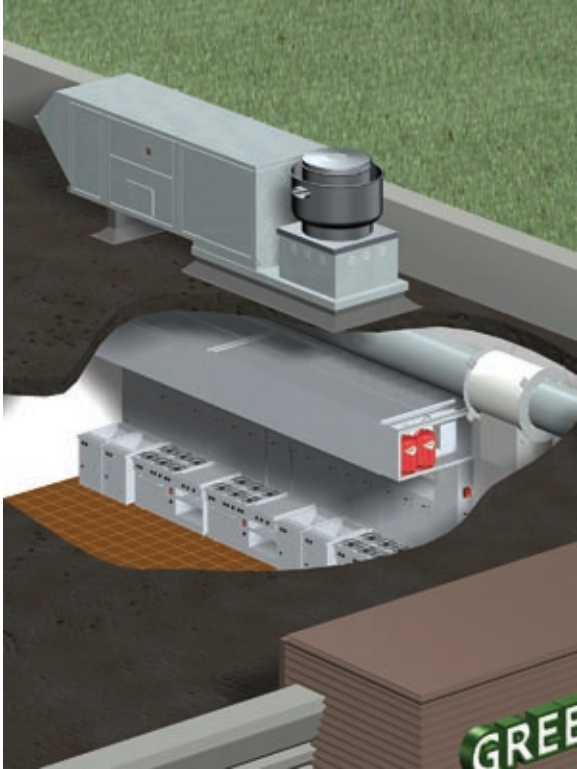

Greenheck offers a wide selection of top quality kitchen hoods, exhaust fans, make-up air units, variable volume systems, fire suppression systems and utility distribution systems. These systems can be designed by using our state-of-the-art Computer Aided Selection Program (CAPS). This program enables you to select and configure products as well as view real-time drawings and create AutoCAD files instantly.

*For detailed information and application of these products visit www.greenheck.com and view the comprehensive Kitchen Ventilation Systems Application & Design Guide. For personalized training and a live kitchen demonstration, talk with your local Greenheck representative to schedule a visit to Greenheck in Schofield, WI.

Type I Kitchen Hoods

Designed for grease laden air. Kitchen Hoods are available in canopy and proximity (backshelf) styles. Canopy hoods are available as exhaust only with external supply options or as integral supply hoods. All hoods are UL/ULc 710 listed and available in single section lengths from 4 to 16 feet. Longer hoods are available in multiple sections with our continuous capture option. Available configurations:

Exhaust Only Hood with External Supply Plenum Options:

BSP - Back Supply

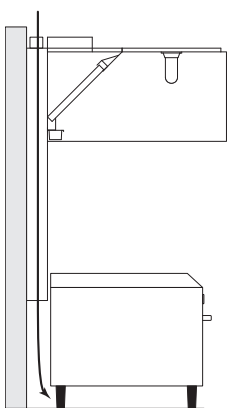

ASP - Air Curtain Supply (14 in. or 24 in.)

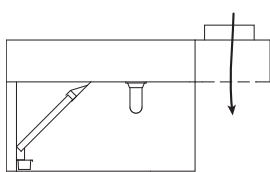

VSP - Variable Supply

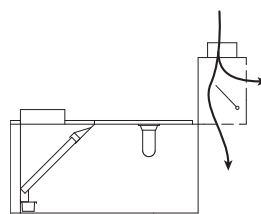

HSP - Horizontal Supply

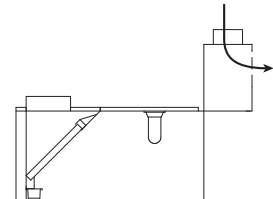

External supply plenums can be mounted on the face of the hood or flush with the ceiling (as shown) for improved performance.

Integral Supply Hoods:

Available in Face Supply or Combination Face and Air Curtain



Filtration Options

Greenheck has the most efficient mechanical grease filters in the industry. All of our grease filters are UL/ULC 1046 classified and NSF certified. Efficiency ratings were obtained by testing to the ASTM F2519-2005 test standard.

Baffle Filter (Model GH): Standard industry baffle (*30% efficient, purchased filter)

Grease-X-Tractor™ (Model GX): High Efficiency centrifugal filter (*60% efficient, Greenheck patented and manufactured filter)

Grease Grabber™ (Model GG): High Efficiency dual filtration system (*90% efficient, Greenheck patented and manufactured filter)

Cartridge Filter (Model GK): (*30% efficient, Greenheck manufactured)

Waterwash Hoods available.

*Filter efficiencies measured at 8 microns.

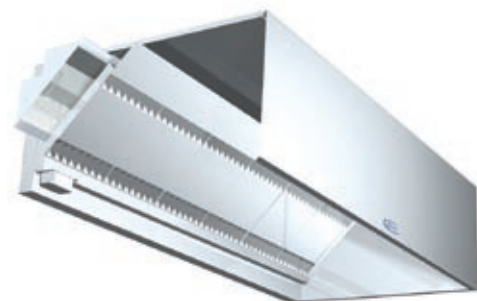

Proximity Hoods

Length from 3 to 16 feet, height from 24 in. to 42 in., width from 23 in. to 36 in. Available with all filter options. Available with flue bypass. The flue bypass option directs hot flue gasses behind the filter bank with the benefit of reducing the radiant heat load in the space and prevents baking grease onto the filters. This option is appliance specific, please contact factory for design assistance. Plate shelf optional.



Specialty Hoods and Options

Features and products designed to meet our customers unique needs.

Model PHEV: This hood is designed for conveyor pizza ovens. The filter banks is rotated perpendicular to the pizza oven to capture effluent from both ends. Exhaust Only.



Round Hoods: Designed for special cooking applications and aesthetics. Available in 5, 6 and 7 foot diameters and up to 36 in. in height.

Industrial Process Hoods: Designed for large volume cooking operations (such as food processing factories). Available with pitched tops for full wash down and special high output lighting. Up to 36 in. in height. Exhaust Only.

Radius Corners and Cladding available for aesthetics.

Type II Kitchen Hoods

Non-filtered heat and condensate hoods. Non-grease applications

Condensate Hoods:

Available with a gutter and drain connection. Baffle options shown below.

Model GD1: No baffles. Most economical and flexible. Lighting options available.

Model GD2: 1 baffle. Designed for moderate condensation applications. Great for vertical door dishwasher applications. Lighting options available.

Model GD3: 2 baffles. Designed for heavy condensate applications.

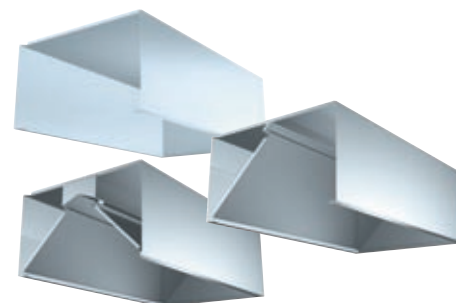

Heat and Fume Hoods:

Model GO: Primarily used for oven applications. Can be used for other heat and fume removal applications. No gutter or drain. Lighting options available.

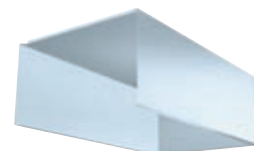

Flex-Connect™ Utility Distribution Systems

Flex-Connect Utility Distribution Systems provide flexibility, convenience and safety in commercial cooking operations. Factory built systems offer a cost effective way to replace contractor built utilities in walls. These systems provide a single point of connection for gas, electricity, water, and steam. Utility Distribution Systems are available in wall and island styles.

Flexible

The Flex-Connect Utility Distribution System allows for future expansion or relocation of appliances without expensive modifications. Gas appliance drops are located every 12 inches, hot and cold water drops every 24 inches to allow for equipment line-up changes. Electrical service can either be point of use breaker or panel board. Receptacles are available as an additional option.

Convenient

Modules are available in incremental lengths, expandable to accommodate virtually any cooking line-up.

Fast

Installation requires only limited trade involvement to bring incoming utility services in for hook-up.

Catalog: Flex-Connect Utility Distribution Systems



Kitchen Fan Control Center

Greenheck's Kitchen Fan Control Center, Model KFCC, is designed to control the exhaust fans, supply fans and lights for the kitchen ventilation system. The KFCC can be interlocked with the fire suppression system.

Fire Suppression Systems

The first line of defense against fire in a commercial kitchen is the hood fire protection system. Greenheck has a variety of factory pre-piped fire protection systems available.

Wet Chemical - Ansul R-102, Ansul Overlapping Coverage, Amerex KP, Amerex Zone Defense

The Ansul R-102 and Amerex KP Wet Chemical, Fire Suppression System is an automatic, pre-engineered system, designed to protect ventilating equipment including hoods, ducts, plenums, filters, and cooking equipment. Once activated, the system discharges Wet Chemical through all nozzles simultaneously.

Amerex Zone Defense and Ansul Overlapping Coverage offers full flood fire protection that allows flexibility in equipment placement.

Catalog: Wet Chemical - Ansul R-102, Amerex KP, Amerex Zone Defense

Dual Agent

The Ansul PIRANHA Restaurant Wet Agent Fire Suppression System is a dual-agent, pre-engineered fixed, automatic fire extinguishing system, designed to protect ventilating equipment including hoods, ducts, plenums, filters, and the cooking equipment. Once activated, the system discharges Wet Chemical followed by water through all nozzles simultaneously.

Catalog: Ansul PIRANHA



Variable Volume

Variable Volume systems automatically control the speed of the exhaust (and make-up air if applicable) fan to ensure optimal hood performance.

Variable Volume

Variable volume kitchen ventilation systems utilize microprocessor controls and operate solely on demand. The system monitors the cooking operation and adjusts the exhaust, supply, and rooftop unit fans so when the cooking load is reduced, the fans operate at a reduced level saving energy. Typically there is a 50% reduction in cost to temper supply air.

Catalog: Variable Volume



Supply Fans and Make Up Air Units

Centrifugal Roof Supply Fans - Models RSF & RSFP

The Centrifugal Roof Supply Fans include filtered and non-filtered belt driven units. These fans are suitable for non-tempered kitchen make-up air or building supply air. These fans feature forward curved wheels for high efficiency and low sound. Housing styles include a straight sided hood (RSF) or a louvered penthouse (RSFP). Capacities range from 650 to 14,300 cfm and up to 2.5 in. wg.

Catalog: *Models RSF/RSFP Forward Curved Centrifugal Roof Supply Fan*

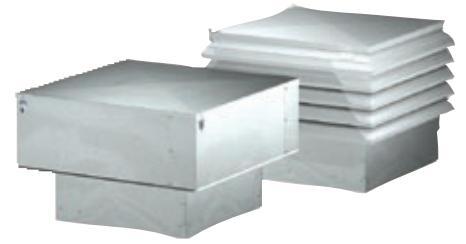

Models KSFB and KSFD

Models KSFB and KSFD economically supply untempered make-up air where needed. Kitchen make-up air applications are common and an extended weatherhood option provides a 10 foot separation between intake and exhaust fan discharge. Airflow volumes range from 800 to 10,500 cfm

Catalog: *Untempered Make-Up Air for Kitchen Systems - Models KSFB and KSFD*

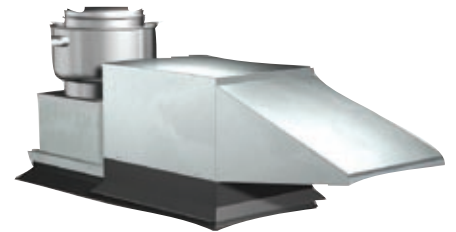

Make-Up Air - Tempered & Untempered

The make-up air products are designed to provide tempered or untempered make-up air as part of a total kitchen ventilation system. The make-up air packages are available with a variety of tempering options for heating and cooling. In addition to basic make-up air operation, recirculation and variable volume airflow options are available on direct gas (Model DGX) and indirect gas (Model IGX). Capacities range from 800 to 24,000 cfm with static pressures up to 2.5 in. wg. See pages 36-38 for more make-up air information.

Heating and cooling options:

- Direct Gas to 24,000 cfm
- Indirect Gas to 15,000 cfm
- Electric to 15,000 cfm
- Steam and Hot Water to 20,000 cfm
- DX and Chilled Water to 11,000 cfm
- Evaporative Cooling to 14,000 cfm

Catalogs: •Direct Gas-Fired (DGK, DG and DGX) •Indirect Gas-Fired (IGX) •Coil Heating (MSX) •No Heat (KSF)



Exhaust Fans

Several different types of Exhaust Fans are utilized in commercial kitchen applications: Centrifugal Upblast and Sidewall Exhaust Fans, Utility Fans, and Inline Fans.

Centrifugal Upblast and Sidewall Exhaust Fans - Series C

The Centrifugal Roof Upblast and Sidewall Exhaust Fans include both direct and belt driven fans with backward inclined centrifugal wheels. These spun aluminum fans are specifically designed for roof mounted or wall mounted applications. Contaminated or grease laden exhaust air can be discharged directly upward, away from the roof surface or discharged out and away from building walls. The fans are suitable for applications such as range hood or fume hood exhaust. The model CUBE is available in 3 pressure ratings: standard, HP (high pressure) and XP (extended pressure). A steel version, USGF, is also available. Capacities range from 80 to 26,000 cfm and up to 5.0 in. wg. UL-762.

Catalogs: •Centrifugal Exhaust Fans (Series C)
•Centrifugal Roof Exhausters (Models G/GB)



Utility Fans - Model SWB

The Utility Fan is belt driven and features a backward inclined centrifugal wheel. This fan is suitable for ducted exhaust, supply, and return-air applications. Typical applications include commercial kitchens and fume hoods. Capacities range from 500 to 23,000 cfm and up to 4.0 in. wg. UL-762.

Catalog: *Centrifugal Backward Inclined (Model SWB)*



Inline Fan, Backward Inclined Wheel - Model TCB

The TCB uses a backward inclined centrifugal wheel for high efficiencies and low sound levels when used in medium pressure ducted systems. All TCB inline fans are belt driven with the motor out of the airstream. Optional construction includes the roof upblast model TCBRU and roof supply model TCBRS. AMCA licensed for Sound and Air Performance. UL-762.

Catalog: *Tubular Centrifugal Fans (Model TCB/TCBRU/TCBRS)*



Energy Recovery Ventilators



With Greenheck, you get a comprehensive energy recovery line ranging from a 300 cfm inline preconditioner to a 20,000 cfm fully tempered ventilator with stand-alone controls delivering space neutral air. Each unit provides fresh outdoor air to your system to meet ASHRAE 62 ventilation requirements, while recovering energy from the exhaust airstream. The enthalpy wheel gives your system the advantage of sensible and latent recovery which improves indoor humidity, maximizes energy savings, and provides lowest first cost air for air conditioning (by reducing outdoor air load). Supplemental cooling and heating options afford you total control over outdoor air conditions entering your system.

Energy Recovery Ventilators

Energy recovery ventilators package a total enthalpy wheel with exhaust and supply blowers and factory pre-wired electrical components. Designs are available for interior and exterior installations. Airflow volumes range from 300 to 20,000 cfm.

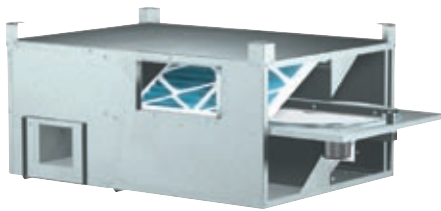

Model MiniVent: Interior Installation

The Minivent is an indoor unit for commercial and institutional applications that require 300 to 800 cfm of ventilation air. The compact design provides an economical solution for individual spaces, such as classrooms and small offices. Pleated 1 inch deep filters, duct flanges, and backdraft dampers are standard.

Catalog: MiniVent Energy Recovery Ventilators



Model ERV: Interior or Exterior Installation

The Model ERV provides complete airflow performance coverage from 500 to 12,000 cfm. Four product arrangements offer installation flexibility for both interior and exterior applications. Available in ten sizes.

Airflow capacity range from 500 to 12,000 cfm

Catalog: ERV Energy Recovery Ventilators



Model APEX

The APEX is designed for applications requiring from 12,000 to 20,000 cfm. It provides centralized outdoor air distribution and reduces the need for multiple installations.

Airflow capacity from 12,000 to 20,000 cfm

Catalog: APEX Energy Recovery Ventilator

Energy Recovery Ventilators with Heating

Combines the benefits of the total enthalpy wheel with supplemental heating. The enthalpy wheel recovers up to 80% of the energy from the exhaust airstream and transfers it to the supply airstream. The tempering section further conditions the outdoor air to desired temperatures.

Model ERH: Interior or Exterior Installation

The Model ERH is designed to provide preconditioned air in the summer and space neutral air in the winter. Ideal for climates with prominent summer and winter seasons. Airflow volumes range from 1,000 to 10,000 cfm.

Heating options: Hot water, indirect gas, and electric heat

Catalog: Energy Recovery Ventilators (Model ERH)

Model APEX

The APEX is designed for applications requiring from 10,000 to 20,000 cfm. It provides centralized outdoor air distribution and reduces the need for multiple installation.

Heating options: Hot water, electric heat

Catalog: APEX Energy Recovery Ventilator

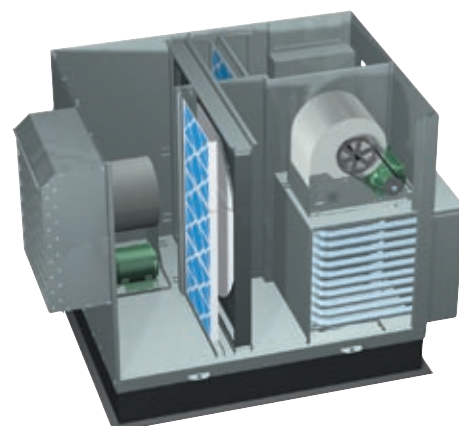

Energy Recovery Ventilators with Cooling and Heating

Combines the benefits of the total energy wheel with supplemental heating and cooling. Fresh outdoor air is preconditioned by the enthalpy wheel, recovering up to 80% of the energy from the exhaust air, while the coil section further conditions the outdoor air to the desired conditions.

Model ERCH

The Model ERCH is designed to process 100% outdoor air to desired supply conditions. Four housing sizes provide airflow capacities from 1,000 to 10,000 cfm.

Cooling options: Chilled water, DX, Packaged DX

Heating options: Hot water, indirect gas, electric heat

Catalog: ERCH Energy Recovery Ventilator with Cooling & Heating

Model ERT

Model ERT features cooling, heating, and a wrap around heatpipe for providing space neutral air with the lowest operating cost. Four housing sizes provide airflow capacities from 1,800 to 10,000 cfm.

Cooling options: Chilled water, DX

Heating options: Hot water, electric heat, and steam

Heat Pipe: Reduces the cooling load and provides free re-heat

Catalog: ERT Energy Recovery Ventilators with Cooling & Heating

Model APEX

The APEX is designed for applications requiring from 10,000 to 20,000 cfm. It provides centralized outdoor air distribution and reduces the need for multiple installations.

Cooling options: Chilled water, DX

Heating options: Hot water, electric heat

Catalog: APEX Energy Recovery Ventilator

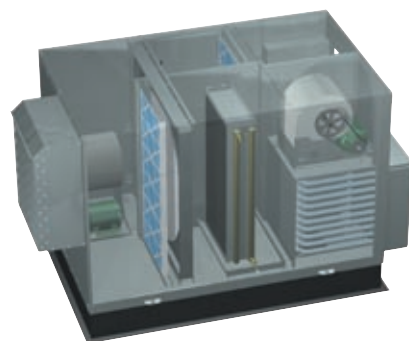



Greenheck offers a wide range of make-up air units for commercial, industrial, and food service applications. Heating options include direct gas-fired, indirect gas-fired, steam, hot water, and electric. Available cooling options are evaporative cooling, direct expansion (DX) coils, and chilled water coils. In addition, GreenHeat™, a high temperature space heating system provides efficient and economical heating for warehouses and other industrial applications.

Direct Gas-Fired Heat

Model DG, TSU, and VSU are designed to provide fresh, direct gas-fired make-up air to commercial and industrial facilities. Model DGK provides make-up air to kitchen facilities. Models DG and DGX may also be applied as GreenHeat™ high temperature space heaters.

Model DGK

Model DGK is designed to be the most simple, compact, and economical solution for kitchen make-up air applications. Airflow volumes range from 800 to 4,500 cfm with heating capacities up to 400,000 BTU/hr.

Catalog: Make-Up Air Units - Model DGK



Model DG

Model DG is designed to be the most economical approach to basic make-up air applications. Airflow volumes range from 800 to 15,000 cfm with heating capacities up to 1,600,000 BTU/hr.

Cooling option: Evaporative cooling up to 12,000 cfm

Catalog: Make-Up Air Units - Model DG

Model DGX

Model DGX has greater capabilities and a modular design for greater configuration flexibility. In addition to basic make-up air operation, filtered recirculation and variable volume airflow options are available. Airflow volumes range from 800 to 48,000 cfm with heating capacities up to 4,800,000 BTU/hr.

Cooling options: Evaporative cooling up to 48,000 cfm
Chilled water or DX cooling up to 11,000 cfm

Catalog: Direct Gas-Fired Heating - Model DGX

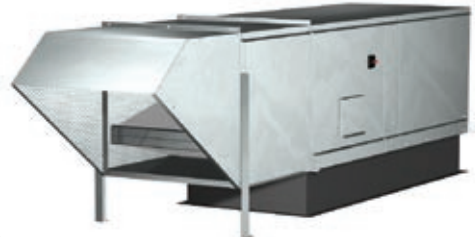

Model TSU

Model TSU offers basic make-up air, recirculation or variable volume airflow options. Airflow volumes range from 20,000 to 64,000 cfm with heating capacities up to 7,000,000 BTU/hr.

Cooling option: Evaporative cooling is available up to 60,000 cfm.

Catalog: Make-Up Air Units - Model TSU

Model VSU

Model VSU offers basic make-up air, recirculation or variable volume airflow options in a vertical unit configuration. Airflow volumes range from 2,000 to 64,000 cfm with heating capacities up to 7,000,000 BTU/hr.

Catalog: Vertical Direct Gas-Fired Make-Up Air Units - Model VSU



Indirect Gas-Fired Heat

Models IG and IGX are designed to provide fresh, indirect gas-fired make-up air to commercial and industrial facilities. Models IG-HV and IGX-HV are specifically designed for providing space heating and ventilation needs.

Model IG

Model IG is ideally suited for gas-fired make-up air applications where a direct gas-fired system is not appropriate. The IG is a single piece housing offering simplicity in an economical design for indoor or outdoor applications. An optional mixing box with controls is available. Airflow volumes range from 800 to 7,000 cfm with heating capacities up to 400,000 BTU/hr (input).

Cooling options: Evaporative cooling up to 7,000 cfm

Catalog: *Indirect Gas-Fired Make-Up Air Units - Model IG*



Model IGX

Model IGX expands on the IG model with a modular design that offers broad configuration flexibility. In addition to basic make-up air operation, recirculation and variable volume airflow options are available. Airflow volumes range from 800 to 15,000 cfm with heating capacities up to 1,200,000 BTU/hr (input).

Cooling options: Evaporative cooling up to 12,000 cfm
Chilled water or DX cooling up to 11,000 cfm

Catalog: *Indirect Gas-Fired Make-Up Air Unit - Model IGX*

Model IG-HV

Model IG-HV provides space heating and cooling, and is also capable of supplying the desired amount of outdoor air for proper ventilation. A filtered mixing box with economizer is standard. Airflow volumes range from 800 to 7,000 cfm with heating capacities up to 400,000 BTU/hr (input).

Catalog: *Indirect Gas-Fired Heating and Ventilating Unit - Model IG-HV*



Model IGX-HV

Model IGX-HV expands on the IG-HV model with a modular design that offers broad configuration flexibility. Airflow volumes range from 800 to 15,000 cfm with heating capacities up to 1,200,000 BTU/hr (input).

Cooling options: Evaporative cooling up to 12,000 cfm
Chilled water or DX cooling up to 11,000 cfm

Catalog: *Indirect Gas-Fired Heating and Ventilating Unit - Model IGX-HV*

Coil Heat or No Heat

Models KSFB, KSFD, and MSX are designed to provide fresh make-up air to commercial and industrial facilities where natural or LP gas is either not available or not desired for heating.

Models KSFB and KSFD

Models KSFB and KSFD economically supply untempered make-up air where needed. Kitchen make-up air applications are common and an extended weatherhood option provides a 10 foot separation between intake and exhaust fan discharge if required to meet NFPA 96. Airflow volumes range from 800 to 10,500 cfm

Catalog: *Untempered Make-Up Air for Kitchen Systems - Model KSFB and KSFD*

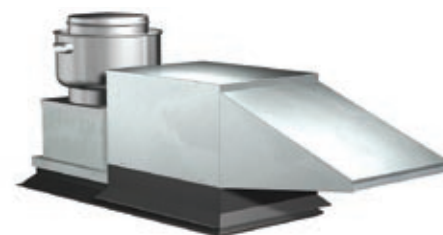

Model MSX

Model MSX is ideally suited for make-up air applications where hot water, steam or electric heat are desired. The MSX has a modular design for broad configuration flexibility. In addition to basic make-up air operation, recirculation and variable volume airflow options are available. Airflow volumes range from 800 to 45,000 cfm.

Heating options: No heat up to 45,000 cfm
Hot water up to 42,000 cfm
Steam up to 42,000 cfm
Electric heat up to 25,000 cfm

Cooling options: Evaporative cooling up to 45,000 cfm
Chilled water or DX cooling up to 11,000 cfm

Catalog: *Modular Supply Unit - Model MSX*



Indoor Air Handlers

Greenheck's Indoor Air Handling Series, models MSCF, LFC, VFC and VFCD, provide air conditioning and/or heating for buildings and specific spaces. The series was designed with low-profile construction to fit within tight spaces in applications such as schools, office buildings, apartments, medical facilities and many other commercial applications. Each model has a variety of sizes and a wide performance range with quiet, trouble free operation.

Model MSCF

Model MSCF is a modular small cabinet fan designed to meet low cost commercial needs for modular design, ultra low profile, easy access, double wall construction, and internal rubber or spring isolation. Designed for schools, medical facilities, office buildings, and many other commercial applications.

Model includes:

- Mixing boxes (with or without filters and dampers)
- Plenums (12 or 24 in.)
- Coils (hot water, steam, chilled water, and direct expansion)
- Filters (2 or 4 in. 30%, 65%, or 95% efficiencies)

Ultra low profile ranging from 11 to 26 inches. Capacities range from 250 to 5,000 cfm and up to 4.5 in. wg.

Catalog: *Indoor Air Handling Units • IAH Series (Model MSCF-FC/MSCF-BI)*



Model LFC

Model LFC provides a low cost method of air conditioning and/or heating a building or specific spaces. These units come standard with a low profile, double wall constructed cabinet designed to fit in tight ceiling spaces. They utilize two types of forward curved wheels providing a wide performance range and quiet operation. Capacities range from 250 to 5,000 cfm and up to 4.0 in. wg.

Catalog: *Indoor Air Handling Units • IAH Series (Model LFC-FC)*



Model VFC

Model VFC provides a low cost method of air conditioning and/or heating for applications requiring a small footprint. These units utilize a steel double wall cabinet construction with hinged motor access. Capacities range from 300 to 4,000 cfm and up to 3.5 in. wg.

Catalog: *Indoor Air Handling Units • IAH Series (Model VFC-FC)*



Model VFCD

Direct Drive Model VFCD provides a low cost method of air conditioning and/or heating for applications requiring a small footprint. These units utilize a steel double wall cabinet construction with hinged motor access. Capacities range from 240 to 4,000 cfm and up to 1.5 in. wg.

Catalog: *Indoor Air Handling Units • IAH Series (Model VFCD-FC)*

Fan Powered Terminals

The UFT fan is designed for underfloor air distribution systems to move cool air and/or provide heat to perimeter zones or interior rooms. The UFT will improve space ventilation, enhance space flexibility, simplify heat load calculations and reduce operational and mechanical equipment cost.

Model UFT

The model UFT is designed for raised floor application and comes in two standard heights of 10 and 13 inches. They are both available with a single or double power pack. Hot water, electric, or no coiled units are available with a control center as standard. Capacities range from 130 to 1,798 cfm and up to .875 in. wg.

Catalog: *Underfloor Fan Terminal (Model UFT)*



Our niche is...

Building Value in...

[air]

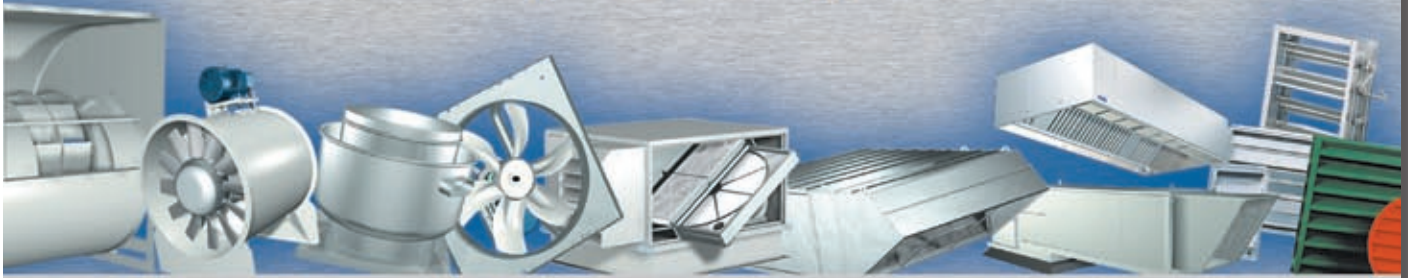

FANS & VENTILATORS:

The world's widest selection means you can give your clients exactly what they need to meet their precise requirements. Greenheck's reputation for reliable performance data and unmatched quality allows you to specify with accuracy, confidence and peace of mind.

CENTRIFUGAL & VANE AXIAL FANS:

Greenheck offers a wide range of AMCA-licensed products for commercial, industrial, and lab ventilation applications. Our reliable products will add value through innovative designs that maximize efficiencies while reducing sound.

ENERGY RECOVERY VENTILATORS:

Improve indoor humidity, meet ASHRAE 62 ventilation requirements and maximize energy savings with a solution that is easy on your first cost budget. Check out our comprehensive line of energy recovery products.

MAKE-UP AIR UNITS:

Choose from the industry's broadest selection of high quality and economical make-up air products for commercial, industrial, food service and warehouse applications. A variety of heating and cooling options are available for your 100% make-up air or recirculation needs.

KITCHEN VENTILATION:

Specify the industry leader in grease extraction technology. Your single source for complete ventilation, fire suppression and utility distribution systems that easily accommodate changes in cooking equipment layout.

DAMPERS & LOUVERS:

Provide proven performance when you specify the widest selection of AMCA-licensed dampers and louvers in the industry. Greenheck offers the most UL-certified dampers. Custom-engineered louvers in any size, any shape, any color.



715.359.6171 • greenheck.com

ANY BUILDING PROJECT — ANY VENTILATION REQUIREMENT — ANYWHERE — ANYTIME



P.O. Box 410 > Schofield, WI 54476-0410 USA
Phone 715-359-6171 > Fax 715-355-2399
greenheck.com

Corporate-All Products Rev. 2 IP January 2007
Copyright © 2007 Greenheck

