

NFPA 921

Guide for Fire and Explosion Investigations

2001 Edition



NFPA, 1 Batterymarch Park, PO Box 9101, Quincy, MA 02269-9101
An International Codes and Standards Organization

NFPA License Agreement

This document is copyrighted by the National Fire Protection Association (NFPA), 1 Batterymarch Park, Quincy, MA 02269-9101 USA.
All rights reserved.

NFPA grants you a license as follows: The right to download an electronic file of this NFPA document for temporary storage on one computer for purposes of viewing and/or printing one copy of the NFPA document for individual use. Neither the electronic file nor the hard copy print may be reproduced in any way. In addition, the electronic file may not be distributed elsewhere over computer networks or otherwise. The hard copy print may only be used personally or distributed to other employees for their internal use within your organization.

IMPORTANT NOTICE ABOUT THIS DOCUMENT

NFPA codes, standards, recommended practices, and guides, of which the document contained herein is one, are developed through a consensus standards development process approved by the American National Standards Institute. This process brings together volunteers representing varied viewpoints and interests to achieve consensus on fire and other safety issues. While the NFPA administers the process and establishes rules to promote fairness in the development of consensus, it does not independently test, evaluate, or verify the accuracy of any information or the soundness of any judgments contained in its codes and standards.

The NFPA disclaims liability for any personal injury, property or other damages of any nature whatsoever, whether special, indirect, consequential or compensatory, directly or indirectly resulting from the publication, use of, or reliance on this document. The NFPA also makes no guaranty or warranty as to the accuracy or completeness of any information published herein.

In issuing and making this document available, the NFPA is not undertaking to render professional or other services for or on behalf of any person or entity. Nor is the NFPA undertaking to perform any duty owed by any person or entity to someone else. Anyone using this document should rely on his or her own independent judgment or, as appropriate, seek the advice of a competent professional in determining the exercise of reasonable care in any given circumstances.

The NFPA has no power, nor does it undertake, to police or enforce compliance with the contents of this document. Nor does the NFPA list, certify, test or inspect products, designs, or installations for compliance with this document. Any certification or other statement of compliance with the requirements of this document shall not be attributable to the NFPA and is solely the responsibility of the certifier or maker of the statement.

See inside back cover for additional important notices and information.

NOTICES

All questions or other communications relating to this document and all requests for information on NFPA procedures governing its codes and standards development process, including information on the procedures for requesting Formal Interpretations, for proposing Tentative Interim Amendments, and for proposing revisions to NFPA documents during regular revision cycles, should be sent to NFPA headquarters, addressed to the attention of the Secretary, Standards Council, National Fire Protection Association, 1 Batterymarch Park, P.O. Box 9101, Quincy, MA 02269-9101.

Users of this document should be aware that this document may be amended from time to time through the issuance of Tentative Interim Amendments, and that an official NFPA document at any point in time consists of the current edition of the document together with any Tentative Interim Amendments then in effect. In order to determine whether this document is the current edition and whether it has been amended through the issuance of Tentative Interim Amendments, consult appropriate NFPA publications such as the *National Fire Codes*[®] Subscription Service, visit the NFPA website at www.nfpa.org, or contact the NFPA at the address listed above.

A statement, written or oral, that is not processed in accordance with Section 6 of the Regulations Governing Committee Projects shall not be considered the official position of NFPA or any of its Committees and shall not be considered to be, nor be relied upon as, a Formal Interpretation.

The NFPA does not take any position with respect to the validity of any patent rights asserted in connection with any items which are mentioned in or are the subject of this document, and the NFPA disclaims liability for the infringement of any patent resulting from the use of or reliance on this document. Users of this document are expressly advised that determination of the validity of any such patent rights, and the risk of infringement of such rights, is entirely their own responsibility.

Users of this document should consult applicable federal, state, and local laws and regulations. NFPA does not, by the publication of this document, intend to urge action that is not in compliance with applicable laws, and this document may not be construed as doing so.

Licensing Policy

This document is copyrighted by the National Fire Protection Association (NFPA). By making this document available for use and adoption by public authorities and others, the NFPA does not waive any rights in copyright to this document.

1. Adoption by Reference—Public authorities and others are urged to reference this document in laws, ordinances, regulations, administrative orders, or similar instruments. Any deletions, additions, and changes desired by the adopting authority must be noted separately. Those using this method are requested to notify the NFPA (Attention: Secretary, Standards Council) in writing of such use. The term "adoption by reference" means the citing of title and publishing information only.

2. Adoption by Transcription—**A.** Public authorities with lawmaking or rule-making powers only, upon written notice to the NFPA (Attention: Secretary, Standards Council), will be granted a royalty-free license to print and republish this document in whole or in part, with changes and additions, if any, noted separately, in laws, ordinances, regulations, administrative orders, or similar instruments having the force of law, provided that: (1) due notice of NFPA's copyright is contained in each law and in each copy thereof; and (2) that such printing and republication is limited to numbers sufficient to satisfy the jurisdiction's lawmaking or rule-making process. **B.** Once this NFPA Code or Standard has been adopted into law, all printings of this document by public authorities with lawmaking or rule-making powers or any other persons desiring to reproduce this document or its contents as adopted by the jurisdiction in whole or in part, in any form, upon written request to NFPA (Attention: Secretary, Standards Council), will be granted a nonexclusive license to print, republish, and vend this document in whole or in part, with changes and additions, if any, noted separately, provided that due notice of NFPA's copyright is contained in each copy. Such license shall be granted only upon agreement to pay NFPA a royalty. This royalty is required to provide funds for the research and development necessary to continue the work of NFPA and its volunteers in continually updating and revising NFPA standards. Under certain circumstances, public authorities with lawmaking or rule-making powers may apply for and may receive a special royalty where the public interest will be served thereby.

3. Scope of License Grant—The terms and conditions set forth above do not extend to the index of this document.

(For further explanation, see the Policy Concerning the Adoption, Printing, and Publication of NFPA Documents, which is available upon request from the NFPA.)

Copyright © 2001 NFPA, All Rights Reserved

NFPA 921

Guide for

Fire and Explosion Investigations

2001 Edition

This edition of NFPA 921, *Guide for Fire and Explosion Investigations*, was prepared by the Technical Committee on Fire Investigations and acted on by the National Fire Protection Association, Inc., at its November Meeting held November 12–15, 2000, in Orlando, FL. It was issued by the Standards Council on January 13, 2001, with an effective date of February 9, 2001, and supersedes all previous editions.

This edition of NFPA 921 was approved as an American National Standard on February 9, 2001.

Origin and Development of NFPA 921

NFPA 921, *Guide for Fire and Explosion Investigations*, was developed by the Technical Committee on Fire Investigations to assist in improving the fire investigation process and the quality of information on fires resulting from the investigative process. The guide is intended for use by both public sector employees who have statutory responsibility for fire investigation and private sector persons conducting investigations for insurance companies or litigation purposes. The goal of the committee is to provide guidance to investigators that is based on accepted scientific principles or scientific research.

The first edition of the document, issued by NFPA in 1992, focused largely on the determination of origin and cause of fires and explosions involving structures. The second edition of the document included revised chapters on the collection and handling of physical evidence, safety, and explosions. NFPA 907M, *Manual for the Determination of Electrical Fire Causes*, was withdrawn as an individual document and was integrated with revisions into this document as a separate chapter. Elements of NFPA 907M that relate to other chapters of this document were relocated appropriately. New chapters dealing with the investigation of motor vehicle fires, management of major investigations, incendiary fires, and appliances were added.

The third edition of the document included a new chapter on fuel gas systems in buildings and the impact of fuel gases on fire and explosion investigations. The chapter on electricity and fire was rewritten to improve organization, clarify terminology, and add references. In the chapter on fire patterns, several sections were revised. Other revisions were made in the chapter on physical evidence on the subject of preservation of the fire scene and of physical evidence. The edition also included new text regarding ignitable liquid detection canine/handler teams.

The fourth edition of this document includes new chapters on building systems, fire-related human behavior, failure analysis and analytical tools, fire and explosion deaths and injuries, and wildfire investigations. An updated chapter on motor vehicle fires has been written. The document has been organized to group chapters into subjects that will make the document more usable.

Technical Committee on Fire Investigations

Daniel L. Churchward, *Chair*
Kodiak Enterprises, Inc., IN [SE]

Richard L. P. Custer, *Secretary*
Custer Powell, Inc., MA [SE]

Craig Beyler, Hughes Assoc., Inc., MD [SE]

Michael R. Bouchard, U.S. Bureau of Alcohol, Tobacco,
and Firearms, MD [E]

Russell K. Chandler, Dept. of Fire Programs, VA [E]

Michael DiMascio, Solutions Engr, Inc., MA [SE]

Richard A. Dyer, Lee's Summit Fire Dept., MO

Rep. Int'l Assn. of Fire Chiefs [E]

Bruce V. Ettling, T F I Services, WA [SE]

Andrew M. Giglio, U.S. Fire Administration, MD [U]

Terry-Dawn Hewitt, McKenna Hewitt, Canada [C]

Ronald L. Hopkins, Eastern Kentucky University, KY [U]

Rep. Int'l Society of Fire Service Instructors

David J. Icove, Tennessee Valley Authority, TN [U]

Carolyn S. Kelly, State of WI, Division of Criminal Investiga-
tion, WI [E]

Rep. Nat'l Assn. of State Fire Marshals

Patrick M. Kennedy, John A. Kennedy & Assoc., IL [SE]

Rep. Nat'l Assn. of Fire Investigators

Michael E. Knowlton, New York State Office of Fire Preven-
tion and Control, NY [E]

Hunter B. Lacy, Royal & Sun Alliance Group, NC [I]

John J. Lentini, Applied Technical Services, Inc., GA [SE]

Jeffrey D. Long, Salt Lake City Fire Dept., UT [U]

Hal C. Lyson, Robins, Kaplan, Miller & Ciresi, MN [C]

James N. Macdonald, Travelers Property Casualty Co.,
CT [I]

Leo Marchand, Insurance Crime Prevention Bureau,
Canada [I]

L. Jeffrey Mattern, FM Global, PA [I]

Willard F. Preston, III, Delaware State Fire Marshal's Of-
fice, DE [E]

Rep. Int'l Fire Marshals Assn.

Anthony D. Putorti, Jr., Nat'l Inst. of Standards and Tech-
nology, MD [RT]

Richard J. Roby, Combustion Science & Engr, Inc.,
MD [SE]

Stuart A. Sklar, Fabian, Sklar & Davis, P.C., MI [C]

David M. Smith, Associated Fire Consultants, AZ

Rep. Int'l Fire Service Training Assn. [M]

Joseph P. Toscano, American Re-Insurance, CT [I]

Rep. Int'l Assn. of Arson Investigators Inc.

Charles R. Watson, S.E.A, Inc., MO [SE]

Alternates

Randall E. Bills, S.E.A., Inc., OH [SE]

(Alt. to C. R. Watson)

Douglas J. Carpenter, Combustion Science & Engr, Inc.,
MD [SE]

(Alt. to R. J. Roby)

David S. Evinger, Robins, Kaplan, Miller & Ciresi, MN [C]

(Alt. to H. C. Lyson)

Michael H. Fabian, Fabian, Sklar & Davis, P.C., MI [C]

(Alt. to S. A. Sklar)

John F. Goetz, Royal & Sun Alliance Group, NC [I]

(Alt. to H. B. Lacy)

Gerald Haynes, U.S. Dept. of the Treasury, DC [E]

(Alt. to M. R. Bouchard)

John Machnicki, Travelers Property Casualty Co., CT [I]

(Alt. to J. N. Macdonald)

Frank E. Florence, NFPA Staff Liaison

Charles F. Mellafont, Insurance Crime Prevention Bureau,
Canada [I]

(Alt. to L. Marchand)

Harold E. Nelson, Hughes Assoc., Inc., VA [SE]

(Alt. to C. Beyler)

Dennis W. Smith, Kodiak Enterprises, Inc., IN [SE]

(Alt. to D. L. Churchward)

William D. Walton, Nat'l Inst. of Standards and Technolo-
gy, MD [RT]

(Alt. to A. D. Putorti)

Larry E. West, West Investigations, PA [I]

(Alt. to J. P. Toscano)

Christopher B. Wood, Custer Powell, Inc., MA [SE]

(Alt. to R. L. P. Custer)

This list represents the membership at the time the Committee was balloted on the final text of this edition. Since that time, changes in the membership may have occurred. A key to classifications is found at the back of the document.

NOTE: Membership on a committee shall not in and of itself constitute an endorsement of the Association or any document developed by the committee on which the member serves.

Committee Scope: This Committee shall have primary responsibility for documents relating to techniques to be used in investigating fires, and equipment and facilities designed to assist or be used in developing or verifying data needed by fire investigators in the determination of the origin and development of hostile fires.

Contents

Chapter 1 Administration	921- 6	5.3 Types of Construction	921- 43
1.1 Scope	921- 6	5.4 Construction Assemblies	921- 46
1.2 Purpose	921- 6	Chapter 6 Electricity and Fire	921- 48
1.3 Definitions	921- 6	6.1 Introduction	921- 48
1.4 Units of Measure	921- 10	6.2 Basic Electricity	921- 48
Chapter 2 Basic Methodology	921- 10	6.3 Building Electrical Systems	921- 51
2.1 Nature of Fire Investigations	921- 10	6.4 Service Equipment	921- 52
2.2 Systematic Approach	921- 10	6.5 Grounding	921- 52
2.3 Relating Fire Investigation to the Scientific Method	921- 10	6.6 Overcurrent Protection	921- 53
2.4 Basic Method of a Fire Investigation	921- 11	6.7 Branch Circuits	921- 57
2.5 Reporting Procedure	921- 11	6.8 Outlets and Devices	921- 58
Chapter 3 Basic Fire Science	921- 12	6.9 Ignition by Electrical Energy	921- 58
3.1 Chemistry of Combustion	921- 12	6.10 Interpreting Damage to Electrical Systems	921- 60
3.2 Heat Transfer	921- 13	6.11 Identification of Arc Melting of Electrical Conductors	921- 65
3.3 Ignition	921- 15	6.12 Static Electricity	921- 66
3.4 Fuel Load	921- 18	Chapter 7 Building Fuel Gas Systems	921- 69
3.5 Fire Development	921- 18	7.1 Introduction	921- 69
3.6 Products of Combustion	921- 23	7.2 Fuel Gases	921- 69
Chapter 4 Fire Patterns	921- 24	7.3 Natural Gas Systems	921- 70
4.1 Introduction	921- 24	7.4 LP-Gas Systems	921- 70
4.2 Dynamics of Pattern Production	921- 24	7.5 Common Fuel Gas System Components	921- 71
4.3 Fire Patterns Defined	921- 26	7.6 Common Piping in Buildings	921- 72
4.4 Types of Fire Patterns	921- 27	7.7 Common Appliance and Equipment Requirements	921- 73
4.5 Surface Effect of Char	921- 27	7.8 Common Fuel Gas Utilization Equipment	921- 73
4.6 Spalling	921- 29	7.9 Investigating Fuel Gas Systems	921- 74
4.7 Oxidation	921- 29	Chapter 8 Fire-Related Human Behavior	921- 76
4.8 Melting of Materials	921- 30	8.1 Introduction	921- 76
4.9 Thermal Expansion and Deformation of Materials	921- 31	8.2 History of Research	921- 76
4.10 Smoke and Soot	921- 31	8.3 General Considerations of Human Responses to Fires	921- 76
4.11 Clean Burn	921- 31	8.4 Factors Related to Fire Initiation	921- 78
4.12 Calcination	921- 32	8.5 Children and Fire	921- 79
4.13 Window Glass	921- 32	8.6 Incendiary Fires	921- 79
4.14 Collapsed Furniture Springs	921- 33	8.7 Human Factors Related to Fire Spread	921- 79
4.15 Location of Objects	921- 33	8.8 Recognition and Response to Fires	921- 79
4.16 Locations of Patterns	921- 34	Chapter 9 Legal Considerations	921- 80
4.17 Pattern Geometry	921- 35	9.1 Introduction	921- 80
4.18 Linear Patterns	921- 39	9.2 Preliminary Legal Considerations	921- 80
4.19 Area Patterns	921- 40	9.3 Evidence	921- 81
4.20 Material Distortion	921- 40	9.4 Criminal Prosecution	921- 83
Chapter 5 Building Systems	921- 41	9.5 Arson-Reporting Statutes	921- 84
5.1 Introduction	921- 41	9.6 Civil Litigation	921- 84
5.2 Features of Design, Construction, and Structural Elements in Evaluating Fire Development	921- 41	9.7 Expert Testimony	921- 85

Chapter 10 Safety	921- 85	15.4 Preliminary Scenario Development	921-118
10.1 General	921- 85	15.5 Detailed Exterior Surface Examination	921-118
10.2 Factors Influencing Scene Safety	921- 86	15.6 Detailed Interior Surface Examination	921-119
10.3 Criminal Acts or Acts of Terrorism	921- 87	15.7 Fire Scene Reconstruction	921-119
Chapter 11 Sources of Information	921- 88	15.8 Fire-Spread Scenario	921-120
11.1 General	921- 88	15.9 Total Burns	921-120
11.2 Legal Considerations	921- 88	Chapter 16 Cause Determination	921-121
11.3 Forms of Information	921- 88	16.1 General	921-121
11.4 Interviews	921- 88	16.2 Classification of the Cause	921-121
11.5 Governmental Sources of Information	921- 89	16.3 Source and Form of Heat of Ignition	921-122
11.6 Private Sources of Information	921- 92	16.4 First Material Ignited	921-122
11.7 Conclusion	921- 93	16.5 Ignition Factor (Cause)	921-123
Chapter 12 Planning the Investigation	921- 93	16.6 Determining Responsibility	921-123
12.1 Introduction	921- 93	16.7 Opinions	921-123
12.2 Basic Incident Information	921- 93	Chapter 17 Failure Analysis	
12.3 Organizing the Investigation Functions	921- 94	and Analytical Tools	921-124
12.4 Preinvestigation Team Meeting	921- 94	17.1 Introduction	921-124
12.5 Specialized Personnel		17.2 Time Lines	921-124
and Technical Consultants	921- 95	17.3 Systems Analysis	921-125
12.6 Case Management	921- 96	17.4 Mathematical Modeling	921-129
Chapter 13 Recording the Scene	921- 96	17.5 Fire Testing	921-130
13.1 Introduction	921- 96	17.6 Data Required for Modeling	
13.2 Photography	921- 96	and Testing	921-130
13.3 Note Taking	921-102	Chapter 18 Explosions	921-131
13.4 Drawings	921-102	18.1 General	921-131
13.5 Architectural and Engineering		18.2 Types of Explosions	921-132
Schedules	921-104	18.3 Characterization of Explosion Damage	921-133
13.6 Specifications	921-106	18.4 Effects of Explosions	921-133
Chapter 14 Physical Evidence	921-106	18.5 Factors Controlling Explosion Effects	921-135
14.1 General	921-106	18.6 Seated Explosions	921-135
14.2 Physical Evidence	921-106	18.7 Nonseated Explosions	921-135
14.3 Preservation of the Fire Scene		18.8 Gas/Vapor Explosions	921-136
and Physical Evidence	921-106	18.9 Dust Explosions	921-138
14.4 Contamination of Physical Evidence	921-108	18.10 Backdraft or Smoke Explosions	921-139
14.5 Methods of Collection	921-108	18.11 Outdoor Vapor Cloud Explosions	921-139
14.6 Evidence Containers	921-111	18.12 Explosives	921-139
14.7 Identification of Physical Evidence	921-112	18.13 Investigating the Explosion Scene	921-140
14.8 Transportation and Storage		18.14 Analyze Origin (Epicenter)	921-145
of Physical Evidence	921-112	18.15 Analyze Fuel Source	921-146
14.9 Chain of Custody of Physical Evidence	921-113	18.16 Analyze Ignition Source	921-146
14.10 Examination and Testing		18.17 Analyze to Establish Cause	921-146
of Physical Evidence	921-113	Chapter 19 Incendiary Fires	921-147
14.11 Evidence Disposition	921-115	19.1 Introduction	921-147
Chapter 15 Origin Determination	921-116	19.2 Incendiary Fire Indicators	921-147
15.1 Introduction	921-116	19.3 Potential Indicators Not Directly	
15.2 Fire Damage Assessment	921-116	Related to Combustion	921-149
15.3 Preliminary Scene Assessment	921-117	19.4 Other Evidentiary Factors	921-150

Chapter 20 Fire and Explosion Deaths and Injuries	921-153	23.7 Fire Cause Determination	921-189
20.1 General	921-153	23.8 Evidence	921-190
20.2 Death Scene Considerations	921-153	23.9 Special Safety Considerations	921-190
20.3 Death-Related Pathological and Toxicological Examination	921-155	23.10 Sources of Information	921-190
20.4 Fundamental Issues of Death Investigations	921-155	Chapter 24 Management of Major Investigations	921-190
20.5 Mechanism of Death	921-156	24.1 Introduction	921-190
20.6 Postmortem Tests and Documentation	921-158	24.2 Understanding between the Parties	921-190
20.7 Fire and Explosion Injuries	921-159	24.3 Agreement between Parties	921-191
20.8 Mechanism of Inhalation Injuries	921-161	24.4 Organization of the Investigation	921-191
Chapter 21 Appliances	921-162	24.5 Team Leader Committee	921-191
21.1 Scope	921-162	24.6 Planning	921-193
21.2 Appliance Scene Recording	921-162	24.7 Occupant Access	921-193
21.3 Origin Analysis Involving Appliances	921-162	24.8 Organization of an Investigation Team	921-193
21.4 Cause Analysis Involving Appliances	921-163	24.9 Regular Meetings	921-193
21.5 Appliance Components	921-163	24.10 Resources	921-193
21.6 Common Residential Appliances	921-168	24.11 Preliminary Information	921-193
Chapter 22 Motor Vehicle Fires	921-170	24.12 Safety	921-193
22.1 Introduction	921-170	24.13 Lighting	921-193
22.2 Vehicle Investigation Safety	921-170	24.14 Access for Investigator	921-193
22.3 Fuels in Vehicle Fires	921-170	24.15 Securing the Scene	921-193
22.4 Ignition Sources	921-172	24.16 Sanitary and Comfort Needs	921-194
22.5 System Identification and Function	921-173	24.17 Communications	921-194
22.6 Body Systems	921-176	24.18 Interviews	921-194
22.7 Recording Motor Vehicle Fire Scenes	921-177	24.19 Plans and Drawings	921-194
22.8 Motor Vehicle Examinations	921-180	24.20 Recording the Scene	921-194
22.9 Total Burns	921-182	24.21 Search Patterns	921-194
22.10 Stolen Vehicles	921-182	24.22 Evidence	921-194
22.11 Vehicles in Structures	921-182	24.23 Release of Information	921-194
22.12 Recreational Vehicles	921-182	24.24 Conducting the Scene Examination	921-194
22.13 Heavy Equipment	921-182	24.25 Preplan for Major Fire Investigations	921-194
Chapter 23 Wildfire Investigations	921-182	Chapter 25 Referenced Publications	921-194
23.1 Introduction	921-182	Appendix A Explanatory Material	921-196
23.2 Wildfire Fuels	921-183	Appendix B Bibliography	921-203
23.3 Factors Affecting Fire Spread	921-184	Appendix C Referenced Publications	921-204
23.4 Indicators	921-186	Index	921-207
23.5 Origin Investigation	921-187		
23.6 Security of the Area or Point of Origin	921-188		

NFPA 921

Guide for

Fire and Explosion Investigations

2001 Edition

NOTICE: An asterisk (*) following the number or letter designating a paragraph indicates that explanatory material on the paragraph can be found in Appendix A.

Changes other than editorial are indicated by a vertical rule in the margin of the pages on which they appear. These lines are included as an aid to the user in identifying changes from the previous edition.

Information on referenced publications can be found in Chapter 25 and Appendix C.

Chapter 1 Administration

1.1 Scope. This document is designed to assist individuals who are charged with the responsibility of investigating and analyzing fire and explosion incidents and rendering opinions as to the origin, cause, responsibility, or prevention of such incidents.

1.2 Purpose. The purpose of this document is to establish guidelines and recommendations for the safe and systematic investigation or analysis of fire and explosion incidents. Fire investigation or analysis and the accurate listing of causes is fundamental to the protection of lives and property from the threat of hostile fire or explosions. It is through an efficient and accurate determination of the cause and responsibility that future fire incidents can be avoided. This document has been developed as a model for the advancement and practice of fire and explosion investigation, fire science, technology, and methodology.

Proper determination of fire origin and cause is also essential for the meaningful compilation of fire statistics. Accurate statistics form part of the basis of fire prevention codes, standards, and training.

This document is designed to produce a systematic, working framework or outline by which effective fire and explosion investigation and origin and cause analysis can be accomplished. It contains specific procedures to assist in the investigation of fires and explosions. These procedures represent the judgment developed from the NFPA consensus process system, that if followed can improve the probability of reaching sound conclusions. Deviations from these procedures, however, are not necessarily wrong or inferior but need to be justified.

The reader should note that frequently the phrase *fire investigation* is used in this document when the context indicates that the relevant text refers to the investigation of both fires and explosions.

As every fire and explosion incident is in some way different and unique from any other, this document is not designed to encompass all the necessary components of a complete investigation or analysis of any one case.

Not every portion of this document may be applicable to every fire or explosion incident. It is up to investigators (depending on their responsibility, as well as the purpose and scope of their investigation) to apply the appropriate recommended procedures in this guide to a particular incident.

In addition, it is recognized that time and resource limitations or existing policies may limit the degree to which the rec-

ommendations in this document will be applied in a given investigation. This document has been developed as a model for the advancement and practice of fire and explosion investigation, fire science, technology, and methodology.

1.3 Definitions.

1.3.1 Accelerant. An agent, often an ignitable liquid, used to initiate a fire or increase the rate of growth or spread of fire.

1.3.2 Accident. An unplanned event that interrupts an activity and sometimes causes injury or damage. A chance occurrence arising from unknown causes; an unexpected happening due to carelessness, ignorance, and the like.

1.3.3 Ambient. Someone's or something's surroundings, especially as they pertain to the local environment, for example, ambient air and ambient temperature.

1.3.4 Ampacity. The current, in amperes (A), that a conductor can carry continuously under the conditions of use without exceeding its temperature rating.

1.3.5 Ampere. The unit of electric current that is equivalent to a flow of one coulomb per second. One coulomb is defined as 6.24×10^{18} electrons.

1.3.6* Approved. Acceptable to the authority having jurisdiction.

1.3.7 Arc. A high-temperature luminous electric discharge across a gap.

1.3.8 Arcing through Char. Arcing associated with a matrix of charred material (e.g., charred conductor insulation) that acts as a semiconductive medium.

1.3.9 Arrow Pattern. A fire pattern displayed on the cross section of a burned wooden structural member.

1.3.10* Arson. The crime of maliciously and intentionally, or recklessly, starting a fire or causing an explosion.

1.3.11 Autoignition Temperature. See 1.3.118.2.

1.3.12 Backdraft. An explosion resulting from the sudden introduction of air (i.e., oxygen) into a confined space containing oxygen-deficient superheated products of incomplete combustion.

1.3.13 Bead. A rounded globule of re-solidified metal at the end of the remains of an electrical conductor that was caused by arcing and is characterized by a sharp line of demarcation between the melted and unmelted conductor surfaces.

1.3.14 Blast Pressure Front. The expanding leading edge of an explosion reaction that separates a major difference in pressure between normal ambient pressure ahead of the front and potentially damaging high pressure at and behind the front.

1.3.15 BLEVE. Boiling liquid expanding vapor explosion.

1.3.16 British Thermal Unit (Btu). The quantity of heat required to raise the temperature of one pound of water 1°F at the pressure of 1 atmosphere and temperature of 60°F. A British thermal unit is equal to 1055 joules, 1.055 kilojoules, and 252.15 calories.

1.3.17 Burning Rate. See 1.3.74, Heat Release Rate.

1.3.18 Calorie. The amount of heat necessary to raise 1 gram of water 1°C at 15°C. A calorie is 4.184 joules and there are 252.15 calories in a British thermal unit (Btu).

1.3.19 Cause. The circumstances, conditions, or agencies that bring together a fuel, ignition source, and oxidizer (such as air or oxygen) resulting in a fire or a combustion explosion.

1.3.20 Ceiling Layer. A buoyant layer of hot gases and smoke produced by a fire in a compartment.

1.3.21 Char. Carbonaceous material that has been burned and has a blackened appearance.

1.3.22 Char Blisters. Convex segments of carbonized material separated by cracks or crevasses that form on the surface of char, forming on materials such as wood as the result of pyrolysis or burning.

1.3.23 Clean Burn. A fire pattern on surfaces where soot has been burned away.

1.3.24* Code. A standard that is an extensive compilation of provisions covering broad subject matter or that is suitable for adoption into law independently of other codes and standards.

1.3.25 Combustible. Capable of burning, generally in air under normal conditions of ambient temperature and pressure, unless otherwise specified. Combustion can occur in cases where an oxidizer other than the oxygen in air is present (e.g., chlorine, fluorine, or chemicals containing oxygen in their structure).

1.3.26* Combustible Gas Indicator. An instrument that samples air and indicates whether there are combustible vapors present.

1.3.27 Combustion Products. Heat, gases, solid particulates, and liquid aerosols produced by burning.

1.3.28 Conduction. Heat transfer to another body or within a body by direct contact.

1.3.29 Convection. Heat transfer by circulation within a medium such as a gas or a liquid.

1.3.30 Current. A flow of electric charge.

1.3.31 Deflagration. A combustion reaction in which the velocity of the reaction front through the unreacted fuel medium is less than the speed of sound.

1.3.32 Detection. (1) Sensing the existence of a fire, especially by a detector from one or more products of the fire, such as smoke, heat, ionized particles, infrared radiation, and the like. (2) The act or process of discovering and locating a fire.

1.3.33 Detonation. A reaction in which the velocity of the reaction front through the unreacted fuel medium is equal to or greater than the speed of sound.

1.3.34 Drop Down. The spread of fire by the dropping or falling of burning materials. Synonymous with "fall down."

1.3.35 Entrainment. The process of air or gases being drawn into a fire, plume, or jet.

1.3.36 Explosion. The sudden conversion of potential energy (chemical or mechanical) into kinetic energy with the production and release of gases under pressure, or the release of gas under pressure. These high-pressure gases then do mechanical work such as moving, changing, or shattering nearby materials.

1.3.36.1 High-Order Explosion. A rapid pressure rise or high-force explosion characterized by a shattering effect on the confining structure or container and long missile distances.

1.3.36.2 Low-Order Explosion. A slow rate of pressure rise or low-force explosion characterized by a pushing or dislodging effect on the confining structure or container and short missile distances.

1.3.36.3 Seat of Explosion. A craterlike indentation created at the point of origin of an explosion.

1.3.36.4 Seated Explosion. An explosion with a highly localized point of origin, such as a crater.

1.3.36.5 Secondary Explosion. Any subsequent explosion resulting from an initial explosion.

1.3.36.6 Smoke Explosion. See 1.3.12, Backdraft.

1.3.37 Explosive. Any chemical compound, mixture, or device that functions by explosion.

1.3.37.1 High Explosive. A material that is capable of sustaining a reaction front that moves through the unreacted material at a speed equal to or greater than that of sound in that medium [typically 3300 ft/sec (1000 m/sec)]; a material capable of sustaining a detonation. (See also Detonation.)

1.3.37.2 Low Explosive. An explosive that has a reaction velocity of less than 3300 ft/s (1000 m/s).

1.3.38 Explosive Material. Any material that can act as fuel for an explosion.

1.3.39 Exposed Surface. The side of a structural assembly or object that is directly exposed to the fire.

1.3.40 Extinguish. To cause to cease burning.

1.3.41 Failure. Distortion, breakage, deterioration, or other fault in an item, component, system, assembly, or structure that results in unsatisfactory performance of the function for which it was designed.

1.3.42 Failure Analysis. A logical, systematic examination of an item, component, assembly, or structure and its place and function within a system, conducted in order to identify and analyze the probability, causes, and consequences of potential and real failures.

1.3.43 Fall Down. See 1.3.34, Drop Down.

1.3.44 Finish Rating. The time in minutes, determined under specific laboratory conditions, at which the stud or joist in contact with the exposed protective membrane in a protected combustible assembly reaches an average temperature rise of 250°F (121°C) or an individual temperature rise of 325°F (163°C) as measured behind the protective membrane nearest the fire on the plane of the wood.

1.3.45 Fire. A rapid oxidation process with the evolution of light and heat in varying intensities.

1.3.45.1 Flash Fire. A fire that spreads rapidly through a diffuse fuel, such as dust, gas, or the vapors of an ignitable liquid, without the production of damaging pressure.

1.3.45.2 Ventilation-Controlled Fire. A fire in which the heat release rate or growth is controlled by the amount of air available to the fire.

1.3.46 Fire Analysis. The process of determining the origin, cause, development, and responsibility as well as the failure analysis of a fire or explosion.

1.3.47 Fire Cause. See 1.3.19, Cause.

1.3.48* Fire Dynamics. The detailed study of how chemistry, fire science, and the engineering disciplines of fluid mechanics and heat transfer interact to influence fire behavior.

1.3.49 Fire Investigation. The process of determining the origin, cause, and development of a fire or explosion.

1.3.50 Fire Propagation. See 1.3.53, Fire Spread.

1.3.51 Fire Scene Reconstruction. The process of recreating the physical scene during fire scene analysis through the removal of debris and the replacement of contents or structural elements in their pre-fire positions.

1.3.52* Fire Science. The body of knowledge concerning the study of fire and related subjects (such as combustion, flame, products of combustion, heat release, heat transfer, fire and explosion chemistry, fire and explosion dynamics, thermodynamics, kinetics, fluid mechanics, fire safety) and their interaction with people, structures, and the environment.

1.3.53 Fire Spread. The movement of fire from one place to another.

1.3.54 Flame. The luminous portion of burning gases or vapors.

1.3.54.1 Premixed Flame. A flame for which the fuel and oxidizer are mixed prior to combustion, as in a laboratory Bunsen burner or a gas cooking range; propagation of the flame is governed by the interaction between flow rate, transport processes, and chemical reaction.

1.3.55 Flame Front. The leading edge of burning gases of a combustion reaction.

1.3.56 Flameover. The condition where unburned fuel (pyrolysate) from the originating fire has accumulated in the ceiling layer to a sufficient concentration (i.e., at or above the lower flammable limit) that it ignites and burns; can occur without ignition and prior to the ignition of other fuels separate from the origin.

1.3.57 Flammable. Capable of burning with a flame.

1.3.58 Flammable Limits. The upper or lower concentration limits at a specified temperature and pressure of a flammable gas or a vapor of an ignitable liquid and air, expressed as a percentage of fuel by volume that can be ignited.

1.3.59 Flammable Range. Concentration range of a flammable gas or a vapor of a flammable liquid in air that can be ignited.

1.3.60 Flashover. A transition phase in the development of a contained fire in which surfaces exposed to thermal radiation reach ignition temperature more or less simultaneously and fire spreads rapidly throughout the space.

1.3.61 Forensic. Legal; pertaining to courts of law.

1.3.62 Fuel. A material that yields heat through combustion.

1.3.62.1 Target Fuel. A fuel that is subject to ignition by thermal radiation such as from a flame or a hot gas layer.

1.3.63 Fuel Gas. Natural gas, manufactured gas, LP-Gas, and similar gases commonly used for commercial or residential purposes such as heating, cooling, or cooking.

1.3.64 Fuel Load. The total quantity of combustible contents of a building, space, or fire area, including interior finish and trim, expressed in heat units or the equivalent weight in wood.

1.3.65 Fuel-Controlled Fire. A fire in which the heat release rate and growth rate are controlled by the characteristics of the fuel, such as quantity and geometry, and in which adequate air for combustion is available.

1.3.66 Gas. The physical state of a substance that has no shape or volume of its own and will expand to take the shape and volume of the container or enclosure it occupies.

1.3.67 Glowing Combustion. Luminous burning of solid material without a visible flame.

1.3.68 Ground Fault. A current that flows outside the normal circuit path, such as (a) through the equipment grounding conductor, (b) through conductive material other than the electrical system ground (metal water or plumbing pipes,

etc.), (c) through a person, or (d) through a combination of these ground return paths.

1.3.69* Guide. A document that is advisory or informative in nature and that contains only nonmandatory provisions. A guide may contain mandatory statements such as when a guide can be used, but the document as a whole is not suitable for adoption into law.

1.3.70 Hazard. Any arrangement of materials and heat sources that presents the potential for harm, such as personal injury or ignition of combustibles.

1.3.71* Heat. A form of energy characterized by vibration of molecules and capable of initiating and supporting chemical changes and changes of state.

1.3.72 Heat Flux. The measure of the rate of heat transfer to a surface, expressed in kilowatts/m², kilojoules/m² · s, or Btu/ft² · s.

1.3.73* Heat of Ignition. The heat energy that brings about ignition.

1.3.74* Heat Release Rate (HRR). The rate at which heat energy is generated by burning.

1.3.75 Ignition. The process of initiating self-sustained combustion.

1.3.75.1 Autoignition. Initiation of combustion by heat but without a spark or flame.

1.3.75.2 Self-Ignition. Ignition resulting from self-heating. Synonymous with spontaneous ignition.

1.3.75.3 Spontaneous Ignition. Initiation of combustion of a material by an internal chemical or biological reaction that has produced sufficient heat to ignite the material.

1.3.76 Ignition Energy. The quantity of heat energy that should be absorbed by a substance to ignite and burn.

1.3.77 Ignition Time. The time between the application of an ignition source to a material and the onset of self-sustained combustion.

1.3.78 Isochar. A line on a diagram connecting points of equal char depth.

1.3.79 Joule. The preferred SI unit of heat, energy or work; there are 4.184 joules in a calorie, and 1055 joules in a British thermal unit (Btu). A watt is a joule/second. (See also 1.3.16, British Thermal Unit, and 1.3.18, Calorie.)

1.3.80 Kilowatt. A measurement of energy release rate.

1.3.81 Liquid.

1.3.81.1 Combustible Liquid. A liquid having a flash point at or above 100°F (37.8°C). (See also Flammable Liquid.)

1.3.81.2 Flammable Liquid. A liquid having a flash point below 100°F (37.8°C) (tag closed cup) and having a vapor pressure not exceeding 40 psia (2068 mm Hg) at 100°F (37.8°C). (See also Combustible Liquid.)

1.3.81.3 Flash Point of a Liquid. The lowest temperature of a liquid, as determined by specific laboratory tests, at which the liquid gives off vapors at a sufficient rate to support a momentary flame across its surface.

1.3.81.4 Ignitable Liquid. Any liquid or the liquid phase of any material that is capable of fueling a fire, including a flammable liquid, combustible liquid, or any other material that can be liquefied and burned.

1.3.82 Material First Ignited. The fuel that is first set on fire by the heat of ignition; to be meaningful, both a type of material and a form of material should be identified.

1.3.83 Noncombustible Material. A material that, in the form in which it is used and under the condition anticipated, will not ignite, burn, support combustion, or release flammable vapors when subjected to fire or heat. Also called *incombustible material* (not preferred).

1.3.84 Nonflammable. (1) Not readily capable of burning with a flame. (2) Not liable to ignite and burn when exposed to flame. Its antonym is *flammable*.

1.3.85 Ohm. The unit of electrical resistance (R), which measures the resistance between two points of a conductor when a constant difference of potential of one volt between these two points produces in this conductor a current of one ampere.

1.3.86 Origin. See 1.3.86.2, Point of Origin, or 1.3.86.1, Area of Origin.

1.3.86.1 Area of Origin. The room or area where a fire began. (See also Point of Origin.)

1.3.86.2 Point of Origin. The exact physical location where a heat source and a fuel come in contact with each other and a fire begins.

1.3.87 Overcurrent. Any current in excess of the rated current of equipment or the ampacity of a conductor; it may result from an overload (see 1.3.88), short circuit, or ground fault.

1.3.88* Overload. Operation of equipment in excess of normal, full-load rating or of a conductor in excess of rated ampacity, which, when it persists for a sufficient length of time, would cause damage or dangerous overheating.

1.3.89 Oxygen Deficiency. Insufficiency of oxygen to support combustion. (See also Ventilation-Controlled Fire.)

1.3.90 Piloted Ignition Temperature. See 1.3.118.4, Ignition Temperature.

1.3.91* Plastic. Any of a wide range of natural or synthetic organic materials of high molecular weight that can be formed by pressure, heat, extrusion, and other methods into desired shapes.

1.3.92 Plume. The column of hot gases, flames, and smoke rising above a fire. Also called *convection column*, *thermal updraft*, or *thermal column*.

1.3.93 Preservation. Application or use of measures to prevent damage, change or alteration, or deterioration.

1.3.94 Products of Combustion. See 1.3.27, Combustion Products.

1.3.95 Proximate Cause. The cause that directly produces the effect without the intervention of any other cause.

1.3.96 Pyrolysis. The chemical decomposition of a compound into one or more other substances by heat alone; pyrolysis often precedes combustion.

1.3.97 Radiant Heat. Heat energy carried by electromagnetic waves longer than light waves and shorter than radio waves; radiant heat (electromagnetic radiation) increases the sensible temperature of any substance capable of absorbing the radiation, especially solid and opaque objects.

1.3.98 Radiation. Heat transfer by way of electromagnetic energy.

1.3.99 Rate of Heat Release. See 1.3.74, Heat Release Rate.

1.3.100* Recommended Practice. A document that is similar in content and structure to a code or standard but that contains only nonmandatory provisions using the word “should” to indicate recommendations in the body of the text.

1.3.101 Rekindle. A return to flaming combustion after apparent but incomplete extinguishment.

1.3.102 Responsibility. The accountability of a person or other entity for the event or sequence of events that caused the fire or explosion, spread of the fire, bodily injuries, loss of life, or property damage.

1.3.103 Risk. (1) The degree of peril; the possible harm that might occur. (2) The statistical probability or quantitative estimate of the frequency or severity of injury or loss.

1.3.104 Rollover. See 1.3.56, Flameover.

1.3.105 Scientific Method. The systematic pursuit of knowledge involving the recognition and formulation of a problem, the collection of data through observation and experiment, and the formulation and testing of a hypothesis.

1.3.106 Self-Heating. The result of exothermic reactions, occurring spontaneously in some materials under certain conditions, whereby heat is liberated at a rate sufficient to raise the temperature of the material.

1.3.107 Short Circuit. An abnormal connection of low resistance between normal circuit conductors where the resistance is normally much greater; this is an overcurrent situation but it is not an overload.

1.3.108 Smoke. An airborne particulate product of incomplete combustion suspended in gases, vapors, or solid and liquid aerosols.

1.3.109 Smoke Condensate. The condensed residue of suspended vapors and liquid products of incomplete combustion.

1.3.110 Smoldering. Combustion without flame, usually with incandescence and smoke.

1.3.111 Soot. Black particles of carbon produced in a flame.

1.3.112 Spalling. Chipping or pitting of concrete or masonry surfaces.

1.3.113 Spark. A small, incandescent particle.

1.3.113.1 Electric Spark. A small, incandescent particle created by some arcs.

1.3.114 Spoliation. Loss, destruction, or material alteration of an object or document that is evidence or potential evidence in a legal proceeding by one who has the responsibility for its preservation.

1.3.115* Spontaneous Heating. Process whereby a material increases in temperature without drawing heat from its surroundings.

1.3.116* Standard. A document, the main text of which contains only mandatory provisions using the word “shall” to indicate requirements and which is in a form generally suitable for mandatory reference by another standard or code or for adoption into law. Nonmandatory provisions shall be located in an appendix, footnote, or fine-print note and are not to be considered a part of the requirements of a standard.

1.3.117 Suppression. The sum of all the work done to extinguish a fire from the time of its discovery.

1.3.118* Temperature. The intensity of sensible heat of a body as measured by a thermometer or similar instrument.

1.3.118.1* Absolute Temperature. A temperature measured in Kelvins (K) or Rankins (R). Absolute zero is the lowest possible temperature, with 0 K being equal to -273°C , and 0 R equal to -460°F ; 273 K corresponds to 0°C , and 460 R corresponds to 0°F .

1.3.118.2 Autoignition Temperature. The lowest temperature at which a combustible material ignites in air without a spark or flame.

1.3.118.3 Effective Fire Temperatures. Identifiable temperatures reached in fires that reflect physical effects that can be defined by specific temperature ranges.

1.3.118.4* Ignition Temperature. Minimum temperature a substance should attain in order to ignite under specific test conditions.

1.3.118.5 Kindling Temperature. See 1.3.118.4, Ignition Temperature.

1.3.118.6 Self-Ignition Temperature. The minimum temperature at which the self-heating properties of a material lead to ignition.

1.3.119 Thermal Column. See 1.3.92, Plume.

1.3.120* Thermal Expansion. The proportional increase in length, volume, or superficial area of a body with rise in temperature.

1.3.121 Thermal Inertia. The properties of a material that characterize its rate of surface temperature rise when exposed to heat; related to the product of the material's thermal conductivity (k), its density (ρ), and its heat capacity (c).

1.3.122 Thermoplastic. Plastic materials that soften and melt under exposure to heat and can reach a flowable state.

1.3.123 Thermoset Plastics. Plastic materials that are hardened into a permanent shape in the manufacturing process and are not commonly subject to softening when heated; typically form char in a fire.

1.3.124 Time Line. Graphic representation of the events in the fire incident displayed in chronological order.

1.3.125 Upper Layer. See 1.3.20, Ceiling Layer.

1.3.126 Vapor. The gas phase of a substance, particularly of those that are normally liquids or solids at ordinary temperatures. (See also Gas.)

1.3.126.1 Vapor Density. The ratio of the average molecular weight of a given volume of gas or vapor to the average molecular weight of an equal volume of air at the same temperature and pressure.

1.3.127 Vector. An arrow used in a fire scene drawing to show the direction of heat, smoke, or flame flow.

1.3.128 Vent. An opening for the passage of, or dissipation of, fluids, such as gases, fumes, smoke, and the like.

1.3.129 Ventilation. (1) Circulation of air in any space by natural wind or convection or by fans blowing air into or exhausting air out of a building. (2) A fire-fighting operation of removing smoke and heat from the structure by opening windows and doors or making holes in the roof.

1.3.130 Venting. The escape of smoke and heat through openings in a building.

1.3.131 Volt (V). The unit of electrical pressure (electromotive force) represented by the symbol "E"; the difference in potential required to make a current of one ampere flow through a resistance of one ohm.

1.3.132 Watt (W). The unit of power, or rate of work. It is equal to one joule per second, or the rate of work represented by a current of one ampere under the potential of one volt.

1.4* Units of Measure. Metric units of measurement in this standard are in accordance with the modernized metric system known as the International System of Units (SI). The unit of liter is outside of but recognized by SI and is commonly used in international fire protection.

1 in. = 2.54 cm

1 ft = 0.3048 m

1 ft² = 0.09290 m²

1 ft³ = 7.481 gal

1 ft³ = 0.02832 m³

1 U.S. gal = 3.785 L

1 lb = 0.4536 kg

1 oz (weight) = 28.35 g

1 ft/s = 0.3048 m/s

1 lb/ft³ = 16.02 kg/m³

1 gpm = 0.06308 L/s

1 atmosphere = pressure exerted by 760 millimeters of mercury of standard density at 0°C , 14.7 lb/in.² (101.3 kPa)

1 Btu/s = 1.055 kW

1 Btu = 1055 J

1 kW = 0.949 Btu/s

1 in. w.c. = 248.8 Pa = 0.036 psi

1 psi = 27.7 in. water column

Chapter 2 Basic Methodology

2.1 Nature of Fire Investigations. A fire or explosion investigation is a complex endeavor involving skill, technology, knowledge, and science. The compilation of factual data, as well as an analysis of those facts, should be accomplished objectively and truthfully. The basic methodology of the fire investigation should rely on the use of a systematic approach and attention to all relevant details. The use of a systematic approach often will uncover new factual data for analysis, which may require previous conclusions to be reevaluated. With few exceptions, the proper methodology for a fire or explosion investigation is to first determine and establish the origin(s), then investigate the cause: circumstances, conditions, or agencies that brought the ignition source, fuel, and oxidant together.

2.2 Systematic Approach. The systematic approach recommended is that of the scientific method, which is used in the physical sciences. This method provides for the organizational and analytical process desirable and necessary in a successful fire investigation.

2.3 Relating Fire Investigation to the Scientific Method. The scientific method (see Figure 2.3) is a principle of inquiry that forms a basis for legitimate scientific and engineering processes, including fire incident investigation. It is applied using the following steps.

FIGURE 2.3 Use of the scientific method.

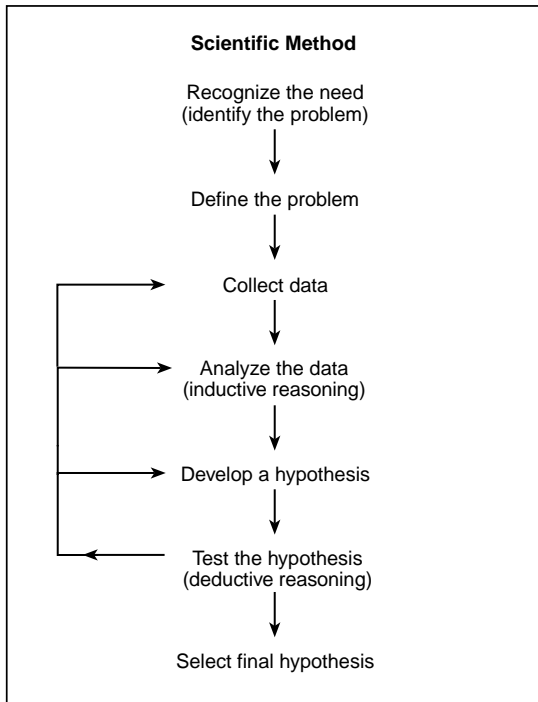

2.3.1 Recognize the Need. First, one should determine that a problem exists. In this case, a fire or explosion has occurred and the cause should be determined and listed so that future, similar incidents can be prevented.

2.3.2 Define the Problem. Having determined that a problem exists, the investigator or analyst should define in what manner the problem can be solved. In this case, a proper origin and cause investigation should be conducted. This is done by an examination of the scene and by a combination of other data collection methods, such as the review of previously conducted investigations of the incident, the interviewing of witnesses or other knowledgeable persons, and the results of scientific testing.

2.3.3 Collect Data. Facts about the fire incident are now collected. This is done by observation, experiment, or other direct data-gathering means. This is called empirical data because it is based on observation or experience and is capable of being verified.

2.3.4 Analyze the Data (Inductive Reasoning). All of the collected and observed information is analyzed by inductive reasoning: the process in which the total body of empirical data collected is carefully examined in the light of the investigator's knowledge, training, and experience. Subjective or speculative information cannot be included in the analysis, only facts that can be proven clearly by observation or experiment.

2.3.5 Develop a Hypothesis. Based on the data analysis, the investigator should now produce a hypothesis or group of hypotheses to explain the origin and cause of the fire or explosion incident. This hypothesis should be based solely on the empirical data that the investigator has collected.

2.3.6 Test the Hypothesis (Deductive Reasoning). The investigator does not have a truly provable hypothesis unless it can stand the test of careful and serious challenge. Testing of the hypothesis is done by the principle of deductive reasoning, in

which the investigator compares his or her hypothesis to all known facts. This testing of the hypothesis may be either cognitive or experimental. If the hypothesis cannot withstand an examination by deductive reasoning, it should be discarded as not provable and a new hypothesis should be tested. This test may include the collection of new data or the reanalysis of existing data. This process needs to be continued until all feasible hypotheses have been tested. Otherwise the fire cause should be listed as "undetermined."

2.3.7 Presumption of Cause. Until data have been collected, no specific hypothesis can be reasonably formed or treated. All fires, however, should be approached by the investigator without presumption.

2.4 Basic Method of a Fire Investigation. Using the scientific method in most fire or explosion incidents should involve the following five major steps from inception through final analysis.

2.4.1 Receiving the Assignment. The investigator should be notified of the incident, what his or her role will be, and what he or she is to accomplish. For example, the investigator should know if he or she is expected to determine the origin, cause, and responsibility; produce a written or oral report; prepare for criminal or civil litigation; make suggestions for code enforcement, code promulgation, or changes; make suggestions to manufacturers, industry associations, or government agency action; or determine some other results.

2.4.2 Preparing for the Investigation. The investigator should marshal his or her forces and resources and plan the conduct of the investigation. Preplanning at this stage can greatly increase the efficiency and therefore the chances for success of the overall investigation. Estimating what tools, equipment, and personnel (both laborers and experts) will be needed can make the initial scene investigation, as well as subsequent investigative examinations and analyses, go more smoothly and be more productive.

2.4.3 Conducting the Investigation. The investigator should conduct an examination of the scene, if it is available, and collect data necessary to the analysis. The actual investigation may take and include different steps and procedures, and these will be determined by the purpose of the investigation assignment. These steps and procedures are described in detail elsewhere in the document. A typical fire or explosion investigation may include all or some of the following: a scene inspection; scene documentation through photography and diagramming; evidence recognition, documentation, and preservation; witness interviews; review and analysis of the investigations of others; and identification and collection of data or information from other appropriate sources.

It is during this phase of the investigation that the data necessary for the analysis of the incident will be collected.

2.4.4 Collecting and Preserving Evidence. Valuable physical evidence should be recognized, properly collected, and preserved for further testing and evaluation or courtroom presentation.

2.4.5 Analyzing the Incident. All collected and available data should be analyzed using the principles of the scientific method. An incident scenario or failure analysis should be described, explaining the origin, cause, fire spread, and responsibility for the incident. Conclusions should be drawn according to the principles expressed in this guide.

2.5 Reporting Procedure. The reporting procedure may take many written or oral forms, depending on the specific responsibility of the investigator. Pertinent information should be reported in a proper form and forum to help prevent recurrence.

Chapter 3 Basic Fire Science

3.1 Chemistry of Combustion. The fire investigator should have a basic understanding of ignition and combustion principles and should be able to use them to help in interpretation of evidence at the fire scene and in the development of conclusions regarding the origin and causes of the fire.

The body of knowledge associated with combustion and fire would easily fill several textbooks. The discussion presented in this section should be considered introductory. The user of this guide is urged to consult the technical literature for additional details.

3.1.1 Fire Tetrahedron. The combustion reaction can be characterized by four components: the fuel, the oxidizing agent, the heat, and the uninhibited chemical chain reaction. These four components have been classically symbolized by a four-sided solid geometric form called a tetrahedron (see Figure 3.1.1). Fires can be prevented or suppressed by controlling or removing one or more of the sides of the tetrahedron.

FIGURE 3.1.1 Fire tetrahedron.

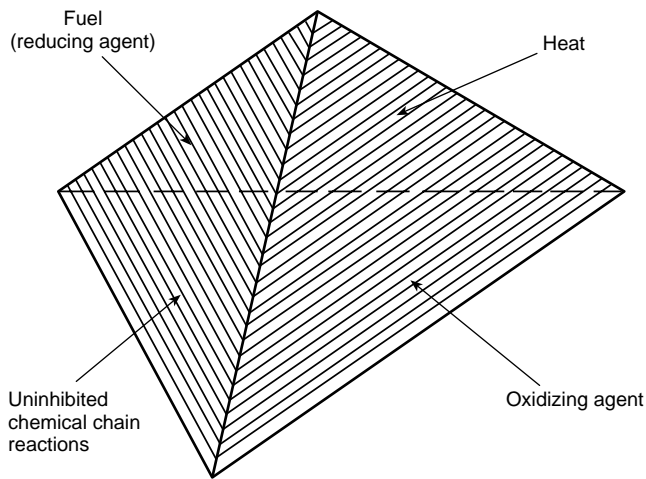

3.1.1.1 Fuel. A fuel is any substance that can undergo combustion. The majority of fuels encountered are organic and contain carbon and combinations of hydrogen and oxygen in varying ratios. In some cases, nitrogen will be present; examples include wood, plastics, gasoline, alcohol, and natural gas. Inorganic fuels contain no carbon and include combustible metals, such as magnesium or sodium. All matter can exist in one of three phases: solid, liquid, or gas. The phase of a given material depends on the temperature and pressure and can change as conditions vary. If cold enough, carbon dioxide, for example, can exist as a solid (dry ice). The normal phase of a material is that which exists at standard conditions of temperature [21°C (70°F)] and pressure [14.7 psi (101.6 kPa) or 1 atmosphere at sea level].

Combustion of a solid or liquid fuel takes place above the fuel surface in a region of vapors created by heating the fuel surface. The heat can come from the ambient conditions, from the presence of an ignition source, or from exposure to an existing fire. The application of heat causes vapors or pyrolysis products to be released into the atmosphere, where they can burn if in the proper mixture with air and if a competent ignition source is present or if the fuel's autoignition temperature is reached. Ignition is discussed in Section 3.3.

Some solid materials can undergo a charring reaction, where oxygen reacts directly with solid material. Charring can be the initial or the final stage of burning. Sometimes charring combustion breaks into flame; on other occasions charring continues through the total course of events.

Gaseous fuels do not require vaporization or pyrolysis before combustion can occur. Only the proper mixture with air and an ignition source are needed.

The form of a solid or liquid fuel is an important factor in its ignition and burning rate. For example, a fine wood dust ignites easier and burns faster than a block of wood. Some flammable liquids, such as diesel oil, are difficult to ignite in a pool but can ignite readily and burn rapidly when in the form of a fine spray or mist.

For the purposes of the following discussion, the term *fuel* is used to describe vapors and gases rather than solids.

3.1.1.2* Oxidizing Agent. In most fire situations, the oxidizing agent is the oxygen in the earth's atmosphere. Fire can occur in the absence of atmospheric oxygen, when fuels are mixed with chemical oxidizers. Many chemical oxidizers contain readily released oxygen. Ammonium nitrate fertilizer (NH_4NO_3), potassium nitrate (KNO_3), and hydrogen peroxide (H_2O_2) are examples.

Normal air contains 21 percent oxygen. In oxygen-enriched atmospheres, such as in areas where medical oxygen is in use or in high-pressure diving or medical chambers, combustion is greatly accelerated. Materials that resist ignition or burn slowly in air can burn vigorously when additional oxygen is present. Combustion can be initiated in atmospheres containing very low percentages of oxygen, depending on the fuel involved. As the temperature of the environment increases, the oxygen requirements are further reduced. While flaming combustion can occur at concentrations as low as 14 to 16 percent oxygen in air at room temperatures of 70°F (21°C), flaming combustion can continue at close to 0 percent oxygen under postflashover temperature conditions. Also, smoldering combustion, once initiated, can continue in a low-oxygen environment even when the surrounding environment is at a relatively low temperature. The hotter the environment, the less oxygen is required. This latter condition is why wood and other materials can continue to be consumed, even though the fire is in a closed compartment with low oxygen content. Fuels that are enveloped in a layer of hot, oxygen-depleted combustion products in the upper portion of a room can also be consumed.

It should be noted that certain gases can form flammable mixtures in atmospheres other than air or oxygen. One example is a mixture of hydrogen and chlorine gas.

For combustion to take place, the fuel vapor or gas and the oxidizer should be mixed in the correct ratio. In the case of solids and liquids, the pyrolysis products or vapors disperse from the fuel surface and mix with the air. As the distance from the fuel source increases, the concentration of the vapors and pyrolysis products decreases. The same process acts to reduce the concentration of a gas as the distance from the source increases.

Fuel burns only when the fuel/air ratio is within certain limits known as the flammable (explosive) limits. In cases where fuels can form flammable mixtures with air, there is a minimum concentration of vapor in air, below which propagation of flame does not occur. This is called the lower flammable limit. There is also a maximum concentration, called the upper flammable limit, above which flame will not propagate.

These limits are generally expressed in terms of percentage by volume of vapor or gas in air.

The flammable limits reported are usually corrected to a temperature of 32°F (0°C) and 1 atmosphere. Increases in temperature and pressure result in reduced lower flammable limits, possibly below 1 percent, and increased upper flammable limits. Upper limits for some fuels can approach 100 percent at high temperatures. A decrease in temperature and pressure will have the opposite effect. Caution should be exercised when using the values for flammability limits found in the literature. The reported values are often based on a single experimental apparatus that does not necessarily account for conditions found in practice.

The range of mixtures between the lower and upper limits is called the flammable (explosive) range. For example, the lower limit of flammability of gasoline at ordinary temperatures and pressures is 1.4 percent, and the upper limit is 7.6 percent. All concentrations by volume falling between 1.4 and 7.6 percent will be in the flammable (explosive) range. All other factors being equal, the wider the flammable range, the greater the likelihood of the mixture coming in contact with an ignition source and thus the greater the hazard of the fuel. Acetylene, with a flammable range between 2.5 and 100 percent, and hydrogen, with a range from 4 to 75 percent, are considered very dangerous and very likely to be ignited when released.

Every fuel-air mixture has an optimum ratio at which point the combustion will be most efficient. This ratio occurs at or near the mixture known by chemists as the stoichiometric ratio. When the amount of air is in balance with the amount of fuel (i.e., after burning there is neither unused fuel nor unused air), the burning is referred to as stoichiometric. This condition rarely occurs in fires except in certain types of gas fires. (See Chapter 18.)

Fires usually have either an excess of air or an excess of fuel. When there is an excess of air, the fire is considered to be fuel controlled. When there is more fuel present than air, a condition that occurs frequently in well-developed room or compartment fires, the fire is considered to be ventilation controlled.

In a fuel-controlled compartment fire, all the burning will take place within the compartment and the products of combustion will be much the same as burning the same material in the open. In a ventilation-controlled compartment fire, the combustion inside the compartment will be incomplete. The burning rate will be limited by the amount of air entering the compartment. This condition will result in unburned fuel and other products of incomplete combustion leaving the compartment and spreading to adjacent spaces. Ventilation-controlled fires can produce massive amounts of carbon monoxide.

If the gases immediately vent out a window or into an area where sufficient oxygen is present, they will ignite and burn when the gases are above their ignition temperatures. If the venting is into an area where the fire has caused the atmosphere to be deficient in oxygen, such as a thick layer of smoke in an adjacent room, it is likely that flame extension in that direction will cease, although the gases can be hot enough to cause charring and extensive heat damage.

3.1.1.3 Heat. The heat component of the tetrahedron represents heat energy above the minimum level necessary to release fuel vapors and cause ignition. Heat is commonly defined in terms of intensity or heating rate (Btu/sec or kilowatts) or as the total heat energy received over time (Btu or kilojoules). In a fire, heat produces fuel vapors, causes ignition, and promotes fire growth and flame spread by maintaining a continuous cycle of fuel production and ignition.

3.1.1.4 Uninhibited Chemical Chain Reaction. Combustion is a complex set of chemical reactions that results in the rapid oxidation of a fuel, producing heat, light, and a variety of chemical by-products. Slow oxidation, such as rust or the yellowing of newspaper, produces heat so slowly that combustion does not occur. Self-sustained combustion occurs when sufficient excess heat from the exothermic reaction radiates back to the fuel to produce vapors and cause ignition in the absence of the original ignition source. For a detailed discussion of ignition, see Section 3.3.

Combustion of solids can occur by two mechanisms: flaming and smoldering. Flaming combustion takes place in the gas or vapor phase of a fuel. With solid and liquid fuels, this combustion is above the surface. Smoldering is a surface-burning phenomenon with solid fuels and involves a lower rate of heat release and no visible flame. Smoldering fires frequently make a transition to flaming after sufficient total energy has been produced, or when airflow is present to speed up the combustion rate.

3.2 Heat Transfer. The transfer of heat is a major factor in fires and has an effect on ignition, growth, spread, decay (reduction in energy output), and extinction. Heat transfer is also responsible for much of the physical evidence used by investigators who attempt to establish a fire's origin and cause.

It is important to distinguish between heat and temperature. Temperature is a measure that expresses the degree of molecular activity of a material compared to a reference point, such as the freezing point of water. Heat is the energy that is needed to maintain or change the temperature of an object. When heat energy is transferred to an object, the temperature increases. When heat is transferred away, the temperature decreases.

Heat is always transferred from the high-temperature mass to the low-temperature mass. Heat transfer is measured in terms of energy flow per unit of time (Btu/sec or kilowatts). The greater the temperature difference between the objects, the more energy is transferred per unit of time and the higher the heat transfer rate is. Temperature can be compared to the pressure in a fire hose and heat or energy transfer to the water flow in gallons per minute.

Heat transfer is accomplished by three mechanisms: conduction, convection, and radiation. All three play a role in the investigation of a fire, and an understanding of each is necessary.

3.2.1 Conduction. Conduction is the form of heat transfer that takes place within solids when one portion of an object is heated. Energy is transferred from the heated area to the unheated area at a rate dependent on the difference in temperature and the physical properties of the material. The properties are the thermal conductivity (k), the density (ρ), and the heat capacity (c). The heat capacity (specific heat) of a material is a measure of the amount of heat necessary to raise the temperature of a unit mass 1 degree, under specified conditions (J/kg-K, Btu/lb-°F).

If thermal conductivity (k) is high, the rate of heat transfer through the material is high. Metals have high thermal conductivities (k), while plastics or glass have low thermal conductivity (k) values. Other properties (k and c) being equal, high-density (ρ) materials conduct heat faster than low-density materials. This is why low-density materials make good insulators. Similarly, materials with a high heat capacity (c) require more energy to raise the temperature than materials with low heat capacity values.

Generally, conduction heat transfer is considered to occur between two points, with the energy source at a constant temperature. The other point will increase to some steady temperature

lower than that of the source. This condition is known as steady state. Once steady state is reached, thermal conductivity (k) is the dominant heat transfer property. In the growing stages of a fire, temperatures are continuously changing, resulting in changing rates of heat transfer. During this period, all three properties — thermal conductivity (k), density (ρ), and heat capacity (c) — play a role. Taken together, these properties are commonly called the thermal inertia of a material and are expressed in terms of k , ρ , c . Table 3.2.1 provides data for some common materials.

Table 3.2.1 Thermal Properties of Selected Materials

Material	Thermal Conductivity (k) (W/m-K)	Density (ρ) (kg/m ³)	Heat Capacity (c_p) (J/kg-K)
Copper	387	8940	380
Concrete	0.8–1.4	1900–2300	880
Gypsum plaster	0.48	1440	840
Oak	0.17	800	2380
Pine (yellow)	0.14	640	2850
Polyethylene	0.35	940	1900
Polystyrene (rigid)	0.11	1100	1200
Polyvinylchloride	0.16	1400	1050
Polyurethane*	0.034	20	1400

*Typical values, properties vary.

Source: Drysdale, *An Introduction to Fire Dynamics*, p. 36.

The impact of the thermal inertia on the rise in temperature in a space or on the material in it is not constant through the duration of a fire. Eventually, as the materials involved reach a constant temperature, the effects of density (ρ) and heat capacity (c) become insignificant relative to thermal conductivity. Therefore, thermal inertia of a material is most important at the initiation and early stages of a fire (preflashover).

Conduction of heat into a material as it affects its surface temperature is an important aspect of ignition. Thermal inertia is an important factor in how fast the surface temperature will rise. The lower the thermal inertia of the material, the faster the surface temperature will rise. Conduction is also a mechanism of fire spread. Heat conducted through a metal wall or along a pipe or metal beam can cause ignition of combustibles in contact with the heated metals. Conduction through metal fasteners such as nails, nail plates, or bolts can result in fire spread or structural failure.

3.2.2 Convection. Convection is the transfer of heat energy by the movement of heated liquids or gases from the source of heat to a cooler part of the environment.

Heat is transferred by convection to a solid when hot gases pass over cooler surfaces. The rate of heat transfer to the solid is a function of the temperature difference, the surface area exposed to the hot gas, and the velocity of the hot gas. The higher the velocity of the gas, the greater the rate of convective transfer. Flame contact involves heat transfer by convection.

In the early history of a fire, convection plays a major role in moving the hot gases from the fire to the upper portions of the room of origin and throughout the building. As the room temperatures rise with the approach of flashover, convection continues, but the role of radiation increases rapidly and

becomes the dominant heat transfer mechanism. See 3.5.3.2 for a discussion of the development of flashover. Even after flashover, convection can be an important mechanism in the spread of smoke, hot gases, and unburned fuels throughout a building. This can spread the fire or toxic or damaging products of combustion to remote areas.

3.2.3 Radiation. Radiation is the transfer of heat energy from a hot surface to a cooler surface by electromagnetic waves without an intervening medium. For example, the heat energy from the sun is radiated to earth through the vacuum of space. Radiant energy can be transferred only by line of sight and will be reduced or blocked by intervening materials. Intervening materials do not necessarily block all radiant heat. For example, radiant heat is reduced on the order of 50 percent by some glazing materials.

The rate of radiant heat transfer is strongly related to a difference in the fourth power of the absolute temperature of the radiator and the target. At high temperatures, small increases in the temperature difference result in a massive increase in the radiant energy transfer. Doubling the absolute temperature of the hotter item without changing the temperature of the colder item results in a 16-fold increase in radiation between the two objects. Figure 3.2.3 illustrates this relation.

FIGURE 3.2.3 Relation of radiation to temperature.

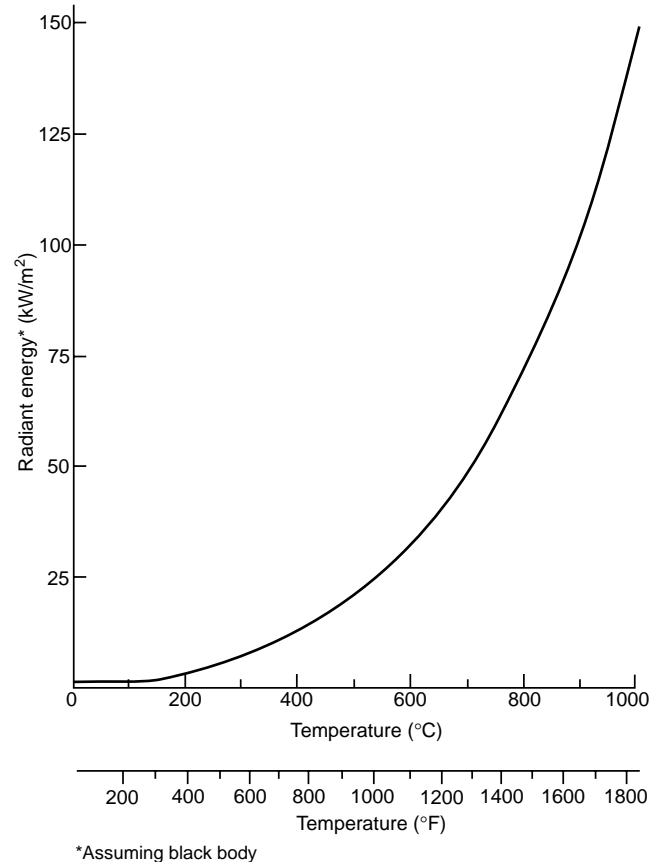

The rate of heat transfer is also strongly affected by the distance between the radiator and the target. As the distance increases, the amount of energy falling on a unit of area falls off in a manner that is related to both the size of the radiating source and the distance to the target.

3.3* Ignition. In order for most materials to be ignited, they should be in a gaseous or vapor state. A few materials may burn directly in a solid state or glowing form of combustion including some forms of carbon and magnesium. These gases or vapors should then be present in the atmosphere in sufficient quantity to form a flammable mixture. Liquids with flash points below ambient temperatures do not require additional heat to produce a flammable mixture. The fuel vapors produced should then be raised to their ignition temperature. The time and energy required for ignition to occur is a function of the energy of the ignition source, the thermal inertia (k, ρ, c) of the fuel, and the minimum ignition energy required by that fuel and the geometry of the fuel. If the fuel is to increase in temperature, the rate of heat transfer to the fuel must be greater than the sum of the conduction losses, convection losses, radiation losses, energy associated with phase changes (such as the heat of vaporization), and energy associated with chemical changes (such as pyrolysis). In some cases, chemical changes in the fuel during heating may also produce heat prior to combustion (exothermic reaction). If the fuel is to reach its ignition temperature, the heat source itself must have a temperature higher than the fuel's ignition temperature. Spontaneous ignition is an exception.

Table 3.3 shows the temperature of selected ignition sources. A few materials, such as cigarettes, upholstered furniture, sawdust, and cellulosic insulation, are permeable and readily allow air infiltration. These materials can burn as solid phase combustion, known as smoldering. This is a flameless form of combustion whose principal heat source is char oxidation. Smoldering is hazardous, as it produces more toxic compounds than flaming combustion per unit mass burned, and it provides a chance for flaming combustion from a heat source too weak to produce flame directly.

The term *smoldering* is sometimes inappropriately used to describe a nonflaming response of a solid fuel to an external heat flux. Solid fuels, such as wood, when subjected to a sufficient heat flux, will degrade, gasify, and release vapors. There usually is little or no oxidation involved in this gasification process, and thus it is endothermic. This is more appropriately referred to as forced pyrolysis, and not smoldering.

3.3.1 Ignition of Solid Fuels. For solid fuels to burn with a flame, the substance should either be melted and vaporized (like thermoplastics) or be pyrolyzed into gases or vapors (i.e., wood or thermoset plastic). In both examples, heat must be supplied to the fuel to generate the vapors.

High-density materials of the same generic type (woods, plastics) conduct energy away from the area of the ignition source more rapidly than low-density materials, which act as insulators and allow the energy to remain at the surface. For example, given the same ignition source, oak takes longer to ignite than a soft pine. Low-density foam plastic, on the other hand, ignites more quickly than high-density plastic.

The amount of surface area for a given mass (surface area to mass ratio) also affects the quantity of energy necessary for ignition. It is relatively easy to ignite one pound of thin pine shavings with a match, while ignition of a one-pound solid block of wood with the same match is very unlikely.

Because of the higher surface area to mass ratio, corners of combustible materials are more easily burned than flat surfaces. Table 3.3.1 shows the time for pilot ignition of wood exposed to varying temperatures.

Table 3.3 Reported Burning and Sparking Temperatures of Selected Ignition Sources

Source	Temperature	
	°F	°C
Flames		
Benzene ^a	1690	920
Gasoline ^a	1879	1026
JP-4 ^b	1700	927
Kerosene ^a	1814	990
Methanol ^a	2190	1200
Wood ^c	1880	1027
Embers^d		
Cigarette (puffing)	1520-1670	830-910
Cigarette (free burn)	930-1300	500-700
Mechanical sparks^e		
Steel tool	2550	1400
Copper-nickel alloy	570	300

^aFrom Drysdale, *An Introduction to Fire Dynamics*.
^bFrom Hagglund and Persson, *The Heat Radiation from Petroleum Fires*.
^cFrom Hagglund and Persson, *An Experimental Study of the Radiation from Wood Flames*.
^dFrom Krasny, *Cigarette Ignition of Soft Furnishings — A Literature Review with Commentary*.
^eFrom NFPA *Fire Protection Handbook*, 15th ed., pp. 4-167.

Table 3.3.1 Time Required to Ignite Wood Specimens

Wood 1 1/4 in. × 1 1/4 in. × 4 in. (32 mm × 32 mm × 102 mm)	No Ignition in 40 Min		Exposure Before Ignition, by Pilot Flame, Minutes						
	°F	°C	356°F (180°C)	392°F (200°C)	437°F (225°C)	482°F (250°C)	572°F (300°C)	662°F (350°C)	752°F (400°C)
Long leaf pine	315	157	14.3	11.8	8.7	6.0	2.3	1.4	0.5
Red oak	315	157	20.0	13.3	8.1	4.7	1.6	1.2	0.5
Tamarack	334	167	29.9	14.5	9.0	6.0	2.3	0.8	0.5
Western larch	315	157	30.8	25.0	17.0	9.5	3.5	1.5	0.5
Noble fir	369	187	—	—	15.8	9.3	2.3	1.2	0.3
Eastern hemlock	356	180	—	13.3	7.2	4.0	2.2	1.2	0.3
Redwood	315	157	28.5	18.5	10.4	6.0	1.9	0.8	0.3
Sitka spruce	315	157	40.0	19.6	8.3	5.3	2.1	1.0	0.3
Basswood	334	167	—	14.5	9.6	6.0	1.6	1.2	0.3

Source: NFPA *Fire Protection Handbook*, 18th ed., pp. 4-29.

Caution is needed in using Table 3.3.1, as the times and temperatures given are for ignition with a pilot flame. These are good estimates for ignition of wood by an existing fire. These temperatures are not to be used to estimate the temperature necessary for the first item to ignite. The absence of the pilot flame requires that the fuel vapors of the first item ignited be heated to their autoignition temperature. In *An Introduction to Fire Dynamics*, Douglas Drysdale reports two temperatures for wood to autoignite or spontaneously ignite. These are heating by radiation, 600°C (1112°F), and heating by conduction, 490°C (914°F).

For spontaneous ignition to occur as a result of radiative heat transfer, the volatiles released from the surface should be hot enough to produce a flammable mixture above its autoignition temperature when it mixes with unheated air. With convective heating on the other hand, the air is already at a high temperature and the volatiles need not be as hot.

Figure 3.3.1(a) illustrates the relationship between ignition energy and time to ignition for thin and thick materials. When exposed to their ignition temperature, thin materials ignite faster than thick materials (e.g., paper vs. plywood) as shown in Figure 3.3.1(b).

FIGURE 3.3.1(a) Relationship of energy source to ignition time for thick and thin materials.

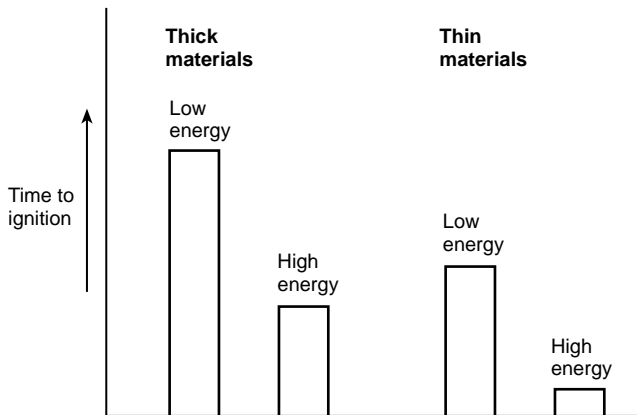
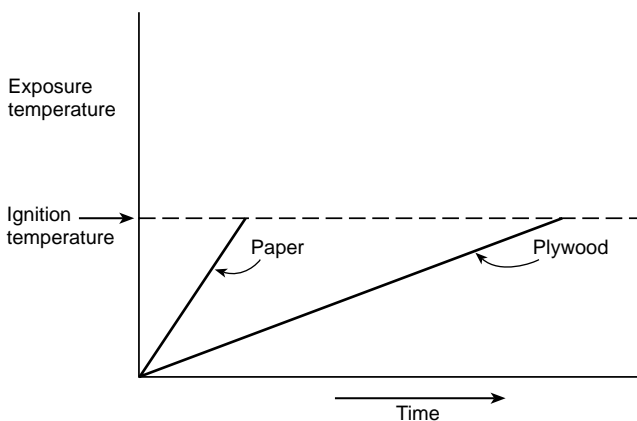

FIGURE 3.3.1(b) Relationship of material thickness to ignition time when exposed to ignition temperature.



3.3.2 Ignition of Liquids. In order for the vapors of a liquid to form an ignitable mixture, the liquid should be at or above its flash point. The flash point of a liquid is the lowest temperature at which it gives off sufficient vapor to support a momentary flame across its surface based on an appropriate ASTM test method. The value of the flash point may vary depending on the type of test used. Even though most of a liquid may be slightly below its flash point, an ignition source can create a locally heated area sufficient to result in ignition.

Atomized liquids or mists (those having a high surface area to mass ratio) can be more easily ignited than the same liquid in the bulk form. In the case of spray or mists, ignition can occur at ambient temperatures below the published flash point of the bulk liquid.

3.3.3 Ignition of Gases. Combustible substances in the gaseous state have extremely low mass and require the least amount of energy for ignition.

3.3.4 Ignition Properties of Materials. Table 3.3.4 provides ignition property data for selected solids, liquids, and gases.

3.3.5 Self-Heating and Self-Ignition. Self-heating is the process whereby a material increases in temperature without drawing heat from its surroundings. Self-heating of a material to its ignition temperature results in self-ignition.

Most organic materials capable of combining with oxygen will oxidize at some critical temperature with the evolution of heat. Generally, self-heating and self-ignition are most commonly encountered in organic materials such as animal and vegetable solids and oils.

Self-heating and self-ignition of materials such as motor or lubricating oils does not occur. Certain inorganic materials, such as metal powders, may undergo self-heating and self-ignition under isolated conditions.

There are three factors that control or influence the occurrence of self-heating and self-ignition:

- (1) The rate of heat generation
- (2) The effects of ventilation
- (3) The insulating effects of the material's immediate surroundings

The rate of heat generation is slow. In order for self-ignition to occur, the rate of heat generation by the material undergoing self-heating should be faster than the rate at which the heat is being dissipated or transferred to its immediate surroundings. When the temperature of the self-heating material increases, the elevated temperatures result in an increase in the rate of heat generation. In all cases, however, the initial temperature of the pile can affect its ability to self-heat. Occasionally, products have been stacked while warm, resulting in self-heating that would not otherwise have occurred.

The effects of ventilation are also significant. In order for self-ignition to occur, sufficient air should be available to permit oxidation but not so much that the heat is carried away by convection as rapidly as it is being generated. As such, the material should be sufficiently porous to allow for oxygen to permeate through the mass to the point of combustion, and the material should also char.

A rag saturated with linseed oil, for example, that might self-heat and self-ignite when crumpled at the bottom of a wastebasket, would not be expected to do so if hung on a clothesline where effects of ventilation through air movement would dissipate the heat faster than it is being generated.

Table 3.3.4 Ignition Properties of Selected Materials

Material	Ignition Temperature		Minimum Radiant Flux (kW/m ²)	Energy Required (kJ/m ²)	Minimum Ignition Energy (mJ)
	°F	°C			
Solids					
Polyethylene ^a	910	488	19	1500-5100	—
Polystyrene ^a	1063	573	29	1300-6400	—
Polyurethane (flexible) ^a	852-1074	456-579	16-30	150-770	—
PVC ^a	945	507	21	3320	—
Softwood ^b	608-660	320-350	—	—	—
Hardwood ^b	595-740	313-393	—	—	—
Dusts (cloud) ^c					
Aluminum	1130	610	—	—	10
Coal	1346	730	—	—	100
Grain	805	430	—	—	30
Liquids ^d					
Acetone	869	465	—	—	1.15 ^e
Benzene	928	498	—	—	0.22 ^e
Ethanol	685	363	—	—	—
Gasoline (100 octane)	853	456	—	—	—
Kerosene	410	210	—	—	—
Methanol	867	464	—	—	0.14 ^e
Methyl ethyl ketone	759	404	—	—	0.53 ^e
Toluene	896	480	—	—	2.5 ^f
Gases ^d					
Acetylene	581	305	—	—	0.02 ^e
Methane	999	537	—	—	0.28 ^e
Natural gas	900-1170	482-632	—	—	0.30 ^f
Propane	842	450	—	—	0.25 ^e

^aFrom NFPA *Fire Protection Handbook*, 17th ed., Table A.6.

^bFrom NFPA *Fire Protection Handbook*, 17th ed., pp. 3-25.

^cFrom NFPA *Fire Protection Handbook*, 16th ed., Table 5.9A.

^dIgnition temperatures from NFPA *Fire Protection Guide to Hazardous Materials*.

^eFrom the SFPE *Handbook of Fire Protection Engineering*, Table 2-5.2.

^fFrom NFPA *Fire Protection Handbook*, 15th ed., Table 11.3B.

Closely related to the effects of ventilation is the insulating effect of the material's immediate surroundings. The crumpled rag saturated with linseed oil at the bottom of a wastebasket is insulated by both the rag itself and the wastebasket. This insulating effect results in the heat being retained within the material and not being as quickly dissipated to the material's immediate surroundings. In a large pile of material, the pile itself may provide enough insulation to allow self-heating in the core of the pile.

Because of the many possible combinations of these controlling or influencing factors, it is difficult to predict with any certainty when a material will self-heat. Table 3.3.5 lists a few materials subject to self-heating. A more complete list is found in Table A.10 of the NFPA *Fire Protection Handbook*, 18th edition. Omission of any material does not necessarily indicate that it is not subject to self-heating.

Table 3.3.5 Some Materials Subject to Spontaneous Ignition

Material	Tendency
Charcoal	High
Fish meal	High
Linseed oiled rags	High
Brewing grains	Moderate
Latex foam rubber	Moderate
Hay	Moderate
Manure	Moderate
Wool wastes	Moderate
Baled rags	Variable (low to moderate)
Sawdust	Possible
Grain	Low

Source: NFPA *Fire Protection Handbook*, 18th ed., p. A-15.

3.3.6 Transition to Flaming Combustion. When flaming combustion is initiated by a smoldering source such as a cigarette, or by self-heating, the process leading up to the appearance of the first flame may be quite slow. Once flaming combustion begins, however, the development of the fire may be faster than if the original ignition source were a flame, due to preheating of the fuel.

3.4 Fuel Load. The term *fuel load* has been used in the past to indicate the potential severity of a fire and has been expressed in terms of Btu (British thermal unit) or pounds of fuel per square foot of floor area. The Btus were expressed in wood equivalent based on 8000 Btu per pound. The fuel load was determined by weighing the fuel in a room and converting the weight of plastic to pounds of wood using 16,000 Btu per pound as the value for plastic (one pound of plastic equals two pounds of wood). The total Btus (or pounds of fuel) were divided by the area of the room floor. While this approach can be a measure of the total heat available if all the fuel burns, it does not depict how fast the fire will develop once the fire starts. The speed of development of a fire determined from witness statements is often used as evidence of an incendiary fire if the fire grew faster than would be expected given the fuel load present.

Total fuel load in the room has no bearing on the rate of growth of a given fire in its preflashover phase. During this period of development, the rate of fire growth is determined by the heat release rate (HRR) from the burning of individual fuel arrays. This rate is controlled by the chemical and physical properties of the fuel and the surface area of the fuel array. HRR is expressed in terms of Btu/second or kilowatts. After flashover, the heat release rate in the fire is controlled by the preceding factors and the availability of air and the exposed combustible surface.

Pine shavings, for example, burn faster than a block of wood of the same weight. Finely ground wood flour dispersed in air burns very rapidly and can result in an explosion. Plastics can have heat release rates significantly greater than the same item made of cellulose. Compare a cotton mattress to one of the same size but made of polyurethane foam. (See Table 3.4.) The difference between these materials relates not only to the chemical composition of the fuel but also to the physical properties, including those that determine the thermal inertia. (See 3.2.1.)

Low-density materials burn faster than high-density materials of similar chemistry. Soft pine, for example, burns faster than oak, and lightweight foam plastics burn faster than more dense, rigid plastics. Peak heat release rate values for typical fuels are presented in Table 3.4. These values should be considered representative values for typical similar fuel items. The actual peak heat release rate for a particular item is best determined by test.

3.5 Fire Development. The rate and pattern of fire development depend on a complex relationship between the burning fuel and the surrounding environment. In confined burning, the collection of heat at the top of the room can raise the temperature of the ceiling and produce a large body of high-temperature smoke. The radiation from this upper portion of the space can significantly enhance the rate of heat release from a burning item. In such cases, the values given in Table 3.4 would be inappropriately low.

3.5.1 Plumes. Heat from a fire in the open rises as a column of hot gas called a plume. The resulting airflow draws cool air into the base of the fire from all directions. Cool air is also drawn into the plume above ground level by the moving mass of hot air, as shown in Figure 3.5.1(a). This inflow of cool air into the plume

is called entrainment and results in decreased temperatures with increasing height in the plume, as shown in Figure 3.5.1(b).

Fire spread will be primarily by radiant ignition of nearby fuels. Spread rate over solids will generally be slow unless aided by air movement (wind) or sloping surfaces.

Table 3.4 Representative Peak Heat Release Rates (unconfined burning)

Fuel (lb)	Peak HRR (kW)
Wastebasket, small (1.5-3)	4-18
Trash bags, 11 gal with mixed plastic and paper trash (2 ¹ / ₂ -7 ¹ / ₂)	140-350
Cotton mattress (26-29)	40-970
TV sets (69-72)	120-290
Plastic trash bags/paper trash (2.6-31)	120-350
PVC waiting room chair, metal frame (34)	270
Cotton easy chair (39-70)	290-370
Gasoline/kerosene in 2 ft ² (0.61 m ²) pool	400
Christmas trees, dry (14-16)	500-650
Polyurethane mattress (7-31)	810-2630
Polyurethane easy chair (27-61)	1350-1990
Polyurethane sofa (113)	3120

Sources: Values are from the following publications:
 Babrauskas and Krasny, *Fire Behavior of Upholstered Furniture*.
 NFPA 72, *National Fire Alarm Code*[®], 1996 ed., B.2.2.2.1.
 Lee, *Heat Release Rate Characteristics of Some Combustible Fuel Sources in Nuclear Power Plants*.

FIGURE 3.5.1(a) Fire plume in the open.

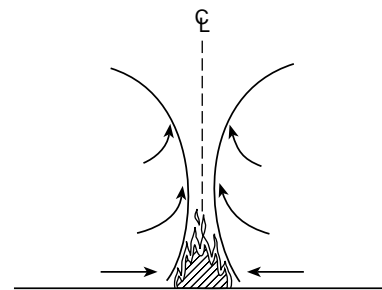
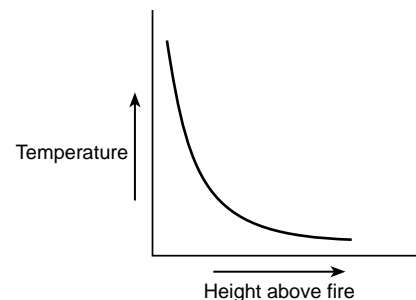

FIGURE 3.5.1(b) Temperature in a fire plume.



3.5.2 Unconfined Fires. When no ceiling exists over a fire, and the fire is far from walls, the hot gases and smoke of the plume continue to rise vertically until they cool to the ambient air temperature. At that point, the smoke will stratify and

diffuse in the air. Such conditions would exist for a fire outdoors. The same conditions can exist with a fire in a building at the very early stages, when the plume is small or if the fire is in a very large-volume space with a high ceiling such as an atrium. Fire spread from an unconfined fire will be primarily by radiant ignition of nearby fuels. The spread rate across solid materials will generally be slow unless aided by air movement (wind in the case of outdoor fires) or sloping surfaces that allow preheating of the fuel.

3.5.3 Confined Fires. When plumes interact with the ceiling or walls of a compartment, the flow of smoke and hot gases and the growth of the fire will be affected. Low heat release rate fires, remote from walls or other bounding surfaces, such as the back of a couch, will behave as if they were in the open.

3.5.3.1 Fires Confined by a Ceiling. When a ceiling exists over a fire, and the fire is far from walls, the hot gases and smoke in the rising plume strike the ceiling surface and spread in all directions until stopped by an intervening wall. As the hot gases flow away from the centerline of the plume under the ceiling, a thin layer is formed. Heat is conducted from this layer into the cooler ceiling above, and cool air is entrained from below. This layer is deepest and hottest near the plume centerline and becomes less deep and cooler as the distance (r) from the centerline of the plume increases. [See Figure 3.5.3.1(a).]

FIGURE 3.5.3.1(a) Fire confined by a ceiling in a large room.

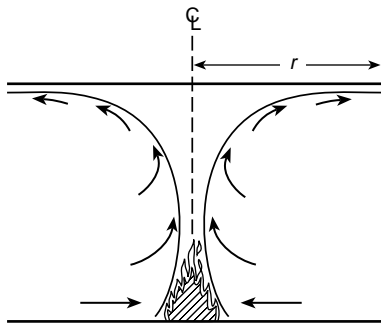

As in the case of the fire in the open, temperatures will decrease with increasing height above the fire. In addition, due to the cooling by entrainment and heat losses to the ceiling, the layer temperature decreases with increased distance (r) from the plume centerline. [See Figure 3.5.3.1(b).]

FIGURE 3.5.3.1(b) Ceiling layer temperature away from the plume.

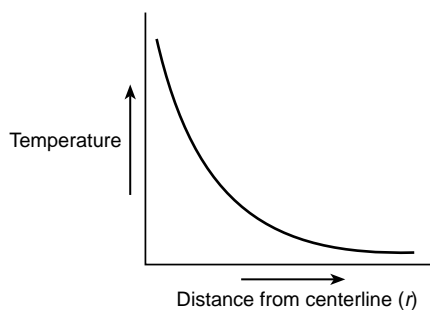

Fire spread with a plume confined by a ceiling will be by ignition of combustible ceiling or wall material, ignition of nearby combustibles such as room contents or warehouse stock, or a combination of these mechanisms. The gases in the upper (smoke) layer may transfer heat to materials in this upper layer by convection and radiation. Transfer of heat below the smoke layer is dominated by radiation. Fire growth, when the plume is confined by a ceiling, will be faster than when the plume is unconfined.

Factors such as ceiling height and distance from the plume can have significant effects on the response time of fire protection devices, such as heat and smoke detectors and automatic sprinklers. For a given device and fire size (HRR), the response time of the device will increase with higher ceilings and with increasing distance from the plume. Stated another way, the higher the ceiling or the farther away the device, the larger the heat output from the fire will be at the time the device responds. These factors should be considered when attempting to understand why a fire appears to be larger than expected at the time of alarm or sprinkler operation.

3.5.3.2 Compartment Fires and Flashover. The heat output from a fire in a compartment is confined by walls as well as the ceiling. The closer proximity of the walls results in a more rapid development of the hot gas layer at the ceiling and the creation of a much deeper layer. Figure 3.5.3.2(a) depicts a room with a door opening. There are two fuel packages in the room; one is the item first ignited, and the other is the “target” fuel or second item ignited. Initially, the ceiling layer will be thin, resembling the no-wall situation. However, as the gases reach the walls and can no longer spread horizontally, the bottom of the layer will descend and become uniform in depth. Smoke detectors in the compartment of origin will generally respond early in this stage of fire development.

When the smoke level reaches the top of the door opening, as illustrated in Figure 3.5.3.2(b), it will begin to flow out of the compartment. If the rate of smoke production does not exceed the rate of smoke flow out of the compartment, the ceiling layer will not descend further.

If the fire grows in size, the bottom of the ceiling layer will continue to descend, the temperature of the hot smoke and gases will increase, and radiant heat from the layer will begin to heat the unignited target fuel, as shown in Figure 3.5.3.2(c). A well-defined flow pattern will be established at the opening, with the hot combustion products flowing out the top and cool air flowing into the compartment under the smoke layer.

At the start of this stage of burning, there is sufficient air to burn all of the materials being pyrolyzed. This is referred to as fuel-controlled burning. As the burning progresses, the availability of air may continue to be sufficient and the fire may continue to have sufficient oxygen even as it grows. Normally, this would be a location that had a large door or window opening as compared to fuel surface burning. In such cases, the gases collected at the upper portion of the room, while hot, will contain significant oxygen and relatively small amounts of unburned fuel.

If the amount of air resident in the room, plus that transported to the room through the HVAC system or drawn in through openings, is not sufficient to burn all of the combustibles being pyrolyzed by the fire, the fire will shift from fuel control to ventilation control. In that situation, the ceiling layer will contain unburned products of combustion such as hydrocarbon vapors, carbon monoxide, and soot. In general, there will be insufficient oxygen for flaming in the ceiling layer. In both cases, the gases can be well above the temperatures necessary to char or pyrolyze combustible finished materials in the hot layer.

FIGURE 3.5.3.2(a) Early compartment fire development.

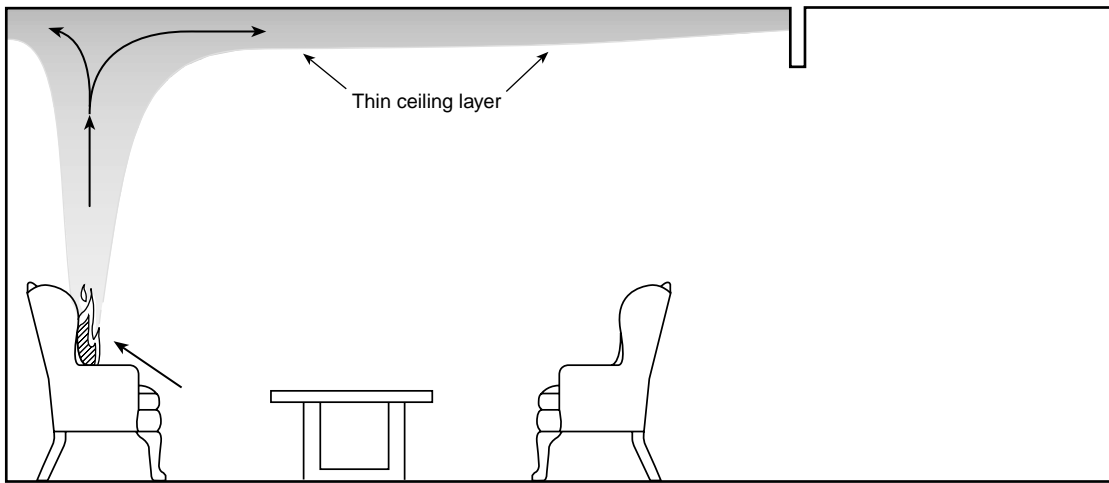

FIGURE 3.5.3.2(b) Ceiling layer development in compartment fire.

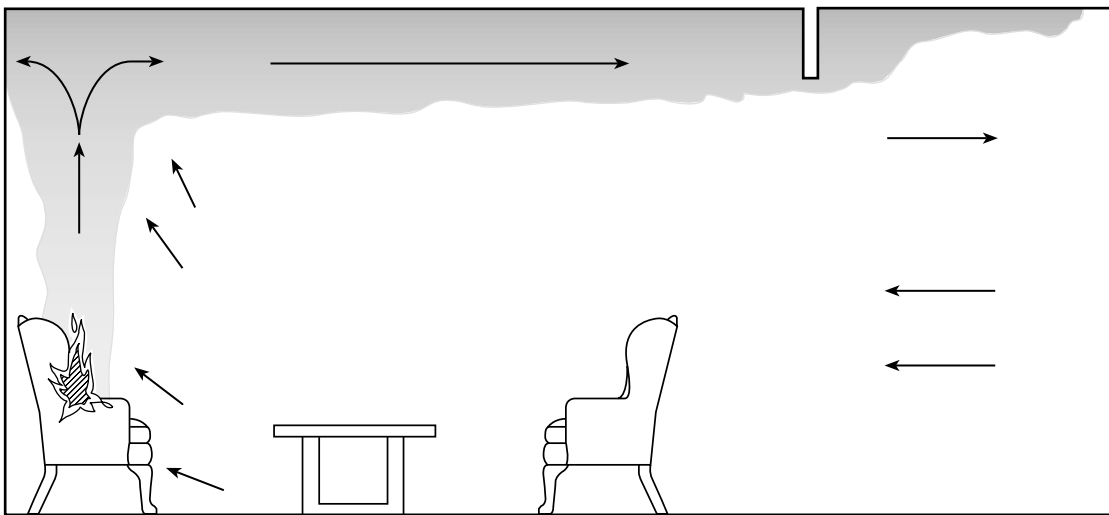
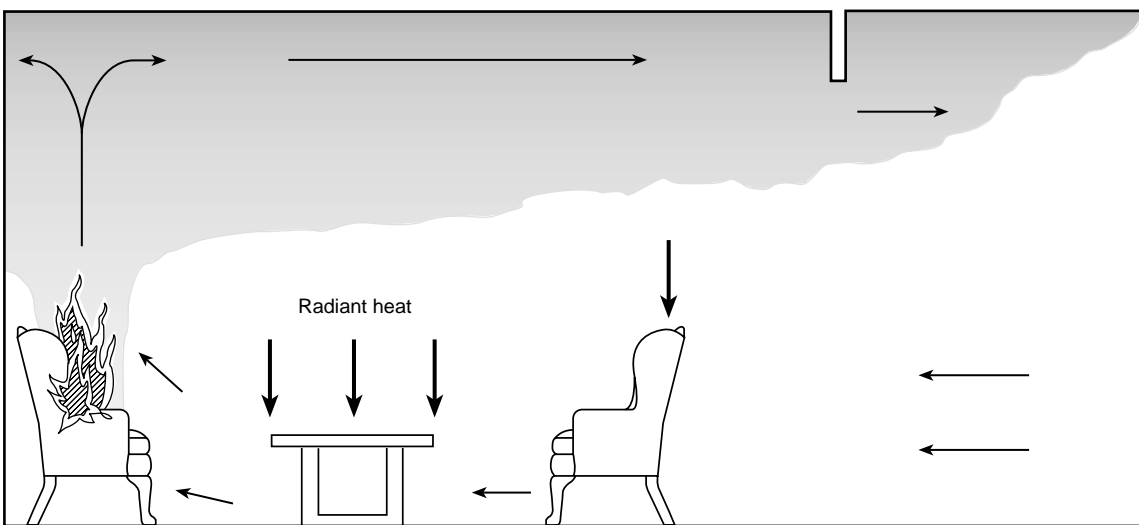

FIGURE 3.5.3.2(c) Preflashover conditions in compartment fire.



Automatic sprinklers will normally operate early during this phase or even during the prior phase of burning. Quick-response sprinklers will operate much sooner than standard sprinklers. Detectors located outside the compartment may operate, depending on their location and the ability of smoke to travel from the fire to the point of the detector.

As the fire continues to grow, the ceiling layer gas temperatures approach 900°F (480°C), increasing the intensity of the radiation on the exposed combustible contents in the room. The surface temperature of these combustible contents rises, and pyrolysis gases are produced and become heated to their ignition temperature. When the upper layer temperature reaches approximately 1100°F (590°C), pyrolysis gases from the combustible contents ignite along with the bottom of the

ceiling layer. This phenomenon, known as flashover, is illustrated in Figure 3.5.3.2(d). The terms *flameover* and *rollover* are often used to describe the condition where flames propagate through or across the ceiling layer only and do not involve the surfaces of target fuels. Flameover or rollover generally precede flashover but may not always result in flashover.

Postflashover burning conditions in a compartment are turbulent and dynamic. During postflashover burning, the position of the ceiling layer bottom and the existence and size of flaming on target fuels within the layer can vary between the conditions shown in Figures 3.5.3.2(d) and 3.5.3.2(e). While the burning of floors or floor coverings is common, such burning may not always extend under target fuels or other shielding surfaces.

FIGURE 3.5.3.2(d) Flashover conditions in compartment fire.

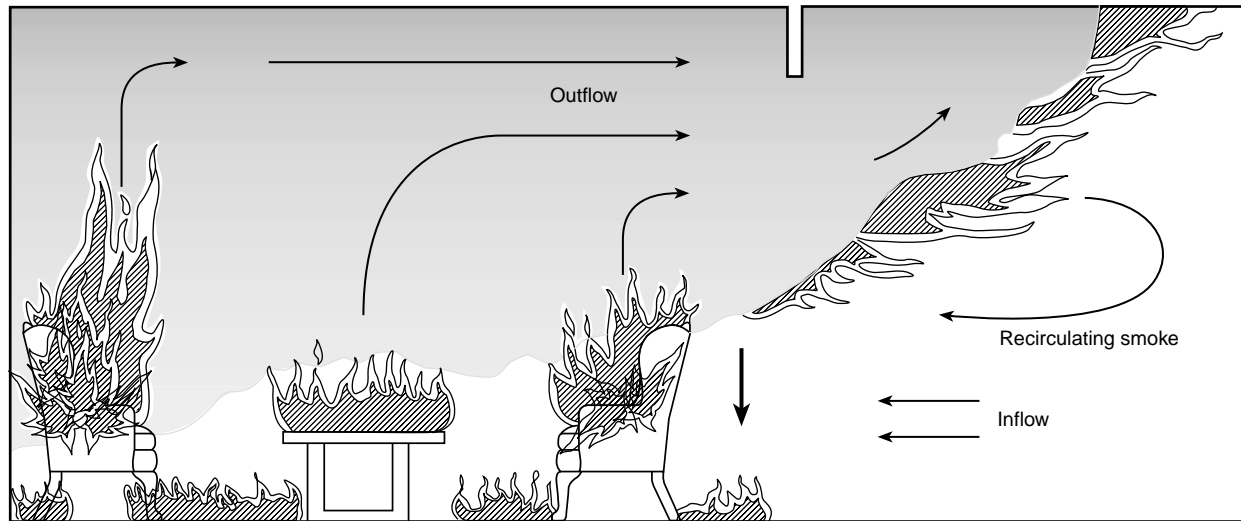
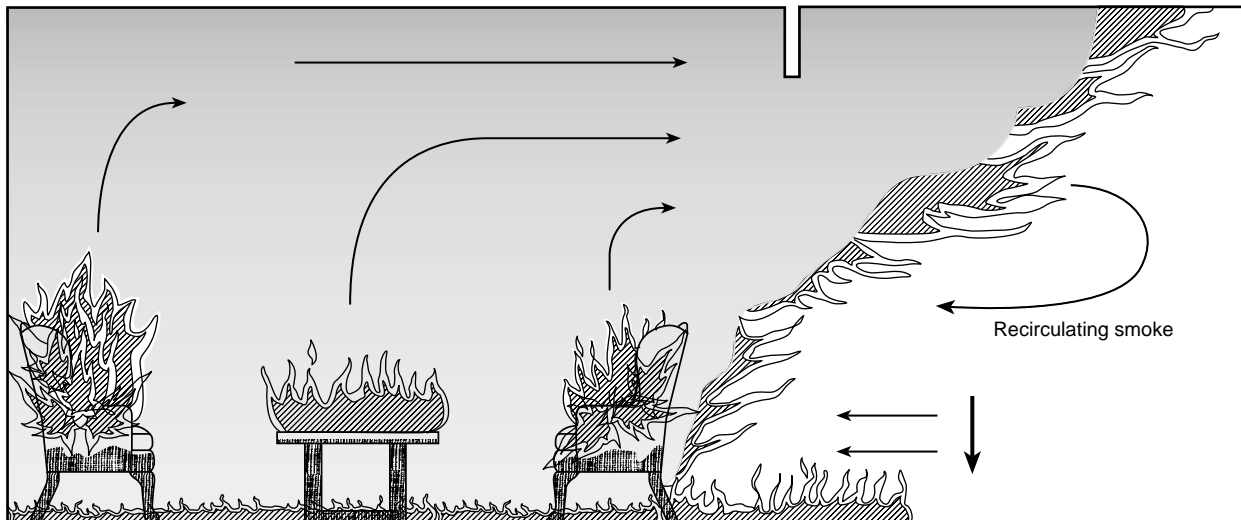

FIGURE 3.5.3.2(e) Postflashover or full room involvement in compartment fire.



Flashover represents a transition from a condition where the fire is dominated by burning of the first item ignited (and nearby items subject to direct ignition) to a condition where the fire is dominated by burning of all items in the compartment. It is important for investigators to be aware of the fact that flashover is a triggering condition, not a closed-ended event. The postflashover condition is called *full room involvement*. The onset of flashover occurs when the hot gas layer imposes radiant energy levels (flux) on unignited fuels of approximately 20 kW/m². This flux level is usually sufficient to ignite ordinary combustible materials. Flux levels in full room involvement are considerably higher than at the beginning of flashover. Levels at the floor of 170 kW/m² have been recorded. See Table 3.5.3.2 for the effects of various heat fluxes.

Once flashover conditions have been reached, full room involvement will follow in the majority of fires unless the fuel is exhausted, the fire is oxygen deprived, or the fire is extinguished. In full room involvement, the hot layer can be at floor level, but tests and actual fires have shown the hot layer is not always at floor level. [See Figure 3.5.3.2(e).]

At the time of flashover, the compartment door becomes a restriction to the amount of air available for combustion inside the compartment, and the majority of the pyrolysis products will burn outside the compartment. Flameover or rollover generally occurs prior to flashover but may not always result in flashover conditions throughout a compartment, particularly where there is a large volume or high ceiling involved or there is limited fuel present.

Research has shown that time to flashover from open flame can be as short as 1¹/₂ minutes in residential fire tests with contemporary furnishings, or it may never occur. The rate of heat release from a fully developed room flashover can be on the order of 10,000 kW (10 MW) or more.

3.5.4 Effects of Enclosures on Fire Growth. For a fire in a given fuel package, the size of the ventilation opening, the volume of the enclosure, the ceiling height, and the location of the fire with respect to the walls and corners will affect the overall fire growth rate in the enclosure.

3.5.4.1* Ventilation Opening. The minimum size fire that can cause a flashover in a given room is a function of the ventilation provided through an opening. This function is known as the *ventilation factor* and is calculated as the area of the opening (A_o) times the square root of the height of the opening (h_o).

An approximation of the heat release rate for flashover (HRR_{fo}) can be found from the following relationship:

$$HRR_{fo}(\text{kW}) = (750 A_o)(h_o)^{0.5}$$

where:

HRR_{fo} = heat release rate for flashover
 A_o = area of opening in m²
 h_o = height of opening in m

The same formula using English units is:

$$HRR_{fo}(\text{Btu/s}) = 18.4 A_o (h_o)^{0.5} + 0.69 A_w$$

where:

HRR_{fo} = heat release rate for flashover
 A_o = area of opening in ft²
 h_o = height of opening in ft

Table 3.5.3.2 Approximate Rate of Radiant Flux

Approximate Radiant Heat Flux (kW/m ²)	Comment or Observed Effect
170	Maximum heat flux as currently measured in a postflashover fire compartment.
80	Heat flux for protective clothing Thermal Protective Performance (TPP) Test. ^a
52	Fiberboard ignites spontaneously after 5 seconds. ^b
29	Wood ignites spontaneously after prolonged exposure. ^b
20	Heat flux on a residential family room floor at the beginning of flashover. ^c
16	Human skin experiences sudden pain and blisters after 5-second exposure with second-degree burn injury. ^a
12.5	Wood volatiles ignite with intended exposure ^d and piloted ignition.
10.4	Human skin experiences pain with 3-second exposure and blisters in 9 seconds with second-degree burn injury. ^{a,b}
6.4	Human skin experiences pain with a second exposure and blisters in 18 seconds with second-degree burn injury. ^{a,e}
4.5	Human skin becomes blistered with a 30-second exposure, causing a second-degree burn injury. ^a
2.5	Common thermal radiation exposure while fire fighting. ^f This energy level may cause burn injuries with prolonged exposure.
≤1.4	Thermal radiation from the sun. Potential sunburn in 30 minutes or less. ^g

Note: The unit kW/m² defines the amount of heat energy or flux that strikes a known surface area of an object. The unit (kW) represents 1000 watts of energy and the unit (m²) represents the surface area of a square measuring 1 m long and 1 m wide. For example, 1.4 kW/m² represents 1.4 multiplied by 1000 and equals 1400 watts of energy. This surface area may be that of the human skin or any other material. Sources:

^aFrom NFPA 1971, *Standard on Protective Ensemble for Structural Fire Fighting*.

^bFrom Lawson, "Fire and the Atomic Bomb."

^cFrom Fang and Breese, "Fire Development in Residential Basement Rooms."

^dFrom Lawson and Simms, "The Ignition of Wood by Radiation," pp. 288-292.

^eFrom Tan, "Flare System Design Simplified," pp. 172-176.

^fFrom U.S. Fire Administration, "Minimum Standards on Structural Fire Fighting Protective Clothing and Equipment."

^gFrom Bennet and Myers, "Momentum, Heat, and Mass Transfer."

A log versus log graph of the HRR for a range of ventilation factors is shown in Figure 3.5.4.1. If the room dimensions are known, a closer approximation can be found using the following relationship:

$$\text{HRR}_{f_o}(\text{kW}) = (378A_o)(h_o)^{0.5} + 7.8A_w$$

where:

HRR_{f_o} = heat release rate for flashover

A_o = area of ventilation opening in m^2

A_w = area of walls, ceiling, and floor in m^2

FIGURE 3.5.4.1 Minimum heat release rate for flashover.

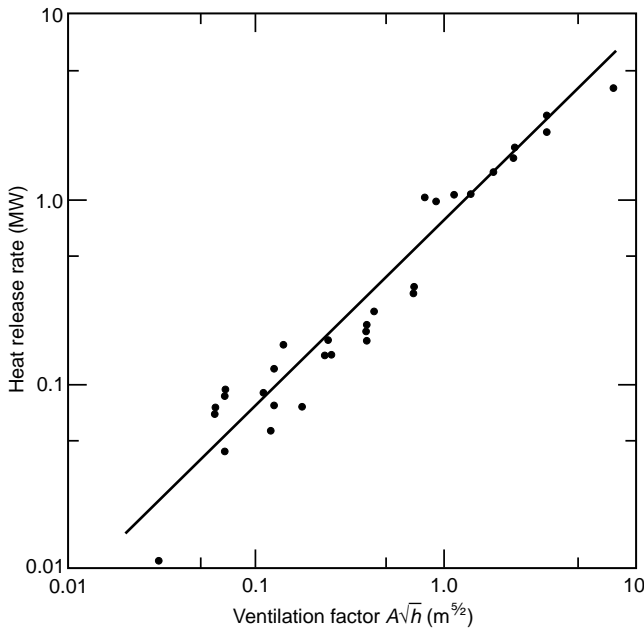

This relationship accounts for heat losses to the bounding surfaces of the room (i.e., the walls, ceiling, and floor). If the losses to the floor are small, then the floor area can be deleted from the value of A_w . The same formula using English units is:

$$\text{HRR}_{f_o}(\text{Btu/s}) = 18.4A_o(h_o)^{0.5} + 0.69A_w$$

where A_o and A_w are in ft^2 and h_o is in ft.

3.5.4.2 Room Volume and Ceiling Height. Development of a ceiling layer of sufficient temperature to cause radiant ignition of exposed combustible fuels and the layer gases is necessary for flashover. High ceilings or large compartment volumes will delay this buildup of temperature and therefore delay or possibly prevent flashover from occurring. The distance between the bottom of the hot layer and the combustible fuel is also a factor but of less importance.

3.5.4.3 Location of the Fire in the Compartment. When a burning fuel package is away from a wall, air is free to flow into the plume from all directions and mix with the fuel gases. This brings air for combustion into the flame zone and cools the upper part of the plume by entrainment. (See 3.5.1.)

If the fuel package or the fire plume is against a wall (not in a corner), air will be able to enter the plume from only

about half of the theoretical circle around it. This will result in longer flames and a faster rise in the temperature of the gases in the ceiling layer. This, in turn, leads to flashover sooner than if the same fuel package had been in the center of the compartment.

When the same fuel package is placed in a corner, 75 percent of the airflow into the plume is restricted, resulting in even longer flames, higher plume and ceiling layer temperatures, and shorter times to flashover.

It should be noted that walls or other barriers to airflow will affect flame length and plume temperature outdoors as well.

The possible effect of the location of walls relative to the fire should be considered in interpreting the extent of damage as a clue to fire origin. In making the determination, the possibility that the fuel in the suspected area of origin was not the first material ignited and that the greater degree of damage was the result of wall or corner effects should be considered.

3.5.5* Flame Height. The height of flames above the surface of burning fuels is directly related to the HRR of the fire. For a given fuel, the HRR is related to the amount of surface burning. If the flame height of a fire is known or can be estimated, the approximate HRR can be determined. The height of the flame is related to the heat output of a simple pool or single item fire by the relationship:

$$H_f = 0.174(k\dot{Q})^{0.4}$$

If the flame height is known, the heat release rate can be estimated by using the following formula:

$$\dot{Q} = \frac{79.18H_f^{5/2}}{k}$$

where:

H_f = flame height in meters

k = wall effect factor

\dot{Q} = fuel heat release rate in kilowatts

The value of k to be used is as follows:

$k = 1$ when there are no nearby walls

$k = 2$ when the fuel package is at a wall

$k = 4$ when the fuel package is in a corner

For a typical wastebasket fire of 150 kW where there are no nearby walls ($k = 1$), this yields an estimated flame plume of 1.3 m (4.3 ft). For an upholstered chair, where the heat is \dot{Q} on the order of 500 kW, the plume would be about 2.1 m (6.9 ft) in height.

3.6 Products of Combustion. The chemical products of combustion can vary widely depending on the fuels involved and the amount of air available. Complete combustion of hydrocarbon fuels containing only hydrogen and carbon will produce carbon dioxide and water. Materials containing nitrogen, such as silk, wool, and polyurethane foam, produce nitrogen oxides and possibly hydrogen cyanide as combustion products. Literally hundreds of compounds have been identified as products of incomplete combustion of wood.

When less air is available for combustion, as in ventilation-controlled fires, the production of carbon monoxide increases as does the production of soot and unburned fuels.

Combustion products exist in all three states of matter: solid, liquid, and gas. Solid material makes up the ash and soot products that represent the visible “smoke.” Many of the other products of incomplete combustion exist as vapors or as extremely small tarry droplets or aerosols. These vapors and droplets often condense on surfaces that are cooler than the smoke, resulting in smoke patterns that can be used to help determine the origin and spread of the fire. Such surfaces include walls, ceilings, and glass. Since the condensation of residue results from temperature differences between the smoke body and the affected surface, the presence of a deposit is evidence that smoke did engulf the surface, but the lack of deposit or the presence of a sharp line of demarcation is not evidence of the limits of smoke involvement.

Soot and tarry products often accumulate more heavily on ceramic-tiled surfaces than on other surrounding surfaces due to the heat conduction properties of ceramic tile. Those surfaces that remain the coolest the longest tend to collect the most condensate.

Some fuels, such as alcohol or natural gas, burn very cleanly, while others, such as fuel oil or styrene, will produce large amounts of sooty smoke even when the fire is fuel controlled.

Smoke is generally considered to be the collection of the solid, liquid, and gaseous products of incomplete combustion.

Smoke color is not necessarily an indicator of what is burning. While wood smoke from a well-ventilated or fuel-controlled wood fire is light-colored or gray, the same fuel under the low-oxygen conditions, or ventilation-controlled conditions in a postflashover fire, can be quite dark or black. Black smoke also can be produced by the burning of other materials, including most plastics and ignitable liquids.

The action of fire fighting can also have an effect on the color of the smoke being produced. The application of water can produce large volumes of condensing vapor that will appear white or gray when mixed with black smoke from the fire. This result is often noted by witnesses at the fire scene and has been misinterpreted to indicate a change of fuel being burned.

Smoke production rates are generally less in the early phase of a fire but increase greatly with the onset of flashover, if flashover occurs.

Chapter 4 Fire Patterns

4.1 Introduction. One of the major objectives of a fire scene examination is the recognition, identification, and analysis of fire patterns. The analysis of fire patterns is performed in an attempt to trace fire spread, identify areas and points of origin, and identify the fuels involved.

The circumstances of every fire are different from every other fire because of the differences in the structures, fuel loads, ignition factors, airflow, ventilation, and many other variable factors. This discussion, therefore, cannot cover every possible variation in fire patterns and how they come about. The basic principles are covered here, and the investigator should apply them to the particular fire incident under investigation.

4.2 Dynamics of Pattern Production. The recognition, identification, and proper analysis of fire patterns by an investigator depends on an understanding of the dynamics of fire development and heat and flame spread. This reorganization, identification, and proper analysis includes an understanding

of the way that the three modes of heat transfer (conduction, convection, and radiation) produce the fire patterns and the nature of flame, heat, and smoke movement within a structure. (See Chapter 3.)

The damage created by flame, radiation, hot gases, and smoke creates patterns that investigators use to locate the area or point of fire origin.

The patterns seen by an investigator can represent much of the history of the fire. Each time another fuel package is ignited or the ventilation to the fire changes, the rate of energy production and heat distribution will change. Any burning item can produce a plume and thus a fire pattern. Determining which pattern was produced at the point of origin by the first material ignited usually becomes more difficult as the size and duration of the fire increase.

The means by which patterns can arise are discussed here. Guidance on the use and interpretation of patterns is found in Chapters 4 and 15.

4.2.1 Plume-Generated Patterns. The shape of the plume of rising hot gases above a burning item can be described as a cone, with its apex directed down toward the source of heat. When undisturbed, the angle between the plume boundaries and vertical is approximately 15 degrees. Near the source of heat, the sides diverge to form a cone describing the boundary of the flame zone.

As gases rise in the plume, they are cooled by air entrainment, and as the plume temperatures approach that of the surrounding air, the upper boundaries spread outward. The presence of a physical barrier, such as a ceiling, will contribute to the lateral extension of the plume boundary.

When a plume is truncated by a vertical surface, such as a wall surface, V- or U-shaped damage patterns can be created on the surface. In the hot gas portion of the plume, the V will be upright. In the flame zone, the damage pattern will resemble an inverted V. Taken together, the overall pattern is often described as an hourglass, as shown in Figure 4.2.1(a).

The plume width varies with the size of the base of the fire and will increase over time as the fire spreads. A narrow pattern will develop from a small surface area fire, and a wide pattern will develop from a fire with a large surface area. However, the angles of the legs of the V will remain at approximately 10–15 degrees, regardless of the heat release rate (HRR) of the fuel, as shown in Figure 4.2.1(b).

Although an undisturbed plume above a flaming fire will have boundaries sloping outward at approximately 15 degrees, airflow in the vicinity can cause the plume to become unstable, resulting in larger angles. Fire plumes adjacent to combustible surfaces may also produce larger angles.

FIGURE 4.2.1(a) Hourglass pattern.

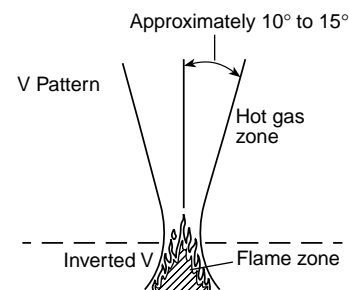
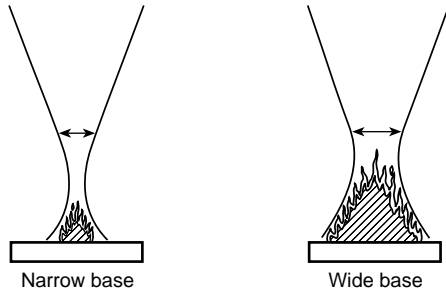

FIGURE 4.2.1(b) Effects of fire base on V width.



Where the surface is combustible, the fire will often spread laterally, expanding the width of the burn pattern beyond that which would have been present on a noncombustible surface. The extent of spread will depend on the flame spread properties of the surface, its orientation to other burning materials, and the temperature of any hot gases impinging on it. In such instances, the pattern can leave marks vastly different from the expected 10–15 degree slope of a single plume.

4.2.2 Ventilation-Generated Patterns. Blowing air over glowing embers will raise their temperatures and can generate enough heat to melt metals. More heat is transferred by convection as the velocity of the hot gas increases. These phenomena can explain the presence of numerous burn patterns.

Airflow over coals or embers can raise temperatures high enough to burn holes through floors. If a building burns extensively and collapses, embers buried in debris can produce holes in floors. Once a hole is made, air can flow up through the hole, and the burning rate can increase. Careful interpretation of these patterns should be exercised, since they may be mistaken for patterns originating from ignitable liquids. Holes in floors may be caused by glowing combustion, radiation, or an ignitable liquid. Because the surface below a liquid remains cool (or at least below the boiling point of the liquid) until the liquid is consumed, holes in the floor from burning ignitable liquids may result when the ignitable liquid has soaked into the floor or accumulated below the floor level. Evidence other than the hole or its shape is necessary to confirm the cause of a given pattern. (See 4.3.3, 4.16.1.4, and 4.17.7.2.)

When a door is closed on a fire, hot gases (being lighter) can escape through the space at the top of a closed door, resulting in charring. Cool air may enter the compartment at the bottom of the door, as in Figure 4.2.2(a). In a fully developed room fire where the hot gases extend to the floor, the hot gases may escape under the door and cause charring under the door and possibly through the threshold, as in Figure 4.2.2(b). Charring can also occur if glowing debris falls against the door either on the inside or the outside, as in Figure 4.2.2(c).

Ventilation of fires and hot gases through windows, doors, or other openings in a structure greatly increases the velocity of the flow over combustible materials. In addition, well-vented fires burn with higher heat release rates. These factors, combined with higher radiation temperatures, can act to burn wood at a higher rate and can spall concrete or deform metal components. Areas of great damage are indicators of a high heat release rate, ventilation effects, or long exposure. Such areas, however, are not always the point of fire origin. For example, fire could spread from slow-burning fuels to rapid-burning fuels with the latter producing most of the fire damage.

FIGURE 4.2.2(a) Airflow around door.

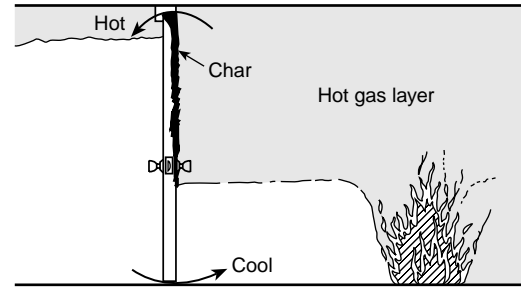

FIGURE 4.2.2(b) Hot gases under door.

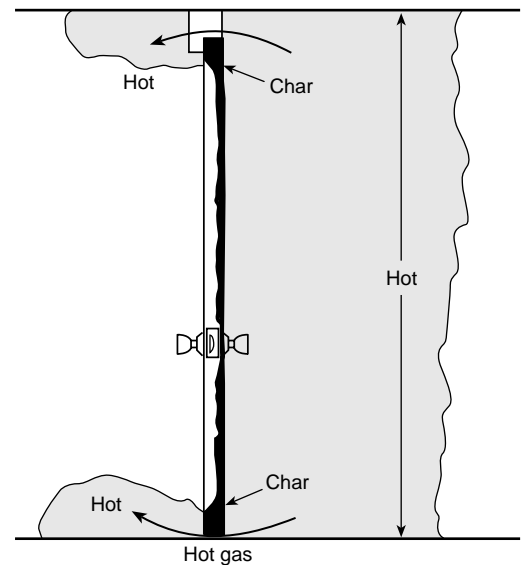
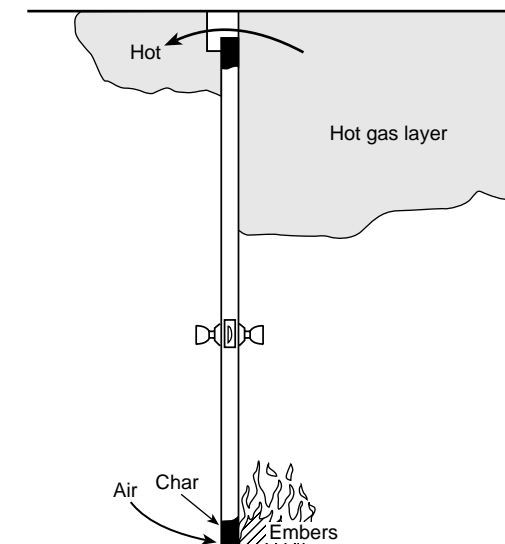

FIGURE 4.2.2(c) Glowing embers at base of door.



4.2.2.1* Effects of Room Ventilation on Pattern Magnitude and Location. The ventilation of the room of fire origin has a great effect on the growth and heat release rate of a fire, and for this reason greatly affects pattern formation. It was found in limited, full-scale testing that patterns that indicated areas of intense burning remote from the point of origin were observed and appeared to be from ventilation effects only. This result was observed in rooms that had flashover conditions where clean burn areas were produced under a window that had been broken during the fire, away from the origin. It was observed as areas of intense burning on furniture items near a door opening as truncated cone patterns on walls opposite door openings.

The effect of ventilation on the intensity of the fire, as well as the location, shape, and damage magnitude of patterns being used to determine the origin of the fire should be considered. Where fresh air ventilation is available to a fire, it is not uncommon to find locally heavy damage patterns on combustible items close to the ventilation opening, patterns which may have no relevance to the point of origin.

4.2.3 Hot Gas Layer–Generated Patterns. The radiant flux from the overhead hot gas layer can produce damage to the upper surfaces of contents and floor covering materials. This process commonly begins as the environment within the room approaches flashover conditions. Similar damage to floor surfaces from radiant heat frequently occurs in adjacent spaces outside rooms that are fully involved in fire. Damage to hallway floors and porches are examples. If the fire does not progress to full room involvement (*see 3.5.3.2*), the damage may include blistering, charring, or melting. Protected surfaces may exhibit no damage. At this time in the fire development, a line of demarcation representing the lower extent of the hot gas layer may form on vertical surfaces. The degree of damage generally will be uniform except where there is drop down, burning of isolated items that are easily ignited, or protected areas. Damage to the undersides of furnishings below the bottom of the hot layer is unlikely.

4.2.4 Patterns Generated by Full Room Involvement. If a fire progresses to full room involvement (*see 3.5.3.2*), damage found at low levels in the room down to and including the floor can be more extensive due to the effects of high radiative flux and the convected heat from the descending hot gas layer. Damage can include charring of the undersides of furniture, burning of carpet under furniture, uniform burning around table legs, burning of baseboards and the undersides of doors, and burning on floor covering in corners. Holes can be burned through carpet and floors. The effects of protected areas and floor clutter on low burn patterns should be considered (*see 4.17.7.2 and 4.18.2*). Although the degree of damage will increase with time, the extreme conditions of the full room involvement can produce major damage in a few minutes, depending on ventilation and fuels present.

4.3 Fire Patterns Defined. Fire patterns are the visible or measurable physical effects that remain after a fire. These include thermal effects on materials, such as charring, oxidation, consumption of combustibles, smoke and soot deposits, distortion, melting, color changes, changes in the character of materials, structural collapse, and other effects.

4.3.1 Lines or Areas of Demarcation. Lines or areas of demarcation are the borders defining the differences in certain heat and smoke effects of the fire on various materials. They appear between the affected area and adjacent unaffected or less affected areas.

The production of lines and areas of demarcation, and the subsequent fire patterns that they define, depend on a combination of variables: the material itself, the rate of heat release of the fire, fire suppression activities, temperature of the heat source, ventilation, and the amount of time that the material is exposed to the heat.

For example, a particular material may display the same heat exposure patterns from exposure to a low-temperature heat source for a long period of time as to a high-temperature heat source for a shorter period of time. The investigator should keep this concept in mind while analyzing the nature of fire patterns.

4.3.2 Surface Effect. The nature and material of the surface that contains the fire pattern will have a bearing on the shape and nature of the pattern itself.

The shape and texture of the surface can affect the actual shape of the lines of demarcation displayed or increase or decrease the amount of pyrolysis and combustion by differing surface areas. If both a smooth and rough surface of the same material are exposed to the same source of heat, the rougher surface will sustain more damage. This is a result of the turbulence of the hot gases interacting with the surface as well as an increase in the surface-to-mass ratio. Differing surface coverings, such as paint, tiles, brick, wallpaper, plaster, and so forth, may increase or decrease the rate of heat treatment or burning.

Combustible surfaces will be darkened by the beginnings of pyrolysis, be burned, or be in various stages of charring, including the total loss of material. Noncombustible surfaces, such as mineral materials or metals, may exhibit color changes, oxidation, physical distortions, or melting.

4.3.3 Penetrations of Horizontal Surfaces. Penetration of horizontal surfaces, from above or below, can be caused by radiant heat, direct flame impingement, or localized smoldering with or without the effects of ventilation.

Penetrations in a downward direction are often considered unusual because the more natural direction of heat movement is upward through the action of buoyancy. In fully flashed-over compartments, however, hot gases may be forced through small, pre-existing openings in a floor, resulting in a penetration. Penetrations may also arise as the result of intense burning under furniture items such as polyurethane mattresses, couches, or chairs. Flaming or smoldering under collapsed floors or roofs can also lead to floor penetrations. Downward penetration, such as a hole burned into a floor or tabletop, may need to be noted and analyzed by the investigator.

Whether a hole burned into a horizontal surface was created from above or below may be identified by an examination of the sloping sides of the hole. Sides that slope downward from above toward the hole are indicators that the fire was from above. Sides that are wider at the bottom and slope upward toward the center of the hole indicate that the fire was from below. (*See Figure 4.3.3.*)

Another reliable means of determining whether a fire moved up through or down through a surface is to compare the extent of destruction on the two levels separated by the surface. If fire moved up through the surface, the damage to the bottom side of the penetrated surface will be more extensive when compared to the top side. The converse is true where the fire moved downward.

It is, of course, possible for both upward and downward movement to occur through a hole during the course of a fire. The investigator should keep in mind that only the last movement through the hole may be evident.

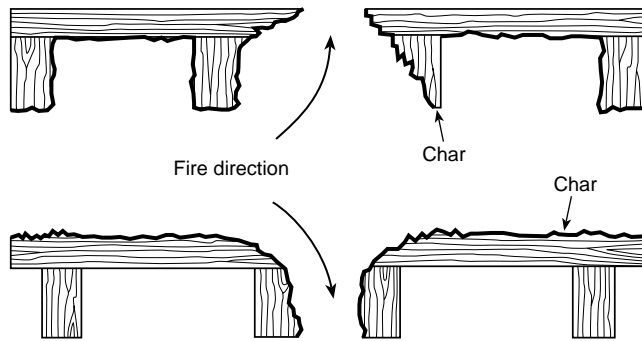
FIGURE 4.3.3 Burn pattern with fire from above and below.

4.3.4 Loss of Material. Typically, when wood or other combustible surfaces burn, they lose material and mass. The shapes and quantities of remaining combustibles can themselves produce lines of demarcation and, ultimately, fire patterns to be analyzed by the investigator.

For example, the fact that the tops of wooden wall studs are burned away at progressively lower heights can be used in the “pointer and arrow” fire pattern analysis of fire spread.

4.3.5 Victim Injuries. The investigator should carefully note and document the position and condition of any fire victims and their relationship to other objects or victims. Autopsy reports and medical records may provide useful information regarding burn damage. For example, burn damage patterns and protected areas can be used in a similar way as damage to furniture and other items discussed in previous sections.

4.4 Types of Fire Patterns. There are two basic types of fire patterns: movement patterns and intensity patterns. These types of patterns are defined largely by the fire dynamics discussed in Chapter 3. Often a systematic use of more than one type of fire pattern at a fire scene can be used in combination to lead back to the heat source that produced them.

4.4.1 Movement Patterns. Flame and heat movement patterns are produced by the growth and movement of fire and the products of combustion away from an initial heat source. If accurately identified and analyzed, these patterns can be traced back to the origin of the heat source that produced them.

4.4.2 Intensity (Heat) Patterns. Flame and heat intensity patterns are produced by the response of materials to the effects of various intensities of heat exposure. The various heat effects on a certain material can produce lines of demarcation. These lines of demarcation may be helpful to the investigator in determining the characteristics and quantities of fuel materials, as well as the direction of fire spread.

4.5 Surface Effect of Char. Many surfaces are decomposed in the heat of a fire. The binder in paint will char and darken the color of the painted surface. Wallpaper and the paper surface of gypsum wallboard will char when heated. Vinyl and other plastic surfaces on walls, floors, tables, or counters also will discolor, melt, or char. Wood surfaces will char, but, because of the greater significance of wood char, it is being treated in greater detail in 4.5.1 through 4.5.5.

The degree of discoloration and charring can be compared to adjacent areas to find the areas of greatest burning.

4.5.1 Wood Char. Charred wood is likely to be found in nearly all structural fires. When exposed to elevated temperatures, wood undergoes chemical decomposition that drives off

gases, water vapor, and various pyrolysis products as smoke. The solid residue that remains is mainly carbon. Char shrinks as it forms, and develops cracks and blisters.

4.5.2* Rate of Charring. The depth of char measurements should not be relied on to determine the duration of the burning. The rule of 1 in. (2.54 cm) in 45 minutes for the rate of charring of pine is based on one set of laboratory conditions in a test furnace. Fires may burn with more or less intensity during the course of an uncontrolled fire than under a controlled laboratory fire. Actual laboratory char rates from exposure to heat from one side vary from 0.4 in. (1 cm) per hour at 750°F (390°C) to 10 in. (25.4 cm) per hour at temperatures approaching 2000°F (1090°C) in intense fires. Even these figures will vary with the species of the wood, orientation of the grain, moisture content, and other variables. Charring rate is also a function of the velocity of hot gases and the ventilation conditions. Fast-moving gases or ventilation can lead to rapid charring.

The rate of charring and burning of wood in general has no relation to its age once the wood has been dried. Wood tends to gain or lose moisture according to the ambient temperature and humidity. Thus, old dry wood is no more combustible than new kiln-dried wood if they have both been exposed to the same atmospheric conditions.

Overall, the use of the nature of char to make determinations about fuels involved in a fire should be done with careful consideration of all the possible variables that can affect the speed and severity of burning.

4.5.3 Depth of Char. Analysis of the depth of charring is most reliable for evaluating fire spread, rather than for the establishment of specific burn times or intensity of heat from adjacent burning materials. By measuring the relative depth and extent of charring, the investigator may be able to determine what portions of a material or construction were exposed the longest to a heat source. The relative depth of char from point to point is the key to appropriate use of charring — locating the places where the damage was most severe due to exposure, ventilation, or fuel placement. The investigator may then deduce the direction of fire spread, with decreasing char depths being farther away from the heat source.

4.5.3.1 Depth of Char Diagram. Lines of demarcation that may not be obvious can often be identified for analysis by a process of measuring and charting depths of char on a grid diagram. By drawing lines connecting points of equal char depth (isochars) on the grid diagram, lines of demarcation may be identified.

4.5.3.2 Depth of Char Analysis. Certain key variables affect the validity of depth of char pattern analysis. These factors include the following.

(a) Single versus multiple heat or fuel sources creating the char patterns being measured. Depth of char measurements may be useful in determining more than one fire or heat source.

(b) Comparison of char measurements, which should be done only for identical materials. It would not be valid to compare the depth of char from a 2 in. by 4 in. stud to the depth of char of an adjacent wooden wall panel.

(c) Ventilation factors influencing the rate of burning. Wood can exhibit deeper charring when adjacent to a ventilation source or an opening where hot fire gases can escape.

(d) Consistency of measuring technique and method. Each comparable depth of char measurement should be made with the same tool and same technique. (See Chapter 13.)

4.5.3.3 Measuring Depth of Char. Consistency in the method of measuring the depth of char is the key to accurate figures. Sharp pointed instruments, such as pocket knives, are not suitable for accurate measurements. The sharp end of the knife will have a tendency to cut into the noncharred wood beneath.

Thin, blunt-ended probes, such as certain types of calipers, tire tread depth gauges, or specifically modified metal rulers are best.

The same measuring tool should be used for any set of comparable measurements. Nearly equal pressure for each measurement while inserting the measuring device is also necessary for accurate results.

Char depth measurements, illustrated in Figure 4.5.3.3(a), should be made at the center of char blisters, rather than in or near the crevasses between blisters. Dial calipers with depth probes of round cross-section, shown in Figure 4.5.3.3(b), are excellent depth of char measurement tools. Figure 4.5.3.3(c) illustrates their use.

When determining the depth of charring, the investigator should take into consideration any burned wood that may have been completely destroyed by the fire and add that missing depth of wood to the overall depth measurement.

FIGURE 4.5.3.3(a) Measuring depth of char.

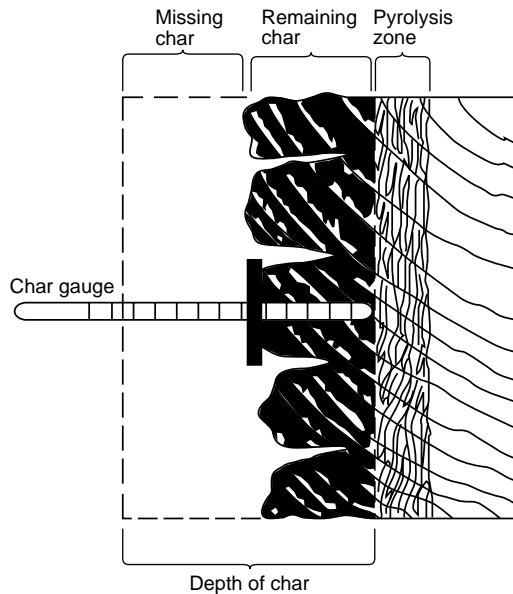

FIGURE 4.5.3.3(b) Dial calipers with depth probes.

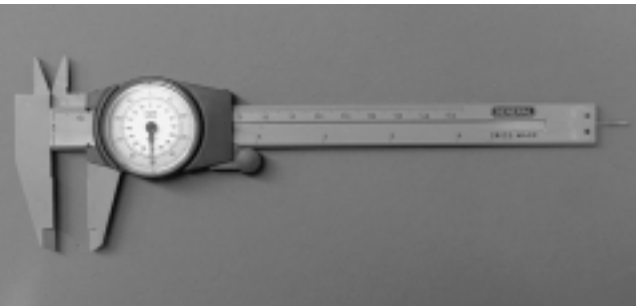
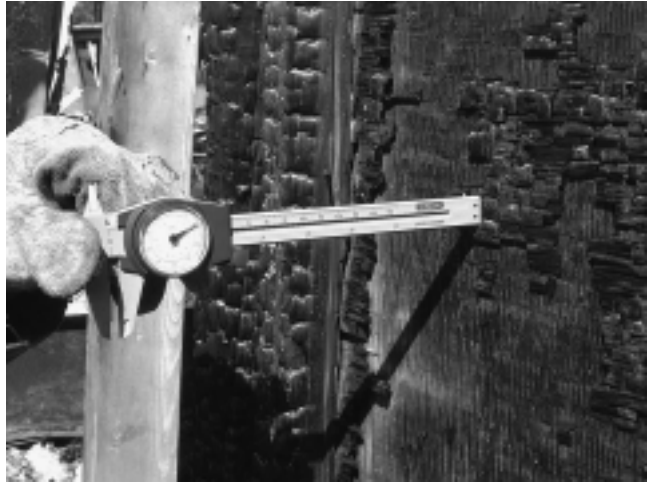

FIGURE 4.5.3.3(c) Using dial calipers to measure depth of char.



4.5.4 Depth of Char Patterns with Fuel Gases. When fugitive fuel gases are the initial fuel sources for fires, they produce relatively even depths of char over the often wide areas that they cover.

Progressive changes in depth of char that are used by investigators to trace fire spread may exist only in those areas to which the fire spreads from the initial locations of the pocketed fuel gases.

Deeper charring may exist in close proximity to the point of gas leakage, as burning may continue there after the original quantity of gas is consumed. This charring may be highly localized because of the pressurized gas jets that can exist at the immediate point of leakage and may assist the investigator in locating the leak.

4.5.5 Interpretation of Char. The appearance of the char and cracks has been given meaning by the fire investigation community beyond what has been substantiated by controlled experimentation. It has been widely stated that the presence of large shiny blisters (alligator char) is proof that a liquid accelerant was present during the fire. This is a misconception. These types of blisters can be found in many different types of fires. There is no justification that the appearance of large, curved blisters is an exclusive indicator of an accelerated fire. Figure 4.5.5, showing boards exposed to the same fire, illustrates the variability of char blister.

It is sometimes claimed that the surface appearance of the char, such as dullness, shininess, or colors, has some relation to the use of a hydrocarbon accelerant or the rate of fire growth. There is no scientific evidence of such a correlation, and the investigator is advised not to claim indications of accelerant or fire growth rate on the basis of the appearance of the char alone.

Depth of char is often used to estimate the duration of a fire. The rate of charring of wood varies widely depending upon such variables as the following:

- (1) Rate and duration of heating
- (2) Ventilation effects
- (3) Surface area to mass ratio
- (4) Direction, orientation, and size of wood grain
- (5) Species of wood (pine, oak, fir, etc.)
- (6) Moisture content
- (7) Nature of surface coating

FIGURE 4.5.5 Variability of char blister.

The investigator is cautioned that no specific time of burning can be determined based solely on depth of char.

4.6 Spalling. Spalling is the breakdown in surface tensile strength of concrete, masonry, or brick caused by exposure to high temperatures and rates of heating resulting in mechanical forces within the material. These forces are believed to result from one or more of the following:

- (1) Moisture present in uncured or “green” concrete
- (2) Differential expansion between reinforcing rods or steel mesh and the surrounding concrete
- (3) Differential expansion between the concrete mix and the aggregate (This is most common with silicon aggregates.)
- (4) Differential expansion between the fine-grained surface finished layers and the coarser-grained interior layers
- (5) Differential expansion between the fire exposed surface and the interior of the slab

Spalling of concrete or masonry surfaces may be caused by heat, freezing chemicals, or abrasion. It may be induced more readily in poorly formulated or finished surfaces. Spalling is characterized by distinct lines of striation and the loss of surface material, resulting in cracking, breaking, and chipping or in the formation of craters on the surface.

Spalling of concrete, masonry, or brick has often been linked to unusually high temperatures caused by burning accelerant. While spalling can involve high rates of heat release or a rapid change in temperature, an accelerant need not be involved. The primary mechanism of spalling is the expansion or contraction of the surface while the rest of the mass expands or contracts at a different rate.

Spalled areas may appear lighter in color than adjacent areas. This lightening can be caused by exposure of clean sub-surface material. Adjacent areas may also tend to be sooted.

Another factor in the spalling of concrete is the loading and stress in the material at the time of the fire. Since these high-stress or high-load areas may not be related to the fire location, spalling of concrete on the underside of ceilings or beams may not be directly over the origin of the fire. (See *Figure 4.6.*)

4.6.1* Interpretations of Spalling. In the past, spalling of concrete at a fire scene has been thought to be a positive indicator of a liquid accelerant-involved fire.

The rapid cooling of a heated mass of concrete, brick, or masonry can also cause spalling. A common source of rapid cooling in a fire is extinguishment by water.

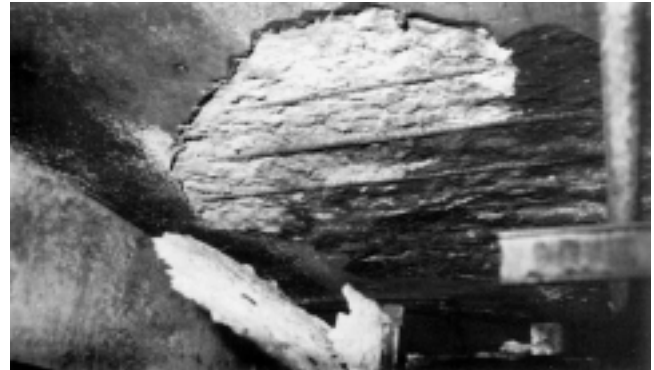
FIGURE 4.6 Spalling on ceiling.

The presence or absence of spalling at a fire scene should not, in and of itself, be construed as an indicator of the presence or absence of liquid fuel accelerant. The presence of ignitable liquids will not normally cause spalling beneath the surface of the liquid. The ability of the surface to absorb or hold the liquid may be a factor in the production of spalling, especially on horizontal surfaces such as concrete floors. For example, a painted or sealed concrete floor is unlikely to spall. Rapid and intense heat development from an ignitable liquid fire may cause spalling on adjacent surfaces, or a resultant fire may cause spalling on the surface after the ignitable liquid burns away.

Since spalling can occur from sources other than fires, it is desirable to determine whether spalling was present prior to the fire.

Overall, it should be noted that the importance of spalling to the fire investigator lies in the documentation and analysis of a heat source.

4.7 Oxidation. Oxidation is the basic chemical process associated with combustion. Oxidation of some materials that do not burn can produce lines of demarcation and fire patterns of use to fire investigators. For these purposes, oxidation may be defined as a combination of oxygen with substances such as metals, rock, or soil that is brought about by high temperatures.

The effects of oxidation include change of color and change of texture. The higher the temperature and the longer the time of exposure, the more pronounced the effects of oxidation will be. Bare galvanized steel with mild heating will get a dull whitish surface from oxidation of the zinc coating. This oxidation also eliminates the protection that the zinc gave the steel. If the unprotected steel is wet for some time, it will then rust. Thus there can be a pattern of rusted compared to non-rusted galvanized steel.

When uncoated iron or steel is oxidized in a fire, the surface first gets a blue-gray dullness. Oxidation can proceed to thick layers of oxide that can flake off. After the fire, if the metal has been wet, the usual rust-colored oxide may appear.

On stainless steel surfaces, mild oxidation can give color fringes, and severe oxidation will give a dull gray color.

Copper forms a dark red or black oxide when exposed to heat. The color is not significant. What is significant is that the oxidation can form a line of demarcation. The thickness of the oxide can show larger fire or more heat. The more it is heated, the greater the oxidation. These color changes can form lines of demarcation. Burn patterns created on metal appliance cabinets may be helpful in determining fire origin and direction of travel.

Rocks and soil, when heated to very high temperatures, will often change colors that may range from yellowish to red.

Soot and char are also subject to oxidation. The dark char of the paper surface of gypsum wallboard, soot deposits, and paint can be oxidized by continued exposure to fire heat. The carbon will be oxidized to gases and disappear from whatever surface it was on. This will result in what is known as clean burn. (See Section 4.11.)

4.8 Melting of Materials. The melting of a material is a physical change caused by heat. The border between the melted and solid portions of a fusible material can produce lines of heat and temperature demarcation that the investigator can use to define fire patterns.

Many solid materials soften or melt at elevated temperatures ranging from a little over room temperature to thousands of degrees. A specific melting temperature or range is characteristic for each material. (See Table 4.8.)

Melting temperatures of common metals range from as low as 338°F to 370°F (170°C to 188°C) for solder to as high as 2660°F (1460°C) for steel. When the metals or their residues are found in fire debris, some inferences concerning the temperatures in the fire can be drawn.

Thermoplastics melt at rather low temperatures, ranging from around 200°F (93°C) to near 750°F (400°C). They can also be consumed in a fire. Thus, the melting of plastics can give information on temperatures, but mainly where there have been hot gases and little or no flame in that immediate area.

Glass melts or softens over a range of temperatures. Nevertheless, glass can give useful information on temperatures during a fire.

4.8.1 Temperature Determination. If the investigator knows the approximate melting temperature of a material, an estimate can be made of the temperature to which the melted material was subjected. This knowledge may assist in evaluating the intensity and duration of the heating, the extent of heat movement, or the relative rates of heat release from fuels.

When using such variable materials as glass, plastics, and white pot metals for making temperature determinations, the investigator is cautioned that there is a wide variety of melting temperatures for these generic materials. The best method for utilizing such materials as temperature indicators is to take a sample of the material and have its melting temperature ascertained by a competent laboratory, materials scientist, or metallurgist.

Wood and gasoline burn at essentially the same flame temperature. The turbulent diffusion flame temperatures of all hydrocarbon fuels (plastics and ignitable liquids) and cellulosic fuels are approximately the same, although the fuels release heat at different rates.

The temperature achieved by an item at a given location within a structure or fire area depends on how much it is heated. The amount of heating depends on the temperature and velocity of the airflow, the geometry and physical properties of the heated item, its proximity to the source of heat, and the amount of heat energy present. Burning metals and highly exothermic chemical reactions can produce temperatures significantly higher than those created by hydrocarbon- or cellulosic-fueled fires.

Identifiable temperatures achieved in structural fires rarely remain above 1900°F (1040°C) for long periods of time. These identifiable temperatures are sometimes called *effective fire temperatures*, for they reflect physical effects that can be defined by specific temperature ranges. The investigator can use the analysis of the melting and fusion of materials to assist in establishing whether higher than expected heat energy was present.

Table 4.8 Approximate Melting Temperatures of Common Materials

Material	°F	°C
Aluminum (alloys) ^b	1050–1200	566–650
Aluminum ^a	1220	660
Brass (yellow) ^b	1710	932
Brass (red) ^b	1825	996
Bronze (aluminum) ^b	1800	982
Cast iron (gray) ^a	2460–2550	1350–1400
Cast iron (white) ^a	1920–2010	1050–1100
Chromium ^a	3350	1845
Copper ^a	1981	1082
Fire brick (insulating) ^a	2980–3000	1638–1650
Glass ^a	1100–2600	593–1427
Gold ^a	1945	1063
Iron ^a	2802	1540
Lead ^a	621	327
Magnesium (AZ31B alloy) ^b	1160	627
Nickel ^a	2651	1455
Paraffin ^a	129	54
Plastics (thermo)		
ABS ^d	190–257	88–125
Acrylic ^d	194–221	90–105
Nylon ^d	349–509	176–265
Polyethylene ^d	251–275	122–135
Polystyrene ^d	248–320	120–160
Polyvinylchloride ^d	167–221	75–105
Platinum ^a	3224	1773
Porcelain ^a	2820	1550
Pot metal ^c	562–752	300–400
Quartz (SiO ₂) ^a	3060–3090	1682–1700
Silver ^a	1760	960
Solder (tin) ^a	275–350	135–177
Steel (stainless) ^b	2600	1427
Steel (carbon) ^b	2760	1516
Tin ^a	449	232
Wax (paraffin) ^c	120–167	49–75
White pot metal ^c	562–752	300–400
Zinc ^a	707	375

^aFrom Baumeister, Avallone, and Baumeister III, *Mark's Standard Handbook for Mechanical Engineers*.

^bFrom Lide, ed., *Handbook of Chemistry and Physics*.

^cFrom NFPA *Fire Protection Guide to Hazardous Materials*.

^dFrom *Plastics Handbook*.

^eFrom Glick and Gieck, *Engineering Formulas*.

4.8.2 Alloying of Metals. The melting of certain metals may not always be caused by fire temperatures higher than the metals' stated melting point. It may be caused by alloying.

During a fire, a metal with a relatively low melting point may drip onto other metals that do not often melt in fires. This phenomenon can also occur when component parts of a heated object are in contact with each other. If the lower-melting-temperature metal can mix with the higher-

melting-temperature metal, that mixture (alloy) will melt at a temperature less than the melting temperature of the higher-melting-temperature metal and in some cases less than that of either metal. Examples of relatively low-melting-temperature metals are aluminum, zinc, and lead. (See *Table 4.8.*) Metals that can be affected by alloying include copper and iron (steel). Copper alloying is often found, but iron (steel) alloying might be found in only a few cases of sustained fire.

Copper wiring and tubing or piping are often affected by alloying. Drips of low-melting-temperature metal may simply stick to the surface if the heating has been brief. With further heating, the low-melting-temperature metal will wet the surface and begin to mix. Aluminum can mix through the wire or wall of the tubing to give a yellow alloy at about 10 percent aluminum, but that is not often found. More commonly, the aluminum will mix in higher proportions and give a brittle silvery alloy. The surface of the spot of aluminum on the surface of the copper may appear gray, and the surface may be fairly dark near the copper-aluminum interface. Copper that has been alloyed with aluminum will be very brittle. For example, bending copper wire at the point of alloying will likely cause it to break there.

When zinc alloys with copper, a yellowish brass will result. Because zinc is less common in buildings than is aluminum, zinc alloying is not often encountered.

Alloys do not form readily with steel in fires. However, if aluminum or zinc is heated for a long time with a steel object, that object may develop pits or holes from alloying.

If fire evidence containing aluminum-alloyed copper is exposed to weather, the alloy may corrode away, leaving neat holes in tubing or blunt ends on wires. Those edges will not have the appearance of melting.

Alloying may be confirmed by metallurgical analysis, and the alloy may be identified. When metals with high melting temperatures are found to have melted due to alloying, it is not an indication that accelerants or unusually high temperatures were present in the fire.

4.9 Thermal Expansion and Deformation of Materials. Many materials change shape temporarily or permanently during fires. Nearly all common materials expand when heated. That expansion can affect the integrity of solid structures when they are made from different materials. If one material expands more than another material in a structure, the difference in expansion can cause the structure to fail.

The bending of steel beams and columns in a fire above about 1000°F (538°C) is caused by the progressive loss of strength of the steel. The more the load on any unrestrained steel object, the more will be the deformation for a given time and temperature. Bending is not a matter of melting. Thermal expansion can also be a factor in the bending of the beam, if the ends of the beam are restrained.

Plastered surfaces are also subject to thermal expansion. Locally heated portions of plaster walls and ceilings may expand and separate from their support lath. This breaking away of the plaster can produce lines or areas of heat demarcation displaying V patterns, U patterns, and truncated cone patterns.

4.10 Smoke and Soot. Fuels that contain carbon can form soot in their flames. Petroleum products and most plastics form soot most readily. When flames touch walls and ceilings, soot will commonly deposit. A specific deposit shows where there has been a particular fuel load. Soot also deposits on surfaces by settling. Such general soot deposits show merely that soot formed nearby but do not indicate the specific source.

Smoke and soot can collect on cooler surfaces of a building or its contents, often on upper parts of walls in rooms adjacent to the fire. Smoke, especially from smoldering fires, tends to condense on walls, windows, and other cooler surfaces. Because deposits of pyrolysis products tend to be widely distributed, they do not help locate the exact point of origin.

Smoke condensates are shades of brown, whereas soot is black. Smoke condensates can be wet and sticky, thin or thick, or dried and resinous. These deposits, after drying, are not easily wiped off. Where there has been open flame, the deposits will likely be a mixture of soot and smoke. When smoke deposits are subsequently heated in a fire, the brown deposit may be changed in color, texture, and composition and may become darker or charred.

Some fires might produce only dry soot deposits that wipe easily from windows or other surfaces. Floors and top surfaces of contents often get a coating of soot that settles on them during and after sooty fires.

Both the carbonized smoke deposit and soot deposits can be burned off of windows or other surfaces by prolonged exposure to fire.

4.11 Clean Burn. Clean burn is a phenomenon that appears on noncombustible surfaces when the soot and smoke condensate that would normally be found adhering to the surface is burned off. This produces a clean area adjacent to areas darkened by products of combustion, as shown in Figure 4.11. Clean burn is produced most commonly by direct flame contact or intense radiated heat.

FIGURE 4.11 Clean burn on wall surface.



Although they can be indicative of intense heating in an area, clean burn areas by themselves do not necessarily indicate areas of origin. The lines of demarcation between the clean burn and sooted areas may be used by the investigator to determine direction of fire spread or differences in intensity or time of burning.

The investigator should be careful not to confuse the clean burn area with spalling. Clean burn does not show the loss of surface material that is a characteristic of spalling.

4.12 Calcination. The term *calcination* is used by fire investigators to cover the numerous changes that occur in plaster or gypsum wall surfaces during a fire. Calcination of a true plaster wall involves driving the chemically bound water out of the gypsum.

The gypsum wallboard most often used has a more complex response to heat than plaster. First the paper surface will char and might also burn off. The gypsum on the side exposed to fire becomes gray from charring of the organic binder and destiffener in it. With further heating, the gray color will go all the way through, and the paper surface on the backside will char. The face exposed to fire will become whiter as the carbon is burned away. When the entire thickness of wallboard has turned whitish, there will be no paper left on either face, and the gypsum will be dehydrated and converted to a crumbly solid. Such a wallboard might stay on a vertical wall but will drop off of an overhead surface. Fire-rated gypsum wallboard has mineral fibers or vermiculite particles embedded in the gypsum to preserve the strength of the wallboard during fire exposure. The fibers add strength to the wallboard even after it has been thoroughly calcined.

Color changes other than shades of gray may occur after gypsum wall surfaces are exposed to heat. The color itself has no significance to the fire investigator. However, the difference between colors may show lines of demarcation.

The relationship between the calcined and not calcined areas on plaster or gypsum wallboard can also display lines of demarcation. [See Figures 4.12(a) and 4.12(b).]

FIGURE 4.12(a) Two instruments that can be used to measure the depth of calcination.

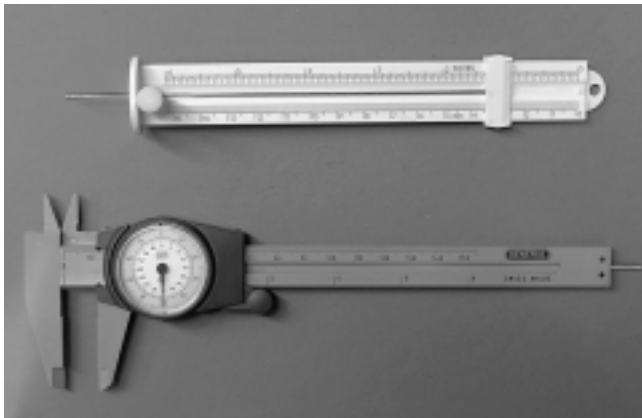

4.12.1* General Indications of Calcination. The calcination of gypsum board is an indicator concerning the heat exposure sustained by the material. The areas of greatest heat exposure may be indicated by both visual appearance and the depth of calcination. The relative differences in color and depth of calcination from point to point may be used as an indicative tool to establish the areas of greater or lesser heat exposure due to all fire condition variables, such as area of origin, ventilation, and fuel load.

4.12.2 Depth of Calcination Diagram. A depth of calcination diagram can be produced in the same manner as that for depth of char. (See 4.5.3.1.)

FIGURE 4.12(b) Measuring depth of calcination on a piece of gypsum wallboard.

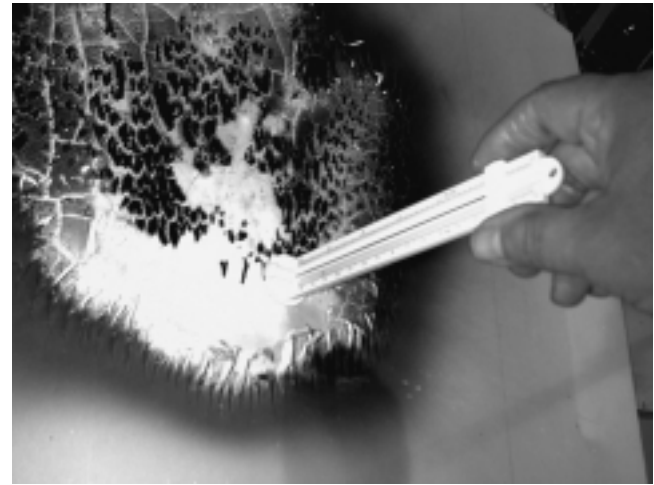

4.12.3 Depth of Calcination Analysis. Certain key variables affect the validity of depth of calcination analysis. These factors include the following.

(a) Single versus multiple heat or fuel sources, creating the calcination patterns being measured, should be considered. Depth of calcination patterns may be useful in determining multiple heat or fire sources.

(b) Comparisons of depth of calcination measurements should be made only from the same material. It should be recognized that gypsum wallboard comes in different thicknesses, uses different materials of construction, and does change with time. The investigator must carefully consider sections of walls or ceilings that may have had new sections inserted as a repair.

(c) The finish of the gypsum wallboard (e.g., paint, wallpaper, stucco) should be considered when evaluating depth of calcination. The investigator should recognize that some of these finishes are combustible and may affect the patterns if they are ignited.

(d) Measurements should be made in a consistent fashion to eliminate errors in this data collection, as discussed in 4.12.4.

(e) Gypsum wallboard can be damaged during suppression, overhaul and post-fire by hose streams and standing water to the point where little or no reliable measurements can be made.

4.12.4 Measuring Depth of Calcination. The technique for measuring and analyzing depth of calcination can use a visual observation of cross sections or a probe survey. The visual method requires careful removal of small sections (minimum approximately 2 in. diameter) of walls or ceilings to observe and measure the thickness of the calcined layer.

4.13 Window Glass. Many texts have related fire growth history or fuels present to the type of cracking and deposits that resulted on window glass. There are several variables that affect the condition of glass after fire. These include the type and thickness of glass, rate of heating, degree of insulation to the edges of the glass provided by the glazing method, degree of restraint provided by the window frame, history of the flame contact, and cooling history.

4.13.1* Breaking of Glass. If a pane of glass is mounted in a frame that protects the edges of the glass from radiated heat of fire, a temperature difference occurs between the unprotected portion of the glass and the protected edge. Experimental research estimates that a temperature difference of about 158°F (70°C) between the center of the pane of glass and the protected edge can cause cracks that start at the edge of the glass. The cracks appear as smooth, undulating lines that can spread and join together. Depending on the degree of cracking, the glass may or may not collapse from its frame.

If a pane of glass has no edge protection from radiated heat of fire, the glass will break at a higher temperature difference. Also, experimental research suggests that fewer cracks are formed, and the pane is more likely to stay whole.

Glass that has received an impact will have a characteristic “cobweb” pattern. The cracks will be in straight lines and numerous. The glass may have been broken before, after, or during the fire.

If flame suddenly contacts one side of a glass pane while the unexposed side is relatively cool, a stress can develop between the two faces and the glass can fracture between the faces.

Crazing is a term used in the fire investigation community to describe a complicated pattern of short cracks in glass. These cracks may be straight or crescent-shaped and may or may not extend through the thickness of the glass. Crazing has been theorized as being the result of very rapid heating of one side of the glass while the other side remains cool. There is no published research to confirm this theory. However, there is published research establishing that crazing can be created by the rapid cooling of glass by the application of water spray in a hot environment.

Occasionally with small size panes, differential expansion between the exposed and unexposed faces may result in the pane popping out its frame.

The pressures alone developed by fires in buildings generally are not sufficient either to break glass windows or to force them from their frames. Pressures required to break ordinary window glass are in the order of 0.3 psi to 1.0 psi (2.07 kPa to 6.90 kPa), while pressures from fire are in the order of 0.002 psi to 0.004 psi (0.014 kPa to 0.028 kPa). If an overpressure has occurred — such as a deflagration, backdraft, or detonation — glass fragments from a window broken by the pressure will be found some distance from the window. For example, an overpressure of 1.5 psi (10.3 kPa) can cause fragments to travel as far as 100 ft (30.3 m).

The investigator is urged to be careful not to make conclusions from glass-breaking morphology alone. Both crazing and long, smooth, undulating cracks have been found in adjacent panes. The small craters or pits found in the surface of glass are believed to be the result of rapid cooling by water spray during fire suppression activities.

4.13.2* Tempered glass, whether broken when heated by fire impact or when exploded, will break into many small cube-shaped pieces. Such glass fragments should not be confused with crazed glass. Tempered glass fragments are more regularly shaped than the complicated pattern of short cracks of crazing.

Tempered glass is commonly found in applications where safety from breakage is a factor, such as in shower stalls, patio doors, TV screens, motor vehicles, and in commercial and other public buildings.

4.13.3 Staining of Glass. Glass fragments that are free of soot or condensates have likely been subjected to rapid heating, failure early in the fire, or flame contact. The proximity of the glass to the area of origin or heat source and ventilation are factors that can affect the degree of staining.

The presence of a thick, oily soot on glass, including hydrocarbon residues, has been interpreted as positive proof of the presence or use of liquid accelerant. Such staining can also result from the incomplete combustion of other fuels such as wood and plastics and cannot be exclusively interpreted as having come from an accelerant.

4.14* Collapsed Furniture Springs. The collapse of furniture springs may provide the investigator with various clues concerning the direction, duration, or intensity of the fire. However, the collapse of the springs cannot be used to indicate exposure to a specific type of heat source or ignition, such as smoldering ignition or the presence of an ignitable liquid. The results of laboratory testing indicate that the annealed springs, and the associated loss of tension (tensile strength), is a function of the application of heat. These tests reveal that short-term heating at high temperatures and long-term heating at moderate temperatures over 750°F (400°C) can result in the loss of tensile strength and in the collapse of the springs. Tests also reveal that the presence of a load or weight on the springs while they are being heated increases the loss of tension.

The value of analyzing the furniture springs is in comparing (comparative analysis) the differences in the springs to other areas of the mattress, cushion, frame, and so forth. Comparative analysis of the springs can assist the investigator in developing hypotheses concerning the relative exposure to a particular heat source. For example, if at one end of the cushion or mattress the springs have lost their tension and the other end has not, then hypotheses may be developed. The hypotheses should take into consideration other circumstances, effects (such as ventilation), and evidences at the scene concerning duration or intensity of the fire, area of origin, direction of heat travel, or relative proximity of the heat source. In any event, the portion with the loss of spring strength may indicate greater relative exposure to heat than those areas without the loss of strength.

Other circumstances and effects that may be considered along with analyzing the springs include the loss of mass and material or depth of char to the frame if constructed of wood. Similar analysis may also include color changes, possibly indicating intensity, in metal frames.

Still other effects for comparative analysis include consideration of the covering material of the springs. The absence of material may indicate a portion closer to the source of heat, while the presence of materials may indicate an area more remote from the heat source.

The investigator should also consider the condition of the springs prior to the fire.

4.15 Location of Objects. Certain types of patterns can be used to locate the positions of objects as they were during a fire.

4.15.1 Heat Shadowing. Heat shadowing results from an object blocking the travel of radiated heat, convected heat, or direct flame contact from its source to the material on which the pattern is produced. Conducted heat, however, does not produce heat shadowing.

The object blocking the travel of the heat energy may be a solid or liquid, combustible or noncombustible. Any object that absorbs or reflects the heat energy may cause the production of a pattern on the material it protects.

Heat shadowing can change, mask, or prohibit the production of identifiable lines of demarcation that may have appeared on that material. Patterns produced by the heat shadowing, may, however, assist the fire investigator in the process of reconstruction during origin determination.

4.15.2 Protected Areas. Closely related in appearance to the resulting pattern of heat shadowing is a protected area. A protected area results from an object preventing the products of combustion from depositing on the material that the object protects, or prevents the protected material from burning.

The object preventing the depositing of products of combustion may be a solid or liquid, combustible or noncombustible. Any object that prevents the settling of the products of combustion, or prevents the burning of the material, may prevent the development of a pattern on the material it protects. Figure 4.15.2 provides an example.

FIGURE 4.15.2 Photograph on top, showing protected area; photograph at bottom, showing how the chair was positioned during the fire.

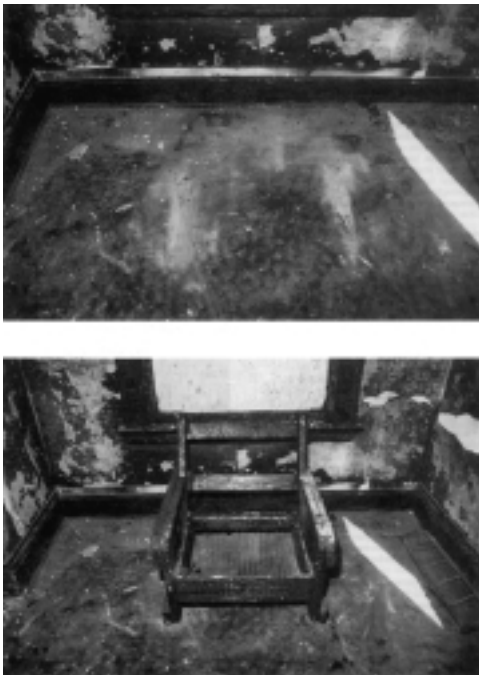

Patterns produced by protected areas may, however, assist the fire investigator in the process of fire scene reconstruction during the origin determination by indicating the location of objects in their pre-fire locations. (See Section 15.7.)

4.16 Locations of Patterns. Fire patterns may be found on any surface that has been exposed to the effects of the fire or its by-products. These surfaces include interior surfaces, external surfaces and structural members, and outside exposures surrounding the fire scene.

Interior surfaces commonly include walls, floors, ceilings, doors, windows, furnishings, appliances, machinery, equipment, other contents, personal property, confined spaces, attics, closets, and the insides of walls.

Exterior surfaces commonly include walls, eaves, roofs, doors, windows, gutters and downspouts, utilities (e.g., meters, service drops), porches, and decks.

Outside exposures commonly include outbuildings, adjacent structures, trees and vegetation, utilities (e.g., poles, lines, meters, fuel storage tanks, and transformers), vehicles, and other objects.

4.16.1 Walls, Ceilings, and Floors. Fire patterns are often found on walls, ceilings, and floors. As the hot gas zone and the flame zone of the fire plume encounter these obstructions, patterns are produced that investigators may use to trace a fire's origin. (See Chapter 3.)

4.16.1.1 Walls. Patterns that are displayed on walls are the most noticeable. The patterns may appear as heat treatment lines of demarcation on the surfaces of the walls or may be manifested as deeper burning. Once the actual surface coverings of the walls are destroyed by burning, the underlying support studs can also display various patterns. These patterns are most commonly V patterns, U patterns, clean burn, and spalling.

4.16.1.2 Ceilings. The investigator should not ignore patterns that occur on ceilings or the bottom surfaces of such horizontal constructions as tabletops or shelves. The buoyant nature of fire gases concentrate the heat energy at horizontal surfaces above the heat source. Therefore, the patterns that are created on the underside of such horizontal surfaces can be indicators of locations of heat sources. Although areas immediately over the source of heat and flame will generally experience heating before the other areas to which the fire spreads, circumstances can occur where fuel at the origin burns out quickly, but the resulting fire spreads to an area where a larger supply of fuel can ignite and burn for a longer period of time. This process can cause more damage to the ceiling than in the area immediately over the origin.

These horizontal patterns are roughly circular. Portions of circular patterns are often found where walls meet ceilings or shelves and at the edges of tabletops and shelves.

The investigator should determine the approximate center of the circular pattern and investigate below this center point for a heat source.

4.16.1.3 Damaged Inside Walls and Ceilings. Fire damage to combustible construction elements behind walls and ceilings has sometimes been interpreted to mean that the fire started within the wall or ceiling. This may not always be correct.

It is possible for the heat of a fire to be conducted through a wall or ceiling surface and to ignite wooden structural members within the wall or ceiling. The ability of the surface to withstand the passage of heat over time is called its finish rating.

While the finish rating of a surface material only represents the performance of the material in a specific laboratory test (e.g., UL 263, *Standard for Safety Fire Tests of Building Construction and Materials*) and not necessarily the actual performance of the material in a real fire, knowledge of the finish ratings concept can be of value to an investigator's overall fire spread analysis.

This heat transfer process can be observed by the charring of the wooden structural element covered by the protective membrane, shown in Figure 4.16.1.3.

4.16.1.4* Floors. Floors should not be ignored by the investigator. Should flashover occur, the transition to flashover is associated with a radiant heat flux that exceeds approximately 20 kW/m^2 (2 W/cm^2) at a mean floor level, typical value for the radiant ignition of common combustible construction materials. Postflashover or full room involvement conditions can typically produce fluxes in excess of 170 kW/m^2 and may modify or obliterate pre-existing patterns.

FIGURE 4.16.1.3 Charring of wooden structural elements by heat conduction through wall surface material.

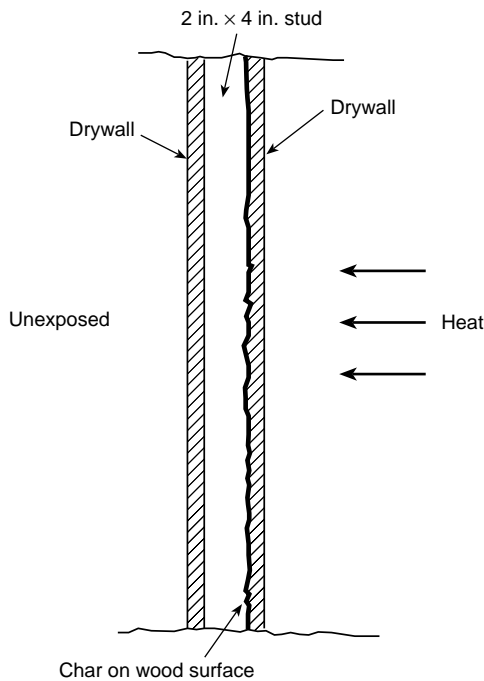

Since 1970, carpeting and rugs manufactured or imported to be sold in the United States have been resistant to ignition or fire spread. Typically, cigarettes or matches dropped on carpets will not set them on fire. ASTM D 2859, *Standard Test Method for Flammability of Finished Textile Floor Covering Materials* (Methanamine Pill Test), describes the test used to measure the ignition characteristics of carpeting from a small ignition source. Carpeting and rugs passing the pill test will have very limited ability to spread flame or char in a horizontal direction when exposed to small ignition sources such as a cigarette or match.

Fire will not spread across a room on the surface of these carpets or rugs without external help, such as from a fire external to the carpet, in which case the fire spread on the carpet will terminate at a point where the radiant energy from the exposing fire is less than the minimum needed to support flame spread on the carpet (critical radiant flux). Carpet is expected to burn when exposed to flashover conditions since the radiant heat flux that produces flashover exceeds the carpet's critical radiant flux.

Burning between seams or cracks of floorboards or around door thresholds, sills, and baseboards may or may not indicate the presence of an ignitable liquid. If the presence of an ignitable liquid is suspected, samples should be collected and laboratory tests should be used to verify their presence. (See Section 14.5.)

Burning from full room involvement can also produce burning of floors or around door thresholds, sills, and baseboards due to radiation, the presence of hot combustible fire gases, or air sources (ventilation) provided by the gaps in construction. These gaps can provide sufficient air for combustion of, on, or near floors (see 4.2.2). If the investigator develops a hypothesis that charring in these areas resulted from these effects, samples can also be taken to indicate an ignitable liquid was not present.

Like other areas of low burning, holes burned in floors can be produced by the presence of ignitable liquids, glowing

embers, or the effects of flashover or full room involvement. The collection of samples and laboratory verification of the presence or absence of ignitable liquid residues may assist the investigator in developing hypotheses and drawing conclusions concerning the development of the holes.

Fire-damaged vinyl floor tiles often exhibit curled tile edges exposing the floor beneath. The curling of tile edges can frequently be seen in nonfire situations and is due to natural shrinkage and curling of the tiles from loss of plasticizer. In a fire, the presence of radiation from a hot gas layer will produce the same patterns. This pattern can also be caused by ignitable liquids. Analysis for their presence may be difficult due to the presence of hydrocarbons in tile adhesives.

Unburned areas present after a fire can reveal the location of content items that protected the floor or floor covering from radiation damage or smoke staining.

4.16.2 Outside Surfaces. External surfaces of structures can also display fire patterns. In addition to the regular patterns, both vertical and horizontal external surfaces can display burn-through. All other variables being equal, these burn-through areas can identify areas of intense or long-duration burning.

4.16.3 Building Contents. The sides and tops of building contents can form the bounding surfaces for fire patterns as well. Any patterns that can be produced on walls, ceilings, and floors can also be produced on the sides, tops, and undersides of chairs, tables, shelves, furniture, appliances, equipment, machinery, or any other contents. The patterns will be similar in shape but may only display portions of patterns because of their size.

4.16.4 Elevation. Patterns can also be used to determine the height at which burning may have begun within the structure.

4.16.4.1 Low Burn Patterns. It is common for the lowest portions of fire patterns to be closer to their heat sources. In general, fires tend to burn upward and outward from their origins. Fire plumes made up of the hot gases and airborne products of combustion are expanding and less dense than the surrounding air and are therefore buoyant. The growth in volume and buoyancy causes these heated products to rise and spread. The investigator should identify these areas of low burning and be cognizant of their possible proximity to a point of origin. The investigator should remember that in a compartment where the fire has transitioned through flashover to the fully developed stage, burning down to floor level is not necessarily indicative of an origin at the floor level.

4.16.4.2 Fall Down (Drop Down). The investigator should keep in mind that during the progress of a fire, burning debris often falls to lower levels and then burns upward from there. This occurrence is known as *fall down* or *drop down*. Fall down can ignite other combustible materials, producing low burn patterns that may be confused with the area of fire origin.

4.17* Pattern Geometry. Various patterns having distinctive geometry or shape are created by the effects of fire and smoke exposure on building materials and contents. In order to identify them for discussion and analysis, they have been described in the field by terms that are indicative of their shapes. While these terms generally do not relate to the manner in which the pattern was formed, the descriptive nature of the terminology makes the patterns easy to recognize. The discussion that follows will refer to patterns by their common names and provide some information about how they were formed and their interpretation. Additional information can be found in Section 4.2.

Since the interpretation of all possible fire patterns cannot be traced directly to scientific research, the user of this guide is cautioned that alternative interpretations of a given pattern are possible. In addition, patterns other than those described may be formed. Definitive scientific research in this area has begun. Separate scientific research studies have begun to delve into the formation and interpretation of fire patterns. The two studies examined both pattern geometries and causal factors.

4.17.1 V Patterns on Vertical Surfaces. The appearance of the V-shaped pattern is created by flames, convective or radiated heat from hot fire gases, and smoke within the fire plume. (See 4.2.1.) The V pattern often appears as lines of demarcation (see 4.3.1) defining the borders of the fire plume and less heated areas outside the plume. An example is shown in Figure 4.17.1.

FIGURE 4.17.1 Typical V pattern showing wall and wood stud damage.



The angle of the V-shaped pattern is dependent on several variables (see 4.2.1), including the following:

- (1) The heat release rate (HRR) and geometry of the fuel
- (2) The effects of ventilation
- (3) The ignitability of the vertical surface on which it appears and combustibility of the vertical surface on which they appear
- (4) The presence of interceding horizontal surfaces such as ceilings, shelves, table tops, or the overhanging construction on the exterior of a building (See 4.2.1.)

The angle of the borders of the V pattern does not indicate the speed of fire growth; that is, a wide V does not indicate a slowly growing fire, or a narrow V does not indicate a rapidly growing fire.

4.17.2 Inverted Cone Patterns. Inverted cones are commonly caused by the vertical flame plumes of the burning volatile fuels not reaching the ceiling.

4.17.2.1 Interpretation of Inverted Cone Patterns. Inverted cone patterns are manifestations of relatively short-lived fires that do not fully evolve into floor-to-ceiling flame plumes or flame plumes that are not vertically restricted by ceilings.

Because they often appear on noncombustible surfaces, they do not always readily spread to nearby combustibles. For this reason, many investigators have taken to inferring from these patterns that the fires that caused them were fast burning.

The correct analysis of such patterns is that the burning was of relatively short duration rather than any relationship to the rate of heat release. That short duration occurred because additional fuel sources did not become involved after the initial fuel was consumed.

Inverted cone patterns have been interpreted as proof of flammable liquid fires, but any fuel source (leaking fuel gas, Class A fuels, etc.) that produces flame zones that do not become vertically restricted by a horizontal surface, such as a ceiling or furniture, can produce inverted cone patterns.

4.17.2.2 Inverted Cone Patterns with Natural Gas. Leaking natural gas is prone to the production of inverted cone patterns. This is especially true in the case of natural gas if the leakage occurs from below floor level and escapes above at the intersection of the floor and a wall, as in Figure 4.17.2.2. The subsequent burning often does not reach the ceiling and is manifested in the production of the characteristic triangular inverted cone pattern shape.

FIGURE 4.17.2.2 Inverted cone pattern fueled by a natural gas leak below the floor level.



4.17.3 Hourglass Patterns. The plume of hot gases above a fire is composed of a hot gas zone shaped like a V and a flame zone at its base. The flame zone is shaped like an inverted V. When the hot gas zone is truncated by a vertical plane surface, the typical V pattern is formed. If the fire itself is very close to or in contact with the vertical surface, the resulting pattern will show the effects of both the hot gas zone and the flame zone together as a large V above an inverted V. The inverted V is generally smaller and may exhibit more intense burning or clean burn. The overall pattern that results is called an *hourglass*. (See 4.2.1.)

4.17.4 U-Shaped Patterns. U patterns are similar to the more sharply angled V patterns but display gently curved lines of demarcation and curved rather than angled lower vertices. (See Figure 4.17.4.) U-shaped patterns are created by the effects

of radiant heat energy on the vertical surfaces more distant from the same heat source than surfaces displaying sharp V patterns. The lowest lines of demarcation of the U patterns are generally higher than the lowest lines of demarcation of corresponding V patterns that are closer to the fire source.

FIGURE 4.17.4 Development of U-shaped pattern.

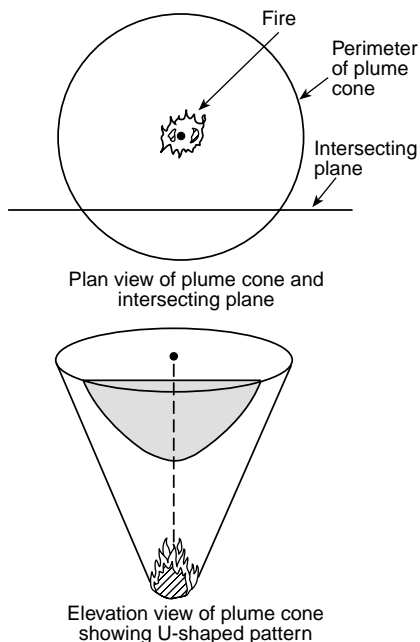

U patterns are analyzed similarly to V patterns, with the additional aspect of noting the relationship between the height of the vertex of the U pattern as compared to the height of the vertex of the corresponding V patterns.

If there are two patterns from the same heat source, the one with the lower vertex will be closer to that heat source.

4.17.5 Truncated Cone Patterns. Truncated cone patterns, also called truncated plumes, are three-dimensional fire patterns displayed on both horizontal and vertical surfaces. (See Figure 4.17.5.) It is the interception or truncating of the natural cone-shaped or hourglass-shaped effects of the fire plume by these vertical and horizontal surfaces that causes the patterns to be displayed. Many fire movement patterns, such as V patterns, U patterns, circular patterns, and “pointer or arrow” patterns, are related directly to the three-dimensional “cone” effect of the heat energy created by a fire.

The cone-shaped dispersion of heat is caused by the natural expansion of the fire plume as it rises and the horizontal spread of heat energy when the fire plume encounters an obstruction to its vertical movement, such as the ceiling of a room. Thermal damage to a ceiling will generally extend beyond the circular area attributed to a “truncated cone.” The truncated cone pattern combines two-dimensional patterns such as V-shaped patterns, pointers and arrows, and U-shaped patterns on vertical surfaces, with the circular patterns displayed on ceilings and other horizontal surfaces.

The combination of more than one two-dimensional pattern on perpendicular vertical and horizontal surfaces gives the truncated cone pattern its three-dimensional character.

FIGURE 4.17.5 Truncated cone pattern.

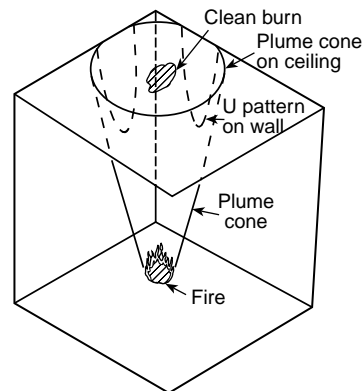

A theoretical demonstration of the truncated cone pattern is when the four vertical walls of a room each display varied V or U patterns, as well as circular or portions of circular patterns appearing on the ceiling. Corresponding patterns may also be discernible on the furnishings in the room.

4.17.6 Pointer and Arrow Patterns. These fire patterns are commonly displayed on a series of combustible elements such as wooden studs or furring strips of walls whose surface sheathing has been destroyed by fire or was nonexistent. The progress and direction of fire spread along a wall can often be identified and traced back toward its source by an examination of the relative heights and burned-away shapes of the wall studs left standing after a fire. In general, shorter and more severely charred studs will be closer to a source of fire than taller studs. The heights of the remaining studs increase as distance from a source of fire increases. The difference in height and severity of charring will be noted on the studs, as shown in Figure 4.17.6(a).

FIGURE 4.17.6(a) Wood wall studs showing decreasing damage as distance from fire increases.

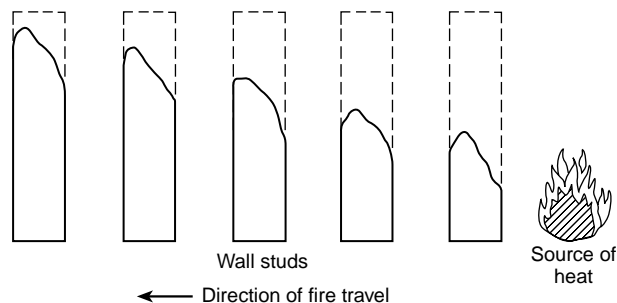

The shape of the studs’ cross section will tend to produce “arrows” pointing back toward the general area of the source of heat. This is caused by the burning off of the sharp angles of the edges of the studs on the sides toward the heat source that produces them, as shown in Figure 4.17.6(b).

More severe charring can be expected on the side of the stud closest to the heat source.

4.17.7 Circular-Shaped Patterns. Patterns that are generally circular in shape are common at fire scenes. These patterns are never truly circular unless they represent areas that have been protected from burning by circular items, such as wastebaskets or the bottoms of furniture items.

FIGURE 4.17.6(b) Cross section of wood wall stud pointing toward fire.

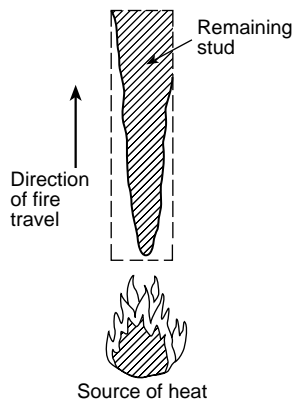

4.17.7.1 Bottoms of Horizontal Surfaces. Patterns on the underside of horizontal surfaces, such as ceilings, tabletops, and shelves, can appear in roughly circular shapes. The more centralized the heat source, the more circular or nearly circular the patterns may appear.

Portions of circular patterns can appear on the underside of surfaces that partially block the heated gases or fire plumes. This appearance can occur when the edge of the surface receiving the pattern does not extend far enough to show the entire circular pattern or when the edge of the surface is adjacent to a wall.

Within the circular pattern, the center may show more heat treatment, such as deeper charring. By locating the center of the circular pattern, the investigator may find a valuable clue to the source of greatest heating, immediately below.

4.17.7.2 Irregular Patterns. Irregular, curved, or “pool-shaped” patterns on floors and floor coverings should not be identified as resulting from ignitable liquids on the basis of observation of the shape alone. In cases of full room involvement, patterns similar in appearance to ignitable liquid burn patterns can be produced when no ignitable liquid is present.

The lines of demarcation between the damaged and undamaged areas of irregular patterns range from sharp edges to smooth gradations depending on the properties of the material and the intensity of heat exposure. Denser materials like oak flooring will generally show sharper lines of demarcation than thermoplastic (e.g., nylon) carpet. The absence of a carpet pad often leads to sharper lines.

These patterns are common in situations of postflashover conditions, long extinguishing times, or building collapse. These patterns may result from the effects of hot gases, flaming and smoldering debris, melted plastics, or ignitable liquids. If the presence of ignitable liquids is suspected, supporting evidence such as the use of a combustible gas indicator, chemical analysis of debris for residues, or the presence of liquid containers should be sought. It should be noted that many plastic materials release hydrocarbon fumes when they pyrolyze or burn. These fumes may have an odor similar to that of petroleum products and can be detected by combustible gas indicators when no ignitable liquid accelerant has been used. A “positive” reading should prompt further investigation and the collection of samples for more detailed chemical analysis. It should be noted that pyrolysis products, including

hydrocarbons, can be detected in gas chromatographic analysis of fire debris in the absence of the use of accelerants. It can be helpful for the laboratory, when analyzing carpet debris, to burn a portion of the comparison sample and run a gas chromatographic analysis on both. By comparing the results of the burned and unburned comparison samples with those from the fire debris sample, it may be possible to determine whether or not hydrocarbon residues in the debris sample were products of pyrolysis or residue of an accelerant. In any situation where the presence of ignitable liquids is suggested, the effects of flashover, airflow, hot gases, melted plastic, and building collapse should be considered.

When overall fire damage is limited, however, and small, or isolated irregular patterns are found, the presence of ignitable liquids may be more likely, although the use of supporting evidence is still recommended. [See Figures 4.17.7.2(a) and 4.17.7.2(b).] Even in these cases, radiant heating may cause the production of patterns on some surfaces that can be misinterpreted as liquid burn patterns. [See Figure 4.17.7.2(c).]

Pooled ignitable liquids that soak into flooring or floor covering materials as well as melted plastic can produce irregular patterns. These patterns can also be produced by localized heating or fallen fire debris.

FIGURE 4.17.7.2(a) Irregular burn patterns on a floor of a room burned in a test fire in which no ignitable liquids were used.



FIGURE 4.17.7.2(b) Irregularly shaped pattern on floor carpeting resulting from poured ignitable liquid. Burned match can be seen at lower left.

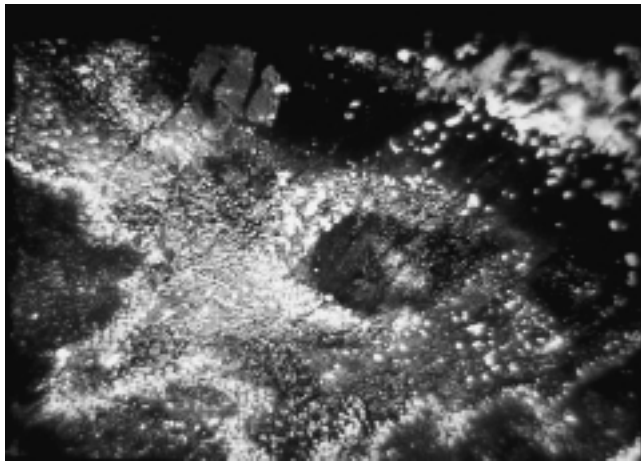

FIGURE 4.17.7.2(c) “Pool-shaped” burn pattern produced by a cardboard box burning on an oak parquet floor.



4.17.7.3 Doughnut-Shaped Patterns. A distinct doughnut-shaped pattern, where a roughly ring-shaped burn area surrounds a less burned area, may result from an ignitable liquid. When a liquid causes this pattern, shown in Figure 4.17.7.3, it is due to the effects of the liquid cooling the center of the pool as it burns, while flames at the perimeter of the doughnut produce charring of the floor or floor covering. When this condition is found, further examination should be conducted as supporting evidence to the presence of ignitable liquids.

FIGURE 4.17.7.3 Doughnut-shaped fire pattern on a carpeted floor.



4.17.8 Liquids Versus Melted Solids. Many modern plastic materials will burn. They react to heating by first liquefying, and then, when they burn as liquids, they produce irregularly shaped or circular patterns. When found in unexpected places, such patterns can be erroneously identified as flammable or combustible liquid patterns and associated with an incendiary fire cause.

Often the association of an ignitable liquid with a particular irregular pattern has been ruled out on the presumption that ignitable liquid vapors will always cause explosions. This is not the case. The expansion of the products of combustion from flammable liquids will cause explosions only if they are sufficiently confined to damage the structure or confining vessel and have the proper fuel-air mixture. (See 3.1.1.2 and 18.8.2.1.) Whether an explosion occurs is a function of the quantity of vaporized fuel present at the time of ignition, the presence of venting openings in the structure, and the strength and construction of the confining structure.

The investigator should be careful to identify properly the initial fuel source for any irregularly shaped or circular patterns.

4.17.9 Commercial Fuel Gas Patterns. The burning of the common commercial fuel gases, natural gas and liquefied petroleum (LP) gases, can provide distinctive fire patterns. Distinctive localized burning between ceiling joists, between interior vertical wall studs, and in the corners of ceilings of rooms is quite common and a good indicator of the presence of natural gas.

Natural gas has a vapor density of 0.65; therefore, it is lighter than air and will rise when released. This property of natural gas will create gas pockets in the upper areas of rooms and structures.

The LP-Gases, being heavier than air (with vapor densities of about 1.5 for propane and 2.0 for butane), also tend to pocket within a structure, though at low levels. However, the buoyant nature of their products of combustion when ignited prevents them from producing similar pocketing burn patterns as natural gas.

4.17.10 Saddle Burns. *Saddle burns* are distinctive U- or saddle-shaped patterns that are sometimes found on the top edges of floor joists. They are caused by fire burning downward through the floor above the affected joist. Saddle burns display deep charring, and the fire patterns are highly localized and gently curved. These patterns are often created by the burning of liquid fuels, (not necessarily ignitable liquids). They also may be created by radiant heat from a burning material in close proximity to the floor (e.g., sofa). Ventilation caused by floor openings may also contribute to the development of these patterns, shown in Figure 4.17.10.

FIGURE 4.17.10 Saddle burn in a floor joist.



4.18 Linear Patterns. Patterns that have overall linear or elongated shapes can be called linear patterns. They usually appear on horizontal surfaces.

4.18.1 Trailers. In many incendiary fires, when fuels are intentionally distributed or “trailed” from one area to another, the elongated patterns may be visible. Such fire patterns, known as *trailers*, can be found along floors to connect separate fire sets, or up stairways to move fires from one floor or level within a structure to another, as shown in Figure 4.18.1. Fuels used for trailers may be ignitable liquids, solids, or combinations of these.

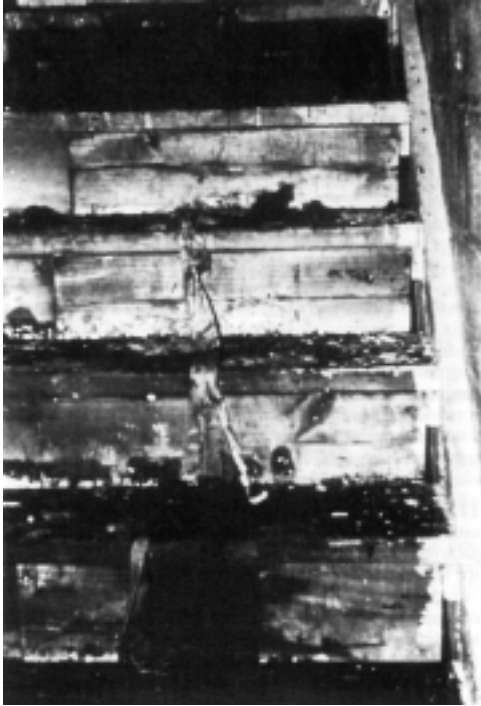
FIGURE 4.18.1 Trailer running up a stairway.

4.18.2 Protected Floor Areas. Often when the floor area is cleared of debris to examine damage, long, wide, straight patterns will be found, showing areas of extensive heat damage bounded on each side by undamaged or less damaged areas. These patterns often have been interpreted to be “trailers.” While this is possible, the presence of furniture, stock, counters, or storage may result in these linear patterns. These patterns may also result from wear on floors and the floor covering due to high traffic. Irregularly shaped objects on the floor, such as clothing or bedding, may also provide protection and produce patterns that may be inaccurately interpreted.

4.18.3 Fuel Gas Jets. Jets of ignited fuel gases, such as LP-Gas or natural gas, can produce linear patterns or lines of demarcation, particularly on noncombustible surfaces.

4.19 Area Patterns. Some patterns may appear to cover entire rooms or large areas without any readily identifiable sources or beginnings. These patterns are most often formed when the fuels that create them are widely dispersed before ignition, or when the movement of the fire through the areas is very rapid, as in a flash fire.

4.19.1 Flashover and Full Room Involvement. In the course of a flashover transition, fire spreads rapidly to all exposed combustible materials as the fire progresses to full room involvement. (See 3.5.3.2.) This process can produce relatively even burning on vertical surfaces. If the fire is terminated before full room involvement, relatively uniform burning can be evident above the bottom of the hot layer. When the fire has progressed to full room involvement, the area pattern may be uneven and may extend to the base of the wall.

4.19.2 Flash Fires. The ignition of gases or the vapors of liquids does not necessarily always cause explosions. Whether or not an explosion occurs depends on the location and concentration of diffuse fuels and on the geometry, venting, and strength of the confining structure. (See Section 18.1.)

If the diffuse fuels are near the lower flammable or explosive limit (LEL) and there is no explosion, the fuels may burn as a flash fire, and there may be little or no subsequent burning. In the instance where the first fuel to be ignited is a diffuse fuel-air mixture, the area of greatest destruction may not, and generally does not, coincide with the area where the heat source ignites the mixture. The greatest destruction will occur where the flash fire from the burning mixture encounters a secondary fuel load that is capable of being ignited by the momentary intense temperature in the flame front. Likewise, once secondary ignition occurs, the dynamics of the fire spread will be dictated by the compartment and fuel geometry and the relative heat release rates of these secondary fuels. The relatively short duration of the burning mixture may have little impact on the flashover in the compartment as compared to the burning of the secondary fuels. Therefore, origin determination of such a flash fire is dependent on accurate witness observations and the analysis of the potential ignition sources in the areas where the vapor or gas could have existed.

Without accurate witness statements and careful analysis of potential ignition sources, the investigator is left with the analysis of fire patterns as the only means of determining the origin. The difficulty of this task is that the resultant ignition of the secondary fuels and compartment flashover can camouflage the subtle patterns created by the flash fire.

This difficulty is caused by the total consumption of the available fuel without significantly raising the temperatures of other combustibles. In this case, the fire patterns may be superficial and difficult to trace to any specific point of ignition as in Figure 4.19.2. In addition, separate areas of burning from pocket fuel gas may exist and further confuse the tracing of fire spread.

FIGURE 4.19.2 Blistering of varnish on door and slight scorching of draperies, the only indications of the natural gas flash fire.

4.20 Material Distortion. Patterns can be seen in the physical change of shape and distortion of some objects that are subjected to the heat of the fire.

4.20.1 Distorted Light Bulbs. Incandescent light bulbs can sometimes show the direction of heat impingement. As the side of the bulb facing the source of heating is heated and softened, the gases inside a bulb of greater than 25 watts can begin to expand and bubble out the softened glass. This has been traditionally called a *pulled* light bulb, though the action is really a response to internal pressure rather than a pulling. The bulged or pulled portion of the bulb will be in the direction of the source of the heating, as shown in Figure 4.20.1.

FIGURE 4.20.1 A typical “pulled” bulb showing that the heating was from the right side.



Because they contain a vacuum, bulbs of 25 watts or less can be pulled inward on the side in the direction of the source of heating.

Often these light bulbs will survive fire extinguishment efforts and can be used by the investigator to show the direction of fire travel. In evaluating a distorted light bulb, the investigator should be careful to ascertain that the bulb has not been turned in its socket by prior investigators or fire service personnel.

4.20.2 Metal Construction Elements. Studs, beams, columns, and the construction components that are made of high-melting-point metals, such as steel, can be distorted by heating. The higher the coefficient of thermal expansion of the metal, the more prone it is to heat distortion. The amount and location of distortion in a particular metal construction can indicate which areas were heated to higher temperatures or for longer times. (See Section 4.9.) In some cases, elongation of beams can result in damage to walls, as shown in Figure 4.20.2.

FIGURE 4.20.2 Damage to an outside brick wall caused by thermal expansion of an I-beam in the basement.



Chapter 5 Building Systems

5.1 Introduction. Understanding the reaction of buildings and building assemblies to fire is of prime importance to the fire investigator. Development, spread, and control of a fire within a structure often depends on the type of construction, the ability of structural elements to remain intact, and the interface of fire protection and other building systems. Interior layout, occupant circulation patterns, interior finish materials, and building services can be important factors in the start, development, and spread of the fire. This chapter will assist the investigator to specifically track and document building systems as related to the fire.

It should be noted that this chapter only highlights general building information. Included in the reference section are a number of related texts that will provide the investigator with the opportunity to obtain greater detail and understanding on building construction and building systems. More detailed information can be found in the 18th edition of the NFPA *Fire Protection Handbook*.

In addition to building design and construction elements, there are important fuel-oriented considerations for the fire investigator. For example, during the preflashover, growth stage of a fire the heat release rate of a fuel package has a significant influence on the rate of fire growth. (See Section 3.5.)

5.2 Features of Design, Construction, and Structural Elements in Evaluating Fire Development.

5.2.1 General. The architectural design of a building has a significant influence on its fire safety capabilities. Interior layout, circulation patterns, interior finish materials, and building services are all important factors in fire safety. How the building design affects manual suppression of fires is another important consideration.

The way a fire develops and spreads can be influenced by the building design in the way that the structure is planned, shaped, built, and by the materials chosen. The nature of the occupancy or purpose to which the structure is used can also affect the way it burns. The investigator must evaluate the fire development and spread in light of the knowledge that how the building is formed can influence these factors.

Changes in occupancy types may create a hazard to fire-fighting efforts and may have an effect on the development of the fire. As an example, there can be an ordinary retail business that is then converted to a paint store that is deemed to be a hazardous occupancy. The increased fuel load will most probably affect fire intensity and spread, and the original design may be insufficient to withstand the fire.

5.2.2 Building Design. Fire spread and development within a building is largely the effect of radiant and convective heating. In compartment fires, much of the fire spread is also a function of the state of confinement of heated upper gas layers. For a given fuel package, room size, room lining material, shape, ceiling height, and the placement and areas of doors and windows can profoundly affect the formation of ceiling jets, radiation feedback, the production and confinement of upper gas layers, ventilation, flameover, and the time to flashover of a compartment fire. All of these factors influence how a fire develops.

Compartmentation is a primary fire protection concept. Keeping fire confined in its room of origin and minimizing smoke movement to other areas of a building have long been goals of fire protection engineering designers and fire code organizations. The design of fire-resistive constructions, fire-stopped

pipe chases and utility openings in fire walls, and construction techniques that minimize smoke and flame movement can aid in effective compartmentation. Designs that are less fire safe have just the opposite effect.

Extreme architectural designs such as atriums; large enclosed areas like stadiums or tunnels; and glass or unusual structural, wall, ceiling, roof, or finish materials also pose interesting considerations for the fire investigator, especially in the analysis of the way these features have affected fire growth and spread.

Most of these aspects are initially under the control of the building architect or systems designers. Small changes in the specifications for a structure can have profound effects on the overall fire safety of the building. When necessary and possible, the fire investigator should review design plans and fire code requirements for that structure. Modifications to structural and nonstructural areas of the building may change the fire-resistive capability of the building. For example, existing ceilings that have added drop-down ceilings create a void and may have significant impact on the fire and smoke travel.

5.2.2.1 Building Loads. The effects of undesigned loads, such as added dead and live loads, wind, water, and impact loads, may change the structural integrity of the building. Dead loads are the weight of materials that are part of a building, such as the structural components, roof coverings, and mechanical equipment. Live loads are the weight of temporary loads that need to be designed into the weight-carrying capacity of the structure, such as furniture, furnishings, equipment, machinery, snow, and rain water. Snow on the roof is an example of a live load; an additional layer of roofing is an example of a dead load. The function of a building's structure is to resist forces. As long as these forces remain in balance, the building will stand, but when the balance is lost the building may collapse. Building loads may become unbalanced when a building is subjected to fire and the structural components of the structure are damaged.

5.2.2.2 Room Size. For a given fuel package, that is, heat release rate, the room's volume, ceiling height, size of the ventilation opening, and location of the fire will affect the rate of fire growth in the room. The speed of development of a hot gas upper layer, and the spread of a ceiling jet from the fire plume are among the important factors that determine if and when the room will flash over. Flashover, in turn, has a great effect on the spread of fire out of the room of origin.

The ignition and burning of a fuel load in the room produce heat, flame, and hot gases at a given rate. The area and volume of the room affect the time to flashover: the smaller the area and volume of the room, the sooner the room may flash over and the sooner the fire may spread outside the room, provided all other variables remain constant. Extremely large rooms may never have a sufficient heat energy transfer to cause flashover.

5.2.2.3 Compartmentation. The common mode of fire spread in a compartmented building is through open doors, unenclosed stairways and shafts, unprotected penetrations of fire barriers, and non-fire-stopped combustible concealed spaces. Even in buildings of combustible construction, the common gypsum wallboard or plaster on lath protecting wood stud walls or wood joist floors provides a significant amount of resistance to a fully developed fire. When such barriers are properly constructed and maintained and have protected openings, they normally will contain fires of maximum expected severity in light-hazard occupancies. Even a properly designed, constructed, and maintained

barrier will not reliably protect against fire spread indefinitely. Fire can also spread horizontally and vertically beyond the room or area of origin and through compartments or spaces that do not contain combustibles. Combustible surfaces on ceilings and walls of rooms, stairways, and corridors, which in and of themselves may not be capable of transmitting fire, will be heated and produce pyrolysis products. These products add to those of the main fire and increase the intensity and length of flames. Fire spread rarely occurs by heat transfer through floor/ceiling assemblies. Fire spread through floor/ceiling assemblies may occur in the later stages of fire development or through breaches of these assemblies.

The investigator will want to analyze the reasons that compartmentation of the fire failed or did not occur and which aspects of the design of the building may have been responsible for this failure.

5.2.2.4 Concealed and Interstitial Spaces. Concealed and other interstitial spaces can be found in most buildings. These spaces can create increased rates of fire spread and prolonged fire duration. Both of these factors aggravate the damage expected to be encountered.

Interstitial spaces in a high-rise building are generally associated with the space between the building frame and interior walls and the exterior facade, and with spaces between ceilings and the bottom face to the floor or deck above. These spaces may lack fire stops, the lack of which aids in the vertical spread of fire. Those spaces provided with fire stops should be examined to determine the type of fire stopping provided, if any.

Fire investigators should consider the impact of concealed spaces when they conduct a fire investigation. Failure to consider the effects of fire travel through concealed spaces may lead to misreading the fire patterns. Care must be taken when examining areas such as attics, roofs, and lowered ceilings in rooms that can conceal fire and smoke until the fire is out of control.

5.2.2.5 Planned Design as Compared to "As-Built" Condition. The investigator should be aware that building specifications, plans, and schematic drawings, prepared before construction are not always the "as-built" condition. After permit issuance or on-site inspections, the actual as-built conditions may not always have met the approved design. If necessary or possible, the investigator should verify the actual as-built condition. This verification can be accomplished by an examination of the fire scene, or if this is not possible due to fire damage or the unavailability of the fire scene, by witness interviews.

5.2.3 Materials. The nature of the materials selected and used in a building design can have a substantial effect on the fire development and spread. The nature of material is important from both its physical and chemical properties. How easily the material ignites and burns, resists heating, resists heat-related physical or chemical changes, conducts heat, and gives off toxic by-products are important to an overall evaluation of the design of the structure.

5.2.3.1 Ignitability. How easily a specific material may be ignited, its minimum ignition temperature, minimum ignition energy, and a time-temperature relationship for ignition are basic considerations when the use of the material in a building design is evaluated.

5.2.3.2 Flammability. Once a material is ignited, either in flaming or smoldering combustion, how it burns and transmits its heat energy is also a consideration for the fire investi-

gator. Such factors as heat of combustion, average and peak heat release rate, and perhaps even mass loss rate, can be important considerations in its overall fire safety and suitability for use. The entrainment of air has an important role in the way a fire develops upon the material.

5.2.3.3 Thermal Inertia. The thermal inertia of a material (specific heat \times density \times thermal conductivity) is a key factor in considering the material's reaction to heating and ease of ignition. These factors will need evaluation if the investigator is making determinations about the material's suitability for use or its role in the transition to flashover of a compartment in which the material is a liner.

5.2.3.4 Thermal Conductivity. Good conduction of heat from the surface of the fuel to its interior keeps the surface temperature lower than if it has poor conduction. Conduction impacts the change in temperature of the fuel. Conduction can be the means of transferring heat to the unexposed face of a material, such as a steel partition.

5.2.3.5 Toxicity. Though not directly related to the development and spread of a fire, the toxicity of the products of combustion of a material are a very important consideration in the overall fire safety of a design. Materials that give off large quantities of poisonous or debilitating gases or products of combustion can incapacitate or kill fire victims long before any heat or flames reach them. Toxicity is an important issue for fire investigators involved in evaluating how the design and condition of a building, building materials, and contents affected the occupants. In most fire situations, carbon monoxide is the dominant toxic species. This is particularly true of fire products produced in a flashed-over space.

5.2.3.6 Physical State and Heat Resistance. At what temperature the material under scrutiny changes in phase from solid to liquid or liquid to gas may be a factor in evaluating its fire performance. In general, liquids require less energy to ignite than solids, and gases require still less energy than liquids.

Characteristics of plastics, such as whether they are thermoplastics (which transform from solids to liquids and then to ignitable gases) or thermoset plastics (which pyrolyze directly to ignitable gases), may affect whether they are selected as a structural or surface material.

Materials that tend to melt and liquefy during the course of a fire may be more likely to cause fall-down damage or ignitable liquid fire spread. The choice of such materials in the design of a structure could become important considerations to the fire investigator.

5.2.3.7 Attitude, Position, and Placement. Many materials burn differently, depending upon their attitude, position, or placement within a building. Generally, materials burn more rapidly when they are in a vertical rather than horizontal position. For example, carpeting that is designed and tested to be used in a horizontal position, in full contact with a horizontal flat surface, may burn at a rate well below the maximum standard set by code. When the same carpet material is mounted vertically as a wall covering or curtain, its flammability rating will often be exceeded. An adhesive may have an effect on the burning rate of the carpet.

Flame spread ratings, commonly used in codes and standards to quantify the flammability of a material, often rely upon the ASTM E 84, *Standard Test Method for Surface Burning Characteristics of Building Materials*, often called the Steiner Tunnel Test. The Steiner Tunnel Test burns a sample of the

material in a horizontal attitude, suspended on the ceiling of the 24-foot long Steiner Tunnel. Many of the materials tested in the Steiner Tunnel are not designed or intended to be applied in building designs as ceiling coverings. The actual flame spread of the material as used in construction is often different and might bear no real relationship to its ASTM E 84 rating. For similar materials ASTM E 84 usually will rank order them in terms of flame spread. This generalization breaks down if the tested material rapidly falls from the ceiling, as occurs with foam thermoplastic materials like polystyrene or thin film materials.

5.2.4 Occupancy. When considering how the building elements affected the way in which a fire developed and spread, the investigator should consider whether the occupancy was acceptable for the design and condition of the building. A change in the occupancy of a building can produce much greater fire loads, ventilation effects, total heats of combustion, and heat release rates than originally expected. For example, a warehouse that was originally designed to store automotive engine parts will have a totally different reaction to a fire if the occupancy is changed to the high-rack storage of large quantities of ignitable liquids. The original design may have been adequate for the first fuel load, but inadequate for the subsequent fuel load with its increased hazard.

5.2.5 Computer Fire Model Survey of Building Component Variations. In analyzing the effects of building design upon the development, spread, and ultimate damage from a fire, the use of computer fire models can be very helpful. Through the use of models, the investigator can view the various effects of a number of design variables. By modeling differing building design components, the investigator can see how the changes in a component can change the computed development and growth of the fire.

5.2.6 Explosion Damage. The amount and nature of damage to a building from an explosion is also affected by the design of the structure. The stronger the construction of the exterior or interior confining walls, the more a building can withstand the effects of a low-pressure or slow rate-of-pressure-rise explosion. Conversely, the more brisant or demolishing damage will result from a high-pressure or rapid rate-of-pressure-rise explosion. The shape of the explosion-confining room can also have an effect on the resulting damage. See Chapter 18 on explosions for more information.

In a low order explosion, the more windows, doors, or other available vents within the confining structure, the less structural damage will be sustained.

5.3 Types of Construction. The following discussion concerning the types of construction is based on the methods of construction and materials rather than the descriptions used in classification systems of the model building codes. When necessary, the fire investigator should obtain the building construction classifications and descriptions that are a part of the particular building code that is enforced in the jurisdiction in which the fire occurred and should use them as a part of the scene documentation. For further detail, the investigator is directed to the NFPA *Fire Protection Handbook*.

The investigator should document the types of construction by looking at the main structural elements. Documentation may include main structural components, breaches, structural changes, or other factors that may influence structural integrity or fire spread.

5.3.1 Wood Frame. Wood frame construction is often associated with residential construction and contemporary lightweight commercial construction. Buildings with wood structural members and a masonry veneer exterior are considered wood frame. Lightweight wood frame construction is usually used in buildings of limited size. Floor joists in such construction are normally spaced 16 in. (406 mm) on center, and the vertical supports are often nominal 2 in. by 4 in. (50.800 mm by 101.600 mm) or nominal 2 in. by 6 in. (50.800 by 152.400 mm) wall-bearing studs, again spaced 16 in. (406 mm) on center. Wood frame construction has little fire resistance because flames and hot gases can penetrate into the spaces between the joists or the studs, allowing fire spread outside of the area of origin. (See 4.16.1.3.) Wood frame construction is classified as Type V construction, as defined in NFPA 220, *Standard on Types of Building Construction*.

Wood frame construction can be sheathed with a fire-resistant membrane (e.g., gypsum board, lath and plaster, mineral tiles) to provide up to 2-hour fire resistance when tested in accordance with ASTM E 119, *Standard Methods of Tests of Fire Endurance of Building Construction and Materials*. Such high fire resistances in frame construction are unusual but may be encountered in special occupancies such as one- or two-story nursing homes.

5.3.1.1 Platform Frame Construction. Platform frame construction is the most common construction method currently used for residential and lightweight commercial construction. In this method of construction, separate platforms or floors are developed as the structure is built. The foundation wall is built; joists are placed on the foundation wall; then a subfloor is placed. The walls for the first floor are then constructed, with the ceiling joists placed on the walls. The rafter, ridge-pole, or truss construction methods are used for the roof assembly. An important fire concern other than the fact that combustible materials are used in construction is that there are concealed spaces in soffits and other areas for fire to spread without detection.

Platform construction inherently provides fire barriers to vertical fire travel as a result of the configuration of the stud channels. However, these barriers in wood frame construction are combustible and may be breached over the course of the fire allowing the fire to spread to other spaces. Vertical fire spread may also occur in platform construction through utility paths, such as electrical, plumbing, and HVAC. Openings for utilities in wall stud spaces may allow easy passage of the fire from floor to floor.

5.3.1.2 Balloon Frame. In this type of construction, the studs go from the foundation wall to the roofline. The floor joists are attached to the walls by the use of a ribbon board, which creates an open stud channel between floors, including the basement and attic. This type of construction is typical in many homes built prior to 1940.

Almost all building codes have for many years required fire stopping of all vertical channels in balloon frame construction. Where fire stopping is present, buildings of balloon frame construction respond to fire similarly to buildings of platform frame construction. Fire stopping can be in the form of wood boards or by filling of the void space with noncombustible materials, historically with brick or dirt, and more recently with insulation. Where such fire stops were not installed or later removed (typically to install a utility such as wiring, HVAC, or other services), balloon frame construction provides unobstructed vertical channels, in concealed spaces

behind interior finish, for rapid undetected vertical fire spread. Rapid fire spread and horizontal extension is further enhanced by the open connections of the floor joists to the vertical channels. Fire can spread upward to other floors or attic spaces and horizontally through floor spaces. Balloon frame construction will also allow fall down from above to ignite lower levels. Fire originating on lower levels can extend into the open vertical channels and may break out in one or more floors above where the fire originated. There can be more extensive burning at the upper level than where the fire originated. This result may be recognized by the attic fire that consumes the top of the structure while the fire actually originated at some lower level.

5.3.1.3 Plank and Beam. In plank and beam framing, a few large members replace the many small wood members used in typical wood framing; that is, large dimension beams more widely spaced (4 in. by 10 in. or 5 in. by 12 in. on 4 ft or 6 ft centers) replace the standard floor and/or roof framing of smaller dimensioned members (2 in. by 8 in. or 2 in. by 10 in. joists or rafters on 16 in. centers). The decking for floors and roofs is planking in minimum thickness of 2 in., as opposed to $\frac{1}{2}$ in., $\frac{5}{8}$ in., or $\frac{3}{4}$ in. plywood sheathing. Instead of 2 in. by 4 in. bearing partitions supporting the floor or roof joist or rafter systems, the beams are supported by posts. There is an identifiable skeleton of larger timbers that are visible. Generally there is only a limited amount of concealed spaces to allow a fire to spread. This method of construction is often thought of as the ancestor to modern high-rise construction, as the major load-bearing portion of the structure is frame and the rest is filler. The exterior veneer finish is of no structural value. Most planks will be tongue and groove, which will slow the progress of the fire.

This type of construction provides for larger spans of unsupported finish material than does framed construction. This property may result in failure of structural sections with large frame members still standing. Interior finishes in these constructions often have large areas of exposed, combustible construction surface that may allow flame spread over its surface.

5.3.1.4 Post and Frame. Post and frame construction is similar to plank and beam construction in that the structure utilizes larger elements, and the frame included is provided to attach the exterior finish. An example of this construction is a barn, with the major support coming from the posts, and the frame providing a network for the exterior finish to be applied.

5.3.1.5 Heavy Timber. Heavy timber is a construction type in which structural members, that is, columns, beams, arches, floors, and roofs, are basically of unprotected wood, solid or laminated, with large cross-sectional areas (8 or 6 in. in the smallest dimension depending on reference). No concealed spaces are permitted in the floors and roofs or other structural members, with minor exceptions. Floor assemblies are frequently large joists and matched lumber flooring (2 in. thick tongue and groove usually end matched).

When the term *heavy timber* is used in building codes and insurance classifications to describe a type of construction, it includes the requirement that all bearing walls, exterior or interior, be masonry or other 2-hour rated noncombustible materials. (See 5.3.3.) Many buildings have heavy timber elements in combination with other materials such as smaller dimension wood and unprotected steel.

Contemporary log homes use specially milled logs for the exterior walls and for many of the structural elements. The remainder of the construction is usually nominal 2 in. by 4 in. (50.800 mm by 101.600 mm) wood frame construction. Open

spans and spaces and large areas of combustible interior finish are common to this type of construction. Due to the interior finish, wood frame components, and open spaces, fire spread may be rapid. The rapid spread and failure frequently appears in conflict with the timber walls and structural elements that often remain standing.

5.3.1.6 Alternative Residential Construction. While wood frame site-built is traditionally associated with residential construction, there are other forms and materials being utilized.

5.3.1.6.1 Manufactured Homes (Mobile Homes). A manufactured home is a structure that is transportable in one or more sections and that, in the traveling mode, is 8 ft (2.4 m) or more in width and 40 ft (12.2 m) or more in length or, when erected on site, is 320 ft² (29.7 m²) or more. This structure is built on a permanent chassis (frame) and designed to be used as a dwelling with or without a permanent foundation when connected to the required utilities. In the U.S., since June 15, 1976, a manufactured home must be designed and constructed in accordance with 24 *CFR* 3280, "Manufactured Home Construction and Safety Standards (HUD Standard)."

Manufactured homes consist of four major components or subassemblies: chassis, floor system, wall system, and roof system. The chassis is the structural base of the manufactured home, receiving all vertical loads from the wall, roof, and floor, and transferring them to stability devices that may be piers or footings or to a foundation. The chassis generally consists of two longitudinal steel beams, braced by steel cross members. Steel outriggers cantilevered from the outsides of the main beams bring the width of the chassis to the approximate overall width of the superstructure. The floor system consists of its framing members, with sheet decking glued and nailed to the joists, fiberglass insulation blankets installed between the joists, and a vapor barrier sealing the bottom of the floor. Ductwork and piping are often installed longitudinally within the floor system. The floor finish is generally carpeting, resilient flooring, linoleum, or tile.

In newer HUD Standard homes, exterior siding is metal, vinyl, or wood on wood studs, and interior surfaces of exterior walls are most often gypsum wallboard. In older, pre-HUD Standard homes, walls are typically wood studs with aluminum exterior siding, and combustible interior wall surfaces are usually wood paneling.

The roof system in HUD Standard homes consists of either the framed wood roof rafter and ceiling joist system or a wood truss system. Roof decking is generally oriented strand board or plywood attached to the top of the roof rafters or trusses. Finished roofing is often composition shingles. In newer HUD Standard units, gypsum wallboard may be attached directly to the bottom of the ceiling joists or to the bottom chords of the trusses. Blown rock wool or cellulose insulation or insulation blankets provide the roof insulation. In older, pre-HUD Standard homes, exterior roofing is often galvanized steel or aluminum. Interior ceiling surfaces may be combustible material or gypsum wallboard.

Steel tie plates reinforce connections between wall and floor systems. Diagonal steel strapping binds the floors and roof into a complete unit.

Older units that consist of metal exteriors and interiors of wood paneling may experience fires of greater intensity and rapidity than fires in site-built single family structures. The short burn-through time of the walls and ceiling results in quick involvement of the stud walls and the roof supports and decking. These units tend to have smaller rooms that may

result in greater fuel load per cubic foot than generally exist in other housing. The exterior metal shell results in increased radiation heat feedback after it is exposed to an interior fire. Metal roofing nominally prevents auto vertical ventilation that results in greater fire involvement.

In newer homes, the use of gypsum wallboard on walls and ceilings, reduced flame spread ratings of materials around heating and cooking equipment, and mandatory smoke detectors, where maintained and operable, tends to result in fire incidents similar to those seen in traditional site-built homes of wood frame construction. In older, pre-HUD Standard units, combustible interior finish ignition of combustible materials adjacent to heating and cooking equipment and lack of smoke detectors are among identified fire problems.

5.3.1.6.2 Modular Homes. A modular home is constructed in a factory and placed on a site-built foundation, all or in part, in accordance with a standard adopted, administered, and enforced by the regulatory agency, or under reciprocal agreement with the regulatory agency, for conventional site-built dwellings.

5.3.1.6.3 Steel Frame Residential Construction. Many builders today are adopting steel framing for residential building. As cold-formed steel construction is becoming more prevalent in residential building, the model building codes are addressing the structural and fire safety characteristics of steel framing. Steel framing has many similarities to conventional wood framing construction. Steel framing methods are available for site-built (balloon or platform), panelized, and pre-engineered systems. Steel, like masonry construction, is noncombustible; however, steel framing can lose its structural capacity under severe exposure to heat. Tests have demonstrated that exposed steel beams and joists that may exist in unfinished spaces may fail in periods as short as 3 minutes during flash-over fire conditions.

5.3.1.7 Manufactured Wood Structural Elements. Laminated timbers will behave similarly to heavy timbers until the heat of the fire begins to affect the structural stability adversely. If failure occurs, the investigator should document the overall dimensions of the beam as well as the dimensions of the glued pieces. Laminated beams are like heavy timber because their mass will remain and support loads longer than dimension lumber and unprotected steel beams. Laminated beams are generally designed for interior use only. The effects of weather may decrease the load-bearing capabilities of the beam and should be considered if the beam has been exposed to water or other similar conditions.

Wood "I beams" are constructed with small dimension or engineered lumber, as the top and bottom chord, with oriented strand board or plywood as the web of the beam. Newer floor joist assemblies can be made totally of laminated top and bottom chords with "chip" plywood. These members are generally thinner than the floor joists and typical structural members they replace. As a result, burn-through of the web and resulting failure can occur more quickly than is generally predicted with the use of dimensional lumber. Also increasing the rate of web burn-through is the use of fabricated lumber, such as plywood and oriented strand board, which may have adhesive failure, causing delamination and disintegration. The failure can cause early collapse of floor/ceiling assemblies. Breaches in the web for utilities may allow for fire spread through the spaces and result in earlier failure. Unlike wood trusses, wood I beams will confine fire to the joist space for a period of time.

Wood trusses are similar to trusses of other materials in their general design and construction. The truss members are often fastened using nail or gusset plates. The gussets can lead to earlier failure than burn-through of the members. This failure occurs because the metal gussets conduct heat rapidly into the wood, causing charring, and because the actual fastening penetrating tines are short. The charring causes the wood to "release" the gusset, leading to collapse of the truss. Failure of one truss will induce loads on adjacent trusses that may lead to a rapid collapse.

5.3.2 Ordinary Construction. The difference between ordinary and frame construction lies mostly with the construction of the exterior walls. In frame construction, the load-bearing components of the walls are wood. In ordinary construction, the exterior walls are masonry or other noncombustible materials. The interior partitions, floor, and roof framing are wood assemblies and, in general, utilize either the platform or braced framing methods. Ordinary construction is classified as Type III construction as defined in NFPA 220, *Standard on Types of Building Construction*.

There are a number of factors that affect fire spread in this type of construction, including combustible materials and open vertical shafts. In addition to these items, there may be many other factors that can influence fire spread, including multiple ceilings, utility penetrations, structural failure, and premature collapse.

5.3.3 Mill Construction. Mill construction is a type of heavy timber construction where there are only beams and no girders so that the span of the floor is one bay. This creates small bays in the building but produces a strong resistance to ignition and an extended ability to maintain its load and to resist burn-through during fire. Semi-mill construction is similar but produces larger bays through the utilization of both beams and girders. Semi-mill buildings have a strong resistance to burn-through and have the ability to maintain their load-carrying capability during fire conditions, though the capability is usually considered a little less than that of full mill construction.

5.3.4 Noncombustible Construction. Noncombustible construction is principally used in commercial, industrial, storage, and high-rise buildings. The major structural components are noncombustible. The major feature of interest in noncombustible construction is that the structure itself will not add fuel to the fire and will not directly contribute to fire spread. Noncombustible construction may or may not be fire-resistive construction, although all construction has some inherent fire resistance.

Brittle materials, such as brick, stone, cast iron, and unreinforced concrete, are strong in compression but weak in tension and shear. Columns and walls, but not beams, can be constructed of these materials. Ductile materials such as steel will deform before failure during fire conditions. If this is in the elastic range of the member, it will resume its previous shape with no loss of strength after the load is removed. If it is in its plastic range, the member will be permanently deformed, but may continue to bear the load. In either event, elongation or deformation can produce building collapse or damage.

5.3.4.1 Metal Construction. Exposed steel beams and joists typically exist in unfinished spaces. These exposed elements have been shown by test to fail in as little as 3 minutes in a typical flashed-over fire exposure.

The structural elements used in noncombustible construction are primarily steel, masonry, and concrete. Wrought-iron

elements can be encountered in older buildings, and copper and alloys such as brass and bronze are used primarily in decorative rather than load-bearing applications. Aluminum is rarely encountered as a structural element, although it is used in curtain wall construction and as siding in both combustible and noncombustible construction. Aluminum will melt at a temperature well below those encountered in fires. A consideration with aluminum and steel is that they may conduct electricity when an electrical fault comes in contact with the metal. This conduction may result in what appears to be a secondary point of origin. Concrete and masonry will generally absorb more heat than steel because these materials require more mass to obtain the necessary strength relative to steel. Concrete and masonry are good thermal insulators, so they do not heat up quickly and do not transfer heat quickly into or through them. Steel is a good conductor of heat, so it will absorb heat and transfer heat much faster than masonry or concrete.

Steel will lose its ability to carry a load at much lower temperatures than will concrete or masonry and will fail well below temperatures encountered in a fire. Steel structural elements can distort, buckle, or collapse as a result of fire exposure. Wrought iron will withstand higher temperatures than steel but even wrought iron columns can distort when exposed to building fires. The susceptibility of a steel structural element to damage in a fire depends on the intensity and duration of the fire, the size of the steel element, and the load carried by the steel element.

Although all construction assemblies have some inherent fire resistance, fire-rated assemblies are types that have been tested under specific procedures established for hourly fire ratings. Fire resistance ratings may refer to a structural system's ability to support a load during a fire or to prevent the spread of a fire. Fire resistance ratings are determined on the basis of a specific test and will not necessarily indicate how long a system will perform in any actual fire.

5.3.4.2 Concrete or Masonry Construction. Other major construction materials include concrete and masonry. These materials have an inherent resistance to effects from fire due to their mass, high density, and low thermal conductivity.

Concrete and masonry are found in many forms and applications. Masonry assemblies and concrete have high strength in compression and relatively low strength in tension. Consequently, both need reinforcement for tensile strength.

Fireground failures in these types of materials generally relate to reinforcement failure and failure in the connection between components. Reinforcement failure can result from heat transfer through the concrete or masonry, or from surface spacing and exposure of the reinforcement to the fire temperatures. Connections generally are made of steel, and their failures occur at temperatures well within the range found in structure fires.

5.4 Construction Assemblies. *Assemblies*, as used in this chapter, can be described as a collection of components, such as structural elements, to form a wall, floor/ceiling, or other. Components may be assemblies such as doors that form a part of a larger complete unit. The way assemblies react in a fire often influences how the fire grows and spreads, as well as how they maintain their structural integrity during the fire. Assemblies are often interdependent, and failure of one may contribute to failure of another.

Assemblies may or may not be fire resistance rated; however, most assemblies will provide some resistance to fire. It also should be noted that most assemblies are not rated for

smoke penetration with the exception of smoke control dampers. Scene documentation should include what was there for later comparison with applicable code requirements.

An assembly without a rating means that we do not know what the standard fire tests would indicate, given the failure time under the test fire conditions.

Assemblies are rated for a specific fire test criterion and under test conditions. The actual fire conditions found in the structure may be more severe and may cause the assembly to fail at a time that is actually less than the hourly rating assigned as a result of the fire test. Failure of an assembly in and of itself is not an indicator of the cause of the fire; however, it is appropriate to determine the circumstances associated with the failure of the assembly.

When assemblies are evaluated after a fire, consideration should be given to any local deficiency of a component in the overall assembly, such as a hole in the wall, missing tiles in a ceiling, or even a door blocked open.

5.4.1 Floor/Ceiling/Roof Assemblies. Floor/ceiling assemblies fail in a number of ways, including collapse, deflection, distortion, heat transmission, or penetration of fire allowing vertical fire spread. Failure depends on a number of factors, including the type of structural elements; the protection of the elements; and span, load, and beam spacing. Rated floor assemblies are tested for fire exposure from below and not from above. There are limited experimental data for fires burning downward, which can occur in a number of mechanisms such as hot layer radiation or drop down. Live loads and water weight can contribute to the collapse of floors and ceilings.

Penetrations are regularly found in floor/ceiling assemblies. Penetrations are often used to provide access for utilities, HVAC systems, plumbing, computer data and communication, and other functions. Penetrations in fire-rated floor/ceiling assemblies are required to be sealed to maintain the rating. Unsealed penetrations facilitate the passage of fire and smoke through the floor/ceiling assembly.

Roof assemblies affect structural stability during the fire rather than the resistance to the spread of the fire. Roofs can have a major impact on the fire dynamics if the roof fails in a fire.

5.4.2 Walls. Walls perform a number of fire safety-related functions, the most obvious of which is compartmentation, which tends to limit fire spread. Compartment walls are constructed to various standards, ranging from nonrated partitions to self-supporting parapeted fire walls.

Walls may or may not be fire rated and rated walls may or may not be load bearing. Also, load-bearing walls may be fire rated even though their function is not to stop the spread of fire. The fire wall will not be effective if it is not continuous through the ceiling and attic section of the structure.

A fire wall is a wall separating buildings or subdividing a building to prevent the spread of fire and having a fire resistance rating and structural stability.

A fire barrier wall is a wall, other than a fire wall, having a fire resistance rating. Fire walls and fire barrier walls do not need to meet the same requirements as smoke barriers.

Smoke barriers are continuous membranes, either vertical or horizontal, such as a wall, floor, or ceiling assembly, designed and constructed to restrict the movement of smoke. A smoke barrier might or might not have a fire resistance rating. Such barriers might have protected openings.

Penetrations are regularly found in wall assemblies. The penetrations often are used to provide access for doors, utilities, HVAC systems, plumbing, computer data and communication,

and other functions. Penetrations in fire-rated wall assemblies are required to be sealed to maintain the rating. Unsealed penetrations facilitate the passage of fire and smoke through the wall assembly, allowing the fire to spread horizontally.

A fire barrier wall is not required to be constructed of non-combustible materials. Fire barrier walls constructed of combustible materials include the use of wood studs with type X gypsum board on the exterior surfaces. Where the structure has a load-bearing party wall assembly, combustible materials can again be used. In this instance, there are two separate stud walls built; the exterior finish is gypsum board; between the two stud walls plywood is attached; and there is an air space between the walls. Most requirements for a fire barrier wall will have type X on both sides of the wall to make it fire resistive.

There are a number of other walls found in structures. While these walls have not been subjected to fire tests in order to be rated, they will still provide some resistance to the spread of fire within a building.

5.4.3 Doors. Doors may be a key factor in the spread of fire. Doors can be made of a variety of materials and be fire rated or non-fire rated. It should be noted that if there is a door opening in a fire-rated wall or partition, it would be required to be provided with an appropriate fire-rated door, installed as an entire assembly. Fire-rated door assemblies are required to include rated frames, hinges, closures, latching devices, and if provided (and allowed), glazing. Fire doors may be of wood, steel, or steel with an insulated core of wood or mineral material. While some doors have negligible insulating value, others may have a heat transmission rating of 250°F, 450°F, and 650°F (121°C, 232°C, and 343°C). This means the doors will limit temperature rise on the unexposed side to that respective value when exposed to the standard time-temperature for 30 minutes. This insulating value aids egress, particularly in stairwells in multistory buildings, and provides some protection against autoignition of combustibles near the opening's unexposed side. In addition to the rating of the door, to be effective in limiting the spread of fire from one compartment to another, the door must be closed. The position of doors can change during and after a fire for a variety of reasons, including automatic closure systems, personnel movement, and fire suppression activities.

5.4.4 Concealed Spaces. Concealed spaces are inaccessible areas of a structure such as the interstitial space above a ceiling, below a floor, soffits, or between walls. Attics are not considered to be concealed spaces because they are accessible. Concealed spaces provide a hidden path for fire to grow or spread without being identified early in the event. By the time fire moves out of the concealed space, it often has already spread extensively throughout the structure. Fires in concealed spaces are difficult to extinguish. Concealed spaces are found in almost all types of construction and may have built-in fire protection features such as sprinklers, barriers, and automatic detection. The presence, performance, or absence of these protective features may have a dramatic effect on progression of the fire. For those concealed spaces identified as noncombustible, all components, materials, or equipment used in the construction of the concealed space must be of noncombustible or fire-resistive assemblies, or must have been provided with listed fire-protective coating. Concealed spaces normally classified as noncombustible may still contain some combustible materials such as fire-retardant-treated lumber, communications and power wiring cable, and plastic pipe. Fires can still start and spread in concealed spaces that are classified as noncombustible.

Chapter 6 Electricity and Fire

6.1 Introduction. This chapter discusses the analysis of electrical systems and equipment. The primary emphasis is on buildings with 120/240-volt, single-phase electrical systems. These voltages are typical in residential and commercial buildings. This chapter also discusses the basic principles of physics that relate to electricity and fire.

Prior to beginning an analysis of a specific electrical item, it is assumed that the person responsible for determining the cause of the fire will have already defined the area or point of origin. Electrical equipment should be considered as an ignition source equally with all other possible sources and not as either a first or last choice. The presence of electrical wiring or equipment at or near the origin of a fire does not necessarily mean that the fire was caused by electrical energy. Often the fire may destroy insulation or cause changes in the appearance of conductors or equipment that can lead to false assumptions. Careful evaluation is warranted.

Electrical conductors and equipment that are used appropriately and protected by properly sized and operating fuses or circuit breakers do not normally present a fire hazard. However, the conductors and equipment can provide ignition sources if easily ignitable materials are present where they have been improperly installed or used. A condition in the electrical wiring that does not conform to the NFPA 70, *National Electrical Code*[®], might or might not be related to the cause of a fire.

6.2 Basic Electricity.

6.2.1 The purpose of this section is to present basic electrical terms and concepts briefly and simply in order to develop a working understanding of them.

6.2.2 Water flowing through a pipe is familiar to everyone. This phenomenon has some similarities to electrical current flowing in an electrical system. Because of these similarities, a limited comparison between a hydraulic system and an electrical system can be used to understand an electrical system.

6.2.3 Table 6.2.3 shows the basic elements of a hydraulic system along with the corresponding elements of an electrical system.

6.2.4 In a hydraulic system, a pump is used to create the hydraulic pressure necessary to force water through pipes. In an electrical system, a generator is used to create the necessary electrical pressure to force electrons through a conductor. This electrical pressure is voltage. The amount of hydraulic pressure is expressed in pounds per square inch (psi) and can be measured with a pressure gauge. The amount of electrical pressure is expressed in volts and is measured with a voltmeter.

6.2.5 In the hydraulic system, it is water that flows in a useful way. In the electrical system, it is electrons that flow in a useful way. This flow is called electrical current. The amount of water flow is expressed in gallons per minute (gpm) and may be measured with a flowmeter. The amount of electrical current is expressed in amperes (A) and may be measured with an ammeter. Electric current can be either direct current (dc), such as supplied by a battery, or alternating current (ac), such as supplied by the electric utility companies.

Table 6.2.3 Elements of Hydraulic and Electrical Systems Compared

Elements of a Hydraulic System	Elements of an Electrical System
Pump	Generator
Pressure	Voltage (potential or electromotive force)
Pounds per square inch (psi)	Volts (V)
Pressure gauge	Voltmeter
Water	Electrons
Flow	Current
Gallons per minute (gpm)	Amperes (A)
Flowmeter	Ammeter
Valve	Switch
Friction	Resistance (ohms)
Friction loss	Voltage drop
Pipe size — inside diameter	Conductor size — AWG No.

6.2.6 Direct current flows in only one direction, as in a circulating water system, while alternating current flows back and forth with a specific frequency. In the United States, the frequency of 60 hertz, or 60 cycles per second, is used. For the majority of applications encountered in this text, it is satisfactory to visualize ac circuits as if they were the more easily understood dc circuits. Notable exceptions include transformers and many electric motors that will not work on direct current. In addition, three-phase circuits and single-phase circuits that are not principally resistive cannot be analyzed in the same way as direct current circuits or common single-phase ac circuits. The specific differences between the behavior of alternating current versus direct current are beyond the scope of this document.

6.2.7 The water pipe provides the pathway for the water to flow. In the electrical system, conductors such as wires provide the pathway for the current.

6.2.8 In a closed circulating hydraulic system (as opposed to a fire hose delivery system where water is discharged out of the end), water flows in a loop, returning to the pump, where it is circulated again through the loop. When the valve is closed, the flow stops everywhere in the system. When the valve is opened, the flow resumes. An electrical system must be a closed system, in that the current must flow in a loop or in a completed circuit. When the switch is turned on, the circuit is completed and the current flows. When the switch is turned off, the circuit is opened and current flow stops everywhere in the circuit. This voltage drop is called potential or electromotive force, as shown in Figure 6.2.8.

6.2.9 Friction losses in pipes result in pressure drops. Electrical friction (i.e., resistance) in conductors and other parts also results in electrical pressure drops or voltage drops. To express resistance as a voltage drop, Ohm's law must be used. (*See 6.2.13.*)

When electricity flows through a conducting material, such as a conductor, a pipe, or any piece of metal, heat is generated. The amount of heat depends on the resistance of the material through which the current is flowing and the amount of current. Some electrical equipment, such as a heating unit, is designed with appropriate resistance to convert electricity to heat.

FIGURE 6.2.8 Typical components of water and electrical systems.

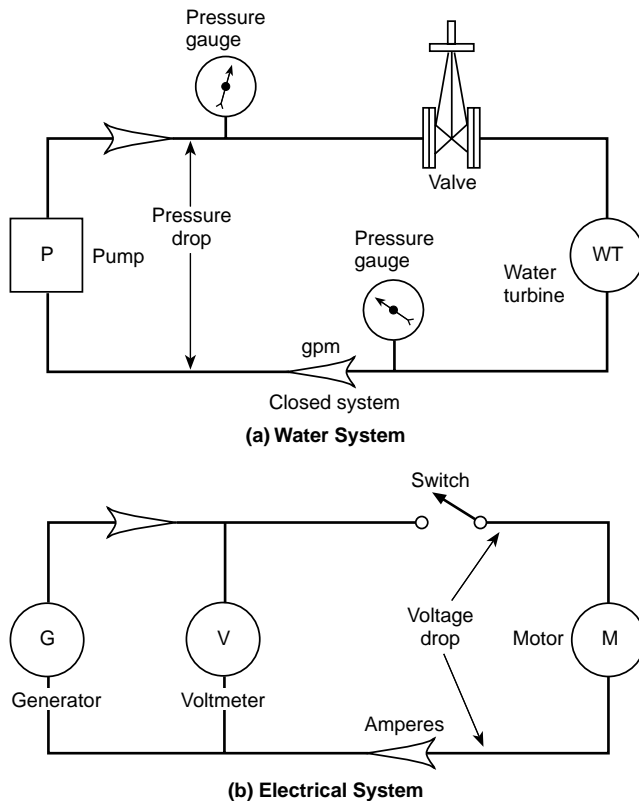

6.2.10 The flow of water in a pipe at a given pressure drop is controlled by the pipe size. A larger pipe will allow more gallons per minute of water to flow than will a smaller pipe at a given pressure drop. Similarly, larger conductors allow more current to flow than do smaller conductors. Conductor sizes are given American Wire Gauge (AWG) numbers. The larger the number, the smaller the conductor diameter. Small conductors, such as No. 22 AWG, are used in telephone and other signal circuits where small currents are involved. Larger conductors, such as Nos. 14, 12, and 10 AWG, are used in residential circuits. The larger the diameter (and hence the larger the cross-sectional area) of the conductor, the lower the AWG number and the less the resistance of the conductor. This means that a No. 12 AWG copper conductor will be allowed to conduct a larger current than a smaller No. 14 AWG copper conductor. (See Figure 6.2.10.)

FIGURE 6.2.10 Conductors. American Wire Gauge (AWG) sizes, diameters of cross sections, and resistance of conductors commonly found in building wiring.

Solid Copper Wire		Resistance in ohms per 1000 ft (305 m) at 158°F (70°C)
	Diameter	
14 AWG	● .064 in. (1.63 mm)	3.1
12 AWG	● .081 in. (2.06 mm)	2.0
10 AWG	● .102 in. (2.60 mm)	1.2

6.2.11 The ampacity of a conductor is the current in amperes a conductor can carry continuously under the conditions of use without exceeding its temperature rating. This depends on the ambient temperature the conductor is operating in as well as other factors, such as whether the conductor is in conduit with other conductors carrying similar current, alone, or in free air, and so forth. For example, Table 310.16 of NFPA 70, *National Electrical Code*, lists the ampacity of No. 8 AWG copper conductor with TW insulation (moisture-resistant thermoplastic) as 40 amperes. This rating is based on an ambient temperature of 86°F (30°C) and on being installed in a conduit or raceway in free air containing no more than three conductors. Any changes — such as more conductors in a raceway, higher ambient temperature, or insulation around the conduit — that reduce the loss of heat to the environment will decrease the ampacity. This same size conductor is rated at 50 amperes with THWN insulation (moisture- and heat-resistant thermoplastic); the THWN insulation has a temperature rating of 167°F (75°C) compared to 140°F (60°C) for the TW insulation. The temperature rating of the insulation is the maximum temperature at any location along its length that the conductor can withstand for a prolonged period of time without serious degradation.

The ampacity values for a conductor depend on the heating of the conductor caused by the electric current, the ambient temperature that the conductor is operating in, the temperature rating of the insulation, and the amount of heat dissipated from the conductor to the surroundings. Current passing through an aluminum conductor generates more heat than the same current passing through a copper conductor of the same diameter; the ampacity of an aluminum conductor is less than that for the same size copper conductor. Also, the ampacity of a conductor is reduced when it is operated at an elevated temperature or when it is covered with a material that provides thermal insulation. Conversely, the actual ampacity of a single conductor in open air or in a conduit will be higher than that given in the tables. The actual as-used ampacity may be an important consideration in evaluating the cause of electrical faulting.

A safety factor is included in ampacity values. Simply demonstrating that ampacity has been exceeded does not mean the fire had an electrical ignition source.

6.2.12 Some conductor materials conduct current with less resistance than do other materials. Silver conducts better than copper. Copper conducts better than aluminum. Aluminum conducts better than steel. This means that a No. 12 AWG copper conductor will have less resistance than the same size No. 12 AWG aluminum conductor. There will be less heat generated in a copper conductor than in an aluminum conductor for the same current and AWG size.

6.2.13 Ohm's law states that the voltage (see Figure 6.2.13) in a circuit is equal to the current multiplied by the resistance, or

$$E = I \times R$$

where:

E = voltage

I = current

R = resistance

FIGURE 6.2.13 Ohm's law in a simple circuit.

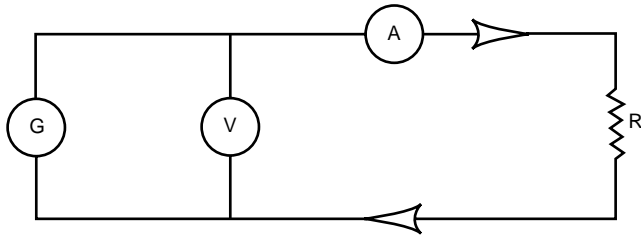

$$R \text{ (resistance)} = \frac{V}{I} \left[\frac{\text{voltage}}{\text{amperage}} \right]$$

$$V \text{ (voltage)} = I \text{ (amperage)} \times R \text{ (resistance)}$$

$$I \text{ (amperage)} = \frac{V}{R} \left[\frac{\text{voltage}}{\text{resistance}} \right]$$

Voltage (E) is measured in volts, current (I) is measured in amperes, and resistance (R) is measured in ohms.

Using this simple law, the voltage drop can be found if the current and resistance are known. Rearranging the terms, we can solve for current if voltage and resistance are known:

$$\text{current} = \frac{\text{voltage}}{\text{resistance}} \quad \text{or} \quad \text{amperes} = \frac{\text{volts}}{\text{ohms}}$$

Also, resistance can be found if the current and voltage are known:

$$\text{resistance} = \frac{\text{voltage}}{\text{current}} \quad \text{or} \quad \text{ohms} = \frac{\text{volts}}{\text{amperes}}$$

A voltmeter and an ammeter can be used to determine the resistance. If the resistance and the voltage can be measured, the amperage can be calculated.

6.2.14 When electrons are moved (electrical current) through a resistance, electrical energy is spent. This energy may appear in a variety of ways such as light in a lamp or heating of a conductor. The rate at which energy is used is called power. The amount of power is expressed in watts (W). A 100 W lightbulb generates more light and heat than a 60 W lightbulb. (See Figure 6.2.14.)

FIGURE 6.2.14 The power, in watts (P), consumed by a lightbulb, a product of the current (I) squared and the resistance (R) of the lightbulb.

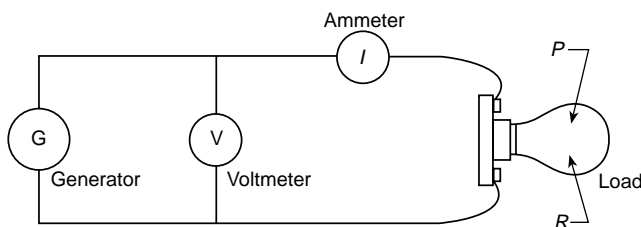

Energy may be expressed in many different ways. For electrical applications, energy is usually measured in watt-seconds or watt-hours. A watt-second is equal to 1 joule, and a watt-hour is equal to 3600 joules (3.413 Btu).

6.2.15 Power in electrical systems (P) is measured in watts. Resistive appliances such as a hair dryer or lightbulb are rated in watts. Power is computed as shown in the Ohm's law wheel, in Figure 6.2.15. The relationships among power, current, voltage, and resistance are important to fire investigators because of the need to find out how many amperes were drawn in a specific case. See Figure 6.2.15 for a summary of these relationships. If, for example, several appliances were found plugged into one extension cord or many appliances were plugged into several receptacles on the same circuit, the investigator could calculate the current draw to find whether the ampacity of the conductor was exceeded.

FIGURE 6.2.15 Ohm's law wheel for resistive circuits.

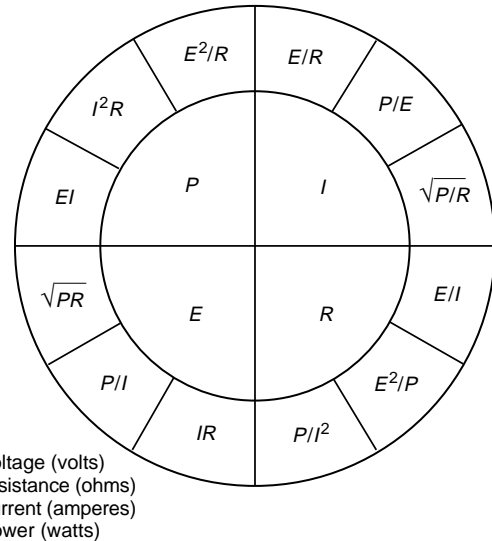

For example, a hair dryer designed to operate on 120 volts draws 1500 watts:

$$\text{current } (I) = \frac{\text{power } (P)}{\text{voltage } (E)} = \frac{1500 \text{ watts}}{120 \text{ volts}} = 12.5 \text{ amperes}$$

$$\text{resistance } (R) = \frac{\text{voltage}^2 (E^2)}{\text{power } (P)} = \frac{120^2 \text{ volts}}{1500 \text{ watts}} = 9.6 \text{ ohms}$$

To check results, do the following computation:

$$\text{volts } (E) = I \times R = 12.5 \times 9.6 = 120 \text{ V}$$

$$\text{watts} = (I)^2 \times R = (12.5)^2 \times 9.6 = 1500 \text{ W}$$

6.2.16 The following example will show how to find the total amperes, assuming the heater and circuit protection are turned on and are carrying current. A portable electric heater and cooking pot are plugged into a No. 18 AWG extension cord. The heater is rated at 1500 W and the cooking pot is 900 W. The previous relationships showed that current equaled power divided by voltage.

$$\begin{aligned} \text{amperes } (I) &= \frac{\text{watts } (P)}{\text{volts } (V)} \quad \text{or} \quad \frac{1500}{120} \\ &= 12.5 \text{ A for the heater} \end{aligned}$$

$$\begin{aligned} \text{amperes } (I) &= \frac{\text{watts } (P)}{\text{volts } (V)} \quad \text{or} \quad \frac{900}{120} \\ &= 7.5 \text{ A for the pot} \end{aligned}$$

The total amperage of a circuit is the sum of the amperage of each device that is plugged into the circuit. The total amperage for a circuit consisting of three receptacles is the total amperage of all devices plugged into these receptacles. Similarly, the total amperage on an extension cord is the sum of the amperage of each device plugged into the extension cord.

In the example illustrated in Figure 6.2.16, the calculated amperages were 12.5 and 7.5, so the total amperage of that extension cord when both appliances were operating was $12.5 + 7.5 = 20.0$ A. Tables of allowable ampacities [from NFPA 70, *National Electrical Code*, Table 400.5(a)] show that the maximum current should be 10 A in the No. 18 AWG extension cord. Therefore, the cord was carrying an overcurrent. The question to be determined is whether this created an overload. Did the overcurrent last long enough to cause dangerous overheating? In a situation such as shown in Figure 6.2.16, where it appears an overload existed, it is necessary to show that these conditions will create enough temperature rise to cause ignition. An overload is not absolute proof of a fire cause. If an overload occurred, this cord could be considered as a possible ignition source, particularly if the heat was confined or trapped, such as under a rug or between a mattress and box spring, preventing dissipation.

A similar situation exists when a short circuit occurs by conductor-to-conductor contact. This is by definition a connection of comparatively low resistance. As seen by Ohm's law, when the resistance goes down, the current goes up. Although a short circuit does cause a large current flow, the circuit overcurrent protection devices normally prevent this current from flowing long enough to cause overheating of the conductors.

6.3 Building Electrical Systems.

6.3.1* General. This section provides a description of the electrical service into and through a building. It is intended to assist an investigator in recognizing the various devices and in knowing generally what their functions are. The main emphasis is on the common 120/240 V, single-phase service with limited information on three-phase and higher voltage service. This section does not provide detailed information on codes. That information should come from the appropriate documents.

6.3.2 Electrical Service.

6.3.2.1 Single-Phase Service. Most residences and small commercial buildings receive electricity from a transformer through three conductors, either overhead from a pole or underground. The two insulated conductors, called the hot legs or phases, have their alternating currents flowing in opposite directions (reversing 120 times per second for 60-cycle power) so that they go back and forth at the same instant but in opposite directions (180 out of phase). This alternating current is called single phase. The third conductor is grounded to serve as the neutral conductor, and it may be uninsulated. The voltage between either of the hot conductors and the grounded conductor is 120 V, as shown in Figure 6.3.2.1(a). The voltage between the two hot conductors is 240 V. The incoming conductors are large multi-stranded cables intended to carry large currents safely. As

illustrated in Figure 6.3.2.1(b), they all may hang separately, or the two hot conductors may be wrapped around the neutral in a configuration called a triplex drop.

FIGURE 6.2.16 Total current calculation.

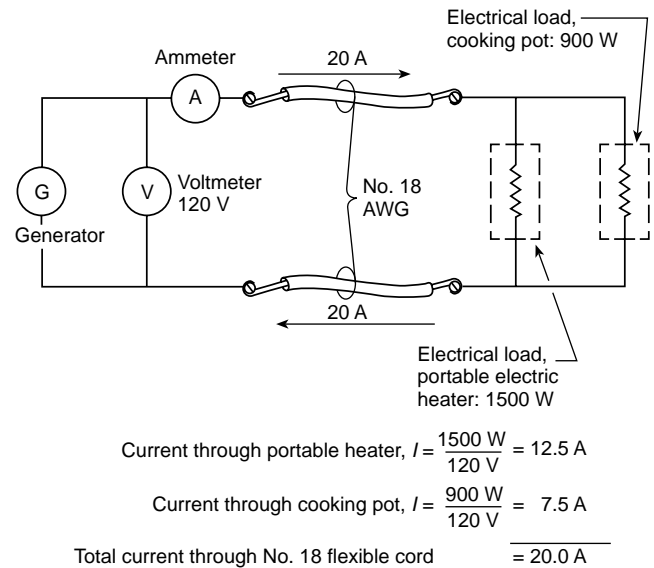

FIGURE 6.3.2.1(a) Relation of voltages in 120/240 V service.

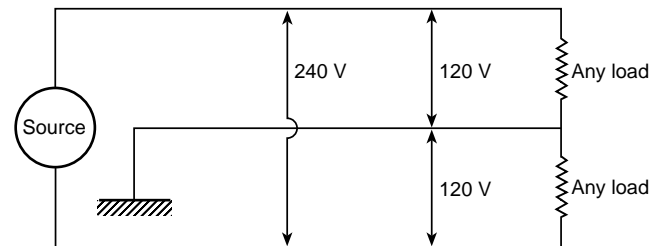
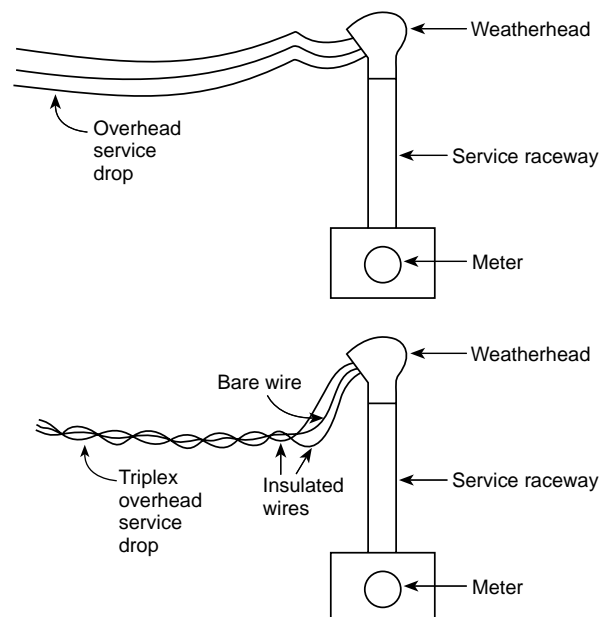
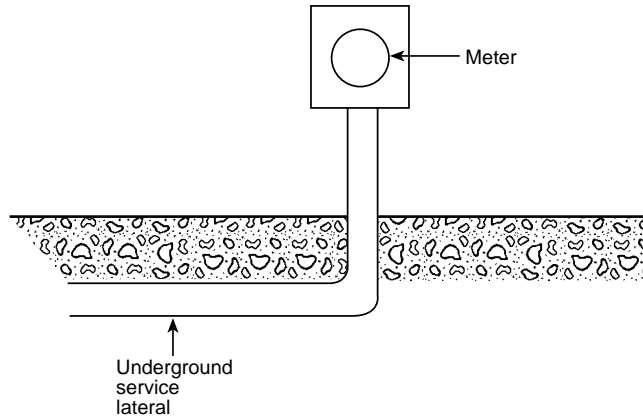

FIGURE 6.3.2.1(b) Overhead service.



If the cables come from a transformer on a pole, they are called a service drop. If they come from a transformer in or on the ground, they will be buried and are called a service lateral. [See Figure 6.3.2.1(c).]

FIGURE 6.3.2.1(c) Underground service.



The terms *hot*, *neutral*, and *ground* will usually be used in this document for installed conductors. The proper terms for them are *ungrounded*, *grounded*, and *grounding*, respectively.

6.3.2.2 Three-Phase Service. Industrial and large commercial buildings, large multifamily dwellings, and other large buildings normally are supplied with three-phase electrical service. Three-phase service consists of three alternating currents that go back and forth at different instants (out of phase with one another). There will be three current-carrying conductors and usually a fourth, which is the neutral and is at ground potential. The voltage between current-carrying conductors is typically 480 V, 240 V, or 208 V. The voltage between the conductors and ground depends on the wiring arrangement and may be 277 V, 208 V, or 120 V. The 480/277 V four-conductor system is a common service for large commercial and industrial buildings. Modern lighting systems in these buildings commonly operate at 277 V. In very large buildings, there might be more than one electrical service entrance. In some industrial buildings, the service entrance voltage may be very high (e.g., 4000 V). Transformers within buildings then reduce the voltage for utilization, including 120 V for lights and receptacles.

6.3.3 Meter and Base. The cables of a service drop go into a weatherhead, which is designed to keep water from entering the system, and then down a service raceway to a meter base. A watt-hour meter plugs into the meter base and connects the service cables so that electricity can flow into the structure. In newer structures, the meter base is normally mounted on the outside. Cables go from the meter base to the service equipment in the structure, as shown in Figure 6.3.3. In larger facilities, the entry cables may be connected directly to the service equipment without passing through the meter. In that case, the meter is operated from current transformers that surround each entry cable and sense current flow.

FIGURE 6.3.3 Service entrance and service equipment.

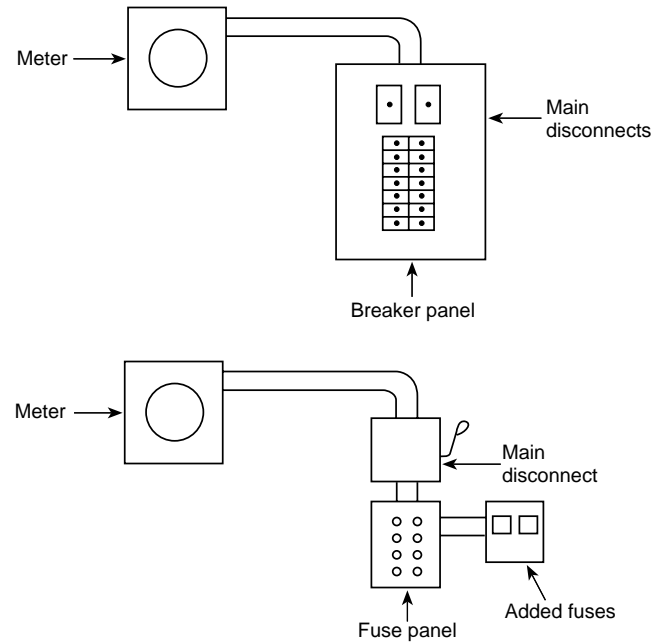

6.3.4 Significance. The service entry can be significant in fire investigations because damage to the insulation on the conductors can result in sustained high-power faulting by either short circuits or ground faults that can ignite most combustibles. Between the utility transformer and the main protection in the structure, there is usually no overcurrent protection of the cables, and faulting may begin and continue. Once there are fault currents, either causing a fire or resulting from a fire, continued faulting can damage all or part of a service entrance.

6.4 Service Equipment. The cables from the meter base go to the service equipment, which consists of a main switch and fuses or circuit breakers. (See Figure 6.3.3.) The service equipment must be located close to where the cables enter the structure. The service equipment has three functions: to provide means for turning off power to the entire electrical system, to provide protection against electrical malfunctions, and to divide the power distribution into several branch circuits. Either a main switch or the main circuit breakers are the primary disconnects that can shut off all electricity to the building. From the cabinet of fuses or circuit breakers, electricity is distributed through branch circuits to the rest of the building.

6.5 Grounding. All electrical installations must be grounded at the service equipment. Grounding is a means of making a solid electrical connection between the electrical system and the earth. Grounding is accomplished by bonding the breaker or fuse panel to a metallic cold water pipe if the pipe extends at least 10 ft (3.0 m) into soil outside. In the absence of a suitable metallic cold water pipe, a grounding electrode must be used. The grounding electrode may be a galvanized steel rod or pipe or a copper rod of at least 8 ft (2.4 m) in length driven into soil to a level of permanent moisture.

In all installations, the service equipment must be bonded to the cold water piping. Bonding is the connecting of items of equipment by good conductors to keep the equipment bodies at the same voltage, which is essentially zero if bonded

to ground. Bonding of the service equipment to ground is accomplished by a copper or aluminum conductor from the grounding block in the fuse or breaker cabinet to a clamp that is securely fixed to the cold water pipe or grounding electrode. An example is shown in Figure 6.5. The purpose of grounding an electrical system is to make sure that any housings or exposed metal objects in the system or connected to it cannot become electrically charged. If an ungrounded conductor (the hot conductor) contacts a grounded object, the resulting surge of ground-fault current will open the protection.

FIGURE 6.5 Grounding at a typical small service. A, B, and C are bonding connections that provide a path to ground.

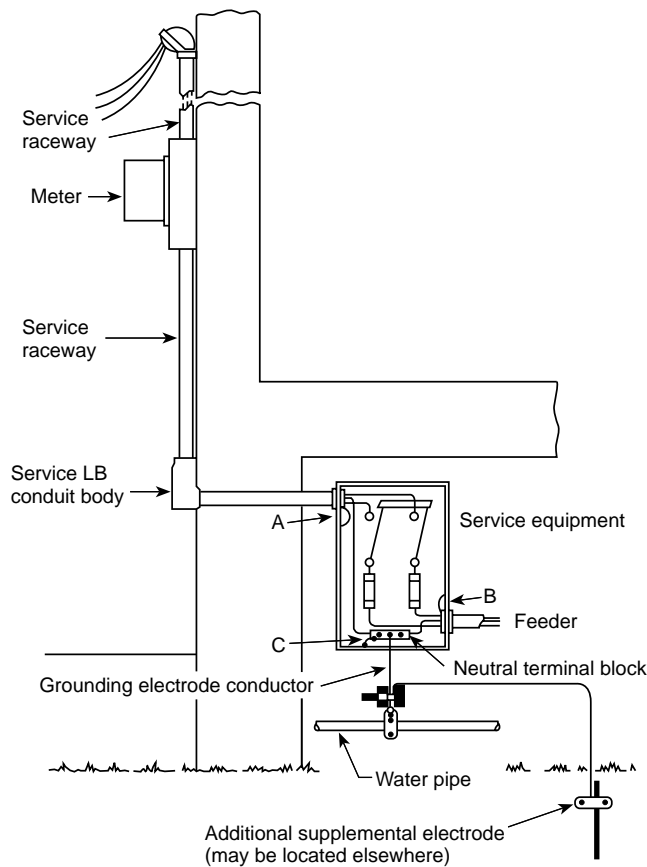

All parts of the system must be grounded, including cabinets, raceways, fittings, junction and outlet boxes, switches, receptacles, and any conductive objects attached to or plugged into the system. That is usually accomplished with a grounding conductor that accompanies the circuit conductors, although grounding can be accomplished through metallic conduit. Flexible metallic conduit may be used for grounding only if its length does not exceed 6 ft (1.8 m).

6.5.1 Floating Neutral. An electrical installation that is not properly grounded can continue to be used, but there will not be a fixed zero point of voltage (ground) between the two legs. There will still be 240 V between the two legs, but instead of the voltages of the two legs being fixed at 120 V to ground each, they may vary to some other values that add to 240 V. (See Figure 6.5.1.) All line to neutral circuits will be

affected. The actual voltages in the legs will depend on the loads on the two legs at any particular time. For example, the voltages might be 60 and 180 as in Figure 6.5.1. The higher voltage can overheat or burn out some equipment, and the lower voltage can damage some electronic equipment. Occupants would have seen incandescent lights that were too bright or too dim or appliances that overheated or malfunctioned in some way.

FIGURE 6.5.1 An example of the relation of voltages in 120/240 V services with an ungrounded neutral.

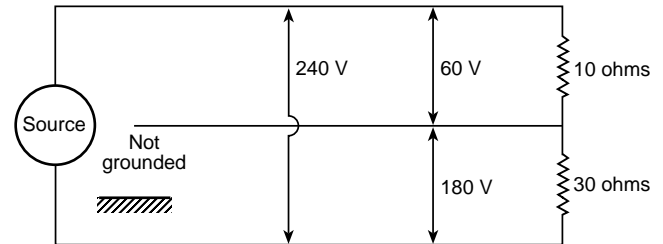

6.6 Overcurrent Protection. Fuses and circuit breakers provide protection against electrical short circuits, ground faults, and load currents that might be damaging (i.e., overloads). In general, such an overcurrent device must be installed where each ungrounded (hot) branch conductor is connected to the power supply, and the device must function automatically. Overcurrent devices are attached to bus bars in cabinets that are mounted in or on a wall. Examples are shown in Figures 6.6(a), 6.6(b), 6.6(c), and 6.6(d).

Protective devices have two current ratings, the regular current rating and the interrupting current rating. The regular rating is the level of current above which the device will open, such as 15 A, 20 A, or 50 A. The interrupting rating is the level of current that the device can safely interrupt. A common value for circuit breakers is 10,000 A.

FIGURE 6.6(a) Fuse panel.

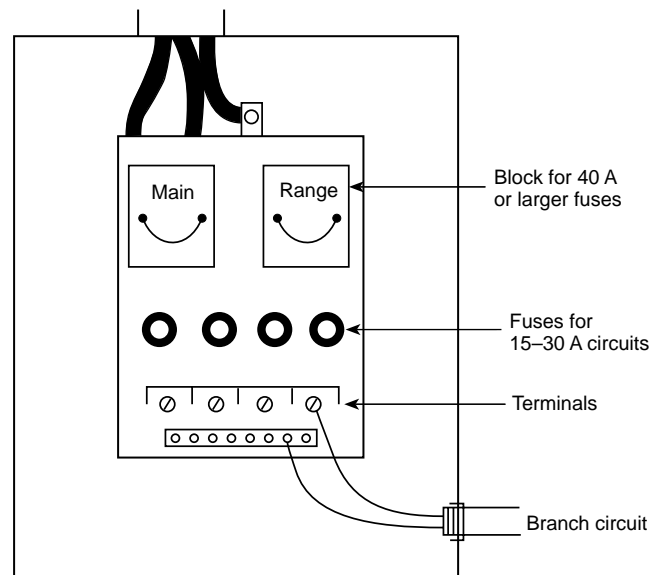

FIGURE 6.6(b) Common arrangement for a circuit-breaker panel.

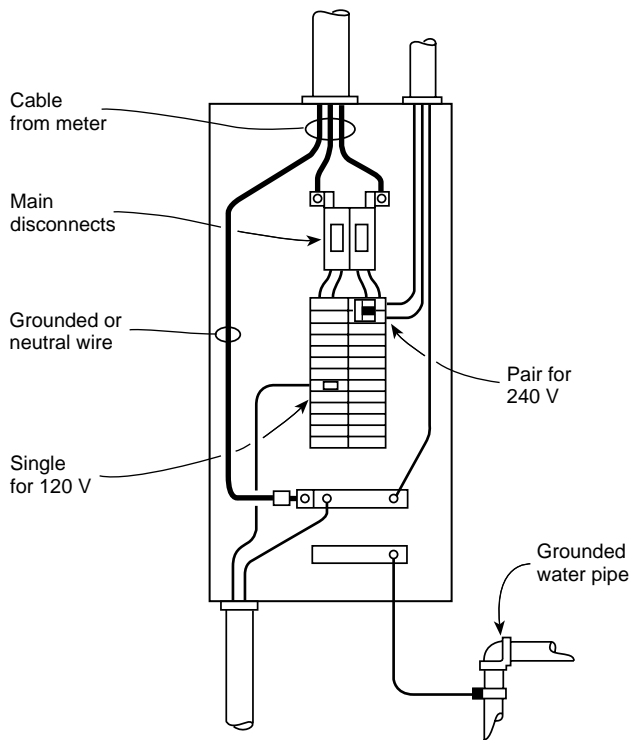

FIGURE 6.6(d) Circuit-breaker panel.

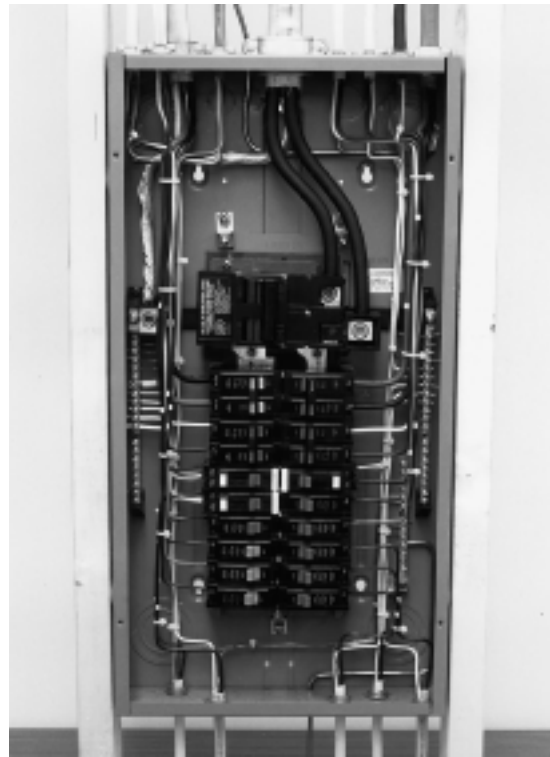
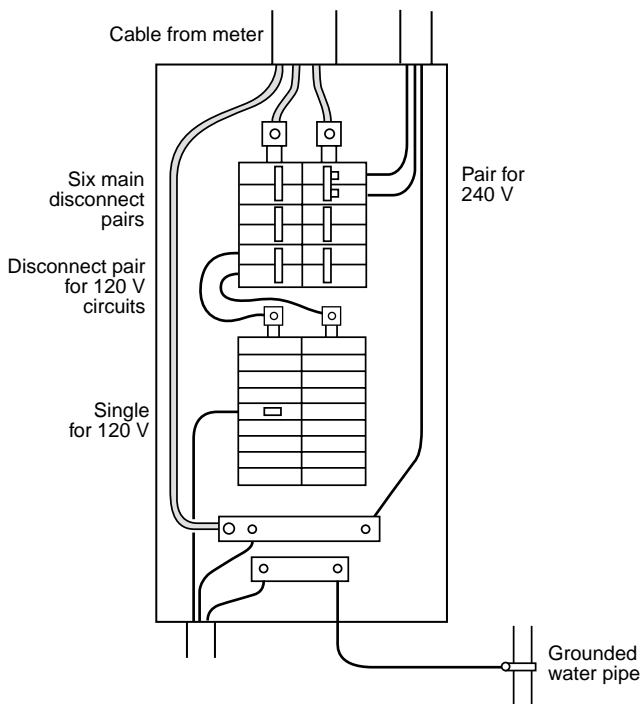

FIGURE 6.6(c) Common arrangement for a split-bus circuit-breaker panel.



6.6.1 Fuses. Fuses are basically nonmechanical devices with a fusible element in a small enclosure. The fusible element is made of a metal conductor or strip with enough resistance so that it will heat to melting at a selected level of current. Fuses have essentially no mechanical action; they operate only on the electrical and physical properties of the fuse element. Some fuses may contain a spring to help the separation of the fuse element on melting. Dual element fuses contain one element that operates most effectively with overloads and the other element that operates most effectively with short circuits. Ordinary fuses are single-use, but some large fuses have replaceable elements. There are two types of fuses: the plug type that screws into a base and the cartridge type that fits into a holder. They are shown in Figures 6.6.1(a), 6.6.1(b), and 6.6.1(c). Fuses are not resettable.

FIGURE 6.6.1(a) A typical, Edison-based nonrenewable fuse, single element, for replacement purposes only.



FIGURE 6.6.1(b) Another Edison-based nonrenewable fuse, dual element, for replacement purposes only.

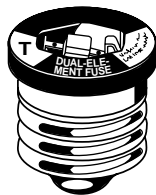
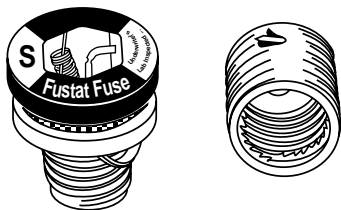

FIGURE 6.6.1(c) A Type S nonrenewable fuse and adapter. The time-lag type of fuse is acceptable but not required.



Fuses are mounted in a panel board consisting of bus bars, connecting lugs, fuse holders, and supporting structures. Residential installations will usually be a combination of plug fuses for circuits of 30 A or less and cartridge fuses in removable holders for fuses with regular ratings greater than 30 A. The interrupting ratings on non-time-delay fuses are in the order of 100,000 A because they clear the fault in less than one-half cycle.

6.6.1.1 Plug Fuses. For circuits intended for 30 A or less, plug-type fuses have been used. The fuses have Edison bases so that all ampacities will fit in the same base. Thirty-ampere fuses could be put in where only 15 A fuses had been intended. Because of that overfusing and the ease with which the fuses could be bypassed (e.g., with a penny), they are not allowed in new installations. Such fuses are still available for replacement of burned-out fuses in existing installations.

6.6.1.2 Type S Fuses. In an effort to minimize improper fusing, Type S fuses were developed. They are designed to make tampering or bypassing more difficult. They screw into adapters that fit into Edison bases. After an adapter has been properly installed, it cannot be removed without damaging the fuse base. The adapter prevents a larger-rated fuse from being used with a lower-rated circuit and makes bypassing the fuse more difficult.

NFPA 70, *National Electrical Code*, specifies that fuse holders for plug fuses of 30 A or less shall not be used unless they are designed to use this Type S fuse or are made to accept a Type S fuse through use of an adapter.

6.6.1.3 Time-Delay Fuses. Whether a fuse is Type S or has an Edison base, the time-delay type of fuse permits overcurrents of short duration, such as starting currents for motors, without opening the circuit. While these momentary surges can be up to six times greater than the normal running current, they are harmless because they last only a short time. This makes it possible to use time-delay fuses in sizes small enough to give better protection than a type without time delay. The latter would have to be oversized to allow for such surges. In the event of short circuits or high-current ground faults, however, the

time-delay type will operate and open the circuit as rapidly as the non-time-delay type. Time-delay fuses can be designed with dual elements or by modification of the fusing element.

6.6.1.4 Cartridge Fuses. For circuits intended for greater than 30 A, cartridge fuses are used. As shown in Figures 6.6.1.4(a) and 6.6.1.4(b), they consist of a cylinder containing the fusing element and either caps or blades on each end to make electrical contact in its holder. Cartridge fuses may be made for either fast action or time delay. They also come in single-use or replaceable-element types. Cartridge fuses may be found in fuse panels of residential installations for high current loads, such as water heaters and ranges, and at the main disconnect. Large fuses of 100 A rating or greater are more common in commercial or industrial installations.

FIGURE 6.6.1.4(a) Three types of cartridge fuses. Top, an ordinary drop-out link renewable fuse; center, a super lag renewable fuse; and bottom, a one-time fuse.

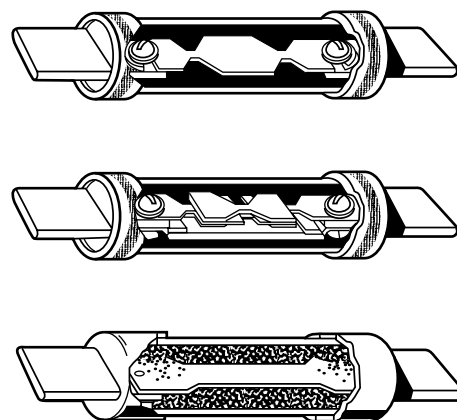
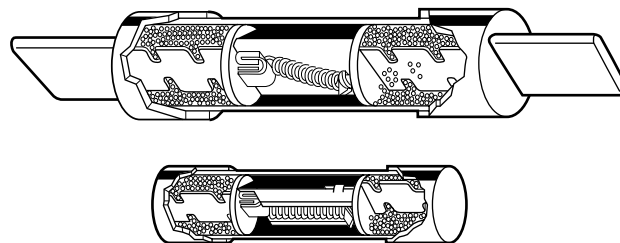

FIGURE 6.6.1.4(b) Dual-element cartridge fuses, blade and ferrule types.



6.6.2 Circuit Breakers. A circuit breaker is a switch that opens either automatically with overcurrent or manually by pushing a handle. The current rating of the breaker is usually, but not always, given on the face of the handle. Breakers are designed so that the internal workings will trip with excessive current even if the handle is somehow held in the on position. The on and off positions are indicated either on the handle or on the body. [See Figures 6.6.2(a) and 6.6.2(b).] The tripped position is in the center on most breakers. [See Figure 6.6.2(c).] Normally, a circuit breaker cannot be manually placed in the tripped position while installed in the panel. However, if the fault has been corrected, it can be reset to the on position each time it has been tripped by overcurrent. A typical interrupting rating for circuit breakers is 10,000 A.

FIGURE 6.6.2(a) A 15 A residential-type circuit breaker in the closed (on) position.

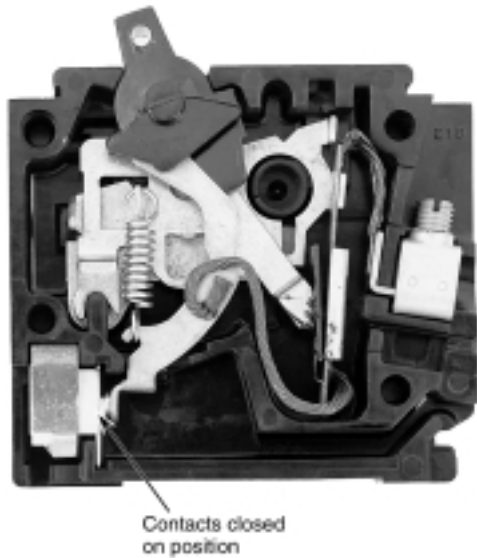

FIGURE 6.6.2(b) A 15 A residential-type circuit breaker in the open (off) position.



Most residential circuit breakers are of the thermal-magnetic type. The thermal element, usually a bimetal, provides protection for moderate levels of overcurrent. The magnetic element provides protection for short circuits and for low-resistance ground faults, during which the fault currents are very high. Circuit breakers are mechanical devices that require movement of their components for operation. It is possible for them to fail to open, especially if they have not been operated either manually or by overcurrent in a long time and especially if they have been in a corrosive atmosphere.

The bodies of circuit breakers are usually made of molded phenolic plastic, which does not melt and does not sustain burning but which can be destroyed by fire impingement. Circuit breakers on a panel board are directly connected to bus bars that are fed from the main disconnect. A cover plate over the rows of breakers exposes only the tops of the breakers so that no energized parts of the panel or wiring are exposed.

FIGURE 6.6.2(c) A 15 A residential-type circuit breaker in the open (tripped) position.



6.6.2.1 Main Breakers. The main disconnect in a breaker panel is a pair of circuit breakers of ampacity large enough to carry the entire current draw of the installation, commonly 100 A to 200 A in residences. The handles of the two breakers (one on each leg) are fastened together or are molded as one unit so that only one motion is needed to turn off both legs. Also, if one leg has a fault that trips the one breaker, the fastener will pull off the other breaker. Three-phase service uses three main breakers in a single body or with the handles fastened together and three bus bars to feed the breakers.

There are many split-bus panel boards in use. [See *Figure 6.6(c)*.] They usually have six 2-pole breakers or pairs of breakers fastened together to make 240 V circuits. All of them must be off to cut off all power to the installation. One of the breaker pairs serves as a main for the lower bus bars that feed the 120 V circuits. Split-bus panel boards are not allowed in new installations.

6.6.2.2 Branch Circuit Breakers. The circuit breakers for individual branch circuits are rated for the maximum intended current draw (ampacity). Circuits of 120 V will be fed from a single breaker, whereas circuits of 240 V will be fed from a double pole breaker or a pair of breakers of equal ampacity with the handles fastened together. General lighting and receptacle circuits will be 15 A or 20 A. Large appliances such as ranges and water heaters will have 30 A, 40 A, or 50 A breakers. Some small permanent appliances might have dedicated circuits with 15 A or 20 A breakers.

Three-phase service uses three bus bars to feed the breakers. Motors and other equipment that use three-phase power will be fed by three branch circuit breakers of equal ampacity with the handles fastened together.

6.6.2.3 Ground Fault Circuit Interrupter (GFCI). On newer installations, a breaker might have a button labeled "push to test." This breaker houses a ground fault circuit interrupter. It trips with a slight ground fault of about 5 milliamperes to give better protection for persons against electric shock at any level of amperage in the circuit. In addition, the breaker operates with overcurrents as an ordinary circuit breaker. The GFCI circuits are intended for bathrooms, patios, kitchens, or other locations where a person might be electrically grounded while near or using electrical appliances.

6.7 Branch Circuits. The individual circuits that feed lighting, receptacles, and various fixed appliances are the branch circuits. Each branch circuit should have its own overcurrent protection. The circuit consists of an ungrounded conductor (hot conductor) attached to a protective device and a grounded conductor (neutral conductor) attached to the grounding block in the cabinet. Both of those conductors carry the current that is being used in the circuit. In addition, there should be a grounding conductor (i.e., the ground). It normally does not carry any current but is there to allow fault current to go to ground and thereby open the protection. Some installations might have the grounding through metallic conduit, and some very old installations might not have a grounding conductor at all. The lack of a separate means of grounding has no effect on the operation of devices powered by that circuit.

6.7.1 Conductors. Conductors in electrical installations usually consist of copper or aluminum because they are economical and good conductors of electricity. Conductors made of other metals for special uses are covered in Chapter 21.

6.7.2 Sizes of Conductors. The sizes of conductors are measured in the American Wire Gauge (AWG). The larger the AWG number, the smaller the conductor. The branch circuit conductors for lighting and small appliances are usually solid copper, 14 AWG for 15 A circuits and 12 AWG for 20 A circuits. Circuits of larger ampacity will have larger conductors such as 10 or 8 AWG, as listed in Table 6.7.2. Conductors of 6 AWG or larger size will be multistranded to give adequate flexibility.

Table 6.7.2 Ampacity and Use of Branch Circuits

Wire Size		Ampacity	Use
Copper	Copper-Clad Aluminum and Aluminum		
14	12	15	Branch circuit conductors supplying other than kitchen
12	10	20-25	Small-appliance circuit conductors supplying outlets in kitchen for refrigerators, toasters, electric frying pans, coffee makers, and similar appliances
10	8	30	Large appliances such as ranges and dryers
8	6	40	
6	4	55	

Aluminum branch wiring has been used and might be found in some installations. Because of problems with heating at the connections, aluminum conductors are not used in branch circuits without approved connectors, although aluminum cables such as 3/0 and 4/0 cables are used for service drops and service entry.

The conductor size allowed in a circuit depends mainly on the ampacity of the protective device. In addition, the type of

insulation and the bundling of conductors affect the allowed sizes. The conductor must not be smaller than the allowed size but may be larger. The basic reason for regulating the allowed size is to prevent heating of the conductor enough to damage its insulation. Because conductors have some resistance, heat will be generated as current passes through them. Small conductors have more resistance than large conductors and so heat more. The NFPA 70, *National Electrical Code*, tables show how much current is allowed in various size conductors with various kinds of insulation.

6.7.3 Copper Conductors. The chemical element copper is used in a pure form to make conductors. The copper is heated and drawn through progressively smaller holes to squeeze it down to the desired size. There is no identifiable crystal structure in such copper. Impurities or alloying elements would make the copper less conductive to electricity. Pure copper melts at 1980°F (1082°C). In fires, copper melts along the surface of the conductor at temperatures somewhat below 1980°F (1082°C) because of mixing of the metal with copper oxide that forms on the surface in air. That is why, when copper conductors melt in a fire, they tend to melt along their surfaces to form pointed ends, globules, and thinned areas.

Copper conductors oxidize in fires when the insulation has been lost. The surface usually becomes blackened with cupric oxide. For some conductors in a chemically reducing condition, such as glowing char before cooling, the surface may appear either to be bare of oxide or to be coated with a reddish cuprous oxide.

6.7.4* Aluminum Conductors. The chemical element aluminum is used in a pure form to make conductors. Pure aluminum melts at 1220°F (660°C). A skin of aluminum oxide forms on the surface, but the oxide does not mix with the metallic aluminum. Therefore, the melting temperature is not reduced, and the aluminum tends to melt through the whole cross section at one time instead of leaving an unmelted core as copper does. Melted aluminum can flow through the skin of oxide and have odd shapes when it solidifies. These shapes include pointed drips, and round and teardrop-shaped globules.

Aluminum has a lower conductivity than does copper. Thus, for the same ampacity of a circuit, an aluminum conductor must be two AWG sizes larger than a copper conductor. For example, 10 AWG aluminum is equivalent in ampacity to 12 AWG copper.

6.7.4.1 Copper-Clad Aluminum. Copper-clad aluminum conductors have been used but are not common. Because they are aluminum conductors with just a skin of copper, their melting characteristics are essentially the same as those of aluminum conductors.

6.7.5 Insulation. Conductors are insulated to prevent current from taking unwanted paths and to protect against dangerous voltages in places that would be hazardous to people. Insulation could be made of almost any material that can be applied readily to conductors, does not conduct electricity, and retains its properties for a long time even at elevated temperatures. For a summary of the types of insulation in use, see Table 310.13 of NFPA 70, *National Electrical Code*. Air serves as an insulator when bare conductors and energized parts are kept separated. At high voltage, air contamination by dust, pollution, or products of combustion can break down the insulating effects of air, resulting in arcs.

The type of insulation on individual conductors is marked in a code, along with the temperature rating, the manufacturer, and other information. Nonmetallic sheathed cable has the identifications printed on the sheath. The coding for the insulation material is given in Table 310.13 of NFPA 70.

Insulation on individual conductors is made in a variety of colors, some of which indicate specific uses. A grounding conductor must be green. A grounded conductor (neutral) may be white or light gray. An ungrounded conductor (hot) may be any color except green, white, or gray. In 120 V circuits it is commonly black. In 240 V circuits with nonmetallic cable, the two hot legs are commonly black and red. Where individual conductors are pulled through the conduit, the colors might vary more widely, especially if more than one circuit is in the conduit.

6.7.5.1 Polyvinyl Chloride. Polyvinyl chloride, or PVC, is a commonly used thermoplastic insulating material for wiring. PVC must be blended with plasticizers to make it soft. Pigments and other modifiers may also be added. PVC, on aging, can slowly lose the plasticizers and become hard and brittle. In a fire, PVC may char and give off hydrogen chloride, a corrosive gas.

6.7.5.2 Rubber. Rubber was the most common insulating material until approximately the 1950s. Rubber insulation contains pigments and various modifiers and antioxidants. In time it may become oxidized and brittle, especially if it was hot for long periods. Embrittled rubber has little strength and can be broken off the conductor if it is bent or scraped. Rubber insulation chars when exposed to fire or very high temperatures and leaves an ash when the rubber is burned away.

6.7.5.3 Other Materials. Polyethylene and other closely related polyolefins are used as insulation, more commonly on large cables than on insulation for residential circuits. Nylon jackets are put around other insulating materials (usually PVC) to increase the thermal stability of the insulation.

Silicone and fluorinated polyolefin (e.g., Teflon®) insulations are used on conductors that are expected to be installed where elevated temperatures will persist, particularly in appliances.

6.8 Outlets and Devices.

6.8.1 Switches. Switches are installed to turn the current on or off in parts of circuits that supply installed lights and equipment. Sometimes one or more receptacles are fed from a switch so that a table lamp can be turned on or off. The hot (black) conductor goes to both terminals of the switch while the neutral (white) conductor goes on to the light or device being controlled. The switch should always be put in the run of the black conductor for safety, although the switch will perform properly if put in the run of the white conductor. The switches may have screw terminals or push-in terminals.

6.8.2 Receptacles. Receptacles for 15 A and 20 A circuits, illustrated in Figures 6.8.2(a) and 6.8.2(b), are usually duplex. Receptacles for large appliances (30 A or more) are single. Receptacles now must be polarized and of the grounding type, although there are still many nongrounding and nonpolarized receptacles in older installations. The grounding type has a third hole that allows any appliance with a grounding prong in its plug to ground that appliance. In polarized receptacles, the neutral slot is longer than the hot slot. A two-prong plug with a wide neutral prong (polarized plug) can be inserted into the receptacle only with the wide prong in the wide slot

and not in the reverse way. All grounding receptacles and plugs are inherently polarized.

FIGURE 6.8.2(a) Nongrounding-type receptacle.

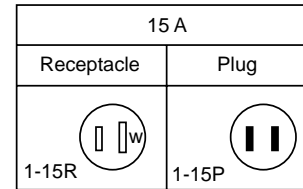
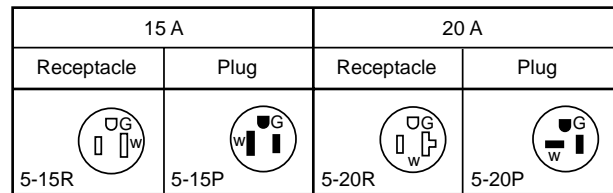

FIGURE 6.8.2(b) Grounding-type receptacle.



In bathrooms or other areas where personal safety is a concern, receptacles may have a built-in ground fault circuit interrupter. (See 6.6.2.3.)

Receptacles may have either screw terminals or push-in terminals and sometimes both. The hot conductor (usually black insulation) should be connected to the brass screw, and the neutral conductor (white insulation) to the colorless metal screw. On grounding-type receptacles, there is a screw with a green head for connecting the grounding conductor of the wiring cable.

6.8.3 Other Outlets, Devices, or Equipment. Permanent lighting fixtures are attached to electrical boxes in the wall or ceiling as appropriate with a wall switch in its individual part of the circuit. Thermostats may be mounted in walls to control permanently installed heating units.

In commercial and industrial installations, much of the electrically powered equipment is permanently connected to the basic wiring. Because of the large current draws, much of the equipment may be switched on and off by contactors rather than directly by switches.

In installations where explosive atmospheres might occur, explosionproof outlets and fixtures must be used. The outlet boxes, fittings, and attached devices are designed so that even if explosive concentrations of gases get into the system, an internal ignition will not let a flame front out to ignite the surrounding atmosphere.

6.9 Ignition by Electrical Energy.

6.9.1 General. For ignition to be from an electrical source, the following must occur:

- (1) The electrical wiring, equipment, or component must have been energized from a building's wiring, an emergency system, a battery, or some other source.
- (2) Sufficient heat and temperature to ignite a close combustible material must have been produced by electrical energy at the point of origin by the electrical source.

Ignition by electrical energy involves generating both a sufficiently high temperature and heat (i.e., competent ignition source) by passage of electrical current to ignite material that

is close. Sufficient heat and temperature may be generated by a wide variety of means, such as short-circuit and ground-fault parting arcs, excessive current through wiring or equipment, resistance heating, or by ordinary sources such as lightbulbs, heaters, and cooking equipment. The requirement for ignition is that the temperature of the electrical source be maintained long enough to bring the adjacent fuel up to its ignition temperature, with air present to allow combustion.

The presence of sufficient energy for ignition does not assure ignition. Distribution of energy and heat loss factors need to be considered. For example, an electric blanket spread out on a bed can continuously dissipate 180 W safely. If that same blanket is wadded up, the heating will be concentrated in a smaller space. Most of the heat will be held in by the outer layers of the blanket, which will lead to higher internal temperatures and possibly ignition. In contrast to the 180 W used by a typical electric blanket, just a few watts used by a small flashlight bulb will cause the filament to glow white hot, indicating temperatures in excess of 4000°F (2204°C).

In considering the possibility of electrical ignition, the temperature and duration of the heating must be great enough to ignite the initial fuels. The type and geometry of the fuel must be evaluated to be sure that the heat was sufficient to generate combustible vapors and for the heat source still to be hot enough to ignite those vapors. If the suspect electrical component is not a competent ignition source, other causes should be investigated.

6.9.2 Resistance Heating.

6.9.2.1 General. Whenever electric current flows through a conductive material, heat will be produced. See 6.2.13 for the relationships of current, voltage, resistance, and power (i.e., heating). With proper design and compliance with the codes, wiring systems and devices will have resistances low enough that current-carrying parts and connections should not overheat. Some specific parts such as lamp filaments and heating elements are designed to become very hot. However, when properly designed and manufactured and when used according to directions, those hot parts should not cause fires.

The use of copper or aluminum conductors of sufficient size in wiring systems (e.g., 12 AWG for up to 20 A for copper) will keep the resistance low. What little heat is generated should be readily dissipated to the air around the conductor under normal conditions. When conductors are thermally insulated and operating at rated currents, enough energy may be available to cause a fault or ignition.

6.9.2.2 Heat-Producing Devices. Common heat-producing devices can cause fires when misused or when certain malfunctions occur during proper use. Examples include combustibles placed too close to incandescent lamps or to heaters or coffee makers, and deep-fat fryers whose temperature controls fail or are bypassed. (See *Chapter 21*.)

6.9.2.3 Poor Connections. When a circuit has a poor connection such as a loose screw at a terminal, increased resistance causes increased heating at the contact, which promotes formation of an oxide interface. The oxide conducts current and keeps the circuit functional, but the resistance of the oxide at that point is significantly greater than in the metals. A spot of heating develops at that oxide interface that can become hot enough to glow. If combustible materials are close enough to the hot spot, they can be ignited. Generally, the connection will be in a box or appliance, and the probability of ignition is

greatly reduced. The wattage of well-developed heating connections in wiring can be up to 30–40 W with currents of 15–20 A. Heating connections of lower wattage have also been noted at currents as low as about 1 A.

6.9.3 Overcurrent and Overload. Overcurrent is the condition in which more current flows in a conductor than is allowed by accepted safety standards. The magnitude and duration of the overcurrent determines whether there is a possible ignition source. For example, an overcurrent at 25 A in a 14 AWG copper conductor should pose no fire danger except in circumstances that do not allow dissipation of the heat, such as when thermally insulated or when bundled in cable applications. A large overload of 120 A in a 14 AWG conductor, for example, would cause the conductor to glow red hot and could ignite adjacent combustibles.

Large overcurrents that persist (i.e., overload) can bring a conductor up to its melting temperature. There is a brief parting arc as the conductor melts in two. The melting opens the circuit and stops further heating.

In order to get a large overcurrent, either there must be a fault that bypasses the normal loads (i.e., short circuit) or far too many loads must be put on the circuit. To have a sustained overcurrent (i.e., overload), the protection (i.e., fuses or circuit breakers) must fail to open or must have been defeated. Ignition by overload is rare in circuits that have the proper size conductors throughout the circuit, because most of the time the protection opens and stops further heating before ignition conditions are obtained. When there is a reduction in the conductor size between the load and the circuit protection, such as an extension cord, the smaller size conductor may be heated beyond its temperature rating. This can occur without activating the overcurrent protection. For an example, see 6.2.16.

6.9.4 Arcs. An arc is a high-temperature luminous electric discharge across a gap. Temperatures within the arc are in the range of several thousand degrees, depending on circumstances including current, voltage drop, and metal involved. For an arc to jump even the smallest gap in air spontaneously, there must be a voltage difference of at least 350 V. In the 120/240 V systems being considered here, arcs do not form spontaneously under normal circumstances. (See *Section 6.12*.) In spite of the very high temperatures in an arc path, arcs may not be competent ignition sources for many fuels. In most cases, the arcing is so brief and localized that solid fuels such as wood structural members cannot be ignited. Fuels with high surface-area-to-mass ratio, such as cotton batting and tissue paper and combustible gases and vapors, may be ignited when in contact with the arc.

6.9.4.1 High-Voltage Arcs. High voltages can get into a 120/240 V system through accidental contact between the distribution system of the power company and the system on the premises. Whether there is a momentary discharge or a sustained high voltage, an arc may occur in a device for which the separation of conductive parts is safe at 240 V but not at many thousands of volts. If easily ignitable materials are present along the arc path, a fire can be started.

Lightning can send extremely high voltage surges into an electrical installation. Because the voltages and currents from lightning strikes are so high, arcs can jump at many places, cause mechanical damage, and ignite many kinds of combustibles. (See *6.12.8*.)

6.9.4.2 Static Electricity. Static electricity is a stationary charge that builds up on some objects. Walking across a carpet in a dry atmosphere will produce a static charge that can produce an arc when discharged. Other kinds of motion can cause a buildup of charge, including the pulling off of clothing, operation of conveyor belts, and the flowing of liquids. (See Section 6.12.)

6.9.4.3 Parting Arcs. A parting arc is a brief discharge that occurs as an energized electrical path is opened while current is flowing, such as by turning off a switch or pulling a plug. The arc usually is not seen in a switch but might be seen when a plug is pulled while current is flowing. Motors with brushes may produce a nearly continuous display of arcing between the brushes and the commutator. At 120/240 V ac, a parting arc is not sustained and will quickly be quenched. Ordinary parting arcs in electrical systems are usually so brief and of low enough energy that only combustible gases, vapors, and dusts can be ignited.

In arc welding, the rod must first be touched to the workpiece to start current flowing. Then the rod is withdrawn a small distance to create a parting arc. If the gap does not become too great, the arc will be sustained. A welding arc involves enough power to ignite nearly any combustible material. However, the sustained arc during welding requires specific design characteristics in the power supply that are not present in most parting arc situations in 120/240 V wiring systems.

Another kind of parting arc occurs when there is a direct short circuit or ground fault. The surge of current melts the metals at the point of contact and causes a brief parting arc as a gap develops between the metal pieces. The arc quenches immediately but can throw particles of melted metal (i.e., sparks) around. (See 6.9.5.)

6.9.4.4* Arc Tracking. Arcs may occur on surfaces of non-conductive materials if they become contaminated with salts, conductive dusts, or liquids. It is thought that small leakage currents created through such contamination cause degradation of the base material leading to the arc discharge, charring or igniting combustible materials around the arc. Arc tracking is a known phenomenon at high voltages. It has also been reported in experimental studies in 120/240 V ac systems.

Electrical current will flow through water or moisture only when that water or moisture contains contaminants such as dirt, dusts, salts, or mineral deposits. This stray current may promote electrochemical changes that can lead to electrical arcing. Most of the time the stray currents through a contaminated wet path cause enough warming that the path will dry. Then little or no current flows and the heating stops. If the moisture is continuously replenished so that the currents are sustained, deposits of metals or corrosion products can form along the electrical pathway. That effect is more pronounced in direct current situations. A more energetic arc through the deposits might cause a fire under the right conditions. More study is needed to more clearly define the conditions needed for causing a fire.

6.9.5 Sparks. Sparks are luminous particles that can be formed when an arc melts metal and spatters the particles away from the point of arcing. The term *spark* has commonly been used for a high voltage discharge as with a spark plug in an engine. For purposes of electrical fire investigation, the term *spark* is reserved for particles thrown out by arcs, whereas an arc is a luminous electrical discharge across a gap.

Short circuits and high-current ground faults, such as when the ungrounded conductor (i.e., hot conductor) touches the

neutral or a ground, produce violent events. Because there may be very little resistance in the short circuit, the fault current may be many hundreds or even thousands of amperes. The energy that is dissipated at the point of contact is sufficient to melt the metals involved, thereby creating a gap and a visible arc and throwing sparks. Protective devices in most cases will open (i.e., turn off the circuit) in a fraction of a second and prevent repetition of the event.

When just copper and steel are involved in arcing, the spatters of melted metal begin to cool immediately as they fly through the air. When aluminum is involved in faulting, the particles may actually burn as they fly and continue to be extremely hot until they burn out or are quenched by landing on some material. Burning aluminum sparks, therefore, may have a greater ability to ignite fine fuels than do sparks of copper or steel. However, sparks from arcs in branch circuits are inefficient ignition sources and can ignite only fine fuels when conditions are favorable. In addition to the temperature, the size of the particles is important for the total heat content of the particles and the ability to ignite fuels. For example, sparks spattered from a welding arc can ignite many kinds of fuels because of the relatively large size of the particles and the total heat content. Arcing in entry cables can produce more and larger sparks than can arcing in branch circuits.

6.9.6 High-Resistance Faults. High-resistance faults are long-lived events in which the fault current is not high enough to trip the circuit overcurrent protection, at least in the initial stages. A high-resistance fault on a branch circuit may be capable of producing energy sufficient to ignite combustibles in contact with the point of heating. It is rare to find evidence of a high-resistance fault after a fire. An example of a high-resistance fault is an energized conductor coming into contact with a poorly grounded object.

6.10 Interpreting Damage to Electrical Systems.

6.10.1 General. Abnormal electrical activity will usually produce characteristic damage that may be recognized after a fire. Evidence of this electrical activity may be useful in locating the area of origin. The damage may occur on conductors, contacts, terminals, conduits, or other components. However, many kinds of damage can occur from nonelectrical events. This section will give guidelines for deciding whether observed damage was caused by electrical energy and whether it was the cause of the fire or a result of the fire. These guidelines are not absolute, and many times the physical evidence will be ambiguous and will not allow a definite conclusion. Figure 6.10.1 illustrates some of the types of damage that may be encountered.

6.10.2* Short-Circuit and Ground-Fault Parting Arcs. Whenever an energized conductor contacts a grounded conductor or a metal object that is grounded with nearly zero resistance in the circuit, there will be a surge of current in the circuit and melting at the point of contact. This event may be caused by heat-softened insulation due to a fire. The high current flow produces heat that can melt the metals at the points of contact of the objects involved, thereby producing a gap and the parting arc. A solid copper conductor typically appears as though it had been notched with a round file, as shown in Figure 6.10.2(a). The notch may or may not sever the conductor. The conductor will break easily at the notch upon handling. The surface of the notch can be seen by microscopic examination to have been melted. Sometimes, there can be a projection of porous copper in the notch.

FIGURE 6.10.1 Guide for interpreting damage to electrical wires.



Mode of damage	Effects	Result of	Cause of fire?
Arcing through char		Direct fire heating	No, always a result of fire
Parting arcing		Heating at about 400°F (205°C) but no direct fire	Usually not
Overcurrent		Short circuit or failure in a device plus failure of overcurrent protection	Yes, but also may be a result of fire
Fire		Cable exposed to existing fire	N/A
Heating connection		Connection not tight	Yes
Mechanical		Scraping or gouging by something	No
Alloying		Melted aluminum on the wire	No

FIGURE 6.10.2(a) A solid copper conductor notched by a short circuit.

The parting arc melts the metal only at the point of initial contact. The adjacent surfaces will be unmelted unless fire or some other event causes subsequent melting. In the event of subsequent melting, it may be difficult to identify the site of the initial short circuit or ground fault. If the conductors were insulated prior to the faulting and the fault is suspected as the cause of the fire, it will be necessary to determine how the insulation failed or was removed and how the conductors came in contact with each other. If the conductor or other metal object involved in the short circuit or ground fault was bare of insulation at the time of the faulting, there may be spatter of metal onto the otherwise unmelted adjacent surfaces.

Stranded conductors, such as for lamp and appliance cords, appear to display effects from short circuits and ground faults that are less consistent than those in solid conductors. A stranded conductor may exhibit a notch with only some of the strands severed, or all of the strands may be severed with strands fused together or individual strands melted. [See Figure 6.10.2(b).]

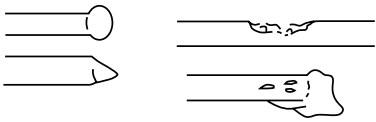
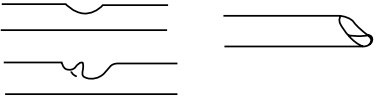
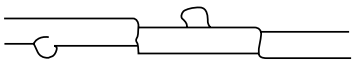
FIGURE 6.10.2(b) Stranded copper lamp cord that was severed by a short circuit.

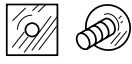
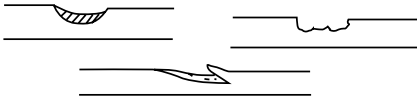
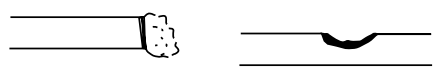
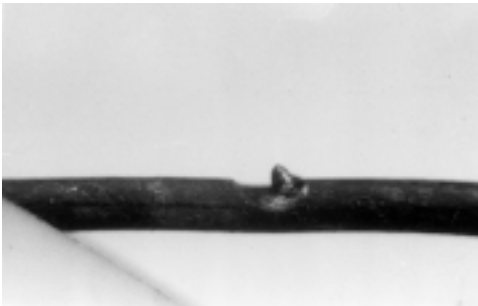
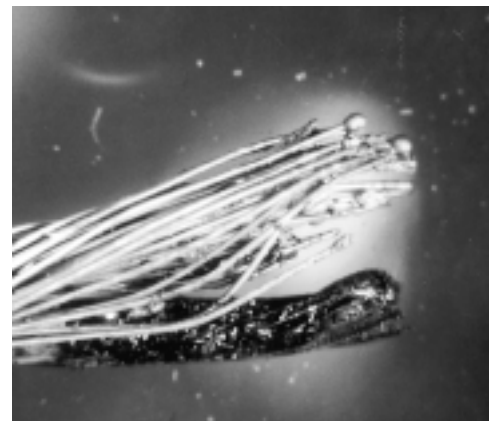
6.10.3* Arcing Through Char. Insulation on conductors, when exposed to direct flame or radiant heat, may be charred before being melted. That char, when exposed to fire, is conductive enough to allow sporadic arcing through the char. That arcing can leave surface melting at spots or can melt through the conductor, depending on the duration and repetition of the arcing. There often will be multiple points of arcing. Several inches of conductor can be destroyed either by melting or severing of several small segments.

When conductors are subject to highly localized heating, such as from arcing through char, the ends of individual conductors may be severed. When severed, they will have beads on the end, as shown in Figure 6.10.3(a). The bead may weld two conductors together, as shown in Figure 6.10.3(b). If the conductors are in conduit, holes may be melted in the conduit. Beads can be differentiated from globules, which are created by nonlocalized heating such as overload or fire melting. Beads are characterized by the distinct and identifiable line of demarcation between the melted bead and the adjacent unmelted portion of the conductor. Figures 6.10.3(c), 6.10.3(d), 6.10.3(e), and 6.10.3(f) show examples.

FIGURE 6.10.3(a) Copper conductors severed by arcing through the charred insulation.

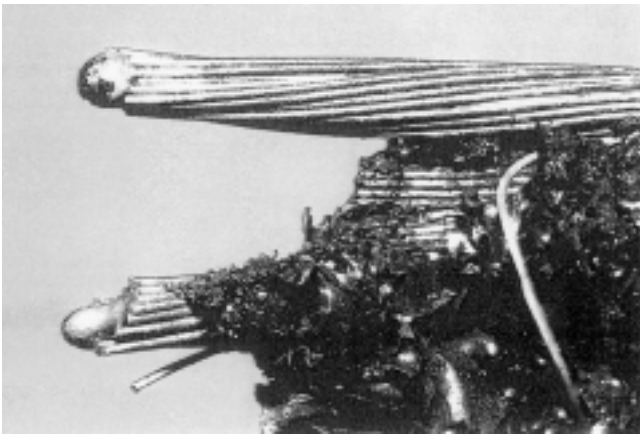

FIGURE 6.10.3(b) Copper conductors severed by arcing through the charred insulation with a large bead welding the two conductors together.



FIGURE 6.10.3(c) Stranded copper conductors severed by arcing through charred insulation with the strands terminated in beads.

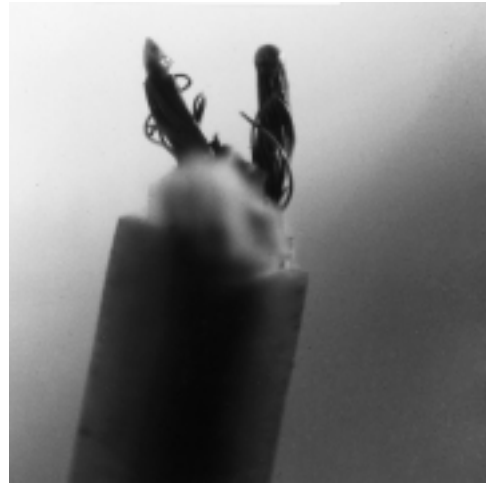

FIGURE 6.10.3(d) Arc damage to 18 AWG cord by arcing through charred insulation.

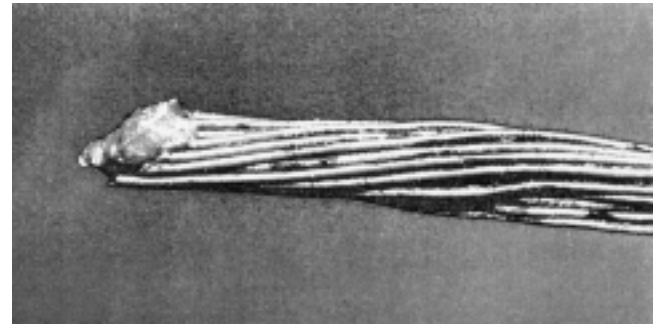

FIGURE 6.10.3(e) Spot arc damage to 14 AWG conductor caused by arcing through charred insulator (lab test).

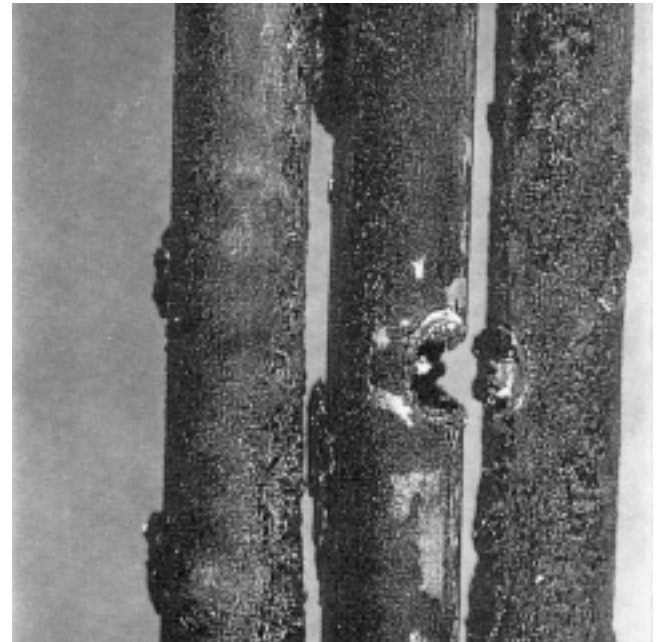
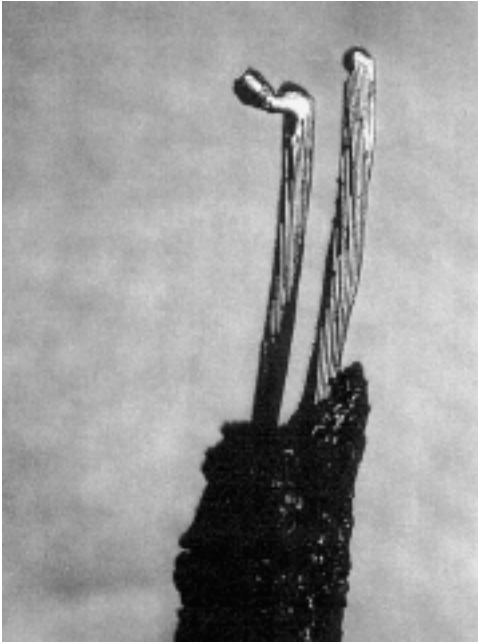

FIGURE 6.10.3(f) Arc damage to 18 AWG cord by arcing through charred insulation (lab test).



The conductors downstream from the power source and the point where the conductors are severed become de-energized. Those conductors will likely remain in the debris with part or all of their insulation destroyed. The upstream remains of the conductors between the point of arc-severing and the power supply may remain energized if the overcurrent protection does not function. Those conductors can sustain further arcing through the char. In a situation with multiple arc-severing on the same circuit, arc-severing farthest from the power supply occurred first. It is necessary to find as much of the conductors as possible to determine the location of the first arcing through char. This will indicate the first point on the circuit to be compromised by the fire and may be useful in determining the area of origin. In branch circuits, holes extending for several inches may be seen in the conduit or in metal panels to which the conductor arced.

If the fault occurs in service entrance conductors, several feet of conductor may be partly melted or destroyed by repeated arcing because there is usually no overcurrent protection for the service entrance. An elongated hole or series of holes extending several feet may be seen in the conduit.

6.10.4* Overheating Connections. Connection points are the most likely place for overheating to occur on a circuit. The most likely cause of the overheating will be a loose connection or the presence of resistive oxides at the point of connection. Metals at an overheating connection will be more severely oxidized than similar metals with equivalent exposure to the fire. For example, an overheated connection on a duplex receptacle will be more severely damaged than the other connections on that receptacle. The conductor and terminal parts may have pitted surfaces or may have sustained a loss of mass where poor contact has been made. This loss of mass can appear as missing metal or tapering of the conductor. These effects are more likely to survive the fire when copper conductors are connected to steel terminals. Where brass or aluminum are involved at the connection, the metals are more likely to be melted than pitted. This melting can occur either from resis-

tance heating or from the fire. Pitting also can be caused by alloying. (See 6.10.6.3.)

6.10.5* Overload. Currents in excess of rated ampacity produce effects in proportion to the degree and duration of overcurrent. Overcurrents that are large enough and persist long enough to cause damage or create a danger of fire are called overloads. Under any circumstance, suspected overloads require that the circuit protection be examined. The most likely place for an overload to occur is on an extension cord. Overloads are unlikely to occur on wiring circuits with proper overcurrent protection.

Overloads cause internal heating of the conductor. This heating occurs along the entire length of the overloaded portion of the circuit and may cause sleeving. Sleeving is the softening and sagging of thermoplastic conductor insulation due to heating of the conductor. If the overload is severe, the conductor may become hot enough to ignite fuels in contact with it as the insulation melts off. Severe overloads may melt the conductor. If the conductor melts in two, the circuit is opened and heating immediately stops. The other places where melting had started may become frozen as offsets. This effect has been noted in copper, aluminum, and Nichrome® conductors. (See Figure 6.10.5.) The finding of distinct offsets is an indication of a large overload. Evidence of overcurrent melting of conductors is not proof of ignition by that means.

FIGURE 6.10.5 Aluminum conductor severed by overcurrent showing offsets.

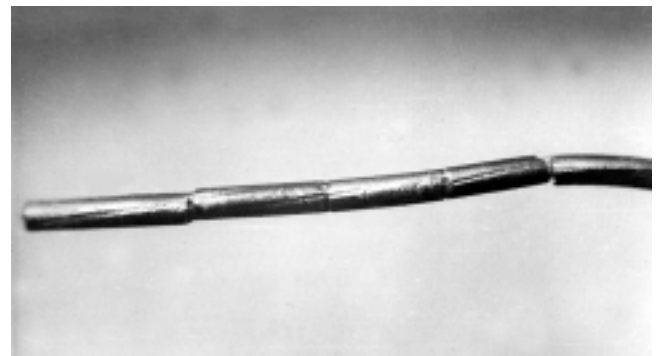

Overload in service entrance cables is more common than in branch circuits but is usually a result of fire. Faulting in entrance cables produces sparking and melting only at the point of faulting unless the conductors maintain continuous contact to allow the sustained massive overloads needed to melt long sections of the cables.

6.10.6 Effects Not Caused by Electricity. Conductors may be damaged before or during a fire by other than electrical means and often these effects are distinguishable from electrical activity.

6.10.6.1 Conductor Surface Colors. When the insulation is damaged and removed from copper conductors by any means, heat will cause dark red to black oxidation on the conductor surface. Green or blue colors may form when some acids are present. The most common acid comes from the decomposition of PVC. These various colors are of no value in determining cause because they are nearly always results of the fire condition.

6.10.6.2 Melting by Fire. When exposed to fire or glowing embers, copper conductors may melt. At first, there is blistering and distortion of the surface, as shown in Figure 6.10.6.2(a). The striations created on the surface of the conductor during manufacture become obliterated. The next stage is some flow of copper on the surface with some hanging drops forming. Further melting may allow flow with thin areas (i.e., necking and drops), as shown in Figure 6.10.6.2(b). In that circumstance, the surface of the conductor tends to become smooth. The resolidified copper forms globules. Globules caused by exposure to fire are irregular in shape and size. They are often tapered and may be pointed. There is no distinct line of demarcation between melted and unmelted surfaces.

FIGURE 6.10.6.2(a) Copper conductors fire-heated to the melting temperature, showing regions of flow of copper, blistering, and no surface distortion.



FIGURE 6.10.6.2(b) Fire-heated copper conductors, showing globules.

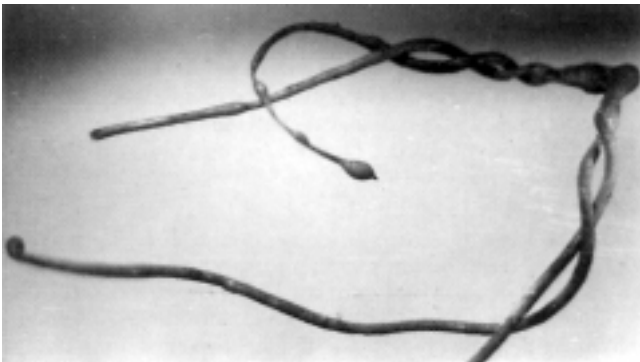

Stranded conductors that just reach melting temperatures become stiffened. Further heating can let copper flow among the strands so that the conductor becomes solid with an irregular surface that can show where the individual strands were, as shown in Figure 6.10.6.2(c). Continued heating can cause the flowing, thinning, and globule formation typical of solid conductors. Magnification is needed to see some of these effects. Large-gauge stranded conductors that melt in fires can have the strands fused together by flowing metal or the strands may be thinned and stay separated. In some cases, individual strands may display a bead-like globule even though the damage to the conductor was from melting. Figures 6.10.6.2(d) and 6.10.6.2(e) show some examples.

Aluminum conductors melt and resolidify into irregular shapes that are usually of no value for interpreting cause, as shown in Figure 6.10.6.2(f). Because of the relatively low melting temperature, aluminum conductors can be expected to melt in almost any fire and rarely aid in finding the cause.

FIGURE 6.10.6.2(c) Stranded copper conductor in which melting by fire caused the strands to be fused together.

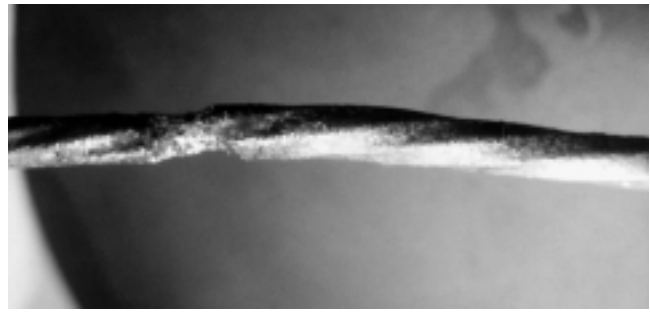

FIGURE 6.10.6.2(d) Fire melting of stranded copper wire.

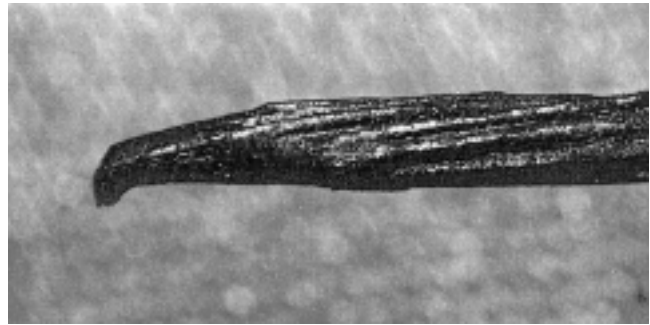

FIGURE 6.10.6.2(e) Another example of fire melting of stranded copper wire.



6.10.6.3* Alloying. Metals such as aluminum and zinc can form alloys when melted in the presence of other metals. If aluminum drips onto a bare copper conductor during a fire and cools, the aluminum will be just lightly stuck to the copper. If that spot is further heated by fire, the aluminum can penetrate the oxide interface and form an alloy with the copper that melts at a lower temperature than does either pure metal. After the fire, an aluminum alloy spot may appear as a rough gray area on the surface, or it may be a shiny silvery area. The copper-aluminum alloy is brittle, and the conductor may readily break if it is bent at the spot of alloying. If the melted alloy drips off the conductor during the fire, there will be a pit that is lined with alloy. The presence of alloys can be confirmed by chemical analysis.

Aluminum conductors that melt from fire heating at a terminal may cause alloying and pitting of the terminal pieces. There is no clear way of visually distinguishing alloying from the effects of an overheating connection. Zinc forms a brass alloy readily with copper. It is yellowish in color and not as brittle as the aluminum alloy.

FIGURE 6.10.6.2(f) Aluminum cables that were melted by fire showing thinned areas, bulbous areas, and pointed ends.

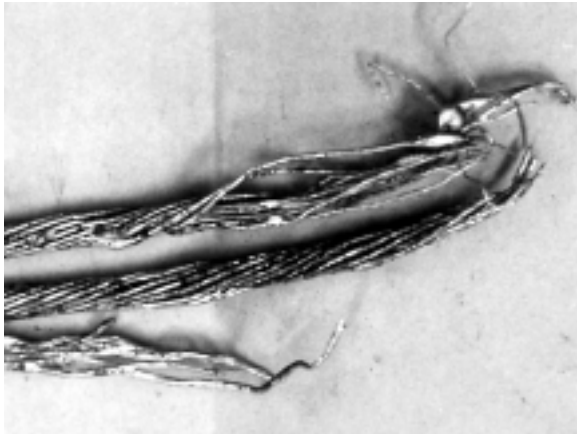

Copper and silver may also form alloys. This can occur at temperatures below their melting point. The alloys may be seen on contacts, electrical switches, thermostats, thermal protectors, contactors, relays, and similar items.

Copper conductors, terminated in connections, or terminals containing solder may have areas of alloying, globules, rounded ends, or pitting after a fire. These effects are caused by the interaction between the copper and the solder.

6.10.6.4* Mechanical Gouges. Gouges and dents that are formed in a conductor by mechanical means can usually be distinguished from arcing marks by microscopic examination. Mechanical gouges will usually show scratch marks from whatever caused the gouge. Dents will show deformation of the conductors beneath the dents. Dents or gouges will not show the fused surfaces caused by electrical energy.

6.11 Identification of Arc Melting of Electrical Conductors. Melted electrical conductors can be examined to determine if the damage is evidence of electrical arcing or melting by fire.

6.11.1 Melting Caused by Electrical Arcing. Electrical arcing produces very high temperatures and localized heating in the path of the arc, which typically melts electrical conductors at the locations where the arc makes contact with them. Because the arc itself is normally small in area and short in duration, the arc damage is localized, with a sharp line of demarcation between the melted and unmelted portions of the conductor. Magnification may be necessary to detect the demarcation between the melted and unmelted regions on a conductor.

The result of arc damage can be notches in the sides of the conductors [see Figure 6.10.2(a) and Figure 6.10.3(e)], or rounded or irregular-shaped beading on the end of a severed conductor [see Figures 6.10.3(a), 6.10.3(b), 6.10.3(c), 6.10.3(d), and 6.10.3(f)]. Arcing often produces sparks that are sprayed from the arc location and that may collect on nearby areas of the conductor.

6.11.2 Melting Caused by Fire. In contrast to melting caused by an arc, when conductors are melted by fire, the damage is spread over a larger area without a distinct line of demarcation between the melted and unmelted regions (see 6.10.6.2). Conductors melted by fire may exhibit irregular or rounded globules, or smooth or rough tapered ends.

6.11.3 Considerations and Cautions. Laboratory experiments, combined with the knowledge of basic chemical, physical, and

electrical sciences, indicate that some prior beliefs are incorrect or are correct only under limited circumstances.

6.11.4 Undersized Conductors. Undersized conductors, such as a 14 AWG conductor in a 20 A circuit, are sometimes thought to overheat and cause fires. There is a large safety factor in the allowed ampacities. Although the current in a 14 AWG conductor is supposed to be limited to 15 A, the extra heating from increasing the current to 20 A would not necessarily indicate a fire cause. The higher operating temperature would deteriorate the insulation faster but would not melt it or cause it to fall off and bare the conductor without some additional factors to generate or retain heat. The presence of undersized conductors or overfused protection is not proof of a fire cause. (See 6.2.16.)

6.11.5 Nicked or Stretched Conductors. Conductors that are reduced in cross section by being nicked or gouged are sometimes thought to heat excessively at the nick. Calculations and experiments have shown that the additional heating is negligible. Also, it is sometimes thought that pulling conductors through conduit can stretch them like taffy and reduce the cross section to a size too small for the ampacity of the protection. Copper conductors do not stretch that much without breaking at the weakest point. Whatever stretching can occur before the range of plastic deformation is exceeded would not cause either a significant reduction in cross section or excessive resistance heating.

6.11.6 Collecting Evidence. Damage to electrical conductors should be treated as potential evidence. The damaged portion of the relevant conductors should be documented at the fire scene before being disturbed. The documentation should include the location of the damage and whether the wiring was from a branch circuit or from an electrical device.

If the damaged conductor is to be cut from its circuit, the cut should not be made in the damaged portion. Instead, it should be cut far enough away from the damaged area to include a section of unmelted or undamaged conductor. The conductors should not be cleaned, because the surface material is evidence that may be needed for future analysis and evaluation. The evidence should be preserved and packaged so as to protect it from mechanical abrasion, accidental fracture of the wires, or other damage. Different pieces of evidence should be packaged separately.

6.11.7 Deteriorated Insulation. When thermoplastic insulation deteriorates with age and heating, it tends to become brittle and will crack if bent. Those cracks do not allow leakage current unless conductive solutions get into the cracks. Rubber insulation does deteriorate more easily than thermoplastic insulation and loses more mechanical strength. Thus, rubber-insulated lamp or appliance cords that are subject to being moved can become hazardous because of embrittled insulation breaking off. However, simple cracking of rubber insulation, as with thermoplastic insulation, does not allow leakage of current unless conductive solutions get into the cracks.

6.11.8* Overdriven or Misdriven Staple. Staples driven too hard over nonmetallic cable have been thought to cause heating or some kind of faulting. The suppositions range from induced currents because of the staple being too close to the conductors to actually cutting through the insulation and touching the conductors. A properly installed cable staple with a flattened top cannot be driven through the insulation. If the staple is bent over, the edge of it can be driven through the insulation to contact the conductors. In that case, a short

circuit or a ground fault would occur. That event should be evident after a fire by bent points of the staple and by melt spots on the staple or on the conductors unless obliterated by the ensuing fire. A short circuit should cause the circuit overcurrent protection to operate and prevent any further damage. There would not be any continued heating at the contact, and the brief parting arc would not ignite the insulation on the conductor or the wood to which it was stapled.

If a staple is misdriven so that one leg of the staple penetrates the insulation and contacts both an energized conductor and a grounded conductor, then a short circuit or ground fault will result. If the staple severs the energized conductor, a heating connection may be formed at that point.

6.11.9 Short Circuit. A short circuit (i.e., low resistance and high current) in wiring on a branch circuit has been thought to ignite insulation on the conductors and to allow fire to propagate. Normally, the quick flash of a parting arc prior to operation of the circuit protection cannot heat insulation enough to generate ignitable fumes, even though the temperature of the core of the arc may be several thousand degrees. If the overcurrent protection is defeated or defective, then a short circuit may become an overload and, as such, may become an ignition source.

6.11.10 Beaded Conductor. A bead on the end of a conductor in and of itself does not indicate the cause of the fire.

6.12 Static Electricity.

6.12.1 Introduction to Static Electricity. Static electricity is the electrical charging of materials through physical contact and separation and the various effects that result from the positive and negative electrical charges formed by this process. Static electricity is accomplished by the transfer of electrons (negatively charged) between bodies, one giving up electrons and becoming positively charged, and the other gaining electrons and becoming oppositely, but equally, negatively charged.

Common sources of static electricity include the following:

- (1) Pulverized materials passing through chutes or pneumatic conveyors
- (2) Steam, air, or gas flowing from any opening in a pipe or hose, when the steam is wet or when the air or gas stream contains particulate matter
- (3) Nonconductive power or conveyor belts in motion
- (4) Moving vehicles
- (5) Nonconductive liquids flowing through pipes or splashing, pouring, or falling
- (6) Movement of clothing layers against each other or contact of footwear with floors and floor coverings while walking
- (7) Thunderstorms that produce violent air currents and temperature differences that move water, dust, and ice crystals, creating lightning
- (8) Motions of all sorts that involve changes in relative position of contacting surfaces, usually of dissimilar liquids or solids

6.12.2 Generation of Static Electricity. The generation of static electricity cannot be prevented absolutely, but this is of little consequence because the development of electrical charges may not in itself be a potential fire or explosion hazard. For there to be an ignition, there must be a discharge or sudden recombination of the separated positive and negative charges in the form of an electric arc in an ignitable atmosphere.

When an electrical charge is present on the surface of a nonconducting body, where it is trapped or prevented from escaping, it is called static electricity. An electric charge on a conducting body that is in contact only with nonconductors is also prevented from escaping and is therefore nonmobile or *static*. In either case, the body is said to be *charged*. The charge may be either positive (+) or negative (-).

6.12.2.1* Ignitable Liquids. Static is generated when liquids move in contact with other materials. This commonly occurs in operations such as flowing through pipes, and in mixing, pouring, pumping, spraying, filtering, or agitating. Under certain conditions, particularly with liquid hydrocarbons, static may accumulate in the liquid. If the accumulation of charge is sufficient, a static arc may occur. If the arc occurs in the presence of a flammable vapor-air mixture, an ignition may result.

Filtering with some types of clay or microfilters substantially increases the ability to generate static charges. Tests and experience indicate that some filters of this type have the ability to generate charges 100 to 200 times higher than achieved without such filters.

The electrical conductivity of a liquid is a measure of its ability to create, accumulate, and hold a charge. The lower the conductivity, the greater the ability of the liquid to create and hold a charge. Common liquids that have low conductivity and therefore represent a hazardous static potential are given in Table 6.12.2.1. For comparison, distilled water has a conductivity of 100,000,000 pico-siemen.

Table 6.12.2.1 Common Liquids that Have Low Conductivity

Typical Conductivity Product	Conductance per Meter in Pico-Siemen*
Highly purified hydrocarbons ^a	0.01
Light distillates ^a	0.01 to 10
Commercial jet fuel ^b	0.2 to 50
Kerosene ^b	1 to 50
Leaded gasoline ^b	above 50
Fuel with antistatic additives ^b	50 to 300
Black oils ^a	1000 to 100,000

*Pico-siemen is the reciprocal of ohms. One pico-siemen is 1 trillionth (1×10^{-12}) of a siemen.

^aAPI RP 2003, *Protection Against Ignitions Arising Out of Static, Lightning, and Stray Currents*.

^bBustin and Duket, *Electrostatic Hazards in Petroleum Industry*.

6.12.2.2 Charges on the Surface of a Liquid. If an electrically charged liquid is poured, pumped, or otherwise transferred into a tank or container, the unit charges of similar polarity within the liquid will be repelled from each other toward the outer surfaces of the liquid, including not only the surfaces in contact with the container walls but also the top surface adjacent to the air or vapor space, if any. It is the latter charge, often called the *surface charge*, that is of most concern in many situations. In most cases, the container is of metal, and hence electrically conductive.

Even if the tank shell is grounded, the time for the charge to dissipate, known as relaxation time, may be as little as a few seconds up to several minutes. This relaxation time is dependent on the conductivity of the liquid and the rate and manner

that the liquid is being introduced into the tank, therefore, the rate at which the electrostatic charge is being accumulated.

If the electrical potential difference between any part of the liquid surface and the metal tank shell should become high enough, the air above the liquid may become ionized and an arc may discharge to the shell. However, an arc to the tank shell is less likely than an arc to some projection or to a conductive object lowered into the tank. These projections or objects are known as spark (i.e., arc) promoters. No bonding or grounding of the tank or container can remove this internal charge.

If the tank or container is ungrounded, the charge can also be transmitted to the exterior of the tank and can arc to any grounded object brought into proximity to the now charged tank external surface.

6.12.2.3* Switch Loading. *Switch loading* is a term used to describe a product being loaded into a tank or compartment that previously held a product of different vapor pressure and flash point. Switch loading can result in an ignition when a low vapor pressure/higher flash point product, such as fuel oil, is put into a cargo tank containing a flammable vapor from a previous cargo, such as gasoline. Discharge of the static normally developed during the filling can ignite the vapor-air mixture remaining from the low flash point liquid.

6.12.2.4 Spraying Operations. High-pressure spraying of ignitable liquids, such as in spray painting, can produce significant static electric charges on the surfaces being sprayed and the ungrounded spraying nozzle or gun.

If the material being sprayed can create an ignitable atmosphere, such as with paints utilizing flammable solvents, a static discharge can ignite the fuel-air mixture.

In general, high-pressure airless spraying apparatus have a higher possibility for creating dangerous accumulations of static than low-pressure compressed air sprayers.

6.12.2.5 Gases. When flowing gas is contaminated with metallic oxides or scale particles, with dust, or with liquid droplets or spray, static electric accumulations may result. A stream of particle-containing gas directed against a conductive object will charge the object unless the object is grounded or bonded to the liquid discharge pipe. If the accumulation of charge is sufficient, a static arc may occur. If the arc occurs in the presence of an ignitable atmosphere, an ignition may result.

6.12.2.6 Dusts and Fibers. Generation of a static charge can happen during handling and processing of dusts and fibers in industry. Dust dislodged from a surface or created by the pouring or agitation of dust-producing material, such as grain or pulverized material, can result in the accumulation of a static charge on any insulated conductive body with which it comes in contact.

The minimum electrical energy required to ignite a dust cloud is typically in the range of 10 to 100 millijoules. Thus, many dusts can ignite with less energy than might be expended by a static arc from machinery or the human body.

6.12.2.7 Human Body. The human body can accumulate an electric charge that in dry atmospheres (e.g., less than 50 percent relative humidity) can be as high as several thousand volts.

6.12.2.8 Clothing. Outer garments can build up considerable static charges when layers of clothing are separated, moved away from the body, or removed entirely, particularly when of

dissimilar fabrics. For some materials (particularly synthetic polymers) and/or low humidity conditions, an electrostatic charge may be accumulated. The use of synthetic fabrics and the removal of outer garments in ignitable atmospheres can become an ignition source.

6.12.3* Incendive Arc. An arc that has enough energy to ignite an ignitable mixture is said to be incendive. A nonincendive arc does not possess the energy required to cause ignition even if the arc occurs within an ignitable mixture. An ignitable mixture is commonly a gas, vapor of an ignitable liquid, or dust.

When the stored energy is high enough, and the gap between two bodies is small enough, the stored energy is released, producing an arc. The energy so stored and released by the arc is related to the capacitance of the charged body and the voltage in accordance with the following formula:

$$E_s = \frac{CV^2}{2}$$

where:

E_s = energy in joules

C = capacitance in farads

V = voltage in volts

Static arc energy is typically reported in thousandths of a joule (millijoules or mJ).

6.12.4* Ignition Energy. The ability of an arc to produce ignition is governed largely by its energy and the minimum ignition energy of the exposed fuel. The energy of the static arc will necessarily be some fraction of its total stored energy. Some of the total stored energy will be expended in heating the electrodes. With flat plane electrodes, the minimum arc voltage to jump a gap (0.01 mm) is 350 V. Increased gap widths require proportionately larger voltages; for example, 1 mm requires approximately 4500 V.

Though as little as 350 V is required to arc across a small gap, it has been shown by practical and experimental experience that, because of heat loss to the electrodes, arcs arising from electrical potential differences of at least 1500 V are required to be incendive.

Dusts and fibers require a discharge energy of 10 to 100 times greater than gases and vapors for arc ignitions of optimum mixtures with air. See Table 3.3.4 and Table 18.13.2 for additional minimum ignition energies.

6.12.5 Controlling Accumulations of Static Electricity. A static charge can be removed or can dissipate naturally. A static charge cannot persist except on a body that is electrically insulated from its surroundings.

6.12.5.1 Humidification. Many commonly encountered materials that are not usually considered to be electrical conductors — such as paper, fabrics, carpet, clothing, and cellulose and other dusts — contain certain amounts of moisture in equilibrium with the surrounding atmosphere. The electrical conductivity of these materials is increased in proportion to the moisture content of the material, which depends on the relative humidity of the surrounding atmosphere.

Under conditions of high relative humidity, 50 percent or higher, these materials and the atmosphere will reach equilibrium and contain enough moisture to make the conductivity adequate to prevent significant static electricity accumulations. With low relative humidities of approximately 30 percent or less, these materials dry out and become good insulators, so static accumulations are more likely.

Materials such as plastic or rubber dusts or machine drive belts, which do not appreciably absorb water vapor, can remain insulating surfaces and accumulate static charges even though the relative humidity approaches 100 percent.

The conductivity of the air itself is not appreciably increased by humidity.

6.12.5.2 Bonding and Grounding. Bonding is the process of electrically connecting two or more conductive objects. Grounding is the process of electrically connecting one or more conductive objects to ground potential and is a specific form of bonding.

A conductive object may also be grounded by being bonded to another conductive object that is already at ground potential. Some objects, such as underground metal pipe or large metal tanks resting on the earth, may be inherently grounded by their contact with the earth.

Bonding minimizes electrical potential differences between objects. Grounding minimizes potential differences between objects and the earth. Examples of these techniques include metal-to-metal contact between fixed objects and pickup brushes between moving objects and earth.

Investigators should not take the conditions of bonding or grounding for granted just by the appearance or contact of the objects in question. Specific electrical testing should be done to confirm the bonding or grounding conditions.

If static arcing is suspected as an ignition source, examination and testing of the bonding, grounding, or other conductive paths should be made by qualified personnel using the criteria in NFPA 77, *Recommended Practice on Static Electricity*.

6.12.6 Conditions Necessary for Static Arc Ignition. In order for a static discharge to be a source of ignition, five conditions must be fulfilled:

- (1) There must be an effective means of static charge generation.
- (2) There must be a means of accumulating and maintaining a charge of sufficient electrical potential.
- (3) There must be a static electric discharge arc of sufficient energy. (*See Section 16.3.*)
- (4) There must be a fuel source in the appropriate mixture with a minimum ignition energy less than the energy of the static electric arc. (*See Section 16.4.*)
- (5) The static arc and fuel source must occur together in the same place and at the same time.

6.12.7 Investigating Static Electric Ignitions. Often the investigation of possible static electric ignitions depends on the discovery and analysis of circumstantial evidence and the elimination of other ignition sources, rather than on direct physical evidence.

In investigating static electricity as a possible ignition source, the investigator should identify whether or not the five conditions necessary for ignition existed.

An analysis must be made of the mechanism by which static electricity was generated. This analysis should include the identification of the materials or implements that caused the static accumulation, the extent of their electrical conductivity, and their relative motion, contact and separation, or means by which electrons are exchanged.

The means of accumulating charge to sufficient levels where it can discharge in the form of an incendive arc should be identified. The states of bonding, grounding, and conductance of the material that accumulates the charge or to which the arc discharges should be identified.

Local records of meteorological conditions, including relative humidity, should be obtained and the possible influence on static accumulation or dissipation (relaxation) considered.

The location of the static electric arc should be determined as exactly as possible. In doing so, there is seldom any direct physical evidence of the actual discharge arc, if it occurred. Occasionally, there are witness accounts that describe the arc taking place at the time of the ignition. However, the investigator should endeavor to verify witness accounts through analysis of physical and circumstantial evidence.

The investigator should determine whether the arc discharge could have been of sufficient energy to be a competent ignition source for the initial fuel.

The potential voltage and energy of the arc in relation to the size of the arc gap should be calculated to determine whether the incendive arc is feasible.

The possibility for the incendive arc and the initial fuel (in the proper configuration and mixture) to exist in the same place at the same time should be established.

6.12.8* Lightning. Lightning is another form of static electricity in which the charge builds up on and in clouds and on the earth below. Movement of water droplets, dust, and ice particles in the violent winds and updrafts of a thunderstorm build up a polarized electrostatic charge in the clouds. When sufficient charge builds up, a discharge occurs in the form of a lightning stroke between the charged cloud and objects of different potential.

Lightning strokes may occur between clouds or between clouds and the earth. In the latter, charges of opposite polarity are generated in the cloud, while the charge in the ground below the cloud is induced by the cloud charge. In effect, the result is a giant capacitor, and when the charge builds up sufficiently, a discharge occurs.

6.12.8.1 Lightning Bolt Characteristics. Typically lightning bolts have a core of energy plasma $1/2$ to $3/4$ in. (1.27 to 1.9 cm) in diameter, surrounded by a 4 in. (10.2 cm) thick channel of superheated ionized air. Lightning bolts average 24,000 A but can exceed 200,000 A, and potentials can range up to 15,000,000 V.

6.12.8.2 Lightning Strikes. Lightning tends to strike the tallest object on the ground in the path of its discharge. Lightning enters structures in four ways:

- (1) By striking a metallic object like a TV antenna, a cupola, or an air-conditioning unit extending up and out from the building roof
- (2) By directly striking the structure
- (3) By hitting a nearby tree or other tall structure and moving horizontally to the building
- (4) By striking nearby overhead conductors and by being conducted into buildings along the normal power lines

The bolt generally follows a conductive path to ground. At points along its path, the main bolt may divert, for example, from wiring to plumbing, particularly if underground water piping is used as a grounding device for the structure's electrical system.

6.12.8.3 Lightning Damage. Damage by lightning is caused by two characteristic properties: first, the extremely high electrical potentials and energy in a lightning stroke; and second, the extremely high heat energy and temperatures generated by the electrical discharge. Examples of these effects are as follows.

(a) A tree may be shattered by the explosive action of the lightning stroke striking the tree and the heat immediately vaporizing the moisture in the tree into steam, causing explosive effects.

(b) Copper conductors not designed to carry the thousands of amperes of a lightning stroke may be melted, severed, or completely vaporized by the overcurrent effect of a lightning discharge. It is also characteristic for electrical conductors that have experienced significant overcurrents to become severed and disjointed at numerous locations along their length, due to the extremely powerful magnetic fields generated by such overcurrents.

(c) When lightning strikes a steel-reinforced concrete building, the electricity may follow the steel reinforcing rods as the least resistive conductive path. The high energy and high temperature may destroy the surrounding concrete with explosive forces.

6.12.8.4 Lightning Detection Networks. Lightning detection networks exist that may assist in establishing time and location (to within 500 meters) of a lightning strike. Historical data is also available, including report of any lightning strikes detected within a specified time prior to a fire.

Chapter 7 Building Fuel Gas Systems

7.1 Introduction. Fuel gas systems are found in or near most dwelling, storage, commercial, or industrial use structures. They commonly provide fuel for environmental comfort, water heating, cooking, and manufacturing processes. They can be fuel sources for fires in these structures. The fire investigator or analyst should have a basic understanding of fuel gases and the appliances and equipment that utilize them. NFPA 54, *National Fuel Gas Code*, and NFPA 58, *Liquefied Petroleum Gas Code*, are generally considered to be the leading standards on this topic.

7.1.1 Impact of Fuel Gases on Fire and Explosion Investigations. Building fuel gas systems can influence the way a building burns in four ways: as an initial fuel source, as an initial ignition source, as both fuel and ignition sources, and as factors influencing fire spread. These influences can complicate the investigative process. The investigator should know at least the rudiments of fuel gas systems, how they work, and how they fail.

7.1.1.1 Fuel Sources. Fuel gases that escape from their piping, storage, or utilization systems can serve as easily ignited fuels for fires and explosions. These gases are commonly referred to as *fugitive* gases.

7.1.1.2 Ignition Sources. Ignition temperatures for most fuel gases range from approximately 723°F to 1170°F (384°C to 632°C). Minimum ignition energies are as low as 0.2 mJ. Thus, they are easily ignited from most commonly encountered ignition sources.

The open flames of fuel gas burners or pilot lights can serve as competent ignition sources for fuel gases and other fuels, particularly flammable gases or the vapors of ignitable liquids and dusts.

Overheated fuel gas utilization equipment or improperly installed appliances or flue vents can cause the ignition of solid fuels, such as where wooden structural building components or improperly stored combustibles are involved, or where proper clearances are not maintained.

7.1.1.3 Both Fuel and Ignition Sources. On many occasions, the fuel gas piping and utilization systems, including burners and pilot lights, can serve as both the source of fuel and the ignition source.

7.1.2 Additional Fire Spread. During fire or explosion events, disrupted fuel gas systems can provide additional fuel and can greatly change or increase fire spread rates, or can spread fire to areas of the structure that would not normally be burned. The flames issuing from broken fuel gas lines (often called *flares*) can spread fire and burn through structural components.

Pockets of fuel gas that are ignited during the fire event can create evidence of separate fire origins, flash fires, or explosions, causing increased fire spread.

7.2* Fuel Gases. Fuel gases by definition include natural gas, liquefied petroleum gas in the vapor phase only, liquefied petroleum gas-air mixtures, manufactured gases, and mixtures of these gases, plus gas-air mixtures within the flammable range, with the fuel gas or the flammable component of a mixture being a commercially distributed product. The fuel gases most commonly encountered by the fire and explosion investigator will be natural gas and commercial propane.

7.2.1 Natural Gas. Natural gas is a naturally occurring largely hydrocarbon gas product recovered by drilling wells into underground pockets, often in association with crude petroleum. Though exact percentages differ with geographic areas, and there are no standards that specify its composition, natural gas is mostly methane, with lesser amounts of nitrogen, ethane, propane, and with traces of butane, pentane, hexane, carbon dioxide, and oxygen. The percentages may vary widely and have been reported in mixtures that range from 72 percent to 95 percent methane, 3 percent to 13 percent ethane, <1 percent to 4 percent propane, and <1 percent to 18 percent nitrogen.

Natural gas is lighter than air. Depending upon the exact composition, it has a vapor density of 0.59 to 0.72, a lower explosive limit (LEL) of 3.9 percent to 4.5 percent, and an upper explosive limit (UEL) of 14.5 percent to 15 percent. Its ignition temperature is 900°F to 1170°F (483°C to 632°C).

7.2.2 Commercial Propane. Propane is derived from the refining of petroleum. Liquefied petroleum gases can be liquefied under moderate pressure at normal temperatures. This ability to condense the LP-Gases makes them more convenient to store and ship than natural gas and thus makes propane particularly suitable for rural and relatively inaccessible areas or for use with portable equipment and appliances. In populated areas where natural gas is unavailable, propane is sometimes premixed with air and piped to consumers at relatively low pressures through central underground distribution systems similar to that of natural gas.

Commercial propane is a minimum of 95 percent propane and propylene and a maximum of 5 percent other gases. The average content of propylene in commercial propane is 5 percent to 10 percent.

Propane gas is heavier than air. It has a vapor density of approximately 1.5 to 2.0, a lower explosive limit (LEL) of 2.15 percent, and an upper explosive limit (UEL) of 9.6 percent. Its ignition temperature is 920°F to 1120°F (493°C to 604°C).

7.2.3 Other Fuel Gases. Other fuel gases that may be encountered by the investigator, particularly in commercial, industrial, or non dwelling settings, include commercial butane, propane HD5, and manufactured gases.

7.2.3.1 Commercial Butane. Commercial butane is a minimum of 95 percent butane and butylene and a maximum of 5 percent other gases, with the butylene component usually kept below 5 percent.

7.2.3.2 Propane HD5. Propane HD5 is a special grade of propane for motor fuel and other uses requiring more restrictive specifications than regular commercial propane. It is 95 percent propane and a maximum of 5 percent other gases.

7.2.3.3 Manufactured Gases. Manufactured gases are combustible gases produced from coal, coke, or oil; chemical processes; or by reforming of natural gas or liquefied petroleum gases or mixtures of such gases. They are most commonly used in industrial applications. The most common of the manufactured gases are acetylene, coke oven gas, and hydrogen.

7.2.4 Odorization. LP-Gas and commercial natural gas may not have a readily identifiable odor in their natural state. To increase the detectability of natural gas, an odorant blend containing *t*-butyl mercaptan, thiopane, or other mercaptans is usually added. To increase the detectability of LP-Gas, ethyl mercaptan or thiopane is usually added. These odorants are required by law and fire code; 49 *CFR* 129.625 states, "A combustible gas in a distribution line must contain a natural odorant or be odorized so that at concentration in air of one-fifth of the lower explosive limit, the gas is readily detectable by a person with a normal sense of smell." Subsection 1.3.1 of NFPA 58, *Liquefied Petroleum Gas Code*, states, "All LP-Gases shall be odorized prior to delivery to a bulk plant by the addition of a warning agent of such character that the gases are detectable, by a distinct odor, to a concentration in air of not over one-fifth the lower limit of flammability." The odorant for natural gas is added by the local distribution company prior to the introduction of the gas into the distribution system. Natural gas in long-distance transmission pipelines is usually not odorized. The odorant in LP-Gas is added by the gas supplier prior to delivery to an LP-Gas distributor's bulk plant.

Odorant verification should be a part of any explosion investigation involving or potentially involving fuel gas if it appears that there were no indications of a leaking gas being detected by people present. The odorant's presence, in the proper amount, should be verified. Specialized chemical detectors called *stain tubes* can be used in the field, and gas chromatography can be used as a lab test for more accurate results.

The utilization of stain tubes requires that the identity of the odorant in the gas be known, as there is no universal stain tube for all odorants. ASTM D 5305, *Standard Test Method for Determination of Ethyl Mercaptan in LP-Gas Vapor*, is a standard for propane odorant determination by stain tubes. There is no similar standard for natural gas odorants. A sample of the gas (or liquid for LP-Gas) requires that the sample be properly taken. ASTM D 1265, *Standard Practice for Sampling Liquefied Petroleum (LP) Gases (Manual Method)*, covers the proper method for sampling LP-Gas. The utilization of Tedlar® bags is suggested for natural gas samples that are to be used for odorant verification. Gas samples taken from a propane tank give only a fraction of the information that can be obtained from a liquid sample. Not all laboratories can analyze gases or liquids for odorant content. The ability of the lab to analyze this should be verified prior to sending the sample, as these samples should be analyzed as rapidly as possible.

Some individuals cannot detect these odorants for various reasons, and under certain conditions the odorant's effectiveness can be reduced to a point that it cannot be detected.

7.3 Natural Gas Systems. A difference between natural gas systems and propane systems is that natural gas is typically piped directly to the consumers' buildings from centralized production and storage facilities. The piping systems that deliver natural gas to the customer are quite complex, with many intervening procedures and pressure changes from collection to ultimate use.

7.3.1* Transmission Pipelines. Pipelines used to convey natural gas from storage or production facilities to local utilities are called *transmission pipelines*. In long-distance transmission pipelines, natural gas companies use pressures up to 1200 psi (8275 kPa).

7.3.2 Distribution Pipelines (Mains). Pipelines used to distribute natural gas in centralized grid systems for use by residential and business customers are called *distribution pipelines* or *mains*. Normal operating pressures in distribution pipelines vary widely among gas utility companies in different geographical areas. Pressures in distribution pipelines seldom exceed 150 psi (1035 kPa) in high-pressure systems and are typically 60 psi or less (414 kPa or less). Rural distribution systems, which must deliver gas to more distant customers, are necessarily at higher pressures than urban systems.

7.3.3 Service Lines. Natural gas service lines, sometimes called service laterals, are piping systems connecting the gas company's mains to the individual customer. They typically terminate at the regulator and utility meter. The minimum and maximum pressures delivered to customers' services after final pressure regulation are generally in the range of 4 in. to 10 in. w.c. (1.0 kPa to 2.5 kPa).

7.3.4 Metering. A gas meter is an instrument installed on a gas system to measure the volume of gas delivered through it. Depending on local rules, gas meters may be considered to be part of the gas utility company's service line or the property of the gas customer.

NFPA 54, *National Fuel Gas Code*, requires that gas meters be installed at least 3 ft (0.9 m) from sources of ignition and be protected from physical damage, extremes of temperature, overpressure, back pressure, or vacuum.

7.4 LP-Gas Systems. One difference between LP-Gas systems and natural gas systems is the storage and delivery of the fuel gases to the user's service piping. Typically, propane is delivered to the service customer's system in a compressed (liquid) state. It is delivered to the consumer by tank truck, with liquid transfer to the consumer's tank. In some isolated areas, where natural gas service is not available, underground propane or propane-air transmission and distribution piping systems similar to those discussed in Section 7.3 are used, though at generally lower pressures. Propane is the most commonly used LP-Gas, but butane and other LP-Gases or blends are used in some warm climates.

7.4.1 LP-Gas Storage Containers. LP-Gas storage containers may be cylinders, tanks, portable tanks, and cargo tanks. Specific definitions for these can be found in the various regulatory standards and guides. The American Society of Mechanical Engineers (ASME) and the Department of Transportation (DOT) are the two agencies that govern the design and fabrication of portable tanks and cylinders. Generally, *cylinders* refers to upright containers of 1000 lb (454 kg) water capacity or less and are governed by DOT regulations. Stationary tanks have greater than 1000 lb (454 kg) water capacity and are typically used as a fuel container for a residential or

commercial structure. These tanks are governed by ASME regulations. In storage containers, propane is kept under pressure in both the liquid and gaseous states. Normally, in residential use, the propane is drawn from the vapor space of the storage container.

Propane tanks and cylinders are typically designed with maximum working pressures of 200 psi to 250 psi (1379 kPa to 1724 kPa).

7.4.1.1* Tanks. Residential and small commercial systems generally store LP-Gas in aboveground ASME stationary tanks of up to 1000 gal (3.786 m³) water capacity, 800 gal to 900 gal (3.029 m³) LP-Gas capacity. Many localities place tanks underground in order to minimize problems with heat or cold.

7.4.1.2* Cylinders. Portable containers, usually referred to as DOT cylinders since they must conform to the regulations of the United States Department of Transportation, are commonly used for rural homes and businesses, mobile homes, motor fuel, recreational vehicles, and outdoor barbecue grills.

7.4.2 Container Appurtenances. Container appurtenances are items connected to container openings. These include, but are not limited to, pressure relief devices, connections for flow control, liquid level gauges, pressure gauges, and plugs.

7.4.2.1 Pressure Relief Devices. Pressure relief devices are designed to open to prevent a rise of internal fluid pressure in excess of a specified value [usually 250 psi (1724 kPa)] due to emergency or abnormal conditions, such as fire. LP-Gas containers are equipped with one or more relief devices that, except for certain DOT regulations, are designed to relieve vapor.

Fusible plug devices, which are designed to operate (open) at a certain temperature, also serve to release unsafe pressures. (See 7.4.2.5.)

Pressure relief devices include several types of internal and external pressure relief valves designed to open and close to maintain internal fluid pressure.

7.4.2.2 Connections for Flow Control. Shutoff valves, excess-flow check valves, backflow valves, and quick-closing internal valves used individually or in combinations are utilized at container filling, withdrawal, and equalizing connections.

7.4.2.3 Liquid Level Gauging Devices. Gauges indicate the level of liquid propane within a container. Gauge types include fixed, such as fixed maximum level, and variable, such as float or magnetic, rotary, and slip tube.

Fixed level gauges (i.e., dip tubes) are primarily used to indicate when the filling of a tank or cylinder has reached the maximum allowable fill volume of the container. They do not indicate liquid levels above or below their fixed lengths.

Variable gauges give readings of the liquid contents of containers, primarily tanks or large cylinders. They give readings at virtually any level of liquid volume.

7.4.2.4 Pressure Gauges. Pressure gauges, which are attached directly to a container opening or to a valve or fitting that is attached directly to a container opening, read the vapor space pressure of the container. Pressure gauges do not indicate the level of liquid within a container.

Pressure gauges are also used in various areas of system piping if needed.

7.4.2.5 Fusible Plugs. DOT cylinders must be equipped with pressure relief valves or fusible plugs. A fusible plug relieves

the pressure at a certain point and generally is not reusable and must be replaced. Aboveground ASME tanks of volumes less than 1200 lb (544 kg) water capacity may be equipped with fusible plug devices communicating directly with the vapor space and with a melting or yield point of 208°F (98°C) minimum and 220°F (104°C) maximum.

7.4.3 Pressure Regulation. Pressure in propane storage tanks and cylinders is the vapor pressure of the propane and is dependent on the temperature of the liquid propane. The vapor pressure gauge of propane ranges from 28 psi (193 kPa) at 0°F (-18°C), to 127 psi (876 kPa) at 70°F (21°C), to 286 psi (1972 kPa) at 130°F (54°C).

For use with utilization equipment, the pressure is typically reduced in one or two stages by regulators to a working pressure of 11 in. w.c. to 14 in. w.c. (2.74 kPa to 3.47 kPa) before entering the service piping system.

7.4.4 Vaporizers. Where larger quantities of propane are required, such as for industrial applications, or where cold weather will hamper vaporization, specifically designed heaters called vaporizers are used to heat and vaporize the propane.

7.5 Common Fuel Gas System Components. Fuel gas delivery system components are common or similar for the various fuel gases. The following sections describe in general these commonly shared components.

7.5.1 Pressure Regulation (Reduction). Pressure regulators are devices placed in a gas line system for reducing, controlling, and maintaining the pressure in that portion of the piping system downstream of the device. Regulators can be used singly or in combination to reduce the gas line pressures in stages.

The most common regulators in natural gas or propane consumer service are of the diaphragm, or lever, type. In a diaphragm regulator, the flow of the inlet gas at high pressure is controlled by a shutoff disc, or seal, and gas at a specific lower pressure is discharged through the regulator outlet. The diaphragm is made of a rubberlike material, and its movement is controlled by adjustable spring pressure. Movement of the diaphragm controls the opening of the regulator inlet valve and its integral seal.

The proper operation of the regulator vent is important to the proper operation of diaphragm regulators. The vent equalizes the pressure above the diaphragm with atmospheric pressure and allows the diaphragm to move. If the vent becomes clogged or blocked, such as by ice or debris, the regulator may not operate properly or the rubberlike diaphragm material may be damaged, preventing proper operation.

In flood-prone areas, pressure regulators should be installed above the expected flood line, or the vent should be piped above the flood line. Flood waters filled with flood debris, such as mud, sticks, and trash, can easily clog or block the regulator vent. These conditions can result in an overpressure condition at downstream piping and at the gas appliance.

7.5.1.1 Normal Working Pressures. Normal working pressures in most structures and appliances are measured in inches of water column (w.c.), measured on a water-filled manometer. One pound per square inch gauge (psi) is equal to 2.767 in. of water column. Normal inlet pressure for most nonindustrial natural gas appliances is 4 in. w.c. to 10 in. w.c. (1.0 kPa to 2.5 kPa). Normal inlet pressure for most nonindustrial propane appliances is 11 in. to 14 in. w.c. (2.74 kPa to 3.47 kPa).

7.5.1.2 Excess Pressures. Pressures significantly in excess of those for which appliances, equipment, devices, or piping systems are designed can cause gas leakage, damage to equipment, malfunction of equipment burners, or abnormally large flames.

7.5.2 Service Piping Systems.

7.5.2.1 Materials for Mains and Services. Fuel gas piping may properly be made of wrought iron, copper, brass, aluminum alloy, or plastic, as long as the material is used with gases that are not corrosive to them. Unapproved tubing or piping materials utilized in “not-to-code,” homemade applications may lead to leaks and the release of fugitive gas.

7.5.2.2 Underground Piping. Improper installation of underground piping systems and use of unapproved materials may be a cause of gas leaks. Underground piping must be buried to a sufficient depth and in appropriate locations to be protected from physical damage. The pipe must be protected against corrosion. Underground piping under buildings may be acceptable, if unavoidable, but must be protected and encased in approved conduit designed to withstand the superimposed loads of the structure and contain any gas leakage.

7.5.3 Valves. Valves are devices used to control the gas flow to any section of a system or to an appliance. Examples of valve types include the following.

(a) *Automatic Valves.* Devices consisting of a valve and operating mechanism that controls the gas supply to a burner during operation of an appliance. The operating mechanism may be activated by gas pressure, electrical means, or mechanical means.

(b) *Automatic Gas Shutoff Valve.* A valve used in connection with an automatic gas shutoff device to shut off the gas supply to a fuel gas burning appliance.

(c) *Individual Main Burner Valve.* A valve that controls the gas supply to an individual main burner.

(d) *Main Burner Control Valve.* A valve that controls the gas supply to a main burner manifold.

(e) *Manual Reset Valve.* An automatic shutoff valve installed in the gas supply piping and set to shut off when unsafe conditions occur. The device remains closed until manually reset.

(f) *Relief Valves.* A safety valve designed to prevent the rupture of a pressure vessel by relieving excess pressure.

(g) *Service Shutoff Valve.* A valve (usually installed by the utility gas supplier between the service meter or source of supply and the customer piping system) used to shut off gas to the entire piping system.

(h) *Shutoff Valve.* A valve (located in the piping system and readily accessible and operable by the consumer) used to shut off individual appliances or equipment.

7.5.4 Gas Burners. Problems with fuel gas systems, including fires, are often caused by use of the inappropriate orifices or burners for natural gas or propane. Gas burners are devices for the final conveyance of the fuel gas, or a mixture of gas and air, to be burned. Though the several types of burners in common use are essentially the same in general design for both natural gas or propane, they may not be interchangeable from one gas usage to another. Physical differences between natural gas and propane require different sized burner orifices.

7.5.4.1 Manual Ignition. Some gas appliances and equipment are designed to require the manual ignition of their burners when utilization of the appliances and equipment is

desired. Some equipment furnished with a standing pilot light requires that the pilot light be ignited manually.

7.5.4.2 Pilot Lights. Automatic ignition of main burners on appliances is frequently accomplished by a pilot burner flame. For automatic operation by a thermostat, as on automatic water heaters and central heating appliances, the gas pilot flame must be burning and of sufficient size; otherwise, the valve controlling main burner gas flow will not open.

In some designs, pilot lights themselves may be ignited automatically by electric arcs activated when gas is called for at the burner.

7.5.4.3 Pilotless Igniters. This type of ignition system consists of an electric ignition means, an electric arc, or a resistance heating element such as a glow plug or a glow bar that directly ignites the burner flame when gas flow begins. On failure to ignite, many, but not all, systems are designed to “lock out” the flow of gas to the burner.

7.6 Common Piping in Buildings. There are several considerations or requirements for the installation and use of fuel gas piping systems in buildings that are common no matter which fuel gases are used.

7.6.1 Size of Piping. The size of piping used is determined by the maximum flow requirements of the various appliances and equipment that it services.

7.6.2 Piping Materials. Piping may be made of wrought iron, copper, brass, aluminum alloy, or plastic, as long as the material is used with gases that are not corrosive to them. Flexible tubing may be of seamless copper, aluminum alloy, or steel. Aluminum alloy tubing is generally considered to be not suitable for underground or exterior use. Plastic pipe, tubing, and fittings are to be used for outside underground installations only.

7.6.3 Joints and Fittings. Piping joints may be screwed, flanged, or welded, and nonferrous pipes may be soldered or brazed. Tubing joints may be flared, soldered, or brazed. Special fittings such as compression fittings may be used under special circumstances.

Outdoors, plastic piping joints and fittings may be made, with the appropriate adhesive method or by means of compression fittings, compatible with the piping materials. They are not to be threaded.

7.6.4 Piping Installation. When installed in buildings, gas piping should not weaken the building structure, should be supported with suitable devices (not other pipes), and should be protected from freezing. Drip pipes (drip legs) must be provided in any areas where condensation or debris may collect. Each gas outlet, including valve or cock outlets, should be securely capped whenever no appliance is connected.

7.6.5 Main Shutoff Valves. Accessible shutoff valves must be placed upstream of each service regulator in order to provide for a total shutdown of an entire piping system.

7.6.6 Prohibited Locations. NFPA 54, *National Fuel Gas Code*, prohibits the running of gas piping in or through circulating air ducts, clothes chutes, chimneys or gas vents, ventilating ducts, dumbwaiters, or elevator shafts. Fugitive gas in these prohibited areas is particularly dangerous because of the chances for widespread distribution of the leaking gas and the increased possibilities for accidental ignition.

7.6.7 Electrical Bonding and Grounding. Every aboveground portion of the piping system must be electrically bonded and the system grounded.

7.7 Common Appliance and Equipment Requirements. There are several considerations or requirements for the installation and use of fuel gas appliances that are common no matter the fuel gases used in the appliances.

7.7.1 Installation. The basic requirements for the installation of domestic, commercial, and industrial fuel gas appliances and equipment supplied at gas pressures of 0.5 psi (14 in. w.c.) (3.47 kPa) or less are similar.

7.7.1.1 Approved Appliances, Accessories, and Equipment. Subsection 5.1.1 of NFPA 54, *National Fuel Gas Code*, requires that “gas appliances, accessories, and gas utilization equipment shall be approved . . . acceptable to the authority having jurisdiction.”

7.7.1.2 Type of Gas. Fuel gas utilization equipment must be used with the specific type of gas for which it was designed. A particular appliance cannot be used interchangeably with natural gas and propane without appropriate alteration.

7.7.1.3* Areas of Flammable Vapors. Gas appliances are not to be installed in residential garage locations where flammable vapors are likely to be present, unless the design, operation, and installation are such as to eliminate the probability of ignition of such vapors. For example, NFPA 54, *National Fuel Gas Code*, requires gas utilization equipment installed in garages to be installed with the burners and ignition devices not less than 18 in. (0.5 m) above the floor. Though not directly prohibited by the codes, installations below 18 in. (0.5 m) in other areas of buildings and dwellings have been found to be responsible for fires and injuries.

7.7.1.4 Gas Appliance Pressure Regulators. When the building gas supply pressure is higher than that at which the gas utilization equipment is designed to operate or varies beyond the design pressure limits of the equipment, a gas appliance pressure regulator is installed in the appliance.

7.7.1.5 Accessibility for Service. All gas utilization equipment should be located so as to be accessible for maintenance, service, and emergency shutoff.

7.7.1.6 Clearance to Combustible Materials. Gas utilization appliances and their vents should be installed with sufficient clearance from combustible materials so that their operation will not create a fire hazard.

7.7.1.7 Electrical Connections. All electrical components of gas utilization equipment should be electrically safe and comply with NFPA 70, *National Electrical Code*.

7.7.2 Venting and Air Supply. Venting is the removal of combustion products as well as process fumes (e.g., flue gases) to outer air. Although most fuel gases are clean-burning fuels, the products of combustion must not be allowed to accumulate in dangerous concentrations inside a building. Therefore, venting to the exterior is required for most appliances. Examples of appliances that require venting include furnaces and water heaters. Some appliances, such as ranges, ovens, and small space heaters, are allowed to be vented directly into interior spaces. A properly installed venting system should convey all the products of combustion gases to the outside; should

prevent damage from condensation to the gas equipment, vent, building, and furnishings; and should prevent overheating of nearby walls and framing.

Gas utilization equipment requires an air supply for combustion and ventilation. Restriction of this air supply, particularly when equipment is installed in confined spaces, can result in overheating, fires, or asphyxiation.

7.7.3 Appliance Controls. General categories of appliance controls are the same for nearly all fuel gas appliances. Failure in these controls can lead to the overheating of appliances or the uncontrolled release of gas or flame. These common controls include the following:

- (1) Temperature controls
- (2) Ignition and shutoff devices
- (3) Gas appliance pressure regulators
- (4) Gas flow control accessories

7.8* Common Fuel Gas Utilization Equipment. All fuel gas systems ultimately employ the gases by burning them. The utilization of fuel gases in structures falls into seven main areas of domestic, commercial, or industrial use, each of which involves the combustion of the fuel gas.

Common fuel gas utilization equipment includes the following.

(a) *Air Heating.* Forced air furnaces, space heaters, floor furnaces, wall heaters, radiant heaters, duct furnaces, or boilers are used for heating of environmental air; direct or indirect burners are used for industrial ovens, dryers and heating of processes and materials, clothing and fabric dryers, both domestic and industrial.

(b) *Water Heating.* Direct flame burners are used for the heating of potable or industrial process water.

(c) *Cooking.* Ranges, stove-top burners, broilers, and cooking ovens, domestic and industrial, are used for cooking.

(d) *Refrigeration and Cooling.* Fuel gases are often used as the energy sources for absorption system refrigeration and cooling systems.

(e) *Engines.* Fuel gases are commonly used as fuel sources for stationary and motor vehicle engines and for auxiliary power units on service vehicles, such as to power pumps on tank trucks. Stationary engines fueled by fuel gases are commonly used as auxiliary or emergency motors for electrical power generation or fire pumps.

(f) *Illumination.* Though commonly used for illumination in the early part of this century, most fuel gas illumination systems have been replaced by electricity. The most common exception is gas lamps used for outdoor lighting. Principal residential lighting applications include yards, patios, driveways, porches, play areas, and swimming pools. Commercial applications include streets, shopping centers, airfields, hotels, and restaurants. These illumination uses of fuel gases include ornamental gas flames for memorials or decorative effects. These systems often involve underground fuel lines, which may not be buried deep enough or protected sufficiently from external damage.

(g) *Incinerators, Toilets, and Exhaust Afterburners.* Gas-fired domestic, commercial, industrial, and flue-fed incinerators, toilets, and exhaust afterburners are used to burn rubbish, refuse, garbage, animal solids, and organic waste, as well as gaseous, liquid, or semisolid waste from industrial processes.

7.9 Investigating Fuel Gas Systems. Once it has been determined that a fuel gas system has influenced the way a building has burned, either as a fuel source, ignition source, as both a fuel and ignition source, or by providing additional fire spread, the system should be analyzed. This analysis should provide information as to the manner of and extent to which the fuel gas system may have been involved in the origin or cause of the fire or explosion.

7.9.1 Systematic Analysis. Such an analysis should be a systematic examination of the fuel gas system. Each component of the system should be evaluated to determine whether, and to what extent, it operated or failed.

7.9.2 Compliance to Codes and Standards. The NFPA *National Fire Codes*[®], as well as many other fire codes and gas industry standards, specify a wide variety of safety rules for the installation, maintenance, servicing, and filling of fuel gas systems. Failure to comply with one or more of these standards can cause or contribute to a fuel gas fire or explosion incident.

The design, manufacture, construction, installation, and use of the various components of the fuel gas system should be evaluated for compliance to the appropriate codes and standards. Any relationship between a violation of the accepted codes and standards and the fire or explosion should be noted.

7.9.3 Leakage. Leakage from piping and equipment is the main cause of gas-fueled fires and explosions. Commonly, leaks occur at pipe junctions, at unlit pilot lights or burners, at uncapped pipes and outlets, at areas of corrosion in pipes, or from physical damage to the gas lines.

7.9.3.1 Pipe Junctions. Improper connections between piping elements, such as inadequate threading (not enough turns for gas tightness), improper threading (cross threading or right-hand threads merged to left-hand threads), or improper use of pipe joint compound (too much or too little) can cause gas leaks. Pipe junctions are also the most common locations that leak as a result of physical damage to fuel gas piping systems. (See 7.9.3.8.)

7.9.3.2 Pilot Lights. Modern pilot light systems are designed to prevent gas flow to appliance burners if the pilot lights are not burning by the use of a thermocouple to sense the pilot flame. Such pilots could remain open if their automatic shut-off mechanisms failed to close off the flow of gas. The escape of gas from unlit pilots is not large enough to produce gas volumes sufficient to fuel significant fires or explosions, except in spaces that have little or no ventilation. Many modern appliances have pilot light systems that will not allow a flow of gas unless the pilots are lit, or else they have electronic ignition systems not requiring pilot lights at all.

7.9.3.3 Unlit Burners. In some gas appliance systems, a burner may emit gas even if the pilot light is not lit. This generally will produce enough gas to fuel an explosion or fire even in well-ventilated rooms or structures.

7.9.3.4 Uncapped Pipes and Outlets. A common source of large quantities of fugitive gas is open, uncapped pipes and outlets. Such situations occur when gas appliances are removed and their attendant outlet or piping is not capped as is required by the NFPA 54, *National Fuel Gas Code*. Unsuspecting persons then turn on the gas from remote valves. This causes high-volume leaks.

7.9.3.5 Malfunctioning Appliances and Controls. The malfunction and leaking of gas appliances or gas utilization controls, such as valves, regulators, and meters, can also produce fugitive gas. Often fittings and piping junctions within appliances can be sources of leakage. Shutoff valves may leak fugitive gas through the packing materials that are designed to seal the valve bodies from the activation levers. Valves may allow gas to pass through them when they should be closed, due to dirt or debris in their operating mechanisms or due to physical damage or binding of the mechanisms.

7.9.3.6 Regulators. Failures in gas regulators most often fall into one of three categories: faults with the internal diaphragm, faults with the rubberlike seal that controls the input of gas into the regulator, or faults with vents. Each of these fault categories can result in the regulator's failing to reduce the outlet pressure to acceptable levels or producing fugitive gases.

7.9.3.7 Corrosion. Metal pipes are subject to corrosion. Corrosion has been reported to be the cause of as many as 30 percent of all known gas leaks. Corrosion can be caused by oxidation of ferrous metal pipes (rust); electrolysis between dissimilar metals, metal and water, metal and soil, or stray currents; or even microbiological organisms. Corrosion can take place either above or below ground level and can subsequently release fugitive gas.

Since the size of corrosion leaks is cumulative as the corrosion continues, it may take long periods of time for the corrosion leaks to develop to sufficient size to produce enough fugitive gas to overcome the dissipating effects of ventilation or dispersion through the soil into the air.

Stress corrosion cracking of flexible brass appliance connectors has been shown to be a factor in many residential fires and explosions.

7.9.3.8* Physical Damage. Physical damage to fuel gas systems can cause leaks. Strain put on gas piping systems may manifest itself at the pipe junctions and unions. Because pipe elbows, T fittings, and couplings are more rigid and stronger than the pipes that they connect, and because the threaded ends are weaker than the rest of the pipes, stress damage usually occurs in the threaded portions of the pipes immediately adjacent to the pipe fittings.

The leaks created by such strain may develop at junctions far removed from the actual point of physical contact. For example, if an automobile strikes a gas meter assembly, the strain on the underground piping of the system may cause a leak at a distant, underground pipe union many feet away. The movement of a gas range away from a wall may strain the gas piping system and cause a leak at the junction of the flexible tubing and the rigid main gas line or at a junction within the range itself.

Hidden pipes underground and in walls are often damaged by construction work. Pipes have been pierced by digging tools, nails, screws, drill bits, cutting tools, and other tools. When nails or screws pierce gas pipes, the resulting leak holes may be largely plugged and remain so until the nail or screw is removed or dislodged, such as by settling of the structure. Therefore, leaks from nails and screws may remain undetected until long after the original damage.

7.9.4 Pressure Testing. Fuel piping systems are designed to retain moderately pressurized gas. The presence of leaks in the system can be determined by detecting a drop in pressure within the closed system. Before the piping is used for such

testing, any obviously damaged portions of the system should be isolated and capped. Sometimes it will be necessary to test the piping in two or more sections, one at a time.

When isolating portions of the piping that have been damaged by fire or explosion damage, it may be necessary to cut, rethread, and cap individual pipes. It may be possible to seal off damaged piping sections by the use of flexible tubing, hose clamps, and caps, without the necessity to rethread and cap lines. Screw junctions, unions, Ts, or elbows should not be unscrewed in order to isolate a section. Doing so may destroy evidence of previously existing poor connections.

7.9.4.1 Gas Meter Test. If it is decided that it is safe to use the actual fuel gas of the system, the gas meter itself can be used to detect a flow of gas. After first checking that the meter is working properly and has not been damaged by the explosion or fire or bypassed, gas is reintroduced into the system through the meter, and the dial is observed to determine whether gas is escaping somewhere downstream. The meter should be observed with the needle on the upstroke, and observation should continue for up to 30 minutes.

NFPA 54, *National Fuel Gas Code*, recommends that if no leak is detected with the gas meter test, the test should be repeated with a small gas burner open and ignited, which will show whether the meter is working properly.

7.9.4.2* Pressure Drop Method. A gas piping system may also be tested by the pressure drop method. In this method, the system is pressurized with air or an inert gas such as nitrogen or carbon dioxide. For systems including appliances operating at gauge pressures of $1\frac{1}{2}$ psi (3.4 kPa) or less, the test can be conducted with the fuel gas itself at between 10 in. and 14 in. (2.5 kPa and 3.5 kPa) of water column for 10 minutes. Test methods are listed in NFPA 54, *National Fuel Gas Code*, and NFPA 58, *Liquefied Petroleum Gas Code*.

7.9.5 Locating Leaks. Leaks in fuel gas piping may be located by one or more of the methods in 7.9.5.1 through 7.9.5.4.

7.9.5.1 Soap Bubble Test. Leaks at pipe junctions, fittings, and appliance connections can be detected by applying soap bubble solutions to the suspected leaking area. If the system is pressurized, the production of bubbles in the solution will disclose the leak. After testing, the area should be rinsed with water to prevent possible corrosion or stress cracking.

7.9.5.2 Gas Detector Surveys. Gas detection instruments, known as flammable gas indicators, combustible gas indicators, explosion meters, or "sniffers," may be used as survey devices to detect the presence of fugitive fuel gases, hydrocarbon gases, or vapors in the atmosphere. Many instruments will also detect the presence of other combustible gases or vapors such as ammonia, carbon monoxide, and others, so the operator should be fully aware of the capabilities and limitations of the instrument being used.

On the outside of structures, the atmosphere is tested in every available opening in the pavement where gas that has escaped from mains and service lines may be present. Tests should be made along pavement cracks, curb lines, manholes and sewer openings, valve and curb boxes, catch basins, and in bar holes above and along gas piping runs.

The location of underground gas lines can be learned from utility company maps or by the use of an electronic locator device. These devices induce electromagnetic waves into the earth. Any metallic pipe in the wave field acts as a path for return current and is picked by the receiving unit of the device. An audio tone or analog meter needle then indicates

the presence of an underground line. When plastic pipes are used, a metallic locating wire is usually buried along with the pipe to allow the locator devices to be utilized.

Within structures, the junctions and unions of gas piping can be tested. Spaces where fugitive gases may collect and pocket should also be tested. The relative vapor density of the fuel gases should be kept in mind. If lighter-than-air natural gas is suspected, upper areas of the rooms in structures should be tested. If heavier-than-air LP-Gas is suspected, lower levels should be checked.

7.9.5.3 Bar Holing. Bar holes are holes driven into the surface of the ground or pavement with either weighted metal bars or drills. Bar holing involves the systematic driving of holes at regular intervals along the path of and to either side of underground gas lines and the testing of the subsurface atmosphere with a gas detector. The results of these tests are recorded on a graph or chart known as a bar hole graph. A comparison of the readings of percentage of fugitive gas from each bar hole can indicate the location of an underground gas leak.

7.9.5.4 Vegetation Surveys. Over a period of time, some of the components of fugitive fuel gases from underground leaks can be harmful to grass, trees, shrubs, and other vegetation. When the root systems of plants are subjected to gas from underground leaks, the plants may turn brown, be stunted in their growth, or die. Long-existing underground leaks, which have been permeating the soil and dissipating into the air, may be located by the presence of dead grass or other vegetation over the area of the leak.

7.9.6 Testing Flow Rates and Pressures. If regulators or other gas appliance and service components have not been severely damaged by fire, they can be tested to see whether they are functioning correctly. These tests can be conducted with a variety of gases including air, natural gas, propane, or butane. With the use of proper laboratory or field equipment, both lockup and flow pressures as well as normal or leak flow rates can be determined. In such tests, the resultant data must be adjusted from the test medium gas to the gases for which the devices were designed. These adjustments are based on the relative vapor densities of the gases.

7.9.7* Underground Migration of Fuel Gases. It is common for fuel gases that have leaked from underground piping systems to migrate underground (sometimes for great distances), enter structures, and create flammable atmospheres. Both lighter-than-air and heavier-than-air fuel gases can migrate through soil; follow the exterior of underground lines; and seep into sewer lines, underground electrical or telephone conduits, drain tiles, or even directly through basement and foundation walls, none of which are as gastight as water or gas lines.

Such gases also tend to migrate upward, permeating the soil and dissipating harmlessly into the atmosphere. Whether the path of migration is lateral or upward is largely a matter of which path provides the least resistance to the travel of the fugitive gas, the depth at which the leak exists, the depth of any lateral buried lines that the gas might follow, and the nature of the surface of the ground. If the surface of the ground is obstructed by rain, snow, frozen earth, or paving, the gases may be forced to travel laterally. It is not uncommon for a long-existing leak to have been dissipating harmlessly into the air until the surface of the ground changes, such as by the installation of new paving or by heavy rains or freezing, and then be forced to migrate laterally and enter a structure, fueling a fire or explosion.

7.9.7.1* Odorant Removal from Gas. An odorized gas can lose odorant by a number of different mechanisms. This odorant loss has also been termed *odor fade*. This is a complex subject and for a deeper understanding the reader is referred to the references cited in Appendix B. The following paragraphs summarize some of the important issues in odorant loss.

(a) *Loss of Odorant Due to Gas Migration in Soil.* Gas odorants can be removed by dry, clay-type soils, and not by sand, loams, or heavily organic soils. Certain odorant components are better than others in terms of their ability to resist absorption by clay-type soils. A large leak gives a lower contact time with the clay-type soil, and results in lower losses due to adsorption.

(b) *Loss of Odorant Due to Adsorption of Odorant on Pipe Walls.* All odorant components are adsorbed by pipe walls to some extent. This is particularly true of new pipe (steel or plastic). Many natural gas companies treat the gas in new sections to a heavier dose of odorant after the section is placed in service. Gas odorants can be adsorbed in gas pipe that has been in continuous service, if the flow rates of gas are lower than normal. This is a typical condition in many gas companies in the transition between winter and summer usage levels. A decrease in pressure in the system, which increases gas flow rates, easily remedies this problem. Any portion of a gas system that is subject to low flow rates is subject to increased loss of odorant due to adsorption.

(c) *Loss of Odorant Due to Oxidation of Odorant.* Mercaptan odorants can be oxidized by ferric oxide (red rust), which can be found in new pipe and in new or out-of-service LP tanks.

(d) *Loss of Odorant Due to Adsorption.* Adsorption is a phenomenon that requires the dissolution of odorant in a liquid. It can occur in natural gas systems that have a problem with liquid condensates in their distribution lines. The most common liquid available in the environment is water. All odorants have a low solubility in water.

Chapter 8 Fire-Related Human Behavior

8.1 Introduction. The initiation, development, and consequences of many fires and explosions are either directly or indirectly related to the actions and omissions of people associated with the incident scene. As such, the analyses of fire-related human behavior will often be an integral part of the investigation.

This chapter discusses research findings associated with factors that contribute to such human behavior: how people react to fire emergencies, both as individuals and in groups; factors related to fire initiation; factors related to fire spread and development; factors related to life safety; and factors related to fire safety.

The information discussed in this chapter is based upon research conducted by specialists in the fire scene analysis and human behavior fields. The analysis of human behavior is not a substitute for a thorough and properly conducted investigation. While the analysis of human behavior will provide valuable investigative insights, such analysis must be integrated into the total investigation.

8.2 History of Research. Fire-related human behavior began to emerge as a distinct field for study in the early 1970s. In 1972, English researcher Peter G. Wood, a pioneer in the field, completed a study of occupants in 952 fire incidents, published as Fire Research Note #953. A few years later, John L. Bryan, a U.S. researcher and professor of fire protection

engineering at the University of Maryland, published the results of his extensive studies on behavior in fires. Bryan has summarized both his work and much of the work of other researchers in this field. This summary is contained in the SFPE *Handbook of Fire Protection Engineering*, "Behavioral Response to Fire and Smoke."

8.3 General Considerations of Human Responses to Fires. Current accepted research indicates that there are myriad factors that affect an individual's or group's human behavior preceding, during, and following a fire or explosion incident. These factors can be broadly classified and evaluated as characteristics of the individual, characteristics of population groups, characteristics of the physical setting, and characteristics of the fire or explosion itself. A careful analysis and evaluation of these factors and their interaction with one another will provide a valuable insight into the role of fire-related human behavior for any particular incident. These factors have been extensively examined in the U.S. Fire Administration publication, *Fire Related Human Behavior*, 1994 edition. This information is summarized in 8.3.1 through 8.3.2.4.

8.3.1 Individual. Fire-related human behavior is affected by characteristics of the individual in a variety of ways. These characteristics are comprised of physiological factors, including physical limitations, cognitive comprehension limitations, and knowledge of the physical setting. Each of these either affect an individual's ability to recognize and accurately assess the hazards presented by a fire or explosion incident or affect an individual's ability to respond appropriately to those hazards.

8.3.1.1 Physical Limitations. Physical limitations that may affect an individual's ability to recognize and react appropriately to the hazards presented by a fire or explosion incident include age (as it relates to mobility), physical disabilities, intoxication, incapacitating or limiting injuries or medical conditions, and other circumstances that limit an individual's mobility. Such limitations should be considered when evaluating an individual's fire-related human behavior because they tend to restrict or limit one's ability to take appropriate action in response to a fire or explosion. The very old and very young are most affected by physical limitations.

8.3.1.2 Cognitive Comprehension Limitations. Cognitive comprehension limitations, which may affect an individual's ability to recognize and react appropriately to the hazards presented by a fire or explosion incident, include age (as it relates to mental comprehension), level of rest, alcohol use, drug use (legal or illegal), developmental disabilities, mental illness, and inhalation of smoke and toxic gases. These cognitive limitations are more likely to affect an individual's ability to accurately assess the hazards presented by a fire or explosion. Often such limitations account for delayed or inappropriate responses to such hazards.

Children may fail to recognize the hazard and choose an inappropriate response, such as hiding or seeking a parent.

8.3.1.3 Familiarity with Physical Setting. An individual's familiarity with the physical setting in which a fire or explosion incident occurs may affect an individual's behavior. For example, a person would be more able to accurately judge a fire's development and progression in his or her own home than in a hotel.

It is important to note, however, that physical and cognitive limitations may minimize the advantages of being familiar with the physical setting. Consequently, it may appear that a person has gotten "lost" in their own home.

8.3.2 Groups. An individual's fire-related behavior is affected by more than his or her own characteristics. When interacting with others, an individual's behavior will likely change and be further affected by his or her interaction with that population group and its characteristics. These group characteristics are related to the group size, structure, permanence, and its roles and norms.

8.3.2.1* Group Size. Research and experimental data indicate that when individuals are members of a group, they are less likely to acknowledge or react appropriately to the sensory cues that a fire or explosion incident presents. This tendency increases as the size of the group increases.

Research suggests that this fire-related human behavior occurs because individuals in groups will delay their response to such sensory cues until others in the group also acknowledge these cues and react. The same research suggests that this occurs because the responsibility for taking appropriate action is actually diffused among the group.

8.3.2.2* Group Structure. The structure of a group may also affect the fire-related behavior of both the group and its individual members. Generally, when the group has a formalized structure with defined and recognized leaders or authority figures, the group tends to react to fire and explosion incidents more quickly and in a more orderly manner. However, the reaction is not always appropriate. Examples of such groups include school populations, hospital populations, nursing home populations, and religious facility populations. The following behaviors have been observed.

(a) Research indicates that the interaction between individual members within such groups results in a sense of responsibility for the group as a whole. As such, an individual may be more likely to warn the others in his or her group of the threat than if he or she were interacting with a group of strangers.

(b) Secondly, when such a group does become aware of a fire or explosion, their requisite organization and cohesiveness will likely result in a more orderly response to any such threat.

8.3.2.3 Group Permanence. Group permanence refers to how well established a group is or how long a particular group of individuals has interacted with one another. Closely related to the effects of group structure, the permanence of a group may also affect the behavior of both the group and its individual members.

Research indicates that more established groups (such as family, sports teams, or clubs) will be more formalized and structured and, therefore, will react differently during a fire or explosion incident than will a new or transient group (such as a shopping mall population). The latter is more likely to exhibit a multitude of conflicting individual behaviors as each group member responds and reacts on his or her own.

8.3.2.4 Roles and Norms. The roles and norms of a group also affect its fire-related behavior. The norms of a group may be influenced by gender, social class, occupational, or educational makeup.

Gender roles are often a predominant factor during fire and explosion incidents. Research indicates, for example, that women are more likely to report a fire or explosion immediately, while their male counterparts may delay reporting the incident, opting rather to engage in suppression or other mitigation efforts.

8.3.3 Characteristics of the Physical Setting. The characteristics of the physical setting in which a fire occurs affect the development and the spread of a fire or explosion. The characteristics of the setting also affect fire-related behavior. Examples of these characteristics include location of exits, number of exits, the structure's height, fire-warning systems, and fire suppression systems.

8.3.3.1 Location of Exits. The location of available exits during a fire or explosion incident may affect the behavior of the occupants. If the locations of the available exits are not known to the occupants, or if they are not adequately identified, confusion and heightened levels of anxiety may be experienced.

8.3.3.2 Number of Exits. The number of available exits during a fire or explosion incident may affect the behavior of the occupants. An inadequate number of exits, blocked or restricted exits, and unprotected exits (i.e., nonpressurized or open interior stairwells) may result in the occupants being exposed to the fire and its by-products.

8.3.3.3 Height of Structure. The height of a structure may affect the behavior of its occupants during a fire or explosion incident. Some people believe that they are less safe in taller buildings during fire incidents.

8.3.3.4* Fire Alarm Systems. Fire alarm systems are among the variables of built-in fire safety that may be critical to an individual's awareness of a fire. Research has shown that verbal, directive messages may be most effective in creating response compared to alarm bells and sounders alone.

Prior false alarms and alarm system malfunctions may reduce the positive effect of having an alarm system in the building, because the occupants may not respond appropriately to the alarm notification. Numerous false alarms reduce the occupants' appropriate responses to the alarm.

8.3.3.5 Fire Suppression Systems. The presence of automatic fire suppression systems, if known, may affect behavior. The effect may be positive or negative. A positive effect is that the increased margin of safety such systems provide allows occupants of the involved structure more time to respond appropriately to the hazards presented by the incident. An example of a negative effect is possible decreased visibility, caused by the discharge of the suppression agent, which may impede egress.

8.3.4 Characteristics of the Fire. Fire-related human behavior is directly related to an individual's or group's perception of the hazards or threats presented to them by a fire or explosion. Characteristics of the fire itself will tend to shape these perceptions and thereby affect fire-related human behavior. Examples of these characteristics include the presence of flames or smoke and the effects of toxic gases and oxygen depletion.

8.3.4.1 Presence of Flames. Most individuals have uneducated or uninformed perceptions of the hazards presented by fire and explosion incidents. This perception problem is especially true relative to an individual's observation of the presence of visible flames. The sight of flames makes the individual aware that it is not a false alarm and that some danger is present; however, because people do not understand fire dynamics and fire behavior, the presence of small flames may not be recognized as an immediate threat, and the resulting behavior is based on that belief. See Chapter 3 for further discussion on fire dynamics.

8.3.4.2 Presence of Smoke. Like visible flames, the presence of smoke may also affect fire-related behavior. A lack of knowledge regarding fire dynamics and fire behavior may result in erroneous perceptions relative to smoke. Individuals may perceive dense, black smoke as an immediate threat to their physical well being, while light, gray smoke may not be immediately perceived as a threat at all.

8.3.4.3 Effects of Toxic Gases and Oxygen Depletion. During fire and explosion incidents, individuals often inhale the by-products of combustion, including the toxic gases present in the smoke. Additionally, the development and progression of the fire, as well as the presence of these other gases, often results in a depletion of the oxygen that had originally been present in the ambient air.

The inhalation of toxic gases, or low oxygen concentration levels below approximately 15 percent, may affect an individual's behavior and result in perceptual and behavioral changes. These changes may manifest themselves in delayed or inappropriate responses to the incident. Strength, stamina, mental acuity, and perceptual ability can all be severely decreased. See 20.5.5.

8.4 Factors Related to Fire Initiation. The initiation of many fire and explosion incidents is facilitated or fostered by the actions or omissions of people associated with the incident scene. Fire-related human behavior is often the reason that a competent source of ignition is present at the same time and place with a fuel in the presence of a sufficient amount of oxygen.

8.4.1 Factors Involved in Accidental Fires. The actions or inactions of people frequently result in accidental fires.

Negligence, carelessness, lack of knowledge, disregard of fire safety principles, or the individual's failure to be cognizant of the ultimate results of such actions or inactions can be categorized into groups of similar behavior. Examples of these groupings are improper maintenance; poor housekeeping; issues involving product labels, instructions and warnings; and violations of fire safety codes and standards.

8.4.1.1 Improper Maintenance and Operations. Many types of equipment, systems, machinery and appliances are potential ignition sources or fuel sources for fire and require some level of periodic maintenance or cleaning. Instructions pertaining to the type of maintenance or cleaning procedures, as well as a recommended schedule for maintenance or cleaning are most often provided by the manufacturer or supplier. Failure to adhere to these recommendations may result in fire or explosion. It is often reported to the investigator that the accompanying maintenance or cleaning instructions to a specific piece of equipment are unavailable. In these instances, it is often possible to obtain this information directly from the manufacturer or supplier or from exemplar items. The investigator should, whenever possible, examine maintenance and cleaning instructions and records regarding equipment and appliances found in the area of origin. These records can prove helpful when a specific appliance or piece of equipment is being considered as an ignition source or fuel source.

Equipment and appliance operating procedures and cautions are also normally provided to the end user or consumer by the manufacturer or supplier. It may prove helpful to the investigator to obtain and review this type of information when accessing the condition of a specific piece of equipment or an appliance at the time of the fire.

8.4.1.2 Housekeeping. A lack of proper housekeeping measures can also contribute directly or indirectly to the occurrence of fire. Examples of such occurrences include careless use or disposal of smoking materials; refuse and other combustibles allowed to accumulate too close to an ignition source; quantities of dust or other combustible particulate matter becoming suspended in air (due to dust collection equipment needing to be cleaned or emptied) in the same environment as open flame- or spark-producing equipment; lint in dryers; and grease build-up in cooking areas.

8.4.1.3 Product Labels, Instructions, and Warnings. A lack of awareness of, or a disregard for warning labels and other safety instructions, can also result in the accidental ignition of a fire.

In many cases, the ignition factor of a fire is the result of the actions or omissions of the user of a product. The danger of improper actions or omissions may not always be obvious to a product user. Whenever a product has a hazard potential for supplying the ignition source, fuel, or oxygen portions of the ignition factor, it is incumbent upon the manufacturer and supplier to provide proper labeling, instructions, and warnings with their products. Likewise, it is incumbent upon the user to follow proper warnings and instructions.

8.4.1.4 Purpose of Labels. The purpose of labels is to provide the user with information about the product use at the closest possible point to its actual use. Labels can take several forms: printed labels attached to the product; labels printed on the packaging of the product; or molded, stamped, or engraved writing on the product or its container.

8.4.1.5 Purpose of Instructions. Instructions for a product are intended to inform the user on how the product is to be used safely, of the existence of any hazards, and how to minimize any risk to the user during the actual use of the product.

8.4.1.6 Purpose of Warnings. The overall purpose of a warning is to provide the user with information necessary to use a product safely or to make an informed decision not to use the product because of its hazard.

Warnings on the labels or instructions of a product should serve two objectives: to inform an unknowing user of the dangers posed by the use or misuse of the product, or to remind the user of the hazards of the product.

8.4.1.7 Key Elements of a Proper Warning. According to federal regulations, in order for warnings to be appropriate and effective, there are certain key elements that must be present:

- (1) An alert word
- (2) A statement of the danger
- (3) A statement of how to avoid the danger
- (4) Explanations of the consequences of the danger

Many of the standards that set elements of a proper warning are reflected in the following four elements.

(a) *Alert Word.* The alert word or signal word is the first sign to the user that there is a danger. "Caution," "Warning," or "Danger" are the most commonly used and approved alert words. Through its meaning, type style, type size, and contrast the alert word is designed to draw the user's attention to the warning that follows, and to give some concept of the degree of danger. Most standards hold that the alert words "Caution," "Warning," and "Danger" respectively signify increasing levels of hazard and risk.

ANSI Z535.4, *Product Safety Signs and Labels*, provides the following definitions:

CAUTION: Indicates a potentially hazardous situation that, if not avoided, may result in minor or moderate injury.

WARNING: Indicates a potentially hazardous situation that, if not avoided, could result in death or serious injury.

DANGER: Indicates an imminently hazardous situation that, if not avoided, will result in death or serious injury.

(b) *Statement of the Danger.* The statement of the danger must identify the nature and extent of the danger and the gravity of the risk of injury, for example: “Combustible,” “Flammable,” or “Extremely Flammable.” Risk is a function of the likelihood and severity of injury. Additional phrases such as “may explode,” or “can cause serious burns,” may also be necessary.

(c) *How to Avoid the Danger.* Warnings must provide potential users with information on how the hazard can be avoided and must tell them what to do or refrain from doing to remain safe when using the product.

(d) *Consequences of the Danger.* Warnings must also tell the user what would or could happen if the precautions listed are not followed.

8.4.1.8 Standards on Labels, Instructions and Warnings. Over the years government and industry have promulgated many standards, guidelines, and regulations dealing with safety warnings and safe product design.

Among the standards that deal with labels, instructions, and warnings are the following:

- (1) ANSI standards on labeling:
 - a. Z129.1, *Precautionary Labeling of Hazardous Industrial Chemicals*
 - b. Z400.1, *Material Safety Data Sheets — Preparation*
 - c. Z535.1, *Safety Color Code*
 - d. Z535.2, *Environmental and Facility Safety Signs*
 - e. Z535.3, *Criteria for Safety Symbols*
 - f. Z535.4, *Product Safety Signs and Labels*
 - g. Z535.5, *Accident Prevention Tags*
- (2) UL standard on labeling:
 - a. UL 969, *Standard for Marking and Labeling Systems*
- (3) Federal codes and regulations:
 - a. Consumer Safety Act (15 USC Sections 2051–2084, and 16 CFR 1000)
 - b. Hazardous Substances Act (15 USC Sections 1261 et seq., and 16 CFR 1500)
 - c. “Federal Hazards Communication Standard” (29 CFR 1910)
 - d. Flammable Fabrics Act (15 USC Sections 1191–1204 and 16 CFR 1615, 1616, 1630–1632)
 - e. Federal Food, Drug and Cosmetic Act (15 USC Section 321(m), and 21 CFR 600).
 - f. OSHA Regulations (29 CFR 1910)
- (4) Industry standard:
 - a. *FMC Product Safety Sign and Label System*

8.4.2 Recalls. Disregarding recall notices involving items that have the potential to become an ignition source can also result in a fire. Many times a recall notice is the result of reported fires, where a specific item has been identified as the ignition source.

8.4.3 Other Considerations. The differences between an individual’s lack of knowledge, carelessness, willful disregard, or negligence are often unclear to the investigator who reviews the circumstances and events leading up to a fire. A review of training records and interviews conducted with persons occupying

locations or spaces where a fire has occurred may provide the information needed to more clearly understand an individual’s level of involvement regarding the initiation of a fire.

8.4.4 Violations of Fire Safety Codes and Standards. Failure to adhere to pertinent, established fire safety codes and standards, industry standards, or good practices may result in fires or explosions. Noncompliance to these various safety prescriptions may be deliberate or unintentional.

8.5 Children and Fire. Playing with fire is an activity that a large number of children participate in for many reasons. The most common reason for children playing with fire is curiosity. To a young child, fire is intriguing, very powerful, and too often accessible. Firesetting may be a child’s means to express frustration or anger or to seek revenge or to call attention to himself or herself or to difficult circumstances.

Research has shown that the location where the fire is set and the motive for it often varies according to the age of the child. There are three recognized age groups.

8.5.1 Child firesetters (ages 2 to 6) are often responsible for fires in their homes or in the immediate area. Sometimes the fires are in areas that are hidden and out of sight of their guardian. These are usually curiosity firesetters.

8.5.2 Juvenile firesetters (ages 7 to 13) are often responsible for fires that start in their homes or in the immediate environment. They may also start fires in their educational setting. These firesetting events are usually associated with some broken family environment or physical or emotional trauma.

8.5.3 Adolescent firesetters (ages 14 to 16) are often responsible for fires that occur at places other than their homes. They target schools, churches, vacant buildings, fields, and vacant lots. These firesetters are often associated with a history of delinquency, disruptive rearing environment, poor social environment and emotional adjustments, peer pressure, and poor academic achievement. They sometimes work in pairs or small groups, with one individual dominant and others followers. These fires are often set to express their stress, anxiety, and anger, or as a symptom of another problem.

8.6 Incendiary Fires. Human factors involved in the setting of incendiary fires are closely related to motives examined in Section 19.4. The reader is referred that section for additional information.

8.7 Human Factors Related to Fire Spread. The spread of the fire can be affected significantly by the actions or omissions of the people present before or during the fire. These actions can act to accelerate or retard the spread of the fire. The investigator may need to evaluate these actions to determine the effects these actions had on the fire involved. Some of these actions include opening and closing doors or windows, fire fighting, operation of fire protection systems, and rescue. Some of these actions are addressed in 15.5.3 and 15.6.1.

Pre-fire conditions, such as housekeeping, functioning alarms, and compartmentation, may be documented after the fire by inspecting unburned areas of the building, prior fire department inspection records for nonresidential buildings, as well as by post-fire interviews. The investigator should not presume the conditions in the building prior to the fire.

8.8 Recognition and Response to Fires. In a fire, survivability of an individual is based on the ability of the individual to recognize and safely respond to the hazard in several ways. The individual must perceive the danger, the individual must make

a decision about some action to take, and the person must carry out that action. These three basic concepts will be addressed in this section.

8.8.1 Perception of the Danger (Sensory Cues). People become aware of the fire by any one or combination of several sensory cues.

- (a) *Sight.* Direct view of flames, smoke, visual alarms, or flicker
- (b) *Sound.* Crackling, failure of windows, audible alarms, dogs barking, children crying, voices, or shouts
- (c) *Feel.* Temperature rise or structural failure
- (d) *Smell.* Smoke odor

The sensory perception can be affected by factors such as whether the person is awake, asleep, or impaired. This impairment may be physical, mental, or effects of chemical agents (e.g., drugs, alcohol, carbon monoxide).

8.8.2 Decision to Act (Response). Once the danger has been perceived, a decision is made concerning how to respond. This decision is based on the severity of the danger perceived. The person's degree of impairment is a factor in the decision process.

8.8.3 Action Taken. The action taken by the individual can take any one or a combination of forms. These include the following:

- (1) Ignore the problem
- (2) Investigate
- (3) Fight the fire
- (4) Give alarm
- (5) Rescue or aid others
- (6) Re-enter after successful escape
- (7) Flee (escape)
- (8) Remain in place

8.8.4 Escape Factors. The success or failure of an attempt to escape a fire depends on a number of factors, including the following:

- (1) Identifiability of escape routes
- (2) Distance to a means of escape
- (3) Fire conditions such as the presence of smoke, heat, or flames
- (4) Presence of dead-end corridors
- (5) Path blocked by obstacles or people
- (6) Physical disabilities or impairments of occupants

8.8.5 Information Received from Survivors. Post-fire information obtained by interviewing witnesses (e.g., survivors, victims, occupants, passers-by, emergency responders) of a fire incident may be helpful in determining several factors. Such information may include the following:

- (1) Pre-fire conditions
- (2) Fire and smoke development
- (3) Fuel packages and their location and orientation
- (4) Victims' activities before, during, and after discovery of the fire
- (5) Actions taken by survivors resulting in their survival, that is, escape or take refuge
- (6) Decisions made by survivors and reasons for those decisions
- (7) Critical fire events such as flashover, structural failure, window breakage, alarm sounding, first observation of smoke, first observation of flame, fire department arrival, contact with others in the building

Chapter 9 Legal Considerations

9.1* Introduction. Legal considerations impact on every phase of a fire investigation. Whatever the capacity in which a fire investigator functions (public or private), it is important that the investigator be informed regarding all relevant legal restrictions, requirements, obligations, standards, and duties. Failure to do so could jeopardize the reliability of any investigation and could subject the investigator to civil liability or criminal prosecution.

It is the purpose of this chapter to alert the investigator to those areas that usually require legal advice, knowledge, or information. The legal considerations contained in this chapter and elsewhere in this guide pertain to the law in the United States. This chapter does not attempt to state the law as it is applied in each country or other jurisdiction. Such a task exceeds the scope of this guide. To the extent that statutes or case law are referred to, they are referred to by way of example only, and the user of this guide is reminded that "the law" is in a constant state of flux. Analogized to a living thing, both case law and statutory law are constantly subject to creation (by new enactment or decision), change (by modification or amendment), and death (by being repealed, overruled, or vacated). It is recommended that the investigator seek legal counsel to assist in understanding and complying with the legal requirements of any particular jurisdiction. Recognition of applicable legal requirements and considerations will help to ensure the reliability and admissibility of the investigator's records, data, and opinions.

9.2 Preliminary Legal Considerations.

9.2.1 Authority to Conduct the Investigation. The investigator should ascertain the basis and extent of his or her authority to conduct the investigation. Normally, the authority is public or governmental (i.e., police department, fire department, office of the fire marshal); contractual (e.g., insurance); or otherwise private (e.g., in the event of investigation conducted in anticipation of litigation). Proper identification of the basis of authority will assist the investigator in complying with applicable legal requirements and limitations.

The scope of authority granted to investigators from the public or governmental sector is usually specified within the codified laws of each jurisdiction, as supplemented by applicable local, agency, and department rules and regulations. Many states and local jurisdictions (i.e., cities, towns, or counties) have licensing or certification requirements for investigators. If such requirements are not followed, the results of the investigation may not be admissible and the investigator may face sanctions.

9.2.2 Right of Entry. The fact that an investigator has authority to conduct an investigation does not necessarily mean that he or she has the legal right to enter the property that was involved in the fire. Rights of entry are frequently enumerated by statutes, rules, and regulations. Illegal entry on the property could result in charges against the investigator (i.e., trespassing; breaking and entering; or obstructing, impeding, or hampering a criminal investigation).

Once a legal right of entry onto the property has been established, the investigator should notify the officer or authority in charge of the scene of his or her entry. An otherwise legal right of entry does not authorize entry onto a crime scene investigation. Further authorization by the specific agency or officer in charge is required. Once on the property,

extreme caution should be exercised to preserve the scene and protect the evidence.

Frequently, code provisions designed to protect public safety mandate that a building involved in a fire be demolished promptly to avoid danger to the public. This act can deny an investigator the only opportunity to examine the scene of a fire. When it is important to do so, court ordered relief prohibiting the demolition until some later and specified date may be obtained, most typically by way of injunction, to allow for the investigator's presence at the scene. This injunction may prove costly, however, as the party seeking the delay may be required to post a bond, procure guards, and secure the property during the intervening time period. Legal counsel should be able to anticipate needs in this regard and to respond to such needs promptly.

The investigator should remain aware that he or she may be required to produce evidence by order of court or pursuant to a subpoena. The investigator should exercise caution and not destroy, dispose of, or remove any evidence unless clearly and legally entitled to do so. Regarding investigations of major or catastrophic fires, courts are becoming increasingly more willing to enter orders designed to preserve the fire scene, thereby preserving the rights of all interested parties and entities to be aware of and examine all available evidence.

In the event that destruction, disposal, or removal is authorized or necessary, the investigator should engage in such acts only after the scene has been properly recorded and the record has been verified as to accuracy and completeness. Care should be taken to avoid spoliation.

9.2.3 Method of Entry. Whereas "right of entry" refers to the legal authority to be on a given premise or fire scene, this section concerns itself with how that authority is obtained. There are four general methods by which entry may be obtained: consent, exigent circumstance, administrative search warrant, and criminal search warrant.

9.2.3.1 Consent. The person in lawful control of the property can grant the investigator permission or consent to enter and remain on the property. This is a voluntary act on the part of the responsible person and can be withdrawn at any time by that person. When consent is granted, the investigator should document it. One effective method is to have the person in lawful control sign a written waiver.

9.2.3.2 Exigent Circumstance. It is generally recognized that the fire department has the legal authority to enter a property to control and extinguish a hostile fire. It also has been held that the fire department has an obligation to determine the origin and cause of the fire in the interest of the public good and general welfare.

The time period in which the investigation may continue or should conclude has been the subject of a Supreme Court decision (*Michigan v. Tyler*, 436 U.S. 499), when the Court held that the investigation may continue for a "reasonable period of time," which may depend on many variables. When the investigator is in doubt as to what is a "reasonable time," one of the other methods to secure or maintain entry should be considered.

9.2.3.3 Administrative Search Warrant. The purpose of an administrative search warrant is generally to allow those charged with the responsibility, by ordinance or statute, to investigate the origin and cause of a fire and to fulfill their obligation according to the law.

An administrative search warrant may be obtained from a court of competent jurisdiction upon a showing that consent has not been granted or has been denied. It is not issued on the traditional showing of "probable cause," as is the criminal search warrant, although it is still necessary to demonstrate that the search is reasonable. The search should be justified by a showing of reasonable governmental interest. If a valid public interest justifies the intrusion, then valid and reasonable probable cause has been demonstrated.

The scope of an administrative search warrant is limited to the investigation of the origin and cause of the fire. If during the search permitted by an administrative search warrant, evidence of a crime is discovered, the search should be stopped and a criminal search warrant should be obtained (*Michigan v. Clifford*, 464 U.S. 287).

9.2.3.4 Criminal Search Warrant. The purpose of a criminal search warrant is to allow the entry of government officials or agents to search for and collect any evidence of a crime. A criminal search warrant is obtained on the traditional showing of probable cause, in that the investigator is required to show that probable cause exists that a crime has been committed.

The investigator's application for obtaining a criminal search warrant typically includes the following:

- (1) Purpose and scope of the search
- (2) Location
- (3) Party against whom the search is directed
- (4) Time in which the search is to be initiated and concluded
- (5) Evidence that can be expected to be recovered

9.3 Evidence. Rules of evidence regulate the admissibility of proof at a trial. The purpose of rules of evidence is to ensure that the proof offered is reliable. A goal of every fire investigation is to produce *reliable* documents, samples, statements, information, data, and conclusions.

It is not necessary that every fire investigator become an expert on rules of evidence. If the practices and procedures recommended within this guide are complied with, the results of the investigation should be admissible.

9.3.1 Federal Rules of Evidence. Evidentiary requirements, standards, and rules vary greatly from jurisdiction to jurisdiction. For this reason, those rules of evidence that are in effect in individual states, territories, provinces, and international jurisdictions should be consulted. The United States Federal Rules of Evidence have been relied on throughout this guide for guidance in promoting their general criteria of relevance and identification.

The Federal Rules of Evidence became effective on July 1, 1975. The federal rules are applicable in all civil and criminal cases in all United States courts of appeal, district courts, courts of claims, and before United States magistrates. The federal rules are recognized as having essentially codified the well-established rules of evidence, and many states have adopted, in whole or in part, the federal rules.

9.3.2 Types of Evidence. There are basically three types of evidence, all of which in some manner relate to fire investigations. They are demonstrative evidence, documentary evidence, and testimonial evidence. They are described in detail in 9.3.2.1, 9.3.2.2, and 9.3.2.3.

9.3.2.1 Demonstrative Evidence. This is a type of evidence that consists of tangible items as distinguished from testimony of witnesses about the items. It is evidence from which one can derive a relevant firsthand impression by seeing, touching, smelling, or hearing the evidence.

Demonstrative evidence should be authenticated. Evidence is authenticated in one of two ways: through witness identification (i.e., recognition testimony) or by establishing a chain of custody (an unbroken chain of possession from the taking of the item from the fire scene to the exhibiting of the item).

9.3.2.1.1 Photographs/Illustrative Forms of Evidence. Among the most frequently utilized types of illustrative demonstrative evidence are maps, sketches, diagrams, and models. They are generally admissible on the basis of testimony that they are substantially accurate representations of what the witness is endeavoring to describe.

Photographs and movies are viewed as a graphic portrayal of oral testimony and become admissible when a witness has testified that they are correct and accurate representations of relevant facts personally observed by the witness. The witness often need not be the photographer but should know about the facts represented or the scene or objects photographed. Once this knowledge is shown, the witness can state whether a photograph correctly and accurately portrays those facts.

9.3.2.1.2 Samples. Chain of custody is especially important regarding samples. To ensure admissibility of a sample an unbroken chain of possession should be established.

9.3.2.2 Documentary Evidence. Documentary evidence is any evidence in written form. It may include business records such as sales receipts, inventory lists, invoices, bank records, including checks and deposit slips; insurance policies; personal items such as diaries, calendars, telephone records; fire department records such as the fire investigator's report, the investigator's notes, the fire incident report, witness statement reduced to writing; or any law enforcement agency reports, including investigation reports, police officer operational reports, fire or police department dispatcher logs; division of motor vehicle records; written transcripts of audio- or videotape recordings. Any information in a written form related to the fire or explosion incident is considered documentary evidence. Documentary evidence is generally admissible if the documents are maintained in the normal course of business.

All witness statements should be properly signed by the witness, dated, and witnessed by a third party when possible. It is important to obtain the full name, address, and telephone number of the witness. Any additional identifying information (e.g., date of birth, social security number, and automobile license number) may prove helpful in the event that difficulties are later encountered in locating the witness. Statements actually written by the witness may be required in certain jurisdictions.

9.3.2.3 Testimonial Evidence. Testimonial evidence is that given by a competent live witness speaking under oath or affirmation. Investigators are frequently called on to give testimonial evidence regarding the nature, scope, conduct, and results of their investigation. It is incumbent on all witnesses to respond completely and honestly to all questions.

9.3.3 Post-fire Interviews and Witness Statements. Post-fire interviews of witnesses and the taking of witness statements are an important aspect of the fire investigation process. For specific procedures and techniques to be utilized when conducting interviews, see Section 11.3.

9.3.4 Constitutional Considerations. Within the United States and its territories, investigators should be aware of the constitutional safeguards that are generally applicable to any witness when the interview is conducted by a representative, employee,

or agent of any governmental entity. This includes members of public fire services and generally extends to most investigators functioning in a public capacity.

Within the United States and its territories, witnesses being interviewed have constitutional guarantees under the Fifth and Sixth Amendments. These guarantees include the right to have an attorney present during questioning. Questions regarding personal identification are not subject to constitutional protection.

In light of the numerous criminal charges that can be made as a result of a fire, each investigator should ascertain whether he or she is required to give warning under the Miranda Rule and, if so, when to give it and how to give it.

The Miranda Rule requires that, prior to any custodial interrogation, the person/witness should be warned of the following:

- (1) That they have a right to remain silent
- (2) That any statement they do make may be used as evidence against them
- (3) That they have the right to the presence of an attorney
- (4) That, if they cannot afford an attorney, one will be appointed for them prior to any questioning if they so desire

Unless and until these warnings or a waiver of these rights are demonstrated at trial, no evidence obtained in the interrogation may be used against the accused (formerly the witness) (*Miranda v. Arizona*, 384 U.S. 436).

Witnesses interviewed in "custodial settings" should be advised of their constitutional rights. Though interviews conducted on a fire scene are not generally considered to be custodial, depending on the circumstances, they may be custodial. The custodial setting depends on many variables, including the location of the interview, the length of the interview, who is present and who participates, and the witness's perception of whether he or she will be restrained if he or she attempts to leave. If there is any doubt in the mind of the investigator as to whether the witness is being questioned in a custodial setting, the witness should be advised of his or her constitutional rights. It is recommended that, when a witness is advised of his or her constitutional rights, as required by the Miranda Rule, they be on a written form that can be signed by the witness.

9.3.5 Burden of Proof. The burdens of proof in civil cases differ from those in criminal cases.

In a criminal case, because the civil liberties of the defendant are at stake, the prosecutor must prove the defendant's guilt beyond a reasonable doubt.

Civil cases typically involve disputes over money. In most civil cases, the plaintiff must prove his claims by a preponderance of the evidence, which means, "more likely than not."

9.3.6 Spoliation of Evidence.

9.3.6.1 Spoliation of evidence refers to the loss, destruction, or material alteration of an object or document that is evidence or potential evidence in a legal proceeding by one who has the responsibility for its preservation. Spoliation of evidence may occur when the movement, change, or destruction of evidence, or the alteration of the scene significantly impairs the opportunity of other interested parties to obtain the same evidentiary value from the evidence, as did any prior investigator.

9.3.6.2 The responsibility of the investigator (or anyone who handles or examines evidence) for evidence preservation, and the scope of that responsibility varies based on such factors as

the jurisdiction, whether the investigator is a public official or private sector investigator, whether criminal conduct is indicated, and applicable laws and regulations.

9.3.6.3 Efforts to photograph, document, or preserve evidence should apply not only to evidence relevant to an investigator's opinions, but also to evidence of reasonable alternate hypotheses that were considered and ruled out.

9.3.6.4 Criminal and civil courts have applied various remedies when there has been spoliation of evidence. Remedies employed by the courts may include discovery sanctions, monetary sanctions, application of evidentiary inferences, limitations under the rules of evidence, exclusion of expert testimony, dismissal of a claim or defense, independent tort actions for the intentional or negligent destruction of evidence, and even prosecution under criminal statutes relating to obstruction of justice. Investigators should conduct their investigations so as to minimize the loss or destruction of evidence and thereby to minimize allegations of spoliation.

9.3.6.5 If the investigator determines that significant alteration of the fire scene will be necessary to complete the fire investigation, special care should be taken to photograph and document the scene and preserve relevant evidence. Public sector investigators may have different notification responsibilities than the private sector investigator. Responsibility for notification varies based on jurisdictions, scope, procedures, and the circumstances of the fire. Interested parties should make public officials aware of their interest.

9.3.6.6 Fire investigation usually requires the movement of evidence or alteration of the scene. In and of itself, such movement of evidence or alteration of the scene should not be considered spoliation of evidence. Physical evidence may need to be moved prior to the discovery of the cause of the fire. Additionally, it is recognized that it is sometimes necessary to remove the potential causative agent from the scene and even to carry out some disassembly in order to determine whether the object did, in fact, cause the fire, and which parties may have contributed to that cause. For example, the manufacturer of an appliance may not be known until after the unit has been examined for identification. Such activities should not be considered spoliation.

Still another consideration is protection of the evidence. There may be cases where it is necessary to remove relevant evidence from a scene in order to ensure that it is protected from further damage or theft. Steps taken to protect evidence should also not be considered spoliation.

9.3.6.7 Once evidence has been removed from the scene, it should be maintained and not be destroyed or altered until others who have a reasonable interest in the matter have been notified. Any destructive testing or destructive examination of the evidence that may be necessary should occur only after all reasonably known parties have been notified in advance and given the opportunity to participate in or observe the testing. Guidance regarding notification can be found in ASTM E 860, *Standard Practice for Examining and Testing Items That Are or May Become Involved in Products Liability Litigation*, and ASTM E 1188, *Standard Practice for Collection and Preservation of Information and Physical Items by a Technical Investigator*. Guidance for disposal of evidence may be found in Section 14.11 of this guide. Guidance for labeling of evidence can be found in ASTM E 1459, *Standard Guide for Physical Evidence Labeling and Related Documentation*.

9.4 Criminal Prosecution. Though there are certain fire-related crimes that appear to exist in all jurisdictions (e.g., arson), the full scope of possible criminal charges is as varied as the jurisdictions themselves, their resources, histories, interests, and concerns.

9.4.1 Arson. Arson is the most commonly recognized fire-related crime. *Black's Law Dictionary*, 6th edition, 1990, defines arson as follows:

Arson. At common law, the malicious burning of the house of another. This definition, however, has been broadened by state statutes and criminal codes. For example, the Model Penal Code, Section 220.1 (1), provides that a person is guilty of arson, a felony of the second degree, if he starts a fire or causes an explosion with the purpose of: (a) destroying a building or occupied structure of another; or (b) destroying or damaging any property, whether his own or another's, to collect insurance for such a loss.

In several states, this crime is divided into arson in the first, second, and third degrees: the first degree including the burning of an inhabited dwelling-house in the nighttime; the second degree, the burning (at night) of a building other than a dwelling-house, but so situated with reference to a dwelling-house as to endanger it; the third degree, the burning of any building or structure not the subject of arson in the first or second degree, or the burning of property, his own or another's with intent to defraud or prejudice the insurer thereof.

9.4.1.1 Arson Statutes. The laws of each jurisdiction should be carefully researched regarding the requirements, burden of proof, and penalties for the crime of arson. Arson generally, or in the first and second degrees (if so classified), is deemed a felony offense. Such felony offenses require proof that the person intentionally damaged property by starting or maintaining a fire or causing an explosion. Arson in the third degree (if so classified) generally requires only reckless conduct that results in the damage of property and is often a misdemeanor offense.

9.4.1.2 Factors to Be Considered. The following factors are of relevance to most investigations when there is a possibility that the criminal act of arson was committed:

- (1) Was the building, starting, or maintaining of a fire or the causing of an explosion intentional?
- (2) Was another person present in or on the property?
- (3) Who owned the property?
- (4) If the property involved was a building, what type of building and what type of occupancy was involved in the fire?
- (5) Did the perpetrator act recklessly, though aware of the risk present?
- (6) Was there actual presence of flame?
- (7) Was actual damage to the property or bodily injury to a person caused by the fire or explosion?

9.4.2 Other Fire-Related Criminal Acts. The bases of fire-related criminal prosecution vary greatly from jurisdiction to jurisdiction. It is impossible to list all possible offenses. The following nonexclusive list of sample acts that can result in criminal prosecution will alert the investigator to the possibilities in any given jurisdiction: insurance fraud; leaving fires unattended; allowing fires to burn uncontrolled; allowing fires to escape; burning without proper permits; reckless burning; negligent burning; reckless endangerment; criminal mischief; threatening

a fire or bombing; failure to report a fire; failure to report smoldering conditions; tampering with machinery, equipment, or warning signs used for fire detection, prevention, or suppression; failure to assist in suppression or control of a fire; sale or installation of illegal or inoperative fire suppression or detection devices; and use of certain equipment or machinery without proper safety devices, without the presence of fire extinguishers, or without other precautions to prevent fires.

Criminal sanctions are almost universally imposed for failures to obey orders of fire marshals, fire wardens, and other officials and agents of public sector entities created to promote, accomplish, or otherwise ensure fire prevention, protection, suppression, or safety.

Key industries or resources within a given jurisdiction often result in the enactment of special and detailed criminal provisions. By way of example, criminal statutes exist with specific reference to fires in coal mines, woods, prairie lands, forests, and parks, and during drought or emergency conditions. Special provisions also exist regarding the type of occupancy or use of a given structure (i.e., penal/correctional institutions, hospitals, nursing homes, day-care or child-care centers, and schools). The use or transporting of hazardous or explosive materials is regulated in nearly all jurisdictions.

9.5 Arson-Reporting Statutes. Many jurisdictions have enacted statutes requiring that information be released to public officials regarding fires that may have been the result of a criminal act.

Commonly referred to as the “arson immunity acts,” the arson-reporting statutes generally provide that an insurance company should, on written request from a designated public entity or official, release enumerated items of information and documentation regarding any loss or potential loss due to a fire of “suspicious” or incendiary origin. The information is held in confidence until its use is required in a civil or criminal proceeding. The insurance company is held immune from civil liability and criminal prosecution, premised upon its release of the information, pursuant to the statute.

The number of jurisdictions with an arson-reporting act is growing, and it is anticipated that they will continue to grow. As enacted in each jurisdiction, the acts vary greatly as to both requirements and criminal sanctions. Each act does impose criminal sanctions for failure to comply.

In order to avoid criminal prosecution, the insurance companies and investigators operating on its behalf should be aware of any applicable arson-reporting act. One should be alert to the following variations that currently exist.

(a) In addition to the insurance company, some jurisdictions require compliance by its employees, agents, investigators, insureds, and attorneys.

(b) In addition to response to specific written requests for information or documentation, some jurisdictions state that an insurance company *may* inform the proper authorities whenever it suspects a fire was of “suspicious origin.” Other jurisdictions state that an insurance company must inform the proper authorities whenever it suspects a fire was of “suspicious origin.”

Note that the term *suspicious origin*, as used within this section, refers to the actual language of some arson-reporting statutes. This guide does not recognize mere suspicion as an accurate or acceptable level of proof for making determinations of origin or cause, nor does it recognize “suspicious origin” as an accurate or acceptable description of cause or origin. This guide discourages the use of such terms.

(c) In addition to requiring production of specifically enumerated items of information and documentation, some jurisdictions require production of all information and documentation.

(d) Though most jurisdictions ensure absolute confidentiality of the information and documentation released, pending its use at a criminal or civil proceeding, other jurisdictions allow its release to other interested public entities and officials.

(e) In many jurisdictions, the immunity from civil liability and criminal prosecution is lost in the event that information was released maliciously or in bad faith.

9.6 Civil Litigation. Many fires result in civil litigation. These lawsuits typically involve claims of damages for death, injury, property damage, and financial loss caused by a fire or explosion. The majority of civil lawsuits are premised on allegations of negligence. A significant number of civil lawsuits are premised on the legal principle of product liability or alleged violations of applicable codes and standards.

9.6.1 Negligence. Negligence generally applies to situations in which a person has not behaved in the manner of a reasonably prudent person in the same or similar circumstances. Liability for negligence requires more than conduct. The elements that traditionally should be established to impose legal liability for negligence may be stated briefly as follows.

(a) *Duty.* A duty requiring a person to conform to a certain standard of conduct, for the protection of others against unreasonable risks

(b) *Failure.* A failure by the person to conform to the standard required

(c) *Cause.* A reasonably close causal connection between the conduct of the person and resulting injury to another (generally referred to as “legal cause” or “proximate cause”)

(d) *Loss.* Actual loss or damage resulting to the interests of another

A hypothetical example of the application of the elements of negligence follows.

The operator of a nursing home has a *duty* to install operable smoke detectors within the nursing home for the protection of the inhabitants of the nursing home. A reasonably prudent nursing home operator would have installed the smoke detectors. The operator of the nursing home *failed* to install operable smoke detectors. A fire began in a storage room. Because there were no smoke detectors, the staff and occupants of the nursing home were not alerted to the presence of the fire in time to allow the occupants to reach safety, and an occupant who could have otherwise been saved died as a result of the fire. The death of the occupant was *proximately caused* by the failure to install operable smoke detectors. The death constitutes actual *loss* or *damage* to the deceased occupant and his or her family. Once all four elements are established, liability for negligence may be imposed.

9.6.2 Codes, Regulations, and Standards. Various codes, regulations, and standards have evolved through the years to protect lives and property from fire. Violations of codes, regulations, rules, orders, or standards can establish a basis of civil liability in fire or explosion cases. Further, many jurisdictions have legislatively determined that such violations either establish negligence or raise a presumption of negligence. By

statute, violation of criminal or penal code provisions may also entitle the injured party to double or triple damages.

9.6.3 Product Liability. Product liability refers to the legal liability of manufacturers and sellers to compensate buyers, users, and even bystanders for damages or injuries suffered because of defects in goods purchased. This tort makes manufacturers liable if their product has a defective condition that makes it unreasonably dangerous (unsafe) to the user or consumer.

Although the ultimate responsibility for injury or damage most frequently rests with the manufacturer, liability may also be imposed upon a retailer, occasionally on a wholesaler or middleman, on a bailor or lessor, and infrequently on a party wholly outside the manufacturing and distributing process, such as a certifier. This ultimate responsibility may be imposed by an action by the plaintiff against the manufacturer directly, or by way of claims for indemnification or contribution against others who might be held liable for the injury caused by the defective product. (*See Black's Law Dictionary, 6th ed., p. 1209.*)

9.6.4 Strict Liability. Courts apply the concept of strict liability in product liability cases in which a seller is liable for any and all defective or hazardous products that unduly threaten a consumer's personal safety. This concept applies to all members involved in the manufacturing and selling of any facet of the product.

The concept of strict liability in tort is founded on the premise that when a manufacturer presents a product or good to the public for sale, the manufacturer represents that the product or good is suitable for its intended use.

In order to recover in strict liability, it is essential to prove that the product was defective when placed in the stream of commerce and was, therefore, unreasonably dangerous.

The following types of defects have been recognized: design defects; manufacturing defects; failure to warn or inadequacy of warning; and failure to comply with applicable standards, codes, rules, or regulations. The three most commonly applied defects are described as follows.

(a) *Design Defect.* The basic design of the product contains a fault or flaw that has made the product unreasonably dangerous.

(b) *Manufacturing Defect.* The design of the product may have been adequate, but a fault or mistake in the manufacturing or assembly of the product has made it unsafe.

(c) *Inadequate Warnings.* The consumer was not properly instructed in the proper or safe use of the product; nor was the consumer warned of any inherent danger in the possession of, or any reasonably foreseeable use or misuse of, the product.

Strict liability applies, although the seller has exercised all possible care in the preparation and sale of a product. It is not required that negligence be established. (*See Restatement of the Law, Second, Torts, Section 402A.*)

9.7 Expert Testimony.

9.7.1 General Witness. An investigator will often be called to give testimony before courts, administrative bodies, regulatory agencies, and related entities. In addition to giving factual testimony, an investigator may be called to give conclusions or opinions regarding a fire.

9.7.2 Litigation or Expert Witness. For purposes of litigation, only expert witnesses are allowed to offer opinion testimony at the discretion of the court. An expert witness is generally defined as someone with sufficient skill, knowledge, or experience in a given field so as to be capable of drawing inferences or reaching conclusions or opinions that an average person

would not be competent to reach. The expert's opinion testimony should aid the judge or jury in their understanding of the fact at issue and thereby aid in the search for truth.

The opinion or conclusion of the investigator testifying as an expert witness is of no greater value in ascertaining the truth of a matter than that warranted by the soundness of the investigator's underlying reasons and facts. The evidence that forms the basis of any opinion or conclusion should be relevant and reliable and, therefore, admissible. The proper conduct of an investigation will ensure that these indices of reliability and credibility are met.

Chapter 10 Safety

10.1* General. Fire scenes by their nature are dangerous places. Fire investigators have a duty to themselves and to others who may be endangered at fire scenes to exercise due caution during their investigations. This chapter will provide the investigator with some basic recommendations concerning a variety of safety issues, including personal protective equipment (PPE). It should be noted, however, that the investigator should be aware of and follow the requirements of safety-related laws or those policies and procedures established by their agency, company, or organization.

10.1.1 Investigating the Scene Alone. Fire scene examinations should not be undertaken alone. A minimum of two individuals should be present to ensure that assistance is at hand if an investigator should become trapped or injured. If it is impossible for the investigator to be accompanied, he or she should, at the least, notify a responsible person of where the investigator will be and of when he or she can reasonably be expected to return.

10.1.2 Safety Clothing and Equipment. Proper safety equipment, including safety shoes or boots, gloves, safety helmet, and protective clothing, should be worn at all times while investigating the scene. The type of protective clothing will depend on the type and level of hazard present. When there is a potential for injuries from falling objects or potential cuts or scrapes from sharp objects, fire-fighting turnout gear or similar clothing that provides this type of protection may be the best choice. When an investigator is dealing with a potential exposure of toxic substances and debris, disposable coveralls as required by some safety-related regulations may be necessary. In high hazard atmospheres *hazardous environmental suits* may be required. Whenever PPE is worn to provide protection from a hazardous environment, it should be properly decontaminated or disposed of in order to avoid subsequent exposure to residues. Even when choosing to wear standard cloth coveralls or fire-fighting turnout gear, consideration should be given to the safe handling of the clothing so as not to create additional exposure.

Appropriate filter or self-contained breathing apparatus (SCBA) could be necessary at some fire scenes. Immediately following fire extinguishment, there may be combustion gases and smoke, low oxygen concentration, toxic or carcinogenic airborne particles, and high heat conditions present. In these atmospheres, the investigator should utilize SCBA and other PPE that is appropriate. The act of disturbing the fire debris may create dust, which should be considered hazardous, and the investigator should consider wearing a filter mask with the appropriate cartridge. The decision to wear a full face mask versus a half face mask respirator will be up to the wearer and the hazards present. In the respirator selection process, consideration should be given to eye protection, as many toxic

substances can be absorbed through the sclera. If a half face respirator is selected, then the wearing of a pair of unvented goggles will provide protection from this type of hazard.

The proper selection of gloves should also be considered. If fire-fighting gloves or lighter leather gloves are selected, then protection from the leaching of toxic substances should be provided. In many instances, wearing latex (or similar) gloves underneath the leather gloves may provide the protection needed, or the investigator may need to select gloves that would be more appropriate for the hazard present.

Certain other equipment might also be necessary to maintain safety. This equipment includes flashlights or portable lighting, fall protection equipment, environmental monitoring and sampling equipment, and other specialized tools and equipment. Some of this equipment requires special training in its use.

10.1.3 Fire Scene Hazards. The investigator should remain aware of the general and particular dangers of the scene under investigation. The investigator should keep in mind the potential for serious injury at any time and should not become complacent or take unnecessary risks. The need for this awareness is especially important when the structural stability of the scene is unknown or when the investigation requires that the investigator be working above or below ground level.

10.1.4 Personal Health and Safety. The investigator should be cognizant of factors associated with chemical, biological, radiological, or other potential hazards that may threaten personal health and safety while conducting fire scene examinations. Where these conditions exist, special precautions should be taken, as mentioned in 10.1.2.

Industries are becoming more cognizant of these hazards. Proper identification or labeling may have been destroyed as a result of the fire. The fire investigator should seek out knowledgeable persons from the facility to identify any possible substances that may endanger those working in and around the fire scene. The facility should have material safety data sheets (MSDS), safety plans, and standard operating procedures (SOPs) that reference their hazardous commodities and that will also be beneficial to the investigator.

Of further concern is the use of hazardous substances as a form of terrorism. Whenever there is suspicion that the scene may be a crime scene as a result of a terrorist act, all precautions should be implemented.

10.1.5 Investigator Fatigue. It is common for investigators to put in long periods of strenuous personal labor during an incident scene investigation. This may result in fatigue, which can adversely influence an investigator's physical coordination, strength, or judgment to recognize or respond to hazardous conditions or situations. Keep in mind that the use of heavy safety clothing and respiratory protection will further increase fatigue.

Periodic rest, fluid replacement, and nourishment should be provided in a safe atmosphere, remote but convenient to the fire scene. This precaution is particularly necessary on large or major incident scenes.

10.2 Factors Influencing Scene Safety. Many varying factors can influence the danger potential of a fire or explosion scene. The investigator should be constantly on the alert for these conditions and should ensure that appropriate safety precautions are taken by all persons working at the scene.

10.2.1 Status of Suppression. If the investigator is going to enter parts of the structure before the fire is completely extinguished, he or she should receive permission from the fire

ground commander. The investigator should coordinate his or her activities with the fire suppression personnel and keep the fire ground commander advised of the areas into which he or she will be entering and working. The investigator should not move into other areas of the structure without informing the fire ground commander. The investigator should not enter a burning structure unless accompanied by fire suppression personnel, and unless appropriately trained to do so.

When conducting an investigation in a structure soon after the fire is believed to be extinguished, the investigator should be mindful of the possibility of a rekindle. The investigator should be alert for continued burning or a rekindle and should remain aware at all times of the fastest or safest means of egress.

10.2.2 Structural Stability. By their nature, most structures that have been involved in fires or explosions are structurally weakened. Roofs, ceilings, partitions, load-bearing walls, and floors may have been compromised by the fire or explosion.

The investigator's task requires that he or she enter these structures and often requires that he or she perform tasks of debris removal that may dislodge or further weaken these already unsound structures. Before entering such structures or beginning debris removal, the investigator should make a careful assessment of the stability and safety of the structure. If necessary, the investigator should seek the help of qualified structural experts to assess the need for the removal of dangerously weakened construction or should make provisions for shoring up load-bearing walls, floors, ceilings, or roofs.

The investigator should also be especially mindful of hidden holes in floors or of other dangers that may be hidden by standing water or loosely stacked debris. The investigator should keep in mind that the presence of pooled extinguishment water or of weather-related factors — such as the weight of rain water, high winds, snow, and ice — can affect the ability of structures to remain sound. For example, a badly damaged structure may only continue to stand until the ice melts.

10.2.3 Utilities. The investigator should determine the status of all utilities (i.e., electric, gas, and water) within the structure under investigation. Determine before entering if electric lines are energized (primary, secondary, or temporary electrical service), if fuel gas lines are charged, or if water mains and lines are operative. Determining the status of all utilities is necessary to prevent the possibility of electrical shock or inadvertent release of fuel gases or water during the course of the investigation.

10.2.4 Electrical Hazards. Although the fire investigators may arrive on the scene hours or even days later, they should recognize potential hazards in order to avoid injury or even death. Serious injury or death can result from electric shocks or burns. Investigators as well as fire officers should learn to protect themselves from the dangers of electricity while conducting fire scene examinations. The risk is particularly high during an examination of the scene immediately following the fire. When conditions warrant, the investigator should ensure that the power to the building or to the area affected has been disconnected. The fire investigator should not disconnect the building's electric power but should ensure that the authorized utility does so.

When electrical service has been interrupted and the power supply has been disconnected, a tag or lock should be attached to the meter, indicating that power has been shut off. In considering potential electrical hazards, always assume that danger is present. The investigator should personally verify

that the power has been disconnected. This verification can be accomplished with the use of a voltmeter. Some meters allow the accurate measuring of volts, ohms, and resistance. Other devices are designed simply to indicate the presence of alternating current. These pencil-sized products give an audible or visual alarm when the device tip is placed on the wire (bare or jacketed). If any doubt exists as to whether the equipment is energized, call the local electric utility for verification.

The investigator may be working at fire scenes that have been equipped with temporary wiring. The investigator should be aware that temporary wiring for lighting or power arrangements is often not properly installed, grounded, or insulated and, therefore, may be unsafe.

The investigator should consider the following electrical hazards when examining the fire scene.

- (a) Consider all wires energized or “hot,” even when the meter has been removed or disconnected.
- (b) When approaching a fire scene, be alert to fallen electrical wires on the street; on the ground; or in contact with a metal fence, guard rail, or other conductive material, including water.
- (c) Look out for antennas that have fallen on existing power lines, for metal siding that has become energized, and for underground wiring.
- (d) Use caution when using or operating ladders or when elevating equipment in the vicinity of overhead electric lines.
- (e) Note that building services are capable of delivering high amperage and that short circuiting can result in an intense electrical flash, with the possibility of serious physical injury and burns.
- (f) Rubber footwear should not be depended on as an insulator.
- (g) A flooded basement should not be entered if the electrical system is energized. Energized electrical equipment should not be turned off manually while standing in water.
- (h) Avoid operating any electrical switch or non-explosion-proof equipment in the area that might cause an explosion if flammable gas or vapors are suspected of being present. (See 10.2.7.) When electric power must be shut off, it should be done at a point remote from the explosive atmosphere.
- (i) Establish lines of communication and close cooperation with the utility company. Power company personnel possess the expertise and equipment necessary to deal with electrical emergencies.
- (j) Locate and avoid underground electric supply cables before digging or excavating on the fire scene.
- (k) Be aware of multiple electrical services that may not be disconnected, extension cords from neighboring buildings, and similar installations.
- (l) Always use a meter to determine whether the electricity is off.

10.2.5 Standing Water. Standing water can pose a variety of dangers to the investigator. Puddles of water in the presence of energized electrical systems can be lethal if the investigator should touch an energized wire while standing in a puddle.

Pools of water that may appear to be only inches deep may in fact be well over the investigator’s head. Pools of water may also conceal hidden danger such as holes or dangerous objects that may trip or otherwise injure the investigator.

10.2.6 Safety of Bystanders. Fire and explosion scenes always generate the interest of bystanders. Their safety, as well as the security of the scene and its evidence, should be addressed by the investigator.

The investigation scene should be secured from entry by curious bystanders. This may be accomplished by merely roping off the area and posting “Keep Out” signs and barricade tape, or it may require the assistance of police officers, fire service personnel, or other persons serving as guards. Any unauthorized individuals found within the fire investigation scene area should be identified, their identity noted, and then they should be required to leave.

10.2.7 Safety of the Fire Scene Atmosphere. Fires and explosions often generate toxic or noxious gases. The presence of hazardous materials in the structure is certain. Homes contain chemicals in the kitchen, bath, and garage that can create great risk to the investigator if he or she is exposed to them. Commercial and business structures are generally more organized in the storage of hazardous materials, but the investigator cannot assume that the risk is less in such structures. Many buildings older than 20 years will contain asbestos. The investigator should be aware of the possibility that he or she could become exposed to dangerous atmospheres during the course of an investigation.

In addition, it is not uncommon for atmospheres with insufficient oxygen to be present within a structure that has been exposed to fire or explosion. Fire scene atmospheres may contain ignitable gas, vapors, and liquids. The atmosphere should be tested using appropriate equipment to determine whether such hazards or conditions exist before working in or introducing ignition sources into the area. Such ignition sources may include electrical arcs from flashlights, radios, cameras and their flashes, and smoking materials.

10.3 Criminal Acts or Acts of Terrorism. Fire is an event that can result from a criminal act. The initial incendiary device that created the fire or explosion may not be the only device left at the scene by the perpetrator. A secondary incendiary or explosive device may be left at the scene with the intent to harm fire, rescue, or investigative personnel. Of further concern are the chemicals used in the device that may leave a residue, creating an additional exposure.

10.3.1 Secondary Devices. The potential endangerment from a secondary incendiary or explosive device is remote compared to other hazards created at the scene from the initial device. However, the investigator should always be wary of any unusual packages or containers at the crime scene. If there is reason to believe that such a device may exist, it is necessary to contact the appropriate authorities to have specialists “sweep” the area. Close cooperation between investigative personnel and the explosive ordnance disposal (EOD) specialists can preclude the unnecessary destruction of the crime scene.

10.3.2 Residue Chemicals. If the incendiary or explosive device is rendered safe by the appropriate personnel, care should be taken when handling the rendered device or any residue from the device. Exposure to the chemical residue could endanger the investigator. Appropriate protective clothing and breathing apparatus should be worn while in the process of collecting such evidence.

10.3.3 Biological and Radiological Terrorism. There is a potential for a terrorist to release biological or radiological particulates as a part of his or her terrorist act. Usually the emergency response personnel will be aware of such an act while mitigating

the emergency incident. If there is any suspicion that either type of hazardous substance has been released, the scene must be rendered safe prior to the entry of investigative personnel. If this is not possible and the investigation is to go forward, only those investigative personnel trained to work in such atmospheres should be allowed to enter the scene.

10.3.4 Exposure to Tools and Equipment. Many of the tools and equipment used in the process of conducting an investigation may be rendered unsafe after being used in hazardous atmospheres. The necessary procedures, equipment, tools, and supplies to render your equipment safe should be in place prior to undertaking the investigation. Precautions should also be in place to dispose of the tools safely should they be incapable of being rendered safe.

Chapter 11 Sources of Information

11.1* General.

11.1.1 Purpose of Obtaining Information. The thorough fire investigation always involves the examination of the fire scene, either by visiting the actual scene or by evaluating the prior documentation of that scene.

By necessity, the thorough fire investigation also encompasses interviewing and the research and analysis of other sources of information. These activities are not a substitute for the fire scene examination. They are a complement to it.

Examining the fire scene, interviewing, and conducting research and analysis of other sources of information all provide the fire investigator with an opportunity to establish the origin, cause, and responsibility for a particular fire.

11.1.2 Reliability of Information Obtained. Generally, any information solicited or received by the fire investigator during a fire investigation is only as reliable as the source of that information. As such, it is essential that the fire investigator evaluate the accuracy of the information's source. Certainly, no information should be considered to be accurate or reliable without such an evaluation of its source.

This evaluation may be based on many varying factors depending on the type and form of information. These factors may include the fire investigator's common sense, the fire investigator's personal knowledge and experience, the information source's reputation, or the source's particular interest in the results of the fire investigation.

11.2 Legal Considerations.

11.2.1 Freedom of Information Act. The Freedom of Information Act provides for making information held by federal agencies available to the public unless it is specifically exempted from such disclosure by law. Most agencies of the federal government have implemented procedures designed to comply with the provisions of the act. These procedures inform the public where specific sources of information are available and what appeal rights are available to the public if requested information is not disclosed.

Like the federal government, most states have also enacted similar laws that provide the public with the opportunity to access sources of information concerning government operations and their work products. The fire investigator is cautioned, however, that the provisions of such state laws may vary greatly from state to state.

11.2.2 Privileged Communications. Privileged communications are those statements made by certain persons within a protected relationship such as husband-wife, attorney-client, priest-penitent, and the like. Such communications are protected by law from forced disclosure on the witness stand at the option of the witness spouse, client, or penitent.

Privileged communications are generally defined by state law. As such, the fire investigator is cautioned that the provisions of such laws may vary greatly from state to state.

11.2.3 Confidential Communications. Closely related to privileged communications, confidential communications are those statements made under circumstances showing that the speaker intended the statements only for the ears of the person addressed.

11.3 Forms of Information. Sources of information will present themselves in differing forms. Generally, information is available to the fire investigator in four forms: verbal, written, visual, and electronic.

11.3.1 Verbal Information. Verbal sources of information, by definition, are limited to the spoken word. Such sources, which may be encountered by the fire investigator, may include, but are not limited to, verbal statements during interviews, telephone conversations, tape recordings, radio transmissions, commercial radio broadcasts, and the like.

11.3.2 Written Information. Written sources of information are likely to be encountered by the fire investigator during all stages of an investigation. Such sources may include, but are not limited to, written reports, written documents, reference materials, newspapers, and the like.

11.3.3 Visual Information. Visual sources of information, by definition, are limited to those that are gathered utilizing the sense of sight. Beginning first with the advent of still photography, such sources may include, but are not limited to, photographs, videotapes, motion pictures, and computer-generated animations.

11.3.4 Electronic Information. Computers have become an integral part of modern information and data systems. As such, the computer system maintained by any particular source of information may provide a wealth of information relevant to the fire investigation.

11.4 Interviews.

11.4.1 Purpose of Interviews. The purpose of any interview is to gather both useful and accurate information. Witnesses can provide such information about the fire and explosion incident even if they were not eyewitnesses to the incident.

A fire or explosion investigation is a complex endeavor involving both art and science. The compilation of factual data, as well as an analysis of those facts, should be accomplished objectively and truthfully. The basic methodology of the fire investigation should rely on the use of a systematic approach and on attention to all relevant details. The use of a systematic approach often will uncover new factual data for analysis, which may require previous conclusions to be re-evaluated. With a few exceptions, the proper methodology for a fire or explosion investigation is first to determine and establish the origin(s), then to investigate the cause: What circumstances, conditions, or agencies caused the ignition source, fuel, and oxidant to come together?

11.4.2 Types of Interviews. Interviews can generally be categorized into three different types. These include interviews with those you can approach with an attitude of trust, interviews with those you should approach with caution, and interviews with those you should approach with an attitude of distrust.

11.4.3 Preparation for the Interview. The fire investigator should be thoroughly prepared prior to conducting any type of interview, especially if the investigator intends to solicit relevant and useful information. The most important aspect of this preparation is a thorough understanding of all facets of the investigation.

The fire investigator should also carefully plan the setting of the interview, that is, when and where the interview will be held. Although the time that the interview is conducted may be determined by a variety of factors, the interview should generally be conducted as soon as possible after the fire or explosion incident. A timely interview will ensure an accurate recollection of the incident by the witness.

It may be helpful to the investigator to conduct preliminary interviews before the fire scene examination commences, although there are many instances when this may be impractical.

The interviewer and the person being interviewed should be properly identified. The interview should, therefore, begin with the proper identification of the person conducting the interview. The date, time, and location of the interview, as well as any witnesses to it, should be documented.

The person being interviewed should also be completely and positively identified. Positive identification may include the person's full name, date of birth, Social Security number, driver's license number, physical description, home address, home telephone number, place of employment, business address, business telephone number, or other information that may be deemed pertinent to establish positive identification.

Lastly, the fire investigator should also establish a flexible plan or outline for the interview.

11.4.4 Interviews with Those You Can Approach with an Attitude of Trust. This type of interview involves those persons whose information can be substantially considered as reliable. Such persons may include, but are not limited to, government officials, representatives of financial institutions, citizen witnesses, and others who have no specific interest in the results of the investigation.

Generally, when preparing to conduct this type of interview, the fire investigator may want to make an appointment to establish a comfortable and cooperative mood. The setting of the interview is not of great importance and, in fact, the interview may be best conducted at the home or office of the person being interviewed to maintain that comfortable and cooperative mood. During the interview itself, the fire investigator should use a flexible checklist to ensure that all necessary information is solicited from the person being interviewed.

11.4.5 Interviews with Those You Should Approach with Caution. This type of interview involves those persons whose information may or may not be considered reliable. Such persons include those who may potentially have a specific interest in the results of the investigation. As such, the fire investigator should be certain to verify the validity of any information solicited during this type of interview. Generally, when preparing to conduct this type of interview, the fire investigator should not make an appointment. This prevents the person being interviewed from preparing responses to inquiries that may be made during the interview. The setting of the interview

becomes more important and, in fact, the fire investigator may wish to conduct the interview in a location where the person being interviewed may not feel so comfortable. Like the previous type of interview, the fire investigator should use a flexible checklist to ensure that all necessary information is solicited from the person being interviewed.

11.4.6 Interviews with Those You Should Approach with an Attitude of Distrust. This type of interview involves those persons whose information should be considered as unreliable unless substantially verified. Such persons include those who have an obvious or documented specific interest in the results of the investigation such as the suspect(s) in an incendiary fire investigation.

Generally, when preparing to conduct this type of investigation, the fire investigator should not make an appointment. This prevents the person being interviewed from preparing responses to inquiries that may be made during the interview. The setting of the interview becomes extremely important and, in fact, the fire investigator should conduct the interview in a location where the investigator feels comfortable. And, like the previous types of interviews, the fire investigator should use a flexible checklist to ensure that all necessary information is solicited from the person being interviewed.

11.4.7 Documenting the Interview. All interviews, regardless of their type, should be documented. Tape recording the interview or taking written notes during the interview are two of the most common methods of documenting the interview. Both of these methods, however, often tend to distract or annoy the person being interviewed, resulting in some information not being solicited from them. An alternative method used to document interviews can be accomplished through the use of visual taping. All taping must be done in accordance with applicable laws and regulations. The investigator should obtain signed written statements from as many witnesses as possible to enhance their admissibility in court.

11.5 Governmental Sources of Information.

11.5.1 Municipal Government.

11.5.1.1 Municipal Clerk. The municipal clerk maintains public records regarding municipal licensing and general municipal business.

11.5.1.2 Municipal Assessor. The municipal assessor maintains public records regarding plats or maps of real property, including dimensions, addresses, owners, and taxable value of the real property and any improvements.

11.5.1.3 Municipal Treasurer. The municipal treasurer maintains public records regarding names and addresses of property owners, names and addresses of taxpayers, legal descriptions of property, amount of taxes paid or owed on real and personal property, and former owners of the property.

11.5.1.4 Municipal Street Department. The municipal street department maintains public records regarding maps of the streets; maps showing the locations of conduits, drains, sewers, utility conduits; correct street numbers; old names of streets; abandoned streets and rights-of-way; and alleys, easements, and rights-of-way.

11.5.1.5 Municipal Building Department. The municipal building department maintains public records regarding building permits, electrical permits, plumbing permits, blueprints, and diagrams showing construction details and records of various municipal inspectors.

11.5.1.6 Municipal Health Department. The municipal health department maintains public records regarding birth certificates, death certificates, records of investigations related to pollution and other health hazards, and records of health inspectors.

11.5.1.7 Municipal Board of Education. The municipal board of education maintains public records regarding all aspects of the public school system.

11.5.1.8 Municipal Police Department. The municipal police department maintains public records regarding local criminal investigations and other aspects of the activities of that department.

11.5.1.9 Municipal Fire Department. The municipal fire department maintains public records regarding fire incident reports, emergency medical incident reports, records of fire inspections, and other aspects of the activities of that department.

11.5.1.10 Other Municipal Agencies. Many other offices, departments, and agencies typically exist at the municipal level of government. The fire investigator may encounter different governmental structuring in each municipality. As such, the fire investigator may need to solicit information from these additional sources.

11.5.2 County Government.

11.5.2.1 County Recorder. The county recorder's office maintains public records regarding documents relating to real estate transactions, mortgages, certificates of marriage and marriage contracts, divorces, wills admitted to probate, official bonds, notices of mechanics' liens, birth certificates, death certificates, papers in connection with bankruptcy, and other such writings as are required or permitted by law.

11.5.2.2 County Clerk. The county clerk maintains public records regarding naturalization records, civil litigation records, probate records, criminal litigation records, and records of general county business.

11.5.2.3 County Assessor. The county assessor maintains public records such as plats or maps of real property in the county, which include dimensions, addresses, owners, and taxable value.

11.5.2.4 County Treasurer. The county treasurer maintains public records regarding names and addresses of property owners, names and addresses of taxpayers, legal descriptions of property, amounts of taxes paid or owed on real and personal property, and all county fiscal transactions.

11.5.2.5 County Coroner/Medical Examiner. The county coroner/medical examiner maintains public records regarding the names or descriptions of the deceased, dates of inquests, property found on the deceased, causes and manners of death, and documents regarding the disposition of the deceased.

11.5.2.6 County Sheriff's Department. The county sheriff's department maintains public records regarding county criminal investigations and other aspects of the activities of that department.

11.5.2.7 Other County Agencies. Many other offices, departments, and agencies typically exist at the county level of government. The fire investigator may encounter different governmental structuring in each county. As such, the fire

investigator may need to solicit information from these additional sources.

11.5.3 State Government.

11.5.3.1 Secretary of State. The secretary of state maintains public records regarding charters and annual reports of corporations, annexations, and charter ordinances of towns, villages, and cities; trade names and trademarks registration; notary public records; and Uniform Commercial Code (UCC) statements.

11.5.3.2 State Treasurer. The state treasurer maintains public records regarding all state fiscal transactions.

11.5.3.3 State Department of Vital Statistics. The state department of vital statistics maintains public records regarding births, deaths, and marriages.

11.5.3.4 State Department of Revenue. The state department of revenue maintains public records regarding individual state tax returns; corporate state tax returns; and past, present, and pending investigations.

11.5.3.5 State Department of Regulation. The state department of regulation maintains public records regarding names of professional occupation license holders and their backgrounds; results of licensing examinations; consumer complaints; past, present, or pending investigations; and the annual reports of charitable organizations.

11.5.3.6 State Department of Transportation. The state department of transportation maintains public records regarding highway construction and improvement projects, motor vehicle accident information, motor vehicle registrations, and driver's license testing and registration.

11.5.3.7 State Department of Natural Resources. The state department of natural resources maintains public records regarding fish and game regulations, fishing and hunting license data, recreational vehicles license data, waste disposal regulation, and environmental protection regulation.

11.5.3.8 State Insurance Commissioner's Office. The state insurance commissioner's office maintains public records regarding insurance companies licensed to transact business in the state; licensed insurance agents; consumer complaints; and records of past, present, or pending investigations.

11.5.3.9 State Police. The state police maintain public records regarding state criminal investigations and other aspects of the activities of that agency.

11.5.3.10 State Fire Marshal's Office. The state fire marshal's office maintains public records regarding fire inspection and prevention activities, fire incident databases, and fire investigation activities.

11.5.3.11 Other State Agencies. Many other offices, departments, and agencies typically exist at the state level of government. The fire investigator may encounter different governmental structuring in each state. As such, the fire investigator may need to solicit information from these additional sources.

11.5.4 Federal Government.

11.5.4.1 Department of Agriculture. Under this department, the Food Stamps and Nutrition Services Agency maintains public records regarding food stamps and their issuance.

The Consumer and Marketing Service maintains public records regarding meat inspection, meat packers and stockyards, poultry inspection, and dairy product inspection.

The U.S. Forest Service maintains public records regarding forestry and mining activities.

The investigative activities of the Department of Agriculture are contained in the Office of the Inspector General. The investigative area of the Secretary of Agriculture is the Office of Investigations.

11.5.4.2 Department of Commerce. Under this department, the Bureau of Public Roads maintains public records regarding all highway programs in which federal assistance was given.

The National Marine Fisheries Service maintains public records regarding the names, addresses, and registration of all ships fishing in local waters.

The Commercial Intelligence Division Office maintains public records regarding trade lists, trade contract surveys, and world trade directory reports.

The U.S. Patent Office maintains public records regarding all patents issued in the United States, as well as a roster of attorneys and agents registered to practice before that office.

The Trade Mission Division maintains public records regarding information on members of trade missions.

The investigative activities of the Department of Commerce are contained in the Office of Investigations and Security.

11.5.4.3 Department of Defense. The Department of Defense oversees all of the military branches of the armed services including the Army, the Navy, the Marine Corps, the Air Force, and the Coast Guard. Each of these branches of the military maintains public records regarding its activities and personnel. Each of these branches has offices that conduct criminal investigations within its specific branch of armed service.

11.5.4.4 Department of Health and Human Services. Under this department, the Food and Drug Administration maintains public records regarding its enforcement of federal laws under its jurisdiction.

The Social Security Administration maintains public records with regard to its activities.

The investigative activities of the Department of Health and Human Services are contained in the Office of Security and Investigations.

11.5.4.5 Department of Housing and Urban Development. The Department of Housing and Urban Development maintains public records regarding all public housing programs in which federal assistance has been given. The investigative activities of the Department of Housing and Urban Development are contained in the compliance division.

11.5.4.6 Department of the Interior. Under this department, the Fish and Wildlife Service maintains public records regarding violations of federal laws related to fish and game.

The Bureau of Indian Affairs maintains public records regarding censuses of Indian reservations, names, degree of Indian blood, tribe, family background, and current addresses of all Indians, especially those residing on federal Indian reservations.

The National Park Service maintains public records regarding all federally owned or federally maintained parks and lands.

Each division of the Department of Interior has its own investigative office.

11.5.4.7 Department of Labor. Under this department, the Labor Management Services Administration maintains public records regarding information on labor and management organizations and their officials.

The Employment Standards Administration maintains public records regarding federal laws related to minimum wage, overtime standards, equal pay, and age discrimination in employment.

The investigative activities of the Department of Labor are contained in the Labor Pension Reports Office Division.

11.5.4.8 Department of State. The Department of State maintains public records regarding passports, visas, and import/export licenses.

The investigative activities of the Department of State are contained in the Visa Office.

11.5.4.9 Department of Transportation. Under this department, the Environmental Safety and Consumer Affairs Office maintains public records regarding its programs to protect the environment, to enhance the safety and security of passengers and cargo in domestic and international transport, and to monitor the transportation of hazardous and dangerous materials.

The United States Coast Guard maintains public records regarding persons serving on U.S. registered ships, vessels equipped with permanently installed motors, vessels over 16 ft (4.9 m) long equipped with detachable motors, information on where and when ships departed or returned from U.S. ports, and violations of environmental laws.

11.5.4.10 Department of the Treasury. Under this department, the Bureau of Alcohol, Tobacco, and Firearms maintains public records regarding distillers, brewers, and persons or firms that manufacture or handle alcohol; retail liquor dealers; manufacturers and distributors of tobacco products; firearms registration; federal firearms license holders, including manufacturers, importers, and dealers; federal explosive license holders, including manufacturers, importers, and dealers; and the origin of all firearms manufactured and imported after 1968.

The U.S. Customs Service maintains public records regarding importers; exporters; customhouse brokers; customhouse truckers; and the registry, enrollment, and licensing of vessels not licensed by the Coast Guard or the United States that transport goods to and from the United States.

The Internal Revenue Service maintains public records regarding compliance with all federal tax laws.

The U.S. Secret Service maintains public records regarding counterfeiting and forgery of U.S. coins and currencies and records of all threats on the life of the president and his immediate family, the vice president, former presidents and their wives, wives of deceased presidents, children of deceased presidents until age sixteen, president- and vice president-elect, major candidates for the office of president and vice president, and heads of states representing foreign countries visiting in the United States.

11.5.4.11 Department of Justice. Under this department, the Antitrust Division maintains public records regarding federal sources of information relating to antitrust matters.

The Civil Rights Division maintains public records regarding its enforcement of all federal civil rights laws that prohibit discrimination on the basis of race, color, religion, or national origin in the areas of education, employment, and housing, and the use of public facilities and public accommodations.

The Criminal Division maintains public records regarding its enforcement of all federal criminal laws except those specifically assigned to the Antitrust, Civil Rights, or Tax Divisions.

The Drug Enforcement Administration maintains public records regarding all licensed handlers of narcotics, the legal trade of narcotics and dangerous drugs, and its enforcement of federal laws relating to narcotics and other drugs.

The Federal Bureau of Investigation maintains public records regarding criminal records, fingerprints, and its enforcement of federal criminal laws.

The Immigration and Naturalization Service maintains public records regarding immigrants, aliens, passengers and crews on vessels from foreign ports, naturalization records, deportation proceedings, and the financial statements of aliens and persons sponsoring their entry into the United States.

11.5.4.12 U.S. Postal Service. The U.S. Postal Service maintains public records regarding all of its activities. The investigative activities of the U.S. Postal Service are contained in the Office of the Postal Inspector.

11.5.4.13 Department of Energy. The Department of Energy is an executive department of the U.S. government that works to meet the nation's energy needs. The department develops and coordinates national energy policies and programs. It promotes conservation of fuel and electricity. It also conducts research to develop new energy sources and more efficient ways to use present supplies. The secretary of energy, a member of the president's cabinet, heads the department.

11.5.4.14 United States Fire Administration. The United States Fire Administration maintains an extensive database of information related to fire incidents through its administration of the National Fire Incident Reporting System (NFIRS).

In addition, the administration maintains records of ongoing research in fire investigation, information regarding arson awareness programs, and technical and reference materials focusing on fire investigation, and it coordinates the distribution of the Arson Information Management System (AIMS) software.

11.5.4.15 National Oceanic and Atmospheric Administration. Weather data, past or present, for all reporting stations in the United States are available from the National Climatic Data Center in Asheville, NC. Local NOAA weather stations can provide data for their areas.

11.5.4.16 Other Federal Agencies. There is a variety of other federal agencies and commissions that are part of the federal level of government. These federal agencies and commissions all maintain a variety of public records. As such, the fire investigator may need to solicit information from these additional sources. The U.S. Senate Committee on Government Operations publishes a handy reference entitled *Chart of the Organization of Federal Executive Departments and Agencies*. This chart provides the exact name of an office, division, or bureau, and the place it occupies in the organizational structure in a department or agency. With this reference, it should not be difficult for the fire investigator to determine the jurisdiction of a federal government agency or commission.

11.6 Private Sources of Information.

11.6.1 NFPA (National Fire Protection Association). NFPA was organized in 1896 to promote the science of and improve the methods of fire protection and prevention, to obtain and circulate information on these subjects, and to secure the

cooperation of its members in establishing proper safeguards against loss of life and property. NFPA is an international, charitable, technical, and educational organization.

NFPA is responsible for the development and distribution of the *National Fire Codes*[®]. In addition to these, NFPA has developed and distributed a wealth of technical information, much of which is of significant interest to the fire investigator.

11.6.2 Society of Fire Protection Engineers (SFPE). Organized in 1950, the Society of Fire Protection Engineers is a professional organization for engineers involved in the multifaceted field of fire protection. The society works to advance fire protection engineering and its allied fields, to maintain a high ethical standard among its members, and to foster fire protection engineering education.

11.6.3 American Society for Testing and Materials (ASTM). The American Society for Testing and Materials, founded in 1898, is a scientific and technical organization formed for "the development of standards on characteristics and performance of materials, products, systems, and services, and the promotion of related knowledge." It is the world's largest source of voluntary consensus standards.

Many of these standards focus on acceptable test methods for conducting a variety of fire-related tests often requested by fire investigators. Those standards that outline fire tests are discussed in Chapter 14 of this document.

11.6.4 National Association of Fire Investigators (NAFI). The National Association of Fire Investigators was organized in 1961. Its primary purposes are to increase the knowledge of and improve the skills of persons engaged in the investigation and analysis of fires and explosions, or in the litigation that ensues from such investigations.

The Association also originated and implemented the National Certification Board. Each year, the board certifies fire and explosion investigators and fire investigation instructors. Through this program, those certified are recognized for their knowledge, training, and experience and accepted for their expertise.

11.6.5 International Association of Arson Investigators (IAAI). The International Association of Arson Investigators was founded in 1949 by a group of public and private officials to address fire and arson issues. The purpose of the association is to strive to control arson and other related crimes, through education and training, in addition to providing basic and advanced fire investigator training. The IAAI has chapters located throughout the world.

In addition to an annual seminar, there are also regional seminars focusing on fire investigator training and education. The Association publishes the *Fire and Arson Investigator*, a quarterly magazine. The IAAI offers a written examination for investigators meeting IAAI minimum qualifications to become an IAAI-certified fire investigator (CFI).

11.6.6 Regional Fire Investigations Organizations. In addition to the National Association of Fire Investigators, the International Association of Arson Investigators, and its state chapters, many regional fire investigation organizations exist. These organizations generally exist as state or local fire/arson task forces, professional societies or groups of fire investigators, or mutual aid fire investigation teams.

11.6.7 Real Estate Industry. The real estate industry maintains certain records that may prove beneficial to the fire investigator during the investigation. Besides records of persons

and businesses that are selling or purchasing property, real estate offices often maintain extensive libraries of photographs of homes and businesses located in their sales territory. These photographs may be of interest to the fire investigator.

11.6.8 Abstract and Title Companies. Abstract and title companies are another valuable source of information. Records maintained by such companies include maps and tract books; escrow indexes of purchasers and sellers of real estate; escrow files containing escrow instructions, agreements, and settlements; and abstract and title policies.

11.6.9 Financial Institutions. Financial institutions, including banks, savings and loan associations, brokers, transfer agents, dividend disbursing agents, and commercial lending services, all maintain records that serve as sources of valuable information. Besides the financial information about a particular person or business, the records of financial institutions contain other information about all facets of a person's life or a business's history.

11.6.10 Insurance Industry. The insurance industry certainly has an interest in the results of most fire and explosion incidents. The industry's primary interest in such investigations is the detection of the crime of arson and other fraud offenses. The insurance industry can, however, also provide the fire investigator with a diverse amount of information concerning the structure involved or vehicle and the person(s) who have insured it. (*See Section 9.5.*)

The insurance industry also funds the Property Insurance Loss Register (PILR), which receives reports of property losses through fire, burglaries, and thefts. It is a computerized index of the insurance companies that paid the claims, the person to whom the claim was paid, the type of claim, and the like. It can serve as a valuable source of information to the fire investigator.

11.6.11 Educational Institutions. Educational institutions are not often considered as a source of information by fire investigators. The records maintained by such institutions can, however, provide an insight into a person's background and interests.

11.6.12 Utility Companies. During the normal course of business, utility companies maintain extensive databases, particularly concerning their customers. The fire investigator should not overlook that these companies, whether publicly owned or private, also maintain records concerning the quality of and problems associated with the distribution of their products or services.

11.6.13 Trade Organizations. Trade organizations are often one of the most valuable sources of information available to the fire investigator. These organizations promote the interest of many of the prominent trades. Their value to the fire investigator is that each organization focuses on a specific trade or discipline. As such, they often function as clearinghouses for knowledge in their area of expertise. Besides this expertise, most trade organizations develop and distribute publications that serve as important reference materials to the fire investigator.

11.6.14 Local Television Stations. Local TV stations often send camera crews to newsworthy fires. Copies of their videotape coverage may be obtained, if still available. TV stations also have records of the weather in the area and often have limited data from local amateur weather watchers from areas away from the airports.

11.6.15 Lightning Detection Networks. Lightning detection networks exist that may assist in the establishing of the time and location [to within 500 m (1640.4 ft)] of a lightning strike. Historical data is also available, including reports of any lightning strikes detected within a specified time prior to a fire.

11.6.16 Other Private Sources. There are a variety of other private sources of information. These private sources all maintain a variety of records. As such, the fire investigator may need to solicit information from these additional sources.

11.7 Conclusion. The number and diversity of governmental and private sources of information for the fire investigator is unlimited. While not a comprehensive listing, by any means, those sources of information enumerated in this chapter should provide the fire investigator with a realization that his or her ability to solicit information pertinent to a particular fire investigator is also unlimited.

Chapter 12 Planning the Investigation

12.1 Introduction. The intent of this chapter is to identify basic considerations of concern to the investigator prior to beginning the incident scene investigation.

Regardless of the number of people involved, the need to preplan investigations remains constant. Considerations for determining the number of investigators assigned include budgetary constraints, available staffing, complexity, loss of life, and size of the scene to be investigated.

The person responsible for the investigation of the incident should identify the resources at his or her disposal and those available from outside sources before those resources are needed. It is his or her responsibility to acquire additional resources as needed. Assistance can be gained from local or state building officials, universities and state colleges, and numerous other public and private agencies.

The "team concept" of investigating an incident is recommended. It is understood that at many incident scenes, the investigator may have to photograph, sketch the scene, collect evidence, interview, and be responsible for the entire scene investigation without other assistance. These functions and others described in this document should be performed regardless of the number of people involved with the investigation.

12.2 Basic Incident Information. Prior to beginning the incident scene investigation, numerous events, facts, and circumstances should be identified. Accuracy is important, since a mistake at this point could jeopardize the subsequent investigation results.

12.2.1 Location. The investigator, once notified of an incident, should obtain as much background information as possible relative to the incident from the notifier. If the travel distance is great, arrangements may be required to transport the investigation team to the incident scene.

The location of the incident may also dictate the need for specialized equipment and facilities. (*See 12.4.1.*)

12.2.2 Date and Time of Incident. The investigator should accurately determine the day, date, and time of the incident. The age of the scene may have an effect on the planning of the investigation. The greater the delay between the incident and the investigation, the more important it becomes to review pre-existing documentation and information such as incident reports, photographs, building plans, and diagrams.

12.2.3 Weather Conditions. Weather at the time of the investigation may necessitate the need for special clothing and equipment. Weather may also determine the amount of time the team members can work an incident scene. Extreme weather may also require that greater safety precautions be taken on behalf of the team members, for example, when the weight of snow on a structure weakens it.

Weather conditions such as wind direction and velocity, temperature, and rain during a fire should be noted because all can have an effect on the ignition and fire spread.

12.2.4 Size and Complexity of Incident. The size and complexity of the incident scene may suggest the need for assistance for the investigator. A large incident scene area may create communication problems for investigators, and arrangements for efficient communications should be made.

The size and complexity of the scene will also affect the length of the investigation, and preparations may be needed for housing and feeding the team members. Generally, the larger the incident scene, the greater the length of time required to conduct the investigation.

12.2.5 Type and Use of Structure. The investigator should identify the type and use of the incident structure. The use or occupancy of the structure (e.g., industrial plant, chemical processing plant, storage warehouse, nuclear facility, or radiological waste storage) may necessitate special containment of debris, contamination, or radiation, including water run-off at the scene. Additionally, appropriate hazardous materials or contamination clothing, breathing apparatus, and other protective devices and equipment may be necessary to ensure safety at the incident scene. Conditions at certain scenes may be so hazardous that the investigators should work within monitored stay times.

Knowledge of the type of construction and construction materials will provide the investigator with valuable background information and allow anticipation of circumstances and problems to be encountered by the investigation team.

12.2.6 Nature and Extent of Damage. Information on the condition of the scene may alert the investigator to special requirements for the investigation, such as utility testing equipment, specialized expertise, additional staffing, and special safety equipment. The investigator may be operating under time constraints and should plan accordingly.

12.2.7 Security of Scene. The investigator should promptly determine the identity of the individual, authority, or entity that has possession or control of the scene. Right of access and means of access should be established.

Scene security is a consideration. If possible, arrangements should be made to preserve the scene until the arrival of the investigator(s). If this is not possible, arrangements should be made to photograph and document existing conditions prior to disturbance or demolition.

12.2.8 Purpose of Investigation. While planning the investigation, the investigator should remain aware of his or her role, scope, and areas of responsibility. Numerous investigators may be involved from both the private and public sectors. Mutual respect and cooperation in the investigation is required.

12.3 Organizing the Investigation Functions. There are basic functions that are commonly performed in each investigation. These are the leadership/coordinating function; photography, note taking, mapping, and diagramming (*see Chapter 13*); interviewing witnesses (*see Chapter 11*); searching the scene (*see*

Chapter 15); evidence collection and preservation (*see Chapter 14*); and safety assessment (*see Chapter 10*).

In addition, specialized expertise in such fields as electrical, heating and air conditioning, or other engineering fields is often needed. The investigator should, if possible, fulfill these functions with the personnel available. In assigning functions, those special talents or training that individual members possess should be utilized.

12.4 Preinvestigation Team Meeting. If the investigator has established a team, a meeting should take place prior to the on-scene investigation. The team leader or investigator should address questions of jurisdictional boundaries and assign specific responsibilities to the team members. Personnel should be advised of the condition of the scene and the safety precautions required.

12.4.1 Equipment and Facilities. Each person on the fire scene should be equipped with appropriate safety equipment, as required. A complement of basic tools should also be available. The tools and equipment listed below may not be needed on every scene, but in planning the investigation, the investigator should know where to obtain these tools and equipment if the investigator does not carry them.

Personal Safety Equipment

- Eye protection
- Flashlight
- Gloves
- Helmet or hard hat
- Respiratory protection (type depending on exposure)
- Safety boots or shoes
- Turnout gear or coveralls

Tools and Equipment

- Absorption material
- Axe
- Broom
- Camera and film (*See 13.2.2.1 and 13.2.2.2 for recommendations.*)
- Claw hammer
- Directional compass
- Evidence-collecting container (*See Section 14.5 for recommendations.*)
- Evidence labels (sticky)
- Hand towels
- Hatchet
- Hydrocarbon detector
- Ladder
- Lighting
- Magnet
- Marking pens
- Paint brushes
- Paper towels/wiping cloths
- Pen knife
- Pliers/wire cutters
- Pry bar
- Rake
- Rope
- Rulers
- Saw
- Screwdrivers (multiple types)
- Shovel

Sieve
 Soap and hand cleaner
 Styrofoam cups
 Tape measure
 Tape recorder
 Tongs
 Tweezers
 Twine
 Voltmeter/ohmmeter
 Water
 Writing/drawing equipment

12.5 Specialized Personnel and Technical Consultants. In planning a fire investigation, specialized personnel may be needed to provide technical assistance. There are many different facets to fire investigation. If unfamiliar with a particular aspect, the investigator should never hesitate to call in another fire investigative expert who has more knowledge or experience in a particular aspect of the investigation. For example, there are some experts who specialize in explosions.

Sources for these specialized personnel/experts include colleges or universities, government agencies (federal, state, and local), societies or trade groups, consulting firms, and others. When bringing in specialized personnel, it is important to remember that conflict of interest should be avoided. Identification of special personnel in advance is recommended. The following paragraphs list examples of professional or specific engineering and scientific disciplines, along with areas where these personnel may help the fire investigator. This section is not intended to list all sources for these specialized personnel and technical consultants.

It should be kept in mind that fire investigation is a specialized field. Those individuals not specifically trained and experienced in the discipline of fire investigation and analysis, even though they may be expert in related fields, may not be well qualified to render opinions regarding fire origin and cause. In order to offer origin and cause opinions, additional training or experience is generally necessary.

The following descriptions are general and do not imply that the presence or absence of a referenced area of training affects the qualifications of a particular specialist.

12.5.1 Materials Engineer or Scientist. A person in this field can provide specialized knowledge about how materials react to different conditions, including heat and fire. In the case of metals, someone with a metallurgical background may be able to answer questions about corrosion, stress, failure or fatigue, heating, or melting. A polymer scientist or chemist may offer assistance regarding how plastics react to heat and other conditions present during a fire and regarding the combustion and flammability properties of plastics.

12.5.2 Mechanical Engineer. A mechanical engineer may be needed to analyze complex mechanical systems or equipment, including heating, ventilation, and air conditioning (HVAC) systems, especially how these systems may have affected the movement of smoke within a building. The mechanical engineer may also be able to perform strength-of-material tests.

12.5.3 Electrical Engineer. An electrical engineer may provide information regarding building fire alarm systems, energy systems, power supplies, or other electrical systems or components. An electrical engineer may assist by quantifying the normal operating parameters of a particular system and determining failure modes.

12.5.4 Chemical Engineer/Chemist. A chemical engineer has education in chemical processes, fluid dynamics, and heat transfer. When a fire involves chemicals, a chemical process, or a chemical plant, the chemical engineer may help the investigator identify and analyze possible failure modes.

A chemist has extensive education in the identification and analysis of chemicals and may be used by the investigator in identifying a particular substance found at a fire scene. The chemist may be able to test a substance to determine its chemical and physical reaction to heat. When there are concerns about toxicity or the human reaction to chemicals or chemical decomposition products, a chemist, biochemist, or microbiologist should be consulted by the investigator.

12.5.5 Fire Science and Engineering. Within the field of fire science and engineering, there are a number of areas of special expertise that can provide advice and assistance to the investigator.

12.5.5.1 Fire Protection Engineer. Fire protection engineering encompasses all the traditional engineering disciplines in the science and technology of fire and explosions. The fire protection engineer deals with the relationship of ignition sources to materials in determination of what may have started the fire. He or she is also concerned with the dynamics of fire, and how it affects various types of materials and structures. The fire protection engineer should also have knowledge of how fire detection and suppression systems (e.g., smoke detectors, automatic sprinklers, or halon systems) function and should be able to assist in the analysis of how a system may have failed to detect or extinguish a fire. The complexity of fire often requires the fire protection engineer to use many of the other engineering and scientific disciplines to study how a fire starts, grows, and goes out. Additionally, a fire protection engineer should be able to provide knowledge of building and fire codes, fire test methods, fire performance of materials, computer modeling of fires, and failure analysis.

12.5.5.2 Fire Engineering Technologist. Individuals with bachelor of science degrees in fire engineering technology, fire and safety engineering technology, or a similar discipline, or recognized equivalent, typically have studied fire dynamics and fire science; fire and arson investigation, fire suppression technology, fire extinguishment tactics, and fire department management; fire protection; fire protection structures and systems design; fire prevention; hazardous materials; applied upper-level mathematics and computer science; fire-related human behavior; safety and loss management; fire and safety codes and standards; and fire science research.

12.5.5.3 Fire Engineering Technician. Individuals with associate of science level degrees in fire and safety engineering technology or similar disciplines, or recognized equivalent, typically may have studied fire dynamics and fire science; fire and arson investigation; fire suppression technology, tactics, and management; fire protection; fire protection structures and systems design; fire prevention; hazardous materials; mathematics and computer science topics; fire-related human behavior; safety and loss management; fire and safety codes and standards; or fire science research.

12.5.6 Industry Expert. When the investigation involves a specialized industry, piece of equipment, or processing system, an expert in that field may be needed to fully understand the processes involved. Experience with the specific fire hazards involved and the standards or regulations associated with the industry and its equipment and processes can provide

valuable information to the investigator. Industry experts can be found within companies, trade groups, or associations.

12.5.7 Attorney. An attorney can provide needed legal assistance with regard to rules of evidence, search and seizure laws, gaining access to a fire scene, and obtaining court orders.

12.5.8 Insurance Agent/Adjuster. An insurance agent or adjuster may be able to provide the investigator with information concerning the building and its contents prior to the fire, fire protection systems in the building, and the condition of those systems. Additional information regarding insurance coverage and prior losses may be available.

12.5.9 Canine Teams. Trained canine/handler teams may assist investigators in locating areas for collection of samples for laboratory analysis to identify the presence of ignitable liquids.

12.6* Case Management. A method should be employed to organize the information generated throughout the investigation and to coordinate the efforts of the various people involved. This topic of case management is addressed in the context of major loss investigations in Chapter 24 of this guide. It is also the focus of some of the reference material listed at the back of this guide.

Chapter 13 Recording the Scene

13.1* Introduction. In recording any fire or explosion scene, the investigator's goal is to record the scene through a medium that will allow the investigator to recall his or her observations at a later date and to document the conditions at the scene. Common methods of accomplishing this goal include the use of photographs, videotapes, diagrams, maps, overlays, tape recordings, and notes.

Thorough and accurate recording of the scene is critical because it is from this compilation of factual data that investigative opinions and conclusions will be supported and verified. There are a number of resources to assist the investigator in recording the scene.

13.2 Photography. A visual documentation of the fire scene can be made using either film or video photography. Images can portray the scene better than words. They are the most efficient reminders of what the investigator saw while at the scene. Patterns and items may become evident that were overlooked at the time the photographs or videos were made. They can also substantiate reports and statements of the investigator.

Taking a basic photography or video course through a vocational school, camera club, or camera store would be most helpful in getting the photographer familiar with the equipment.

As many photographs should be taken as are necessary to document and record the fire scene adequately. It is recognized that time and expense considerations may impact the number of photographs taken, and the photographer should exercise discretion. It is far preferable to err on the side of taking too many photographs rather than too few.

The exclusive use of videotapes, motion pictures, or slides is not recommended. They are more effective when used in conjunction with still photographs. Also, additional equipment is obviously required to review and utilize videos, films, and slides.

13.2.1 Timing. Taking photographs during or as soon as possible after a fire is important when recording the fire scene, as the scene may become altered, disturbed, or even destroyed. Some reasons why time is important include the following.

(a) The building is in danger of imminent collapse or the structure must be demolished for safety reasons.

(b) The condition of the building contents creates an environmental hazard that needs immediate attention.

(c) Evidence should be documented when discovered as layers of debris are removed, as is done at an archaeological dig. Documenting the layers can also assist in understanding the course of the fire.

13.2.2 Basics. The most fundamental aspect of photography that an investigator should comprehend is how a camera works. The easiest way to learn how a camera works is to compare the camera to the human eye.

One of the most important aspects to remember about fire investigation photography is light. The average fire scene consists of blackened subjects and blackened background, creating much less than ideal conditions for taking a photograph. As one can imagine, walking into a dark room causes the human eye to expand its pupil in order to gather more light; likewise, the camera requires similar operation. The person in a dark room normally turns on the light to enhance vision, just as a photographer uses flash or floodlight to enhance the imitated vision of the camera.

Both the human eye and the camera project an inverted image on the light-sensitive surface: the film in the camera, and the retina in the eye. The amount of light admitted is regulated by the iris (eye) or diaphragm (camera). In both, the chamber through which the light passes is coated with a black lining to absorb the stray light and avoid reflection.

Regardless of camera type, film speed, or whether slides or prints are being taken, it is recommended that the investigator use color film. The advantage of color film is that the final product can more realistically depict the fire scene by showing color variations between objects and smoke stains.

13.2.2.1 Types of Cameras. There is a multitude of camera types available to the investigator, from small, inexpensive models to elaborate versions with a wide range of attachments.

Some cameras are fully automatic, giving some investigators a sense of comfort knowing that all they need to do is point and shoot. These cameras will set the film speed from a code on the film canister, adjust the lens opening (f-stop), and focus the lens by means of a beam of infrared light.

Manual operation is sometimes desired by the investigator so that specialty photographs can be obtained that the automatic camera, with its built-in options, cannot perform. For example, with a manual camera, bracketing (taking a series of photographs with sequentially adjusted exposures) can be performed to ensure at least one properly exposed photograph when the correct exposure is difficult to measure. There are some cameras that can be operated in a manual as well as an automatic mode, providing a choice from the same camera. Most investigators prefer an automatic camera.

A 35 mm single-lens reflex camera is preferred over other formats, but the investigator who has a non-35 mm camera should continue to take photographs as recommended. A back-up camera that instantly develops prints can be advantageous, especially for an important photograph of a valuable piece of evidence.

13.2.2.2 Film. There are many types of film and film speeds available in both slide and print film. There are numerous speeds of film (ASA ratings) especially in the 35 mm range. Since 35 mm (which designates the size of the film) is most recognized and utilized by fire investigators, film speeds will be discussed using this size only. The common speeds range

from 25 to 1600 in color and to 6400 in black and white. The numbers are merely a rating system. As the numbers get larger, the film requires less light. While the higher ASA-rated (faster) film is better in low light conditions with no flash, a drawback is that it will produce poorer-quality enlargements, which will have a grainy appearance. The film with the lowest rating that the investigator is comfortable with should be used because of the potential need for enlargements. Most investigators use a film with an ASA rating between 100 and 400. Fire investigators should practice and become familiar with the type and speed of film they intend to use on a regular basis.

13.2.2.3 Digital Photography. With the advantage of computer-based technology and the improvement of digital cameras and technology, there are a number of issues that have been raised regarding the acceptance of the photograph during testimony. At this time, there are no definitive answers as to the acceptance of these photographs in the courtroom. With all photographs, the tests of a “true and accurate representation” and “relevance to the testimony” must still be met. While digital format is encouraged, due to concerns of admissibility print film should be the primary means of photography. A backup, or redundant photographs using different cameras and format, will provide the investigator with a better opportunity to have essential scene documentation.

When a digital format is chosen, the higher-resolution camera will provide the investigator with photographs of higher quality. Additional considerations for the type of camera selected would be the same as for the selection and use of current still photography (i.e., lens quality, flash, spot meter, and so on). The last aspect concerning the use of digital photography is to use high quality printer and paper when making hard copies of the photographs.

13.2.2.4 Lenses. The camera lens is used to gather light and to focus the image on the surface of the film. Most of today’s lenses are compound, meaning that multiple lenses are located in the same housing. The fire investigator needs a basic understanding of the lens function to obtain quality photographs. The convex surface of the lens collects the light and sends it to the back of the camera, where the film lies. The aperture is an adjustable opening in the lens that controls the amount of light admitted. The adjustments of this opening are sectioned into measurements called f-stops. As the f-stop numbers get larger, the opening gets smaller, admitting less light. These f-stop numbers are listed on the movable ring of the adjustable lenses. Normally, the higher the f-stop that can be used, the better the quality of the photograph.

Focal lengths in lenses range from a normal lens (50 mm, which is most similar to the human eye) to the wide angle (28 mm or less) lenses, to telephoto and zoom lenses (typically 100 mm or greater). The investigator needs to determine what focal lengths will be used regularly and become familiar with the abilities of each.

The area of clear definition or depth of field is the distance between the farthest and nearest objects that will be in focus at any given time. The depth of field depends on the distance to the object being photographed, the lens opening, and the focal length of the lens being used. The depth of field will also determine the quality of detail in the investigator’s photographs. For a given f-stop, the shorter the focal length of the lens, the greater the depth of field. For a given focal length lens, a larger f-stop (smaller opening) will provide a greater depth of field. The more the depth of field, the more minute are the details that will be seen. This is an important technique to master. These are the most common lens factors with which

the fire investigator needs to be familiar. If a fixed-lens camera is used, the investigator need not be concerned with adjustments, because the manufacturer has preset the lens. A recommended lens is a medium range zoom, such as the 35 mm to 70 mm, providing a wide angle with a good depth of field and the ability to take high-magnification close-ups (macros).

13.2.2.5 Filters. The investigator should know that problems can occur with the use of colored filters. Unless proper knowledge of their end results is known, it is recommended that they not be used. If colored filters are used, the investigator should take a photograph with a clear filter also. The clear filter can be used continually and is a good means of protecting the lens.

13.2.2.6 Lighting. The most usable light source known is the sun. No artificial light source can compare realistically in terms of color, definition, and clarity. At the beginning and end of the day, inside a structure or an enclosure, or on an overcast day, a substitute light source will most likely be needed. This light can be obtained from a floodlight or from a strobe or flash unit integrated with the camera.

Because a burned area has poor reflective properties, artificial lighting using floodlights is useful. These, however, will need a power source either from a portable generator or from a source within reach by extension cord.

Flash units are necessary for the fire investigator’s work. The flash unit should be removable from the camera body so that it can be operated at an angle oblique to that of the lens view. This practice is valuable in reducing the amount of reflection, exposing more depth perception, and amplifying the texture of the heat- and flame-damaged surfaces. Another advantage to a detachable flash unit is that, if the desired composition is over a larger area, the angle and distance between the flash and the subject can be more balanced.

A technique that will cover a large scene is called photo painting. It can be accomplished by placing the camera in a fixed position with the shutter locked open. A flash unit can be fired from multiple angles, to illuminate multiple subjects or large areas from all angles. The same general effect can be obtained by the use of multiple flash units and remote operating devices called slaves.

For close-up work, a ring flash will reduce glare and give adequate lighting for the subject matter. Multiple flash units can also be used to give a similar effect to the ring flash by placing them to flash at oblique angles.

A photograph of an 18 percent gray card standard may be beneficial for calibration in the printing stages of the photographs and can be photographed at the first frame of a roll of film. It will set the standard of light or flash utilized at each scene.

The investigator should be sure that glare from a flash or floodlight does not distort the actual appearance of an object. For example, smoke stains could appear lighter or nonexistent. In addition, shadows created could be interpreted as burn patterns. Movie lights used with videotapes can cause the same problems as still camera flash units. Using bounce flash, light defusers, or other techniques could alleviate this problem.

The investigator concerned with the potential outcome of a photograph can bracket the exposure. Bracketing is the process of taking the same subject matter at slightly different exposure settings to ensure at least one correct exposure.

13.2.2.7 Special Types of Photography. Today’s technology has produced some specialty types of photography. Infrared, laser, and microscopic photography can be used under controlled circumstances. An example is the ability of laser photography to document a latent fingerprint found on a body.

13.2.3 Composition and Techniques. Photographs may be the most persuasive factor in the acceptance of the fire investigator's theory of the fire's evolution.

In fire investigation, a series of photographs should be taken to portray the structure and contents that remain at the fire scene. The investigator generally takes a series of photographs, working from the outside toward the inside of a structure, as well as from the unburned toward the most heavily burned areas. The concluding photographs are usually of the area and point of origin, as well as any elements of the cause of the fire.

It can be useful for the photographer to record, and thereby document, the entire fire scene and not just the suspected point of origin, as it may be necessary to show the degree of smoke spread or evidence of undamaged areas.

13.2.3.1 Sequential Photos. Sequential photographs, shown in Figure 13.2.3.1, are helpful in understanding the relationship of a small subject to its relative position in a known area. The small subject is first photographed from a distant position, where it is shown in context with its surroundings. Additional photographs are then taken increasingly closer until the subject is the focus of the entire frame.

FIGURE 13.2.3.1 Sequential photographs of a chair.



13.2.3.2 Mosaics. A mosaic or collage of photographs can be useful at times when a sufficiently wide angle lens is not available and a panoramic view is desired. It is created by assembling a number of photographs in overlay form to give a more-than-peripheral view of an area, as shown in Figure 13.2.3.2. An investigator needs to identify items (e.g., benchmarks) in the edge of the view finder that will appear in the print and take the next photograph with that same reference point on the opposite side of the view finder. The two prints can then be combined to obtain a wider view than the camera is capable of taking in a single shot.

FIGURE 13.2.3.2 Mosaic of warehouse burn scene from aerial truck.

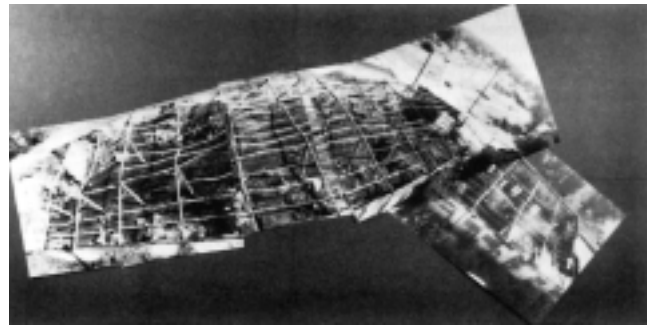

13.2.3.3 Photo Diagram. A photo diagram can be useful to the investigator. When the finished product of a floor plan is complete, it can be copied, and directional arrows can be drawn to indicate the direction from which each of the photographs was taken. Corresponding numbers are then placed on the photographs. This diagram will assist in orienting a viewer who is unfamiliar with the fire scene. A diagram prepared to log a set of photographs might appear as shown in Figure 13.2.3.3.

Recommended documentation includes identification of the photographer, identification of the fire scene (i.e., address or incident number), and the date that the photographs were taken.

The exact time a photograph is taken does not always need to be recorded. There are instances, however, when the time period during which a photograph was taken will be important to an understanding of what the photograph depicts. In photographing an identical subject, natural lighting conditions that exist at noon may result in a significantly different photographic image than natural lighting conditions that exist at dusk. When lighting is a factor, the approximate time or period of day should be noted. Also, the specific time should be noted for any photograph taken prior to extinguishment of the fire, as these often help establish time lines in the fire's progress.

13.2.3.4 Assisting Photographer. If a person other than the fire investigator is taking the photographs, the angles and composition should be supervised by the fire investigator to ensure that shots needed to document the fire are obtained. Investigators should communicate their needs to the photographer, as they may not have a chance to return to the fire scene. The investigators should not assume that the photographer understands what essential photographs are needed without discussing the content of each photo.

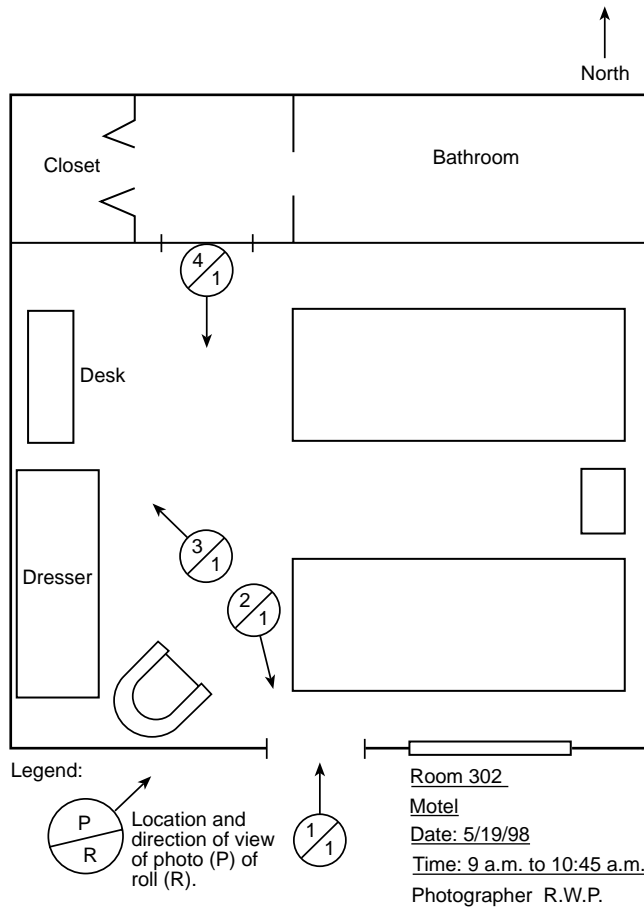
FIGURE 13.2.3.3 Diagram showing photo locations.

13.2.3.5 Photography and the Courts. For the fire investigator to weave photographs and testimony together in the courtroom, one requirement in all jurisdictions is that the photograph should be relevant to the testimony. There are other requirements that may exist in other jurisdictions, including noninflammatory content, clarity of the photograph, or lack of distortion. In most courts, if the relevancy exists, the photograph will usually withstand objections. Since the first color photographs were introduced into evidence in a fire trial, most jurisdictions have not distinguished between color or black and white photographs, if the photograph met all other jurisdictional criteria.

13.2.4 Video. In recent years, advancements have made motion pictures more available to the nonprofessional through the use of video cameras. There are different formats available for video cameras including VHS, BETA, and 8 mm. Video is a very useful tool to the fire investigator. A great advantage to video is the ability to orient the fire scene by progressive movement of the viewing angle. In some ways, it combines the use of the photo diagram, photo indexing, floor plan diagram, and still photos into a single operation.

When taking videos or movies, “zooming-in” or otherwise exaggerating an object should be avoided, as it can be considered to present a dramatic effect rather than the objective effect that is sometimes required for evidence in litigation work.

Another use of video is for interviews of witnesses, owners, occupants, or suspects when the documentation of their testi-

mony is of prime importance. If demeanor is important to an investigator or to a jury, the video can be helpful in revealing that.

The exclusive use of videotape or movies is not recommended, because such types of photography are often considered less objective and less reliable than still photographs. Video should be used in conjunction with still photographs.

Videotape recording of the fire scene can be a method of recording and documenting the fire scene. The investigator can narrate observations, similar to an audio (only) tape recorder, while videorecording the fire scene. The added benefit is that the investigator can better recall the fire scene, specifically fire patterns or artifact evidence, their location, and other important elements of the fire scene. Utilized in this method, the recording is not necessarily for the purpose of later presentation, but is simply another method by which the investigator can record and document the fire scene.

Video recording can also be effective to document the examination of evidence, especially destructive examination. By videotaping the examination, the condition and position of particular elements of evidence can be documented.

13.2.5 Suggested Activities to Be Documented. An investigation may be enhanced if as many aspects of the fire ground activities can be documented as possible or practical. Such documentation may include the suppression activities, overhaul, and the cause and origin investigation.

13.2.5.1 During the Fire. Photographs of the fire in progress should be taken if the opportunity exists. These help show the fire’s progression as well as fire department operations. As the overhaul phase often involves moving the contents and sometimes structural elements, photographing the overhaul phase will assist in understanding the scene before the fire.

13.2.5.2 Crowd or People Photographs. Photographs of people in a crowd are often valuable for identifying individuals who may have additional knowledge that can be valuable to the overall investigation.

13.2.5.3 Fire Suppression Photographs. Fire suppression activities pertinent to the investigation include the operation of automatic systems as well as the activities of the responding fire services, whenever possible. All aspects pertinent to these, such as hydrant locations, engine company positions, hose lays, attack line locations, and so forth, play a role in the eventual outcome of the fire. Therefore, all components of those systems should be photographed.

13.2.5.4 Exterior Photographs. A series of exterior shots should be taken to establish the location of a fire scene. These shots could include street signs or access streets, numerical addresses, or landmarks that can be readily identified and are likely to remain for some time. Surrounding areas that would represent remote evidence, such as fire protection and exposure damage, should also be photographed. Exterior photographs should also be taken of all sides and corners of a structure to reveal all structural members and their relationships with each other. (See Figure 13.2.5.4.)

13.2.5.5 Structural Photographs. Structural photographs document the damage to the structure after heat and flame exposure. Structural photos can expose burn patterns to track the evolution of the fire and can assist in understanding the fire’s origin.

A recommended procedure is to include as much as possible all exterior angles and views of the structure. Oblique

corner shots can give reference points for orientation. Photographs should show all angles necessary for a full explanation of a condition.

Photographs should be taken of structural failures such as windows, roofs, or walls, because such failures can change the route of fire travel and can play a significant role in the eventual outcome of the fire. Code violations or structural deficiencies should also be photographed because fire travel patterns may have resulted from those deficiencies.

FIGURE 13.2.5.4 Photographing the scene from all angles and corners.

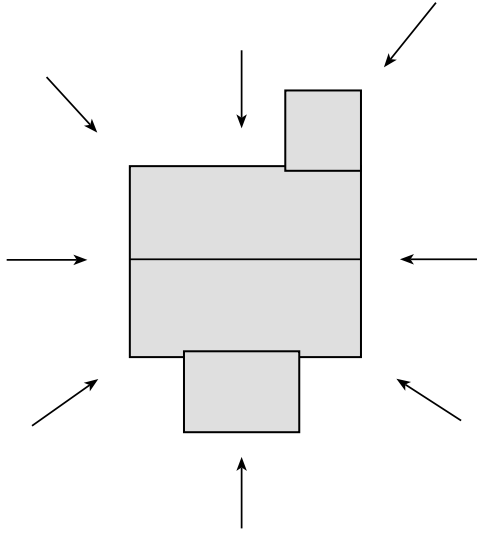

13.2.5.6 Interior Photographs. Interior photographs are equally important. Lighting conditions will likely change from the exterior, calling for the need to adjust technique, but the concerns (tracking and documenting fire travel backward toward the fire origin) are the same. All significant ventilation points accessed or created by the fire should be photographed, as well as all significant smoke, heat, and burn patterns. Figure 13.2.5.6(a) provides a diagram of basic shots.

FIGURE 13.2.5.6(a) Photographing all four walls and both sides of each door.

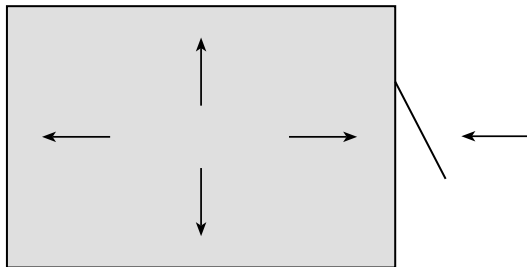

Rooms within the immediate area of the fire origin should be photographed, even if there is no damage. If warranted, closets and cabinet interiors should also be documented. In small buildings, this documentation could involve all rooms; but in large buildings, it may not be necessary to photograph all rooms unless there is a need to document the presence, absence, or condition of contents.

All heat-producing appliances or equipment, such as furnaces, in the immediate area of the origin or connected to the area of origin should be photographed to document their role, if any, in the fire cause.

All furniture or other contents within the area of origin should be photographed as found and again after reconstruction. Protected areas left by any furnishings or other contents should also be photographed, as in the example shown in Figure 13.2.5.6(b).

FIGURE 13.2.5.6(b) Floor tile protected from radiant heat by wire.

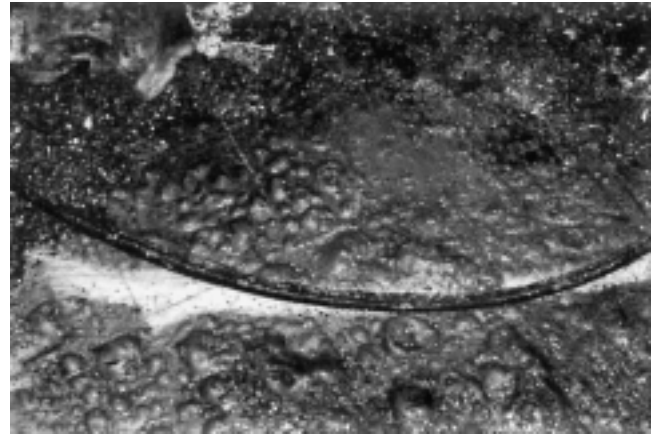

The position of doors and windows during a fire is important, so photographs should be taken that would document those indications and resulting patterns.

Interior fire protection devices such as detectors, sprinklers, extinguishers used, door closers, or dampers should be photographed.

Clocks may indicate the time power was discontinued to them or the time in which fire or heat physically stopped their movement.

13.2.5.7 Utility and Appliance Photographs. The utility (gas, electric) entrances and controls both inside and outside a structure should be photographed. Photos should include gas and electric meters, gas regulators, and their location relative to the structure. The electric utility pole(s) near the structure, and the electrical services coming into the structure, as well as the fuse or circuit breaker panels should also be photographed. If there are gas appliances in the fire area of origin, the position of all controls on the gas appliances should be photographed. When photographing electrical circuit breaker panels, the position of all circuit breaker handles and the panel's schedule indicating what electrical equipment is supplied by each breaker, when available, should be photographed. Likewise, all electrical cords and convenience outlets pertinent to the fire's location should be photographed.

13.2.5.8 Evidence Photographs. Items of evidentiary value should be photographed at the scene and can be rephotographed at the investigator's office or laboratory if a more detailed view is needed. During the excavation of the debris strata, articles in the debris may or may not be recognized as evidence. If photographs are taken in an archaeological manner, the location and position of evidence that can be of vital importance will be documented permanently. Photographs orient the articles of evidence in their original location as well as show

their condition when found. Evidence is essential in any court case, and the photographs of evidence stand strong with proper identification. In an evidentiary photograph, a ruler can be used to identify relative size of the evidence. Other items can also be used to identify the size of evidence as long as the item is readily identifiable and of constant size (e.g., a penny). A photograph should be taken of the evidence without the ruler or marker prior to taking a photograph with the marker.

13.2.5.9 Victim Photographs. The locations of occupants should be documented, and any evidence of actions taken or performed by those occupants should be photographed. This documentation should include marks on walls, beds victims were occupying, or protected areas where a body was located. (See Figure 13.2.5.9.) If there is a death involved, the body should be photographed. Surviving victims' injuries and their clothing worn should also be photographed.

FIGURE 13.2.5.9 Protected area where body was located.



13.2.5.10 Witness Viewpoint Photographs. During an investigation, if witnesses surface and give testimony as to what they observed from a certain vantage point, a photograph should be taken from the most identical view available. This photograph will orient all persons involved with the investigation as well as a jury to the direction of the witnesses' observations and could support or refute the possibility of their seeing what they said they saw.

13.2.5.11 Aerial Photographs. Views from a high vantage point, which can be an aerial fire apparatus, adjacent building, or hill, or from an airplane or helicopter, can often reveal fire spread patterns. Aerial photography can be expensive, and a number of special problems exist that can affect the quality of the results. It is suggested that the investigator seek the advice or assistance of an experienced aerial photographer when such photographs are desired.

13.2.6 Photography Tips. Investigators may help themselves by applying some or all of the following photography tips.

(a) Upon arrival at a fire scene and after shooting an 18 percent gray card, photograph a written "title sheet" that

shows identifying information (i.e., location, date, or situational information).

(b) Label the film canister after each use to prevent confusion or loss.

(c) If the investigator's budget will allow, bulk film can be purchased and loaded into individual canisters that can allow for specific needs in multiple roll sizes and can be less expensive in certain situations.

(d) Carry a tripod that will allow for a more consistent mosaic pattern, alleviate movement and blurred photographs, and assist in keeping the camera free of fire debris. A quick-release shoe on the tripod will save time.

(e) Do not combine multiple fire incidents on one roll of film. Complete each fire scene and remove the last roll from the camera before leaving the scene. This will eliminate potential confusion and problems later on.

(f) Carry extra batteries, especially in cold weather when they can be drained quickly. Larger and longer-life battery packs and battery styles are available.

(g) Remember not to leave the batteries in the photography equipment for an extended period of time. Leaking batteries can cause a multitude of problems to electrical and mechanical parts.

(h) Avoid obstruction of the flash or lens by hands, camera strap, or parts of the fire scene. Additionally, when the camera is focused and ready to shoot, both eyes should be opened to determine whether the flash went off.

13.2.7 Presentation of Photograph. There is a variety of methodologies available to the investigator for the presentation of reports, diagrams, and photographs. A key to the decision making process is: "What method of presentation shows or presents the item with the greatest clarity?" A secondary consideration to assist in the preparation of the presentation is to follow guidelines or practices that are used for instructional presentations, specifically in the area of instructional aids. The investigator should determine what methods of presentation and types of photographs currently are acceptable to the court. Additionally, the investigator should identify and obtain equipment that may be needed to support the presentation, oversee the setup, and test the equipment prior to use.

Preparation is one of the most important aspects of presenting demonstrative evidence.

13.2.7.1 Prints versus Slides. There are advantages and disadvantages to both prints and slides. A benefit of slides over prints is that large size images may be displayed at no additional cost. When showing slides in court, the investigator can keep every juror's attention on what the investigator is testifying about. If prints are utilized, the investigator's testimony may be recalled only vaguely, if the jury member is busy looking at photographs that are passed among the jurors as testimony continues. The use of poster-sized enlargements can help.

Conversely, during testimony of a long duration or during detailed explanations of the scene, slides are a burden to refer to without the use of a projector. In this case, photographs are easier to handle and analyze. When slides are used, problems can occur, such as the slides jamming or a lamp burning out in the projector; thus, there may be no alternate way to display the scene to the jurors without delay. Prints require no mechanical devices to display them, and notations for purposes of identification, documentation, or description are easily affixed on or adjacent to a still photograph.

13.2.7.2 Video Presentation. The use of video to present important information in testimony is an excellent methodology. Key to proper use of video presentation is to ensure that the size of the screen is sufficient to allow all interested parties to see the material adequately. The use of additional monitors may assist in overcoming this problem.

The investigator should be aware of quality issues when preparing the video presentation, as those that will be viewing the presentation are accustomed to broadcast quality video.

13.2.7.3 Computer-Based Presentations. The advancement and increased use of computer-based presentations provides the investigator with an excellent tool for presentation. As with other presentation formats, there are inherent advantages and disadvantages to those programs.

Computer-based presentations provide the user with the ability to put drawings and photographs on the same slide, as well as to provide other highlighting or information that may enhance the observer's ability to understand relationships or information being presented.

The investigator should have backup resources available, such as the original photographs and drawings, in the event that hardware incompatibility or software problems prevent the presentation from being viewed or reduce the effectiveness of the presentation.

13.3 Note Taking. Note taking is a complement to drawings and photographs and should be used primarily to supplement items and to document items that cannot be photographed or drawn. These may include the following:

- (1) Names and addresses
- (2) Model/serial numbers
- (3) Statements
- (4) Photo log
- (5) Identification of items
- (6) Types of materials (e.g., wood paneling, foam plastic, carpet)

Many investigators like to dictate their notes into portable tape recorders. Since people may have difficulty phrasing sentences, it is perfectly acceptable to edit the transcribed version of a tape recording before filing the notes.

The investigator should be careful not to rely solely on tape recorders or any single piece of equipment when documenting critical pieces of information or evidence.

13.4 Drawings. Various types of drawings, including sketches, diagrams, and plans, can be made or obtained to assist the investigator in documenting and analyzing the fire scene.

Depending on the size or complexity of the fire, various techniques can be used to prepare the drawings. The exact detail required in the drawings depends on the decision of the specific investigator. As with photographs, drawings are used to support memory, as the investigator typically gets only one chance to inspect the fire scene.

13.4.1 Fire Investigation Drawings. After selecting the level of detail to which a drawing will be made, the fire investigator needs to decide how to record the damage patterns observed during the investigation. Once again, the detail needed is the decision of the investigator and should be made with the realization that there may be only one chance to document the scene. The detail may be a general approximation or a precise measurement. Supplemented by photographs, drawings of damage patterns provide good documentation of a fire scene and can assist an investigator in reanalyzing a fire scene if previously unknown information becomes available.

13.4.2 Types of Drawings. The investigator may wish to make several types of drawings to assist in analyzing or explaining a fire scene. Figures 13.4.2(a) through 13.4.2(f) are illustrative of drawing documentation.

13.4.3 Selection of Drawings. In selecting the type of drawing to obtain or create, the investigator should ask what construction features, equipment, or other factors were important to the cause, origin, and spread of the fire. For example, if the interior finish of a facility contributed to the fire, then a drawing showing the location of the material is important. If the building caught fire due to an adjoining building burning, then a plan showing the location of the two buildings would be important. If a flammable liquid was used in a fire, it would be important to show where it was used and how it was connected.

FIGURE 13.4.2(a) Site plan showing photo and witness locations.

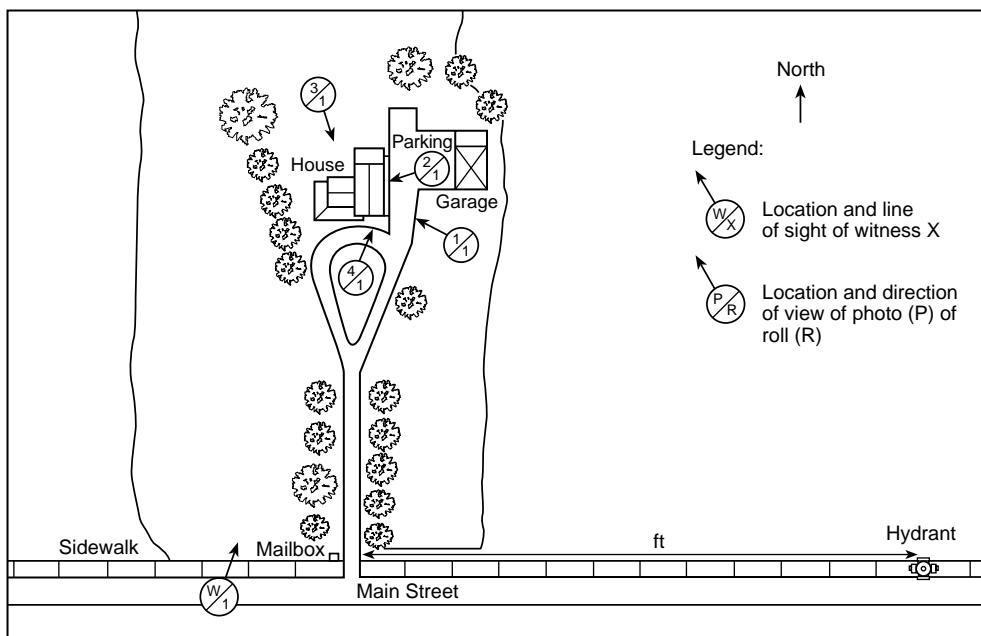

FIGURE 13.4.2(b) Detailed floor plan.

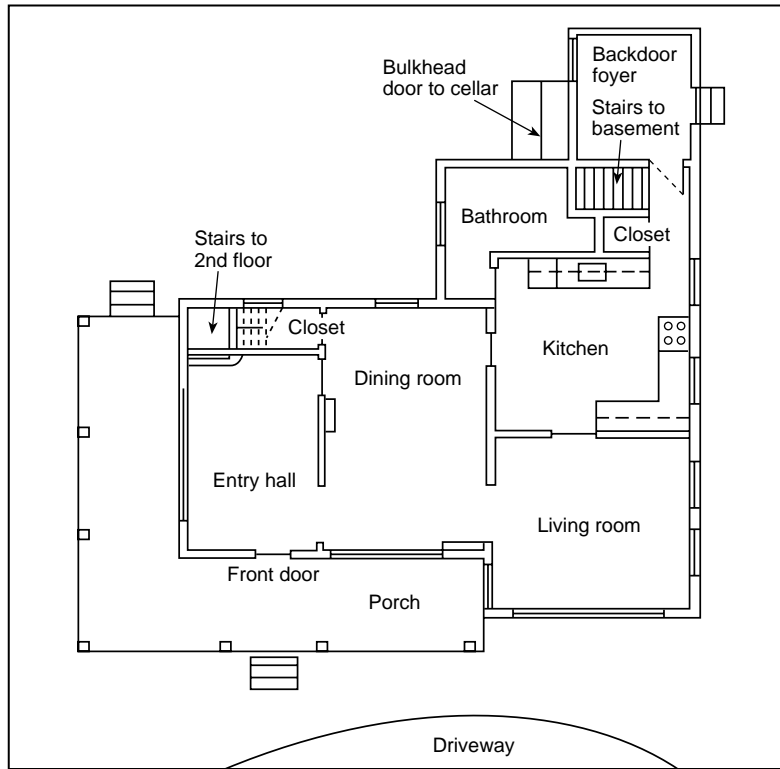

FIGURE 13.4.2(c) Pre-fire contents diagram.

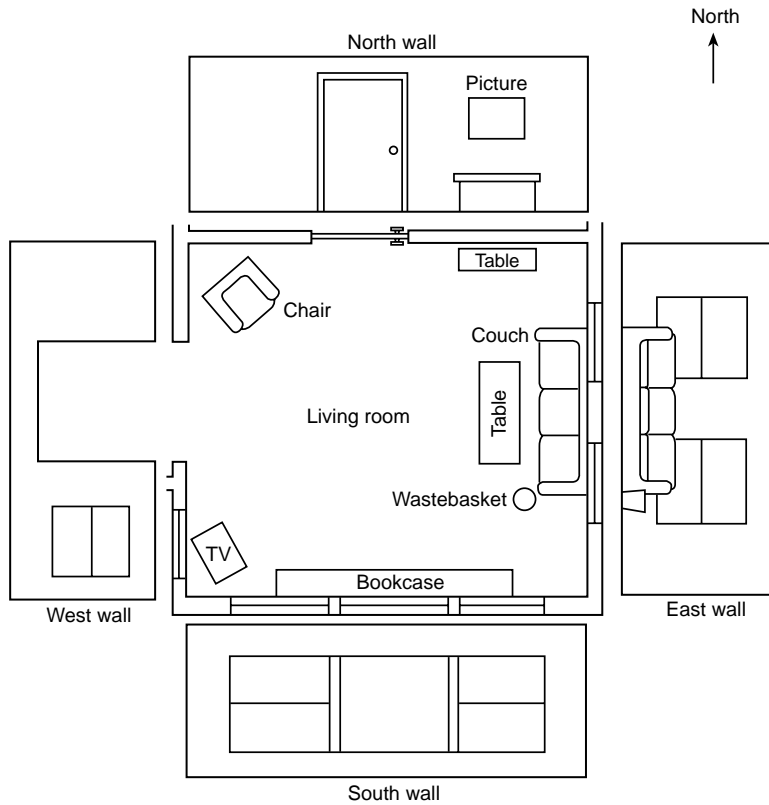
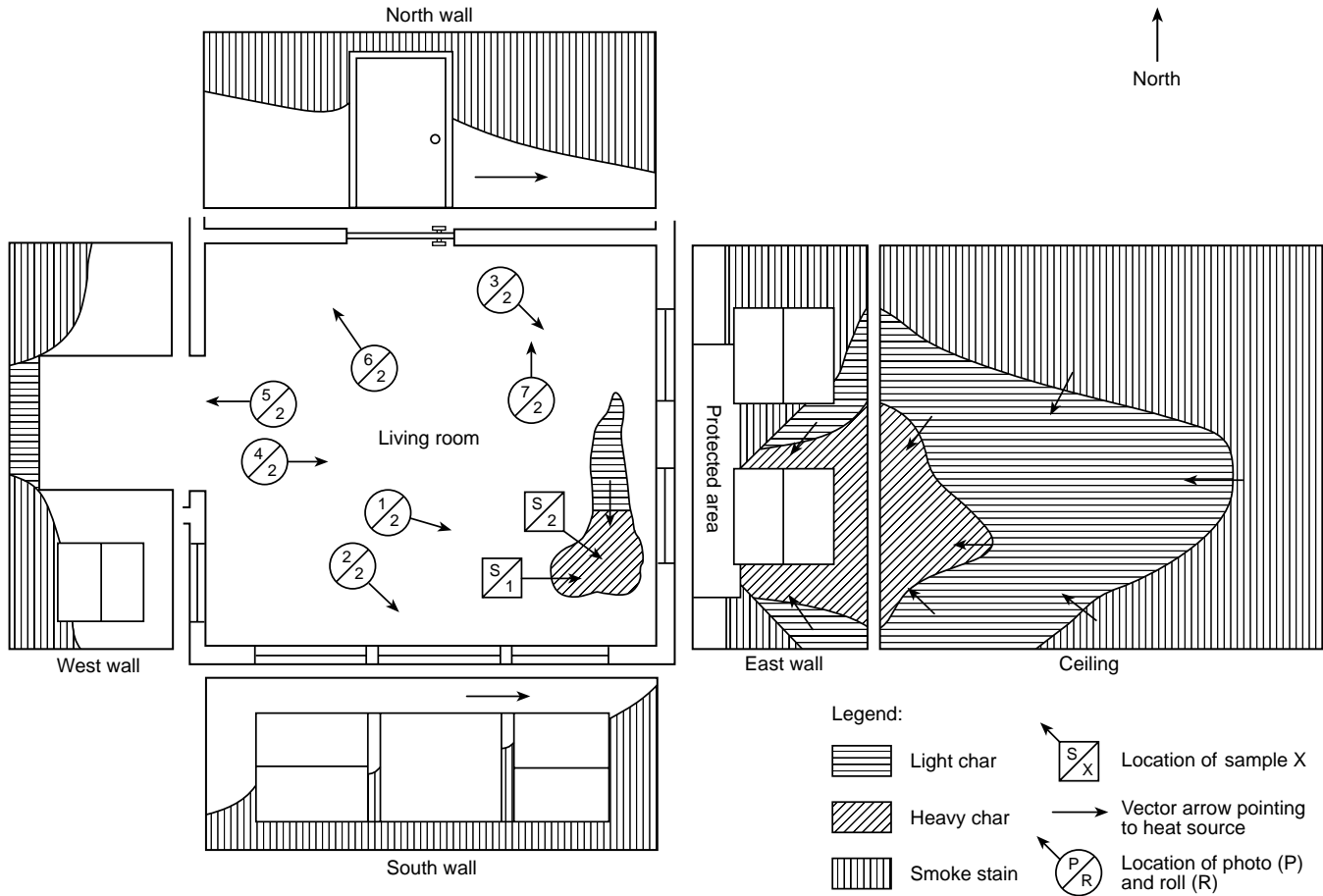

FIGURE 13.4.2(d) Exploded room diagram showing damage patterns, sample locations, and photo locations.



13.4.4* Symbols. The selection of drawing symbols is the investigator's decision. Most importantly, the investigator should be consistent with the symbols used on a fire scene drawing. If an *E* is used to represent an exit sign, it should not also represent an entrance.

13.4.5 Minimum Drawings. In all fire cases the minimum drawing should consist of a simple sketch. A typical building sketch would show the relative locations of rooms, stairs, windows, doors, and associated damage. These drawings can be done freehand with dimensions that are paced off or approximated. This type of drawing, shown in Figure 13.4.5, should suffice on fire cases where the fire analysis and conclusions are simple.

More complex scenes or litigation cases may require developing or acquiring actual building plans and detailed documentation of construction, equipment, furnishings, witnesses, and damage.

13.4.6 Architectural and Engineering Drawings. Many types of drawings are available and, to a student of drawing presentation, there are many references available for additional reading. For the fire investigator trying to document a scene, it is more important to be aware of the general names of drawings and the level of detail on each type of drawing. The architectural and engineering community generally use the following types of drawings in the design and construction process, starting with the least detail.

- (a) *Sketches.* Freehand drawings of concepts
- (b) *Schematic Design Drawings.* Drafted drawings showing the preliminary design layout with little detail
- (c) *Design Development Drawings.* Drafted drawings defining and detailing the schematic drawings
- (d) *Construction Drawings.* Drafted drawings with extensive detail showing what was used by contractors to build the structure
- (e) *As-Built Drawings.* Drafted drawings showing any field modifications to the construction drawings and reflecting the finished structure

Within the design and construction process, there are several types of drawings with which the investigator should be familiar. The most common drawings, along with the discipline that generally prepares them, are shown in Table 13.4.6.

13.5 Architectural and Engineering Schedules. On larger projects, it may be necessary to detail the types of equipment in lists that are called *schedules*. Where many components are specified in great detail, a schedule will usually exist. Typical schedules are as follows:

- (1) Fan schedule
- (2) Door schedule
- (3) Interior finish schedule
- (4) Lighting schedule

FIGURE 13.4.2(e) Contents reconstruction diagram showing damaged furniture in original positions.

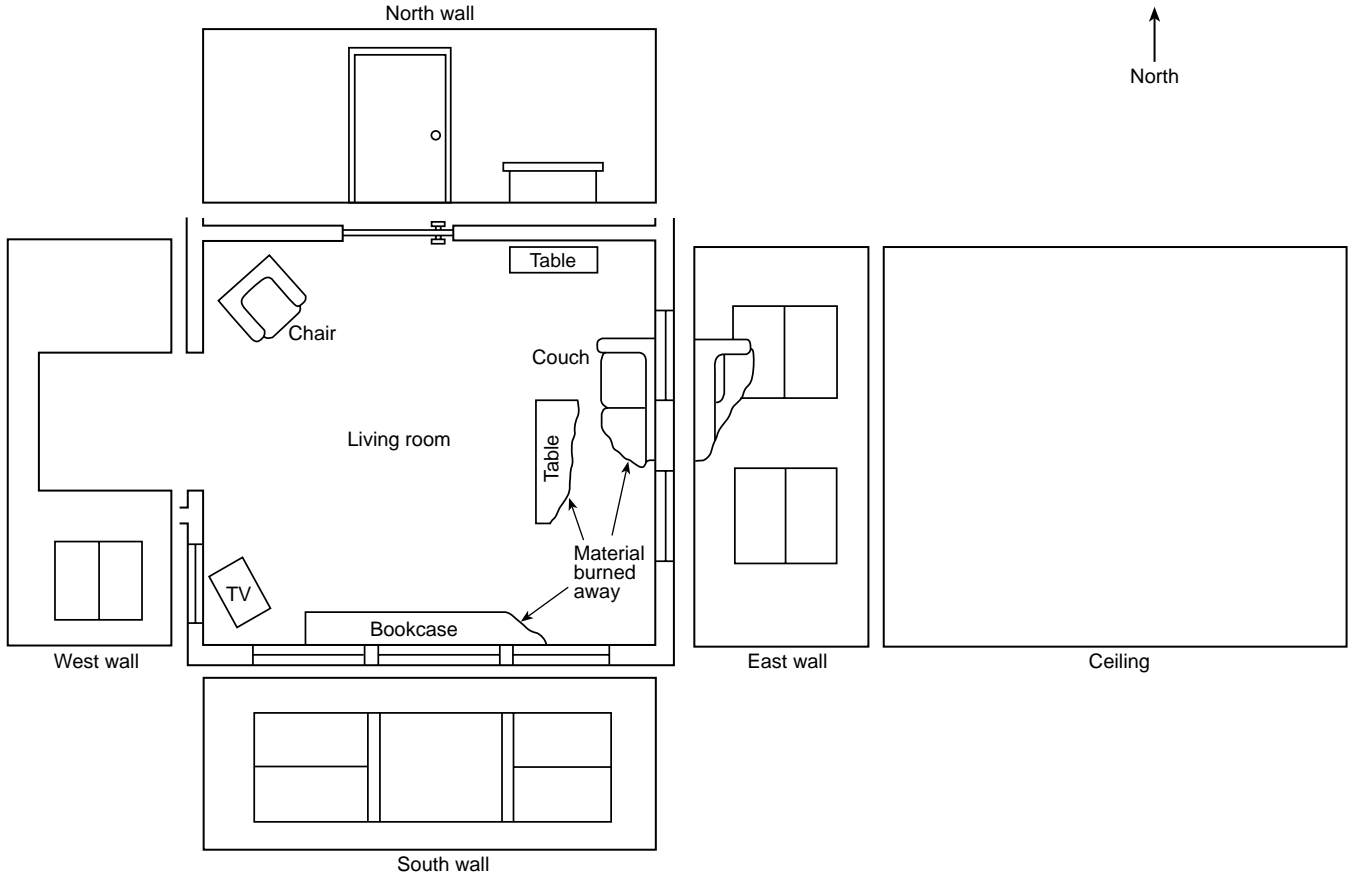
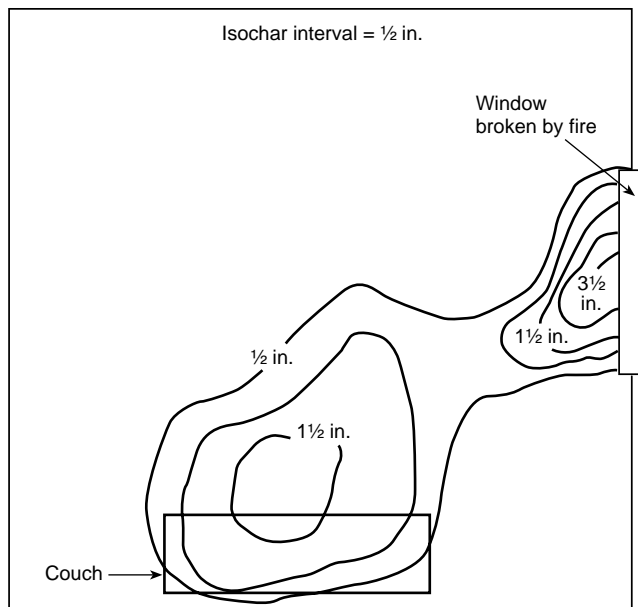

FIGURE 13.4.2(f) An isochar diagram showing lines of equal char depth on exposed ceiling joists.



For SI units, 1 in. = 25.4 mm.

FIGURE 13.4.5 Minimum drawing for simple fire analysis.

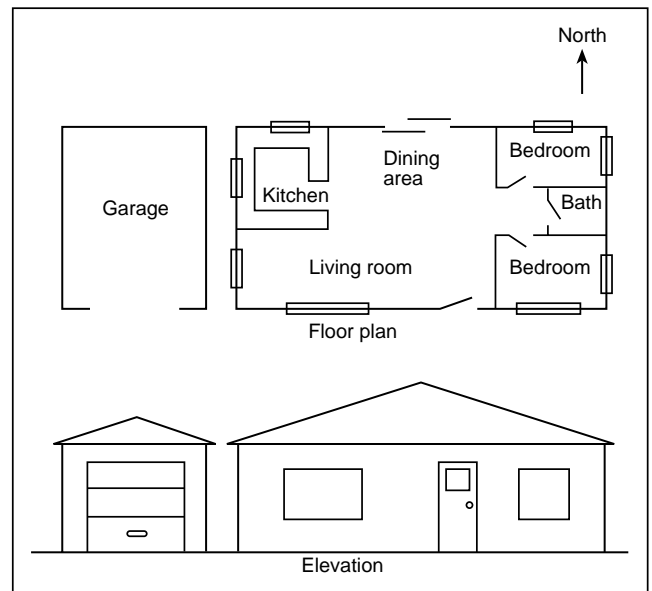

Table 13.4.6 Design and Construction Drawing That May Be Available

Type	Information	Discipline
Topographical	Shows the varying grade of the land	Surveyor
Site plan	Shows the structure on the property with sewer, water, electrical distributions to the structure	Civil engineer
Floor plan	Shows the walls and rooms of structure as if you were looking down on it	Architect
Plumbing	Layout and size of piping for fresh and waste water	Mechanical engineer
Electrical	Size and arrangement of service entrance, switches and outlets, fixed electrical appliances	Electrical engineer
Mechanical	HVAC system	Mechanical engineer
Sprinkler/fire alarm	Self-explanatory	Fire protection engineer
Structural	Frame of building	Structural engineer
Elevations	Shows interior/exterior walls	Architect
Cross section	Shows what the inside of components look like if cut through	Architect
Details	Show close-ups of complex areas	All disciplines

13.6* Specifications. Architects and engineers prepare specifications to accompany their drawings. While the drawings show the geometry of the project, the specifications detail the quality of the materials, responsibilities of various contractors, and the general administration of the project. Specifications are usually divided into sections for the various components of the building. For the fire investigator, the properties of materials can be identified through a specification review and may assist in the analysis.

Chapter 14 Physical Evidence

14.1* General. During the course of any fire investigation, the fire investigator is likely to be responsible for locating, collecting, identifying, storing, examining, and arranging for testing of physical evidence. The fire investigator should be thoroughly familiar with the recommended and accepted methods of processing such physical evidence.

14.2 Physical Evidence. Physical evidence, defined generally, is any physical or tangible item that tends to prove or disprove a particular fact or issue. Physical evidence at the fire scene may be relevant to the issues of the origin, cause, spread, or the responsibility for the fire.

The decision on what physical evidence to collect at the incident scene for submission to a laboratory or other testing facility for examination and testing, or for support of a fact or opinion, rests with the fire investigator. This decision may be based on a variety of considerations, such as the scope of the investigation, legal requirements, or prohibition. (See Section 9.2.) Additional evidence may also be collected by others, including other investigators, insurance company representatives, manufacturer's representatives, owners, and occupants. The investigator should also be aware of issues related to spoliation of evidence.

14.3* Preservation of the Fire Scene and Physical Evidence. Every attempt should be made to protect and preserve the fire scene as intact and undisturbed as possible, with the structure, contents, fixtures, and furnishings remaining in their pre-fire locations. (See Figure 14.3.)

FIGURE 14.3 Physical evidence at a fire scene. Evidence such as this small paper match could easily be destroyed or lost in an improperly preserved fire scene.



Generally, the cause of a fire or explosion is not known until near the end of the investigation. Therefore, the evidentiary or interpretative value of various pieces of physical evidence observed at the scene may not be known until, at, or near the end of the fire scene examination, or until the end of the complete investigation. As a result, the entire fire scene should be considered physical evidence and should be protected and preserved.

The responsibility for the preservation of the fire scene and physical evidence does not lie solely with the fire investigator, but should begin with arriving fire-fighting units or police authorities. Lack of preservation may result in the destruction, contamination, loss, or unnecessary movement of physical evidence. Initially, the incident commander and, later, the fire investigator should secure or ensure the security of the fire scene from unnecessary and unauthorized intrusions and should limit fire suppression activities to those that are necessary.

Evidence at the fire scene should be considered not only in a criminal context, such as in traditional forensic evidence (e.g., weapons, bodily fluids, footprints), nor should it be lim-

ited to arson-related evidence, items, or artifacts, such as incendiary devices or containers. Potential evidence at the fire scene and surrounding areas can include the physical structure, the contents, the artifacts, and any materials ignited or any material on which fire patterns appear.

14.3.1 Fire Patterns as Physical Evidence. The evidentiary and interpretative use of fire patterns may be valuable in the identification of a potential ignition source, such as an incendiary device in an arson fire or an appliance in an accidental fire. Fire patterns are the visible or measurable physical effects that remain after a fire. These include thermal effects on materials, such as charring, oxidation, consumption of combustibles, smoke and soot deposits, distortion, melting, color changes, changes in the character of materials, structural collapse, and other effects. (See Section 4.3.)

14.3.2 Artifact Evidence. Artifacts can be the remains of the material first ignited, the ignition source, or other items or components in some way related to the fire ignition, development, or spread. An artifact may also be an item on which fire patterns are present, in which case the preservation of the artifact is not for the item itself but for the fire pattern that is contained thereon.

14.3.3 Protecting Evidence. There are a number of methods that can be utilized to protect evidence from destruction. Some methods include posting a fire fighter or police officer as a sentry to prevent or limit access to a building, a room, or an area; use of traffic cones or numerical markers to identify evidence or areas that warrant further examination; covering the area or evidence with tarpaulins prior to overhaul; or isolating the room or area with rope, caution tape, or police line tape. The investigator may benefit from supervising overhaul and salvage operations.

Items found at the fire scene, such as empty boxes or buckets, may be placed over an artifact. However, these items may not clearly identify the artifact as evidence that should be preserved by fire fighters or others at the fire scene. If evidence is not clearly identified, it may be susceptible to movement or destruction at the scene.

14.3.4 Role and Responsibilities of Fire Suppression Personnel in Preserving the Fire Scene. Generally, fire officers and fire fighters have been instructed during basic fire training that they have a responsibility on the fire scene regarding fire investigation. In most cases, this responsibility is identified as recognizing the indicators of incendiarism, such as multiple fires, the presence of incendiary devices or trailers, and the presence of ignitable liquids at the area of origin (see Chapter 19). While this is an important aspect of their responsibilities in the investigation of the fire cause, it is only a small part.

Prompt control and extinguishment of the fire protects evidence. The ability to preserve the fire scene is often an important element in the investigation. Even when fire officers and fire fighters are not responsible for actually determining the origin or cause of the fire, they play an integral part in the investigation by preserving the fire scene and physical evidence.

14.3.4.1 Preservation. Once an artifact or other evidence has been discovered, preliminary steps should be taken to preserve and protect the item from loss, destruction, or movement. The person making the discovery should notify the incident commander as soon as practical. The incident commander should notify the fire investigator or other appropri-

ate individual or agency with the authority and responsibility for the documentation and collection of the evidence.

14.3.4.2 Caution in Fire Suppression Operations. Fire crews should avoid causing unnecessary damage to evidence when using straight-stream hoselines, pulling ceilings, breaking windows, collapsing walls, and performing overhaul and salvage.

14.3.4.2.1 Use of Water Lines and Hose Streams. When possible, fire fighters should use caution with straight-stream applications, particularly at the base of the fire, because the base of the fire may be the area of origin. Evidence of the ignition source can sometimes be found at the area of origin. The use of hoselines, particularly straight-stream applications, can move, damage, or destroy physical evidence that may be present.

The use of water hoselines for overhaul operations like washing down, or for opening up walls or ceilings, should also be restricted to areas away from possible areas of origin.

The use of water should be controlled in areas where the investigator may wish to look at the floor for possible fire patterns. When draining the floor of standing water, the drain hole should be located so as to have the least impact on the fire scene and fire patterns.

14.3.4.2.2 Overhaul. It is during overhaul that any remaining evidence not damaged by the fire is susceptible to being destroyed or displaced. Excessive overhaul of the fire scene prior to the documentation and analysis of fire patterns can affect the investigation, including failure to determine the area of origin.

While the fire fighters have a responsibility to control and extinguish the fire and then check for fire extension, they are also responsible for the preservation of evidence. These two responsibilities may appear to be in conflict and, as a result, it is usually the evidence that is affected during the search for hidden fire. However, if overhaul operations are performed in a systematic manner, both responsibilities can be met successfully.

14.3.4.2.3 Salvage. The movement or removal of artifacts from a fire scene can make the reconstruction difficult for the investigator. If the investigator cannot determine the pre-fire location of the evidence, the analytical or interpretative value of the evidence may be lost. Moving, and particularly removing, contents and furnishings or other evidences at the fire scene should be avoided until the documentation, reconstruction, and analysis is completed.

14.3.4.2.4 Movement of Knobs and Switches. Fire fighters should refrain from turning knobs and operating switches on any equipment, appliances, or utility services at the fire scene. The position of components, such as the knobs and switches, may be a necessary element in the investigation, particularly in developing fire ignition scenarios or hypotheses. These components, which are often constructed of plastics, can become very brittle when subjected to heating. Their movement may alter the original post-fire state and may cause the switch to break or to become impossible to relocate in its original post-fire position. (See 21.5.3.)

14.3.4.2.5 Use of Power Tools. The use of gasoline- or diesel-powered tools and equipment should be controlled carefully in certain locations. The refueling of any fuel-powered equipment or tools should be done outside the perimeter of the fire scene. Whenever fuel-powered equipment is used on the fire scene, its use and location should be documented and the investigator advised.

14.3.4.2.6 Limiting Access of Fire Fighters and Other Emergency Personnel. Access to the fire scene should be limited to those persons who need to be there. This precaution includes limiting fire fighters and other emergency or rescue personnel to those necessary for the task at hand. When possible, the activity or operation should be postponed until the evidence has been documented, protected, evaluated, and collected.

14.3.5 Role and Responsibilities of the Fire Investigator. If the fire fighters have not taken the preliminary steps to preserve or protect the fire scene, then the fire investigator should assume the responsibility for doing so. Then, depending on the individual's authority and responsibility, the investigator should document, analyze, and collect the evidence.

14.3.6 Practical Considerations. The precautions in this section should not be interpreted as requiring the unsafe or infinite preservation of the fire scene. It may be necessary to repair or demolish the scene for safety or for other practical reasons. Once the scene has been documented by interested parties and the relevant evidence removed, there is no reason to continue to preserve the scene. The decision as to when sufficient steps have been taken to allow the resumption of normal activities should be made by all interested parties known at that time.

14.4 Contamination of Physical Evidence. Contamination of physical evidence can occur from improper methods of collection, storage, or shipment. Like improper preservation of the fire scene, any contamination of physical evidence may reduce the evidentiary value of the physical evidence.

14.4.1 Contamination of Evidence Containers. Unless care is taken, physical evidence may become contaminated through the use of contaminated evidence containers. For this reason, the fire investigator should take every reasonable precaution to ensure that new and uncontaminated evidence containers are stored separately from used containers or contaminated areas.

One practice that may help to limit a possible source of cross contamination of evidence collection containers, including steel paint cans or glass jars, is to seal them immediately after receipt from the supplier. The containers should remain sealed during storage and transportation to the evidence collection site. An evidence collection container should be opened only to receive evidence at the collection point, at which time it should be resealed pending laboratory examination.

14.4.2* Contamination During Collection. Most contamination of physical evidence occurs during its collection. This is especially true during the collection of liquid and solid accelerant evidence. The liquid and solid accelerant may be absorbed by the fire investigator's gloves or may be transferred onto the collection tools and instruments.

Avoiding cross-contamination of any subsequent physical evidence, therefore, becomes critical to the fire investigator. To prevent such cross-contamination, the fire investigator can wear disposable plastic gloves or place his or her hands into plastic bags during the collection of the liquid or solid accelerant evidence. New gloves or bags should always be used during the collection of each subsequent item of liquid or solid accelerant evidence.

An alternative method to limit contamination during collection is to utilize the evidence container itself as the collection tool. For example, the lid of a metal can may be used to scoop the physical evidence into the can, thereby eliminating

any cross-contamination from the fire investigator's hands, gloves, or tools.

Similarly, any collection tools or overhaul equipment such as brooms, shovels, or squeegees utilized by the fire investigator need to be cleaned thoroughly between the collection of each item of liquid or solid accelerant evidence to prevent similar cross-contamination. The fire investigator should be careful, however, not to use waterless or other types of cleaners that may contain volatile solvents.

14.4.3 Contamination by Fire Fighters. Contamination is possible when fire fighters are using or refilling fuel-powered tools and equipment in an area where an investigator later tests for the presence or omission of an ignitable liquid. Fire fighters should take the necessary precautions to ensure that the possibility of contamination is kept to a minimum, and the investigator should be informed when the possibility of contamination exists.

14.5 Methods of Collection. The collection of physical evidence is an integral part of a properly conducted fire investigation. The method of collection of the physical evidence is determined by many factors including the following.

- (a) *Physical State.* Whether the physical evidence is a solid, liquid, or gas
- (b) *Physical Characteristics.* The size, shape, and weight of the physical evidence
- (c) *Fragility.* How easily the physical evidence may be broken, damaged, or altered
- (d) *Volatility.* How easily the physical evidence may evaporate

Regardless of which method of collection is employed, the fire investigator should be guided by the policies and procedures of the laboratory that will examine or test the physical evidence.

14.5.1* Documenting the Collection of Physical Evidence. Physical evidence should be thoroughly documented before it is moved. This documentation can be best accomplished through field notes, written reports, sketches, and diagrams, with accurate measurements and photography. The diagramming and photography should always be accomplished before the physical evidence is moved or disturbed. The investigator should strive to maintain a list of all evidence removed and of who removed it.

The purpose of such documentation is twofold. First, the documentation should assist the fire investigator in establishing the origin of the physical evidence, including not only its location at the time of discovery, but also its condition and relationship to the fire investigation. Second, the documentation should also assist the fire investigator in establishing that the physical evidence has not been contaminated or altered.

14.5.2 Collection of Traditional Forensic Physical Evidence. Traditional forensic physical evidence includes, but is not limited to, finger and palm prints, bodily fluids such as blood and saliva, hair and fibers, footwear impressions, tool marks, soils and sand, woods and sawdust, glass, paint, metals, handwriting, questioned documents, and general types of trace evidence. Although usually associated with other types of investigations, these types of physical evidence may also become part of a fire investigation. The recommended methods of collection of such traditional forensic physical evidence vary greatly. As such, the fire investigator should consult with the forensic laboratory that will examine or test the physical evidence.

14.5.3 Collection of Evidence for Accelerant Testing. An accelerant is any agent, often an ignitable liquid, used to initiate or speed the spread of fire. Accelerant may be found in any state: gas, liquid, or solid. Evidence for accelerant testing should be collected and tested in accordance with ASTM E 1387, *Standard Test Method for Ignitable Liquid Residues in Extracts from Fire Debris Samples by Gas Chromatography*, or with ASTM E 1618, *Standard Test Method for Ignitable Liquid Residues in Extracts from Fire Debris by Gas Chromatography–Mass Spectrometry*.

Liquid accelerants have unique characteristics that are directly related to their collection as physical evidence. These characteristics include the following:

- (1) Liquid accelerants are readily absorbed by most structural components, interior furnishings, and other fire debris.
- (2) Generally, liquid accelerants float when in contact with water (alcohol is a noted exception).
- (3) Liquid accelerants have remarkable persistence (survivability) when trapped within porous material.

When a canine/handler team is used to detect possible evidence of accelerant use, the handler should be allowed to decide what areas (if any) of a building or site to examine. Prior to any search, the handler should carefully evaluate the site for safety and health risks such as collapse, falling, toxic materials, residual heat, and vapors and should be the final arbiter of whether the canine is allowed to search. It should also be the handler's decision whether to search all of a building or site, even areas not involved in the fire.

The canine/handler team can assist with the examination of debris (loose or packaged) removed from the immediate scene as a screening step to confirm whether the appropriate debris has been recovered for laboratory analysis.

14.5.3.1 Collection of Liquid Samples for Accelerant Testing. When a possible liquid accelerant is found in a liquid state, it can easily be collected using any one of a variety of methods. Whichever method is employed, however, the fire investigator should be certain that the evidence does not become contaminated.

If readily accessible, the liquid accelerant may be collected with a new syringe, eye dropper, pipette, siphoning device, or the evidence container itself. Sterile cotton balls or gauze pads may also be used to absorb the liquid. This method of collection results in the liquid accelerant's becoming absorbed by the cotton balls or gauze pads. The cotton balls or gauze pads and their absorbed contents then become the physical evidence that should be sealed in an airtight container and submitted to the laboratory for examination and testing.

14.5.3.2 Collection of Liquid Evidence Absorbed by Solid Materials. Often, liquid accelerant evidence may be found only where the liquid accelerant has been absorbed by solid materials, including soils and sands. This method of collection merely involves the collection of these solid materials with their absorbed contents. The collection of these solid materials may be accomplished by scooping them with the evidence container itself or by cutting, sawing, or scraping. Raw, unsealed, or sawed edges, ends, nail holes, cracks, knot holes, and other similar areas of wood, plaster, sheet rock, mortar, or even concrete are particularly good areas to sample. If deep penetration is suspected, the entire cross section of material should be removed and preserved for laboratory evaluation. In some solid material, such as soil or sand, the liquid accelerant may

absorb deeply into the material. The investigator should therefore remove samples from a greater depth.

In those situations where liquid accelerants are believed to have become trapped in porous material, such as a concrete floor, the fire investigator may use absorbent materials such as lime, diatomaceous earth, or non-self-rising flour. This method of collection involves spreading the absorbent onto the concrete surface, allowing it to stand for 20 to 30 minutes, and securing it in a clean, airtight container. The absorbent is then extracted in the laboratory. The investigator should be careful to use clean tools and containers for the recovery step since the absorbent is easily contaminated. A sample of the unused absorbent should be preserved separately for analysis as a comparison sample.

14.5.3.3 Collection of Solid Samples for Accelerant Testing. Solid accelerant may be common household materials and compounds or dangerous chemicals. Since some incendiary materials remain corrosive or reactive, care should be taken in packaging to ensure that the corrosive residues do not attack the packaging container. In addition, such materials should be handled carefully by personnel for their own safety.

14.5.3.4* Comparison Samples. When physical evidence is collected for examination and testing, it is often necessary to also collect comparison samples.

The collection of comparison samples is especially important in the collection of materials that are believed to contain liquid or solid accelerant. For example, the comparison sample for physical evidence consisting of a piece of carpeting believed to contain a liquid accelerant would be a piece of the same carpeting that does not contain any of the liquid accelerant. Comparison samples allow the laboratory to evaluate the possible contributions of volatile pyrolysis products to the analysis and also to estimate the flammability properties of the normal fuel present.

It is recognized that comparison samples may be unavailable due to the condition of the fire scene. It is also recognized that comparison samples are frequently unnecessary for the valid identification of ignitable liquid residue. The determination of whether comparison samples are necessary is made by the laboratory analyst, but because it is usually impossible for an investigator to return to a scene to collect comparison samples, they should be collected at the time of the initial investigation.

If mechanical or electrical equipment is suspected in the fire ignition, exemplar equipment may be identified and collected or purchased as a comparison sample.

14.5.3.5* Canine Teams. Properly trained and validated ignitable liquid detection canine/handler teams have proven their ability to improve fire investigations by assisting in the location and collection of samples for laboratory analysis for the presence of ignitable liquids. The proper use of detection canines is to assist with the location and selection of samples.

In order for the presence or absence of an ignitable liquid to be scientifically confirmed in a sample, that sample should be analyzed by a laboratory in accordance with 14.5.3. Any canine alert not confirmed by laboratory analysis should not be considered validated.

Research has shown that canines have responded or have been alerted to pyrolysis products that are not produced by an ignitable liquid and have not always responded when an ignitable liquid accelerant was known to be present. If an investigator feels that there are indicators of an accelerant, samples should be taken even in the absence of a canine alert.

The canine olfactory system is believed capable of detecting gasoline at concentrations below those normally cited for laboratory methods. The detection limit, however, is not the sole criterion or even the most important criterion for any forensic technique. Specificity, the ability to distinguish between ignitable liquids and background materials, is even more important than sensitivity for detection of any ignitable liquid residues. Unlike explosive- or drug-detecting dogs, these canines are trained to detect substances that are common to our everyday environment. The techniques exist today for forensic laboratories to detect submicroliter quantities of ignitable liquids, but because these substances are intrinsic to our mechanized world, merely detecting such quantities is of limited evidential value.

Current research does not indicate which individual chemical compounds or classes of chemical compounds are the key “triggers” for canine alerts. Research reveals that most classes of compounds contained in ignitable liquids may be produced from the burning of common synthetic materials. Laboratories that use ASTM guidelines (see *Section 14.10*) have minimum standards that define those chemical compounds that must be present in order to make a positive determination. The sheer variety of pyrolysis products present in fire scenes suggests possible reasons for some unconfirmed alerts by canines. The discriminatory ability of the canine to distinguish between pyrolysis products and ignitable liquids is remarkable but not infallible.

The proper objective of the use of canine/handler teams is to assist with the selection of samples that have a higher probability of laboratory confirmation than samples selected without the canine’s assistance.

Canine ignitable liquid detection should be used in conjunction with, and not in place of, the other fire investigation and analysis methods described in this guide.

14.5.4 Collection of Gaseous Samples. During certain types of fire and explosion investigations, especially those involving fuel gases, it may become necessary for the fire investigator to collect a gaseous sample. The collection of gaseous samples may be accomplished by several methods, one of which is shown in Figure 14.5.4.

FIGURE 14.5.4 Gathering a gaseous sample.



The first method involves the use of commercially available mechanical sampling devices. These devices merely draw a sample of the gaseous atmosphere and contain it in a sample chamber or draw it through a trap of charcoal- or polymer-adsorbing material for later analysis.

Another method is the utilization of evacuated air-sampling cans. These cans are specifically designed for taking gaseous samples.

14.5.5 Collection of Electrical Equipment and Components.

Before attempting to collect electrical equipment or components, the fire investigator should verify that all sources of electricity are off or disconnected. All safety procedures described in Chapter 10 should be followed. Electrical equipment and components may be collected as physical evidence to assist the fire investigator in determining whether the component was related to the cause of the fire.

Electrical components, after being involved in a fire, may become brittle and subject to damage if mishandled. Therefore, methods and procedures used in collection should preserve, as far as practical, the condition in which the physical evidence was found. Before any electrical component is collected as physical evidence, it should be thoroughly documented, including being photographed and diagrammed. Electrical wiring can usually be cut easily and removed. This type of evidence may consist of a short piece, a severed or melted end, or it might be a much longer piece, including an unburned section where the wiring’s insulation is still intact. The fire investigator should collect the longest section of wiring practicable so that any remaining insulation can also be examined. Before wires are cut, a photograph should be taken of the wire(s), and then both ends of the wire should be tagged and cut so that they can be identified as one of the following:

- (1) The device or appliance to which it was attached or from which it was severed
- (2) The circuit breaker or fuse number or location to which the wire was attached or from which it was severed
- (3) The wire’s path or the route it took between the device and the circuit protector

Electrical switches, receptacles, thermostats, relays, junction boxes, electrical distribution panels, and similar equipment and components are often collected as physical evidence. It is recommended that these types of electrical evidence be removed intact, in the condition in which they were found.

When practical, it is recommended that any fixtures housing such equipment and components be removed without disturbing the components within them. Electrical distribution panels, for example, should be removed intact. An alternative method, however, would be the removal of individual fuse holders or circuit breakers from the panel. If the removal of individual components becomes necessary, the fire investigator should be careful not to operate or manipulate them while being careful to document their position and their function in the overall electrical distribution system.

If the investigator is unfamiliar with the equipment, he or she should obtain assistance from someone knowledgeable regarding the equipment, prior to disassembly or on-scene testing, to prevent damage to the equipment or components.

14.5.6 Collection of Appliances or Small Electrical Equipment.

Whenever an appliance or other type of equipment is believed to be part of the ignition scenario, it is recommended that the fire investigator have it examined or tested. Appliances may be collected as physical evidence to support the fire

investigator's determination that the appliance was or was not the cause of the fire. This type of physical evidence may include many diverse items, from the large (e.g., furnaces, water heaters, stoves, washers, dryers) to the small (e.g., toasters, coffee pots, radios, irons, lamps).

Where practical, the entire appliance or item of equipment should be collected as physical evidence. This includes any electrical power cords or fuel lines supplying or controlling it.

Where the size or damaged condition of an appliance or item of equipment makes it impractical to be removed in its entirety, it is recommended that it be secured in place for examination and testing. Often, however, only a single component or group of components in an appliance or item of equipment may be collected as physical evidence. In that case, the fire investigator should strive to ensure that the removal, transportation, and storage of such evidence maintains the physical evidence in its originally discovered condition.

14.6 Evidence Containers. Once collected, physical evidence should be placed and stored in an appropriate evidence container. Like the collection of the physical evidence itself, the selection of an appropriate evidence container also depends on the physical state, physical characteristics, fragility, and volatility of the physical evidence. The evidence container should preserve the integrity of the evidence and should prevent any change to or contamination of the evidence.

Evidence containers may be common items, such as envelopes, paper bags, plastic bags, glass containers, or metal cans, or they may be containers specifically designed for certain types of physical evidence. The investigator's selection of an appropriate evidence container should be guided by the policies and procedures of the laboratory that will examine or test the physical evidence or the use to which the evidence will be subjected.

14.6.1 Liquid and Solid Accelerant Evidence Containers. It is recommended that containers used for the collection of liquid and solid accelerant evidence be limited to four types. These include metal cans, glass jars, special evidence bags, and common plastic evidence bags.

The fire investigator should be concerned with preventing the evaporation of the accelerant and preventing its contamination. It is important, therefore, that the container used be completely sealed to prohibit such evaporation or contamination.

14.6.1.1 Metal Cans. The recommended container for the collection of liquid and solid accelerant evidence is an unused, clean metal can, as shown in Figure 14.6.1.1. In order to allow space for vapors to collect, the can should be not more than two-thirds full.

The advantages of using metal cans include their availability, economic price, durability, and ability to prevent the evaporation of volatile liquids.

The disadvantages, however, include the inability to view the evidence without opening the container, the space requirements for storage, and the tendency of the container to rust when stored for long periods of time. If metal cans are used to store bulk quantities of volatile liquids, such as gasoline, high storage temperatures [above 100°F (38°C)] can produce sufficient vapor pressure to force the lid open and cause loss of sample. For such samples, glass jars may be more appropriate.

FIGURE 14.6.1.1 Various types of metal cans.



14.6.1.2 Glass Jars. Glass jars can also be used for the collection of liquid and solid accelerant evidence. It is important that the jars not have glued cap liners or rubber seals, especially when bulk liquids are collected. The glue often contains traces of solvent that can contaminate the sample, and rubber seals can soften or even dissolve in the presence of liquid accelerants or their vapors, allowing leakage or loss of the sample. In order to allow space for vapor samples to be taken during examination and testing, the glass jar should be not more than two-thirds full.

The advantages of using glass jars include their availability, their low price, the ability to view the evidence without opening the jar, the ability to prevent the evaporation of volatile liquids, and their lack of deterioration when stored for long periods of time.

The disadvantages, however, include their tendency to break easily and their physical size, which often prohibits the storage of large quantities of physical evidence.

14.6.1.3 Special Evidence Bags. Special bags, designed specifically for liquid and solid accelerant evidence, can also be used for collection. Unlike common plastic evidence bags, these special evidence bags do not have a chemical composition that can cause erroneous test results during laboratory examination and during testing of the physical evidence contained in such bags.

The advantages of using special evidence bags include their availability in a variety of shapes and sizes, their economic price, the ability to view the evidence without opening the bag, their ease of storage, and the ability to prevent the evaporation of volatile liquids.

The disadvantages, however, are that they are susceptible to being damaged easily, resulting in the contamination of the physical evidence contained in them, and they may be difficult to seal adequately.

14.6.1.4 Common Plastic Bags. While they are not generally usable for volatile evidence, common (polyethylene) plastic bags can be used for some evidence packaging. They can be used for packaging incendiary devices or solid accelerant residues, but they could be permeable, allowing for loss and contamination.

The advantages of using common plastic bags include their availability in a variety of shapes and sizes, their economic price, the ability to view the evidence without opening the bag, and their ease of storage.

The disadvantages, however, are their susceptibility to easy damage (tearing and penetration), resulting in the contamination of the physical evidence contained in them, and their marked inability to retain light hydrocarbons and alcohols, resulting in loss of the sample, misidentification, or cross-contamination between containers in the same box.

14.7 Identification of Physical Evidence. All evidence should be marked or labeled for identification at the time of collection.

Recommended identification includes the name of the fire investigator collecting the physical evidence, the date and time of collection, an identification name or number, the case number and item designation, a description of the physical evidence, and where the physical evidence was located. This can be accomplished directly on the container (see Figure 14.7) or on a preprinted tag or label that is then securely fastened to the container.

FIGURE 14.7 Marking of the evidence container.



The fire investigator should be careful that the identification of the physical evidence cannot be easily damaged, lost, removed, or altered. The fire investigator also should be careful that the placement of the identification, especially adhesive labels, does not interfere with subsequent examination or testing of the physical evidence at the laboratory.

14.8 Transportation and Storage of Physical Evidence. Transportation of physical evidence to the laboratory or testing facility can be done either by hand delivery or by shipment.

14.8.1 Hand Delivery. Whenever possible, it is recommended that physical evidence be hand delivered for examination and testing. Hand delivery minimizes the potential of the physical evidence becoming damaged, misplaced, or stolen.

During such hand delivery, the fire investigator should take every precaution to preserve the integrity of the physical evidence. It is recommended that the physical evidence remain in the immediate possession and control of the fire investigator until arrival and transfer of custody at the laboratory or testing facility.

The fire investigator should define the scope of the examination or testing desired in writing. This request should

include the name, address, and telephone number of the fire investigator; a detailed listing of the physical evidence being submitted for examination and testing; and any other information required, dependent on the nature and scope of the examination and testing requested. This request may also include the facts and circumstances of the incident yielding the physical evidence.

14.8.2 Shipment. It may sometimes become necessary to ship physical evidence to a laboratory or testing facility for examination and testing. When shipping becomes necessary, the fire investigator should take every precaution to preserve the integrity of that physical evidence.

The fire investigator should choose a container of sufficient size to adequately hold all of the individual evidence containers from a single investigation. Physical evidence from more than one investigation should never be placed in the same shipment.

The individual evidence container should be packaged securely within the shipping container. A letter of transmittal should be included. The letter of transmittal is a written request for laboratory examination and testing. It should include the name, address, and telephone number of the fire investigator; a detailed listing of the physical evidence being submitted for examination and testing; the nature and scope of the examination and testing desired; and any other information required, depending on the nature and scope of the examination and testing requested. This letter of transmittal may also include the facts and circumstances of the incident yielding the physical evidence.

The sealed package should be shipped by registered United States mail or any commercial courier service. The fire investigator should, however, always request return receipts and signature surveillance.

14.8.2.1 Shipping Electrical Evidence. In addition to the procedures described in 14.8.2, the investigator should be aware that some electrical equipment components with sensitive electromechanical components may not be suitable for shipment. Examples include certain circuit breakers, relays, or thermostats. The fire investigator should consult personnel at laboratory or testing facilities for advice on how to transport the evidence.

14.8.2.2 Volatile or Hazardous Materials. The fire investigator is cautioned about shipping volatile or hazardous materials. The investigator should ensure that such shipments are made in accordance with applicable federal, state, and local law. When dealing with volatile evidence, it is important that the evidence be protected from extremes of temperature. Freezing or heating of the volatile materials may affect lab test results. Generally, the lower the temperature at which the evidence is stored, the better the volatile sample will be preserved, but it should not be allowed to freeze.

14.8.3 Storage of Evidence. Physical evidence should be maintained in the best possible condition until it is no longer needed. It should always be protected from loss, contamination, and degradation. Heat, sunlight, and moisture are the chief sources of degradation of most kinds of evidence. Dry and dark conditions are preferred, and the cooler the better. Refrigeration of volatile evidence is strongly recommended. If a sample is being collected for fire-debris analysis, it may be frozen, since freezing will prevent microbial and other biological degradation. However, freezing may interfere with flash point or other physical tests and may burst water-filled containers.

14.9 Chain of Custody of Physical Evidence. The value of physical evidence entirely depends on the fire investigator's efforts to maintain the security and integrity of that physical evidence from the time of its initial discovery and collection to its subsequent examination and testing. At all times after its discovery and collection, physical evidence should be stored in a secured location that is designed and designated for this purpose. Access to this storage location should be limited in order to limit the chain of custody to as few persons as possible. Wherever possible, the desired storage location is one that is under the sole control of the fire investigator.

When it is necessary to pass chain of custody from one person to another, it should be done using a form on which the receiving person signs for the physical evidence. Figure 14.9 shows an example of such a form.

FIGURE 14.9 Chain of custody form.

Crime Scene Search Evidence Report	
Name of subject _____	
Offense _____	
Date of incident _____ Time _____ a.m. p.m.	
Search officer _____	
Evidence description _____	

Location _____	

Chain of Possession	
Received from _____	
By _____	
Date _____ Time _____ a.m. p.m.	
Received from _____	
By _____	
Date _____ Time _____ a.m. p.m.	
Received from _____	
By _____	
Date _____ Time _____ a.m. p.m.	
Received from _____	
By _____	
Date _____ Time _____ a.m. p.m.	

14.10 Examination and Testing of Physical Evidence. Once collected, physical evidence is usually examined and tested in a laboratory or other testing facility. Physical evidence may be examined and tested to identify its chemical composition; to establish its physical properties; to determine its conformity or lack of conformity to certain legal standards; to establish its operation, inoperation, or malfunction; to determine its design sufficiency or deficiency, or other issues that will provide the fire investigator with an opportunity to understand and determine the origin of a fire, the specific cause of a fire, the contributing factors to a fire's spread, or the responsibility for a fire. The investigator should consult with the laboratory or other testing facility to determine what specific services are provided and what limitations are in effect.

14.10.1 Laboratory Examination and Testing. A wide variety of standardized tests are available, depending on the physical evidence and the issue or hypothesis being examined or tested. Such tests should be performed and carried out by procedures that have been standardized by some recognized group. Such conformance better ensures that the results are valid and that they will be comparable to results from other laboratories or testing facilities.

It should be noted that the results of many laboratory examinations and tests may be affected by a variety of factors. These factors include the abilities of the person conducting or interpreting the test, the capabilities of the particular test apparatus, the maintenance or condition of the particular test apparatus, sufficiency of the test protocol, and the quality of the sample or specimen being tested. Fire investigators should be aware of these factors when using the interpretations of test results.

If it is determined that testing might alter the evidence, interested parties should be notified prior to testing to allow them an opportunity to object or be present at the testing. Guidance regarding notification can be found in ASTM E 860, *Standard Practice for Examining and Testing Items That Are or May Become Involved in Product Liability Litigation*. (See also 14.5.3.4.)

14.10.2 Test Methods. The following is a listing of selected analytical methods and tests that are applicable to certain fire investigations. When utilizing laboratories to perform any of these tests, investigators should be aware of the quality of the laboratory results that can be expected.

14.10.2.1 Gas Chromatography (GC). The test method separates the mixtures into their individual components and then provides a graphical representation of each component and its relative amount. The method is useful for mixtures of gases or liquids that can be vaporized without decomposition. Gas chromatography is sometimes a preliminary test that may indicate the need for additional testing to specifically identify the components. For most petroleum distillate accelerants, gas chromatography provides adequate characterization if conducted according to accepted methods. These methods are described in ASTM E 1387, *Standard Test Method for Ignitable Liquid Residues in Extracts from Fire Debris Samples by Gas Chromatography*.

14.10.2.2 Mass Spectrometry (MS). This test method is usually employed in conjunction with gas chromatography. The method further analyzes the individual components that have been separated during gas chromatography. Methods of GC/MS analysis are described in ASTM E 1618, *Standard Test Method for Ignitable Liquid Residues in Extracts from Fire Debris by Gas Chromatography–Mass Spectrometry*.

14.10.2.3 Infrared Spectrophotometer (IR). This test method can identify some chemical species by their ability to absorb infrared light in specific wavelength regions.

14.10.2.4 Atomic Absorption (AA). This test method identifies the individual elements in nonvolatile substances such as metals, ceramics, or soils.

14.10.2.5 X-Ray Fluorescence. This test analyzes for metallic elements by evaluating an element's response to X-ray photons.

14.10.2.6 Flash Point by Tag Closed Tester (ASTM D 56). This test method, from ASTM D 56, *Standard Test Method for Flash Point by Tag Closed Tester*, covers the determination of the flash point, by tag closed tester, of liquids having low viscosity and a flash point below 200°F (93°C). Asphalt and those liquids that

tend to form a surface film under test conditions and materials that contain suspended solids are tested using the Pensky-Martens (*see 14.10.2.8*) closed tester.

14.10.2.7 Flash and Fire Points by Cleveland Open Cup (ASTM D 92). This test method, from ASTM D 92, *Standard Test Method for Flash and Fire Points by Cleveland Open Cup*, covers determination of the flash and fire points of all petroleum products (except oils) and those products having an open-cup flash point below 175°F (79°C).

14.10.2.8 Flash Point by Pensky-Martens Closed Tester (ASTM D 93). This test method, from ASTM D 93, *Standard Test Method for Flash Point by Pensky-Martens Closed Cup Tester*, covers the determination of the flash point by Pensky-Martens closed-cup tester of fuel oils, lubricating oils, suspensions of solids, liquids that tend to form a surface film under test conditions, and other liquids.

14.10.2.9 Flash Point and Fire Point of Liquids by Tag Open-Cup Apparatus (ASTM D 1310). This test method, from ASTM D 1310, *Standard Test Method for Flash Point and Fire Point of Liquids by Tag Open-Cup Apparatus*, covers the determination by tag open-cup apparatus of the flash point and fire point of liquids having flash points between 0°F and 325°F (–18°C and 163°C) and fire points up to 325°F (163°C).

14.10.2.10 Flash Point by Setaflash Closed Tester (ASTM D 3828). This test method, from ASTM D 3828, *Standard Test Methods for Flash Point by Small Scale Closed Tester*, covers procedures for the determination of flash point by a Setaflash closed tester. Setaflash methods require smaller specimens than the other flash point tests.

14.10.2.11 Autoignition Temperature of Liquid Chemicals (ASTM E 659). This test method, from ASTM E 659, *Standard Test Method for Autoignition Temperature of Liquid Chemicals*, covers the determination of hot- and cool-flame autoignition temperatures of a liquid chemical in air at atmospheric pressure in a uniformly heated vessel.

14.10.2.12 Heat of Combustion of Hydrocarbon Fuels by Bomb Calorimeter (High-Precision Method) (ASTM D 2382). This test method, from ASTM D 2382, *Standard Test Method for Heat of Combustion of Hydrocarbon Fuels by Bomb Calorimeter (High Precision Method)*, covers the determination of the heat of combustion of hydrocarbon fuels. It is designed specifically for use with aviation fuels when the permissible difference between duplicate determinations is of the order of 0.1 percent. It can be used for a wide range of volatile and nonvolatile materials where slightly greater differences in precision can be tolerated.

14.10.2.13 Flammability of Apparel Textiles (ASTM D 1230). This test method, from ASTM D 1230, *Standard Test Method for Flammability of Apparel Textiles*, covers the evaluation of the flammability of textile fabrics as they reach the consumer for or from apparel other than children's sleepwear or protective clothing.

14.10.2.14 Cigarette Ignition Resistance of Mock-up Upholstered Furniture Assemblies (ASTM E 1352). This test method, from ASTM E 1352, *Standard Test Method for Cigarette Ignition Resistance of Mock-up Upholstered Furniture Assemblies*, is intended to cover the assessment of the resistance of upholstered furniture mock-up assemblies to combustion after exposure to smoldering cigarettes under specified conditions.

14.10.2.15 Cigarette Ignition Resistance of Components of Upholstered Furniture (ASTM E 1353). This test method, from ASTM E 1353, *Standard Test Methods for Cigarette Ignition Resistance of Components of Upholstered Furniture*, is intended to evaluate the ignition resistance of upholstered furniture component assemblies when exposed to smoldering cigarettes under specified conditions.

14.10.2.16 Flammability of Finished Textile Floor-Covering Materials (ASTM D 2859). This test method, from ASTM D 2859, *Standard Test Method for Flammability of Finished Textile Floor Covering Materials*, covers the determination of the flammability of finished textile floor covering materials when exposed to an ignition source under controlled laboratory conditions. It is applicable to all types of textile floor coverings regardless of the method of fabrication or whether they are made from natural or manmade fibers. Although this test method may be applied to unfinished material, such a test is not considered satisfactory for the evaluation of a textile floor-covering material for ultimate consumer use.

14.10.2.17 Flammability of Aerosol Products (ASTM D 3065). This test method, from ASTM D 3065, *Standard Test Methods for Flammability of Aerosol Products*, covers the determination of flammability hazards for aerosol products.

14.10.2.18 Surface Burning Characteristics of Building Materials (ASTM E 84). This test method, from ASTM E 84, *Standard Test Method for Surface Burning Characteristics of Building Materials*, for the comparative surface burning behavior of building materials, is applicable to exposed surfaces, such as ceilings or walls, provided that the material or assembly of materials, by its own structural quality or the manner in which it is tested and intended for use, is capable of supporting itself in position or being supported during the test period. This test is conducted with the material in the ceiling position. This test is not recommended for use with cellular plastic.

14.10.2.19 Fire Tests of Roof Coverings (ASTM E 108). This test method, from ASTM E 108, *Standard Test Method for Fire Tests of Roof Coverings*, covers the measurement of relative fire characteristics of roof coverings under simulated fire originating outside the building. It is applicable to roof coverings intended for installation on either combustible or noncombustible decks, when applied as intended for use.

14.10.2.20 Critical Radiant Flux of Floor-Covering Systems Using a Radiant Heat Energy Source (ASTM E 648). This test method, from ASTM E 648, *Standard Test Method for Critical Radiant Flux of Floor-Covering Systems Using a Radiant Heat Energy Source*, describes a procedure for measuring the critical radiant flux of horizontally mounted floor covering systems exposed to a flaming ignition source in graded radiant heat energy environment in a test chamber. The specimen can be mounted over underlayment or to a simulated concrete structural floor, bonded to a simulated structural floor, or otherwise mounted in a typical and representative way.

14.10.2.21 Room Fire Experiments (ASTM E 603). This guide, ASTM E 603, *Standard Guide for Room Fire Experiments*, covers full-scale compartment fire experiments that are designed to evaluate the fire characteristics of materials, products, or systems under actual fire conditions. It is intended to serve as a guide for the design of the experiment and for the interpretation of its results. ASTM E 603 may be used as a guide for establishing laboratory conditions that simulate a given set of fire conditions to the greatest extent possible.

14.10.2.22 Concentration Limits of Flammability of Chemicals (ASTM E 681). This test method, from ASTM E 681, *Standard Test Method for Concentration Limits of Flammability of Chemicals*, covers the determination of the lower and upper concentration limits of flammability of chemicals having sufficient vapor pressure to form flammable mixtures in air at 1 atmosphere pressure at the test temperature. This method may be used to determine these limits in the presence of inert dilution gases. No oxidant stronger than air should be used.

14.10.2.23 Measurement of Gases Present or Generated During Fires (ASTM E 800). Analytical methods for the measurement of carbon monoxide, carbon dioxide, oxygen, nitrogen oxides, sulfur oxides, carbonyl sulfide, hydrogen halide, hydrogen cyanide, aldehydes, and hydrocarbons are described in ASTM E 800, *Standard Guide for Measurement of Gases Present or Generated During Fires*, along with sampling considerations. Many of these gases may be present in any fire environment. Several analytical techniques are described for each gaseous species, together with advantages and disadvantages of each. The test environment, sampling constraints, analytical range, and accuracy often dictate use of one analytical method over another.

14.10.2.24 Heat and Visible Smoke Release Rates for Materials and Products (ASTM E 906). This test method, from ASTM E 906, *Standard Test Method for Heat and Visible Smoke Release Rates for Materials and Products*, can be used to determine the release rates of heat and visible smoke from materials and products when exposed to different levels of radiant heat using the test apparatus, specimen configurations, and procedures described in this test method.

14.10.2.25 Pressure and Rate of Pressure Rise for Combustible Dusts (ASTM E 1226). This test method, from ASTM E 1226, *Test Method for Pressure and Rate of Pressure Rise for Combustible Dusts*, can be used to measure composition limits of explosibility, ease of ignition, and explosion pressures of dusts and gases.

14.10.2.26 Heat and Visible Smoke Release Rates for Materials and Products Using an Oxygen Consumption Calorimeter (ASTM E 1354). This test method, from ASTM E 1354, *Standard Test Method for Heat and Visible Smoke Release Rates for Materials and Products Using an Oxygen Consumption Calorimeter*, is a bench-scale laboratory instrument for measuring heat release rate, radiant ignitability, smoke production, mass loss rate, and certain toxic gases of materials.

14.10.2.27 Ignition Properties of Plastics (ASTM D 1929). This test method, from ASTM D 1929, *Standard Test Method for Determining Ignition Temperature of Plastics*, covers a laboratory determination of the self-ignition and flash-ignition temperatures of plastics using a hot-air ignition furnace.

14.10.2.28 Flammability of Apparel Fabrics by Semi-Restraint Method (ASTM D 3659). This test method, from ASTM D 3659, *Standard Test Method for Flammability of Apparel Fabrics by Semi-Restraint Method*, covers the evaluation of the flammable properties of fabrics in a vertical configuration.

14.10.2.29 Dielectric Withstand Voltage (Mil-Std-202F Method 301). This test method, from Mil-Std-202F, *Test Method for Electronic and Electrical Components*, also called high-potential/, over-potential/, voltage-breakdown/, or dielectric-strength/test, consists of the application of a voltage higher than rated

voltage for a specific time between mutually insulated portions of a component part or between insulated portions and ground.

14.10.2.30 Insulation Resistance (Mil-Std-202F Method 302). This test, from Mil-Std-202F, *Test Method for Electronic and Electrical Components*, measures the resistance offered by the insulating members of a component part to an impressed direct voltage tending to produce a leakage current through or on the surface of these members.

14.10.3 Sufficiency of Samples. Fire investigators often misunderstand the abilities of laboratory personnel and the capabilities of their scientific laboratory equipment. These misconceptions usually result in the fire investigator's collecting a quantity of physical evidence that is too small to examine or test.

Certainly, the fire investigator will not always have the opportunity to determine the quantity of physical evidence he or she can collect. Often, the fire investigator can collect only that quantity that is discovered during his or her investigation.

Each laboratory examination or test requires a certain minimum quantity of physical evidence to facilitate proper and accurate results. The fire investigator should be familiar with these minimum requirements. The laboratory that examines or tests the physical evidence should be consulted concerning these minimum quantities.

14.10.4 Comparative Examination and Testing. During the course of certain fire investigations, the fire investigator may wish to have appliances, electrical equipment, or other products examined to determine their compliance with recognized standards. Such standards are published by the American Society for Testing and Materials, Underwriters Laboratories Inc., and other agencies.

Another method of comparative examination and testing involves the use of an exemplar appliance or product. Utilizing an exemplar allows the testing of an undamaged example of a particular appliance or product to determine whether or not it was capable of causing the fire. The sample should be the same make and model as the product involved in the fire.

14.11 Evidence Disposition. The fire investigator is often faced with disposing of evidence after an investigation has been completed. The investigator should not destroy or discard evidence unless proper authorization is received. Circumstances may require that evidence be retained for many years and ultimately may be returned to the owner.

Criminal cases such as arson require that the evidence be kept until the case is adjudicated. During the trial, evidence submitted — such as reports, photographs, diagrams, and items of physical evidence — will become part of the court record and will be kept by the courts. Volatile or large physical items may be returned to the investigator by the court. There may be other evidence still in the investigator's possession that was not used in the trial. Once all appeals have been exhausted, the investigator may petition the court to either destroy or distribute all of the evidence accordingly. A written record of authorization to dispose of the evidence should be kept. The criminal investigator should be mindful of potential civil cases resulting from this incident, which may require retention of the evidence beyond the criminal proceedings.

Chapter 15 Origin Determination

15.1 Introduction. This chapter recommends a procedure to follow in determining the origin of a fire. Chapter 16 further develops the investigative efforts based on the results from the origin determination. Generally, if the origin of a fire cannot be determined, the cause cannot be determined.

Determination of the origin of the fire frequently involves the coordination of information derived from the following:

- (1) The physical marks (fire patterns) left by the fire
- (2) The observations reported by persons who witnessed the fire or were aware of conditions present at the time of the fire
- (3) The analysis of the physics and chemistry of fire initiation, development, and growth as an instrument to related known or hypothesized fire conditions capable of producing those conditions
- (4) Noting the location where electrical arcing has caused damage and the electrical circuit involved (*see Section 6.10*)

In some instances, a single item, such as an irrefutable article of physical evidence or dependable eyewitness to the initiation, can be the basis for a conclusive determination of origin. In most cases, however, no single item is sufficient in itself. The investigator then should use all of the available resources in developing potential scenarios and determining which scenarios plausibly fit all of the evidence available. When an apparently plausible scenario fails to fit some item of evidence, it is critical that the investigator determine whether the scenario or the evidence is erroneous. In some cases, it will be impossible to unquestionably fix the origin of a fire. It is important that the determination of a single point of origin not be made unless the evidence is conclusive. Where a single point cannot be identified, it can still be valuable for many purposes to identify possible sources of origin. In such instances, the investigator should provide a complete list of plausible explanations for the origin with the supporting evidence for each option.

The various activities of origin determination often occur simultaneously with those of cause investigation and failure analysis. Likewise, recording the scene, note taking, photography, and evidence identification and collection are performed simultaneously with these efforts. Generally, the various activities of origin determination will follow a routine sequence, while the specific actions within each activity are taking place at the same time.

The area of origin is almost always determined by examining the fire pattern evidence of the fire scene, starting with the areas of least damage and moving toward the areas of greatest damage. If identifiable, movement and intensity fire patterns should be traced back to an area or point of origin. Once the area of origin has been established, the investigator should be able to understand and document the fire spread. The purpose of determining the origin of the fire is to identify the geographical location where the fire began. Once the area of origin has been determined, based on the patterns produced by the movement of heat, flame, and smoke, then the specific location of the origin can be identified. The specific origin will be where the heat ignited the first fuel and is commonly referred to as the point of origin.

Investigators should establish a systematic procedure to follow for each type of incident. By following a familiar procedure, the investigator can concentrate on the incident at hand and need not dwell on the details of what the next step in the procedure will be. More important, the investigator may avoid inadvertently overlooking a significant facet of the investigation.

This chapter discusses a recommended procedure for the examination of the fire scene evidence. Basically, this procedure consists of a preliminary scene examination, development of a preliminary fire-spread scenario, an in-depth examination of the fire scene, a fire scene reconstruction, development of a final fire-spread scenario, and identification of the fire's origin.

Throughout this chapter, the discussion addresses the recommended technique to follow when examining fire scene evidence. This technique serves to inform the investigator but is not meant to limit the origin determination to only this procedure. All aspects of the fire event should be considered by the investigator during the investigation. Such aspects as witness statements, the investigator's expertise, and fire-fighting procedures play important roles in the determination of the fire origin. However, these aspects are addressed in other areas of this guide and in other texts on these subjects.

15.2 Fire Damage Assessment. Investigators will be making assessments of fire spread throughout the examination of the scene. These assessments include recognizing and documenting heat movement and intensity patterns and analyzing the importance and direction of each pattern found. (*See Chapters 4 and 13.*)

15.2.1 Notes. During this process, the investigator should be making detailed, written or tape-recorded notes. These notes should list all the pertinent observations, including the type, location, description, and measurements of the patterns; the material on which the patterns are displayed; and the investigator's analysis of the direction and intensity of the patterns.

15.2.2 Photography. The patterns should be photographed several different ways to effectively show their shape, size, relationship to other patterns, and the location within the fire scene. These variations should include changes in the viewing angle of the camera when documenting the pattern and different lighting techniques to highlight the texture of the pattern.

15.2.3* Vector Diagrams. The use of heat and flame vector diagrams can be a very useful tool for analysis by the investigator. Vectoring is applied by constructing a diagram of the scene. The diagram should include walls, doorways and doors, windows, and any pertinent furnishings or contents. Then, through the use of arrows, the investigator notes his or her interpretations of the direction of heat or flame spread based upon the identifiable fire patterns present. The arrows can point in the direction of fire travel from the heat source, or point back toward the heat source, as long as the direction of the vectors is consistent throughout the diagram. The arrows can be labeled to show any one of several variable factors, such as temperature, duration of heating, heat flux, or intensity. An example is shown in Figure 15.2.3.

FIGURE 15.2.3 Heat and vector analysis diagram showing vectors of the physical size and direction of heat travel of the fire pattern. (Source: Kennedy and Shanley, “USFA Fire Burn Pattern Tests — Program for the Study of Fire Patterns.”)

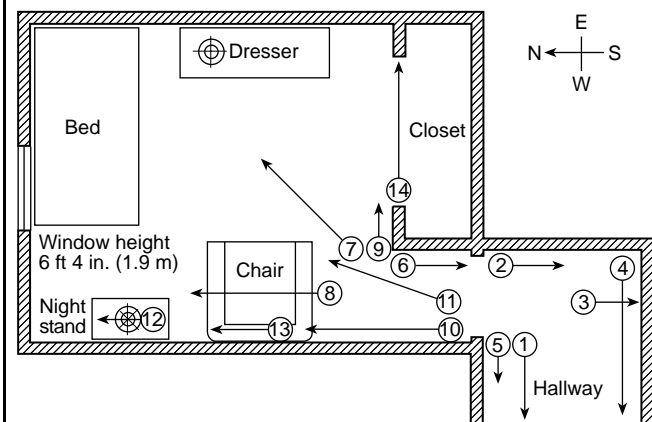

Complementary vectors can be added together to show actual heat movement directions. In that case, the investigator should clearly identify which vectors represent actual fire patterns and which vectors represent heat flow derived from the investigator's interpretations of these patterns. A vector diagram can give the investigator an overall viewpoint to analyze. The diagram can also be used to identify any conflicting patterns that need to be explained.

An important point to be made regarding this discussion is the terminology *heat source* and *source of heat*. These terms are not synonymous with the origin of the fire. Instead, these terms relate to any heat source that creates an identifiable fire pattern. The heat source may or may not be generated by the initial fuel. An example of this would be a fire that spreads into a garage and ignites the flammable liquids stored there. These flammable liquids then produce a new heat source that produces fire patterns on the garage's surfaces. Therefore it is imperative that the use of heat and flame vector analysis be tempered by an accurate understanding of the progress of the fire and basic fire dynamics.

15.2.4 Depth-of-Char Survey Grid Diagrams. The investigator should record in his or her notes the results of any depth-of-char surveys that are conducted. This notation should be documented in the notes as well as on a drawn diagram. For analysis purposes, the investigator can construct a depth-of-char grid diagram. On this diagram, the char measurements are recorded on graph paper to a convenient scale. Once the depth-of-char measurements have been recorded on the diagram, lines are drawn connecting points of equal, or nearly equal, char depths. The resulting “isochars” may display identifiable lines of demarcation and intensity patterns.

15.3 Preliminary Scene Assessment. An initial assessment should be made of the fire scene. This assessment should begin from the areas of least damage to the areas of greatest damage and should include an overall look at the structure, both exterior and interior, and at all pertinent areas surrounding the building. The purpose of this initial examination is to determine the scope of the investigation, such as equipment and manpower needed, to determine the safety of the fire scene, and to determine the areas that warrant further study.

Descriptions of all locations should be as precise as possible. Directions should be oriented to a compass or to a reference, such as the front of the structure. In every instance, the

location, and any related discussion, should be stated in such a fashion that others using the description can clearly locate the area in question.

15.3.1 Surrounding Areas. Investigators should include in their examination the areas around the structure. These areas may exhibit significant evidence or fire patterns, away from the involved structure, that enable the investigator to better define the site and the investigation. Anything of interest should be documented as to its location in reference to the structure.

Surrounding areas should be examined for evidence that may relate to the incident, such as contents from the burned structure and fire patterns. This phase of the examination can be used to canvas the neighborhood for witnesses to the fire and for persons who could provide information about the building that burned.

15.3.2 Weather. Analyze weather factors that may have influenced the fire. The surrounding area may provide evidence of the weather conditions. Wind direction may be indicated by smoke movement or by fire damage on the surrounding structures or vegetation.

15.3.3 Structural Exterior. A walk around the entire structure may reveal the extent and location of damage and may help determine the size of the scene that should be examined as well as the possibility of extension from an outside fire source. The construction and use of the structure should be noted. The construction refers to how the building was built, types of materials used, exterior surfaces, previous remodeling, and any unusual features that may have affected how the fire began and spread. A significant consideration is the degree of destruction that can occur in a structure consisting of mixed types and methods of construction. For instance, if a structure consists of two parts, one built in the early 1900s and the second built in the 1960s, the degree of destruction can vary considerably within these two areas, with all other influencing factors being equal.

The nature of occupancy refers to the current use of the building. Use is defined as the activities conducted; the manner in which such activities are undertaken; and the type, number, and condition of those individuals occupying the space. If the use of the building has changed from what it was originally built for, this change should be considered.

The fire damage on the exterior should be noted to assist in determining those areas that warrant further study. An in-depth examination of the damage is not necessary at this point in the investigation.

15.3.4 Structure Interior. On the initial assessment, investigators should examine all rooms and areas of the structure. The investigator should be observant of conditions of occupancy, including methods of storage, nature of contents, and shape of living conditions. The type of construction and surface covering should be noted. Moving from the least burned to the most burned areas, indicators of smoke and heat movement, areas of fire damage, and extent of damage in each area — severe, moderate, minor, or none — should be noted. This damage should be compared with the damage seen on the exterior. The investigator should use this opportunity to assess the soundness of the structure so that the safety of the structure can be determined. See Chapter 10 for further information regarding safety.

The primary purpose of the preliminary interior assessment is to identify the areas that require closer examination. Therefore, the investigator should be observant for possible

fire origins, fire patterns, fuel loading, burning, and potential ignition sources.

During this assessment, the investigator should note any indication of post-fire site alterations. Site alterations can include debris removal or movement, content removal or movement, electrical service panel alterations to facilitate temporary lighting, and gas meter removal. Such alterations can greatly affect the investigator's interpretation of the physical evidence. If site alterations are indicated, the persons who altered the site should be questioned as to the extent of their alterations and the documentation they may have of the unaltered site.

At the conclusion of the preliminary scene assessment, the investigator should have determined the safety of the fire scene, the probable staffing and equipment requirements, and the areas around and in the structure that will require a detailed inspection. The preliminary scene assessment is an important aspect of the investigation. The investigator should take as much time in this assessment as is needed to make these determinations. Time spent in this endeavor will save much time and effort in later steps of the investigation.

15.4 Preliminary Scenario Development. The identification of areas of interest results from formulating a preliminary scenario as to how the fire spread through the structure. This preliminary scenario is developed by noting the areas of greater destruction and lesser destruction and by attempting to track the fire back to its source. Such a scenario allows the investigator to organize and plan for the work to be done. The development of the preliminary scenario is a critical point in the investigation. It is important at this stage that the investigator attempt to identify any other feasible scenarios and, through the remaining course of the investigation, keep these alternative scenarios under consideration until or at such time as conclusive evidence or rationale is developed for setting them aside.

One very important consideration should be kept in mind, however. The investigation should not be planned solely to prove the preliminary scenario to the detriment of maintaining an unbiased mind. The investigation is intended to identify all facts that exist and to use those facts to develop opinions based on sound fire science principles and experience. The investigative effort may cause the scenario to change many times before the final opinion is formed. These changes are why the scenario should be considered preliminary until the investigation is completed. A narrow-minded approach to this effort prevents the normal development of the scenario from preliminary to final. (*See Chapter 2.*)

The investigator should continue to reevaluate the areas of interest by considering the additional data accumulated as the investigation progresses. The examination and documentation of heating, ventilation, and air-conditioning (HVAC) systems; fire protection systems; cooking and other appliances; electrical distribution systems; and utilities should be included. The areas to be examined should not be limited to those that suffered fire damage. Examination of the systems that have little or no fire damage may provide assistance later in identifying the cause for the fire.

15.5 Detailed Exterior Surface Examination. Once the preliminary scene assessment is completed, the structure should be analyzed in detail. The purpose of this effort is to identify where the fire began. This analysis begins with the exterior surface examination.

Even if the fire clearly originated from within the structure, the exterior analysis should be performed. Observations, pho-

tographs, and sketches can help orient the investigator to the structure, help to determine the manner in which the structure burned, and document details that may resolve issues that have not yet been raised.

15.5.1 Pre-fire Conditions. The pre-fire conditions of the structure should be determined. Such details as state of repair, condition of foundations and chimneys, insect damage, state of repair of fire suppression systems, and so forth may prove to be significant data. Documentation of these conditions at this time may be the only opportunity to record them.

15.5.2 Utilities. The investigator should locate and document the utilities associated with the structure, including the type and rated size of the electrical service and the fuel gas type. The meter readings for the utilities that provide them should be recorded. The locations of fuel tanks and their manner of connection to the structure should be noted.

15.5.3 Doors and Windows. The condition of each door, especially those that allow access to the structure, should be documented. The investigator should note whether the door is intact or broken and whether it has been forced open. The means of securing the door, such as dead bolt, padlock, and so forth, should be documented. If the door is broken, the investigator should determine whether the door was broken before or after the fire began. In some cases this can be accomplished by inspecting the splintered wood and noting whether it is burned or unburned and whether it is clean of smoke or smoke stained. Sometimes, observing whether the hidden surfaces on the door jamb or the hinges are clear of smoke can help determine the position of the door (i.e., open or closed) during the fire.

Clean surfaces indicate that the door was closed during the time smoke was present. However, stained surfaces do not always indicate the door was open. If smoke accumulates in sufficient quantity and if there is a pressure difference between the areas separated by the door, smoke can flow through cracks around a closed door to stain those hidden surfaces. The pressure differences involved can be due to the fire-produced smoke temperatures; mechanically produced air movement from ventilation, exhaust, or similar fan-driven systems; wind effects; or buoyant (stack) effects caused by the temperature differentials between the building and the exterior environment.

The condition of the windows and the glass should be documented. To ascertain what position the windows were in during the fire, the same characteristics that were discussed with the doors apply. With broken glass, the location of the pieces may provide insight as to what broke the pane. Once the fire breaches either the doors or windows, the improved ventilation affects the rate of combustion of the fire and the manner in which it spreads in the structure. The investigator should strive to learn whether the opening occurred prior to, during, or after extinguishment of the fire.

15.5.4 Explosion Evidence. Any displacement of the exterior surfaces should be documented. The distance the pieces traveled and the extent of movement of walls and roofs should be noted on a diagram of the structure. Charring or smoke staining on hidden surfaces, which became exposed by the displacement of the structural component, should be noted on the diagram also. A detailed discussion of explosions can be found in Chapter 18.

15.5.5 Fire Damage. The fire damage on the exterior surfaces should be documented. The investigator should pay particular attention to the damage that is associated with natural

and unnatural openings. Window, door, and vent openings provide natural passages for smoke and heat and can be indicators of the flow of fire and fire products. Unnatural openings include holes created by the fire and holes created during the suppression effort. Holes created by the fire indicate an area of intense burning inside the structure. Separate and distant holes created by fire can be indicative of multiple origins, concentrated fuel loads, or simply a spreading fire that developed more than one intense impact on a vulnerable point in the structure envelope.

Holes created by fire suppression activities are generally associated with forced entry attempts, ventilation of the combustion gases, or spot-fire extinguishment. Ventilation attempts can greatly affect fire movement inside the building, thereby creating fire patterns that appear abnormal. Investigators should use care in evaluating such fire damage by conferring with the fire combat personnel to learn what happened inside the structure when the ventilation took place. Such evidence can be helpful in appraising, through methods such as vectoring, the flow of fire and fire effects.

15.6 Detailed Interior Surface Examination. An interior surface examination generally is performed before any attempt is made to formulate an opinion as to fire origin. In the majority of structure fires, the origin is within the structure, and no finite origin determination is possible by just an exterior examination. In the event the fire clearly did not begin inside, the interior should still be evaluated and documented. Many issues can arise from a fire's occurrence that do not relate to origin determination. Photographs and diagrams of the interior can provide answers to questions that arise from these issues.

The interior surface examination will follow a procedure similar to the exterior surface examination. The analysis of the fire damage should utilize the same techniques discussed in Section 15.5.

15.6.1 Pre-fire Conditions. The pre-fire conditions in the interior of the structure should be documented, especially in the areas where there was fire development and spread. The housekeeping, or lack of it, should be noted. The presence of any evidence of concentrations of easily ignitable materials, such as trash, should be noted. The investigator should note whether the electrical devices are properly utilized. Any indications that might relate to electrical overloading, power cord abuse, appliance abuse, and so forth should be noted. These do not solely determine a fire cause, but they can be supportive, or contradictory, to subsequent cause determinations.

Any interior fire suppression or fire protection devices such as smoke alarms, fire extinguishing systems, fire doors, and so forth should be located. The investigator should determine whether they are in working order and whether they functioned properly during the fire. The investigator should note whether they have been disabled or inadequately maintained.

The investigator should look at the fuel loads present in the structure and should note whether they are consistent with what is expected in this structure and whether they added to the fire's development. The fuel load considerations should include the interior surface covering and furnishings.

The ultimate determination is whether the pre-fire conditions created the fire or greatly contributed to the fire's origin, cause, or spread.

15.6.2 Utilities. The condition of the utility services in the structure should be located and documented. Documentation may involve simply photographing the electrical distribution panel for a home, or it may involve studying a complex electri-

cal distribution system for a large industrial building. In either event, the type and method used to distribute electricity should be determined, and damage to the systems should be documented.

The fuel gas utility should be identified and documented. The purpose of this examination is to assist in determining whether the fuel gas contributed to the fire's spread. If the examination reveals that fuel gases may have had a role in the fire's spread, then the distribution system should be examined in detail, including pressure testing for leaks. Remember, fires can, and usually do cause a perfectly good gas distribution system to leak.

15.6.3 Explosion. The procedure used in the exterior surface examination should also be used inside the building. Any displacement of interior structures should be noted, including the distance of the displacement and the direction. The center of explosion damage should be located if possible.

Once the investigation has determined that an explosion has occurred, the investigator should try to determine whether the explosion preceded a fire or followed a fire's inception. This can sometimes be determined by noting the condition of normally hidden or protected surfaces, such as inside the walls. Unburned components from the structure, found outside the perimeter of the structure, can also be an indication of a pre-fire explosion. Post-fire explosions can produce flaming brands that have been propelled outside the structure. See Chapter 18 for a detailed discussion on the investigation of explosions.

15.7 Fire Scene Reconstruction. The purpose of fire scene reconstruction is to recreate as nearly as possible the state that existed prior to the fire. Such fire scene reconstruction allows the investigator to see the fire patterns on the exposed surfaces and enables the investigator to make a more accurate origin analysis. A further benefit is the probability that complete exposure of the fire scene will enable other persons to better visualize the fire patterns. Interviews, diagrams, photographs, and other means can be helpful in establishing pre-fire conditions.

Since the preliminary scene assessment has identified the areas warranting further study, the task of fire scene reconstruction may not require the removal of debris and the replacement of the contents throughout the entire structure. As mentioned previously, the preliminary scene assessment should not be done hastily. Careful analysis of the fire scene may help to reduce to a practical level the strenuous task of debris removal. If the area to be reconstructed cannot be reduced, then the investigator should accept the necessity of removing the debris from the entire area of destruction.

15.7.1 Safety. Another important consideration is safety during the reconstruction effort. Debris removal can weaken a structure and cause it to collapse. Debris removal can uncover holes in the floor and can expose energized electrical wiring. A recent development is the recognition of the risk to the investigator from hazardous substances. Risks encountered during an investigation should be minimized before the investigation continues. See Chapter 10 for a detailed discussion on safety.

15.7.2 Debris Removal. Adequate debris removal is essential. Inadequate removal of debris and the resultant exposure of only portions of the fire patterns can lead to gross misinterpretation of the fire patterns. A fire scene investigation involves dirty, strenuous work. Acceptance of this fact is the first step in conducting a proper fire investigation.

The removal of debris during overhaul is an area of concern to the fire investigator. Fire crews that remove all debris and contents from the fire scene may remove evidence, thus making origin determination more difficult. During the suppression stage of the fire ground activities, no more site alteration should be made than necessary to ensure extinguishment of the fire. When circumstances call for substantial site alterations, an attempt should be made to document the fire scene prior to the alterations if possible.

Use some thought as to where debris will be placed during reconstruction. Moving debris twice is counterproductive. Debris removal should be performed in a deliberate and systematic fashion. This means that debris should be removed in layers, with adequate documentation as the process continues. If more than one investigator is doing the removal, they should discuss the purpose for the debris removal and what they expect to find. A discussion may prevent one investigator from throwing away something the other investigator considers important.

15.7.3 Contents. Any contents or their remains that are uncovered during debris removal should be noted as to their location, condition, and orientation. This precaution is important to the replacement of these contents in their pre-fire positions. Once the debris has been removed, the contents should be placed in their pre-fire positions for analysis of the fire patterns on them.

When the contents have been displaced during fire suppression activities, post-fire replacement becomes much more difficult. Usually the position where the item sat will bear a mark from the item, such as table legs leaving small clear spots on the floor. The problem is knowing which leg goes to which spot. If a definite determination is not possible, then the item should not be included in the fire scene reconstruction. A guess as to how contents were oriented can be wrong, thereby contributing false data to the analysis process. An alternative is to document the contents in all probable positions in the hope that later information will pinpoint the true location.

15.7.4 Models in Reconstruction. In recent years, the development of fire science and technology has produced a number of analytical tools derived from the physics and chemistry of fire and the measurement of the property of materials. Many of these are in the form of collected interrelated calculations frequently called *fire models*. The analytical reconstruction techniques provide an additional tool in the analysis of the fire and origin determinations. Until very recently, the computational methods required large computers and a high level of science expertise to use and understand the meaning and validity of the outputs.

Currently a series of more user-friendly, simpler-to-operate analytical tools have emerged. Some can be executed with simple handheld calculators. Most, however, require the modern personal computer as the minimum tool. As emerging tools, these fire models require varying degrees of expertise by the user. In general, the user of a fire model is responsible for ascertaining that the method used is appropriate, that the data input is proper, and that the output is properly interpreted. Those who are not sufficiently informed to have an adequate level of confidence so that they can support the use of the fire models and their validity, if challenged, should not unilaterally use such methods. Users who do not have that competence should not use these analytical tools without the guidance and assistance of a person who can take that responsibility. Because of the value of these tools, however, practitioners are urged to

become aware of them and to study, understand, and use those most appropriate to their needs and capabilities.

15.8 Fire-Spread Scenario. Once the factual information is compiled from the exterior and interior surface examinations, the investigator should finalize the fire-spread scenario on how the fire spread in and on the structure. The purpose of the fire-spread scenario is to determine an area of fire origin. Contradictions to the scenario should be recognized and resolved. If resolution is not possible, then the scenario should be re-evaluated to minimize the contradictions. To resolve contradictions, the data should be re-examined to see whether another reason can be found for why the damage exists as it does. Other investigators can be enlisted to assist in the evaluation of the fire damage and its explanation. Ultimately, a weighing of the scenario against the remaining contradictions should be made to decide whether the determination of an area of origin is valid.

If an area of origin is identified, then all potential ignition sources should be located and identified for a further reduction of the area of origin to a point of origin.

If no determination is made as to the fire's origin, then the determination of the fire's cause becomes very difficult. In some instances, where no origin determination is possible, a witness may be found who saw the fire in its incipient stage and can provide the investigator with an area of fire origin. Such circumstances create a burden on the fire investigator to conduct as thorough an investigation as possible to find facts that can support or refute the witness's statements.

15.9 Total Burns. A fire that is allowed to burn unimpeded until it self-extinguishes due to a lack of fuel can present unique problems to the investigator. This does not mean, however, that such fire scenes are not worthy of investigation. While such circumstances generally produce fire scenes incapable of origin and cause determinations, some will render valuable information when subjected to a systematic and thorough analysis.

The information to be obtained includes the physical description of the structure and the type of construction. This information may be obtained from the insurance carrier, local zoning authorities, and local building officials. The local utilities should be consulted for information on the building's past and recent utility requirements.

In the case of the occupancy of the building, the insurance carrier, real estate officials, and neighbors should be consulted.

Even though the initial view of the site may show nothing other than a hole in the ground containing fire debris, the site should be approached systematically. A slow methodical search from the perimeter should be made by walking around the entire remains. All recognizable items should be noted and inspected. A site plan should be made with these items located on it.

Inspection within the perimeter may verify the floor plan of the structure. The noncombustible contents of the structure generally will be found almost directly beneath their pre-fire location. This generally will allow the investigator to identify the bathrooms, kitchens, and utility rooms.

Sometimes the vertical locations of contents will assist the investigator in determining what level they had occupied within the structure. For instance, bed frames from second story bedrooms will generally end up on top of the first story contents with debris sandwiched between them.

Once the initial site assessment is complete, the debris should be removed carefully and the contents located, identified, and studied. One of the benefits of this type of structural destruction is that the site is rarely altered by earlier investigations or overhaul operations.

A purpose of the examination of the contents is to determine whether the noncombustible contents found correspond to the type and amount of contents expected in a structure of the same occupancy. Residential structures contain essential contents such as refrigerators and heating systems, and most contain other contents such as televisions and cooking appliances. These items will survive to some degree even in the most severe fires.

Another purpose for studying the contents is to note the differing degrees of heating effects on them. If contents in one area of the structure exhibit melted metal remains while others do not, then the investigator can make the assumption that temperatures in one area exceeded temperatures in another. If the metal remains of the contents are badly oxidized, such examinations may not be possible.

Total burn fire scenes present their own unique problems, but then so do many other fire scenes. Although the primary objective of the fire investigator is to determine the origin and cause of a fire, there are areas of interest to other involved parties that deserve to be considered. Careful examination of totally burned sites can answer questions that may arise from these other parties long after the fire scene has been cleaned up.

Chapter 16 Cause Determination

16.1 General. While the focus of this chapter is on determining the cause of a fire or explosion incident, it is recognized that the purpose of fire investigations is often much broader. The ideal goal of any particular fire investigation is to come to a correct conclusion about the significant features of a particular fire or explosion incident. The significant features can be grouped under four headings, as follows.

(a) *The cause of the fire or explosion.* This feature involves a consideration of the circumstances, conditions, or agencies that bring together a fuel, ignition source, and oxidizer (such as air or oxygen), resulting in a fire or a combustion explosion.

(b) *The cause of damage to property resulting from the incident.* This feature involves a consideration of those factors that were responsible for the spread of the fire and for the extent of the loss, including the adequacy of fire protection, the sufficiency of building construction, and the contribution of any products to flame spread and to smoke propagation.

(c) *The cause of bodily injury or loss of life.* This feature addresses life safety components such as the adequacy of alarm systems, sufficiency of means of egress or in-place protective confinement, the role of products that emit toxic by-products that endanger human life, and the reason for fire fighter injuries or fatalities.

(d) *The degree to which human fault contributed to any one or more of the causal issues described in (a), (b), and (c).* This feature deals with the human factor in the cause or spread of fire or in bodily injury and loss of life. It encompasses acts and omissions that contribute to a loss, such as incendiarism and negligence.

The cause of a fire or the causes of damage or casualties may be grouped in broad categories for general discussion, for assignment of legal responsibility or culpability, or for reporting purposes. Local, state, or federal reporting systems or legal systems may have alternative definitions that should be applied as required.

The determination of the cause of a fire requires the identification of those circumstances and factors that were necessary for the fire to have occurred. Those circumstances and factors

include, but are not limited to, the device or equipment involved in the ignition, the presence of a competent ignition source, the type and form of the material first ignited, and the circumstances or human actions that allowed the factors to come together to allow the fire to occur. An individual investigator may not have responsibility for, or be required to address, all of the issues described in this section. A particular investigation may or may not require that all of these issues be addressed.

The cause of any particular fire may involve several circumstances and factors. For example, consider a fire that starts when a blanket is ignited by an incandescent lamp in a closet. The various factors include having a lamp hanging down too close to the shelf, putting combustibles too close to the lamp, and leaving the lamp on while not using the closet. The absence of any one of those factors would have prevented the fire. The function of the investigator is to identify those factors and circumstances that contributed to the cause.

16.2 Classification of the Cause. The cause of a fire may be classified as accidental, natural, incendiary (arson), or undetermined. Use of the term *suspicious* is not an accurate description of a fire cause. Mere suspicion is not an acceptable level of proof for making a determination of cause within the scope of this guide and should be avoided. Such fires should be classified as undetermined.

16.2.1 Accidental Fire Cause. Accidental fires involve all those for which the proven cause does not involve a deliberate human act to ignite or spread fire into an area where the fire should not be. In most cases, this classification will be clear, but some deliberately ignited fires can still be accidental. For example, in a legal setting, a trash fire might be spread by a sudden gust of wind. The spread of fire was accidental even though the initial fire was deliberate.

16.2.2 Natural Fire Cause. Natural fire causes involve fires caused without direct human intervention, such as lightning, earthquake, wind, and the like.

16.2.3 Incendiary Fire Cause. The incendiary fire is one deliberately ignited under circumstances in which the person knows that the fire should not be ignited.

16.2.4 Undetermined Fire Cause. Whenever the cause cannot be proven, the proper classification is *undetermined*. The fire might still be under investigation, and the cause may be determined later. In the instance in which the investigator fails to identify all of the components of the cause of the fire, it need not always be classified as undetermined. If the physical evidence establishes one factor, such as the presence of an accelerant, that may be sufficient to establish the cause even where other factors such as ignition source cannot be determined. Those situations are also encountered to a lesser degree in accidentally caused fires. Determinations under such situations are more subjective. Therefore, investigators should strive to keep an open unbiased thought process during an investigation.

16.2.5 Process of Elimination. Any determination of fire cause should be based on evidence rather than on the absence of evidence; however, when the origin of a fire is clearly defined, it is occasionally possible to make a credible determination regarding the cause of the fire, even when there is no physical evidence of that cause available. This finding may be accomplished through the credible elimination of all other potential causes, provided that the remaining cause is consistent with all known facts.

For example, an investigator may properly conclude that the ignition source came from an open flame, even if the device producing the open flame is not found at the scene. This conclusion may be properly reached as long as the analysis producing the conclusion follows the scientific method as discussed in Chapter 2.

Elimination, which actually involves the testing and rejection of alternate hypotheses, becomes more difficult as the degree of destruction in the compartment of origin increases, and is not possible in many cases. Whenever an investigator proposes the elimination of a particular system or appliance as the ignition source, the investigator should be able to explain how the appearance or condition of that system or appliance would be different from what is observed, if that system or appliance were the cause of the fire.

There are times when such differences do not exist; for example, when a heat-producing device ignites combustibles that are placed too close to it, the device itself may appear no different than if something else were the ignition source.

The “elimination of all accidental causes” to reach a conclusion that a fire was incendiary is a finding that can rarely be justified scientifically, using only physical data; however, the “elimination of all causes other than the application of an open flame” is a finding that may be justified in limited circumstances, where the area of origin is clearly defined and all other potential heat sources at the origin can be examined and credibly eliminated. It is recognized that in cases where a fire is ignited by the application of an open flame, there may be no evidence of the ignition source remaining. Other evidence, such as that listed in Section 19.3, which may not be related to combustion, may allow for a determination that a fire was incendiary.

In a determination of an accidental cause, the same precautions regarding elimination of other causes should be carefully considered.

16.3 Source and Form of Heat of Ignition. The source of ignition energy will be at or near the point of origin, although in some circumstances the two may appear not to coincide. Some sources of ignition will remain at the point of origin in recognizable form, whereas others may be altered greatly or even completely destroyed. Nevertheless, the source should be identified in order for the cause to be proven. Sometimes the source can only be inferred, and the cause as found will be the most probable one.

A competent ignition source will have sufficient temperature and energy and will be in contact with the fuel long enough to raise it to its ignition temperature.

The ignition process involves the following three components: generation, transmission, and heating, as follows.

(a) The competent ignition source will generate a level of energy sufficient to raise the fuel to its ignition temperature and will be capable of transmitting that level of energy to the fuel.

(b) Transmission of sufficient energy raises the fuel to its ignition temperature. Where the energy source is in direct contact with the fuel, such as the contact of an overheated wire with its insulation, the transfer is a direct conduction from the source to the fuel. Where there is a separation, however, there should be a form of energy transport. This transport can be by contact with the flaming gases from a burning item, by radiation from the flame or surfaces or gases heated by that flame, or a combination of heating by the flow of hot gases and radiation.

(c) Heating of the potential fuel will occur by the energy that reaches it. Each fuel reacts differently to the energy that impacts on it. Some energy may be reflected, and some energy

may be transmitted through the material. Some is dispersed through the material, and some heats the material, causing its temperature to rise. The term *thermal inertia* is used to describe the response of a material to the energy impacting on it. Thermal inertia is defined as the product of thermal conductivity, density, and specific heat. These three properties determine the manner in which a material will transmit heat from the exposed surface to its core or to an unexposed surface and distribute and absorb heat within the element itself. The surface temperature of a material with a low thermal inertia (such as foam plastic) will rise much more quickly when exposed to energy from a high-temperature source than will a material with higher thermal inertia (such as wood paneling). Thin materials will also heat more quickly from a given source of energy.

Once the area and possibly the point of origin is identified, the investigator should identify the heat-producing device, substance, or circumstance that could have caused the ignition. Heat-producing devices can include fixed and portable heaters, gas-fired or electric appliances, furnaces, water heaters, wood stoves, lamps, internal combustion engines, clothes dryers, and incendiary devices.

The investigator should also look for devices that may have malfunctioned. Such devices include many of the foregoing plus electrical service equipment, receptacles, kitchen and laundry appliances, motors, transformers, and heavy machinery.

Sources of ignition for gases or vapors include arcs from motors with brushes, arcs from switches that are not explosion-proof, gas or electric pilots, or flames in gas appliances.

Flammable gases or liquid vapors, such as those from gasoline, may travel a considerable distance before reaching an ignition source. Only under specific conditions will ignition take place, the most important condition being concentration within the flammable limits and an ignition source of sufficient energy located in the flammable mixture. This separation of the fuel source and the origin of the fire can cause confusion.

Information should be obtained from owners or occupants, when possible, about what potential ignition sources were in the area of origin, how and when they were used, and recent activities in the area. That type of gathering of information is especially important when the source of ignition does not survive the fire. The information would also be helpful in alerting an investigator to small or easily overlooked items when examining the area of origin. When electrical energy sources are considered as potential producers of the heat of ignition, the investigator should refer to Chapter 6 of this guide.

16.4 First Material Ignited. The first material ignited (initial fuel) is that which first sustains combustion beyond the igniting source. For example, the wood of the match would not be the initial fuel, but paper, flammable liquid, or draperies would be, if the match were used to ignite them.

The physical configuration of the fuel plays a significant role in its ability to be ignited. A nongaseous fuel with a high surface-to-mass ratio is much more readily ignitable than a fuel with a low surface-to-mass ratio. Examples of high surface-to-mass fuels include dusts, fibers, and paper. If the initial fuel has a high surface-to-mass ratio, then the intensity and duration characteristics for a heat source become less stringent. The higher the surface-to-mass ratio of the fuel, the less energy the heat source should produce to ignite the fuel, although the ignition temperature is the same. Gases and vapors are fully dispersed (in effect, an extremely high surface-to-mass ratio) and can be ignited by a low heat energy source instantly.

The initial fuel could be part of a device that malfunctions. Examples include insulation on a wire that is heated red hot by excessive current or the plastic case on an overheating coffee maker.

The initial fuel might be something too close to a heat-producing device. Examples are clothing against an incandescent lamp or a radiant heater, wood framing too close to a wood stove or fireplace, or combustibles too close to an engine exhaust manifold or catalytic converter.

The initial fuel is important for understanding the events that caused the fire. For example, if the remains of a match were found on the burned surface of a wood end table in the area of origin, one should not jump to the conclusion that the match ignited the wood tabletop. The match almost certainly would go out without igniting the solid wood surface. Maybe the match had been blown out and dropped there by an occupant. Was there any paper or other light fuel that could have carried flame to a chair or other fuels? Remember that the initial fuel must be capable of being ignited within the limitations of the ignition source. The components in most buildings are not susceptible to ready ignition. For example, flooring, drywall, structural lumber, wood cabinets, and carpeting do not ignite unless they are exposed to a substantial heat source. The investigator needs to identify easily ignited items that, once ignited, could provide the heat source to damage or involve these harder-to-ignite items.

Unusual residues might remain from the initial fuel. Those residues could arise from thermite, magnesium, or other pyrotechnic materials.

Gases and vapors can be the initial fuel and can cause confusion because the point of ignition can be some distance away from where sustained fire starts in the structure or furnishings. When ignition causes a low-order explosion, it is obvious that a gas, vapor, or dust is involved. Layered vapors of gasoline might not ignite violently so that, unless evidence of the accelerant is found, the source of ignition many feet from where the puddle burned might be difficult to associate with the fire.

16.5 Ignition Factor (Cause). A fuel by itself or an ignition source by itself does not create a fire. Fire results from the combination of fuel and an ignition source. Therefore, the investigator should be cautious about deciding on a cause of a fire just because a readily ignitable fuel and a potential ignition source are present. The sequence of events that allow the source of ignition and the fuel to get together establishes the cause.

To define the ignition sequence requires determining events and conditions that might have occurred or might have been created in the past. Furthermore, the order in which those past events occurred might have to be determined. Consider a fire in a restaurant kitchen that started when a deep-fat fryer ignited and spread fire through the kitchen. The cause is more than simply "the deep-fat fryer overheated." Was the control turned up too high? Did the control contacts stick? Why did the high temperature cutoff not prevent overheating? Those factors could make a difference between a minor incident and a large hostile fire. In each fire investigation, the various contributing factors should be investigated and included in the ultimate explanation of the ignition sequence.

The investigator is cautioned not to rule out a cause merely because there is no obvious evidence for it. Do not rule out the electric heater because there is no arcing in the wires or because the contacts are not stuck. Obviously, arson is not eliminated because the lab did not find accelerant in the evidence. The same standard applies to accidental fire causes.

Potential causes should be ruled out only if there is definite evidence that they could not have caused the fire. The electric heater can be ruled out if it was not plugged in. A smoldering cigarette can be ruled out if the room was well involved 10 minutes after a reliable witness passed through and saw no smoke.

16.6 Determining Responsibility. After determining the origin, cause, and development of a fire or explosion incident, the fire investigator may be required to do a failure analysis and to determine responsibility. It is only through the determination of such responsibility for the fire that remedial codes and standards, fire safety, or civil or criminal litigation actions can be undertaken.

16.6.1 Definition of Responsibilities. Responsibility for a fire or explosion incident here is defined as the accountability of a person or other entity for the event or sequence of events that caused the fire or explosion, spread of the fire, bodily injuries, loss of life, or property damage.

16.6.2 The Fire Investigator's Role in Assessing Responsibility. While it is frequently a court's role to affix a final finding of responsibility and to assign liability, remedial measures, compensation, or punishment, it is the fire analyst's task to identify responsibility so that fire safety, code enforcement, or litigation processes can be undertaken.

16.6.3 Nature of Responsibility. The nature of responsibility in a fire or explosion incident may be in the form of an act or omission. It may be something that was done, accidentally or intentionally, that ultimately brought about the fire or explosion, or it may be some failure to act to correct or prevent a condition that caused the incident, spread, injuries, or damage. Responsibility may be attributed to a fire or explosion event no matter the classification or nature of the cause: natural, accidental, incendiary, or even undetermined.

Responsibility may be attributed to the accountable person or other entity because of negligence, reckless conduct, product liability, arson, violations of codes or standards, or other means.

16.6.4 Degrees of Responsibility. Responsibility may fall on more than one subject. Often a series or sequence of events or conditions causes a fire or explosion and the resulting spread, injuries, and damage. A failure analysis often shows that a change to any one or more of these conditions, acts, or omissions could have prevented or mitigated the incident. In this way, responsibility may fall on more than one person or entity. In such a case, multiple or various degrees of responsibility may be assessed.

16.7 Opinions. When forming opinions from hypotheses about fires or explosions, the investigator should set standards for the degree of confidence in those opinions. Use of the scientific method dictates that any hypothesis formed from an analysis of the data collected in an investigation must stand the challenge of reasonable examination. (*See Chapter 2.*) [*See Daubert v. Merrell Dow Pharmaceuticals, Inc., 509 U.S. 579, 113 S.Ct. 2786 (1993).*]

Ultimately, the decision as to the level of confidence in data collected in the investigation or any hypothesis drawn from an analysis of the data rests with the investigator. The final opinion is only as good as the quality of the data used in reaching that opinion. If the confidence level of the opinion is only "possible" or "suspected," the cause should be listed as undetermined.

Chapter 17 Failure Analysis and Analytical Tools

17.1 Introduction. This chapter identifies methods available to assist the investigator in the analysis of a fire/explosion incident. Additional tools requiring special expertise are also discussed. These methods can be used to analyze fires of any size or complexity. In many cases, the methods are used to organize information collected during the documentation of the incident into a rational and logical format. They can also be used to identify aspects of the investigation needing additional information and where future efforts should be directed.

17.2 Time Lines. A time line is a graphic or narrative representation of events related to the fire incident, arranged in chronological order. The events included in the time line may occur before, during, or after the fire incident. This investigative tool can show relationships between events, identify gaps or inconsistencies in information and sources, assist in witness interviews, and otherwise assist in the analysis and investigation of the incident. A graphic time line is useful as a demonstrative document. The value of a time line is dependent upon the accuracy of the information used to develop the time line.

In order to construct a time line, it is necessary to relate events or activities to the time of their occurrence. In assigning time to events or activities, it is important to identify the confidence the investigator has in the assigned time. One means of doing this is to identify the quality of the data as hard time (actual) or soft (estimated or relative) time.

17.2.1 Hard time identifies a specific point in time that is directly or indirectly linked to a reliable clock or timing device of known accuracy. It is possible to have a time line with no hard times. Hard times can be obtained from sources such as the following:

- (1) Fire department dispatch telephone or radio logs
- (2) Police department dispatch and radio logs
- (3) Emergency Medical Service reports
- (4) Alarm system records (on-site, central station, fire dispatch, etc.)
- (5) Building inspection report(s)
- (6) Health inspection report(s)
- (7) Fire inspection report(s)
- (8) Utility company records (maintenance/emergency/repair records)
- (9) Private videos/photos (check with local film developers)
- (10) Media coverage (newspaper photographer, radio, television, magazines)
- (11) Timers (clocks, time clocks, security timers, water softeners, lawn sprinkler systems)
- (12) Weather reports (NOAA, airports, lightning tracking services)
- (13) Current and/or prior owner/tenant records (re: maintenance)
- (14) Interviews
- (15) Computer-based fire department alarms, communications audio tapes, and transcripts
- (16) Building or systems installation permits

Also see Chapter 11 of this document.

All clocks and timing devices are usually not synchronized. Discrepancies between different clocks should be recorded and adjustments made where necessary.

Soft time can be either estimated or relative time. *Relative time* is the chronological order of events or activities that can be identified in relation to other events or activities. *Estimated time* is an approximation based on information or calculations that may or may not be relative to other events or activities. Often, relative or estimated times can be determined within a known degree of accuracy, for example, bounded by two known events or within a time range. It may be desirable to report them as a time range rather than discrete time.

Relative time can be very subjective in nature. The concept of elapsed time varies with the individual and the stress caused by the incident. It is important to have witnesses be as specific as possible by referring to their actions and observations, in relation to each other and to other events. All relative time is based on an estimate. It is also possible to have events for which the estimated time cannot be related to a hard time but that are valuable to the analysis. These are referred to as *estimated times*. Relative or estimated times are generally provided by witnesses.

17.2.2 Potential sources of soft times include those sources for hard times listed in 17.2.1, along with estimation of times for an activity to be performed or an event to occur.

Some events are particularly valuable as a foundation for the time line or may have significant relation to the cause, spread, detection, or extinguishment of a fire. These are referred to as *benchmark events*. An example of a benchmark event could be the dispatch and arrival times of the fire fighters on the fire department incident report. Other examples may include events such as a roof collapsing, a window breaking out, or an explosion.

17.2.3 It is quite possible that two or more time lines will be required to effectively evaluate and document the sequence of events precipitating the fire, the actual fire incident, and post-fire activity. These time lines can be called *macro* and *micro*.

A macro evaluation of events may incorporate activity that occurred months before the fire and that terminated on the demolition of the building. As an example, this activity might include renovations that altered the building's electrical system and that may be attributable as the ignition source.

A micro evaluation of events focuses on some discrete segment of the total time line for which the investigator has a particular interest. For example, it may consist of an evaluation of events during the time period immediately prior to ignition, during initial fire fighting, during fire growth, or from ignition to extinguishment.

Parallel time lines can be presented to demonstrate two or more series of events. The purpose of such a presentation may be to show whether or not they are related in some manner.

Various tools are available to assist in the development of time lines. Although a simple time line can be constructed with pencil and paper, there are software packages available as well, from simple word processing or database, to sophisticated scheduling software. See Figure 17.2 for an example of a simple time line.

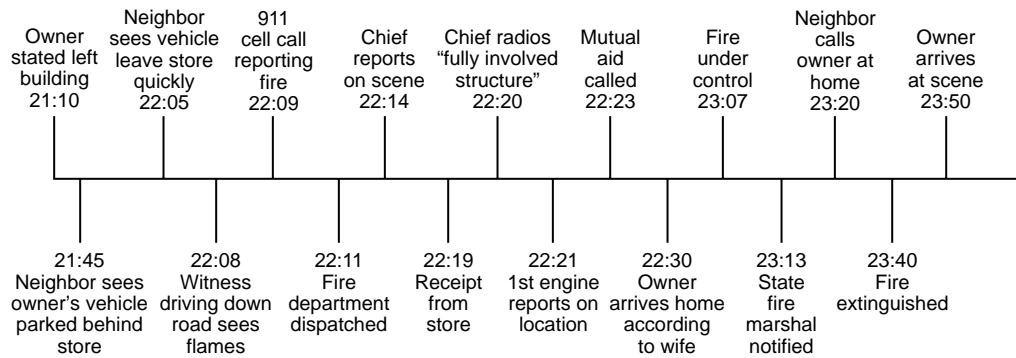
FIGURE 17.2 Illustration of a time line.

17.3 Systems Analysis. Systems analysis techniques are important tools in identifying when and how engineering analysis and modeling may be useful. These techniques, developed for use in system safety analyses, include failure modes and effects analysis, fault tree analysis, HAZOP analysis, and what-if analysis. These tools provide a systematic method for analyzing systems to determine hazards or faults. The tools can utilize either qualitative or quantitative formats. Hazard probabilities or failure rates can be factored in when using quantitative formats. Some of the more common techniques, fault tree analysis, and failure mode and effects analysis are described below. Several other systems analyses are available, each with its inherent advantages and limitations. See references for examples of methods.

17.3.1* Fault Trees. A fault tree is a logic diagram that can be used to analyze a fire or explosion event. A fault tree is developed using deductive reasoning. The diagram places, in logical sequence and position, the conditions and chains of events that are necessary for a given fire or explosion event to occur.

Fault trees can be used to test the possibility of a proposed fire cause or spread scenario and to identify or evaluate possible alternative scenarios. Fault trees are developed by breaking down an undesired event into its causal elements or component parts. The components are then placed in logical sequences of events or conditions necessary to produce the fire or explosion event, or specific aspect of associated damage, death, or injury. If the conditions are not present or if the events did not occur in the necessary sequence, then the proposed scenario is not possible. For example, if the proposed scenario required a live electrical circuit and there was no electrical service, the scenario would be incorrect unless an alternative source for the electricity could be shown. The logic for evaluating the events and conditions that control undesired events is represented by "and" decisions and "or" decisions. In a graphic representation of a fault tree, these decision points are called *gates*. In most cases, fault trees involve combinations of "and" gates and "or" gates. [See Figure 17.3.1(a).]

For an "and" controlled event to occur, all the elements and conditions must be present. An example using an "and" gate is the set of conditions that must be present for a flashlight to work and produce light. There must be good batteries; the bulb must be good; and the switch must work

to produce light. A fault tree for this process is shown in Figure 17.3.1(b).

For an "or" controlled event, any one of several series of elements and conditions may result in the subject event. An example using an "or" gate would be a flashlight that does not work when the switch is operated. The failure might be due to a switch failure, a blown bulb, or battery problems. Figure 17.3.1(c) shows the fault tree for this example.

Fault tree analysis may be used to estimate the probability of an undesired event by assigning probabilities to the conditions and events. Assigning reliable probabilities to events or conditions is often difficult and may not be possible.

All system components, their relationships, and the validity of data used need to be identified. In order to construct a fault tree properly, it may be necessary to consult people with special expertise regarding the equipment, materials, or processes involved.

The fault tree method of analysis may produce multiple feasible scenarios for a given undesirable event. As a result of insufficient data, it may not be possible to establish which scenario is most likely.

Suggested sources for data to be used in fault tree analysis include the following:

- (1) Operations and maintenance manuals
- (2) Maintenance records
- (3) Parts replacement and repair records
- (4) Design documents
- (5) Services of expert with knowledge of system
- (6) Examination and testing of exemplar equipment or materials
- (7) Component reliability databases
- (8) Building plans and specifications
- (9) Fire department reports
- (10) Incident scene documentation
- (11) Witness statements
- (12) Medical records of victims
- (13) Human behavior information

For additional guidance see Chapter 11.

Fault trees are constructed using a standard format familiar to the technical community. Software is available for assisting the user in developing and analyzing fault trees.

FIGURE 17.3.1.(a) Fault tree showing combination of “and” and “or” gates.

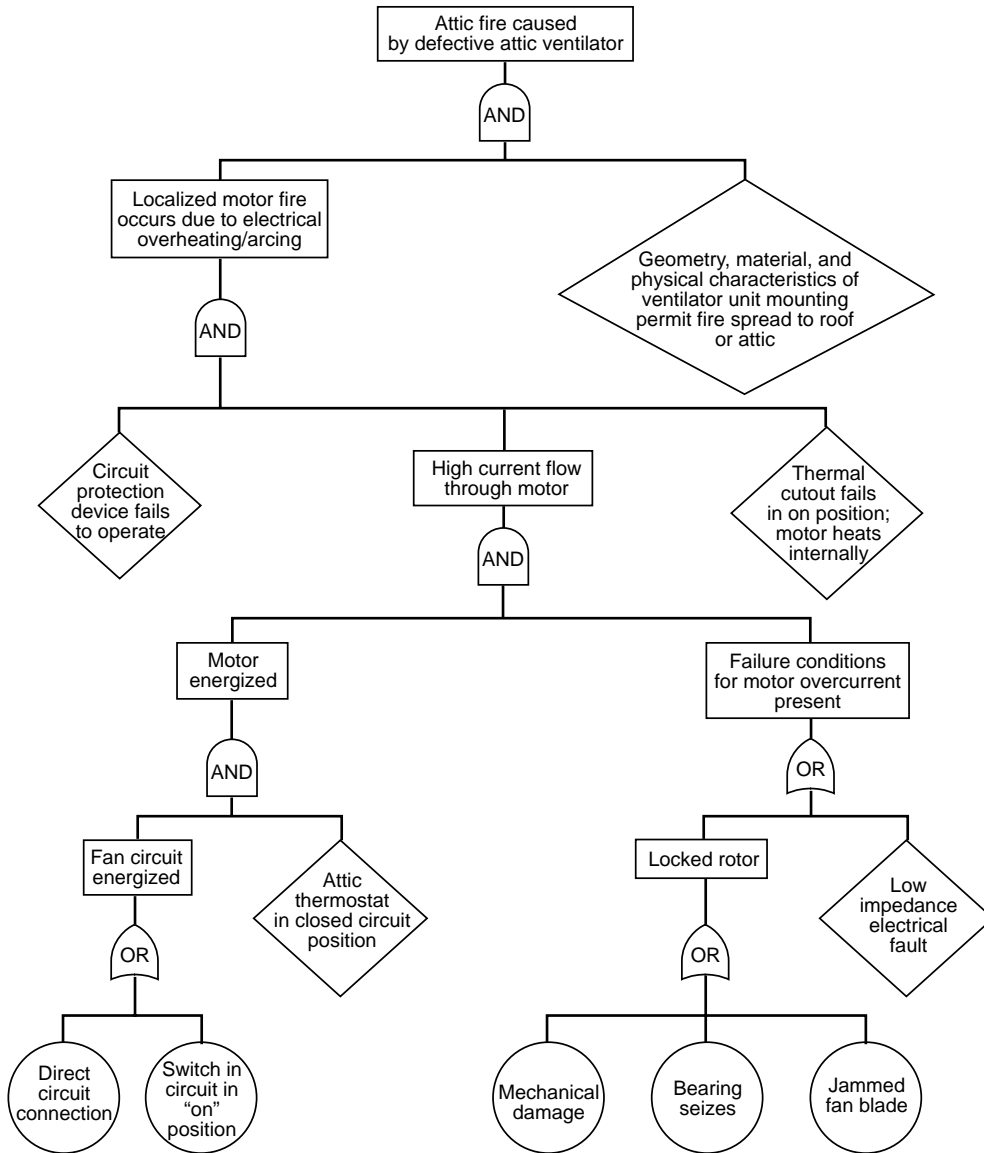

FIGURE 17.3.1(b) Example of fault tree showing “and” gate.

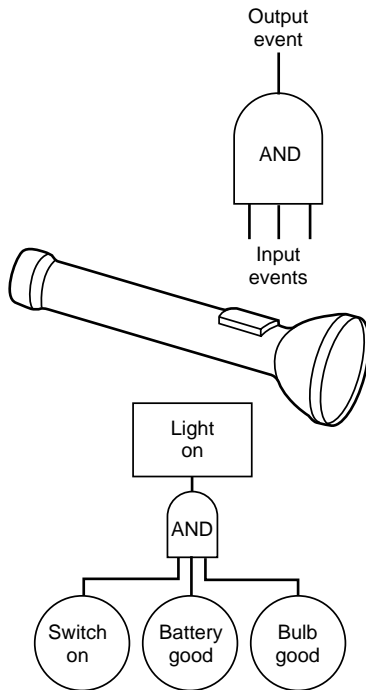
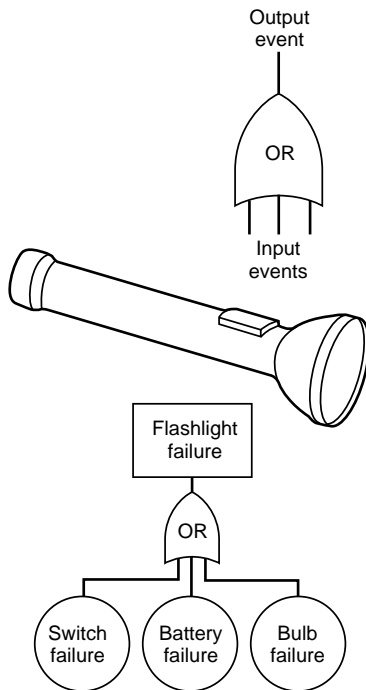

FIGURE 17.3.1(c) Example of fault tree showing “or” gate.



17.3.2 Failure Mode and Effects Analysis (FMEA). FMEA is a technique used to identify basic sources of failure within a system, and to follow the consequences of these failures in a systematic fashion. In fire/explosion investigations, FMEA is a systematic evaluation of all equipment and/or actions that could have contributed to the cause of an incident. FMEA is prepared

by filling in a table with column headings such as are shown in Figure 17.3.2. The column headings and format of the table are flexible, but at least the following three items are common:

- (1) Item (or action) being analyzed
- (2) Basic fault (failure) or error that created the hazard
- (3) Consequence of the failure

FMEA can help identify potential causes of a fire or explosion and can indicate where further analysis could be beneficial. FMEA is particularly useful in a large or complex incident. It can be effective in identifying factors, both physical and human, that could have contributed to the cause of the fire/explosion. Similarly, it can be helpful in eliminating potential causes of a fire/explosion.

Additional columns are added by the investigator as appropriate to address the needs of the particular investigation. An assessment of the likelihood of each individual failure mode is frequently included. It is helpful to assess the consequence of a given failure relative to the fire/explosion. FMEA tables can be cataloged by item and can serve as reference material for further investigations. FMEA tables can be developed using computer spreadsheets or specialized software.

When filling out the table, the investigator should consider the range of environmental conditions and the process status (i.e., normal operation, shutdown, and startup) for each item or action. Probabilities or degrees of likelihood can be assigned to each occurrence. When a sequence of failures is required for the incident to occur, the probabilities or degrees of likelihood can be combined to assess the likelihood that any given sequence of events led to the incident.

All known system components and human actions that may have contributed to the incident need to be identified. The accuracy of the determination of the sequence of the events is dependent on the accuracy assigned to each of the individual failure modes.

The data required for an FMEA depend on the extent of the analysis desired. Minimum information typically includes a list of all system components and human actions that may have led to the incident, possible failure modes for each component and action, and the immediate consequences of each failure. It is important to recognize that many system components will have more than one failure mode, so each possible failure mode and its particular consequences should be listed for each component or action.

Data for systems and components can be obtained from many sources including the following:

- (1) Operations and maintenance manuals
- (2) Maintenance records
- (3) Parts replacement and repair records
- (4) Design documents
- (5) Services of expert with knowledge of system
- (6) Examination and testing of exemplar equipment or materials
- (7) Component reliability databases
- (8) Building plans and specifications
- (9) Fire department reports
- (10) Incident scene documentation
- (11) Witness statements
- (12) Medical records of victims
- (13) Human behavior information

Table 17.3.2 shows a hypothetical example of an FMEA applied to a particular fire scenario, in the determination of a cause of that fire.

FIGURE 17.3.2 Simplified examples of failure mode and effects analysis forms.

Component	Failure mode	Direct effect	Effect on system	Hazard category	Recommended change

Component	Operating mode	Failure mode	Hazardous aspect	Failure frequency	Hazard category	Corrective action

Item	Failure mechanism	Failure rate	Possible hazard	Hazard duration	Source of data	Remarks

Table 17.3.2 Sample Failure Mode and Effects Tabulation for Lunchroom Fire

Component Item	Failure Mode	Cause of Failure	Effects of Failure	Hazard Created	Necessary Conditions	Indication of Failure	
Coffee maker	Heater current flows without shutoff	Switch left on and controls fail	"Boils" out any water in reservoir	Ignition of plastic housing	Power on	Melting of aluminum housing around heating element	
			Thermal runaway of heating element		Switch on or fails closed	Condensed aluminum at base of maker	
Range (electric)	Autoignition of cooking oil	Unattended cooking Control failure	Oil temperature raised above autoignition temperature	Burning oil fire and large amount of smoke	Thermostat fails in "on" position	Thermostat closed circuit	
					Local temperature increases above 600°C	Both thermal fuses fail to open	Both fuses closed circuit
					Unit on	Burner control in on position	
					Switch on or fails in closed position	Melted aluminum pan	
					No temperature regulation	Oil consumed or spilled on unit	
						Contacts fused or welded	

Note: The data and conclusions presented in this table are hypothetical and used for example purposes only.

17.4 Mathematical Modeling. Mathematical modeling techniques provide the investigator with tools for testing hypotheses regarding the origin and cause of the fire/explosion and the cause of the resulting damage to property or injury to people. Even when the origin and cause is not an issue, it is often possible and important to establish the cause of the resulting damage to property or injury to people.

The scope of this discussion emphasizes models and analyses that can be exercised using hand or computer-aided calculations. Usage of these analytical tools depends on the scope of the investigator's assignment, the particular incident, and the practical purpose of the investigation. A special expert may be needed to complete the analysis.

Mathematical models are intended to simulate or predict real-world phenomena using scientific principles and empirical data. There are numerous fields and specialty disciplines that use models. Some that have proven useful in fire and explosion investigations are discussed in 17.4.1 through 17.4.8.

17.4.1 Heat Transfer Analysis. Heat transfer models allow quantitative analysis of conduction, convection, and radiation in fire scenarios. These models are then used to test hypotheses regarding fire causation, fire spread, and resultant damage to property and injury to people. Heat transfer models are often incorporated into other models, including structural and fire dynamics analysis. Various general texts on heat transfer analysis are available.

Heat transfer models and analyses can be used to evaluate various hypotheses including those relating to the following:

- (1) Competency of ignition source (*See Section 16.3.*)
- (2) Damage or ignition to adjacent building
- (3) Ignition of secondary fuel items
- (4) Thermal transmission through building elements

17.4.2 Flammable Gas Concentrations. Models can be used to calculate gas concentrations as a function of time and elevation in the space and can assist in identifying ignition sources. Flammable gas concentration modeling, combined with an evaluation of explosion or fire damage and the location of possible ignition sources, can be used (a) to establish whether or not a suspected or alleged leak could have been the cause of an explosion or fire, and (b) to determine what source(s) of gas or fuel vapor were consistent with the explosion or fire scenario, damage, and possible ignition sources.

17.4.3 Hydraulic Analysis. Analysis of automatic sprinkler and water supply systems is often required in the evaluation of the cause of loss. The same mathematical models and computer codes used to design these systems can be used in loss analysis. However, the methods of application are different for design than they are for forensic analysis.

A common application of hydraulic analysis is to determine why a sprinkler system did not control a fire. Modeling can also be used to investigate the loss associated with a single sprinkler head opening, the effect of fouling in the piping, and to determine the effect of valve position on system performance at the time of loss. There are also models and methods available to analyze flow through systems other than water-based systems, such as carbon dioxide, gaseous suppression agents, dry chemicals, and fuels.

17.4.4 Thermodynamic Chemical Equilibrium Analysis. Fires and explosions believed to be caused by reactions of known or suspected chemical mixtures can be investigated by a thermodynamics analysis of the probable chemical mixtures and potential contaminants.

Thermodynamic chemical equilibrium analysis can be used to evaluate various hypotheses including those relating to the following:

- (1) Reaction(s) that could have caused the fire/explosion
- (2) Improper mixture of chemicals
- (3) Role of contamination
- (4) Role of ambient conditions
- (5) Potential of a chemical or chemical mixture to overheat
- (6) Potential for a chemical or chemical mixture to produce flammable vapors or gases
- (7) Role of human action on process failures

Thermodynamic reaction equilibrium analysis traditionally required tedious hand calculations. Currently available computer programs make this analysis much easier to perform. The computer programs typically require several material properties, including chemical formula, mass, density, entropy, and heat of formation as inputs.

Chemical reactions that are shown not to be favored by thermodynamics can be eliminated from consideration as the cause of a fire. Thermodynamically favored reactions must be further analyzed to determine whether the kinetic rate of the considered reactions is fast enough to have caused ignition, given the particular circumstances of the fire.

17.4.5 Structural Analysis. Structural analysis techniques can be utilized to determine reasons for structural failure or change during a fire or explosion. Numerous references can be found in engineering libraries, addressing matters such as strength of materials, formulas for simple structural elements, and structural analysis of assemblies.

17.4.6* Egress Analysis. The failure of occupants to escape may be one of the critical issues that an investigator needs to address. Egress models can be utilized to analyze movement of occupants under fire conditions. Integrating egress models with a fire dynamics model is often necessary to evaluate the effect of the fire environment on the occupants. See Chapter 8 on human factors.

17.4.7* Fire Dynamics Analysis. Fire dynamics analyses consist of mathematical equations derived from fundamental scientific principles or from empirical data. They range from simple algebraic equations to computer models incorporating many individual fire dynamics equations. Fire dynamics analysis can be used to predict fire phenomena and characteristics of the environment such as the following:

- (1) Time to flashover
- (2) Gas temperatures
- (3) Gas concentrations (oxygen, carbon monoxide, carbon dioxide, and others)
- (4) Smoke concentrations
- (5) Flow rates of smoke, gases, and unburned fuel
- (6) Temperatures of the walls, ceiling, and floor
- (7) Time of activation of smoke detectors, heat detectors, and sprinkler heads
- (8) Effects of opening or closing doors, breakage of windows, or other physical events

Fire dynamics analyses can be used to evaluate hypotheses regarding fire origin and fire development. The analyses use building data and fire dynamics principles and data to predict the environment created by the fire under a proposed hypothesis. The results can be compared to physical and eyewitness evidence to support or refute the hypothesis.

Building, contents, and fire dynamics data are subject to uncertainties. The effects of these uncertainties should be assessed through a sensitivity analysis and should be incorporated in hypothesis testing. Uncertainties may include the condition of openings (open or closed), the fire load characteristics, HVAC flow rates, and the heat release rate of the fuel packages. See Section 17.6 for recommended data-collection procedures.

Fire dynamics analyses can generally be classified into three categories: specialized fire dynamic analyses, zone models, and field models. They are listed in order of increasing complexity and required computational power.

(a) *Specialized Fire Dynamics Routines.* Specialized fire dynamics routines are simplified procedures designed to solve a single, narrowly focused question. In many cases, these routines can answer questions related to a fire reconstruction without the use of a fire model. Much less data is typically required for these routines than is required to run a fire model. Examples of available routines can be found in the FIREFORM section of FPETOOL.

(b) *Zone Models.* Most of the fire growth models that can be run on personal computers are zone models. Zone models usually divide each room into two spaces or zones, an upper zone that contains the hot gases produced by the fire, and a lower zone that is the source of the air for combustion. Zone sizes change during the course of the fire. The upper zone can expand to occupy virtually all the space in the room.

(c) *Field, Computational Fluid Dynamics (CFD) Models.* CFD models usually require large-capacity computer work stations or main-frame computers. By dividing the space into many small cells (frequently tens of thousands), CFD models can examine gas flows in much greater detail than zone models. Where such detail is needed, it is often necessary to use the sophistication of a field model. In general, however, field models are much more expensive to use, require more time to set up and run, and often require a high level of expertise to make the decisions required in setting up the problem and interpreting the output produced by the model. The use of CFD models in fire investigation and related litigation, however, is increasing. CFD models are particularly well suited to situations where the space or fuel configuration is irregular, where turbulence is a critical element, or where very fine detail is sought.

17.4.8 Mathematical modeling, whether simplified hand calculations or computer fire models, has inherent limitations and assumptions that should be considered. Models generally rely upon empirical data and are validated via comparison with other empirical data. Care must be taken to assure that the model is being used with due regard for limitations, assumptions, and validation.

17.5 Fire Testing.

17.5.1 Role of Fire Testing. Fire testing is a tool that can provide data that complement data collected at the fire scene (*see* 2.3.3), or can be used to test hypotheses (*see* 2.3.6). Such fire testing can range in scope from bench scale testing to full-scale recreations of the entire event. These tests may relate to the origin and cause of the fire, or to fire spread and development. The components and subsystems to be tested may include building contents, building systems, and architectural/structural elements of the building itself.)

Used as a part of data collection, fire testing can provide insights into the characteristics of fuels or items consumed in

the fire, into the characteristics of materials or assemblies affected by the fire, or into fire processes that may have played a role in the fire. This information is valuable in the analysis of data and the formation of hypotheses. (*See also Section 14.10*).

Used as a part of hypotheses testing, fire testing can assist in evaluating whether a hypothesis is consistent with the case facts and the laws of fire science. In this manner, fire testing is used in much the same way as fire modeling. In addition, fire testing may support modeling by providing input data for models or by providing benchmark data that can be used to assess the accuracy and applicability of a model.

17.5.2* Fire Test Methods. To the extent possible, fire test methods, procedures, and instrumentation should follow or be modeled after standard tests or test methods that have been reported in the fire science literature. Tests consistent with standard test methods or the fire science literature will contribute to the scientific credibility of the results. Testing not performed to a recognized standard should be consistent with the relevant facts of the case. Credible testing includes the use of materials and assemblies that are suitable exemplars of actual materials and assemblies, as well as conducting experiments that reflect the relevant conditions of the scene at the time of the fire. Valuable data may be obtained from testing that addresses limited aspects of a fire incident.

17.5.3 Limitations of Fire Testing. While fire testing can provide useful information, it is not possible to perfectly recreate all of the conditions of a specific fire that may affect the results of a full-scale test fire. Weather conditions are an example of a parameter that may not be reproduced readily and that may affect the results of a test fire. These conditions should be considered in reaching conclusions that are based on the test results.

17.6 Data Required for Modeling and Testing. Scene data required for modeling and testing, typically obtained by the fire investigator, are used to quantify or describe the scene and include structural dimensions, materials, contents, and size, location, and type of ventilation openings.

17.6.1 Structural Dimensions. Dimensions of rooms and sizes of structural components as they apply to the fire in question are required to represent the geometry of the involved compartments accurately. This information may be found in building plans, layouts, or as-built drawings. In addition to rooms or building lengths and widths, the investigator should record other dimensions such as ceiling heights, interior room dimensions, wall thickness, and floor and ceiling slopes, as shown in Figure 17.6.1.

17.6.2 Materials and Contents. A meaningful analysis of a fire requires understanding of the heat release rate, fire growth rate, and total heat released. The determination of these parameters requires identification of the types, quantities, location, and configuration of fuel actually involved in the fire. For example, a vertical configuration will burn faster than a horizontal configuration of the same fuel.

The composition, thickness, condition and layers of the materials comprising the walls, floors, windows, doors, and ceiling should be documented. The ceiling, wall, and decorative finishes, as well as the type, configuration, and condition of contents, should be documented.

FIGURE 17.6.1 Diagram of room and contents showing dimensions.

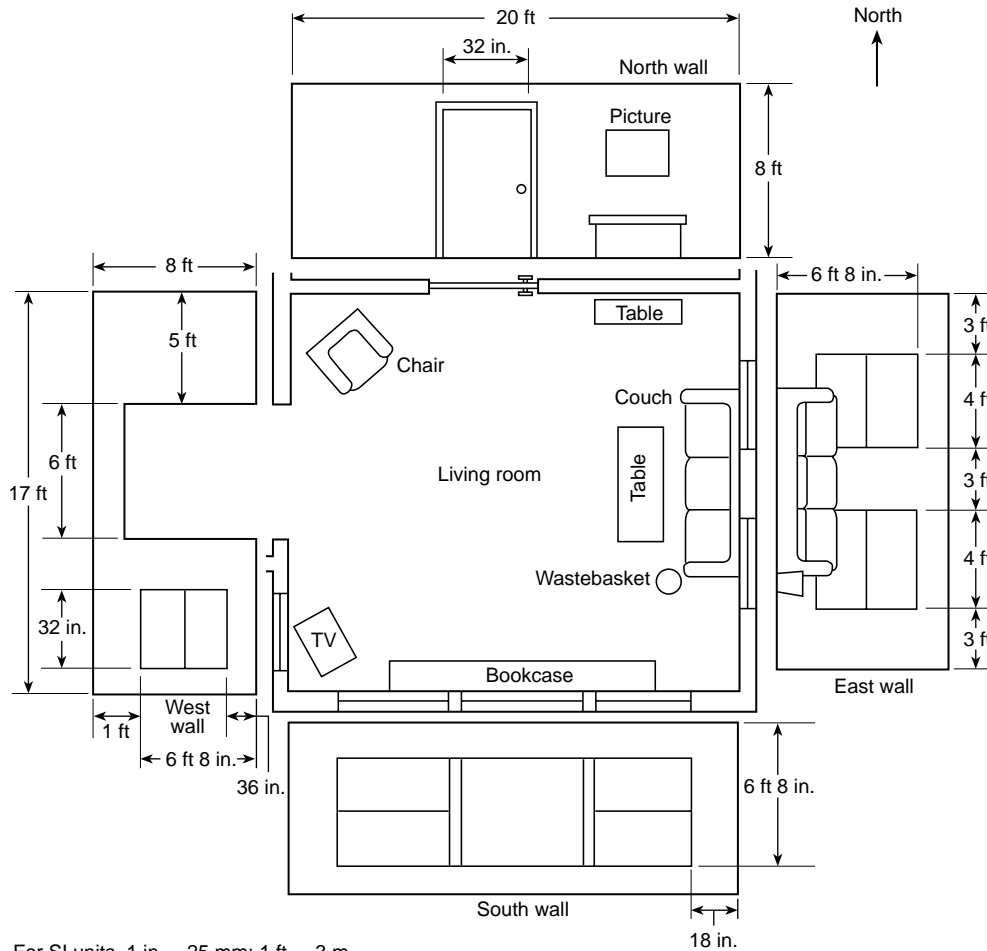

17.6.3 Ventilation. Understanding ventilation conditions is important to the validity of a fire test or model. The position and condition of doors, windows, skylights, and other sources of ventilation, such as thermostatically controlled exhaust fans, should be determined. Determining when ventilation sources were opened or closed is important. Ventilation effects may include wind, fire department ventilation, and HVAC operation and should be considered.

Chapter 18 Explosions

18.1*General. Historically, the term *explosion* has been difficult to define precisely.

The evidence that indicates an explosion occurred includes damage or change brought about by the restriction of the expanding blast pressure front as an integral element, producing physical effects on containers or nearby surfaces.

This effect can result from the confinement of the blast pressure front or the impact of an unconfined pressure or shock wave on an object, such as a person or structure.

For fire and explosion investigations, an explosion is the sudden conversion of potential energy (chemical or mechanical) into kinetic energy with the production and release of gas(es) under pressure. These high-pressure gases then do

mechanical work, such as moving, changing, or shattering nearby materials.

Although an explosion is almost always accompanied by the production of a loud noise, the noise itself is not an essential element in the definition of an explosion. The generation and violent escape of gases are the primary criteria of an explosion.

The ignition of a flammable vapor/air mixture within a can, which bursts the can or even only pops off the lid, is considered an explosion. The ignition of the same mixture in an open field, while it is a deflagration, may not be an explosion as defined in this document, even though there may be the release of high-pressure gas, a localized increase in air pressure, and a distinct noise. The failure and bursting of a tank or vessel from hydrostatic pressure of a noncompressible fluid such as water is not an explosion, because the pressure is not created by gas. Explosions are gas dynamic.

In applying this chapter, the investigator should keep in mind that there are numerous factors that control the effects of explosions and the nature of the damage produced. These factors include the type, quantity, and configuration of the fuel; the size and shape of the containment vessel or structure; the type and strength of the materials of construction of the containment vessel or structure; and the type and amount of venting present. (See Section 18.5.)

Sections of this chapter present explosion analysis techniques and terms that have been developed primarily from the

analysis of explosions involving diffuse fuel sources, such as combustible industrial and fuel gases, dusts, and the vapors from ignitable liquids in buildings of lightweight construction. The reader is cautioned that application of these principles to structures of other construction types may require additional research to other references on explosions. The analysis of explosions involving condensed-phase (solid or liquid) explosives, particularly detonating (high) explosives, may also require specialized knowledge that goes beyond the scope of this text.

18.2* Types of Explosions. There are two major types of explosions with which investigators are routinely involved: mechanical and chemical, with several subtypes within these. These types are differentiated by the source or mechanism by which the explosive pressures are produced.

18.2.1* Mechanical Explosions. Mechanical explosions are explosions in which a high-pressure gas produces a purely physical reaction. These reactions do not involve changes in the basic chemical nature of the substances in the container. A purely mechanical explosion is the rupture of a gas storage cylinder or tank under high pressure resulting in the release of the stored high-pressure gas, such as compressed air, carbon dioxide, or oxygen.

18.2.2 BLEVEs. The boiling liquid expanding vapor explosion (BLEVE) is the type of mechanical explosion that will be encountered most frequently by the fire investigator. These are explosions involving vessels that contain liquids under pressure at temperatures above their atmospheric boiling points. The liquid need not be flammable. BLEVEs are a subtype of mechanical explosions but are so common that they are treated here as a separate explosion type. A BLEVE can occur in vessels as small as disposable lighters or aerosol cans and as large as tank cars or industrial storage tanks.

A BLEVE frequently occurs when the temperature of the liquid and vapor within a confining tank or vessel is raised by an exposure fire to the point where the increasing internal pressure can no longer be contained and the vessel explodes. [See Figure 18.2.2(a).] This rupture of the confining vessel releases the pressurized liquid and allows it to vaporize almost instantaneously. If the contents are ignitable, there is almost always a fire. If the contents are noncombustible, there can still be a BLEVE, but no ignition of the vapors. Ignition usually occurs either from the original external heat that caused the BLEVE or from some electrical or friction source created by the blast or shrapnel.

FIGURE 18.2.2(a) An LP-Gas cylinder that suffered a BLEVE as a result of exposure to an external fire.



A BLEVE may also result from a reduction in the strength of a container as a result of mechanical damage or localized heating above the liquid level. This rupture of the confining

vessel releases the pressurized liquid and allows it to vaporize almost instantaneously. A common example of a BLEVE not involving an ignitable liquid is the bursting of a steam boiler. The source of overpressure is the steam created by heating and vaporizing water. When the pressure of the steam can no longer be confined by the boiler, the vessel fails and an explosion results. No chemical, combustion, or nuclear reaction is necessary. The steam under pressure is the energy source. The chemical nature of the steam (H_2O) is not changed.

BLEVEs may also result from mechanical damage, overflowing, runaway reaction, overheating vapor-space explosion, and mechanical failure. See Figure 18.2.2(b), which shows the extent of possible damage from a BLEVE.

FIGURE 18.2.2(b) A railroad tank car of butadiene that suffered a BLEVE as a result of heating created by an internal chemical reaction.



18.2.3* Chemical Explosions. In chemical explosions, the generation of high-pressure gas is the result of exothermic reactions wherein the fundamental chemical nature of the fuel is changed. Chemical reactions of the type involved in an explosion usually propagate in a reaction front away from the point of initiation.

Chemical explosions can involve solid combustibles or explosive mixtures of fuel and oxidizer, but more common to the fire investigator will be the propagating reactions involving gases, vapors, or dusts mixed with air. Such combustion reactions are called propagation reactions because they occur progressively through the reactant (fuel), with a definable flame front separating the reacted and unreacted fuel.

18.2.4 Combustion Explosions. The most common of the chemical explosions are those caused by the burning of combustible hydrocarbon fuels. These are combustion explosions and are characterized by the presence of a fuel with air as an oxidizer. A combustion explosion may also involve dusts. In combustion explosions, the elevated pressures are created by the rapid burning of the fuel and rapid production of large volumes of combustion by-products and heated gases. Because these events are likely to be encountered by the fire investigator, combustion explosions are considered here as a separate explosion type.

Combustion reactions are classified as either deflagrations or detonations, depending on the velocity of the flame front propagation through the fuel. Deflagrations are combustion reactions in which the velocity of the reaction is less than the speed of sound in the unreacted fuel medium. Detonations are combustion reactions in which the velocity of the reaction is faster than the speed of sound in the unreacted fuel medium.

Several subtypes of combustion explosions can be classified according to the types of fuels involved. The most common of these fuels are as follows:

- (1) Flammable gases
- (2) Vapors of ignitable (flammable and combustible) liquids
- (3) Combustible dusts
- (4) Smoke and flammable products of incomplete combustion (backdraft explosions)

18.2.5 Electrical Explosions. High-energy electrical arcs may generate sufficient heat to cause an explosion. The rapid heating of the surrounding gases results in a mechanical explosion that may or may not cause a fire. The clap of thunder accompanying a lightning bolt is an example of an electrical explosion effect. Electrical explosions require special expertise to investigate and are not covered in this document.

18.2.6 Nuclear Explosions. In nuclear explosions, the high pressure is created by the enormous quantities of heat produced by the fusion or fission of the nuclei of atoms. The investigation of nuclear explosions is not covered by this document.

18.3 Characterization of Explosion Damage. For descriptive and investigative purposes, it can be helpful to characterize incidents, particularly in structures, on the basis of the type of damage noted. The terms *high-order* and *low-order explosion* have been used to characterize explosion damage. The terms *high-yield* and *low-yield explosion* have also been used. Use of the terms *high-order* and *low-order damage* is recommended to reduce confusion with similar terms used to describe the energy release from explosives. (See Section 18.12.) The differences in damage are more a function of the rate of pressure rise and the strength of the confining or restricting structure than the maximum pressures being reached.

It should be recognized that the use of the terms *low-order damage* and *high-order damage* may not always be appropriate, and a site may contain evidence spanning both categories.

18.3.1 Low-Order Damage. Low-order damage is characterized by walls bulged out or laid down, virtually intact, next to the structure. Roofs may be lifted slightly and returned to their approximate original position. Windows may be dislodged, sometimes without glass being broken. Debris produced is generally large and is thrown short distances. Low-order damage is produced by slow rates of pressure rise. (See Figure 18.3.1.)

18.3.2* High-Order Damage. High-order damage is characterized by shattering of the structure, producing small, pulverized debris. Walls, roofs, and structural members are splintered or shattered, with the building completely demolished. Debris is thrown great distances, possibly hundreds of feet. High-order damage is the result of rapid rates of pressure rise. (See Figure 18.3.2.)

18.4 Effects of Explosions. An explosion is a gas dynamic phenomenon that, under ideal theoretical circumstances, will manifest itself as an expanding spherical heat and pressure wave front. The heat and pressure waves produce the damage characteristic of explosions. The effects of explosions can be observed in four major groups: blast pressure wave effect, shrapnel effect, thermal effect, and seismic effect.

18.4.1 Blast Pressure Front Effect. The explosion of a material produces a large quantity of gases. These gases expand at a high speed and move outward from the point of origin. The gases and the displaced air moved by the gases produce a pres-

sure front that is primarily responsible for the damage and injuries associated with explosions.

The blast pressure front occurs in two distinct phases, based on the direction of the forces in relation to the point of origin of the explosion. These are the positive pressure phase and negative pressure phase.

A typical pressure history from an idealized detonation, measured at a point away from the point of detonation, is shown in Figure 18.4.1 and consists of positive and negative phases. The area under the pressure-time curve is called the *impulse* of the explosion.

18.4.1.1 Positive Pressure Phase. The positive pressure phase is that portion of the blast pressure front in which the expanding gases are moving away from the point of origin. The positive pressure phase is more powerful than the negative and is responsible for the majority of pressure damage. The negative pressure phase may be undetectable by witnesses or by post-blast examination in diffuse-phase (gas/vapor) explosions.

18.4.1.2 Negative Pressure Phase. As the extremely rapid expansion of the positive pressure phase of the explosion moves outward from the origin of the explosion, it displaces, compresses, and heats the ambient surrounding air. A low air pressure condition (relative to ambient) is created at the epicenter or origin. When the positive pressure phase dissipates, air rushes back to the area of origin to equilibrate the low air pressure condition, creating the negative pressure phase.

FIGURE 18.3.1 Low-order damage in a dwelling.



FIGURE 18.3.2 High-order damage shown by shattered and splintered remains of a four-bedroom house.



FIGURE 18.4.1 Typical pressure history from an idealized detonation, measured at a point away from the point of detonation.

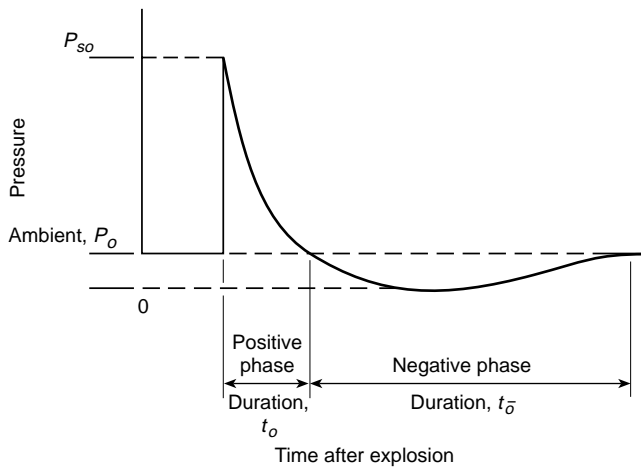

The negative pressure phase can cause secondary damage and move items of physical evidence toward the point of origin. Movement of debris during the negative pressure phase may conceal the point of origin. The negative pressure phase is usually of considerably less power than the positive pressure phase but may be of sufficient strength to cause collapse of structural features already weakened by the positive pressure phase.

18.4.1.3 Shape of Blast Front. Under ideal theoretical conditions, the shape of the blast front from an explosion would be spherical. It would expand evenly in all directions from the epicenter. In the real world, the confinement or obstruction of the blast pressure wave changes and modifies the direction, shape, and force of the front itself.

Venting of the confining vessel or structure may cause damage outside of the vessel or structure. The most damage can be expected to be in the path of the venting. For example, the blast pressure front in a room may travel through a doorway and damage items or materials directly in line with the doorway in the adjacent room. The same relative effect may be seen directly in line with the structural seam of a tank or drum that fails before the sidewalls.

The blast pressure front may also be reflected off solid obstacles and redirected, resulting in a substantial increase or possible decrease in pressure, depending on the characteristics of the obstacle struck.

After propagating reactions have consumed their available fuel, the force of the expanding blast pressure front decreases with the increase in distance from the epicenter of the explosion.

18.4.1.4 Rate of Pressure Rise versus Maximum Pressure. The type of damage caused by the blast pressure front of an explosion is dependent not only on the total amount of energy generated but also, and often to a larger degree, on the rate of energy release and the resulting rate of pressure rise.

Relatively slow rates of pressure rise will produce the pushing or bulging type of damage effects seen in low-order damage. The weaker parts of the confining structure, such as windows or structural seams, will rupture first, thereby venting the blast pressure wave and reducing the total damage effects of the explosion.

In explosions where the rate of pressure rise is very rapid, there will be more shattering of the confining vessel or con-

tainer, and debris will be thrown great distances, as the venting effects are not allowed sufficient time to develop. This is characteristic of high-order damage.

Where the pressure rise is less rapid, the venting effect will have an important impact on the maximum pressure developed. (See NFPA 68, *Guide for Venting of Deflagrations*, for equations, data, and guidance on calculating the theoretical effect of venting on pressure during a deflagration.) Such calculations assume a structure or vessel that can sustain such a high pressure. The maximum theoretical pressure developable by a deflagration can, under some circumstances, be as high as 7 to 9 atmospheres [in the range of 120 psi (827 kPa)]. In commonly encountered situations, such as fugitive gas explosions in residential or commercial buildings, the maximum pressure will be limited to a level slightly higher than the pressure that major elements of the building enclosure (e.g., walls, roof, and large windows) can sustain without rupture. In a well-built residence, this pressure will seldom exceed 3 psi (21 kPa).

18.4.2 Shrapnel Effect. When the containers, structures, or vessels that contain or restrict the blast pressure fronts are ruptured, they are often broken into pieces that may be thrown over great distances. These pieces of debris are called shrapnel or missiles. They can cause great damage and personal injury, often far from the source of the explosion. In addition, shrapnel can often sever electric utility lines, fuel gas or other flammable fuel lines, or storage containers, thereby adding to the size and intensity of postexplosion fires or causing additional explosions.

The distance to which missiles can be propelled outward from an explosion depends greatly on their initial direction. Other factors include their weight and aerodynamic characteristics. An idealized diagram for missile trajectories is shown in Figure 18.4.2 for several different initial directions. The actual distances that missiles can travel depend greatly on aerodynamic conditions and occurrences of ricochet impacts.

FIGURE 18.4.2 Idealized missile trajectories for several initial flight directions.

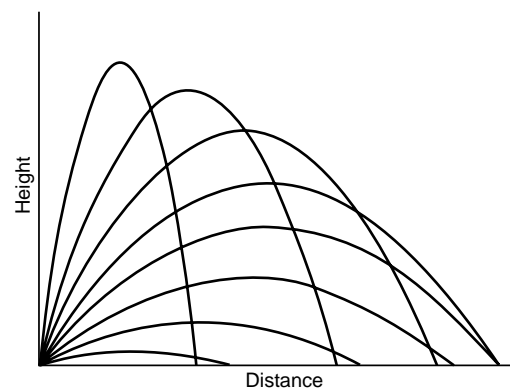

18.4.3 Thermal Effect. Combustion explosions release quantities of energy that heat combustion gases and ambient air to high temperatures. This energy can ignite nearby combustibles or can cause burn injuries to anyone nearby. These secondary fires increase the damage and injury from the explosion and complicate the investigation process. Often, it is difficult to determine which occurred first, the fire or the explosion.

All chemical explosions produce great quantities of heat. The thermal damage (*see effective temperature in 4.8.1*) depends on the nature of the explosive fuel as well as the duration of the high temperatures. Detonating explosions produce

extremely high temperatures of very limited duration, whereas deflagration explosions produce lower temperatures, but for much longer periods.

Fireballs and firebrands are possible thermal effects of explosions, particularly BLEVEs involving flammable vapors. Fireballs are the momentary ball of flame present during or after the explosive event. High-intensity, short-duration thermal radiation may be present with a fireball. Firebrands are hot or burning fragments propelled from the explosion. All these effects may serve to initiate fires away from the center of the explosion.

18.4.4 Seismic Effect. As the blast pressure wave expands, and as the damaged portions of large structures are knocked to the ground, significant localized seismic or earth tremors can be transmitted through the ground. These seismic effects, usually negligible for small explosions, can produce additional damage to structures and underground utility services, pipelines, tanks, or cables.

18.5 Factors Controlling Explosion Effects. Factors that can control the effects of explosions include the type and configuration of the fuel; nature, size, volume, and shape of any containment vessel or object affected; location and magnitude of ignition source; venting of the containment vessel; relative maximum pressure; and rate of pressure rise. The nature of these factors and their various combinations in any one explosion incident can produce a wide variety of physical effects with which the investigator will be confronted.

Various phenomena affect the characteristics of a blast pressure front as it travels away from the source. These phenomena are described in 18.5.1 and 18.5.2.

18.5.1 Blast Pressure Front Modification by Reflection. As a blast pressure front encounters objects in its path, the blast pressure front may amplify due to its reflection. This reflection in some cases will cause the overpressure to increase and will sometimes amplify it as much as eight times at the surface of reflection, depending on the angle of incidence. This effect is negligible with deflagrations, where the pressure in an entire vessel equalizes at approximately the speed of sound in air (i.e., a strong shock wave is not present).

18.5.2 Blast Pressure Front Modification by Refraction and Blast Focusing. Atmospheric inhomogeneities can cause non-ideal blast pressure front behavior at times. When a blast pressure front encounters a layer of air at a significantly different temperature, it may cause it to bend, or refract. This occurs because the speed of sound is proportional to the square root of temperature in air. A low-level temperature inversion can cause an initially hemispherical blast front to refract and to focus on the ground around the center of the explosion. Severe weather-related wind shear can cause focusing in the downwind direction. This effect is negligible with deflagrations.

18.6 Seated Explosions. The *seat* of an explosion is defined as the crater or area of greatest damage, located at the point of initiation (epicenter) of an explosion. Material may be thrown out of the crater. This material is called *ejecta* and may range from large rocks to fine dust. The presence of a seat indicates the explosion of a concentrated fuel source in contact with or in close proximity to the seat.

These seats can be of any size, depending on the size and strength of the explosive material involved. They typically range in size from a few inches (cm) to 25 ft (7.6 m) in diameter. They display an easily recognizable crater of pulverized soil, floors, or walls located at the center of otherwise less dam-

aged areas. Seated explosions are generally characterized by high pressure and rapid rates of pressure rise.

Only specific types or configurations of explosive fuels can produce seated explosions. These include explosives, steam boilers, tightly confined fuel gases or liquid fuel vapors, and BLEVEs occurring in relatively small containers, such as cans or barrels.

In general, it is accepted that explosive velocities should exceed the speed of sound (detonations) to produce seated explosions, unless the damage is produced by shrapnel from a failing vessel.

18.6.1 Explosives. Explosions fueled by many explosives are most easily identified by their highly centralized epicenters, or seats. High explosives especially produce such high-velocity, positive pressure phases at detonation that they often shatter their immediate surroundings and produce craters or highly localized areas of great damage.

18.6.2 Boiler and Pressure Vessels. A boiler explosion often creates a seated explosion because of its high energy, rapid rate of pressure release, and confined area of origin.

Boiler and pressure vessel explosions will exhibit effects similar to explosives, though with lesser localized overpressure near the source.

Each of these explosions involves a rapid release of energy from a containment vessel, resulting in a pressure wave that decays with distance.

18.6.3 Confined Fuel Gas and Liquid Vapor. Fuel gases or ignitable liquid vapors — when confined to such small vessels as tanks, barrels, or other containers — can also produce seated explosions.

18.6.4 BLEVE. A boiling liquid expanding vapor explosion will produce a seated explosion if the confining vessel (e.g., a barrel or small tank) is of a small size and if the rate of pressure release when the vessel fails is rapid enough.

18.7 Nonseated Explosions. Nonseated explosions occur most often when the fuels are dispersed or diffused at the time of the explosion because the rates of pressure rise are moderate and because the explosive velocities are subsonic. It should be kept in mind that even supersonic detonations may produce nonseated explosions under certain conditions.

18.7.1 Fuel Gases. Fuel gases, such as natural gas and liquefied petroleum (LP) gases, most often produce nonseated explosions. This is because these gases often are confined in large containers, such as individual rooms or structures, and their explosive speeds are subsonic.

18.7.2 Pooled Flammable/Combustible Liquids. Explosions from the vapors of pooled flammable or combustible liquids are nonseated explosions. The large areas that they cover and their subsonic explosive speeds preclude the production of small, high-damage seats.

18.7.3* Dusts. Although dust explosions are often among the most violent and damaging of explosions, they most often occur in confined areas of relatively wide dispersal, such as grain elevators, materials-processing plants, and coal mines. These large areas of origin preclude the production of pronounced seats.

18.7.4 Backdraft or Smoke Explosion. Backdraft or smoke explosions almost always involve a widely diffused volume of combustible gases and particulate matter. Their explosive velocities are subsonic, thereby precluding the production of pronounced seats.

Table 18.8 Combustion Properties of Common Flammable Gases

Gas	Btu per ft ³ (gross)	MJ/m ³ (gross)	Limits of Flammability Percent by Volume in Air		Specific Gravity (air = 1.0)	Air Needed to Burn 1 ft ³ of Gas in ft ³	Air Needed to Burn 1 m ³ of Gas in m ³	Ignition Temp	
			Lower	Upper				°F	°C
Natural gas									
High inert type ^a	958-1051	35.7-39.2	4.5	14.0	0.660-0.708	9.2	9.2	—	—
High methane type ^b	1008-1071	37.6-39.9	4.7	15.0	0.590-0.614	10.2	10.2	900-1170	482-632
High Btu type ^c	1071-1124	39.9-41.9	4.7	14.5	0.620-0.719	9.4	9.4	—	—
Blast furnace gas	81-111	3.0-4.1	33.2	71.3	1.04-1.00	0.8	0.8	—	—
Coke oven gas	575	21.4	4.4	34.0	0.38	4.7	4.7	—	—
Propane (commercial)	2516	93.7	2.15	9.6	1.52	24.0	24.0	920-1120	493-604
Butane (commercial)	3300	122.9	1.9	8.5	2.0	31.0	31.0	900-1000	482-538
Sewage gas	670	24.9	6.0	17.0	0.79	6.5	6.5	—	—
Acetylene	1499	208.1	2.5	81.0	0.91	11.9	11.9	581	305
Hydrogen	325	12.1	4.0	75.0	0.07	2.4	2.4	932	500
Anhydrous ammonia	386	14.4	16.0	25.0	0.60	8.3	8.3	1204	651
Carbon monoxide	314	11.7	12.5	74.0	0.97	2.4	2.4	1128	609
Ethylene	1600	59.6	2.7	36.0	0.98	14.3	14.3	914	490
Methyl acetylene, propadiene, stabilized ^d	2450	91.3	3.4	10.8	1.48	—	—	850	454

^aTypical composition CH₄ 71.9-83.2%; N₂ 6.3-16.20%.

^bTypical composition CH₄ 87.6-95.7%; N₂ 0.1-2.39%.

^cTypical composition CH₄ 85.0-90.1%; N₂ 1.2-7.5%.

^dMAPP® Gas from the NFPA *Fire Protection Handbook*, 17th ed., Table 3.7C.

18.8 Gas/Vapor Explosions. The most commonly encountered explosions are those involving gases or vapors, especially fuel gases or the vapors of ignitable liquids. Violent explosions can be encountered with lighter-than-air gases, such as natural gas, but are reported less frequently than with gases or vapors having vapor densities higher than 1.0 (heavier than air). Table 18.8 provides some useful properties of common flammable gases. NFPA 68, *Guide for Venting of Deflagrations*, provides a more complete introduction to the fundamentals of these explosions.

18.8.1* Minimum Ignition Energy for Gases and Vapors. Gaseous fuel-air mixtures are the most easily ignitable fuels capable of causing an explosion. Ignition temperatures in the 700°F to 1100°F (370°C to 590°C) range are common. Minimum ignition energies begin at approximately 0.25 millijoules.

18.8.2 Interpretation of Explosion Damage. The explosion damage to structures (low-order and high-order) is related to a number of factors. These include the fuel-air ratio, vapor density of the fuel, turbulence effects, volume of the confining space, location and magnitude of the ignition source, venting, and the characteristic strength of the structure.

18.8.2.1* Fuel-Air Ratio. Often the nature of damage to the confining structure can be an indicator of the fuel-air mixture at the time of ignition.

Some fire investigation literature has indicated that an entire volume should be occupied by a flammable mixture of gas and air for there to be an explosion. This is not the case, because relatively small volumes of explosive mixtures capable of causing damage may result from gases or vapors collecting in a given area. (*See 18.8.2.2.*)

Explosions that occur in mixtures at or near the lower explosive limit (LEL) or upper explosive limit (UEL) of a gas or vapor produce less violent explosions than those near the optimum concentration (i.e., usually just slightly rich of stoichiometric). This is because the less-than-optimum ratio of fuel and air results in lower flame speeds and lower maximum pressures. In general, these explosions tend to push and heave at the confining structure, producing low-order damage.

The flame speed is the local velocity of a freely propagating flame relative to a fixed point. It is the sum of the burning velocity and the translational velocity of the flame front. The maximum laminar flame speeds for methane and propane are 11.5 ft/s (3.5 m/s) and 13.1 ft/s (4 m/s), respectively.

The burning velocity is the rate of flame propagation relative to the velocity of the unburned gas ahead of it. The fundamental burning velocity is the burning velocity for laminar flame under stated conditions of composition, temperature, and pressure of the unburned gas. Fundamental burning velocity is an inherent characteristic of a combustible and is a fixed value, whereas flame speed can vary widely, depending on the existing parameters of temperature, pressure, confining volume and configuration, combustible concentration, and turbulence.

The burning velocity is the velocity at which a flame reaction front moves into the unburned mixture as it chemically transforms the fuel and oxidant into combustion products. It is only a fraction of the flame speed. The transitional velocity is the sum of the velocity of the flame front caused by the volume expansion of the combustion products due to the increase in temperature and any increase in the number of moles and any flow velocity due to motion of the gas mixture prior to ignition. The burning velocity of the flame front can be calculated from the fundamental burning velocity, which is reported in NFPA 68, *Guide for Venting of Deflagrations*, at standardized conditions of temperature, pressure, and composition of unburned gas. As pressure and turbulence increase substantially during an explosion, the fundamental burning velocity will increase, further accelerating the rate of pressure increase. NFPA 68 lists data on the various materials.

Explosions of mixtures near the LEL do not tend to produce large quantities of postexplosion fire, as nearly all of the available fuel is consumed during the explosive propagation.

Explosions of mixtures near the UEL tend to produce postexplosion fires because of the fuel-rich mixtures. The delayed combustion of the remaining fuel produces the postexplosion fire. Often, a portion of the mixture over the UEL has fuel that does not burn until it is mixed with air during the explosion's venting phase or negative pressure phase, thereby producing the characteristic following fire.

When optimum (i.e., most violent) explosions occur, it is almost always at mixtures near or just above the stoichiometric mixture (i.e., slightly fuel rich). This is the optimum mixture. These mixtures produce the most efficient combustion and, therefore, the highest flame speeds, rates of pressure rise, maximum pressures, and consequently the most damage. Postexplosion fires can occur if there are pockets of overly rich mixture.

For common lighter-than-air gases in residential buildings, an explosion involving an optimum concentration will sometimes result in some destructive shattering effects of wooden structural materials.

18.8.2.2* Vapor Density. The vapor density of the gas or vapor fuel can have a marked effect on the nature of the explosion damage to the confining structure. This is especially true in dwellings and other buildings. While air movement from both natural and forced convection is the dominant mechanism for moving gases in a structure, the vapor density can affect the movement of a gas or vapor as it escapes from its container or pipeline.

While a gas leak is in progress, heavier-than-air gases and vapors (i.e., vapor density greater than 1.0), such as from ignitable liquids and LP-Gases, tend to flow to lower areas. Lighter-than-air gases, such as natural gas, tend to rise and flow to upper areas. For example, signs of postblast burning in pocketed areas between ceiling joists may be indicative of a lighter-than-air fuel rather than heavier-than-air gases or vapors. (See 4.17.9.) Due to their higher mobility and tendency to escape upward, lighter-than-air gases are less likely to produce hazardous situations than heavier-than-air gases, which can flow into basements, crawl spaces, wells, and tanks.

A natural gas leak in the first story of a multistory structure may well be manifested in an explosion with an epicenter in an upper story. The natural gas, being lighter than air, will have a tendency to rise through natural openings and may even migrate inside walls. The gas will continue to disperse in the structure until an ignition source is encountered.

An LP-Gas leak on the first story of a house, if it is not ignited there, can travel away from the source and, due to its density, will tend to migrate downward. During the leak and for some time thereafter, the gas may be at a higher concentration in low areas.

Ignition of the gas will occur only if the concentration is within the flammable limits and in contact with a competent ignition source (one with enough energy).

Whether lighter- or heavier-than-air gases are involved, there may be evidence of the passage of flame where the fuel air layer was. Scorching, blistering of paintwork, and showing of "tidemarks" are indicators of this type of phenomena. The operation of heating and air-conditioning systems, temperature gradients, and the effects of wind on a building can cause mixing and movement that can reduce the effects of vapor density. Vapor density effects are greatest in still-air conditions.

Full-scale testing of the distribution of flammable gas concentrations in rooms has shown that near stoichiometric concentrations of gas will develop between the location of the leak and either (1) the ceiling for lighter-than-air gases or (2) the floor for heavier-than-air gases. It was also reported that a heavier-than-air gas that leaked at floor level will create a greater concentration at floor level and that the gas will slowly diffuse upward. A similar but inverse relationship is true for a lighter-than-air gas leaked at ceiling height. Ventilation, both natural and mechanical, can change the movement and mixing of the gas and can result in gas spreading to adjacent rooms.

The vapor density of the fuel is not necessarily indicated by the relative elevation of the structural explosion damage above floor level. It was once widely thought that if the walls of a particular structure were blown out at floor level, the fuel gas would be heavier than air, and, conversely, if the walls were blown out at ceiling level, the fuel would be lighter than air. Since explosive pressure within a room equilibrates at the speed of sound, a wall will experience a similar pressure-time history across its entire height. The level of the explosion damage within a conventional room is a function of the construction strength of the wall headers and bottom plates, the least resistive giving way first.

18.8.2.3 Turbulence. Turbulence within a fuel-air mixture increases the flame speed and, therefore, greatly increases the rate of combustion and the rate of pressure rise. Turbulence can produce rates of pressure rise with relatively small amounts of fuel that can result in high-order damage even though there may have only been a lean limit [i.e., lower flammable limit (LFL)] mixture present. The shape and size of the confining vessel can have a profound effect on the severity of the explosion by affecting the nature of turbulence. The presence of many obstacles in the path of the combustion wave has been shown to increase turbulence and greatly increase the severity of the explosion, mainly due to increasing the flame speed of the mixture involved. Other mixing and turbulence sources, such as fans and forced-air ventilation, may increase the explosion effects.

18.8.2.4* Nature of Confining Space. The nature of containment, its size, shape, construction, volume, materials, and design, will also greatly change the effects of the explosion. For example, a specific percentage by volume of natural gas mixed with air will produce completely different effects if it is contained in a 1000 ft³ (28.3 m³) room than if it is contained

in a 10,000 ft³ (283.2 m³) room at the time of ignition. This is true even though the velocity of the flame front and the maximum overpressure achieved will be essentially the same.

A long, narrow corridor filled with a combustible vapor/air mixture, when ignited at one end, will be very different in its pressure distribution, rate of pressure rise, and its effects on the structure than if the same volume of fuel-air were ignited in a cubical compartment.

In general, the smaller the volume of the vessel, the higher the rate of pressure rise for a given fuel-air mixture, and the more violent the explosion.

During the explosion, turbulence caused by obstructions within the containment vessel can increase the damage effects. This turbulence can be caused by solid obstructions, such as columns or posts, machinery, or wall partitions, which increase flame speed, and thus increase the rate of pressure rise.

18.8.2.5* Location and Magnitude of Ignition Source. The highest rate of pressure rise will occur if the ignition source is in the center of the confining structure. The closer the ignition source is to the walls of the confining vessel or structure, the sooner the flame front will reach the wall and be cooled by heat transfer to the walls. The result is a loss of energy and a corresponding lower rate of pressure rise and a less violent explosion. The energy of the ignition source generally has a minimal effect on the course of an explosion, but unusually large ignition sources (e.g., blasting caps or explosive devices) can significantly increase the speed of pressure development and, in some instances, can cause a deflagration to transition into a detonation.

18.8.2.6 Venting. With gas, vapor-, or dust-fueled explosions, the venting of the containment vessel will also have a profound effect on the nature of explosion damage. For example, it is possible to cause a length of steel pipe to burst in the center if it is sufficiently long, in spite of the fact that it may be open at both ends. The number, size, and location of doors and windows in a room may determine whether the room experiences complete destruction or merely a slight movement of the walls and ceiling.

Venting of a confining vessel or structure may also cause damage outside of the vessel or structure. The most damage can be expected in the path of venting. For example, the blast pressure front in a room may travel through a doorway and may damage items or materials directly in line with the doorway in the adjacent room. The same relative effect may be seen directly in line with the structural seam of a tank or drum that fails before the sidewalls.

With detonations, venting effects are minimal, as the high speeds of the blast pressure fronts are too fast for any venting to relieve the pressures.

18.8.3 Underground Migration of Fuel Gases. It is quite common for fuel gases that have leaked from underground piping systems to migrate underground, enter structures, and fuel fires or explosions there. Because the soil surrounding underground pipes and utility lines has been more disturbed than adjacent soil, it is generally less dense and more porous. Both lighter-than-air and heavier-than-air fugitive fuel gases will tend to follow the exterior of such underground constructions and can enter structures in this manner. Often these fugitive gases will permeate the soil, migrate upward, and dissipate harmlessly onto the air. However, if the surface of the ground is then obstructed by rain, snow, freezing, or new paving, the gases may migrate laterally and enter structures.

Fuel gases migrating underground have been known to enter buildings by seeping into sewer lines, underground electrical or telephone conduits, drain tiles, or even directly

through basement and foundation walls, none of which is as gastight as water or gas lines.

In addition, gases can move through underground conduits for hundreds of feet and then fuel explosions or fires in distant structures. (See 7.9.7.)

Natural gas and propane have little or no natural odors of their own. In order for them to be readily detected when leaking, foul smelling malodorant compounds are added to the gases. Odorant verification should be a part of any explosion investigation involving or potentially involving fuel gas, especially if it appears that there were no indications of a leaking gas being detected by people present. The odorant's presence, in the proper amount, should be verified. (See 7.2.4.)

18.8.4* Multiple Explosions. A migration and pocketing effect is also often manifested by the production of multiple explosions, generally referred to as *secondary explosions* (and sometimes *cascade explosions*). Gas and vapors that have migrated to adjacent stories or rooms can collect or pocket on each level. When an ignition and explosion takes place in one story or room, subsequent explosions can occur in adjoining areas or stories.

The migration and pocketing of gases often produces areas or pockets with different air-fuel mixtures. One pocket could be within the explosive range of the fuel, while a pocket in an adjoining room or story could be over the upper explosive limit (UEL). When the first mixture is ignited and explodes, damaging the structure, the dynamic forces of the explosion, including the positive and negative pressure phases, tend to mix air into the fuel-rich mixture and bring it into the explosive range. This mixture in turn will explode if an ignition source of sufficient energy is present. In this way, a series of vapor/gas explosions is possible.

Multiple explosions are a very common occurrence. However, often the explosions occur so rapidly that witnesses report hearing only one, but the physical evidence, including multiple epicenters, indicates more than one explosion.

A secondary or cascade explosion into an adjacent compartment can be more violent than the primary explosion in certain situations. This violence is generally due to the first explosion acting as a very strong ignition source, creating additional turbulence and possible precompression in the compartment.

18.9 Dust Explosions. Finely divided solid materials (e.g., dusts and fines), when dispersed in the air, can fuel particularly violent and destructive explosions. Even materials that are not normally considered to be combustible, such as aspirin, aluminum, or milk powders, can produce explosions when burned as dispersed dusts.

Dust explosions occur in a wide variety of materials: agricultural products, such as grain dusts and sawdust; carbonaceous materials, such as coal and charcoal; chemicals; drugs, such as aspirin and ascorbic acid (i.e., vitamin C); dyes and pigments; metals, such as aluminum, magnesium, and titanium; plastics; and resins, such as synthetic rubber.

NFPA 68, *Guide for Venting of Deflagrations*, provides a more complete introduction to fundamentals of dust explosions.

18.9.1* Particle Size. Since the combustion reaction takes place at the surface of the dust particle, the rates of pressure rise generated by combustion are largely dependent on the surface area of the dispersed dust particles. For a given mass of dust material, the total surface area, and consequently the violence of the explosion, increases as the particle size decreases. The finer the dust, the more violent is the explosion. In general, an explosion hazard concentration of combustible dusts can exist when the particles are 420 microns or less in diameter.

18.9.2* Concentration. The concentration of the dust in air has a profound effect on its ignitability and violence of the blast pressure wave. As with ignitable vapors and gases, there are minimum explosive concentrations of specific dusts required for a propagating combustion reaction to occur. Minimum concentrations can vary with the specific dust from as low as 0.015 oz/ft³ to 2.0 oz/ft³ (20 g/m³ to 2000 g/m³) with the most common concentrations being less than 1.0 oz/ft³ (1000 g/m³).

Unlike most gases and vapors, however, there is generally no reliable maximum limit of concentration. The reaction rate is controlled more by the surface-area-to-mass ratio than by a maximum concentration.

Similar to gases and vapors, the rate of pressure rise and the maximum pressure that occur in the dust explosion are higher if the pre-explosion dust concentration is at or close to the optimum mixture. The combustion rate and maximum pressure decrease if the mixture is fuel rich or fuel lean. The rate of pressure rise and total explosion pressure are very low at the lower explosive limit and at very high fuel-rich concentrations.

18.9.3 Turbulence in Dust Explosions. Turbulence within the suspended dust-air mixture greatly increases the rate of combustion and thereby the rate of pressure rise. The shape and size of the confining vessel can have a profound effect on the severity of the dust explosion by affecting the nature of turbulence. An example is the pouring of grain from a great height into a largely empty storage bin.

18.9.4* Moisture. Generally, increasing the moisture content of the dust particles increases the minimum energy required for ignition and the ignition temperature of the dust suspension. The initial increase in ignition energy and temperature is generally low, but, as the limiting value of moisture concentration is approached, the rate of increase in ignition energy and temperature becomes high. Above the limiting values of moisture, suspensions of the dust will not ignite. The moisture content of the surrounding air, however, has little effect on the propagation reaction once ignition has occurred.

18.9.5 Minimum Ignition Energy for Dust. Dust explosions have been ignited by open flames, smoking materials, lightbulb filaments, welding and cutting, electric arcs, static electric discharges, friction sparks, heated surfaces, and spontaneous heating.

Ignition temperatures for most material dusts range from 600°F to 1100°F (320°C to 590°C). Layered dusts generally have lower ignition temperatures than the same dusts suspended in air. Minimum ignition energies are higher for dusts than for gas or vapor fuels and generally fall within the range of 10 to 40 millijoules, higher than most flammable gases or vapors.

18.9.6 Multiple Explosions. Dust explosions in industrial scenarios usually occur in a series. The initial ignition and explosion are most often less severe than subsequent secondary explosions. However, the first explosion puts additional dust into suspension, which results in additional explosions. The mechanism for this is that structural vibrations and the blast front from one explosion will propagate faster than the flame front, lofting dust ahead of it and entraining it in the air. In facilities such as grain elevators, these secondary explosions often progress from one area to another, or from building to building.

18.10 Backdraft or Smoke Explosions. When fires occur within rooms or structures that are relatively airtight, it is common for fires to become oxygen depleted. In these cases, high concentrations of heated airborne particulates and aerosols, carbon monoxide, and other flammable gases can be generated due to incomplete combustion. These heated fuels will collect in

a structure where there is insufficient oxygen to allow combustion to occur and insufficient ventilation to allow them to escape.

When this accumulation of fuels mixes with air, such as by the opening of a window or door, they can ignite and burn sufficiently fast to produce low-order damage, though usually with less than 2 psi (13.8 kPa) overpressure in conventional structures. These are called *backdrafts* and *smoke explosions*.

18.11 Outdoor Vapor Cloud Explosions. An outdoor vapor cloud explosion is the result of the release of gas, vapor, or mist into the atmosphere, forming a cloud within the fuel's flammable limits and causing subsequent ignition. The principal characteristic of the event is potentially damaging pressures within and beyond the boundary of the cloud due to deflagration or detonation phenomena.

This phenomenon also has been referred to as an *unconfined vapor air explosion* or *unconfined vapor cloud explosion*. While completely unconfined, vapor cloud explosions are possible. Most involve at least some partial restriction of pressure by manmade or natural structures.

Outdoor vapor cloud explosions have generally occurred at process plants and in flammable liquid or flammable gas storage areas or have involved large transport vehicles (e.g., railroad tank cars). Large amounts of fuel (hundreds of pounds or more) are generally involved.

18.12* Explosives. Explosives are any chemical compound, mixture, or device, the primary purpose of which is to function by explosion. Explosives are categorized into two main types: low explosives and high explosives (not to be confused with low-order and high-order damage).

18.12.1 Low Explosives. Low explosives are characterized by deflagration (subsonic blast pressure wave) or a relatively slow rate of reaction and the development of low pressure when initiated. Common low explosives are smokeless gunpowder, flash powders, solid rocket fuels, and black powder. Low explosives are designed to work by the pushing or heaving effects of the rapidly produced hot reaction gases.

It should be noted that some low explosives (i.e., double-base smokeless powder) can achieve detonation under circumstances where confinement is adequate to produce sufficient reaction speed, where the ignition source is very strong, or where instabilities in combustion occur.

18.12.2 High Explosives. High explosives are characterized by a detonation propagation mechanism. Common high explosives are dynamites, water gel, TNT, ANFO, RDX, and PETN. High explosives are designed to produce shattering effects by virtue of their high rate-of-pressure rise and extremely high detonation pressure [on the order of 1,000,000 psi (6,900,000 kPa)]. These high, localized pressures are responsible for cratering and localized damage near the center of the explosion.

The effects produced by diffuse phase (i.e., fuel-air) explosions and solid explosives are very different. In a diffuse phase explosion (usually deflagration), structural damage will tend to be uniform and omnidirectional, and there will be relatively widespread evidence of burning, scorching, and blistering. In contrast, the rate of combustion of a solid explosive is extremely fast in comparison to the speed of sound. Therefore, pressure does not equalize through the explosion volume and extremely high pressures are generated near the explosive. The pressure and the resultant level of damage rapidly decay with distance away from the center of the explosion. At the location of the explosion, there should be evidence of crushing, splintering,

and shattering effects produced by the higher pressures. Away from the source of the explosion, there is usually very little evidence of intense burning or scorching, except where hot shrapnel or firebrands have landed on combustible materials.

18.12.3 Investigation of Explosive Incidents. The investigation of incidents involving explosives requires very specialized training. Explosives are strictly regulated by local and federal laws, so most explosives incidents will be investigated by law enforcement or regulatory agencies. It is suggested that only investigators with the appropriate training endeavor to conduct such investigations. Those without this training should contact law enforcement or other agencies for assistance.

18.13 Investigating the Explosion Scene. The objectives of the explosion scene investigation are no different from those for a regular fire investigation: determine the origin, identify the fuel and ignition source, determine the cause, and establish the responsibility for the incident. A systematic approach to the scene examination is equally or even more important in an explosion investigation than in a fire investigation. Explosion scenes are often larger and more disturbed than fire scenes. Without a pre-planned, systematic approach, explosion investigations become even more difficult or impossible to conduct effectively.

Typical explosion incidents can range from a small pipe bomb in a dwelling to a large process explosion encompassing an entire facility. While the investigative procedures described in 18.13.1 through 18.13.3 are more comprehensive for the large incidents, the same principles should be applied to small incidents, with appropriate simplification.

When damage is very extensive and includes much structural damage, an explosion dynamics expert and a structural expert should be consulted early in the investigation to aid in the complex issues involved.

18.13.1 Securing the Scene. The first duty of the investigator is to secure the scene of the explosion. First responders to the explosion should establish and maintain physical control of the structure and surrounding areas. Unauthorized persons should be prevented from entering the scene or touching blast debris remote from the scene itself because the critical evidence from an explosion (whether accidental or criminal) may be very small and may be easily disturbed or moved by people passing through. Evidence is also easily picked up on shoes and tracked out. Properly securing the scene also tends to prevent additional injuries to unauthorized persons or to the curious who may attempt to enter an unsafe area.

18.13.1.1 Establishing the Scene. As a general rule, the outer perimeter of the incident scene should be established at 1^{1/2} times the distance of the farthest piece of debris found. Significant pieces of blast debris can be propelled great distances or into nearby buildings or vehicles, and these areas should be included in the scene perimeter. If additional pieces of debris are found, the scene perimeter should be widened.

18.13.1.2 Obtain Background Information. Before beginning any search, all relevant information should be obtained pertaining to the incident. This should include a description of the incident site and systems or operations involved and of conditions and events that led to the incident. The locations of any combustibles and oxidants that were present and what abnormal or hazardous conditions existed that might account for the incident need to be determined. Any pertinent information regarding suspected explosive materials and causes will of course be of interest and will aid in the search as well.

In developing the evidence, the investigator should examine witness accounts, maintenance records, operational logs, manuals, weather reports, previous incident reports, and other relevant records. Recent changes in equipment, procedures, and operating conditions can be especially significant.

Obtaining drawings of the building or process will greatly improve documentation of the scene, especially if notes can be made on them.

18.13.1.3 Establish a Scene Search Pattern. The investigator should establish a scene search pattern. With the assistance of investigation team members, the scene should be searched from the outer perimeter inward toward the area of greatest damage. The final determination of the location of the explosion's epicenter should be made only after all of the scene has been examined.

The search pattern itself may be spiral, circular, or grid shaped. Often the particular circumstances of the scene will dictate the nature of the pattern. In any case, the assigned areas of the search pattern should overlap so that no evidence will be lost at the edge of any search area. It is often useful to search areas more than once. When this is done, a different searcher should be used to help ensure that evidence is not overlooked.

The number of actual searchers will depend on the physical size and complexity of the scene. The investigator in charge should keep in mind, however, that too many searchers can often be as counterproductive as too few. Searchers should be briefed as to the proper procedures for identifying, logging, photographing, and marking and mapping the location of evidence. Consistent procedures are imperative whenever there are several searchers involved.

The location of evidence may be marked with chalk marks, spray paint, flags, stakes, or other marking means. After photographing, the evidence may be tagged, moved, and secured. (See Chapters 13 and 14.)

18.13.1.4 Safety at the Explosion Scene. All of the fire investigation safety recommendations listed in Chapter 10 also apply for the investigation of explosions. In addition, there are some special safety considerations at an explosion scene.

Structures that have suffered explosions are often more structurally damaged than merely burned buildings. The possibility of floor, wall, ceiling, roof, or entire building collapse is much greater and should always be considered.

In the case of fuel gas or dust explosions, secondary explosions are the rule rather than the exception. Early responders need to remain alert to that possibility. Leaking gas or pools of flammable liquids need to be made safe before the investigation is begun. Toxic materials in the air or on material surfaces need to be neutralized. The use of appropriate personal safety equipment is recommended.

Explosion scenes that involve bombings or explosives have added dangers. Investigators should be on the lookout for additional devices and undetonated explosives. The modus operandi (M.O.) of some bomber/arsonists includes using secondary explosive devices specifically targeted for the law enforcement or fire service personnel who will be responding to the bombing incident.

A thorough search of the scene should be conducted for any secondary devices prior to the initiation of the postblast investigation. If undetonated explosive devices or explosives are found, it is imperative that they not be moved or touched. The area should be evacuated and isolated, and explosives disposal authorities summoned.

Table 18.13.2 Typical Explosion Characteristics

Typical Characteristics	Lighter-than-Air Gases	Heavier-than-Air Gases	Liquid Vapors	Dusts	Explosives	Backdrafts	BLEVEs
Low-order damage	3	4	4	2	2	5	2
High-order damage	2	1	1	2	3	0	2
Secondary explosion	3	3	2	4	0	1	0
Gas/vapor/dust pocketing	3	2	2	2	0	0	0
Deflagration ^a	4	4	4	4	1	5	4 ^b
Detonation	1	1	1	1	4	0	1 ^b
Underground migration	2	2	2	0	0	0	0
BLEVEs	2	3	5	0	0	0	5
Postexplosion fires	3	3	4	3	1	5	3
Pre-explosion fires	2	2	2	3	2	5	4
Seated explosions	0 ^c	0 ^c	0 ^c	0	4 ^d	0	2
Minimum ignition energy (mJ) ^e	0.17–0.25	0.17–0.25	0.25	10–40	e		f

Note: 0 = never, 1 = seldom, 2 = sometimes, 3 = often, 4 = nearly always, 5 = always.

^aDeflagrations may transition into detonations under certain conditions.

^bThe strength of the confining vessel may allow the pressure wave at failure to be supersonic.

^cGases and vapors may produce seats if confined in small vessels, and if the materials on which they explode can be sufficiently compressed or shattered.

^dAll high explosives and some low explosives will produce seated explosions if the materials on which they explode can be sufficiently compressed or shattered.

^eIgnition energies vary widely. Most modern high explosives are designed to be insensitive to ignition. Energies for detonations are nine orders of magnitude larger than the minimum ignition energies.

^fBLEVEs are not combustion explosions and do not require ignitions.

18.13.2 Initial Scene Assessment. Once the explosion scene has been established, the investigator should make an initial assessment of the type of incident with which he or she is dealing. If at any time during the investigation the investigator determines that the explosion was fueled by explosives or involved an improvised explosive device (IED), he or she should discontinue the scene investigation, secure the scene, and contact the appropriate law enforcement agency.

Table 18.13.2 provides the investigator with a basic general guide for comparing the characteristics of explosion damage and fuels. It can aid in including or eliminating some kinds of explosions or fuels from the initial investigative assessment. For example, if the evidence indicates that high-order damage occurred, it can be assumed that the explosion was not the result of a backdraft.

18.13.2.1 Identify Explosion or Fire. The first task in the initial assessment is to determine whether the incident was a fire, explosion, or both, and which came first. Often the evidence of an explosion is not obvious, for example, where a weak explosion of fuel gases is involved.

The investigator should look for signs of an overpressure condition existing within the structure, including displacement or bulging of walls, floors, ceilings, doors and windows, roofs, other structural members, nails, screws, utility service lines, panels, and boxes. Localized fragmentation and pres-

sure damage should be noted as attributable to condensed phase explosive fuel reaction.

The investigator should look for and assess the nature and extent of heat damage to the structure and its components and decide whether it can be attributed to fire alone.

18.13.2.2 High- or Low-Order Damage. The investigator should attempt to determine whether the nature of damage indicates high-order or low-order damage. (See Section 18.3.) This will help classify the type, quantity, and mixture of the fuel involved.

18.13.2.3 Seated or Nonseated Explosion. The investigator should determine whether the explosion was seated or nonseated. This will help classify the type of possible fuel involved. (See Section 18.6.)

18.13.2.4 Identify Type of Explosion. The investigator should identify the type of explosion involved (e.g., mechanical, combustion, other chemical reaction, or BLEVE).

18.13.2.5 Identify Potential General Fuel Type. The investigator should identify which types of fuel were potentially available at the explosion scene by identifying the condition and location of utility services, especially fuel gases and sources of ignitable dusts or liquids.

The investigator should analyze the nature of damage in comparison to the typical damage patterns available from the following:

- (1) Lighter-than-air gases
- (2) Heavier-than-air gases
- (3) Liquid vapors
- (4) Dusts
- (5) Explosives
- (6) Backdrafts
- (7) BLEVEs

18.13.2.6 Establish the Origin. The investigator should attempt early on to establish the origin of the explosion. The origin will usually be identified as the area of most damage and will sometimes include a crater or other localized area of severe damage in the case of a seated explosion. In the case of a diffuse fuel–air explosion, the origin will be the confining volume or room of origin. (*See 4.19.2.*)

18.13.2.7 Establish the Fuel Source and Explosion Type. The investigator should identify which types of fuel were available at the explosion scene by identifying the condition and location of utility services, especially fuel gases, processing by-product dusts, or ignitable liquids.

The investigator should analyze the nature of damage in comparison to the typical damage patterns attributable to the following:

- (1) Lighter-than-air gases
- (2) Heavier-than-air gases
- (3) Liquid vapors
- (4) Dusts
- (5) Explosives
- (6) Backdrafts
- (7) BLEVEs

Thus, the type of explosion is established.

18.13.2.8 Establish Ignition Source. The investigator should attempt to identify the ignition source involved. At times, this can be very difficult. Examination should be made for potential sources — such as hot surfaces, electrical arcing, static electricity, open flames, sparks, chemicals, and so forth — where fuel–air mixtures are involved.

Where explosives are involved, the initiation source may be a blasting cap or other pyrotechnic device. Wires and device components will sometimes survive.

18.13.3 Detailed Scene Assessment. Armed with general information from the initial scene assessment, the investigator may now begin a more detailed study of the blast damage and debris. As in any fire incident investigation, the investigator should record his or her investigation and findings by accurate note taking, photography, diagramming, and mapping. It is important to use proper collection and preservation techniques. (*See Chapters 13 and 14.*)

18.13.3.1 Identify Damage Effects of Explosion. The investigator should make a detailed examination and analysis of the specific explosion or overpressure damage. Damaged articles should be identified as having been affected by one or more of the following typical explosion forces:

- (1) Blast pressure wave — positive phase
- (2) Blast pressure wave — negative phase
- (3) Shrapnel impact
- (4) Thermal energy
- (5) Seismic energy

The investigator should examine and classify the type of damage present — whether it was shattered, bent, broken, or flattened — and also look for changes in the pattern. At distances away from a detonation explosion epicenter, the pressure rise will be fairly moderate and the effects will resemble those of a deflagration explosion, while materials in the immediate vicinity of the detonation epicenter will exhibit splintering and shattering.

The investigator should make a detailed examination and analysis of the specific explosion or overpressure damage. Damaged articles should be identified as having been affected by one or more of the damaging effects of explosions: blast pressure fronts, shrapnel impact, thermal effects, and seismic effects.

The investigator should examine and classify the type of damage to each significant item present — whether it was shattered, bent, broken, or flattened — and also look for changes in the pattern. At distances away from a detonation explosion center, the pressure rise will be fairly moderate and the effects will resemble those of a deflagration explosion. Items in the immediate vicinity of the detonation center will exhibit splintering and shattering (i.e., brittle failure).

The scene should be examined carefully and fragments of any foreign material should be recovered, as well as debris from the seat itself. The fragments may require forensic laboratory analysis for their identification, but whether they are fragments of the original vessel or container or portions of an improvised explosive device, they may be critical to the investigation.

Tables 18.13.3.1(a) and 18.13.3.1(b) can be used as simplified guides to estimate the peak blast overpressure from the observed building damage and casualty data. These data are from peak overpressure applied to the structure's exterior. The effects of overpressure on the inside of the structure are considered to be similar, but the overpressure values may be different in some cases, depending on the construction involved.

It is noted that the estimation of structural damage from an explosion is a very complex topic. A thorough treatment involves maximum pressure and impulse of the explosion, as well as the natural period and strength characteristics of the confining structure. Generally, one can expect a peak overpressure of 1 psi to 2 psi (6.9 kPa to 13.8 kPa) to cause the failure of most light structural assemblies, such as nonreinforced wood siding, corrugated steel panels, or masonry block walls. In comparison, much higher overpressures can be tolerated when the structural design is reinforced, particularly with materials of good ductility (e.g., steel).

18.13.3.2 Identify Preblast and Postblast Fire Damage. Fire or heat damage should be identified as having been caused by a pre-existing fire or by the thermal effect of the explosion. Debris that has been propelled away from the point of origin should be examined to determine whether it has been burned. Debris of this nature that is burned may be an indicator that a fire preceded the explosion.

Probably the most common sign of an overpressure condition is window glass thrown some distance from the windows of the structure. The residue of smoke or soot on fragments of window glass or other structural debris reveals that the explosion followed a fire by some time, whereas perfectly clean pieces of glass or debris thrown large distances from the structure indicate an explosion preceding the fire.

The direction of flow of melted and resolidified debris may tell the investigator the position or attitude of the debris at the time of heat exposure.

Table 18.13.3.1(a) Human Injury Criteria (includes injury from flying glass and direct overpressure effects)

Overpressure (psi)	Injury	Comments	Source
0.6	Threshold for injury from flying glass*	Based on studies using sheep and dogs	a
1.0–2.0	Threshold for skin laceration from flying glass	Based on U.S. Army data	b
1.5	Threshold for multiple skin penetrations from flying glass (bare skin)*	Based on studies using sheep and dogs	a
2.0–3.0	Threshold for serious wounds from flying glass	Based on U.S. Army data	b
2.4	Threshold for eardrum rupture	Conflicting data on eardrum rupture	b
2.8	10% probability of eardrum rupture	Conflicting data on eardrum rupture	b
3.0	Overpressure will hurl a person to the ground	One source suggested an overpressure of 1.0 psi for this effect	c
3.4	1% eardrum rupture	Not a serious lesion	d
4.0–5.0	Serious wounds from flying glass near 50% probability	Based on U.S. Army data	b
5.8	Threshold for body-wall penetration from flying glass (bare skin)*	Based on studies using sheep and dogs	a
6.3	50% probability of eardrum rupture	Conflicting data on eardrum rupture	b
7.0–8.0	Serious wounds from flying glass near 100% probability	Based on U.S. Army data	b
10.0	Threshold lung hemorrhage	Not a serious lesion [applies to a blast of long duration (over 50 m/s)]; 20–30 psi required for 3 m/s duration waves	d
14.5	Fatality threshold for direct blast effects	Fatality primarily from lung hemorrhage	b
16.0	50% eardrum rupture	Some of the ear injuries would be severe	d
17.5	10% probability of fatality from direct blast effects	Conflicting data on mortality	b
20.5	50% probability of fatality from direct blast effects	Conflicting data on mortality	b
25.5	90% probability of fatality from direct blast effects	Conflicting data on mortality	b
27.0	1% mortality	A high incidence of severe lung injuries [applies to a blast of long duration (over 50 m/s)]; 60–70 psi required for 3 m/s duration waves	d
29.0	99% probability of fatality from direct blast effects	Conflicting data on mortality	b

Note: For SI units, 1 psi = 6.9 kPa.

*Interpretation of tables of data presented in reference.

^aFletcher, Richmond, and Yelverton, 1980.

^b*Loss Prevention in the Process Industries*.

^cBrasie and Simpson, 1968.

^dU.S. Department of Transportation, 1988.

Table 18.13.3.1(b) Property Damage Criteria

Overpressure (psi)	Damage	Source
0.03	Occasional breaking of large glass windows already under strain	a
0.04	Loud noise (143 dB). Sonic boom glass failure	a
0.10	Breakage of small windows, under strain	a
0.15	Typical pressure for glass failure	a
0.30	“Safe distance” (probability 0.95 no serious damage beyond this value) Missile limit Some damage to house ceilings 10% window glass broken	a
0.4	Minor structural damage	a, c
0.5–1.0	Shattering of glass windows, occasional damage to window frames. One source reported glass failure at 0.147 psi (1 kPa)	a, c, d, e
0.7	Minor damage to house structures	a
1.0	Partial demolition of houses, made uninhabitable	a
1.0–2.0	Shattering of corrugated asbestos siding Failure of corrugated aluminum–steel paneling Failure of wood siding panels (standard housing construction)	a, b, d, e
1.3	Steel frame of clad building slightly distorted	a
2.0	Partial collapse of walls and roofs of houses	a
2.0–3.0	Shattering of nonreinforced concrete or cinder block wall panels [1.5 psi (10.3 kPa) according to another source]	a, b, c, d
2.3	Lower limit of serious structural damage	a
2.5	50% destruction of brickwork of house	a
3.0	Steel frame building distorted and pulled away from foundations	a
3.0–4.10	Collapse of self-framing steel panel buildings Rupture of oil storage tanks Snapping failure — wooden utility tanks	a, b, c
4.0	Cladding of light industrial buildings ruptured	a
4.8	Failure of reinforced concrete structures	e
5.0	Snapping failure — wooden utility poles	a, b
5.0–7.0	Nearly complete destruction of houses	a
7.0	Loaded train wagons overturned	a
7.0–8.0	Shearing/flexure failure of brick wall panels [8 in. to 12 in. (20.3 cm to 30.5 cm) thick, not reinforced] Sides of steel frame buildings blown in	a, b, c, d d

Table 18.13.3.1(b) Property Damage Criteria (Continued)

Overpressure (psi)	Damage	Source
	Overturning of loaded rail cars	b, c
9.0	Loaded train boxcars completely demolished	a
10.0	Probable total destruction of buildings	a
30.0	Steel towers blown down	b, c
88.0	Crater damage	e

^a*Loss Prevention in the Process Industries.*

^bBrasie and Simpson, 1968.

^cU.S. Department of Transportation, 1988.

^dU.S. Air Force, 1983.

^eMcRae, 1984.

18.13.3.3 Locate and Identify Articles of Evidence. Investigators should locate, identify, note, log, photograph, and map any of the many and varied articles of physical evidence. Because of the propelling nature of explosions, the investigator should keep in mind that significant pieces of evidence may be found in a wide variety of locations, such as outside the exploded structure, embedded in the walls or other structural members of the exploded structure, on or in nearby vegetation, inside adjacent structures or vehicles, or embedded in these adjacent structures. In the case of bombing incidents or incidents involving the explosion of tanks, appliances, or equipment, significant pieces of evidence debris may have pierced the bodies of victims or be contained in their clothing.

The clothing of anyone injured in an explosion should be obtained for examination and possible analysis. The investigator should ensure that photographs are taken of the injuries and that any material removed from the victims during medical treatment or surgery is preserved. This is true whether the person survives or not.

Investigators should note the condition and position of any damaged and displaced structural components, such as walls, ceilings, floors, roofs, foundations, support columns, doors, windows, sidewalks, driveways, and patios.

Investigators should note the condition and position of any damaged and displaced building contents, such as furnishings, appliances, heating or cooking equipment, manufacturing equipment, victims' clothing, and personal effects.

Investigators should note the condition and position of any damaged and displaced utility equipment, such as fuel gas meters and regulators, fuel gas piping and tanks, electrical boxes/meters, electrical conduits and conductors, heating oil tanks, parts of explosive devices, or fuel vessels.

18.13.3.4 Identify Force Vectors. Investigators should identify, diagram, photograph, and note those pieces of debris that indicate the direction and relative force of the explosion. Keep in mind that the force necessary to shatter a wall is more than that necessary to merely dislodge or displace it. The force necessary to shatter a window is less than that to displace a wall, but more than that necessary to blow out a window intact. The greater the force, the farther is the distance that similar pieces of debris will be thrown from the epicenter.

The investigator should log, diagram, and photograph varying missile distances and directions of travel for similar debris, such as window glass. Larger, more massive missiles

should be measured and weighed for comparison of the forces necessary to propel them.

The distance as well as the direction of significant pieces of evidence from the apparent epicenter of the explosion may be critical. The location of all significant pieces should be completely documented on the explosion scene diagram, along with notes as to both distance and direction. This procedure allows the investigator to reconstruct the trajectories of various components.

18.14 Analyze Origin (Epicenter). After identifying the force vectors, the investigator should trace backward from the least to the most damaged areas, following the general path of the explosion force vectors. This is known as an *explosion dynamics analysis*. It can be accomplished most efficiently by plotting on a diagram of the exploded structure the various directions of debris movement and, if possible, an estimate of the relative force necessary for the damage or movement of each significant piece of debris. (See *Figure 18.14*.) A dimensional diagram is desirable in cases where an engineering analysis of the damage effects is anticipated.

The analysis of the explosion dynamics is based on the debris movement away from the epicenter of the explosion in a roughly spherical pattern and on the decreasing force of the explosion as the distance from the epicenter increases.

Often, more than one explosion dynamics diagram is necessary. The first might show a relatively large area that may indicate a specific area or room for further study as the origin. A second, smaller-scale diagram might then be constructed to analyze the explosion dynamics of the area of origin itself. This is especially useful when dealing with a seated explosion.

Often, especially when dealing with nonseated explosions, such as fugitive fuel gas explosions, the investigator may be unable to pinpoint the epicenter any more precisely than to a specific room or area.

The explosion dynamics analysis is often complicated by evidence of a series of explosions, each with its own epicenter. This situation calls for a detailed comparison of the force vectors. Movement of more solid debris, such as walls, floors, and roofs, is generally less in subsequent explosions than in the first. The first forceful explosion tends to vent the structure, allowing more of the positive pressure phase of subsequent explosions to be released.

This finding is true, however, only when the secondary explosions are of the same or lesser force than the first. Dust explosions are a notable exception to this phenomenon, with subsequent explosions almost always being more powerful than the first.

FIGURE 18.14 Explosion dynamics diagram. Arrows indicate direction of displacement of walls, doors, and windows.

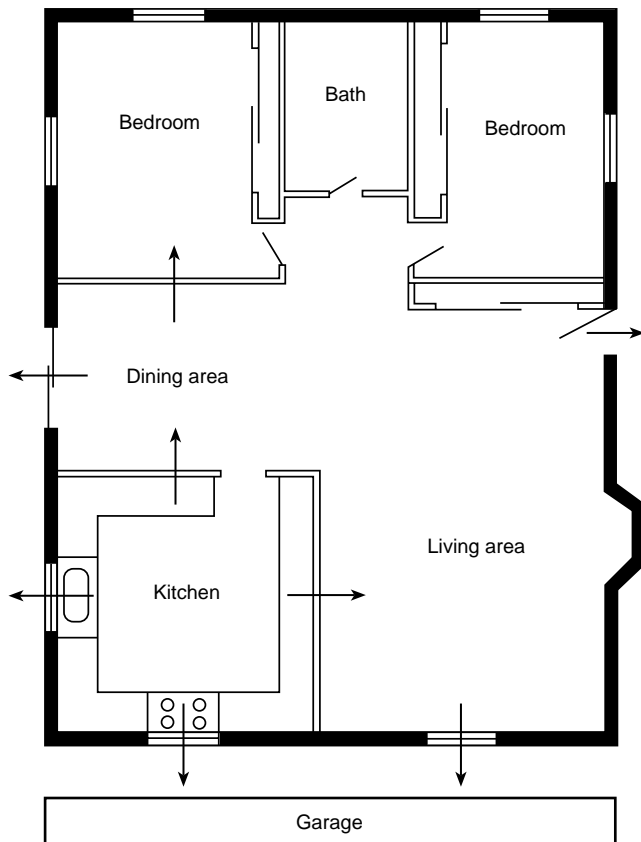

18.15 Analyze Fuel Source. Once the origin or epicenter of the explosion has been identified, the investigator should determine the fuel. This is done by a comparison of the nature and type of damage to the known available fuels at the scene.

All available fuel sources should be considered and eliminated until one fuel can be identified as meeting all of the physical damage criteria. For example, if the epicenter of the explosion is identified as a 6 ft (1.8 m) crater of pulverized concrete in the center of the floor, fugitive natural gas can be eliminated as the fuel, and only fuels that can create seated explosions should be considered.

Chemical analysis of debris, soot, soil, or air samples can be helpful in identifying the fuel. With explosives or liquid fuels, gas chromatography, mass spectrography, or other chemical tests of properly collected samples may be able to identify their presence.

Air samples taken in the vicinity of the area of origin can be used in identifying gases or the vapors of liquid fuels. For example, commercial “natural gas” is a mixture of methane, ethane, propane, nitrogen, and butane. The presence of ethane in an air sample may show that commercial “natural gas” was there rather than naturally occurring “swamp, marsh, or sewer” gas, which is all methane.

Once a fuel is identified, the investigator should determine its source. For example, if the fuel is identified as a lighter-than-air gas and the structure is serviced by natural gas, the investigator should locate the source of gas that will most likely be at or below the epicenter, possibly from a leaking service line or malfunctioning gas appliance.

All gas piping, including from the street mains or LP-Gas storage tanks, up to and through the service regulator and meter, to and including all appliances, should be examined and leak tested if possible. (See *NFPA 54, National Fuel Gas Code, Appendix D, or the National Fuel Gas Code Handbook.*) Leak testing inside a building that has had a fire or gas explosion should be performed using air or an inert gas.

Odorant verification should be part of any explosion investigation involving, or potentially involving, flammable gas, especially if there are indications that there were no indications of a leaking gas detected by people present. Its presence should be verified. Stain tubes can be used in the field, and gas chromatography can be used as a lab test for accurate results.

18.16 Analyze Ignition Source. When the origin and fuel are identified, the means of ignition should be analyzed. This is often the most difficult part of the overall explosion investigation because, especially with fugitive fuel gases, multiple ignition sources are present. In the event of multiple possible ignition sources, the investigator should take into consideration all the available information, including witness statements. A careful evaluation of every possible ignition source should be made. Factors to consider include the following:

- (1) Minimum ignition energy of the fuel
- (2) Ignition energy of the potential ignition source
- (3) Ignition temperature of the fuel
- (4) Temperature of the ignition source
- (5) Location of the ignition source in relation to the fuel
- (6) Simultaneous presence of the fuel and ignition source at the time of ignition
- (7) Witness accounts of conditions and actions immediately prior to and at the time of the explosion

18.17 Analyze to Establish Cause. Having identified the origin, fuel, and ignition source, the investigator should now analyze and determine what brought together the fuel and ignition at the origin. The circumstances that brought these elements together at that time and place are the cause. (See *Chapter 16.*)

Part of this analysis may include considerations of how the explosion could have been prevented, such as failure to conform to existing codes or standards. It should be noted that, due to the destructive effects of fire and explosions, the cause cannot always be determined.

Many techniques are suggested in 18.17.1 through 18.17.5 to aid in establishing causation. The choice of the technique(s) used will depend on the unique circumstances of the incident.

18.17.1 Time Line Analysis. Based on the background information gathered (e.g., statements and logs), a sequence of events should be tabulated for the time both prior to the explosion and during the explosion. Consistencies and inconsistencies with causation theories can then be surmised and a “best fit” theory established. (See *Section 17.2 for more information on time line analysis.*)

18.17.2 Damage Pattern Analysis. Various types of damage patterns can be documented for further analysis, principally debris and structural damage.

18.17.2.1 Debris Analysis. Investigators should identify, diagram, photograph, and note those pieces of debris that indicate the direction and relative force of the explosion. In general, the greater the explosive energy, the farther similar pieces of debris will be thrown from the center of the explosion. However, different drag/lift (i.e., aerodynamic) characteristics of various fragment shapes will tend to favor some going farther.

The distance as well as the direction of significant pieces of evidence from the apparent center of the explosion may be critical. The location of all significant pieces should be completely documented on the explosion scene diagram, along with notes as to both distance and direction. This procedure allows the investigator to reconstruct the trajectories of various components. In some cases, it is desirable to weigh and make geometric measurements of significant missiles, especially large ones. This can then be used in a more complete engineering analysis of trajectories.

18.17.2.2 Relative Structural Damage Analysis. Investigators should diagram the relative damage to the areas surrounding the explosion site. Such a diagram can be called an *iso-damage contour map*. Criteria for contours may be simple overpressure levels in some cases, or the relative damage ratings for structures. Several techniques are employed for this purpose. Such an analysis will give additional clues to explosion propagation and can be used for further input to a more complete engineering analysis.

18.17.3* Correlation of Blast Yield with Damage Incurred. There are several methods that analysts use to correlate the degree of damage and projectile distance with the type and amount of fuel involved. Due to the great differences in chemical dynamics between solid explosives and gas/vapor deflagrations, it is not possible to directly correlate the amount of fuel involved in one to the weight of explosive used in the other. Weight equivalencies for common condensed-phase explosives can be found in the literature. (See *Appendix A*.)

18.17.4 Analysis of Damaged Items and Structures. Frequently, the determination of the cause in explosion incidents requires a multidisciplinary approach to relate damage to the fuels involved. The use of special experts may be necessary. (See *Section 12.5*.)

18.17.5 Correlation of Thermal Effects. A collection of articles exhibiting heat damage from an explosive event may be evidence of a fireball or fire during the sequence of events. These articles may be further proof that the explosion involved a BLEVE, a fuel jet fire, or other phenomenon, depending on the character of those articles. Specialized analysis of thermal damage effects can be conducted by a person trained in this area. From this material, an isothermal diagram (i.e., heat damage map) can be developed.

Chapter 19 Incendiary Fires

19.1 Introduction. An incendiary fire is a fire that has been deliberately ignited under circumstances in which the person knows the fire should not be ignited. This section provides guidance to assist the investigator in identifying incendiary fires and documenting evidence regarding their origin and cause. In the event the investigator concludes that a fire was incendiary, other evidentiary factors are addressed regarding suspect development and identification.

The existence of a single indicator or a combination of indicators is not necessarily conclusive proof that a fire is of incendiary cause. However, the presence of indicators may suggest that the fire deserves further investigation.

19.2 Incendiary Fire Indicators. There are a number of conditions related to fire origin and spread that may provide physical evidence of an incendiary fire cause.

19.2.1 Multiple Fires. Multiple fires are two or more separate, nonrelated, simultaneously burning fires. The investigator should search to uncover any additional fire sets or points

of origin that may exist. In order to conclude that there are multiple fires, the investigator should determine that any "separate" fire was not the natural outgrowth of the initial fire.

Fires in different rooms, fires on different stories with no connecting fire, or separate fires inside and outside a building are examples of multiple fires. A search of the fire building and its surrounding areas should be conducted to determine whether there are multiple fires.

Apparent multiple fires can result through spread by the following means:

- (1) Conduction, convection, or radiation
- (2) Flying brands
- (3) Direct flame impingement
- (4) Falling flaming materials (i.e., drop down) such as curtains
- (5) Fire spread through shafts, such as pipe chases or air-conditioning ducts
- (6) Fire spread within wall or floor cavities within "balloon construction"
- (7) Overloaded electrical wiring
- (8) Utility system failures

Apparent multiple points of origin can also result from continued burning at remote parts of a building during fire suppression and overhaul, particularly when building collapse or partial building collapse is involved.

The earlier a fire is extinguished, the easier it is to identify multiple points of origin. Once full room involvement or room-to-room extension has occurred, identifying multiple fires becomes more difficult and a complete burnout or "black hole" may make identification impossible.

If there has been a previous fire in the building, care should be taken not to confuse earlier damage with a multiple fire situation.

Fire scene reconstruction (*see Section 15.7*), an important aspect of the fire scene examination, is especially important when multiple fires are suspected.

A careful examination of the fire scene may reveal additional fire sets (which are intended to ignite additional fires), particularly in the same type of area. For example, if the investigator observes or discovers an area of origin in a closet, an examination of other closets for additional fires or fire sets is prudent. The investigator may be required to obtain legal authority to conduct a search in areas not affected or involved in the discovered fire. (*See 9.2.2 and 9.2.3*.)

Confirmation of multiple fires is a compelling indication that the fire was incendiary.

19.2.2 Trailers. After incendiary fires, when fuels have been intentionally distributed or "trailed" from one area to another, elongated patterns may be visible. Such fire patterns, known as *trailers*, can be found along floors to connect separate fire sets, or up stairways to move fires from one story or level within a structure to another. Fuels used for trailers may be ignitable liquids, solids, or combinations of these. (*See Figure 4.18.1*.)

Materials such as clothing, paper, straw, and ignitable liquids are often used. Remnants of solid materials frequently are left behind and should be collected and documented.

Ignitable liquids may leave linear patterns, particularly when the fires are extinguished early. Radiant energy from the extension of flame or hot gases through corridors or up stairways can also produce linear patterns. As with suspected solid accelerants, samples of possible liquid accelerants should be collected and analyzed. (*See Section 14.5*.)

Often, when the floor area is cleared of debris to examine damage, long, wide, straight patterns will be found showing

areas of extensive heat damage, bound on each side by undamaged or less damaged areas. These patterns have often been interpreted to be trailers. While this conclusion is possible, the presence of furniture, stock, counters, or storage may result in these linear patterns. These patterns may also result from fire impact on worn areas of floors and the floor coverings. Irregularly shaped objects on the floor, such as clothing or bedding, may provide protection to the floor, resulting in patterns that may be inaccurately interpreted.

For example, gasoline itself poured out to assist the fire is an accelerant. It is the deliberate use of the gasoline to spread the fire from one location to another that causes the stream of gasoline to be a trailer. Trailing gasoline from one room to another and up the staircase constitutes laying a trailer. Dousing a building with gasoline from cellar to rooftop or over a widespread area does not constitute laying a trailer; instead, it is considered using an accelerant. So it can be seen that the fuel does not constitute a trailer, but rather the manner in which the fuel or accelerant is used. This distinction is similar to the "use" requirement in the definition of an accelerant. The burning action has no effect on whether there is a trailer. Gasoline, rags, or newspapers can all be used as trailers, but they burn differently. The pattern that is left by a trailer is evidence of the trailer; the pattern is not the trailer. If an arsonist lays a trailer but is arrested prior to ignition, there is still a trailer.

19.2.3 Lack of Expected Fuel Load or Ignition Sources. When the fire damage at the origin is inconsistent with the expected low fire loads, limited rates of heat release, or limited potential-accidental ignition sources, the fire may be incendiary. An example of all three is an isolated burn at floor level in a large, empty room. Examples of limited fire load areas include corridors and stairways. Stairways, while usually having limited fire loads, may promote rapid fire spread by allowing flames or hot gases to travel vertically to other areas. This action may cause severe damage on exposed stairway surfaces. Additional examples of areas with limited potential-accidental ignition sources include closets, crawl spaces, and attics.

19.2.4* Exotic Accelerants. Mixtures of fuels and Class 3 or Class 4 oxidizers (*see NFPA 430, Code for the Storage of Liquid and Solid Oxidizers*) may produce an exceedingly hot fire and may be used to start or accelerate a fire. Thermite mixtures also produce exceedingly hot fires. Such accelerants generally leave residues that may be visually or chemically identifiable.

Exotic accelerants have been hypothesized as having been used to start or accelerate some rapidly growing fires and were referred to in these particular instances as high temperature accelerants (HTA). Indicators of exotic accelerants include an exceedingly rapid rate of fire growth, brilliant flares (particularly at the start of the fire), and melted steel or concrete. A study of 25 fires suspected of being associated with HTAs during the 1981-1991 period revealed that there was no conclusive scientific proof of the use of such HTA.

In any fire where the rate of fire growth is considered exceedingly rapid, other reasons for this should be considered in addition to the use of an accelerant, exotic or otherwise. These reasons include ventilation, fire suppression tactics, and the type and configuration of the fuels.

19.2.5 Unusual Fuel Load or Configuration. If the investigation reveals the presence of an unusually large fuel load in the area of origin, or a fuel load in the area of origin that either would normally not be expected in that area or would not be expected to be in the configuration in which it was found, the fire may be incendiary. An example of an unusual configura-

tion is where furniture, stock, or contents are deliberately stacked or piled in a configuration to encourage rapid or complete fire development. An example of an unusually large fuel load is where accumulations of trash, debris, or cardboard cartons are deliberately introduced into a room or space in order to encourage greater fire involvement.

19.2.6 Burn Injuries. The manner and extent of burn injuries may provide clues to the origin, cause, or spread of the fire. Burn injuries may be sustained while setting an incendiary fire. The investigator should ascertain whether the fire victim's burns and the nature and extent of the injuries are consistent with the investigative hypothesis regarding fire cause and spread. The investigator should check the local hospitals for the identification of any persons admitted or treated for burn injuries.

19.2.7 Incendiary Devices. *Incendiary device* is a term used to describe a wide range of mechanisms used to initiate an incendiary fire. In some cases, the firesetter may have used more than one incendiary device. Frequently, remains of the fuel used will be found with the ignition device. If an incendiary fire is suspected, the investigator should search for other fire sets that may have burned out or failed to operate.

WARNING

When an incendiary device is discovered that has not activated, *do not move it!* Such devices must be handled by specially trained explosive ordnance disposal personnel. Touching or moving such devices is extremely dangerous and can result in an ignition or explosion.

19.2.7.1 Examples of Incendiary Devices. Examples of some incendiary devices, and the evidence that may establish their presence or use, are as follows:

- (1) Books of paper matches and cigarettes from which the striker from the matchbook, cigarette filters, remaining cigarette ash, and the combustible materials ignited by the matches or cigarettes may be found in the area of origin
- (2) Candles from which their wax and the remains of any combustible material ignited by the candles may be found in the area of origin
- (3) Wiring systems or electric heating appliances to initiate a fire (which may be evidenced by indications of tampering or modification of the wiring system, by the movement or arrangement of heat-producing appliances to locations near combustible materials, or by evidence of combustible materials being placed on or near heat-producing appliances)
- (4) Fire bombs, commonly called Molotov cocktails (which leave evidence in the form of the ignitable liquid, chemicals, or compounds used within them, the broken containers, and wicks)
- (5) Paraffin wax-sawdust incendiary device (which can be evidenced by remains of wax impregnated with sawdust, for example, artificial fire logs)

19.2.7.2 Delay Devices. Timers or delay devices can be employed to allow the firesetter an opportunity to leave the scene and to possibly establish an alibi prior to the ignition. Common delay devices include candles, cigarettes, and mechanical or electrical timers.

19.2.7.3 Presence of Ignitable Liquids in Area of Origin. The use or presence of ignitable liquids is generally referred to as a *liquid accelerant* when used in conjunction with an incendiary fire.

The presence of ignitable liquids may indicate that a fire was incendiary, especially when the ignitable liquids are found

in areas in which they are not normally expected. Containers of ignitable liquids in an automobile garage may not be unusual, but a container of ignitable liquids found in a bedroom may be unusual. In either case, the presence of ignitable liquids near the area of origin should be fully investigated.

“Irregular patterns” (*see 4.17.7.2*) may indicate the presence of an ignitable liquid. If the investigator observes patterns associated with a liquid accelerant, he or she may also observe the remains of a container used to hold the liquid. The investigator should ensure that samples are taken from any area where ignitable liquids are suspected to be present.

19.2.8 Assessment of Fire Growth and Fire Damage. Investigators may form an opinion that the speed of fire growth or the extent of damage was greater than would be expected for the “normal” fuels believed to be present and for the building configuration. However these opinions are subjective. Fire growth and damage are related to a large number of variables, and the assumptions made by the investigator are based on that investigator’s individual training and experience. If subjective language is used, the investigator should be able to explain specifically why the fire was “excessive,” “unnatural,” or “abnormal.”

What an investigator may consider as “excessive,” “unnatural,” or “abnormal” can actually occur in an accidental fire, depending on the geometry of the space, the fuel characteristics, and the ventilation of the compartment (*see 3.5.4*). Some plastic fuels that are difficult to burn in the open may burn vigorously when subjected to thermal radiation from other burning materials in the area. This might occur in the conditions during or after flashover.

The investigator is strongly cautioned against using subjective opinions to support an incendiary cause determination in the absence of physical evidence.

Mathematical models of fire growth exist that can provide assistance, if used properly, in assessing the potential accuracy of these subjective observations.

19.3 Potential Indicators Not Directly Related to Combustion. These indicators are generally conditions or circumstances that, in and of themselves, are not directly related to the fire or explosion cause, but that may be used by the investigator to develop ignition hypotheses, to select witnesses for interviewing, to develop suspects, and to develop avenues for further investigation. The indicators in this section are those that tend to show that somebody had prior knowledge of the fire.

19.3.1 Remote Locations with View Blocked or Obscured. A fire in a secluded location or where the view is hidden from observation may indicate a firesetter who did not want to be seen or caught. Fires at such locations would also allow the fire to develop before it was discovered. Examples include situations where windows are painted over or paper covers the windows for no apparent reason other than to conceal the fire.

19.3.2 Fires Near Service Equipment and Appliances. A fire near gas or electrical equipment, appliances, or fireplaces may be intended to make the fire appear to be from an accidental cause. The investigator should examine the fuel supply or service connections to determine whether they were loose or disconnected and then should determine whether tampering or sabotage of the equipment or appliances has occurred. If the investigator does not have sufficient knowledge regarding the equipment or appliance, it should be examined by qualified personnel.

19.3.3 Removal or Replacement of Contents Prior to the Fire. Through the course of the investigation, the investigator may believe that prior to the fire, the contents of a building have been removed or replaced with less or more valued items.

19.3.3.1 Replacement. When the investigator believes the contents to have been replaced, as complete an inventory as possible of the contents should be made prior to release of the building. The inventory of the pre-fire structure should be obtained and corroborated through witness statements, invoice and inventory receipt, and so forth. The insurance proof of loss and underwriting file will provide a list of what was claimed to have been present.

The items and contents that may be replaced depends on the occupancy of the building or space. Consider the following examples:

- (1) Residential occupancy — furniture, clothing
- (2) Industrial/commercial occupancy — machinery, equipment, stock, merchandise
- (3) Vehicles — tires, batteries

If contents that are abnormal to the occupancy are found, this can be another indicator.

19.3.3.2 Removal. Fire scenes or fire buildings that are devoid of the “normal” contents reasonably expected (or identified through witness statements, etc.) to be in the structure prior to the fire should be investigated and explained. The items removed are generally valuable items (such as television sets, VCRs, stereo systems, computers, camera equipment, stock, or equipment) or items that are difficult to replace (including files, business records, etc.).

Other items that may be removed prior to a fire may be those incriminating to a firesetter.

19.3.3.3 Absence of Personal Items Prior to the Fire. The absence of items that are personal, irreplaceable, or difficult items to replace should be investigated. Examples include jewelry, photographs, awards, certificates, trophies, art, pets, sports and hobby equipment, and so forth. Also, the removal of the important documents (e.g., fire insurance policy, business records, tax records) prior to the fire should also be investigated and explained.

19.3.4 Entry Blocked or Obstructed. The entrance to a structure or to the property may be blocked or obstructed to hamper fire fighters from extinguishing the fire. Obstructions to the property may include fallen trees, street barricades, or construction features that deny fire vehicle access, such as masonry columns, fences, and gates.

Obstructions to the structure may include what appear to be “security” measures — such as boarded up windows and doors, “security grilles,” chains and locks, and so forth — to the building.

19.3.5 Sabotage to the Structure or Fire Protection Systems. Sabotage refers to intentional damage or destruction to the physical structure of the building, or intentional damage to a fire protection system or system components.

A firesetter is often intent on developing conditions that will lead to the rapid and complete destruction of the building or its contents. In order to fulfill this goal, the firesetter may sabotage the structure (fire-resistive assembly) or the fire protection systems.

Investigators should determine whether the failure of structural components or fire protection systems was the result of deliberate sabotage or other factors, such as improper

construction, lack of maintenance, systems shutdown for maintenance, improper design, or equipment or structural assembly failure.

19.3.5.1 Damage to Fire-Resistive Assemblies. Fire-resistive design, accomplished through the construction of various fire resistance-rated assemblies (e.g., walls, ceilings, and floors) and the proper protection of openings (e.g., fire doors, windows and shutters, and fire dampers) is intended to separate portions of a structure into “compartments” or “fire areas” that confine a fire within the “compartment” in which the fire originated, preventing smoke and fire movement to other portions of the building.

Penetrations in fire-resistant assemblies may be an indication that the firesetter attempted to spread the fire from one area to another. The investigator should try to determine whether the penetrations occurred with the intent of spreading the fire. Penetrations of fire resistance-rated construction may be the result of poor initial construction, renovations, service wiring, or cables, or may be the result of fire-fighting activities, such as ventilation or overhaul.

Open doors are the most common method of fire travel through a structure. Sabotage to fire or smoke doors (e.g., wedging doors open) or fire shutters can increase fire and smoke spread throughout the structure. Sabotage to stairway doors can further increase rapid smoke and fire spread. However, frequently these doors are held or propped open by building occupants to improve ventilation or access during regular building operations. The investigator should determine whether the doors and other opening protection were intentionally opened by the firesetter or were open as a normal operational use of the building.

19.3.5.2 Damage to Fire Protection Systems. Fire protection systems include heat, smoke, or flame detection; alarm and signaling systems; sprinkler and standpipe systems; special extinguishing systems, such as those using carbon dioxide, foam, or halon; and private water mains and fire hydrants.

Sabotage to fire protection systems or components can delay notification to occupants and the fire department and can prevent the control or extinguishment of the fire. Such sabotage is intended to allow the fire to develop fully and to create greater destruction.

Sabotage can include removing or covering smoke detectors; obstructing sprinkler heads; shutting off control valves; damaging threads on standpipes, hose connections, or fire hydrants; and obstructing or placing debris in fire department Siamese connections or fire hydrants.

Another type of sabotage, although more subtle, is igniting multiple fires (*see 19.2.1*). In addition to increased destruction from additional fires, multiple fires can have the effect of overtaxing the fire suppression system beyond its design capabilities. Assistance may be needed to determine the design limitations on the fire protection system. (*See Section 12.5.*)

19.3.6 Open Windows and Exterior Doors. Open windows and exterior doors can speed the growth and spread of a fire. When these conditions exist during cold weather or in violation of normal building security, it may be an indicator that someone attempted to provide extra ventilation for the fire. Windows may have been broken out for the same purpose.

19.4 Other Evidentiary Factors. Once the investigator has completed the fire scene examination and has concluded that the fire was incendiary, there are other evidentiary factors that should be recorded and examined, which may be critical regarding future suspect development and identification.

These evidentiary factors regarding the identification of a suspected firesetter, or the “motive” or opportunity for the fire, cannot be substituted for a properly conducted investigation and determination of the fire’s origin and cause.

In the absence of physical evidence of an incendiary fire, the investigator is strongly cautioned against using the discovery or presence of these other evidentiary factors in developing an hypothesis, forming opinions, or drawing conclusions concerning the cause of the fire.

19.4.1 Analysis of Confirmed Incendiary Fires. It is through the analysis of confirmed incendiary fires that trends or patterns in repetitive firesetting behaviors may be detected. The key to this analysis is whether the firesetting is repetitive or not. This analysis may assist the investigator in the development and identification of possible suspects. Repetitive firesetting, sometimes called *serial fire setting* or *serial arson*, refers to a series of two or more (incendiary) fires, where the ignition is attributed to the individual or a group acting together. There are three principal trends that may be identified through analysis; these are geographic area or “clusters,” temporal frequency, and materials and methods.

19.4.1.1* Geographic Area, Clusters. Repetitive firesetting activities tend to group within the same geographic location (i.e., same neighborhood), or cluster. Locating incendiary fires by utilizing computer-assisted pattern recognition systems such as the Arson Information Management System (AIMS) or by looking at a map of the local area can assist the investigator in identifying clusters.

19.4.1.2 Temporal Frequency. Incendiary fires set by the same individual often occur during the same time period of the day or on the same day of the week. This may have several reasons, including the level of activity in the area, the firesetter’s assessment of his or her chances of success, or the firesetter’s routine. For example, the firesetter may pass the location (e.g., to or from work or to or from a bar) during a certain period of the day or on a certain day of the week.

19.4.1.3 Materials and Method. The method and material used in the ignition of incendiary fires vary according to the firesetter. Generally, however, once a firesetter begins repetitive firesetting behavior, the materials and method tend to remain similar, as do the locations of the incendiary fires.

19.4.2 Evidence of Other Crimes, Crime Concealment. An incendiary fire may be an attempt to conceal other crimes, such as homicides and burglaries. In other cases, a staged burglary may occur to disguise an incendiary fire. The issue of which occurred first, the other crime or the fire, is more related to the motive for the fire and has little to do with the cause of the fire.

Though possible motives are not determinative in investigating a fire’s cause (i.e., if the motive was to burglarize the structure and to conceal the burglary with a fire, or if the motive was to set a fire but make it appear as a burglary), motives may lead the investigator to approach the investigation (and the search for evidence) and possible suspects differently.

19.4.3 Indications of Financial Stress. The investigation may reveal indicators of financial stress. These indicators may include the following: liens, attachments, unpaid taxes, mortgage payments in arrears, real estate for sale (inability to sell, property is nonmarketable, etc.), poor business location, or new competition.

Financial stress may also be indicated by factors associated with the use or type of occupancy of the building. For business occupancies, indicators may include periods of economic decline, particularly within that industry; changes within an industry, in either product or equipment; obsolescence of equipment; and new competition within the industry. Other indicators can include factors such as the need to relocate or new competition in the same geographic region or area.

Examples of financial stress for residential properties can include landlords who cannot collect rent or who cannot rent out vacant units, rent control, the owner's need to relocate, and mass loss of jobs within the region resulting from industrial cutbacks or closings.

19.4.4 Existing or History of Code Violations. Closely related to, and possibly another indication of financial stress, is the existence of or a history of building, fire safety, housing, or maintenance code violations. This may indicate either the financial inability to maintain the building or the intentional choice to let the building deteriorate (refusal to reinvest in the structure).

Where the deterioration of a building is intentional, other indicators related to financial stress, such as overinsurance or the inability to sell the property, may be discovered during the investigation.

19.4.5 Owner with Fires at Other Properties. If a structure is owned by persons who have had incendiary fires at other properties, especially if they have collected insurance as a result of those fires, there is a possibility they will experience another incendiary fire.

19.4.6 Overinsurance. Another indicator closely related to financial stress is overinsurance. Overinsurance is a condition whereby the insurance coverage is greater than the value of the property in a valued policy state or whereby there are multiple insurance policies on the property.

19.4.7 Timed Opportunity. Timed opportunity refers to the indicators that a firesetter has timed the fire to coincide with conditions or circumstances that assist the chances of successful destruction of the target (property) or to utilize those conditions or circumstances to increase the chances of not being apprehended.

19.4.7.1 Fires During Severe Natural Conditions. Fires during periods of extreme natural conditions such as floods, snowstorms, hurricanes, or earthquakes may delay fire department response or hinder fire-fighting capabilities.

Other natural conditions to note are electrical storms, periods of high winds, low humidity, and freezing or extremely high temperatures.

19.4.7.2 Fires During Civil Unrest. This is a type of opportunistic fire. Other indicators such as financial stress often accompany this indicator.

Also, incendiary fires during civil unrest usually do not involve elaborate ignition devices or materials, although "fire bombs" or liquid accelerants are sometimes used. More often, available materials are utilized as an initial fuel.

A similar pattern may develop when *repetitive fires* or a series of incendiary fires occur in the same geographic area (*see 19.4.1.1*). The owners or occupants may attempt to set a fire and have the cause attributed to another firesetter. In these instances, the investigator may discover a difference in the method (such as time of day, days of the week, location of the fire), the materials

(such as different fuels) used, or ignition source that does not fit the established firesetting pattern. (*See 19.4.1.*)

19.4.7.3 Fire Department Unavailable. Fires may be set at times when the fire department is unavailable. Examples include deliberately calling in a false alarm to get the fire department away from the area or starting the fire while there is a working fire in progress or when the fire department is involved in a parade or other community function.

19.4.8* Motives for Firesetting Behavior. Motive indicators should not be included or substituted as analytical elements of the fire scene for the purpose of determining or classifying the fire cause. The proper use of motive indicators in the fire investigation process is in identifying potential suspects only after the fire origin and cause has been determined and the fire has been classified as incendiary.

Motive is defined as an inner drive or impulse that is the cause, reason, or incentive that induces or prompts a specific behavior. The identification of an offender's motive is a key element in crime analysis. Crime analysis is a method of identifying personality traits and characteristics exhibited by an unknown offender. It is the identification and analysis of the personality traits that eventually lead to the classification of a motive. Once a possible motive is identified, the investigator can begin to evaluate potential suspects for the incendiary fire.

Behaviors related to the classifications of motive may not be exclusive to one motive classification but may appear to overlap categories and to be similar for different motives. In these instances, it is important to obtain additional information that may clarify the behaviors.

In addition to the identification of a motive, other analyses should be considered that might assist in determining if a serial firesetter exists. Through the analysis of confirmed incendiary fires, trends or patterns in repetitive firesetting behaviors may be detected. The three principal trends that may be identified are geographic clustering, temporal frequency, and methods and materials. (*See 19.4.1.*)

19.4.8.1 Motive Versus Intent. There is an important distinction to be made between motive and intent. *Intent* refers to the purposefulness or deliberateness of the person's actions, or in some instances, omissions. It also refers to the state of mind that exists at the time the person acts or fails to act. Intent is generally necessary to show proof of crime. The showing of intent generally means that some substantive steps have been taken in perpetuating the act. *Motive* is the reason that an individual or group may do something. It refers to what causes or moves a person to act or not to act and the stimulus that causes action or inaction. Motive is generally not a required element of a crime.

For example, a person with indications of "financial difficulty" could experience a fire to his insured property that is ignited by his falling asleep with a lit cigarette. While this person may have motive to cause a fire, that person did not intend to have a fire. Thus, no element of intent existed.

19.4.8.2* Classifications of Motive. The classifications discussed in this chapter are those identified in Douglas et al., *Crime Classification Manual* (CCM). The CCM uses a diagnostic system intended to standardize terminology and formally classify the critical characteristics of the perpetrators and the victims of the three major violent crimes: murder, arson, and sexual assault.

The CCM identifies analytical factors that have been identified as essential elements in order to classify the motive of an offense. These factors include information about the victim,

the crime scene, and the nature of the victim–offender exchange. Not all the information will, or should be expected to be present in every case. The intent is to provide the fire investigator with as much information as possible.

The behaviors that may identify a possible motive, and thus a possible suspect, apply whether the fire is the result of a one-time occurrence or multiple occurrences, such as with a repetitive or serial firesetter. There are three classifications of repetitive firesetting behavior. These are identified as serial arson, spree arson, and mass arson. The terminology used in classifying a repetitive firesetter is similar to the terminology used in murderers. *Serial arson* involves an offender who sets three or more fires, with a cooling-off period between the fires. *Spree arson* involves an arsonist that sets three or more fires at separate locations with no emotional cooling-off period between fires. *Mass arson* involves an offender who sets three or more fires at the same site or location during a limited period of time.

The numerical classifications, which appear in the parentheses behind the classifications and the subclassifications, correspond with the classifications of the *Crime Classification Manual*.

The National Center for the Analysis of Violent Crime (NCAVC) has identified the six motive classifications as the most effective in identifying offender characteristics for firesetting behavior, as follows:

- (1) Vandalism
- (2) Excitement
- (3) Revenge
- (4) Crime concealment
- (5) Profit
- (6) Extremist

19.4.8.2.1 Vandalism. Vandalism-motivated firesetting is defined as mischievous or malicious firesetting that results in damage to property. Common targets include educational facilities and abandoned structures, but also include trash fires and grass fires. Vandalism firesetting categories include the following.

(a) *Willful and Malicious Mischief.* These are incendiary fires that have no apparent motive or those that seemingly are set at random and have no identifiable purpose. These are fires that are often attributed to juveniles or adolescents.

(b) *Peer or Group Pressure.* Recognition or pressure from peers is sometimes regarded as a reason for firesetting, particularly among juveniles.

19.4.8.2.2* Excitement. The excitement-motivated firesetter may enjoy the excitement that is provided by actual firesetting or the activities surrounding the fire suppression efforts, or may have a psychological need for attention. The excitement-motivated offender is often a serial firesetter. This firesetter will generally remain at the scene during the fire and will often get in position to respond to, or view the fire and the surrounding activities. The excitement-motivated firesetter's targets range from small trash and grass fires to occupied buildings.

The excitement-motivated firesetter includes the following subcategories.

(a) *Thrill Seeking.* Setting a fire provides this offender with feelings of excitement and power. The thrill-seeking firesetter is often a repetitive firesetter, who compulsively sets fires to satisfy some psychological desire or need.

(b) *Attention Seeking.* These firesetters have a need to feel important, and they set fires in order to satisfy a psychological need.

(c) *Recognition.* These firesetters are sometimes described as the hero or vanity firesetter. These firesetters often remain

at the fire scene to warn others, report the fire, or assist in fire-fighting efforts. They enjoy or may seek the recognition and praise they receive for their efforts. Typical among these firesetters are security guards and fire fighters. Occasionally these firesetters may even take responsibility for the setting of the fire.

(d) *Sexual Gratification or Perversion.* These are firesetters who set fires as a means of sexual release. The firesetter in this category is considered rare.

Attention-seeking, recognition, and sexual-gratification firesetters rarely attempt or intend to harm people, but these firesetters may disregard the safety of innocent bystanders or occupants. However, the thrill-seeking offender, whose compulsion requires the inherent sense of satisfaction, will often set a big fire, or a series of bigger fires. Fires will typically involve structures, but when vegetation is involved, these fires are also large.

19.4.8.2.3* Revenge. The revenge-motivated firesetter retaliates for some real or perceived injustice. An important aspect is that a sense of injustice is perceived by the offender. The event or circumstance that is perceived may have occurred months or years before the firesetting activity. A fire by the revenge-motivated offender may be a well-planned, one-time event or may represent serial firesetting, with little or no pre-planning. Serial offenders may direct their retaliation at individuals, institutions, or society in general.

Subcategories of revenge firesetting include the following.

(a) *Personal Retaliation.* The triggering event for this motive may be an argument, a fight, a personal affront, or any event perceived by the offender to warrant retaliation. Favorite targets include the victim's vehicle, home, or personal possessions. The specific location and the materials involved in the fire may be a significant factor in identifying the offender. Igniting clothing or other personal possessions is seen as a more personal affront to the victim than simply setting a fire in a common area. The fire scene may also be vandalized. These fires may be a one-time event or an act of serial arson.

(b) *Societal Retaliation.* This offender usually suffers from a feeling of inadequacy, loneliness, persecution, or abuse. The societal retaliation offender generally is not satisfied with a single fire or even a series of fires. Therefore, this serial offender is likely to set many more fires than other revenge-motivated firesetters.

(c) *Institutional Retaliation.* This classification of offender targets institutions such as religious, medical, governmental, and educational institutions, or corporations. The firesetter may be a disgruntled employee, a former employee, a customer, or a patient.

(d) *Group Retaliation.* Targets for group retaliation may be religious, racial, fraternal, or other groups, including gangs. Graffiti, symbols or markings, and other vandalism may accompany the fire.

19.4.8.2.4* Crime Concealment. This category involves firesetting that is a secondary or a collateral criminal activity, perpetrated for the purpose of concealing the primary criminal activity. In some cases, however, the fire may actually be part of the intended crime, such as revenge. Many people erroneously believe that a fire will destroy all physical evidence at the crime scene. Categories for crime concealment firesetting include the following.

(a) *Murder Concealment.* This scenario is where a fire is set in an attempt to conceal the fact that a homicide has been committed, to destroy forensic evidence that may identify the offender, or to conceal the identity of the victim.

(b) *Burglary Concealment*. This is a fire that is set in an attempt to conceal the fact that a burglary has occurred or to destroy forensic evidence that may identify the offender.

(c) *Destruction of Records or Documents*. This is a fire that targets records or documents. These fires may involve files ignited still in their folders or an origin inside a file cabinet. It may involve ordinary combustibles located in an exposure position to the files, such as a trash can moved adjacent to the files. Potential suspects in these incidents involve those who have some interest in the documents or records that were targeted.

19.4.8.2.5* Profit. Fires set for profit involve those set for material or monetary gain, either directly or indirectly. The direct gain may come from insurance fraud, eliminating or intimidating business competition, extortion, removing unwanted structures to increase property values, or from escaping financial obligations.

The broad category of fraud is frequently identified as an arson motive. However, fraud is classified as a subcategory in the profit motive category. Fraud-motivated fires may include commercial or residential properties. Commercial fraud fires may be set or arranged by an owner to destroy old or antiquated equipment, to destroy records to avoid taxes or audits, or for the purpose of obtaining insurance money. Fires may be set by a competitor to gain market advantage, or by agents of organized crime for purposes of extortion, protection rackets, or intimidation. Residential fraud may include an owner intending to defraud an insurance carrier, or a tenant defrauding an owner or a welfare agency. Increasing taxes, physical deterioration (and legally mandated repairs such as by code enforcement agencies), vacancy or inability to rent, or statutory rent-control measures may be reasons for a landlord to consider burning the structure.

There are several subcategories that further identify fraud as a motive. These include fraud to collect insurance, fraud to liquidate property, fraud to dissolve a business, and fraud to conceal a loss or liquidate inventory. The other categories include employment, parcel/property clearance, and competition.

19.4.8.2.6* Extremism. Extremist-motivated firesetting is committed to further a social, political, or religious cause. Fires have been used as a weapon of social protest since revolutions first began. Extremist firesetters may work in groups or as individuals. Also, due to planning aspects and the selection of their targets, extremist firesetters generally have a great degree of organization, as reflected in their use of more elaborate ignition or incendiary devices. Subcategories of extremist firesetting are identified as follows.

(a) *Terrorism*. The targets set by terrorists may appear to be at random; however, target locations are generally selected with some degree of political or economic significance. Political targets generally include government offices, newspapers, universities, political party headquarters, and military or law enforcement installations. Political terrorists may also target diverse properties such as animal research facilities or abortion clinics. Economic targets may include business offices, distribution facilities of utility providers (e.g., atomic generation plants), banks, or companies thought to have an adverse impact on the environment. Fires or explosions become a means of creating confusion, fear, or anarchy. The terrorist may include fire as but one of a variety of weapons, along with explosives, used in furthering his or her goal.

(b) *Riot/Civil Disturbance*. Intentionally set fires during riots or civil disturbances may be accompanied by vandalism and looting. It is worth noting that all fires ignited during peri-

ods of civil unrest may not be the result of the extremist firesetter but may be set by others, such as owners, hoping that the fire is attributed to the extremist firesetter and the circumstances surrounding the civil disturbance.

Chapter 20 Fire and Explosion Deaths and Injuries

20.1 General. Fire and explosions exact a high toll in deaths and injuries, and the investigator must be prepared to make special efforts when they occur. Since fire and explosion injuries can lead to death hours, days, or even weeks after the event, every fire and explosion that involves serious injuries should be investigated in the same way as a fire and explosion that has immediate fatalities. While there is considerable overlap between fire deaths and fire injuries, they will be considered separately.

20.2 Death Scene Considerations. There are a number of considerations to be made before the investigation of a fatal fire or explosion even begins that can have a significant impact on the length and success of the investigation. Any time a fire death occurs, or a death resulting from injuries received as a result of a fire or explosion occurs, an autopsy should be performed.

20.2.1 Fire Suppression. Fire suppression personnel should be made aware that the use of straight-stream hose streams can disturb fragile evidence such as clothing and can alter a badly charred body. As soon as a body is discovered, and it is determined that the victim is beyond medical aid, every effort should be made to minimize fire-fighting operations in close proximity to the victim, including foot traffic, hoses, and equipment. Of course, if there is any chance of resuscitation, the survival of the victim must take priority. It might be thought advantageous to remove a body as soon as it is found so that operations are not impeded, but it is beneficial to the entire fire-death investigation if the body is left in place until it can be properly documented and examined. Only severe emergency conditions, such as imminent collapse of the building or uncontrollable fire in the vicinity, should force premature removal of the body.

20.2.2 Documentation. As soon as conditions permit, photographic documentation of the body or body parts and their surroundings should be carried out. If the body has to be moved due to emergency considerations, a few photographs may make the difference between a successful investigation and failure. The photographs should be taken on color, 35 mm or large-format still film with a good-quality camera and a suitable electronic flash. Video recordings or instant-photo films may not provide adequate detail but may be used as a supplement or in the absence of other images. Either slides or prints are suitable, but print negatives expedite the process of making prints for court displays. Because fire patterns or blast effects on clothing and on the body may be important evidence, photographs should be taken of all exposed surfaces of the body before the debris is disturbed and then again during searching and layering operations. The body should be photographed while it is being moved, to record any changes incurred by the removal process. In this situation, videotaping may be beneficial. After the body is removed, the location where it was found should be photographed along with the body before it is unclothed, as well as after removal of clothing. Any burns or other injuries should be photographed in close-up with a suitable scale in the field of view.

Diagrams and sketches should supplement photos. Diagrams can show hidden details. They can record the dimensions of features of the scene and can document distances between the body (and its extremities) and furnishings, walls, doors, windows, and other features (see Figure 20.2.2). The outline of the body should be recorded on a diagram and should be traced on the floor in chalk, tape, or string so that it can be referred to in later stages of the scene examination.

FIGURE 20.2.2 Diagram showing location of body in relationship to room and furnishings.

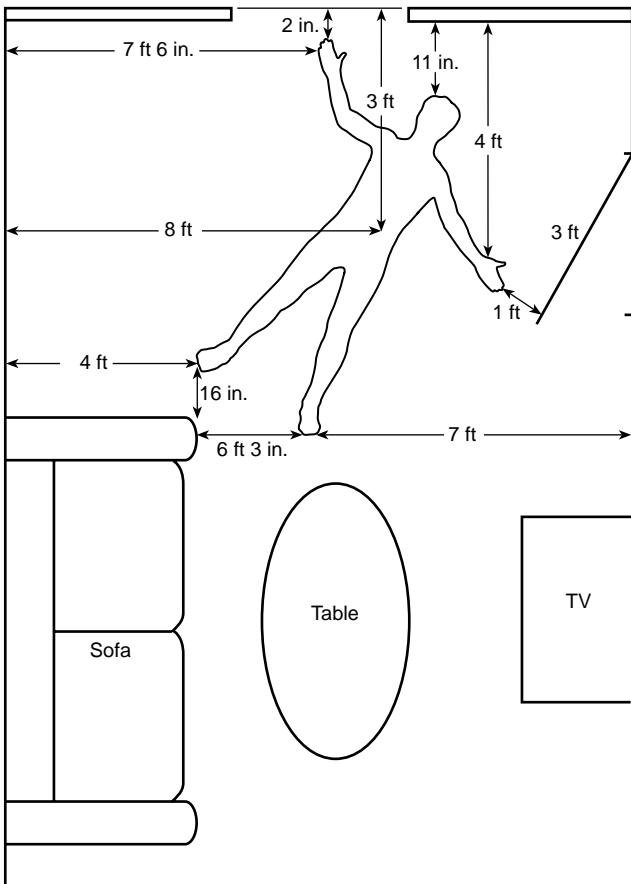

Note: Not to scale. For SI units, 1 in. = 2.54 cm; 1 ft = 0.3 m.

See Chapter 13 for additional information on documentation.

20.2.3 Notification. In death investigations, there are legal and procedural requirements for notifying the necessary authorities, including police, coroner, medical examiner, and forensic lab, that vary from jurisdiction to jurisdiction. These requirements may involve both civil and criminal agencies, and the investigator should understand these steps prior to beginning the investigation.

20.2.4 Recovery of Bodies and Evidence. A proper death investigation is a team effort, and may involve the investigator, homicide detective, and forensic pathologist. All parties should be prepared to work side by side at the scene to ensure that all critical evidence is recovered, whether the death is determined to be accidental or otherwise. If there are indications of foul play or if the body is very badly burned, the investigator should consider special assistance in the form of a criminality (forensic scientist)

with crime scene experience, a forensic odontologist, or a forensic anthropologist.

The search for evidence tends to focus on the body with a realization that, in any death investigation, critical evidence is often recovered within arm's reach of the body. The body is a convenient reference point, but it should be remembered that evidence may be elsewhere in the vicinity, so a careful search must be made of the entire room or area. To aid in the search, this area should be marked off into sectors by string, tape, rope, or chalk, as shown in Figure 20.2.4. A grid system may be developed to conduct the investigation by dividing the scene into specific areas. The search in each grid needs to be documented and the evidence from each grid identified. The geometry of the scene may determine the grid system, such as by floor or by room. Other methods include spiral, strip, or area searches. Regardless of the method used, the assigned search areas should overlap to ensure complete coverage.

FIGURE 20.2.4 An example of a room that has been marked off into sectors.



The sequence of events of death, fire, explosion, and collapse may be revealed by the sequence of layers in the debris (ceiling, furniture, body, floor covering, etc.) and by noting where the fire damage has occurred. An unburned body found on an unburned sofa beneath a collapsed ceiling and roof structure is a lot different than a burned body found under a burned sofa with a ceiling collapsed on top. The search through each sector proceeds through the layers of debris as they are found. The debris from each sector can be removed to a location where a more detailed search can be carried out by

other searchers, using sieving through a series of sifting screens. Such screens are typically made of 1 in., 1/2 in., 1/4 in., and window screen wire mesh (hardware cloth) fitted to wooden or metal frames.

When the body is removed (often after the detailed search has been carried out in the sectors surrounding it), all debris associated with or adhering to the body should be transported in the body bag and preserved for trace evidence, volatiles, weapons, projectiles, and the like. The area under the body should then be carefully searched for evidence that has fallen loose while the body is being moved.

20.3 Death-Related Pathological and Toxicological Examination. There are a number of examinations that can be conducted on the victim that may yield information of value to an investigator.

20.3.1 X-rays. X-rays made of the entire body and all associated debris can be extremely beneficial. These can be supplemented with dental X-rays and detail X-rays of anatomic features (broken bones, wounds, etc.). Fluoroscopy, while convenient, does not capture the same detail as an X-ray and provides no permanent image.

20.3.2 Carbon Monoxide Levels. Carbon monoxide levels in blood and tissue are the most common postmortem tests because they can reveal a lot about the cause of death. Carbon monoxide causes a cherry-pink coloration to the skin that may not be visible in dark-skinned individuals or ones that are heavily soot covered. The coloration may be visible in the skin, lips, and nipples, as well as in the liquid blood, in areas of post-mortem lividity, and in the internal organs. The coloration in internal organs will remain when the organ is preserved in formalin, when normal tissue turns a muddy gray-brown color. The carbon monoxide saturation in the blood (carboxyhemoglobin, percent COHb) and tissue may be measured by a chemical assay or by a gas chromatographic method. If possible, carbon monoxide saturation should be measured for every fire victim.

20.3.3 Presence of Other Toxic Products. The presence of toxic products such as hydrogen cyanide or hydrogen chloride (from combustion products) or other organic or inorganic poisons is determined by chemical or instrumental analysis of blood, brain, or organ tissue. The levels of alcohol, pharmaceutical drugs, or drugs of abuse are determined by gas chromatography/mass spectrometry, liquid chromatography, or immunoassay techniques. Most of these assays are carried out on liquid blood, but in severely burned bodies, there may not be enough liquid blood, so other body fluids or tissue samples may be used. Blood samples must be drawn from a blood vessel and not from the abdominal cavity if their analysis is to be reliable.

20.3.4 Smoke and Soot Exposure. Evidence of smoke or soot in the lungs, bronchi, and trachea (even esophagus) is one of the most significant factors in confirming that the victim was alive and breathing smoke during the fire. This finding requires that the trachea be transected over its entire length. Soot in mouth or nasal openings alone may be the result of soot settling in openings and not of breathing. Knowing the position of the body when found may be critical to a correct interpretation. Soot may also be swallowed and found in the esophagus and stomach.

20.3.5* Burns. Burns may be induced by antemortem exposure to flames, hot surfaces, radiant heat, or hot gases or by postmortem radiant, convected, or conducted heat in the fire environment. Antemortem burns trigger a vital response,

including reddening and blistering, which involves cellular and chemical changes that may be detected after death. Burns that occur immediately prior to death may not have time to exhibit a vital response and may not be distinguishable from postmortem burns. Blistering can be produced postmortem.

Postmortem effects are dominated first by shrinkage due to dehydration of the muscle tissue. This shrinkage causes flexion, since the flexor muscles of the body are usually more massive than the extensor muscles. This flexion can produce the so-called *pugilistic attitude*. The crouching stance with flexed arms, legs, and fingers is not the result of any pre-fire physical activity (such as self-defense or escape) but a direct result of the fire. Bone fractures can result from such muscle contraction or as the result of extensive direct exposure to heat and flames.

Blood can seep from ears, nose, and mouth as a result of heating. Blood found external to the body can indicate antemortem physical trauma. Blood can percolate into the epidural space between skull and the dura (the tough lining of the skull), but not, as a rule, into the subdural space between the brain and the dura. This subdural hematoma results from injury only.

20.3.6 Consumption of the Body by Fire. The investigator should remember that the body is part of the fuel load of a burning room. That is why the burn patterns on the body and any consumption of it have to be considered within the context of the entire scene and not in isolation. Aside from the clothing, there are three major combustible constituents to the body. Skin and muscle tissue is not a good fuel, but it will burn if heated enough to dehydrate it and then exposed to enough direct flame to consume it. It will char and undergo glowing combustion if enough additional heat is provided. Fat is the best fuel on the body. Animal fat has a heat of combustion (DHc) of over 30 MJ/kg. It can be dehydrated by a modest flame, and then melted or rendered to support flames. While not readily combustible, bone adds to the fuel by supplying marrow and tissue as fuel. Living bone will shrink and shatter when heated, while its surface undergoes degradation to a flaky or powdery form, but it does not readily oxidize to calcium oxide. The skull can fracture (typically along the suture lines) or disintegrate when heated. Internal pressure caused by expansion of water in the brain tissue can cause the skull to explode.

Human bodies do not combust spontaneously. If fire conditions are appropriate, the body fat can render from a dead body to sustain a small but persistent flaming fire. If the body fat can be absorbed onto the rigid, absorbent char of upholstery, clothing, bedding, or carpet, the flames can be sustained in the manner of an oil lamp. The flames then promote dehydration and combustion of muscle tissues and internal organs and reduce bones to a flaky mass over a period of many hours. The fire thus sustained is small enough that other combustible fuels in the vicinity may not ignite by radiant or convected heat. The end result is a body most heavily burned away in the area where the most body fat is located (the torso) leaving the lower legs, arms, and often the head relatively unburned.

20.4 Fundamental Issues of Death Investigations. There are a number of fundamental issues that may confront the investigator involved in a death related to fire or explosion. These are listed in 20.4.1 through 20.4.6.

20.4.1 Remains Identification. In a very badly damaged body, the determination as to the remains being human or animal may not be as simple a matter as would first appear. Animals having the same mass as an adult, such as pigs, deer, or even large dogs, can be mistaken for human remains (and vice versa).

Badly charred remains of children or infants are even harder to identify, because their smaller mass and reduced calcification allows more destruction. While it is difficult to destroy the remains of an adult human in a structure or even vehicle fire, remains of infants can be consumed so completely as to defy identification. This critical identification may require the services of a physical or forensic anthropologist who is familiar with the anatomical characteristics of all species.

20.4.2* Victim Identification. The identification of victims can be carried out by a variety of means, depending on the extent of fire damage to the body. Identification by visual observation is most unreliable, for exposure to even a moderate fire induces tissue swelling and tightening of skin by shrinkage. Color changes to face and hair can make identification of a person and sometimes even estimation of age and race difficult. Visual observation should be used only as a starting point.

Clothing and personal effects should be used, like visual identification, only as a starting point. It is far too easy for clothes, wallets, rings, watches, and other personal effects (even dental plates) to be substituted onto another person prior to a fire. Fingerprints can be used with almost complete certainty if record prints are available for the person thought to be the victim. If even a small portion of unburned friction ridge skin remains on a fingertip, that may bear enough individual characteristics to permit comparison.

X-rays provide one of the surest means of identifying even badly burned bodies. The mass of the head tends to protect the teeth from most fire damage, and dental X-rays may be secured if even a tentative identification is made. The jaws must be resected and X-rays made by a qualified odontologist to replicate the positions and angles of whatever clinical antemortem X-rays are available. The shape and locations of fillings, bridges, and implants are then used to make the identification. In some cases, unusual root shapes or other irregularities have been used in the absence of dental work. X-rays of other parts of the body may yield previous fractures or other injuries or surgical procedures that can verify an identification. There are also custom-made joint implants, prostheses, and even pacemakers that can be identified.

DNA or serological typing can be conducted if family members are available to provide reference samples. These techniques can be used on even fragmentary remains if they have not been completely charred, and they are nearly as reliable a form of personal identification as fingerprints.

20.4.3 Cause of Death. The cause of death may be defined as the event, injury, or illness that caused the sequence of changes that ultimately brought about death. Examples of causes of death include smoke inhalation, burn (incineration), gunshot, trauma (explosion, structural collapse), but may be heart attack or illness (chronic or acute).

20.4.4 Manner of Death. The manner of death describes the general course of events or circumstances that brought about the cause of death (accidental, homicidal, suicidal, natural, or undetermined).

20.4.5 Victim Activity. An attempt should be made to determine the victim's activity before, during, and after the onset of the fire or explosion and at the time of death, including whether the person was alive and conscious. Factors that can assist the investigator in making these determinations include the following:

- (1) Location of the body (in bed, at exit)
- (2) Position of the body (in chair, hiding)

- (3) Clothing on the body (pajamas, work clothes)
- (4) Burn patterns on the clothing
- (5) Burn patterns on the body
- (6) Items found with the body (e.g., keys, telephone, flashlight, fire extinguisher, personal property)
- (7) Blast damage to the body (e.g., pressure, impact, and shrapnel)

The patterns of damage on the clothing and the body should be considered in context with the total fire or explosion patterns in the room or area. Apparent inconsistencies should be examined. Burn patterns to the clothing (e.g., cigarette burns) may reveal a history of involvement with previous fires. Burn patterns to the clothing or the body may indicate that an attempt had been made to fight the fire or may be evidence of firesetting. The relationship between the death and the fire should be investigated, because not all fire-related deaths are directly caused by heat, flame, or smoke. Examples include a person smoking a cigarette on a sofa who dies of a heart attack, a person jumping from a window to escape a fire, fatal trauma from building collapse, and homicide prior to the fire.

20.4.6 Postmortem Changes. Upon death, the circulation of blood ceases and the blood begins to settle in the blood vessels and capillaries into the lowest available portions of the body in response to gravity, over a period of hours. This settling produces a purple or red coloration in the tissues, called *lividity* or *livor mortis*. In the first few hours after death, if the body is moved and its position altered, lividity disappears from one area and will develop in the new lowest area. After 6 to 9 hours, lividity becomes fixed and no longer shifts if the body is moved. The areas of lividity can appear red if the victim died with a significant COHb level because of the bright red color of blood with a high COHb saturation. The presence, absence, and pattern of areas of lividity can help establish the position of the body after death and can reveal whether it has been moved or repositioned after death.

Over a period of hours after death, chemical changes in the muscle tissue cause it and the joints to stiffen in place. This is called *rigor mortis*. It develops first in the hands and feet, progressively involving the limbs, torso, and head. Its onset depends on the temperature of the body (and its environment) and the physical activity of the victim just before death. After 12 to 24 hours, the rigor passes, leaving the joints and muscles limber. Loss of the rigor proceeds from extremities to torso and head over a several hour period. Extreme muscular activity just prior to death and high environmental temperatures may hasten the onset (and often the loss) of rigor. Experienced forensic pathologists may use the progressive onset and loss of rigor to help establish an approximate time of death. Rigidity (and contraction) of muscles caused by exposure to fire is not the same as rigor mortis and does not leave the body with time.

20.5 Mechanism of Death. The combustion products arising from a fire are many and their effects on healthy individuals varied; however, none are without toxicological effects. The inhalation of these products or contact with skin or eyes can result in deleterious biological effects, such as immediate irritation of the eyes and respiratory tract or systemic effects that influence other functions of the body. These products include carbon monoxide, carbon dioxide, nitrogen oxides, halogen acids (hydrochloric, hydrofluoric, and hydrobromic acid), hydrogen cyanide, particulates (ash, soot), and aerosols (complex organic molecules resulting from pyrolysis products).

20.5.1* Carbon Monoxide. Carbon monoxide (CO) is produced at some level in virtually every fire. All carbon-based fuels (e.g., wood, paper products, plastics) produce carbon monoxide as a result of incomplete combustion. During burning of organic fuels, CO is initially formed and then subsequently oxidized to carbon dioxide (CO₂). In underventilated fires or in fires where the initial products of combustion mix with colder gases (such as in smoldering fires), conversion of CO to CO₂ can be halted, and CO can become a major product of combustion. In well-ventilated fires, the level of CO produced may be as little as a few hundred parts per million (i.e., 0.02 percent). However, in underventilated, smoldering, or postflashover fires, CO concentrations of 1 percent to 10 percent (10,000 ppm to 100,000 ppm) can be produced. Elevated CO concentrations can also develop during fire suppression.

Carbon monoxide is an anesthetic and an asphyxiant. When inhaled, CO binds with hemoglobin in the blood, creating carboxyhemoglobin (COHb), which is approximately 200 times more stable than oxyhemoglobin. Therefore, the blood can accumulate dangerous levels of COHb from even low CO concentrations in the air. Thus, COHb reduces the oxygen-carrying capacity of the blood, leading to asphyxiation. In addition, CO delivered to the cells can interfere with cell respiration, causing incapacitation or death. The effects of carbon monoxide inhalation usually can be reversed by breathing fresh air or oxygen. However, carbon monoxide can remain in the blood for many hours after exposure. Consequently, repeated or long-term exposures to low levels of CO can result in the accumulation of a lethal level of COHb in the blood.

Because carboxyhemoglobin is so stable, it can be readily measured in the blood of fire victims, even long after death. The average fatal level of blood CO is widely accepted as 50 percent COHb. However, research has shown that fire victims have died from CO exposure with a blood COHb level as low as 20 percent. Also, COHb levels as high as 90 percent have been measured in fire victims. Thus, a victim's COHb level is an important indicator of his or her fate in a fire. Victims with less than 20 percent COHb most likely died from other causes, such as a lack of oxygen, or burns (as indicated in the following material). In contrast, victims with COHb concentrations of 40 percent or higher are likely to have died from carbon monoxide alone or in combination with other factors (such as age, alcohol, or a heart condition) or may simply have been incapacitated sufficiently by carbon monoxide poisoning to be unable to flee the fire.

In assessing the significance of a victim's COHb level, it should be noted that smokers typically have a 4 percent to 10 percent COHb level as a result of smoking alone. Also, victims who were administered oxygen, prior to blood being drawn, may show a low COHb due to the oxygen. Therefore, knowledge of the time elapsed between removal from the fire and death and the dosage of any oxygen administered to the victim prior to blood sampling is important in assessing the significance of the victim's COHb level (see Section 20.8).

Studies have shown that most fire victims (75 percent to 80 percent) die from carbon monoxide poisoning, and that most of these people die remote from the room of fire origin. This occurs because most fires do not produce lethal levels of CO until postflashover (the exception is smoldering fires). Thus, victims of carbon monoxide inhalation are typically outside the initial fire room unless the fire resulted from smoldering ignition. However, during flashover, thermal injury and lack of oxygen can cause death before substantial concentrations

of COHb are developed. The same can occur if the victim is involved in a flash fire involving fuel gases or vapors.

20.5.2 Thermal Effects. Death or injury can result from the hot thermal environment of a fire. The two main thermal causes are hyperthermia and inhalation of hot gases.

20.5.2.1 Hyperthermia. Victims exposed to the hot environment of a fire, including high moisture content, are subject to incapacitation or death due to hyperthermia, especially if the person is active. The time duration and type of exposure can lead to either simple hyperthermia or acute hyperthermia.

Simple hyperthermia results from prolonged exposures (typically more than 15 minutes) to hot environments where the ambient temperature is too low to cause burns. Such conditions range from 80°C to 120°C (176°F to 248°F), depending on the relative humidity, and usually result in a gradual increase in the body core temperature. High humidity makes it harder for the body to dispel excess heat by evaporation and thereby accelerates the heating process. Core body temperatures above approximately 43°C (109°F) are generally fatal within minutes unless treated.

Acute hyperthermia involves exposure to high temperatures for short periods of time (less than 15 minutes). This type of hyperthermia is accompanied by burns. However, when death occurs shortly after exposure to severe heat, the cause of death is generally considered to be from a rise in blood temperatures rather than from burns.

20.5.2.2 Inhalation of Hot Gases. Inhalation of hot fire gases can result in death or injury. However, it is difficult to distinguish the effects of thermal inhalation burns from edema and inflammation caused by chemical irritants in smoke. A distinguishing characteristic of thermal inhalation burns is that they are always accompanied by external facial burns, as the temperatures are sufficient to burn skin and facial hair.

20.5.3 Other Toxic Gases. There are many toxic gases found in fire environments that can cause irritation and swelling (edema) sufficient to interfere with breathing. Hydrogen cyanide (HCN) can be produced during the combustion of wool, hair, or polyurethane foams. Hydrogen chloride (HCl) can be produced during the combustion of polyvinyl chloride (PVC) plastics. Acrolein is produced during the combustion of wood and other cellulosic products.

20.5.4 Soot and Smoke. Soot and smoke can contribute to fire deaths and injuries through several mechanisms. Hot soot particles can be inhaled and can cause thermal injuries leading to edema in the respiratory system. Soot particulate can also contain toxic chemicals and can provide inhalation and ingestion pathways for these toxins. Excessive soot can also physically block the airways, causing asphyxiation. Liquid aerosols (mists) of pyrolysis are often acidic, causing chemical edema, and are often very toxic, causing systemic failures upon inhalation.

20.5.5 Hypoxia. Hypoxia is a condition caused by breathing a reduced oxygen atmosphere. A reduced oxygen environment occurs in an enclosure fire as a natural consequence of the combustion process. There is little effect of reduced environmental oxygen down to 15 percent oxygen in air. However, as the oxygen concentration in inhaled air decreases from 15 percent to 10 percent, a gradual increase in respiration occurs, followed by disorientation and loss of judgment. As the oxygen concentration in the ambient environment decreases below 10 percent, unconsciousness occurs, followed rapidly by

cessation of breathing and death. This situation is aggravated by a high level of carbon dioxide in the air, which causes a substantial increase in the rate and depth of respiration.

It should be noted that neither carbon dioxide nor oxygen levels can be measured in the blood postmortem because their levels begin to change immediately upon cessation of breathing.

20.6 Postmortem Tests and Documentation. The following is a list of procedures found to provide valuable information in the postmortem examination of victims of fires, to help establish identity, cause, and manner of death. The fire investigator should encourage the tests listed in 20.6.1 through 20.6.7 to be conducted and the results provided to the appropriate authority. Information concerning emergency medical treatment provided to the victim prior to a declaration of death should be provided to the appropriate authority.

20.6.1 Blood. Blood (from major blood vessel or chamber of the heart, not from a body cavity) should be tested for the following:

- (1) COHb percent saturation in blood
- (2) HCN concentration
- (3) Blood alcohol level or concentration
- (4) Drugs (prescription, nonprescription, or illegal) presence and concentration
- (5) Poisons (when indicated)

20.6.2 Internal Tissue. When indicated, internal tissue (brain, kidney, liver, and lung) should be tested for the following:

- (1) Drugs
- (2) Poisons
- (3) Volatile hydrocarbons

20.6.3 External Tissue (Skin Near Burns). When indicated, skin excised should be tested for vital chemical or cellular response to burns (antemortem versus postmortem burns).

20.6.4 Stomach Contents. Activities prior to death, and possible time of death, may be established through assaying of stomach contents, which should be examined when indicated. Presence or absence of soot in the esophagus and stomach contents should be noted.

20.6.5 Airways. Full longitudinal transection of airways from mouth to lungs may reveal the presence and distribution of edema, scorching or dehydration, and soot and should be conducted where indicated.

20.6.6 Internal Body Temperature. Internal body temperature may be used to aid in establishing the time and mechanism of death and should be determined where indicated. The temperature may be elevated due to hyperthermia, antemortem condition, or postmortem exposure to radiant heat.

20.6.7 X-rays. In order to establish identity, X-rays may need to be taken of the entire body, plus details of teeth. X-ray examination, including the clothing and associated debris found near the body, may also reveal unusual items such as bullets or shrapnel.

20.6.8 Clothing and Personal Effects. Clothing and personal effects should be examined to document the type, material, brand, and burn patterns present. All clothing associated with the body should be collected, packaged, and preserved after appropriate X-rays and evaluation. These items should be collected in accordance with Chapter 14. If the presence of an ignitable liquid is suspected, the material should be collected in accordance with Section 14.5.

20.6.9 Photographs. At the time of the postmortem examination, any burns or other injuries should be photographed, including close-ups with a suitable scale in the field of view. Overall photographs of the victim before and after clothing is removed should also be taken.

20.6.10 Diagrams of Burns and Injuries. The location, distribution, and degree of burns or other injuries should be shown on a diagram such as Figure 20.6.10. Such documentation of the burn patterns may assist the investigator in determining the victims' activities and location during the fire. (See 20.7.2.3.)

FIGURE 20.6.10 Example of a chart that can be used to diagram injuries.

BODY DIAGRAM

Indicate parts of body injured:
 None Blisters (red marker) Burns (black marker)

Fire investigation data sheet/attachment: _____
 Body diagram: _____ Initials _____

20.6.11 Documentation of Major Physical Trauma and Wounds. Major physical trauma and wounds to the body, such as gunshot, fractures, blunt trauma, and knife wounds, should be examined and thoroughly documented.

20.6.12 Sexual Assault Evidence. Physical evidence of possible sexual assault should be collected in accordance with applicable regulations and procedures.

20.6.13 Collection of Other Physical Evidence. When possible, the investigator should be present when the postmortem examination (autopsy) is conducted, not only to ensure that appropriate observations are made, but also to be on hand to answer any questions that arise during the examination. Pathologists and medical examiners may have limited knowledge of fire chemistry, fire dynamics, or blast effects. In such instances the investigator can advise as to fire conditions in the

vicinity of the body. The investigator should ensure that physical evidence such as bullets, casings, explosive residue, knives, and other weapons found with the body, as well as body fluids, record fingerprints, and dental records, are appropriately collected, preserved, and analyzed.

20.7 Fire and Explosion Injuries. Since fire and explosion injuries can lead to death hours, days, or even weeks after the event, every fire and explosion that involves serious injuries should be investigated in the same way as a fire and explosion that has immediate fatalities. The clothing and injuries of people injured in a fire or explosion may constitute important physical evidence to the investigator, and the scene deserves the same careful examination whether death or injuries resulted.

20.7.1 Physical Evidence. Physical evidence from fires or explosions may extend beyond the body itself. Such evidence may be obvious (e.g., blood stains) or may be microscopic (e.g., hairs or fibers). This evidence may be found on such things as clothing or furnishings.

20.7.1.1 Clothing. Clothing of people injured in fires or explosions is likely to be removed by emergency personnel or by emergency room staff and then discarded. The clothing, including outer clothing, undergarments, shoes, and socks, should be collected and preserved. If there is a suspicion that ignitable liquids or explosives were involved, there may be residues present. In any case, the clothing should be collected and preserved in accordance with Section 14.5 and 18.13.3 for later analysis. The clothing items may indicate the activity of the wearer at the time of the fire or explosion. What the clothing is made of and how it is made may play a role in its ignitability by flaming or smoldering sources (loose long sleeves, fine fabrics, etc.). It may be important for the investigator to determine the ignitability, burning properties (char, melt, or both), or heat release rate of the clothing involved.

20.7.1.2 Furnishings. At the scene, the furnishings that appear to have been involved in the fire should be assessed for the same fire properties as clothing. The position and condition of the furnishings involved may indicate the activity of the victim at the time of the fire or explosion. The ignitability by smoldering ignition versus flaming sources should be evaluated. Furnishings may have shielded victims from the blast and may include explosive residue and shrapnel.

20.7.1.3 Ignition Sources. A search of the scene should be carried out to establish what ignition sources are found. Careful examination of these sources may reveal whether they were involved. Melted or charred residues of the clothing or furnishing involved may be found adhering to the ignition source.

20.7.1.4* Notification Laws. Many jurisdictions have reporting laws that require emergency or medical personnel to notify police or fire authorities when a person suffering from significant burns is treated. These laws are patterned after gunshot wound notification laws and have been found to be successful in identifying both victims of assault and abuse, as well as perpetrators of arson who are burned in the execution of their crime.

20.7.2 Medical Evidence (Burns). Evidence of burn injuries is often recorded in medical reports using terms with which the investigator should be familiar.

20.7.2.1 Degree of Burn. Degrees of burn describe the depth and seriousness of injury as follows:

- (1) First degree: reddened skin only (like simple sunburn)
- (2) Second degree: blistering
- (3) Third degree: full-thickness damage to skin
- (4) Fourth degree: damage to underlying tissue, charring

Alternate descriptions of degrees of burn to skin are *superficial*, *partial*, and *full-thickness* burns.

20.7.2.2 Body Area (Distribution). Burn damage to the body is often estimated by the medical community by the “rule of nines,” where the major areas are represented by increments of 9 percent as follows:

- (1) Front of torso, 18 percent
- (2) Right arm, 9 percent
- (3) Front of right leg, 9 percent
- (4) Rear of right leg, 9 percent
- (5) Head, 9 percent
- (6) Rear of torso, 18 percent
- (7) Left arm, 9 percent
- (8) Front of left leg, 9 percent
- (9) Rear of left leg, 9 percent
- (10) Genitals, 1 percent

A more precise distribution of skin surface to body area, which reflects the true proportions of the body, and which is sometimes used, is provided in Table 20.7.2.2.

Table 20.7.2.2 Percentage of Body Surface Area

Body Part	Infant	Child	Adult
Front of head	9.5	8.5	3.5
Rear of head	9.5	8.5	3.5
Front of neck	1.0	1.0	1.0
Rear of neck	1.0	1.0	1.0
Chest and abdomen	13.0	13.0	13.0
Genitalia	1.0	1.0	1.0
Back and buttocks	17.0	17.0	17.0
Front of arm and hand	4.25	4.25	4.75
Rear of arm and hand	4.25	4.25	4.75
Front of leg and foot	6.25	6.75	10.0
Rear of leg and foot	6.25	6.75	10.0

Note: Infant = up to age 4; child = age 5 to 10; adult = age 11 and above.

The total burned area of the body is sometimes used as a predictor of survivability, as indicated in the Figure 20.7.2.2. Whether the victim survives or not may dictate further investigation. This figure can be used for assessing the likelihood of survivability.

FIGURE 20.7.2.2 Mortality by percentage of body burned and age.

Body Area Burned (%)	Age (year)																
	0-4	5-9	10-14	15-19	20-24	25-29	30-34	35-39	40-44	45-49	50-54	55-59	60-64	65-69	70-74	75-79	80 +
93+	1	1	1	1	1	1	1	1	1	1	1	1	1	1	1	1	1
88-92	0.9	0.9	0.9	0.9	1	1	1	1	1	1	1	1	1	1	1	1	1
83-87	0.9	0.9	0.9	0.9	0.9	0.9	1	1	1	1	1	1	1	1	1	1	1
78-82	0.8	0.8	0.8	0.8	0.9	0.9	0.9	0.9	1	1	1	1	1	1	1	1	1
73-77	0.7	0.7	0.8	0.8	0.8	0.8	0.9	0.9	0.9	1	1	1	1	1	1	1	1
68-72	0.6	0.6	0.7	0.7	0.7	0.8	0.8	0.8	0.9	0.9	0.9	1	1	1	1	1	1
63-67	0.5	0.5	0.6	0.6	0.6	0.7	0.7	0.8	0.8	0.9	0.9	1	1	1	1	1	1
58-62	0.4	0.4	0.4	0.5	0.5	0.6	0.6	0.7	0.7	0.8	0.9	0.9	1	1	1	1	1
53-57	0.3	0.3	0.3	0.4	0.4	0.5	0.5	0.6	0.7	0.7	0.8	0.9	1	1	1	1	1
48-52	0.2	0.2	0.2	0.3	0.3	0.3	0.3	0.5	0.6	0.6	0.7	0.8	0.9	1	1	1	1
43-47	0.2	0.2	0.2	0.2	0.2	0.3	0.3	0.4	0.4	0.5	0.6	0.7	0.8	1	1	1	1
38-42	0.1	0.1	0.1	0.1	0.2	0.2	0.2	0.3	0.3	0.4	0.5	0.6	0.8	0.9	1	1	1
33-37	0.1	0.1	0.1	0.1	0.1	0.1	0.2	0.2	0.3	0.3	0.4	0.5	0.7	0.8	0.9	1	1
28-32	0	0	0	0	0.1	0.1	0.1	0.1	0.2	0.2	0.3	0.4	0.6	0.7	0.9	1	1
23-27	0	0	0	0	0	0	0.1	0.1	0.1	0.2	0.2	0.3	0.4	0.6	0.7	0.9	1
18-22	0	0	0	0	0	0	0	0.1	0.1	0.1	0.1	0.2	0.3	0.4	0.6	0.8	0.9
13-17	0	0	0	0	0	0	0	0	0	0.1	0.1	0.1	0.2	0.3	0.5	0.6	0.7
8-12	0	0	0	0	0	0	0	0	0	0	0.1	0.1	0.1	0.2	0.3	0.5	0.5
3-7	0	0	0	0	0	0	0	0	0	0	0	0	0.1	0.1	0.2	0.3	0.4
0-2	0	0	0	0	0	0	0	0	0	0	0	0	0	0.1	0.1	0.2	0.2

1 = 100% mortality; 0.1 = 10% mortality (from Bull, 1979).

20.7.2.3 Documentation. Documentation should include line art diagrams of distribution of burn injuries and color photographs. (See 20.6.10.) Photos should be taken as soon as possible after the injury (preferably, before significant treatment is under way). Medical treatment and healing will affect appearance; therefore, photos taken later in the healing process may be difficult to interpret. Removal of eschar (scar tissue formed over healing burn wounds), skin grafts, and incisions made to relieve pressure and allow flexibility can make burn areas look different (better or worse) than the original burns.

20.7.2.4 Mechanism of Burn Injury. Burns induced by chemicals or contact with hot liquids (scalds) may not be distinguishable from those induced by hot gases or flames. When radiant heating raises the temperature of the skin, the higher the radiant flux, the faster damage will occur. For instance, a heat flux of 2 kW/m² will cause pain after a 30-second exposure, while a heat flux of 10 kW/m² will cause pain after just 5 seconds. A flux of 2 kW/m² will not cause blisters, while 10 kW/m² will blister in 12 seconds. (See Figure 20.7.2.4.) A radiant heat flux of 20 kW/m² typically associated with flashover, is sufficient to cause severe burns or death by thermal exposure and to ignite clothing. Radiant heat, sufficient to cause burns, can be reflected from some surfaces. Heat can be transferred through clothing, causing burns to the underlying skin, without any readily identifiable damage to the clothing.

Conducted heat can be more dangerous than radiant or convected heat because the heat source is brought into more intimate contact with the skin than typically occurs with either radiant or convected heat transfer. Skin can be damaged when it reaches a temperature of 54°C (130°F). This exposure can result from immersion in water for 30 seconds at 54°C (130°F) or by immersion for only 1 second at 65°C (150°F). Clothing, especially heavier cellulosic fabrics like denim or canvas, can

transmit enough heat by conduction to cause skin burns even though the fabric does not exhibit any burning or charring.

The mass movement of hot gases involved in convective heating can produce similar increases in skin temperature.

FIGURE 20.7.2.4 Diagram showing incident radiant heat flux effect on bare skin.

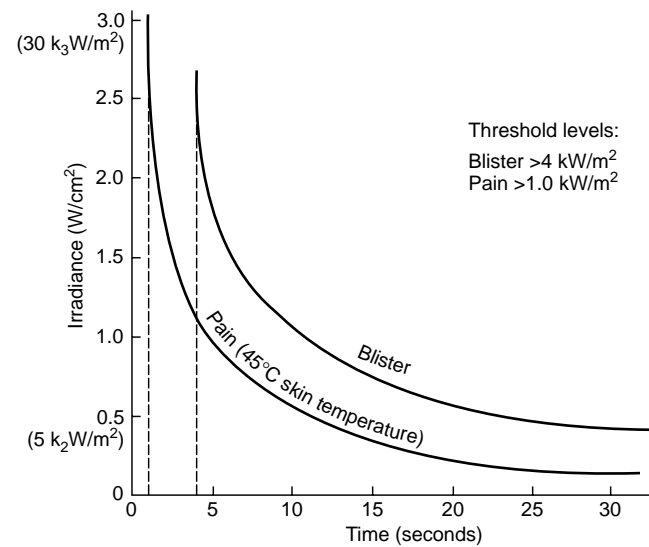

20.7.3 Medical Evidence (Inhalation). Like medical evidence concerning skin burns, medical evidence concerning inhalation exposure to toxic gases and heat can provide important information to the investigator to understand both the actions

of the injured individual as well as the fire environment to which the individual was exposed.

20.7.3.1 Sublethal Inhalation Exposure Effects on the Individual. Much of the information provided in Section 20.5 is also relevant to injuries, and the reader is referred to that section for additional information. The discussion here is limited to effects specific to sublethal effects of narcotic gases [carbon monoxide, hydrogen cyanide, oxygen-depleted air (hypoxia)], irritant gases (hydrogen chloride, acrolein, etc.), and smoke.

20.7.3.1.1 Narcotic Gases. Carbon monoxide, hydrogen cyanide, oxygen-depleted air (causing hypoxia) are all narcotic gases. Narcotic gases cause loss of alertness (intoxication), mental function, and psychomotor ability (the ability to carry out simple coordinated movements as are required in exiting a building). Carbon monoxide acts without the subject being aware of the extent of exposure and impairment. Hypoxia as a result of reduced oxygen concentration has a similar effect. Conversely, while hydrogen cyanide will ultimately result in mental depression and unconsciousness just as other narcotic gases, the effects of HCN exposure are more rapid and dramatic. At sublethal conditions, all these gases will reduce the ability of an individual to make decisions and carry out intended actions.

20.7.3.1.2 Irritant Gases. Irritant gases can alert people to the presence of a fire, even at low concentrations. Because of the unpleasant aspects of irritation of the eyes and respiratory tract, individuals may become aware of a fire earlier than would otherwise be the case, and may be motivated to escape. As the irritant effects become more pronounced, irritancy can have a direct impact on the ability of individuals to see and in this way may interfere with exiting behaviors. Post-fire effects of these irritants can be lung edema and inflammation.

20.7.3.1.3 Smoke. Visible products of combustion will impair the ability of individuals to see, and this in turn will reduce the speed of movement of escaping individuals. Sufficiently reduced visibility will cause individuals to not use an exit path. The extent of reduced visibility required to prevent the use of an exit path is dependent upon many factors, including the individual's familiarity with the building.

20.7.3.2 Hospital Tests and Documentation. Normally, upon hospital entry of a patient with fire-related injuries, a blood sample should be taken and analyzed for percent saturation of carboxyhemoglobin (percent of COHb), HCN concentration, blood alcohol, drugs, and blood pH to aid in the diagnosis and treatment of the individual. These measurements may be valuable in assessing the conditions of the individual at the fire scene and the fire environment to which the individual was exposed. In particular the percent of COHb is a valuable indicator. However, since the percent of COHb begins to be reduced as soon as the individual is removed from the fire environment, it is important that the blood sample be taken as soon as possible.

The rate at which CO is eliminated from the body is dependent on the oxygen concentration of the inhaled air. The concentration of CO in the blood will be decreased by one half (COHb half-life) in approximately 5 hours at normal air oxygen concentrations (21 percent by volume). COHb half-life is approximately 1 hour when a near 100 percent oxygen concentration is administered during emergency medical treatment. Because treatment and time can significantly reduce the measured percentage of COHb, the time from fire exposure to sampling of the blood for analysis and the treatment of the individual with oxygen by ambulance and hospital caregiv-

ers prior to sampling are important information, which the investigator should determine.

Other information of importance to the fire investigator is the condition of the airways. The presence of soot or thermal damage in the upper airways provides information about the fire environment to which the individual was exposed. Lung edema and inflammation can be indications of exposure to irritant gases.

20.7.4 Access to Medical Evidence. The fire investigator should be aware of the applicable legal protections regarding the confidentiality of medical records, and the appropriate methods for obtaining and safeguarding this confidential information.

20.8 Mechanism of Inhalation Injuries.

20.8.1 Elimination of CO by O₂/Air. The carboxyhemoglobin level of a fire survivor begins to decrease as soon as the person is removed from the fire environment. The rate at which CO is eliminated from the body is dependent on the oxygen concentration of the air being breathed. The concentration of CO in the blood (COHb saturation) will be decreased by one-half (COHb half-life), for example, reducing COHb from 45 percent to 22 percent in 250 minutes to 320 minutes at ambient O₂ levels in air (21 percent). COHb half-life is approximately 60 minutes to 90 minutes when a near 100 percent oxygen concentration is administered during emergency medical treatment. Hyperbaric oxygen treatment can reduce COHb half-life to approximately 30 minutes.

20.8.2 Explosion-Related Injuries. The location and distribution of explosion injuries to a victim can be useful in the reconstruction of the incident. These findings may indicate the location and activity of the victim at the time of the explosion, and they may help establish the location, orientation, energy, and function of the exploding mechanism or device. Explosion injuries can be divided into four categories based largely upon the explosion effect that caused them: blast pressure, shrapnel, thermal, and seismic.

20.8.2.1 Blast Pressure Injuries. The concussive effect upon a victim can cause internal injuries to various organs and body systems such as the gastrointestinal tract, lungs, eardrums, and blood vessels.

Frequently the blast pressure front is strong enough to violently move or even propel the victim into solid objects, or conversely, both low- and high-order damage (*see Section 18.3*) can violently move or propel large solid objects (walls, doors, etc.) into victims. These actions can cause blunt trauma injuries, fractures, lacerations, amputations, contusions, and abrasions.

Dirt, sand, and other fine particles can be blasted into unprotected skin, causing a type of injury commonly called *tattooing*.

With detonations, there may be violent amputations or dismemberment of the body caused by the blast pressure wave. Parts of the body or its clothing may be propelled great distances and should be searched for and documented.

20.8.2.2 Shrapnel Injuries. Shrapnel (solid fragments) traveling at high speeds from the epicenter of an explosion can cause amputations, dismemberment, lacerations or perforations resembling stab wounds, localized blunt trauma such as broken and crushed bones, and soft tissue damage.

20.8.2.3 Thermal Injuries. Thermal injuries associated with explosion flame fronts (and not the following fires, which often accompany low-order explosions) are usually of the first- and second-degree types because of their very short duration. Third-degree burns can also be encountered in these situations, but with much less frequency. These burns can be fatal.

Brief exposure to the high-temperature expanding flame front causes burn damage to the exposed skin surfaces. Often even a thin layer of clothing can protect the underlying skin from injury. Frequently, the burn injuries can be localized to the side of the body that is facing the expanding flame front. This finding can be used by the investigator as a heat and flame or explosion dynamics vector. Synthetic-fabric clothing may be melted by exposure to flash flames from deflagrations, where cotton fabrics may only be scorched.

20.8.2.4 Seismic Effect Injuries. The seismic effects of explosions are most dangerously manifested in the collapse of buildings and their structural elements. Injuries and deaths resulting from such occurrences are similar to what might be encountered by building damage from blast pressure waves.

Collapse of buildings can cause blunt trauma injuries, lacerations, fractures, amputations, contusions, and abrasions.

When examining victims of explosions, the investigator should take extreme care to scrutinize the body parts, clothing, and associated debris to find, document, and preserve items of evidence, such as clothing and any foreign objects found.

Chapter 21 Appliances

21.1 Scope. This chapter covers the analysis of appliances as it relates to the investigation of the cause of fires. The chapter concentrates on appliances as ignition sources for fires but, where applicable, also discusses appliances as ignition sources for explosions. This chapter assumes that the origin of the fire has been determined and that an appliance at the origin is suspected of being an ignition source. Until an adequate origin determination has been done, it is not recommended that any appliances be explored as a possible ignition source.

Addressed in this chapter are appliance components, which are common to many appliances found in the home and business. Sections of this chapter also deal with specific but common residential-type appliances and with how they function.

21.2 Appliance Scene Recording. The material presented in Chapter 13 should be used where appropriate to record the scene involving an appliance. Material presented in this section is supplemental and has specific application to appliances.

21.2.1 Recording Specific Appliances. Once a specific appliance(s) has been identified in the area of origin, it should be carefully examined before it is disturbed in any way. The appliance should be photographed in place from as many angles as possible. Photographs should be close-ups of the appliance as well as more distant photographs that will show the appliance relative to the area of origin, the nearest combustible material(s), and a readily identified reference point (e.g., window, doorway, piece of furniture). This reference point will greatly aid later reconstruction efforts in placing the exact location of the appliance at the time of the fire. If an appliance has been moved since the start of the fire, then the same photographs should be taken where it was found. If it can be established where the appliance was located at the time of the fire, such as by observing a protected area that matches the appliance base, or by talking to someone familiar with the fire scene prior to the fire, the appliance should be moved to its pre-fire location and the same photographs taken. This movement by the investigator may not be done until all other necessary documentation is completed.

21.2.2 Measurements of the Location of the Appliance. The scene should be photographed and diagrammed as described in Section 13.4. The location of the appliance within the area

of origin is particularly important. The investigator should take measurements that will establish the location of the appliance.

21.2.3 Positions of Appliance Controls. Special attention in the photography and diagramming should be paid to the position of all controls (e.g., dials, switches, power settings, thermostat setting, valve position), position of movable parts (e.g., doors, vents), analog clock hand position, power supply (e.g., battery and ac house current), fuel supply, and any other item that would affect the operation of the appliance or indicate its condition at the time of the fire.

21.2.4 Document Appliance Information. The manufacturer, model number, serial number, date of manufacture, warnings, recommendations, and any other data or labels located on the appliance should be documented. This information should be photographed, and notes should be taken, as these items may be difficult to photograph. Having notes will ensure that this valuable information is preserved. (*See Chapter 13 for additional information.*) It is frequently necessary to move the appliance to obtain these data, and this should be done with minimal disturbance to the appliance and to the remainder of the fire scene. In no case should the appliance be moved prior to completion of the actions in 21.2.3.

21.2.5 Gathering All of the Parts from the Appliance. Where the appliance has been damaged by the fire or suppression activities, every effort should be made to gather all of the parts from the appliance and keep them together. After exposure to fire, many of the components may be brittle and may disintegrate with handling, which is why it is important to document their conditions at this point. Where it is considered helpful and will not result in significant damage to the remains of the appliance, some reconstruction of the parts may be done for documentation and analysis purposes. This could include replacing detached parts and moving the appliance to its original location and position. Attempting to operate or test an appliance should not be done during the fire scene examination, as this may further damage the appliance, possibly destroying the critical clues within the appliance and its components. All testing at this point should be strictly nondestructive and only for the purpose of gathering data on the condition of the appliance after the fire. Examples of nondestructive testing include using a volt/ohmmeter to check resistance or continuity of appliance circuits.

21.3 Origin Analysis Involving Appliances. Chapter 4 and Chapter 15 deal with determining the origin of a fire in greater detail. The additional techniques and methodology presented here should be utilized when a fire involves an appliance. This is the case when the fire is confined to the appliance or when it is thought that a fire started by the appliance spread to involve other contents of the room.

21.3.1 Relationship of the Appliance to the Origin. It should be established that the appliance in question was in the area of origin. Those appliances that were clearly located outside the area of origin generally can be excluded as fire causes. In some cases, an appliance(s) remote from the area of origin may have something to do with the cause of the fire and should be included in the investigation. Examples of these are the use of an extension cord or the presence of a standing pilot on a gas appliance. Where doubt exists as to the area of origin, it should be classified as undetermined. When the origin is undetermined, the investigator should examine and document the appliances in any suspected areas of origin.

21.3.2 Fire Patterns. Fire patterns should be used carefully in establishing an appliance at the point of origin. Definite and unambiguous fire patterns help to show that the appliance was at the point of origin. Other causes of these patterns should be eliminated. The degree of damage to the appliance may or may not be an adequate indication of origin. Where the overall relative damage to the scene is light to moderate and the damage to the appliance is severe, then this may be an indicator of the origin. However, if there is widespread severe damage, other causes such as drop down, fuel load (i.e., fuel gas leak), ventilation, and other effects should be considered and eliminated. If the degree of damage to the appliance is not appreciably greater than the rest of the fire origin, then the appliance should not be chosen solely by virtue of its presence.

21.3.3 Plastic Appliance Components. Appliances that are constructed of plastic materials may be found at the fire scene with severe damage. The appliance may be severely distorted or deformed, or the combustible material may be burned away, leaving only wire and other metallic components. This condition of an appliance in and of itself is not an adequate indicator of the point of origin. This is especially true where there was sufficient energy from the fire in the room to cause this damage by radiant heating and ignition. Conditions approaching at, or following, flashover can have sufficient energy to produce these effects some distance from the point of origin.

21.3.4 Reconstruction of the Area of Origin. Reconstruction of the area of origin may be necessary to locate and document those patterns and indicators that the investigator will be using to establish the area of origin. As much of the material from the appliance as possible should be returned to its original location and then recorded with photographs and a diagram. The help of a person familiar with the scene prior to the fire may be necessary.

21.4 Cause Analysis Involving Appliances. The material presented in Chapter 16 should be used where appropriate to analyze an appliance that may have caused a fire. Material presented in this section is supplemental or has specific application to appliances.

21.4.1 How the Appliance Generated Heat. Before it can be concluded that a particular appliance has caused the fire, it should first be established how the appliance generated sufficient heat energy to cause ignition. The type of appliance will dictate whether this heat is possible under normal operating conditions or as a result of abnormal conditions. The next step is to determine the first material ignited and how ignition took place. The most likely ignition scenario(s) will remain after less likely or impossible ignition scenarios have been eliminated. If no likely ignition scenario exists, either accidental or intentional, then the cause should be classified as undetermined.

Patterns on the appliance may indicate the source of the ignition energy. However, hot spots or other burn patterns may be the result of other factors not related to the cause and need to be carefully considered. Patterns on nearby surfaces may provide information on the ignition source.

21.4.2 The Use and Design of the Appliance. The use and operation of an appliance should be well understood before it is identified as the fire cause. Some appliances are simple or very familiar to fire investigators and may not require in-depth study. However, appliance design can be changed by the manufacturer, or an appliance can be damaged or altered by the user, and, therefore, each appliance warrants investigation. More complicated appliances may require the help of special-

ized personnel to gain a full understanding of how they work and how they could generate sufficient energy for ignition.

21.4.3 Electrical Appliances as Ignition Sources. Many appliances use electricity as the power source, and electricity should be considered as a possible source for ignition. The material presented in Chapter 16 should be carefully considered and applied in this situation. Only under a specific set of conditions can sufficient heat be generated by electricity as a result of an overload or fault within or by an appliance and subsequently cause ignition.

21.4.4 Photographing Appliance Disassembly. When it is necessary to disassemble an appliance (or its remains) recovered from a fire scene, each step should be documented by photography. (*See 14.10.1.*) This is done to establish that the investigator did not haphazardly pull the artifact apart, causing pieces to be further damaged or lost. The documentation should show the artifact at the start and at each stage of disassembly, from multiple angles if possible, keeping careful track of loose pieces. Some investigators find it helpful to videotape this process. The investigator should have at least one specific reason for disassembling an artifact, and once an answer has been found, the disassembly process should stop. When an artifact cannot be easily disassembled or if the disassembly would be too destructive, the use of X-rays should be considered.

21.4.5 Obtaining Exemplar Appliances. To understand an appliance more fully, to test its operation, or to explore failure mechanisms, the investigator may need to obtain an exact duplicate (i.e., an exemplar). For this, the model and serial numbers may be required, and the manufacturer may need to be contacted to determine the history of this appliance. It may be that the manufacturer does not make the particular appliance any more or has changed it in some way. The investigator will need to determine whether the exemplar located is similar enough to the artifact to be useful.

21.4.6 Testing Exemplar Appliances. Exemplar appliances can be operated and tested to establish the validity of the proposed ignition scenario. If the ignition scenario requires the failure or malfunction of one or more appliance components, this can also be tested for validity on the exemplar. Where extensive or repeated testing is foreseen, the investigator will probably need more than one exemplar. The testing should show not just that the appliance is capable of generating heat, but that such heat is of sufficient magnitude and duration to ignite combustible material.

21.5 Appliance Components. Appliances are diverse in what they do and how they are constructed. Therefore, this section will provide a description of each of the common parts or components that might be found in various appliances. Where information is given in later sections about particular appliances, there will be references to the components that are used in those appliances.

21.5.1 Appliance Housings. Housings of appliances can be made of various materials. The nature of these materials can affect what happens to the appliances during fires and what the remains will look like after a fire. Most housings are made of metal or plastic, but other materials such as wood, glass, or ceramics might be found also.

Many appliances utilize painted steel finishes. This typically includes refrigerators, dryers, fluorescent fixtures, baseboard heaters, and the like.

Care should be exercised when evaluating heat damage patterns on painted steel surfaces. Many paints darken with heat exposure. Additional or greater heat exposure can cause some heat darkened painted surfaces to lighten in color. Further heat exposure may cause the paint to decompose to a gray or white powder. This gray or white powder can be disturbed or removed by fire fighting, handling, or by the formation of rust. An apparently lighter surface color may reflect more thermal damage than a darker area.

21.5.1.1* Steel. Steel is used for the housings of many appliances because of its strength, durability, and ease of forming. Stainless steel is used where high luster and resistance to rusting is needed, such as in kitchen appliances or wherever appearance and sanitation are important. Other types of steel may be used and coated with plastic or enamel to achieve the desired appearance. Galvanized steel may be used where resistance to rusting is needed but appearance is not important, such as inside a washing machine.

Steel will not melt in fires except under very unusual circumstances of extremely high temperatures for extended times. Ordinarily, steel will be oxidized by fires, and the surface will be a dull blue-gray. The brown rust color does not appear until the steel item has been wet long enough to rust. When steel is deeply oxidized by long exposure in a fire, the oxide layer often will be thick enough to flake off. In severe cases, the flaking off may go through the steel and create a hole. In fires of short duration, the surfaces of polished or plated steel can show various color fringes, depending on the degree of heating. After a fire, bare galvanized steel will have a whitish coating from oxidation of the zinc. Often, the surfaces of steel housings will have a mottled appearance ranging from blue-gray to rust to white to black to reddish. The odd colors are usually from residues of decorative or protective coatings on the steel in addition to the oxides. The particular colors and the patterns depend on many factors, and not much importance should be put on the color and patterns without substantiating evidence.

On rare occasions, a steel housing may be found with a hole made by alloying with zinc or aluminum. Most of the time, when one of these metals drips onto steel during a fire, the surface oxides keep the metals separated. During a long fire, the molten metal might penetrate the oxide layers and alloy with the steel. If there is need to know the cause of the hole, analysis of the steel at the edge of the hole would show alloying elements or absence of them.

A steel housing does not necessarily keep internal components from reaching very high temperatures. If a closed steel box is exposed to a vigorous fire for a long enough time, the inside of the box can become hot enough to cook materials, to gray ashes, or to melt copper.

21.5.1.2 Aluminum. Aluminum housings are commonly made from formed sheets or castings. Extruded pieces might be found on or in the appliance as trim or supports for other components. Aluminum has a fairly low melting temperature of 1220°F (660°C) if pure; alloys melt at slightly lower temperatures. The extent of damage to the aluminum housing can indicate the severity of the fire or heat source at that point.

21.5.1.3 Other Metals. Other metals, such as zinc or brass, might be used in housings. They would be likely to be just decorative pieces or to be supports for other components. Zinc melts at the relatively low temperature of 786°F (419°C) and so is almost always found as a lump of gray metal. Brass is used in many electrical terminals. Brasses have ranges of melting

temperatures in the neighborhood of 1740°F (950°C). Brass items are often found to be partly melted or just distorted after a fire. Because it is an alloy, brass softens over a range of temperatures rather than melting at a specific temperature.

21.5.1.4 Plastic. Plastic housings are used increasingly for a wide range of appliances that do not operate at high temperatures. Most plastics are made of carbon plus some other elements. Some plastics melt at low temperatures and then char and decompose at higher temperatures. Others do not melt but do char and decompose at higher temperatures. Nearly all plastics can form char when heated and will burn in existing fires. Many kinds of plastics will continue to burn by themselves if ignited. Other plastics will not continue to burn from a small ignition source at room temperature because of their chemical compositions or because of added fire retardants. Many plastic housings of recent manufacture have considerable fire retardant added, and they usually will not continue to burn from a small source of ignition. Each appliance in question would need to be checked for ease of burning of the plastic. In some cases, that check can be done by qualified personnel if enough of the material remains or if the identical appliance can be obtained.

After a brief fire, the plastic housing of an appliance may be melted and partially charred. If the pattern of damage shows that the heat source was inside, further examination of the remains is warranted. The plastics might show instead that the heat was from the outside and that the inside is less heated than the exterior. If the plastic housing has melted down to a partly charred mass, X-ray pictures can reveal encapsulated metal parts and wires. When a plastic housing has been mostly melted and burned by exterior fire, the underside of the appliance might still be intact or a metal base plate unheated.

When a fire is severe, all plastics might be consumed. Total consumption of the plastic does not by itself indicate that the fire started in the appliance.

Phenolic plastics are used for certain parts that must have resistance to heat, such as coffee pot handles and circuit breaker cases. Phenolics do not melt and will not burn by themselves. They can be consumed to a gray ash in a sustained fire. When a device that has been made with a molded phenolic body is moderately heated, the gray ash might be just a thin layer on the outside. Gray ash on the inside surfaces with little or no gray ash on the exterior may indicate internal heating.

When portions of an appliance melt and resolidify as a result of a fire, the direction of flow of the material can indicate the orientation of the appliance at the time that the melted component material cooled.

21.5.1.5 Wood. Wood still has occasional use in appliance housings. Wood can be fully consumed in a fire or can show a pattern of burning when only partly consumed. The pattern can help to show whether the fire came from inside or outside of the appliance.

21.5.1.6 Glass. Glass is used for transparent covers and doors on appliances. Glass might also be used in some decorations. Glass readily cracks when heated nonuniformly and can soften and sag or drip. Flame temperatures are higher than the softening temperatures of glass, so the degree of softening of glass is more a function of duration and continuity of exposure than of fire temperature.

21.5.1.7 Ceramics. Ceramics may be used for some novelty housings and are used as supports for some electrical components. Ceramics do not melt in fires, but a decorative glaze on them could melt.

21.5.2 Power Sources. Power sources for common appliances are usually the alternating current that is supplied by the power companies. There are a few other sources that will be considered. This section will not include voltages higher than 240 or three-phase power. For more detailed information on electrical power and devices, see Chapter 6.

21.5.2.1 Power Cords. Power companies in the United States supply electrical power at 60 Hz and 120/240 V ac (often called 110/220 V). Most appliances are designed to operate by plugging them into a 120 V outlet. Appliances that require more power, such as ranges and water heaters, operate at 240 V from the same electrical system in the structure.

Electrical cords that carry power to the appliance may be made of two or three conductors. The conductors are stranded to provide good flexibility. Some double insulated appliances and most appliances made before 1962 had only two-conductor cords. Newer large appliances usually have three-conductor cords with the third conductor for grounding as a safety feature. The stranded conductors of cords usually survive fires, but the remains will usually be embrittled if the insulation was burned away during the fire. Careless handling of brittle stranded conductors can cause them to break apart. Cords should be checked for arcing damage. See Chapter 6 for information on electrical conductors and damage to them.

Plugs for connecting the power cord to the outlet have somewhat different designs, depending on the amperage of the appliance. Plugs made prior to 1987 for 20 A or less were two straight prongs of the same width. Newer plugs have the neutral prong wider than the “hot” prong. The plug may have a third prong for grounding. Factory-made plugs have the conductors attached to the prongs inside a molded plastic body. That body may melt or be entirely burned away in a fire. The conductors and brass prongs will usually survive a fire, but sometimes the brass parts may be melted. After a fire with only minor burning near the plug, the face of the plug will be nearly unheated because of being protected against the receptacle. That finding can show that the appliance was plugged in. Also, even after a more severe fire, the prongs may be less oxidized where they were protected in the receptacle during the fire.

Plugs for higher voltages or amperages will have larger prongs and different positioning.

21.5.2.2 Voltages Less than 120. Many appliances that plug into a wall receptacle actually operate at 6, 12, or other voltages less than 120 V. Normally, a step-down transformer is used to produce the lower voltage. The transformer will usually be part of the appliance, but sometimes it is a separate unit that plugs directly into the receptacle and feeds the appliance with a thin two-wire cord. Shorting of wiring at 6 V is not likely to cause a fire, but it can do so under circumstances where the energy (i.e., heat) can be concentrated in a small area close to a combustible material.

21.5.2.3 Batteries. Batteries are used for portable appliances and some security devices. Batteries can range from car batteries to common dry cells to small button batteries for cameras and watches. Batteries provide about 1.5 V of direct current. Batteries of 6 V or 9 V are actually made of four or six dry cells, respectively, in one package.

Remains of batteries that were present in an appliance can usually be found after a fire. They usually will be damaged too much to indicate whether they provided power for ignition. However, what they were connected to could be important. One battery can provide enough power to ignite some materials under certain

conditions. In most battery-powered devices, though, the normal circuitry will prevent the energy of the battery from being sufficiently concentrated at one spot at one time to get ignition.

21.5.2.4 Overcurrent Protection. Protection against excessive, damaging current is provided by fuses or circuit breakers in many appliances. After a minor fire, the remains of the protective device might show whether it operated. After a severe fire, the metal parts of the protective device might be found to show at least that it was present.

The fusing element in a fuse can be one of several metals. In all fuses, the element has the proper cross section and electrical resistance for the temperature to rise to the melting point if current exceeds a specific level for a specified duration. If the excess current is moderate (e.g., less than twice the rating), the fuse element will melt without vaporizing. If the current is very high, as with a dead short, the element will usually partly vaporize to give an opaque deposit on a window or glass tube of the fuse.

Most circuit breakers operate thermally or magnetically, depending on the level of overcurrent. Above a specific current level, a bimetal strip deflects enough to let a spring pull the contacts apart. With an instantaneous high current, such as with a dead short, the magnetic field pulls the mechanism so that the contacts open. A circuit breaker that is in a fire environment can trip as the internal mechanism comes up to the activating temperature. Circuit breakers in appliances have a reset button.

21.5.3 Switches. Switches are used to turn appliances on or off and to change the operating conditions. Switches are found in a wide range of sizes, types, and modes of operation. Examination of switches after a fire can determine whether the appliance was on or off or other aspects of its operation. The remains of switches might be very delicate. Other than noting and documenting the positions of knobs, levers, or shafts or checking electrical continuity in place, it is recommended that the investigator not open, operate, or disassemble any switches. That job should be left to someone with technical expertise. (*See 14.10.1.*)

21.5.3.1 Manual Switches. Many switches are intended for the user to operate. These include on-off switches and those to change functions, wattage, or other features of the appliance. The design of the switches can include moving lever (e.g., toggle), push button, turning knob, or sliding knob. They have metal parts that can be examined after a fire. Where lightly damaged, the switch might still electrically test on or off or show which position it was in. Where severely damaged, the remains might show only whether the contacts were welded together. Switches will create a parting arc when they open. Therefore, apparent damage to the switch surface may be normal.

Electronic switches in many appliances may be too damaged by even minor fires to determine their pre-fire position or whether they malfunctioned. Examples of those switches include touch pads on microwave ovens and remote-controlled TVs.

21.5.3.2 Automatic Switches. Many switches in appliances are automatic and are not intended for the user to operate. Those switches generally keep the appliance operating within its design parameters and prevent unsafe operation. Those kinds of switches may be operated by electrical current, temperature, or motion.

21.5.3.2.1 Fuses and Circuit Breakers. Fuses and circuit breakers are automatic switches that operate by overcurrent. Circuit breakers can be reset, but fuses and fusible links need to be replaced.

21.5.3.2.2 Temperature Switches. Automatic switches that operate by temperature and are intended to keep the appliance operating within certain temperature limits are called *thermostats*. Automatic switches that are intended to prevent the appliance from exceeding certain parameters are called *cutoffs*, *limit switches*, or *safeties*.

Switches that operate by temperature can be based on expanding metal, bimetal bending, fluid pressure, or melting. These switches are usually used to prevent an appliance from operating outside a fixed range of temperatures or to prevent it from exceeding a set temperature (cutoff switches). They ordinarily have enough metal parts to be recognizable after a severe fire, although it may not be possible to determine whether the switch was functional at the time of the fire.

A few switches use expanding metal, where a long rod is positioned in the warm area. If that area becomes too hot, the rod expands and pushes contacts open. More common is the bimetal type, where two dissimilar metals are bonded together in a flat piece. One metal expands more than the other with increasing temperature, so while the temperature rises, the piece bends. That motion can open contacts to turn off the appliance. These switches are slow make-break, which is more likely to cause either erosion or welding of the contacts. After a severe fire, the bimetal may be bent far out of position, which is a result of heating from the fire and does not indicate a defective thermostat.

A bimetal disc operates on differential expansion, but the disc snaps from a dish shape in one direction to a dish in the other direction. The edge of the circular disc is fixed, and so the center snaps back or forth at particular temperatures to open or close the contacts.

Some switches operate by expansion of a fluid in a bulb that is located in the hot area. The pressure of that fluid is passed to bellows, often back at a control panel, through a metal tube, commonly copper. The bellows push open the contacts.

These various mechanical switches can be arranged either to open contacts so as to shut the appliance off, or to close contacts so as to turn something else on, such as a cooling fan, that will counter the high temperature. High-temperature cutoff switches may be present in an appliance, but they should not open the circuit except when the temperature becomes too high in the appliance. The contacts of switches should be examined by competent persons. If contacts in cutoffs are eroded by arcing from repeated opening, that can indicate that the appliance was operating in an overheated condition for an extended time, which may indicate a defect in the appliance.

Mechanical switches can fail by overloads, which overheat certain internal parts, or by welding of the contacts. The latter can happen at normal currents as slow make-and-break contacts pass current without being firmly in contact. Poor connections internally, such as where wiring is attached or where brass parts are riveted, can cause destructive heating and failure of the switch. The faces of contacts of thermostats will normally be somewhat pitted because they open and close frequently. Faces of contacts in devices used as safety cutoffs should not be significantly pitted, because the devices should not operate except when there is overheating.

The contacts of a switch are more subject to surface pitting, erosion, and possibly welding when they slowly open and close. For that reason, most switches, especially for carrying substantial currents, are made to snap open or closed. That can be accomplished with a bimetal disc, a flat spring, or a magnet. When welded contacts are found after a fire, that fact does not by itself prove that failure of the switch caused the fire. Heat

damage in the appliance could have caused a current surge if power were still available. Electrically welded contacts will have normal shapes, but the faces will be stuck together. If the contacts are found melted together into one lump, the cause is more likely to be severe fire exposure. The contacts are made of metals that have melting temperatures lower than that of copper, and they may melt together from fire exposure.

There are some cutoff devices that operate by internal melting of a material, which lets a spring push the contacts open. These are single-use devices that should be replaced if they operate, although they are sometimes deliberately bypassed, allowing the appliance to operate without protection. The appliance should be checked to verify the presence of such a device, and the device should be checked for signs of tampering or a history of previous replacement.

Many appliances have switches that operate from motion of some part of the appliance. Limit switches on appliances that have moving parts are intended to keep the part from moving too far. Forced-air furnaces may have a switch that operates by airflow pushing a vane up to allow the furnace to continue. Major appliances often have door switches, either to turn the appliance off as the door is opened, or to turn a light on. Motors in major appliances can usually have a centrifugal switch to disengage the starting winding as the motor comes up to speed. Those switches also may control a heating circuit so as not to allow heating unless the motor is running. As with all switches that operate from some mechanical action, these switches can fail to operate if the components that they depend on become misaligned or if the switch comes loose in its holder.

Many portable electric heaters have a tip-over switch that often is built into the thermostat. The switch has a weighted arm that hangs down and opens the contacts if the appliance is tipped so that the arm is not in its normal position.

21.5.4 Solenoids and Relays. Solenoids and relays are used in appliances to control a high-power circuit with one of lower power and often of low voltage. Activation of the low-power circuit energizes a coil or an electromagnet that causes an iron shaft or lever to move. That motion opens or closes the high-power circuit. Remains of solenoids or relays normally remain after a fire. Severe damage might make it impossible to determine whether they were operational or which position they were in at the time of the fire. The contacts should be examined to find whether they were stuck together during the fire.

21.5.5 Transformers. Transformers are used to reduce voltages from the normal 120 V and to isolate the rest of the appliance from the supply circuit. Some transformers are energized whenever the appliance is plugged in, so that the primary windings are always being heated by some amount of current. In other appliances, the transformer is not energized until the switch is turned on. The appliance is designed to keep heating of the transformer at a minimum under normal electrical loads. However, with long-term use, and if ventilation of the appliance is restricted, the temperature may increase and deteriorate the windings. As windings begin to short to each other, the impedance drops and more current flows, causing greater heating. That can lead to severe heating before the windings either fail by melting the wire or create a ground fault that could open the circuit protection. In some cases, the heated insulation or other combustibles in or on the transformer might be ignited before the electrical heating stops.

Appliance transformers are usually made of steel cores and copper windings, both of which will survive fires even when severely heated. Examination of a transformer from a burned

appliance might show that the interior windings are less heated and might even be of bright copper color. That finding shows that the heating was external and not from the transformer itself. A transformer from a severely burned appliance might have the windings baked to where they have the appearance of oxidized copper, with no surviving insulation down to the core. The remains of the windings would be somewhat loose on the core. That can happen from long exposure in any fire and does not prove that the windings overheated and caused the fire. Overheating of the windings can be determined when there is a clear pattern of internal heating, arcing turn to turn, and a pattern of fire travel out from that source. It is possible for a transformer to overheat even when protected by a fuse, because the fuse should have a sufficient electrical rating to carry the operating currents plus a safety factor.

Some transformers may be totally enclosed in steel and would not be likely to be able to ignite adjacent combustibles before being turned off by protection or internal failure. Other transformers are open and often have paper and plastics, which can be ignited, in their construction.

Fluorescent light ballasts are essentially transformers. The ballasts in indoor fixtures made after 1978 are required to have thermal protection. After 1990, thermal protection was required in ballasts for all fluorescent light fixtures (indoor and outdoor). This is indicated by a *P* on the label or stamped into the metal case. The pitch or potting compound from inside of the ballast will usually ooze out, either from internal heating or from fire exposure. Ballasts are usually enclosed in a steel body of the fixture. Any pitch that oozes out from internal heating of the ballast will mostly be caught in the enclosure. Pitch that does drip out of the fixture will not ignite other materials unless the pitch is already burning.

21.5.6 Motors. Motors are common in appliances to provide mechanical action. They generally range from $1/3$ hp to $1/4$ hp motors in washing machines or other large appliances to tiny motors in small devices. Most common motors are designed to operate at certain speeds. If the rotor is stopped while the motor is still energized, the impedance falls, and current flow increases. That can cause the motor windings to get hot enough to ignite the insulation and any plastics that are part of the construction.

Motors often have protection built into them that is intended to stop the current if the temperature gets too high for safe operation. That protection can be in the form of a fuse link, a single-acting thermal cutoff (TCO), a self-resetting thermal protector, or a manual resettable thermal protector. Some motors have both a resettable thermal protector and a single-acting TCO in them. A suspected motor and any protective device should be examined by competent personnel before deciding whether the motor caused the fire.

Windings of motors can be examined to find whether they are relatively unheated inside, which would indicate that heating came from the outside. If the windings are thoroughly baked, with oxidized strands all through, but materials around the motor are not so thoroughly heated, that indicates that the windings overheated. If there is much fire around the motor, the windings are likely to be thoroughly baked, whether the fire started in the motor or not.

Small motors that drive cooling fans or other devices are usually not sources of ignition. They do not have enough torque to generate much heat by friction. Some small motors are enclosed in metal cases, making ignition by internal heating unlikely. Shaded pole motors are often of open construction and could ignite combustibles that are in contact with them, if the windings get hot enough.

21.5.7 Heating Elements. Heating elements can be expected to get hot enough to ignite combustibles if the combustibles are in contact with the element. The design and construction of the appliance will usually keep combustibles away from the element. An exception is in cooking appliances, where the hot element is exposed for use. Elements can be sheathed, as is found in ovens and ranges, or they can be open wires that can get orange-hot during use. Open heating elements are usually wires or ribbons made from a nickel-chromium-iron alloy. Those that are designed to operate at glowing temperatures will get a dull gray surface oxide layer. In some appliances, a fan removes heat from the element fast enough to keep it from glowing. Those heating elements might retain their bright shiny surfaces after much use.

When a wire element burns out, the ends at the break might be left dangling. An end could contact the grounded metal of the appliance and form a new circuit. Depending on how much resistance was left in the segment of the element, the contact ground fault could allow the appliance to continue to function, to overheat, or to open the protection.

Sheathed elements consist of a resistance wire surrounded by an insulator (e.g., magnesium oxide) and encased in a metal sheath. The sheath is usually made from steel, but many baseboard or other space heaters have sheaths made from aluminum. Melting of an aluminum sheath is more likely to be a result of external fire than of internal heating; however, if melting and heating of the sheath, cooling fans, or adjacent materials show a clear pattern of coming from the element, that is good evidence that the element overheated. The element can be tested for electrical continuity and resistance. A burned-out element might indicate overheating or it might be simply old age. X-rays can assist in diagnosing the internal condition of the element.

A few electrical heaters have failed by ground faulting between the element and the sheath through the insulation, leaving characteristic eruptions of melted metal at various points along the sheath. Although heaters are normally designed so that no combustible materials are easily ignited by the element, the spatter from such arcing might ignite close combustibles if the spatters get through the protective grille.

21.5.8 Lighting. Lighting is used in many appliances to illuminate dials, work areas, or internal cavities. Lights are normally of low wattage and are not likely to be able to ignite anything ordinarily in or on the appliance. Most lighting will be incandescent, but fluorescent lights may be used to illuminate work spaces on the appliance. Fluorescent lights have ballasts (essentially a transformer) that can overheat. However, except for old ones, they have thermal protection and are usually enclosed in the appliance, where they are not likely to ignite anything. Fluorescent lamp tubes do not normally become hot enough to ignite adjacent combustibles, but some incandescent lamps may get hot enough to ignite combustibles that they touch.

21.5.9 Miscellaneous Components. There are miscellaneous devices, such as dimmers and speed controllers, that might be found as components of appliances. Generally, many of these devices are now solid state, fully electronic. Older appliances may contain nonelectronic devices, such as rheostats or wire resistors. Electronic components are usually destroyed by fire unless the fire was brief. In most cases, the remains of dimmers or other electronic devices using printed circuit boards will not be helpful in finding the cause because of their susceptibility to fire damage.

Timers can be built in or can be used as separate devices. They are driven by small clock motors with mechanical actuation of switches. Remains of any timers that were present can

usually be found after a fire, but they may be badly damaged. Small timer motors last a long time and will not overheat to cause a fire. Failure of the timers is usually caused by the gears wearing out or losing teeth. Electronic timers may not leave recognizable remains after being heated by fire.

Thermocouples are used to measure temperature differences. They function by creating a voltage at a junction of dissimilar metals, which is compared to the rest of the circuit or to a reference junction. The temperatures can be read on meters or on digital devices.

A thermopile is a series of thermocouples arranged so that the voltages at the series of junctions add to a large enough voltage to operate an electromagnet. Thermopiles have been used in gas appliances to keep a valve open when the pilot flame is burning but to let the valve close if the pilot flame is out. Newer gas appliances use electric igniters instead of standing pilots.

21.6 Common Residential Appliances. A brief description of the operation and components of common residential appliances is provided to assist the investigator in understanding how these appliances work.

21.6.1 Range or Oven. The heat is provided either by electricity passing through resistance heating coils or by burning natural gas or propane. In the oven, the interior temperature is controlled by a thermostat and a valve or switch on the fuel or power supply. On a gas range, the fuel flow rate and heat intensity is usually controlled with the burner fuel supply valve. An electric range typically utilizes a timing device that controls the cycling time of the burner. This device is manually adjusted so that a high setting results in the longest (possibly continuous) on cycle. Ignition of the fuel gas in a gas range or oven may be by a standing pilot flame or by an electrical device that produces an arc for ignition.

21.6.2 Coffee Makers. The coffee maker design popular for home use consists of a water reservoir, heating tube, carafe, and housing. When started, the heating tube boils the water flowing through it from the reservoir. This boiling forces hot water to the area where the ground coffee is kept in a filter, and the coffee then drips into the carafe. The carafe in many designs sits on a warming plate. The warming plate is usually heated by the same resistance heater that heats the heating tube. The resistance heater is controlled by a thermostat that cycles it off when it reaches the upper limit of the thermostat. The heater will cycle on once it has cooled to a point determined by the thermostat. To prevent overheating by the heater, a thermal cutoff may be employed. If the maximum temperature of the TCO is reached, it is designed to open the heater circuit and prevent further heating. Some coffee maker designs may include multiple TCOs, automatic timing circuits that turn the coffee maker off after a fixed period, or a clock or automatic brew mode that turns the coffee maker on at a preset time. The TCO(s) should be checked to determine whether it has been bypassed.

21.6.3 Toaster. The toaster uses electrical resistance heaters to warm or toast food. It is a relatively simple appliance that utilizes an adjustable sensor to control the on time. By pushing down a lever, the food is lowered on a tray into the toaster, and the heaters are turned on. The sensor is usually a bimetal strip that might sense the temperature in the toaster, but more commonly the bimetal has its own heater and is nearly independent of the temperature in the toaster. At the conclusion of the heating cycle, a mechanical latch partly releases the tray and turns off the bimetal heater. As the bimetal cools, a second latch fully

releases the tray, which then lifts the food. Some newer designs use an electronic timer that controls an electromagnetic latch.

21.6.4 Electric Can Opener. The electric can opener uses an electric motor to turn a can under a cutting wheel to open the can. Generally they will run only when a lever is manually held down. This seats and holds the cutting wheel in place and closes the power switch to the motor. The electric motor may or may not be protected against overheating by a thermal cutoff switch.

21.6.5 Refrigerator. The common refrigerator and freezer utilizes a refrigeration cycle and ventilation system to keep the inside compartment at suitable temperatures. The refrigeration system consists of an evaporator (i.e., heat exchanger in the compartment), a condenser (i.e., heat exchanger outside the compartment), a compressor, a heat exchange medium (typically a fluorocarbon or Freon®), and tubing to connect these components. Warm air from inside the enclosure is used to evaporate the heat exchange medium; the coolant vapor moves to the compressor where it is compressed and condensed back to a liquid in the condenser. When the coolant condenses, it gives off the heat it picked up in the enclosure. As a result, the air around the evaporator is cooled and the air around the condenser is heated. The cool air is circulated within the refrigerator and the hot air dissipates into the room in which the appliance is located. This cooling cycle is controlled by a timing device that regulates the length of the cycles, or it may have a thermostat device that controls the cycle.

The compressor is typically powered by an electric motor that is usually protected with a thermal cutoff. The compressor is usually located in a sealed container, which can prevent an overheated compressor from igniting nearby combustibles because it acts as a heat sink. Additional systems in a refrigerator include lighting, ice maker, and water dispenser, and a fan for the condenser and possibly one for the evaporator.

The refrigerator may also have heating coils in various areas for automatic defrosting and to prevent water condensation on outside surfaces. Automatic defrosters are designed to operate at regular intervals to prevent the accumulation of frost on inside surfaces, especially the freezer.

The antisweat (external condensation) heaters are located under exterior faces, and they operate at regular intervals to prevent condensation. Some models allow this feature to be disabled to conserve power. In both cases, these heaters are typically low-wattage electrical resistance heaters.

21.6.6 Dishwasher. A dishwasher uses a pump to spray and distribute hot water and soap onto the dishes. An electric resistance heater is typically located in the bottom of the unit, where it further heats the water being used. Once the washing and rinsing is complete, the water is drained, and the dishes are dried by the resistance heater, which is exposed to air after the water has drained. Some models allow the electric heater to be disabled during the drying cycle in order to save power. Other devices in the appliance include electrically operated valves and a timer control to regulate the various cycles. The electric pump motor may or may not be thermally protected. Some dishwashers have caused fires by electrical faulting in the push-button controls that then ignited the plastic housing.

21.6.7 Microwave Oven. A microwave oven utilizes a device known as a magnetron to generate and direct the radio waves (i.e., microwaves) into the enclosure. The frequency of these radio waves causes items placed in the oven to heat. To provide for even distribution of these waves, a device is used to scatter them inside the enclosure, and a food tray on the bottom may

be rotated. The microwave oven will also have timing and control circuits, a transformer, and internal lighting. The transformer is used to produce the high voltage required by the magnetron. The magnetron will usually be provided with a thermal cutoff switch. There may be thermal cutoffs above the oven compartment to remove power in case of a fire in the oven.

21.6.8 Portable Space Heater. Portable space heaters for residential use have many designs but are generally divided into two groups: convective or radiative. A convective heater uses a fan to force room air past a hot surface or element. A radiative heater does not have a fan and uses heat transfer by radiation to heat the space. The energy provided to these heaters may be by electricity or by the combustion of solid, liquid, or gaseous fuels. A complete discussion of the many heater designs is not appropriate here, but the investigator should become familiar with the particular design in question. Familiarization can be achieved by reviewing operating manuals and design drawings and by examining an exemplar heater. These heaters employ a variety of control methods and devices. Generally, these devices are present to control the heater, prevent overheating, or shut the heater off if it is upset from its normal position.

21.6.9 Electric Blanket. An electric blanket consists of an electric heating element within a blanket. The controls are typically located separate from the blanket, on the power cord. The control is typically manually adjusted to control the on-off cycle time. In one or more places near the heating elements within the blanket are located thermal cutoffs to prevent overheating of the appliance, and there may be as many as 12 or 15 of these, depending on the appliance. An electric blanket is designed not to overheat when spread out flat. If it is wadded or folded up, heat may accumulate in the blanket and get it hot enough to char and ignite. Normally, the cutoffs prevent overheating.

21.6.10 Window Air Conditioner Unit. A window air conditioner unit is designed to be placed in the window of a residence to cool the room. The unit does this by means of a refrigeration cycle very similar to that used by refrigerators. (See 21.6.5.) Air from the room is circulated through the unit, past the evaporator, which cools the air, and is then discharged to the room. A fan powered by an electric motor does the work of circulating the air. The fan motor is usually protected from overheating by a thermal cutoff. These units have controls for selecting fan speed, cooling capacity, and temperature. These units are powered by a nominal 120 V circuit, or larger units may require nominal 240 V service.

21.6.11 Hair Dryer and Hair Curler. Typical residential hair dryers use a high-speed fan to direct air past an electric resistance heating coil. Controls are typically limited to on or off. Some units may have more than one heater power (wattage) and fan speed settings. One or more resettable thermal cutoff switches are typically provided near the heaters to prevent them from overheating.

Hair curlers or hair curling wands use an electric resistance heater within the wand, around which hair is wrapped to curl it. Some models allow the addition of water to a compartment that can be used to generate steam. Typical controls include an on-off switch and a power setting. Most models include a light to indicate that the unit is operating. Typically these units have one or more thermal cutoffs near the heating element, which may or may not be resettable.

21.6.12 Clothes Iron. A modern clothes iron uses an electrical resistance heater, located near the ironing surface, to heat that surface. Many models require the addition of water, which is used to distribute the heat and to produce steam. The controls on typical irons range from a simple temperature selector and an on-off switch to electronically controlled units that turn themselves off. Irons are designed to heat in both the vertical and horizontal position. Most irons are provided with one or more thermal cut-outs to prevent overheating.

21.6.13 Clothes Dryer. All clothes dryers use electricity to rotate the clothing drum and to circulate air with a blower. Energy for the heat source may be by the combustion of a fuel gas or by electricity. All electric dryers are powered by either a nominal 120 V or a 240 V source. The clothing is dried by spinning it in a drum, through which heated air is circulated. Air is discharged from the dryer via a duct that is typically directed to the exterior of the house. Most dryers have filters to trap lint, which can build up in the dryer. However, if the trap is clogged or not working or if the material being dried gives off a large quantity of lint, this material can accumulate in other areas of the dryer and its vent, which can be a fire hazard. Frictional heating sufficient to cause ignition can result if a piece of clothing or other material becomes trapped between the rotating drum and a stationary part. Fires have been reported in dryers when vegetable oil-soaked rags or plastic materials such as lightweight dry cleaner bags have been placed in the dryer.

Typical dryers have timing controls, humidity sensors, heat source selectors, and intensity selectors to control the operation of the dryer. Thermal cutoffs are provided to prevent overheating of the dryer and components such as the blower motor and heating elements.

21.6.14 Consumer Electronics. Consumer electronics include appliances such as televisions, VCRs, radios, CD players, video cameras, personal computers, and so forth. These devices are similar in their components in that they typically include a power supply, circuit boards with many electronic components attached, and a housing. Some of these appliances, such as televisions and CD players, have components that require high voltage. Additionally, many of these appliances can be operated via remote control. A complete discussion of the many designs of these appliances is not appropriate here, but the investigator should become familiar with the particular design in question. Familiarization can be achieved by reviewing operating manuals and design drawings and by examining an exemplar appliance.

21.6.15 Lighting. Typical residential lighting is either the incandescent or fluorescent type. Incandescent lighting uses a fine metal filament within the bulb, which has been filled with an inert gas such as argon, or the bulb is evacuated and sealed. When an incandescent bulb is working, a major by-product is the generation of heat. Fluorescent lightbulbs use high voltage from a transformer (the ballast) to initiate and maintain an electric discharge through the light tube. The interior of the tube is coated with a material that fluoresces or gives off light when exposed to the electrical discharge energy. The light-generating process in this case generates little heat as a by-product, but the ballast typically will give off heat. Thermally protected fluorescent light ballasts have a resettable thermal switch to prevent the ballast from overheating. (See 21.5.5.)

Chapter 22 Motor Vehicle Fires

22.1 Introduction. This chapter deals with factors related to the investigation of fires involving motor vehicles. Included in this discussion are automobiles, trucks, heavy equipment, and recreational vehicles (motor homes). While vehicles that travel by air, on water, or on rails are not covered, there are many factors relating to incident scene documentation, fuels, ignition sources, and ignition scenarios that may apply.

The burn or damage patterns remaining on the body panels and in the interior of the vehicle are often used to locate the point(s) of origin and for cause determination.

It was once felt that rapid-fire growth and extensive damage was indicative of an incendiary fire. However, the type and quantity of combustible materials found in automobiles today, when burned, can produce this degree of damage without the intentional addition of another fuel, such as gasoline. In the case of a total burnout, one cannot normally conclude whether or not the fire was incendiary on the basis of observations of the vehicle alone. The use of fire patterns or degree of fire damage to determine a point of origin or cause should be used with caution. The interpretations drawn from these patterns should be verified by witness evidence, laboratory analysis, service records indicating mechanical or electrical faults, factory recall notices, or complaints and service bulletins that can be obtained from the National Highway Transportation Safety Administration (NHTSA), or the Center for Auto Safety. The investigator should also be familiar with the composition of the vehicle, and its normal operation. (*See Chapter 4.*)

The relatively small compartment sizes of vehicles may result in more rapid fire growth, given the same fuel and ignition source scenario, when compared to the larger compartments normally found in a structure fire. However, the principles of fire dynamics are the same in a vehicle as in a structure and, therefore, the investigative methodology should be the same. (*See Chapters 2 and 3.*)

22.2 Vehicle Investigation Safety. The completion of a thorough investigation of a burned vehicle may pose a variety of safety-related concerns that are different from those that may normally be found in a structure fire.

When completing an inspection of the vehicle undercarriage, the investigator should take care to prevent the vehicle from moving and causing investigator injury. The use of hydraulic lifts designed to hold the vehicle weight, jacks, or other lifting devices used in conjunction with blocking or stands will assist in preventing sudden movement or to prevent the vehicle from falling on the investigator.

Undeployed airbags (supplemental restraint systems) also pose a serious potential safety concern for fire investigators. Sodium azide, the expelling agent for the airbag, is a hazardous material, and contact or inhalation can constitute a potential health hazard for the investigator. Some vehicles are also equipped with an additional airbag and reactive occupant restraint systems. The investigator will need to identify the systems that are present, the operational condition of those systems, and, if necessary, should render those systems safe prior to disturbing the passenger compartment, to prevent accidental operation.

Vehicle fire inspections may present many other situations that pose safety hazards to the investigator. These can include fuel leaks or remaining fuel in fuel tanks posing a fire hazard; expelled lubricants, which may pose slip and fall hazards; electrical energy stored in the battery; or broken glass, which may pose puncture or cut hazards.

22.3 Fuels in Vehicle Fires. A wide variety of materials and substances may serve as the first materials ignited in motor

vehicle fires. These include engine fuels; transmission, power steering, and brake fluids; coolants; lubricants; and the vehicle interior materials or cargo. Once a fire is started, any of these materials may contribute as a secondary fuel, affecting the fire growth rate and the ultimate damage sustained.

22.3.1* Liquid Fuels. Liquid fuels are often associated with vehicle fires, as they are almost universally present. These fuels may come in contact with an ignition source as the result of a malfunction of one of the vehicle systems, an accident involving fuel release, or an incendiary act. Table 22.3.1 provides some of the properties of commonly encountered liquid fuels.

Whether a given fuel can actually be ignited depends on the properties of the fuel, its physical state, the nature of the ignition source, and other variables. Flash point is of little or no significance when a fuel is released in spray form. Ignition on hot external surfaces may require temperatures of 200°C (360°F) above published ignition temperatures. See Chapter 3 for additional information on the process of ignition.

22.3.2 Gaseous Fuels. Alternate motor fuels, notably propane and compressed natural gas, are finding increasing use in fleets of automobiles and in trucks as well as in some privately owned vehicles. The use of these fuels is expected to increase in the future, along with the introduction of hydrogen. Propane is also found aboard the majority of recreational vehicles as a cooking, heating, and refrigeration fuel. Hydrogen and oxygen can be found in association with wet-cell lead acid batteries and may be released during charging or as a consequence of a collision. Larger quantities of these gases may be found in larger vehicles or as cargo. Many gases are stored as a liquid under pressure, and become gaseous when released. Some properties of gaseous fuels are given in Table 22.3.2.

22.3.3 Solid Fuels. Solid fuels are less common than liquids and gases as the first materials ignited in motor vehicle fires, except in scenarios where overloaded wiring or smoking materials are possible ignition sources, or where the vehicle is subjected to an exposure fire. Frictional heating may also be an ignition source involving drive belts, bearings, or tires. Given even a small initial fire, solid fuels may contribute significantly to the speed of the fire growth and may spread the extent of damage. Plastic materials can burn with heat release rates similar to those of ignitable hydrocarbon liquids. Plastics often sag or drop flaming pieces. Some metals can be ignited if they are in the proper form. Most metals need to be melted or powdered to burn. Metals such as aluminum and magnesium and their alloys can also burn in vehicle fires, adding additional fuel.

Investigators should not interpret the presence of melted metals to be an indicator of the use of an ignitable liquid as an accelerant, in the belief that only an ignitable liquid can produce sufficiently high temperatures. Common combustibles and ignitable liquids produce essentially the same flame temperature. Melting temperatures given in handbooks and in this guide are for the pure metal, unless otherwise stated. In many cases, alloys are used rather than the pure metal. The melting temperature of an alloy is generally lower than that of its constituents. The actual composition of a metal part and its melting temperature should be determined before any conclusions are drawn from the fact that it has melted. Accidental alloying may occur during a fire. For instance, zinc may drip onto a copper wire or tube and form a brass alloy, which melts at a lower temperature than copper. Likewise, molten aluminum can drip onto steel sheet metal, which can cause the appearance of melting of the sheet steel. Some properties and uses of solid fuels are given in Table 22.3.3.

Table 22.3.1 Properties of Ignitable Liquids in Motor Vehicle Fires

Liquid	Flash Point		Ignition Temperature		Flammability Range (%)		Boiling Point		Vapor Density (Air = 1)
	°F	°C	°F	°C	Lower	Upper	°F	°C	
Brake fluid ^a	240–355	115–179							
Brake fluid ^b	298	148					485	252	
Ethylene glycol (100%) ^c	232	111	775	413	3.3	—	387	197	
Ethylene glycol (90%) ^c	270	132							
Diesel #2D ^d	126–204	52–96	494	257	—	—			
Kerosene #1 fuel oil ^d	100–162	38–72	410	210	0.7	5.0	304–574	151–301	
Gasoline — 100 octane ^d	–36	–38	853	456	1.4	7.6	100–400	38–204	3–4
Methanol ^d	52	11	867	464	7.8	86.0	147	64	1.1
Motor oil ^e	410–495	210–257	500–700	260–371					
Trans fluid ^e	350	177							
Trans fluid ^b Dextron IIE	361–379	183–193	410–417	210–214					
Dextron II	367	186	414	212					
Type F (Ford)	347	175							
Power steering fluid ^e	350	177							

Note: The data provided in this table are for generic or typical products when tested in a specific way. The test methods may not be the same for each material. The information in this table is from various sources within published literature.

^a NFPA SPP 51, *Flash Point Index of Trade Name Liquids*, p. 182.

^b UNOCAL Lub Oils and Greases Div.

^c Flick, Noyes Data Corp., *Industrial Solvents Handbook*, p. 416.

^d NFPA *Fire Protection Guide to Hazardous Materials*.

^e Severy, Blaisdell, and Kerkhoff, *Automobile Collision Fires*.

Table 22.3.2 Gaseous Fuels in Motor Vehicles

Gas	Ignition Temperature		Boiling Point		Flammability Range %		Vapor Density (Air = 1)
	°F	°C	°F	°C	Lower	Upper	
Hydrogen	932	500	–422	–252	4.0	75.0	0.1
Natural gas (methane)	999	537	–259	–162	5.0	15.0	0.6
Propane gas	842	450	–44	–42	2.1	9.5	1.6

Note: The data provided in this table are for generic or typical products and may not represent the values for a specific product. When possible, values specific to the product involved should be obtained from a material safety data sheet or by test.

Source: NFPA *Fire Protection Guide to Hazardous Materials*.

Table 22.3.3 Solid Fuels in Motor Vehicle Fires

Material	Ignition Temperature		Melting Point		Comments
	°F	°C	°F	°C	
Acrylic fibers	1040	560 ^b	122	50 ^b	
Aluminum (pure)	1832	1000 ^{e*}	1220	660 ^{e*}	
ABS	871	466 ^b	230-257	110-125 ^c	Body panels — may be completely consumed
Fiberglass (polyester resin)	1040	560 ^b	802-932	428-500 ^c	Resin burns but not glass body panels
Magnesium (pure)	1153	623 ^{e*}	1202	650 ^{e*}	
Nylon ^a	790	421 ^b	349-509	176-265 ^c	Trim, window gears, timing gears
Polyethylene	910	488 ^f	251-275	122-135 ^g	Wiring insulation
Polystyrene	1063	573 ^f	248-320	120-160 ^g	Insulation, padding, trim
Polyurethane — foam	852-1074	456-579 ^f			Seats, arm rests, padding
Polyurethane — rigid	590	310 ^b	248-320	120-160 ^c	Trim
Vinyl (PVC)	945	507 ^f	167-221	75-105 ^g	Wire insulation, upholstery

Note: The data provided in this table are for generic or typical products and may not represent the values for a specific product. When possible, values specific to the product involved should be obtained from the manufacturer or by test.

*Pure metal

^a Lide (ed.), *Handbook of Chemistry and Physics*.

^b Hilado, *Flammability Handbook for Plastics*.

^c *Guide to Plastics*.

^d Baumeister, Avallone, and Baumeister, *Marks' Standard Handbook for Mechanical Engineers*.

^e NFPA *Fire Protection Handbook*, Table 3.13A (17th edition).

^f NFPA *Fire Protection Handbook*, Table A.6 (17th edition).

^g *Plastics Handbook*.

22.4 Ignition Sources. In most instances, the sources of ignition energy in motor vehicle fires are the same as those associated with structural fires, arcs, overloaded wiring, open flames, and smoking materials. There are, however, some unique sources that should be considered, such as the hot surfaces of the catalytic converter, the turbocharger, and the manifold. Because some of these ignition sources may be difficult to identify following a fire, the descriptions in 22.4.1 through 22.4.5 are provided to assist in their recognition.

22.4.1 Open Flames. The most common open flame in a carbureted vehicle is caused by a backfire through the carburetor. Propagation will rarely occur if the air cleaner is properly in place. Most vehicles today, however, use a fuel injection system that eliminates the need for a carburetor. Lighted matches in ashtrays may ignite debris in the ashtray, resulting in a fire that exposes combustible plastic dash or seat materials. In recreational vehicles, appliance pilot flames or operating burners and ovens are open-flame ignition sources.

22.4.2 Electrical Sources. When the engine is not running, the primary source of electrical power in a motor vehicle is the battery. In most cases, without a battery, there is no source of electrical energy to start a fire. A limited number of components remain electrically connected to the battery, even though the ignition switch is off and the engine is off. These components, such as an alternator or ignition switch, can fail hours after the vehicle was last used. The investigator should determine if the vehicle was running at the time of the fire. A vehicle

that is running has many more potential sources of ignition. Protection of electrical circuits in motor vehicles is provided by fuses, circuit breakers, and fusible links. As with structures, any of these safety devices can be altered, bypassed, or fail. The installation of additional equipment can affect the way a safety device will operate. Unlike the electrical systems of most structures, motor vehicle electrical systems are often direct current (dc) systems. The frame, body panels, and engine are electrically connected to form the ground or negative side of the system. The negative side of the battery is connected to the frame or engine block or both. The positive side of the battery supplies current to the fuse panel and to all electrical accessories. This means that any electrical device may appear to have only one wire physically connected. It also means that the ground path may not be the most obvious one. Any time an energized positive wire, terminal end, or component touches a grounded surface, a completed circuit can result.

Recreational vehicles may have both onboard batteries and wiring like a motor vehicle and alternating current (ac) wiring and fixtures like a structure. They may also be equipped with a converter that changes the ac (household) current into dc power for lighting, and so forth. They may further be equipped with an onboard generator to provide ac current when an outside source is not available.

22.4.2.1 Overloaded Wiring. Unintended high-resistance faults in wiring can raise the conductor temperature to the ignition point of the insulation, particularly in bundled cables such as the

wiring harnesses or the accessory wiring under the dash, where the heat generated is not readily dissipated. This can occur without activating the circuit protection. Faults and mechanical failures of high-current devices such as power seat or window motors can also result in ignition of insulation, carpet materials, or combustible debris that may accumulate under seats. Some vehicles, for instance, are equipped with heated seating that uses self-regulating wires. A fault can cause a shorter-than-intended heating path, resulting in overheating. The addition of accessories may overload factory wiring. This overload is commonly found with the addition of aftermarket stereo equipment or alarm systems. An installer may place equipment of higher electrical demand in a vehicle, along with a higher capacity fuse. Some installations of aftermarket equipment do not include any safety device. Pre-fire history of electrical malfunction may be a clue.

22.4.2.2 Electrical Arcing. Electrical arcing can result when the conductor's insulation becomes worn, brittle, cracked, or otherwise damaged, allowing it to contact a grounded surface. A connector can break or come loose. This can be the result of fluid leakage deteriorating the insulation or the result of an impact. In postcrash situations, arcs can be generated through the crushing or cutting of wires, particularly battery and starter cables, which are not electrically protected and are designed to carry high currents. The large amount of energy available in a battery can be enough to ignite materials such as engine oil accumulations, some plastic materials, and electric insulation. Significant arcing can also occur along with the crushing of the battery or batteries.

22.4.2.3* Lamp Filaments of Broken Bulbs. Lamp filaments of broken bulbs are also a source of ignition energy, especially for gases, vapors, or liquid fuels in a spray or mist form. Normally operating head-lamp filaments have temperatures on the order of 2550°F (1400°C). However, most filaments operate in a vacuum or inert atmosphere. When the filament is exposed to ambient air, it will typically operate for only a few seconds, then burn open. Once the filament opens, the source of ignition is gone.

22.4.2.4 External Electrical Sources Used in Vehicles. While most electrical sources in vehicles are self-contained, there are situations where electrical power is provided from commercial facilities. Examples of these sources are electrical hook-ups used in recreational vehicles and trailers, or electric heaters for engines and vehicle interiors. Battery chargers may also provide an external source of electricity. Many vehicles used in colder climates, especially those with diesel engines, have an electric heater to assist with starting. This heater can be a permanent piece of equipment on the vehicle, with a secondary power cord. Inspection for electrical power cords should be made when applicable, since an overload of the cord or a failure of the appliance could be the cause of the fire. Improper application of external electricity can damage vehicle components, resulting in failure, and possibly in fire. Where recreational vehicles are connected to commercial power, the branch circuit wiring should be inspected for indications that it was a possible ignition source.

22.4.3* Hot Surfaces. Exhaust manifolds and components can generate sufficiently high temperatures to ignite diesel spray and to vaporize gasoline. Automatic transmission fluid, particularly if heated due to an overloaded transmission, can ignite on a hot manifold. Engine oil and certain brake fluids (DOT 3 and 4) dropping on a hot manifold can also ignite. These fluids may ignite after the vehicle is shut off. This ignition is due to the loss of airflow through the engine compartment, which disperses these vapors and cools hot engine surfaces.

When the engine is shut off, the airflow ceases, and manifold temperatures can rise. This may be sufficient to ignite the fluid vapors. The internal components of a catalytic converter have operating temperatures of approximately 1300°F (700°C) under normal operation and can be much higher if unburned fuel is introduced due to a fuel or ignition system malfunction. External temperatures of these converters can reach temperatures of 600°F (315°C) under normal operation and can become higher where ventilation or air circulation is restricted. In most vehicles, the pipe surface just upstream of the catalytic converter will operate hotter than the converter itself.

Typically, gasoline will not be ignited by a hot surface, but requires an arc, spark, or open flame for ignition. While ignition of gasoline vapor by a hot surface is difficult to reproduce, such ignitions should not be dismissed out of hand. As a rule of thumb, ignition by a hot surface in the open air should not be assumed unless the surface temperature is about 200°C (360°F) above the accepted minimum ignition temperature.

22.4.4* Mechanical Sparks. Metal-to-metal contact (steel, iron, or magnesium) or metal-to-pavement contact can create sparks with enough energy to ignite gases, vapors, or liquids in an atomized state. Metal-to-metal contact can occur at drive pulleys, drive shafts, or bearings, for example. Metal-to-pavement contact typically involves a broken drive shaft, exhaust system, or wheel rim after the loss of a tire. All metal-to-metal or metal-to-pavement sparking requires that the vehicle be running or in motion. Sparks generated at speeds as low as 5 mph (8 km/h) have been determined to reach temperatures of 1470°F (800°C) (orange sparks). Higher speeds have produced white sparks in the 2190°F (1200°C) range. Aluminum-to-pavement sparks are not an ignition source. Although sparks may have sufficient energy to ignite gases, vapors, or atomized liquids due to the small particle size of most sparks, their energy is quickly dissipated, and they usually are not a competent ignition source. They generally will not ignite solids. Sparks from tools striking metals seldom cause ignition.

22.4.5 Smoking Materials. Modern upholstery fabrics and materials, by their chemical nature, are generally difficult to ignite with a cigarette. Ignition may occur if a lighted cigarette is buried in paper, tissues, or other debris, or if the seat material comes into contact with open flame. Urethane foam seating burns readily, once ignited with a flame, and adds substantially to the intensity of a vehicle fire.

22.5 System Identification and Function. Each system of a motor vehicle has a specific function. Not all motor vehicles have the same systems; however, many systems operate in a similar manner. System familiarity is essential to the proper investigation of a motor vehicle fire. If the investigator does not know how a system operates, he or she will not be able to determine if a system malfunctioned or has been altered, or whether such malfunction or alteration could be responsible for the fire. Almost every motor vehicle has some form of repair publication. Most of these repair manuals explain the systems unique to that particular vehicle. Many publications also have troubleshooting guides to diagnose potential problems. These publications can be found at most auto parts stores, and most public libraries have at least generic repair manuals.

22.5.1 Fuel Systems. There are two basic fuel systems used in gasoline powered motor vehicles: the vacuum/low-pressure carbureted system, and the high-pressure, fuel-injected system. Both systems use a fuel storage tank, tubing, and fuel pump to deliver fuel to the engine. Once the fuel is delivered to the engine, it is atomized, compressed, and burned.

22.5.1.1 Vacuum/Low-Pressure Carbureted Systems. In the vacuum/low-pressure carbureted system, the fuel is typically drawn from the fuel storage tank by a mechanical pump attached to the engine. This pump operates only when the engine is rotating. The fuel is then pumped under approximately 3 psi to 5 psi (20 kPa to 35 kPa) to the carburetor fuel bowl. The fuel flows from the bowl into the venturi, where it is mixed with air in a ratio of approximately 15 to 1. The fuel-air mix is then drawn into the combustion chamber through the intake valve. The piston compresses the mixture and a spark ignites it. Potential problems with this system typically occur on the pressure side. If a leak develops on the vacuum side, air is drawn into the system, and the vehicle generally will not run. Leaks on the pressure side, however, may range from a fine mist to a heavy stream. Leaks can occur in a fuel line or at the carburetor and generally occur within the confines of the engine compartment. If an ignition source is available, a fire could result. If a fuel line is compromised by a fire from another source, the fuel may contribute significantly to fire growth, and the result may be a fuel system that appears to be the cause of the fire. Note that some vehicles, originally sold with a mechanical pump, may have had the mechanical pump replaced by an electric pump. If the mechanical pump does not appear to be connected to a fuel line, an electric pump may be in use.

22.5.1.2* High-Pressure Fuel-Injected Systems. In the high-pressure fuel-injected system, the fuel is typically pumped from the fuel storage tank under pressures of 35 psi to 70 psi (240 kPa to 480 kPa). This is accomplished with an electric pump in or near the fuel storage tank. This pump is typically energized any time the ignition key is in the run position. Most late model vehicles have electric fuel pumps that are integrated with the engine's computer. This computer will shut the pump off if the engine is not running. Some vehicles are also equipped with an inertia switch. This switch will shut the fuel pump down in case of an impact. The fuel is pumped to either a single venturi-mounted fuel injector or a fuel rail assembly on the engine. The single venturi-mounted fuel injector is typically located inside a device that resembles a carburetor. Fuel is injected (atomized) in a much more controlled manner than in a carburetor, increasing fuel economy and power. Additionally, by providing a stable fuel-air mixture, this injector reduces pollution. The fuel rail assembly is a tube located on top of the engine to supply constant fuel pressure and flow to cylinder-mounted fuel injectors. Both of these types of high-pressure systems also include a fuel return system. The fuel return system carries the unused fuel back to the fuel storage tank at nearly the same operating pressure as the fuel supply. Potential problems with this system include leaks at fittings. When a leak develops, the system pressure can propel a stream of fuel several feet. If the leak develops on the supply side of the system, operational problems should be noticed by the operator. These can result in poor performance of the vehicle, including starting difficulties, erratic operation, and stalling. A more serious situation is a leak on the return side of the system. A leak here may go undetected. This fuel is pressurized nearly as much as the supply side; however, operational difficulties may not be evident. Even vehicles that are not running typically have residual pressure in the fuel system. Many vehicles are being equipped with flow detection equipment that monitors fuel usage and fuel return. If this system detects an imbalance, the system will shut down. If a fire in a parked vehicle compromises the fuel line, there will usually be little leakage, if the line enters the top of the tank. Lines that enter the bottom of the storage tank may siphon or feed by gravity many gallons of fuel into a fire, once they have been compromised. Even if the

compromise in the fuel line is above the level of fuel in the tank, fuel may be released due to either residual pressure in the tank or pressure resulting from exposure to the fire.

22.5.1.3 Diesel Fuel Systems. Diesel-powered vehicles typically use a combination of pumps to deliver the fuel from the fuel storage tank to the engine. Sometimes, electric lift pumps are used in or near the fuel storage tank, or engine-mounted mechanical pumps are used. These lift pumps are typically high-volume, low-pressure devices. They supply fuel to the engine-mounted fuel injector pump. The fuel injector pump meters and delivers the fuel into each cylinder at the appropriate time for combustion. Combustion air is brought in through natural aspiration or under pressure from a turbocharger. Diesel fuel delivery systems are typically very robust. Leaks typically develop at fittings loosened by the vibration of the engine. Diesel fuel, unlike gasoline, will readily ignite on contact with a hot surface. "Runaway" diesel engines are a rare occurrence, but they do happen occasionally. They occur when airborne combustible vapors are taken into the intake system via the engine air supply. This has the same effect as continually depressing the accelerator, and under extreme conditions, the engine will literally tear itself apart and explode into a fireball. The only sure way to stop an engine under these circumstances is to shut off the air supply.

22.5.1.4 Natural and Propane Fuel Systems. As with engine fuels, these gases are stored as liquids in pressurized containers and typically flow to a regulator at the engine. This system operates under high pressures. Most natural or propane-fueled motor vehicles still utilize a carbureted system to mix the fuel and combustion air. Leaks found after the fire, in the course of a system pressure check, may not indicate a pre-fire leak. This is due, in part, to differing coefficients of expansion between the fittings and the piping materials. Potential problems with this system are inherent in the nature of the fuel. If a leak develops, the escaping gas can travel great distances and can be ignited by a remote source. If this occurs, the fire can flash back to the source. Explosions may occur. It is not uncommon for natural or propane fuel storage tanks to rupture during a fire. This rupture is due to internal pressure, which cannot be relieved quickly enough, building during the fire. As appliance fuels, typically found in recreational vehicles for cooking, heating, and refrigeration appliances, these gases are stored as liquids in pressurized containers and flow immediately into a pressure regulator for distribution to the appliances. The danger from a leak is not as severe as in an engine fuel system, but it can be as catastrophic. The investigation of appliance fuel fires requires many of the same techniques as that of a structure investigation. More information about natural gas systems can be found in NFPA 54, *National Fuel Gas Code*. More information about propane gas systems can be found in NFPA 58, *Liquefied Petroleum Gas Code*.

22.5.1.5 Turbochargers. Turbocharging is the utilization of a turbine to add to the power output of an engine by increasing the amount of the air being forced into the cylinder. The turbine used to drive the compressor turns at up to 100,000 rpm. The turbocharger uses exhaust gases for propulsion, and in many cases, the turbocharger is the hottest point on an engine. The heat created can ignite fuels or other ignitable materials, should they come in contact with the unit. Both gasoline- and diesel-fueled engines can be turbocharged. An oil leak from a turbocharger can increase its operating temperature and can be the first fuel ignited in a fire.

22.5.2 Emission Control System. Most motor vehicles are equipped with some form of emission control. This system controls exhaust emissions and collects gasoline vapors. This system typically regulates fuel input, timing adjustments, and exhaust gas recirculation (EGR). The major components of this system are located in the engine compartment, and consist of the EGR valve, a charcoal canister, a variety of rubber vacuum hoses, and sensors that interface with the onboard computer. The EGR valve recirculates a portion of the exhaust gases, so that the engine will warm up more quickly without putting fuel-rich vapors into the atmosphere. The charcoal canister collects excess fuel vapors. These vapors are drawn into the engine and burned when the engine is started. A potential problem is vapor leakage from the charcoal canister or vapor hoses. These vapors can travel throughout the engine compartment, and, if an ignition source is present, they can ignite in the same manner as the gases previously discussed. Overfilling of the fuel tank can force liquid into the charcoal canister, causing flooding. Improperly installed additional fuel tanks can overwhelm the vapor recovery system. The EGR valve can stick, causing fuel-rich exhaust gases to be recirculated into the engine. This can cause rough idling, stalling, backfires, and overheating of the catalytic converter.

22.5.2.1 Exhaust System. The exhaust system does more than carry the exhaust gases from the engine. It also serves as a part of the emission control system. The exhaust manifold is bolted directly to the engine. It is the collector for the exhaust gases coming from each cylinder. This manifold is generally located below the valve cover. A leak in the valve cover or gasket may allow engine oil to contact the manifold, which may result in ignition. (See 22.4.3.) In the header pipe (the first section of pipe from the engine), there is usually an oxygen sensor. This sensor detects the oxygen content in the exhaust stream and sends a signal to the onboard computer to make fuel delivery and timing adjustments. The next device downstream in the exhaust system is the catalytic converter. The incoming exhaust pipe, approximately 3 in. to 4 in. in front of the converter, is typically the hottest part of the exhaust system. Temperatures of 650°F (343°C) have been measured during normal operation. If the engine is misfiring or running rich, these temperatures can increase significantly. The remainder of the exhaust system is comprised of the muffler and piping. A potential danger in a normally operating motor vehicle is contact with combustible items, such as tall grass or debris, with exhaust and catalytic converter surfaces. A malfunction in the engine can cause the catalytic converter to run hot enough to ignite undercoating and interior carpeting.

22.5.3 Motor Vehicle Electrical Systems. The 12-volt negative ground dc system has a storage battery as its primary energy source. The battery is connected to both the positive side and negative sides of the electrical system. If either of the battery leads are disconnected, no energy can flow. The starter motor vehicle draws energy from the battery, and after the engine starts, the alternator takes over, providing whatever energy is required. The amount of energy capable of being carried by any conductor can be estimated by the relative size of that conductor. The bigger the conductor, the more energy it can carry. Typically, the largest conductors are routed from the battery to the starter and from the battery to the alternator. These conductors rarely have any over-current protection. Arcing is commonly found on one or more of these conductors after a fire.

In addition to providing electrical energy, the battery can also be a source of fuel in the form of hydrogen gas. Hydrogen can be released during charging operations or as the result of a direct short of an unfused wire, such as the starter cable. Small

amounts of hydrogen and oxygen are also present inside sealed (no maintenance) batteries and can be released due to mechanical damage during a collision. Hydrogen gas has a very wide explosive range and is easily ignited by low energy sources. However, it is unusual for a hot surface to cause hydrogen ignition.

22.5.3.1 Twelve-Volt Electrical Systems. Energy distribution throughout the vehicle is accomplished by connecting the positive 12 volt (+12 V) to a buss bar. This buss bar has fuses or circuit breakers attached, which protect the downstream circuits from overcurrent. A major difference between vehicles and structures is that the entire frame, body, and engine may be used as the ground path. This means that during an inspection, only one conductor may be found connected to a device. This also means that if an energized conductor should chafe or rub on a frame, body, or engine surface, it could complete a circuit. In most cases, this will simply cause the overcurrent protection device to operate and de-energize that circuit. If someone then replaces the fuse with a larger fuse, the problem may seem to be solved. The larger fuse can allow an overloading of the conductors and circuits, which may result in a fire. Only a few circuits have +12 V potential when the engine is not running and the ignition key is off. These are usually the circuit from the battery to the starter, the circuit from the battery to the alternator, and the circuit from the battery to the ignition switch, with a downstream leg to certain accessories such as the clock and cigarette lighter. Circuits supplying aftermarket accessories connected directly to the battery (with or without overcurrent protection) may also be energized when the engine is not running. One method of determining if the vehicle was running at the time of the fire, assuming that the fuses survived the fire, is to examine the engine control fuses. In general, if none of the engine control fuses have opened, the vehicle was not running. Wiring diagrams will typically show conductor insulation color, device location, and function. Many electrical components have the potential to malfunction and overheat. Many of these components also have a ready fuel source in their construction. Most motor vehicle conductors are composed of stranded wiring, which becomes very brittle on heating. Therefore, the wiring should be carefully documented before any substantial movement of the wiring takes place.

22.5.3.2 Other Electrical Systems. Electrical systems in older cars may be only +6 volts. Some older vehicles also have positive ground systems. It is rare that a fire investigator will encounter one of these systems. Larger vehicles may have +24 volt systems. These systems are found in larger trucks, buses, and heavy equipment. Alternate electrical systems are found in recreational vehicles. These systems have a combination of +12 volt dc and 120 volt ac. Many recreational vehicles have converters that change the 120 volt ac to 12 volt dc. These vehicles may also have power inverters which will convert 12 V dc to 120 V ac. RVs may also be equipped with onboard generators that produce 120 volts ac. These generators should be inspected as potential fire causes, since they have most of the same properties as the vehicle itself, that is, fuel supply, ignition system, exhaust system, and so forth.

22.5.4 Mechanical Power Systems. Motor vehicles are usually powered by an internal combustion engine that may run on a variety of fuels. An internal combustion engine is a complex machine with many components working in synchronization. To maintain proper function, all of these parts must remain securely attached, and many require lubrication or cooling. Mechanical failure of the engine can result in components, parts, or pieces being propelled at high speeds away from the engine. Pistons and connecting rods have been known to break through the side of an engine block and damage other components outside the

engine. Oil and crankcase vapors can escape through a hole created by such a failure and ignite on a hot surface. Mechanical failure can also result in the failure of fuel lines. A piece of piston cutting through the fuel line can certainly lead to a fire. Most engines will not operate after a catastrophic mechanical failure or will operate only with seriously diminished performance.

22.5.4.1 Lubrication Systems. Most engines use hydrocarbon oil for lubrication. Oil collects in a pan at the bottom of the engine and is distributed by a mechanical pump. The oil returns to the pan by gravity flow. Most oil pumps operate at 35 psi to 60 psi (240 kPa to 415 kPa). Oil can leak at the many joints or mating surfaces in the engine. Leaks around the pan gasket, for instance, can allow oil to be blown onto the hot exhaust, or oil leaking from a valve cover gasket can flow down onto a hot manifold. Oil leaks may result in fires after the vehicle is turned off (see 22.4.3). Lack of oil in the engine can cause the failure of internal components. These failures can lead to catastrophic mechanical failure, which may, in turn, cause a fire.

22.5.4.2 Liquid Cooling Systems. Engine cooling is accomplished with liquid or air. Liquid-cooled motor vehicles use a closed system consisting of passageways through the engine block, a water pump, hoses, thermostat, and a radiator. As the engine reaches its normal operating temperature, the coolant in the engine also warms. This coolant is circulated through the system by the water pump. When the coolant reaches a pre-set temperature [typically in the range of 180°F to 195°F (80°C to 90°C)], the thermostat opens, allowing the coolant to flow to the radiator. The radiator is a heat exchanger, composed of a series of small tubes, connected between two tanks. A fan is used to provide airflow at low speeds or when the vehicle is stopped. Airflow around the tubes reduces coolant temperature before it is sent back to the engine. A normal cooling system will operate at approximately 16 psi (110 kPa). Most cooling systems are designed to use a mixture of 50 percent ethylene glycol (antifreeze) and 50 percent water. In colder climates, higher percentages of antifreeze are sometimes used.

22.5.4.3 Air-cooled Systems. Air-cooled engines use a fan and ductwork to move air around the engine. These fans are typically belt driven. Engine overheating can occur if the belt breaks. Catastrophic engine failure may result.

22.5.5 Mechanical Power Distribution. Mechanical power produced by the engine must be delivered to the drive wheels. This is accomplished through a transmission. The transmission can consist of mechanical gearing or hydraulically driven gearing. The moving parts within the transmissions require lubrication.

22.5.5.1 Mechanically Geared Transmissions. Mechanically geared transmissions receive engine power through the clutch assembly. The clutch assembly is located between the engine and transmission and consists of a pressure plate bolted to the engine flywheel and a clutch disc on the transmission front shaft. The selection of drive gears is mechanically performed by rods and levers. The gears in the transmission are lubricated in an oil bath. The oil can be as heavy as 120 or 130 weight gear oil, or as light as automatic transmission fluid. Mechanical failures can be as catastrophic as those in the engine. Leaks of transmission lubricant may occur in the area of the exhaust system. Transmission fluid can typically be added only from under the vehicle, directly through openings in the side of the transmission. Overfilling of a manually geared transmission is rare.

22.5.5.2 Hydraulically Geared Transmission. Commonly referred to as automatic transmissions, these devices receive

engine power through a torque converter. A torque converter allows the engine to run at idle without the vehicle moving. This is accomplished by vanes in the torque converter allowing a small quantity of transmission fluid to flow around the vanes. As engine speed increases, the fluid can no longer flow around the vanes and power is transferred to the transmission. Gear selection is performed by the transmission, depending on factors such as engine speed and load demands. The fluid used in automatic transmissions requires cooling. This is typically accomplished by routing the fluid through a cooler in the engine radiator. Fluid can be added by opening the engine compartment, removing the transmission fluid level indicator (dipstick), and pouring fluid down the tube. Overfilling of the transmission can easily occur. Most transmission level indicators specify that the transmission must be idling at normal operating temperatures before the fluid level is checked. Leaks from the pan gasket may occur in the area of the exhaust system. Overfilling can cause fluid to be expelled from the dipstick tube, which is frequently over the exhaust manifold. Fluid expulsion can also result from the transmission operating under heavy load. This can also occur if the wrong type of fluid is added to the transmission.

22.5.6 Accessories to the Mechanical Power System. Air-conditioning compressors, power steering pumps, air pumps, and vacuum pumps are all mechanical devices that may be attached to the engine. All of these devices have their own potential to malfunction. If a malfunction is suspected in one of these devices, an appropriate reference manual should be consulted.

22.5.7 Hydraulic Braking System. The hydraulic braking system is activated by a foot pedal connected to a master cylinder. This master cylinder is connected with tubing to the wheel or slave cylinders. Pressing the brake pedal produces higher pressure in the braking system, which is transmitted to the slave cylinders. This brings the brake linings (shoes and pads) in contact with the brake drums or rotors, creating friction, which stops the vehicle. Brake systems work under high pressures and even a small leak can produce a spray that can be ignited if it contacts an ignition source.

22.5.8 Windshield Washer Systems. Washer fluid is typically high in alcohol content. Windshield washer solvent, if sprayed on a hot surface, can form a vapor that may become ignited. The condition of the windshield washer fluid reservoir(s) should be documented, noting crushing or rupture. The windshield washer solvent reservoir is usually a plastic material and may be consumed in a fire. If this is the case, note whether body parts have penetrated the space that would have been occupied by the reservoir. Some systems use heated nozzles to keep the washer fluid from freezing. A malfunction in the heater may cause a fire. Solutions sufficiently diluted by water will not ignite.

22.6 Body Systems. Many body panels of modern motor vehicles are made of plastic, polymers, or fiberglass materials and will burn during a fire. These materials by themselves do not pose a significant fire hazard; however, after a fire begins, they may significantly add to the fuel load. Often the entire cab of a tractor will be consumed, or door and hood panels will be gone. The inside panels of the front fenders in many cars are plastic; when they burn through, additional ventilation will be available for engine compartment fires. It should be noted that aluminum, magnesium, and their alloys are being used in panels in some vehicles. These panels will burn, often with great intensity. The partition between the engine compartment and the passenger compartment is commonly referred

to as either the *fire wall*, *cowling*, or *bulkhead*. In modern motor vehicles, this partition may have numerous penetrations, some associated with the heating and air-conditioning system ducts. The ducts are usually made of reinforced plastic and can burn, resulting in a path for fire spread into the passenger compartment. Fire can also spread by conduction through the metal partition to combustibles under the dash.

22.6.1 Interior Finishes and Accessories. The interior finishes and furnishings (seats and padding) of most motor vehicles represent a significant fuel load. If the vehicle is burned out, try to determine what the original interior fuel load was and how it was arranged. Document the presence (or absence) of seats and accessory equipment such as radios, CD players, or telephones.

22.6.2 Cargo Areas. A motor vehicle fire may involve the trunk of an automobile, the storage areas of a motor home, or the cargo compartment of a truck. It is important to determine whether the fire originated in or spread to these areas. The investigator should make an inventory of the materials that were present in these areas. Inspection of the debris may be sufficient, or it may be necessary to interview owners or occupants to obtain the information needed.

22.7 Recording Motor Vehicle Fire Scenes. The same general techniques are employed for vehicles as are used for structure fires. Whenever possible, the vehicle should be examined in place at the scene. In many cases, however, the investigator may not have the opportunity to view the vehicle in place. For many reasons, the vehicle may have to be moved before the investigator reaches the scene. Frequently, part of the documentation takes place at a salvage yard, repair facility, or warehouse. A vehicle fire inspection should include the procedures in 22.7.1 through 22.7.5.

22.7.1 Vehicle Identification. Identify the vehicle to be inspected and record the information. This will entail describing it by make, model, model year, and including any other identifying features. The vehicle should be accurately identified by means of the vehicle identification number (VIN). The composition of the VIN provides information on such things as the manufacturer, country of origin, body style, engine type, model year, assembly plant, and production number. The VIN plate is most commonly placed on the dash panel in front of the driver's position. It may be affixed with rivets. If this plate survives the fire, the number should be recorded accurately. Manufacturing information is also frequently found on a combustible label on the driver's door pillar. Many manufacturers also stamp at least a partial VIN on the engine side of the bulkhead. The bulkhead may be referred to as the dash and toe panel or the fire wall. It is the partition separating the machinery compartment from the passenger compartment. A brass bristle brush will clean this number so that it is legible. If the number is rendered unreadable or appears to have been tampered with, then the assistance of one of the following should be requested:

- (1) A police auto theft unit
- (2) A member of the National Insurance Crime Bureau in the U.S.
- (3) A member of the Canadian Automobile Theft Bureau in Canada

These persons have the necessary expertise to identify the vehicle by means of confidential numbers located elsewhere

on the vehicle. The VIN should be checked on either the National Crime Information Center (NCIC) or the Canadian Police Information Centre (CPIC) to ensure that there is no record outstanding on it.

22.7.2 Vehicle Fire Scene History. For ease of discussion, the detailed examination is broken down by components or areas that have a common function. It is suggested that an attempt be made to develop a scenario of the events leading up to the fire, as well as the progression of the fire itself. To do this, it is suggested that the operator of the vehicle, passengers, bystanders, the fire department personnel, and the police be interviewed separately. This information should be used to assist with the examination. Information regarding the operation of the vehicle immediately prior to the fire should be obtained from operator and/or owner to determine the following:

- (1) When the vehicle was last driven and how far
- (2) The total mileage on the vehicle
- (3) If the vehicle was operating normally (stalling, electrical malfunctions)
- (4) When the vehicle was last serviced — oil changed, repairs
- (5) When the vehicle was last fueled and the amount of fuel
- (6) When and where the vehicle was parked
- (7) If the vehicle was seen again prior to the fire
- (8) What equipment the vehicle was equipped with — radio, CD, CB, mobile phone, electrical windows, seats, customized wheels, and so on
- (9) What personal items were in the vehicle — clothing, tools, and so on

If the vehicle was being driven at the time the fire occurred, the following additional points should be covered:

- (1) How far the vehicle had been driven
- (2) What the route of travel was
- (3) If it was loaded, towing a trailer, being driven fast, and so forth
- (4) If the vehicle was operating normally
- (5) When the vehicle was last fueled and the amount of fuel
- (6) When and where the smell, smoke, or flame was noticed first
- (7) How the vehicle reacted — stalling, racing erratically, or indications of electrical malfunctions
- (8) What the operator did
- (9) What was observed
- (10) What attempts there were to put the fire out and how
- (11) The length of time the fire burned before help arrived
- (12) The total length of time the fire burned until it was extinguished

22.7.3 Vehicle Particulars. Once the vehicle has been positively identified as being the subject of the investigation, the mechanical functions of that particular vehicle, its composition, and its fire susceptibility should be reviewed. To ensure that no details are overlooked, the investigator may examine a vehicle of similar year, make, model, and equipment, or the appropriate service manuals. The use of a checklist such as the one shown in Figure 22.7.3 may assist the investigator in the complete inspection of the vehicle. This checklist is not intended to be all inclusive. It may not apply to a given investigation and additionally may not cover all items that an investigator may identify at the scene.

FIGURE 22.7.3 Vehicle fire field notes.

VEHICLE INSPECTION FIELD NOTES					
Job # _____		Claim # _____		Date of Loss _____	
Insured _____				Date of Assignment _____	
Address (City, State) _____				Date of Receipt _____	
Loss Location _____				Date of Inspection _____	
				Insp Location _____	
Stolen? <input type="checkbox"/> Yes <input type="checkbox"/> No		Recovered By _____		at _____ on _____	
Police Report _____				Fire Report _____	
# of Keys _____		Alarm System? <input type="checkbox"/> Yes <input type="checkbox"/> No		Alarm Type _____	
Hidden Keys? <input type="checkbox"/> Yes <input type="checkbox"/> No		Location _____			
VEHICLE					
Make _____		Model _____		Year _____	
VIN _____		Odometer _____			
EXTERIOR					
Tires	Tire Type	Wheel Type	Tire Tread Depth	Lugs	Missing
LF	_____	_____	_____	_____	_____
LR	_____	_____	_____	_____	_____
RR	_____	_____	_____	_____	_____
RF	_____	_____	_____	_____	_____
SP	_____	_____	_____	_____	_____
Doors	Glass Y/N	Window UP/DOWN	(un)Locked	Open/Closed	Prior Damage
LF	_____	_____	_____	_____	_____
LR	_____	_____	_____	_____	_____
RR	_____	_____	_____	_____	_____
RF	_____	_____	_____	_____	_____
Body Panels	Construction		Condition		Prior Damage
F Bumper	_____		_____		_____
Grill	_____		_____		_____
LF Fender	_____		_____		_____
LR Quarter	_____		_____		_____
R Bumper	_____		_____		_____
RR Quarter	_____		_____		_____
RF Fender	_____		_____		_____
Hood	_____		_____		_____
Roof	_____		_____		_____
Trunk	_____		_____		_____
UNDER HOOD	Intact	Missing	Parts Missing		Condition
Engine	_____	_____	_____		_____
Battery	_____	_____	_____		_____
Belts & Hoses	_____	_____	_____		_____
Wiring	_____	_____	_____		_____
Accessories	_____	_____	_____		_____
FLUIDS	Level		Condition		Sample Taken
Oil	_____		_____		_____
Transmission	_____		_____		_____
Radiator	_____		_____		_____
Pwr Steer	_____		_____		_____
Brake	_____		_____		_____
Clutch	_____		_____		_____

(Vehicle Inspection Field Notes 1 of 2)

FIGURE 22.7.3 Continued

Job # _____

INTERIOR	Intact	Missing	Parts Missing	Condition
Dash Pod	_____	_____	_____	_____
Glove Box	_____	_____	_____	_____
Strg Column	_____	_____	_____	_____
Ignition	_____	_____	_____	_____
Front Seat	_____	_____	_____	_____
Rear Seat	_____	_____	_____	_____
Rear Deck	_____	_____	_____	_____
			Make/Model	
Stereo	_____	_____	_____	_____
Speakers	_____	_____	_____	_____
Accessories	_____	_____	_____	_____
FLOOR			Sample Taken	
LF	_____	_____	_____	_____
LR	_____	_____	_____	_____
RR	_____	_____	_____	_____
RL	_____	_____	_____	_____

PERSONAL EFFECTS IN THE INTERIOR

TRUNK OR CARGO AREA

AFTERMARKET ITEMS NOT PREVIOUSLY DESCRIBED

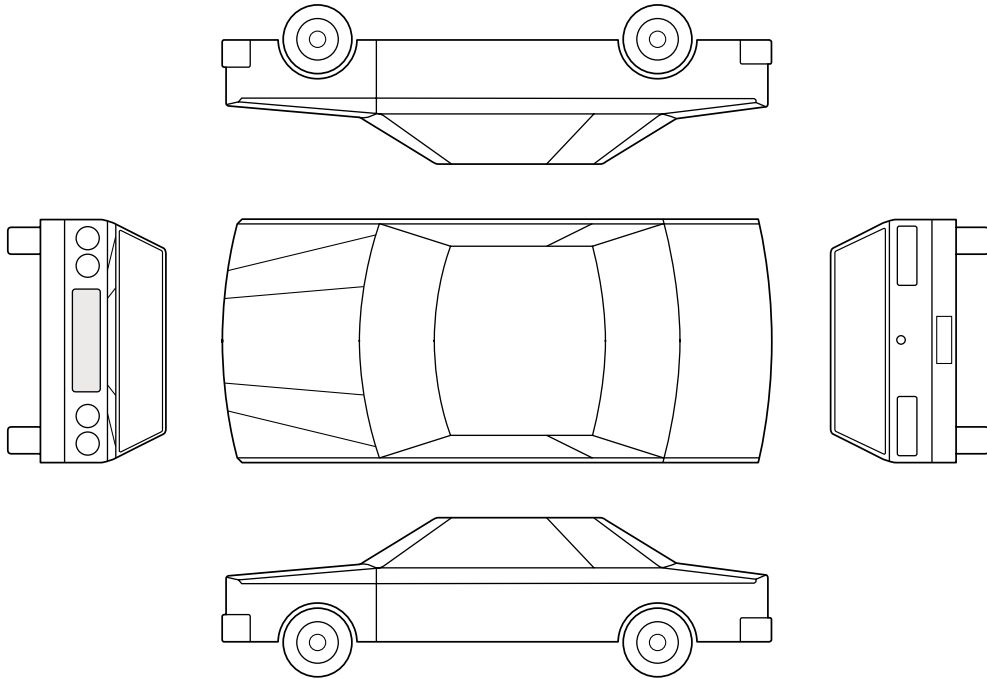

Information regarding fires and fire causes in vehicles of the same make, model, and year can be obtained from the National Highway Traffic Safety Administration, or from the Insurance Institute for Highway Safety, or from the Center for Auto Safety. All are located in Washington, DC. The DOT Auto Safety Hotline number is 1-800-424-9393 or 1-202-366-0123. The Center for Auto Safety number is 1-202-328-7700. In Canada, contact the Department of Transport, Ottawa at 1-613-998-1992.

22.7.4 Recording at the Scene. The investigator should make a diagram of the fire scene, showing points of reference and distances relative to the vehicle. The diagram should be of sufficient detail to pinpoint the location of the vehicle before its removal. The overall scene should be photographed, showing surrounding buildings, highway structures, vegetation, other vehicles, and impressions left by tires or footprints. All fire damage to any of the above items or signs of fuel discharge should be photographed and documented to help in the analysis of the fire spread. The location and condition of any parts or debris that are detached should be documented.

The vehicle should be photographed. The photographs should include all surfaces, including the top and underside. The underside can usually be documented as the vehicle is being loaded for transport. Both the damaged and undamaged areas, including the interior and exterior damage, should be photographed. Complete interior photographs should include cross views from one side to the other. Floor photographs are particularly important prior to debris removal. They will show the position of items on the floor such as contents, ignition tumblers, and keys.

Any evidence showing the path of fire spread either into or out of any compartment (engine, passenger, trunk, cargo, etc.), or within any compartment should be photographed. As with structure fires, the path of fire travel may be difficult to determine in a totally burned-out vehicle.

The cargo spaces should be photographed. The type and quantity of cargo and any involvement in the fire should be noted. If possible, the removal of the vehicle(s) and any damage that results from the removal process should be documented. Also, after removal of the vehicle(s), the scene should be photographed while noting burns on the earth or roadway, and the location of glass and other debris. Drawings and notes should be prepared to augment the photographs.

22.7.5 Recording the Vehicle Away from the Scene. If the vehicle has been removed from the scene, a visit to the scene may be helpful. Photographs that were taken at the scene should be reviewed. Prior to the vehicle inspection, as much background information should be gathered as possible. This information should include date and time of loss; location of loss; operator, passenger, or witness statements; police and fire department reports; the vehicle's current location; and method of transportation (roll-back, tow-truck, driven, etc.). The basic process of documenting the condition of the vehicle is the same regardless of where it is. When the inspection is delayed and the vehicle is located at a remote location, parts may be missing or damaged. Additionally, the vehicle(s) may have been damaged by the elements, and fire patterns, most notably those on metal surfaces, may be obscured. If outdoor storage is likely, arrangements should be made for the vehicle to be covered with a tarp or other suitable material. Often, rust developing on body panels within a few days of the fire can make burn patterns more visible, but subsequent rusting can obscure burn patterns.

Even if the vehicle was examined at the scene, there are advantages to inspecting a vehicle away from the scene. For example, it is easier to move or remove body panels that may be blocking a view of critical parts. Power is often available, as are tools for disassembly, if needed. Frequently, arrangements can be made to have equipment such as a fork-lift available to raise the vehicle for a more detailed inspection. The vehicle should be thoroughly photographed as it is examined at locations away from the scene.

22.8 Motor Vehicle Examinations. The examination of a motor vehicle after it has burned is a complex and varied task. As with structure fires, the first step is to determine an area of origin. Most motor vehicles can be divided into three major compartments: the engine compartment, the passenger compartment or interior, and the cargo compartment. The size, construction, and fuel load of these compartments can vary considerably.

Examination of the exterior may reveal significant burn patterns. The location of the fire, and the way that the windshield reacts to it, may allow a determination of the compartment of origin. Diagrams illustrating burn pattern development as a function of compartment of origin are shown in Figures 22.8(a) and 22.8(b). A passenger compartment fire will frequently cause failure at the top of the windshield and will leave radial burn patterns (burn patterns that appear to radiate from an area) on the hood, as shown in Figures 22.8(c) and 22.8(d).

Engine fires, on the other hand, typically penetrate the interior on the passenger side and will cause failure at the bottom of the windshield. Radial patterns from an engine fire may be observed on the doors. Examples of patterns produced by engine fires are shown in Figures 22.8(e) and 22.8(f).

Once a compartment of origin has been established, a detailed inspection can be made. As with a structure fire, the motor vehicle inspection should work from the area of least damage to the area of greatest damage.

FIGURE 22.8(a) Burn pattern development from an interior origin.

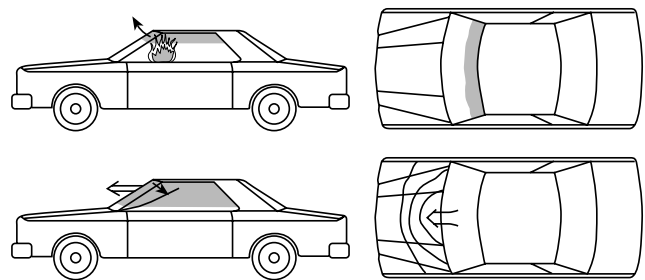

FIGURE 22.8(b) Burn pattern development from an engine compartment origin.

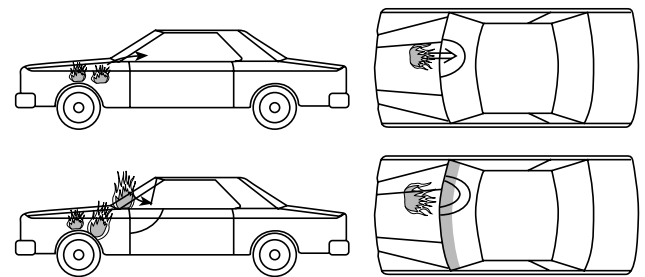

FIGURE 22.8(c) Radial burn pattern produced by a passenger compartment fire.



FIGURE 22.8(d) Radial burn pattern produced by a passenger compartment fire.



FIGURE 22.8(e) Incipient windshield failure caused by an engine compartment fire.



FIGURE 22.8(f) Radial pattern on the passenger side door produced by an engine compartment fire.



22.8.1 Examination of Vehicle Systems. After establishing a compartment of origin, the individual systems in that area can be examined. Using the system identifications and functions described in Section 22.5 through 22.5.8, an investigator should inspect a system and determine its condition and the possible involvement of that system in the fire.

Inspect the gas tank for crushing or penetrations. The condition of the fuel filler pipe. Filler pipes are often two-piece systems with a rubber or flexible polymeric connection. This connection may release fuel by failing mechanically during an accident or may burn through from an exposure fire. Some filler systems are inserted into the tank through a rubber or polymeric bushing or gasket. Accident impacts may result in disconnection of the filler neck assembly from the tank and release of fuel.

The presence or absence of the fuel tank cap and any fire or mechanical damage at the end of the filler should be noted and recorded. Many fuel tank caps have plastic or low-melting-temperature metal components that may be destroyed during the fire, with the result that the metal parts may become dislodged, missing, or found in the fuel tank. Fuel tanks exposed to heat or flame generally exhibit a line of demarcation that represents the fuel level at the time the fire was extinguished.

Fuel supply and vapor return lines should be inspected for ruptures and indications of fire damage. These lines usually have rubber or flexible polymeric connection hoses at one or more points along their length that may be points of fuel release. Examine and record the condition of lines passing near the catalytic converter and in any location where nonmetallic fuel supply or vapor return lines pass near exhaust manifolds or other sources of heat or in locations subject to abrasion.

22.8.2 Switches, Handles, Levers. During inspection of the vehicle interior, the position of switches should be noted to determine whether they were in the “on” position. An attempt should be made to determine if windows were up or down and what their condition was prior to the fire. The position of the gear shift mechanism should be noted, and the ignition switch should be examined, if possible, for any signs of a key, tampering, or breaking of the lock. Most of these elements are made of material that will be easily consumed in a fire; however, there may be enough residue left to assist in the investigation.

22.9 Total Burns. Vehicles that have burned to completion pose special problems for determining the origin and cause of the fire. If a vehicle burns to completion, there may be no witnesses to interview and possibly no fire department response. The vehicle should be identified and documented completely. An attempt should be made to determine the condition of the vehicle at the time of the fire. If components are missing, an attempt should be made to determine if they were removed prior to the fire, or removed or lost after the fire. The pre-fire condition of the engine and transmission can frequently be determined by analyzing their fluids. Fire debris from the floorboards can be checked for the presence of ignitable liquid residues.

22.10 Stolen Vehicles. Vehicles that are stolen or allegedly stolen present a special case. The likelihood that a vehicle sustained an accidental fire after being stolen is very low, but a thorough examination should still be conducted. Vehicles may be stolen for many reasons. One common motive is the theft for parts. If a thief steals a vehicle for parts, it may never be recovered. If it is recovered, it should be obvious that parts have been removed. Items of value that may be missing include wheels, most major body panels, engines and transmissions, air bags, stereos, and seats. Another common motive for vehicle theft is to commit another crime. The thief will sometimes burn the vehicle to cover any evidence such as fingerprints. This thief may not remove any item from the vehicle and may use available materials in setting the fire. Vehicles are sometimes deliberately burned and reported stolen. Such vehicles may exhibit evidence of the fraud in the form of substitution of inferior parts, such as wheels and sound systems.

Engine oil analysis may be performed to determine the pre-fire condition of the engine and possible motive for the destruction of the vehicle. Samples of debris from the floors may be analyzed for the presence of ignitable liquids. This analysis will show the method of destruction.

Assuming a total burn or near total burn, debris removal may reveal the presence of the vehicle's ignition lock cylinder tumblers. This is the portion of the ignition switch that holds the key. Careful debris removal and documentation may show the key still in the lock cylinder tumblers. In some cases, the arrangement of the tumblers in the debris will indicate whether or not the tumblers were located inside the ignition lock cylinder at the time of the fire. This information, as well as a microscopic evaluation of the tumbler lands, may show if the ignition was forced prior to the fire. If the tumblers are not found, this may indicate that the ignition lock cylinder was removed prior to the fire. The investigator may find the tumbler nearly intact in another portion of the vehicle. In this case, the tumbler will probably show evidence of forced removal.

22.11 Vehicles in Structures. Motor vehicles are often stored in structures and may be damaged by a fire that occurs within the structure. The damage may include thermal effects of the fire and crushing of the vehicle by collapse of the structure. If the vehicle is located in the area of origin, then it should be examined as a potential fire cause, as outlined in Sections 22.5 through 22.10. Conducting a thorough examination of this vehicle may include removing it from the debris, removing the hood and roof, removing debris from the interior, and elevating the vehicle to examine its underside.

Fires that start external to the vehicle may spread to the vehicle and cause the vehicle to sustain significant damage. External fire may also cause loss of integrity of fuel or other system components, including fuel lines and tanks, and may cause the release of ignitable liquids.

Vehicles that are in structures may be there for repair or rebuilding purposes. It is important to document the state of these efforts at the time of the fire.

22.12 Recreational Vehicles. Recreational vehicles (and motor homes) and fires in them are similar in many ways to houses and mobile homes. Plywood flooring and paneling may be present, and there will often be large fuel items like polyurethane foam couches or mattresses. The examination should note the appliances present. Obtaining catalogs or sales brochures for these vehicles can help determine what appliances and furniture were present before the fire.

As with all the other types of inspections, proper background checks of prior problems, recalls, repairs, and malfunctions should be obtained. In some cases, appliances designed for residential uses, such as a refrigerator or a furnace, will be placed in a recreational vehicle as a replacement for the original item. Often, these items require different clearances and power supplies to operate properly.

On RVs, tolerances and clearances designed into the coach are sometimes critical, depending on the system. In removing any of these items, the investigator can destroy key pieces of information relevant to a potential cause. (*See Section 14.3.*)

22.13 Heavy Equipment. Heavy equipment includes earth moving, mining, forestry, landfill, and agricultural equipment. These vehicles have a significant materials-handling function in addition to the locomotive function. This equipment is usually diesel powered and usually has a hydraulic transmission. Heavy equipment is subject to the same failure modes as ordinary vehicles, but it is also susceptible to failure due to overloading the transmission, failure of the hydraulics involved in materials handling, bearing failures, and ignition of the material being handled. Investigation of a heavy equipment fire requires a knowledge of the systems involved, including the specific systems peculiar to that type of vehicle. Some heavy equipment is equipped with fixed suppression systems. Suppression systems for surface mining equipment are discussed in NFPA 121, *Standard on Fire Protection for Self-Propelled and Mobile Surface Mining Equipment*.

Chapter 23 Wildfire Investigations

23.1 Introduction. Wildfire investigation involves specialized techniques, practices, equipment, and terminology. While the basic principles of fire science and dynamics are the same, in a wildfire scenario, the fire development and spread is influenced by different and sometimes additional factors.

The purpose of this chapter is to identify and explain those aspects unique to wildfire investigation. This is a subject matter with varying levels of expertise, and this chapter is intended as a basic introduction. As with other types of fire investigation covered in this guide, specialized personnel may be needed to provide technical assistance.

Wildfire fuels are classified as woody or herbaceous vegetation. These materials ignite at a range of temperatures, depending on their moisture content, oil content, and mineral content. The ease of ignition of materials is dependent upon the size and nature of the fuels, oil and mineral content, the weather conditions, topography, and aspect. When exposed to sunny days for a period of time, the fuel dries, allowing easier ignition and spread. Conversely, during humid or wet weather or in shady areas, the fuel absorbs moisture, thereby requiring longer exposure time or higher temperatures for ignition. Topography not only affects fire spread due to physics but also affects the ease of ignition, due to wind,

shade, and other factors that influence the moisture content and temperature of the fuels.

As an example, an acknowledged cause of wildfire is burning carbon particles from engine exhaust, but even then, ignition is dependent on levels of relative humidity; fuel moisture content, size, density, and arrangements; and temperature of the fuels.

In a wildfire, fire spread is influenced by convected and radiant heat. Convected heat allows the fire to spread from the lower level grasses and duff to the upper level branches and crowns. Radiant heat then becomes dominant as the primary heat transfer method, as the fire progresses laterally. Radiant heat is the dominant heat transfer method in lower level fuels, comprised of brush and grass on level surfaces.

23.2 Wildfire Fuels. Keen observation of variations in wildfire fuels is essential in analyzing fire behavior reliably.

23.2.1 Flammability Analysis. In a wildland, great differences exist in the character of flammable materials. Deep duff, newly fallen dead leaves, clumps of grass, litters of dry twigs and branches, downed logs, low shrubs, green tree branches, hanging moss, snags, and many other types of material are present. Each of these materials has distinctive burning characteristics. The flammability of a particular fuel body is governed by the burning characteristics of individual materials and by the combined effects of the various types of materials present.

Before flammability can be analyzed, the physical characteristics of combustible wildland materials must be classified. Such a classification permits the identification of the fuel factors that influence flammability. After the fuel has been classified properly, topographic and weather factors must be considered before the rate of spread and the general behavior of fires in that fuel can be determined.

Because forest fuels are so varied and complex, it is necessary to develop a systematic approach to flammability analysis. First, the fuel body is subdivided into two broad classes, ground fuels and aerial fuels. Then each of these classes is evaluated according to the arrangement, compactness, continuity, volume, and moisture content of the principal materials involved. Aspect also affects the flammability of fuels: south-west-facing slopes heat up to a greater extent. With practice, this procedure can be performed quickly and easily.

23.2.2 Ground Fuels. Ground fuels include all flammable materials lying on or immediately above the ground or in the ground. The principal materials may include duff, peat soils, tree roots, dead leaves and coniferous litter, grass, fine dead wood, downed logs, stumps, large limbs, low brush and young stands of trees.

23.2.2.1 Duff. Duff seldom has a major influence on the spread rate of fire, as it is typically moist and tightly compressed so that little of its surface is freely exposed to air, and its rate of combustion is slow. In forest fires, most of the duff is consumed down to mineral soil. Occasionally, duff contributes to the rate of spread by furnishing a path for the fire to creep along between patches of more flammable material.

23.2.2.2 Roots. Roots are not an important factor in rate of fire spread, as the greatly restricted air supply prevents rapid combustion. However, fires can creep slowly in roots — in fact, some fires have escaped control because a root provided an avenue for the fire to cross the control line. The most flammable roots are the large laterals stemming from dead snags.

23.2.2.3 Dead Leaves and Coniferous Litter. As leaves and coniferous litter decay on the ground, they gradually become part of the duff layer. Before this decay takes place, however,

leaves and coniferous litter are a highly flammable material and should be considered separately in evaluating ground fuels. In many forests, surface fuels are composed primarily of needles dropped from coniferous trees. Ponderosa pine needles, for example, are extremely flammable because their large size and shape create a loose arrangement, allowing free circulation of air. Smaller needles, like those of Douglas fir, generally burn less intensely, as they are more tightly compacted on the ground.

Needles that are still attached to dead branches are especially flammable because they are exposed freely to air and are not typically in direct contact with the more moist material on the ground. Needles remaining on fallen limbs form highly combustible kindling for larger material. For this reason, logging slash containing dry needles is dangerous fuel.

23.2.2.4 Grass. Grass, weeds, and other small plants are important ground fuels that influence rate of fire spread. The key factor in these fuels is the degree of curing. Succulent green grass acts as a fire barrier. During the course of a normal fire season, however, grass gradually becomes drier and more flammable as the plant cures or as the stems and leaves die due to lack of moisture. At this time, the grass cover becomes easily ignitable. Cured grass, if present in a large and uniform volume, becomes the most flammable, fastest spreading ground fuel.

Grass and other small plants occur on the floor of almost all forests. Fire investigators need to determine the volume and continuity of the grass cover. In dense forests where little sunlight reaches the ground, very little grass is found. In more open forests, such as in mature stands of pine, there may be a large amount. If there is a more-or-less continuous cover of dry grass on the forest floor, the spread rate of a fire will be governed largely by that cover, rather than by the heavier fuels normally associated with a forest. Fires in dry grass often have high rates of spread.

23.2.2.5 Fine Dead Wood. Fine dead wood consists of twigs, small limbs, bark, and rotting material. Normally, the fine dead wood classification is confined to material with a diameter of less than 2 in. (50.8 mm). These fine dead ground fuels are among the most important of all materials influencing the rate of fire spread and general fire behavior in forest areas. Fine dead wood ignites easily and often provides the main avenue for carrying fire from one area to another. It is the kindling material for larger, heavier fuels.

In areas where a great volume of fine dead wood exists, a fire can rapidly develop tremendous heat. The greatest volume of fine dead wood is usually found in areas containing logging slash. Under dry conditions, fires in such areas burn violently, and the strong convection currents created by the intense heat pick up burning embers and throw them out ahead, causing spot fires beyond the main fire front.

Granulated dry rotten wood, while not an especially important factor in the rate of fire spread, is a highly ignitable fuel. Flying embers from the main fire often cause spot fires in rotten wood lying on the ground or in hollow places on old logs or stumps.

23.2.2.6 Downed Logs, Stumps, and Large Limbs. Heavy fuels, such as downed logs, stumps, and large limbs, require long periods of hot, dry weather before they become highly flammable. When such material reaches a dry state, however, very hot fires may develop. The most dangerous heavy fuels are those containing stringers of dry wood, shaggy bark, or many large checks and cracks. Smooth-surfaced material is less flammable, as it dries out more slowly, has little surface exposed to air, and contains less attached kindling fuel.

Extremely hot fires may develop in piles of downed logs and large limbs or in crisscrossed windfalls, as the various fuel components radiate heat to each other. Individual limbs and logs will not burn very hot unless the fire is supported by large accumulations of fine dead wood.

23.2.2.7 Low Brush and Reproduction. Low brush, tree seedlings, and small saplings are classified as ground fuels because they are so closely intermixed with the flammable material on the forest floor. This understory vegetation may either accelerate or slow down the spread rate of a fire. During the early part of a fire season, the shade normally provided by understory vegetation prevents other ground fuels from drying out rapidly. As the season progresses, however, continued high air temperature and low relative humidity dry out both the fuel lying on the ground and the understory vegetation. When this happens, most of the low vegetation, particularly small coniferous trees, become fire carriers.

The understory vegetation in a forest often provides a link between ground fuels and aerial fuels. The crowns of small trees may catch fire and, in turn, spread the fire to aerial fuels in the forest canopy. Either thickets of reproduction or dead brush may provide the first means for a surface fire to flare up and spread into the crowns of the overstory trees.

23.2.3 Aerial Fuels. Aerial fuels include all green and dead materials located in the upper forest canopy. The main aerial fuel components are tree branches, crowns, snags, moss, and high brush.

23.2.3.1 Tree Branches and Crowns. The live needles of coniferous trees are a highly flammable fuel. Their arrangements on the tree branches allow free circulation of air. In addition, the upper branches of trees are more freely exposed to wind and sun than most ground fuels. These factors, plus the volatile oils and resins in coniferous needles, make tree branches and crowns important components in aerial fuels.

Tree branches and crowns are fuels that can flash quickly with changes in relative humidity. Crown fires seldom occur when relative humidity is high. However, coniferous needles dry out quickly when exposed to hot, dry air. The dryness of needles is influenced by the transpiration process in a tree. When the ground is moist, trees pump a large amount of moisture into the air through the leaves. As the ground becomes drier, the transpiration process slows, and, as a result, leaves and branches become drier and more flammable.

Dead branches on trees are an important aerial fuel. Concentrations of dead branches, such as those found in insect- or disease-killed stands, may cause fire to spread from tree to tree. Concentrations of dead branches on the lower trunks of trees may provide an additional avenue for fires to spread from ground fuels into tree crowns. The most flammable dead branches are those still containing needles.

23.2.3.2 Snags. Snags, or tree stumps, are one of the most important aerial fuels that influence fire behavior. Although green trees greatly outnumber snags in most forests, fires start in snags because they are drier and much easier to ignite.

Snags vary widely in character and, consequently, in their effect on fire behavior. Smooth, solid snags that contain very little bark and few checks or cracks are not highly flammable. On the other hand, broken-topped, shaggy-barked, or partially decayed snags ignite easily and have a major influence on the spread of fires. Burning embers blown from shaggy-barked snags are prolific starters of spot fires. In areas containing large numbers of snags, fire may spread from one trunk to another because of the intense radiation of heat.

23.2.3.3 Tree Moss. Moss hanging on trees is the lightest and the most apt to flash of all aerial fuels. Moss is important principally because it provides a means of spreading fires from ground fuels to other aerial fuels or from one aerial component to another. Like other light fuels, moss reacts quickly to changes in relative humidity. During dry weather, crown fires may develop easily in heavily moss-covered stands.

23.2.3.4 High Brush. Crowns of high brush are classified as aerial fuels because they are separated distinctly by distance from ground fuels. In many forest regions, heavy stands of brush may develop in old burns, and they often form the principal vegetative cover in such areas. Crown fires in brush fuels ordinarily do not occur unless heavy ground fuels are present to develop the required heat. In some brush stands, however, a high proportion of dead stems may create a sufficient volume of fine dead aerial fuels to permit very hot and fast-spreading crown fires. Key factors in evaluating the behavior of fires in high brush are volume, arrangement, the general condition of ground fuels, and the presence of fine dead aerial fuels.

23.3 Factors Affecting Fire Spread. Major factors to be considered in the determination of the possible area of fire origin is the wind speed and direction. These factors relate directly to the resulting speed of the fire spread. This is most easily observed when working backward from the position of the fire head, flank, or heel.

23.3.1 Lateral Confinement. When wildfires are confined by landforms such as gullies, ravines, or narrow valleys, convective heating by confined gases and radiation feedback from flames and burning vegetation increases the heat release rate of the burning fuels. These factors may result in a more rapid combustion and spread than that of an unconfined vegetation fire.

23.3.2 Wind Influence. Wind greatly affects the speed at which a fire will spread. The fanning effects of the wind push the flame ahead, resulting in a preheating of the fuel. The wind also assists in drying out vegetation, increasing the ease of ignition. Wind further results in the creation of airborne firebrands, carried aloft by the heated convective air column. The accompanying fire wind can blow embers and hot sparks ahead of the main fire to ignite secondary fires in areas of unburned fuel. Three different types of wind influencing fire behavior are classified as meteorological, diurnal, and fire winds.

23.3.2.1 Meteorological Winds. Meteorological wind is caused by atmospheric pressure differentials in upper level air masses that generate regional weather patterns. The earth's rotation, oceans, and topographic features create these major air movements to form wind and pressure belts.

23.3.2.2 Diurnal Winds. Diurnal winds are formed by solar heating and nighttime cooling. As air warms during daytime, the rising air creates upslope winds. When air cools after sunset, this denser, heavier air sinks and causes downslope winds.

23.3.2.3 Fire Winds. Fire winds are caused by the fire itself. These winds are the result of the entrainment of air by the rising fire plume. Fire winds influence the spread of the fire.

23.3.3 Fire Head. The portion of a fire that is moving most rapidly is called the *fire head*. The direction the local wind is blowing while the fire is burning primarily determines the route of the head's advance, subject to influences of slope and other topographic features. Large fires burning in more than one drainage or fuel type can develop additional heads. The head is generally the area of most intense burning and greatest fire intensity.

23.3.4 Fire Heel. The fire heel is located at the opposite side of the fire from the head. The fire at the heel is less intense and is easier to control. Generally, the heel will be backing or burning slowly against the wind or downhill.

23.3.5 Fuel Influence. Fuel type and characteristics provide the second greatest influence on the rate of spread and intensity of the fire.

23.3.5.1 Species. The species involved can determine the rate of spread and intensity of the fire. Each type of vegetation has different characteristics, that is, size, moisture content, shape, and density.

23.3.5.2 Fuel Size. A major factor governing the ignitability and burning rate of a fuel is its size. The smaller the fuel element (surface area to mass ratio), the easier it will be to ignite and the faster it will be consumed. These smaller fuels are classified as fine fuels and are comprised of such items as seedlings and small trees, twigs, dry grass, brush, dry field crops, and pine needles and cones. Larger diameter fuels, classified as heavy fuels, are much more difficult to ignite and burn slower than light fuels. Most often, it requires burning light fuels to serve as kindling to ignite the heavier fuels. Some examples of heavy fuels are large-diameter trees and brush, large limbs, logs, and stumps.

23.3.5.3 Moisture Content. The amount of moisture present in the fuel plays a major role in determining the ignitability and the rate of fire spread. As the vegetation (fuel) dries out, it becomes more readily ignitable and will burn with greater intensity. Green vegetation, or vegetation having greater moisture content is more difficult to ignite and will burn more slowly due to the moisture within the vegetation absorbing the heat during evaporation. Once the moisture is removed, the temperature will continue to rise to the fuel's ignition temperature. The moisture content of the fuel will vary, depending on the type and condition of the vegetation, solar exposure, weather, and geographic location.

23.3.5.4 Oil Content. The amount of oil within vegetation likewise plays a role in the fuel's ease of ignition, fire intensity, and spread factors.

23.3.5.5 Fuel Types: Ground, Surface, and Crown. Fuels can be arranged into three different categories: ground fuels, surface fuels, and crown fuels. Ground fuels lie between the ground surface and mineral soil. Examples are decomposing matter, peat, duff, and roots. Ground fuels, such as roots or buried lengths of wood, can burn along their entire length underground and can ignite a surface fire in a different location. Surface fuels include grasses, leaves, twigs, needles, field crops, slash, and downed limbs. Anything under 6 ft (2 m) in height can be considered surface fuel. Crown fuels, in the tops of trees, are separated from surface fuels. They are typically considered fuels greater than 6 ft (2 m) in height. Examples are hanging mosses, branches, limbs, leaves, needles, and tree crowns.

The sparseness or density of the fuel cover is the basic factor in fire propagation. Sparse fuels may be too widely spaced for the fire to preheat neighboring fuels to their ignition temperature. On the other hand, fuels in close proximity can cause increased fire intensity, extend flame lengths, and accelerate fire spread.

23.3.6 Topography. Topography relates to the form of natural or man-made earth surfaces. Topography affects the intensity and spread of a fire. Winds, as well, are greatly affected by the topography of the land.

23.3.6.1 Slope. A topographical feature that has a resounding effect on fire spread is slope. The slope of an area is determined by measuring the rise over run, or the change in elevation over a given distance and is often expressed as top third, middle third, and bottom third. Slope allows the fuel on the uphill side to be preheated more rapidly than if it were on level ground. This allows the fire to burn with more intensity and speed. Wind currents, which prevalently move uphill during the day, can accelerate the fire uphill at alarming rates. Slope may also result in burning logs and embers rolling down the hill, starting spot fires below the primary fire and across control lines.

23.3.6.2 Aspect. The aspect of the slope is the direction in which the slope faces. This is an important consideration because of solar heating (or lack thereof) on the fuel and ground surface, raising the potential for ignition, and increasing the rate of spread. Slopes facing the sun are typically drier, and they may have a more combustible fuel type or character of vegetation than nonfacing slopes, resulting in a greater ease of ignition and faster spread. Scant rainfall and poor soil quality may create a sparse fuel supply, inadequate to support fire spread unless extremely strong winds are present.

23.3.7 Weather. Weather plays a substantial role in the behavior of wildfires. Weather elements can be described as the state of the atmosphere with respect to atmospheric stability, temperature, relative humidity, wind velocity, cloud cover, and precipitation.

23.3.7.1 Weather History. An important item to consider during an investigation is the weather history. Weather history is a description of atmospheric conditions over the preceding few days or several weeks. Weather elements should be analyzed to determine what influences they may have had on the fire's ignition and burning characteristics.

23.3.7.2 Temperature. The temperature of the ambient air directly influences the temperature of the fuel. The sun is one factor that affects temperature. As the radiant solar energy of the sun heats the ground and vegetation, the fuel becomes more susceptible to ignition. Temperature differences of more than 50°F can occur between shaded areas and areas exposed to direct sunlight. Another factor influencing temperature is altitude. The lower air pressure at high altitudes allows the air to expand and cool.

23.3.7.3 Relative Humidity. Humidity is the measure of water vapor suspended in air. Humidity is usually expressed as relative humidity, which is the ratio of the amount of moisture in the air to the amount that known volume of air can hold, expressed as a percentage. The moisture in the air directly affects the amount of fuel moisture and vice versa. Dry air will draw moisture out of the vegetation, making it more susceptible to fire. Fine fuels are more responsive to relative humidity than are large fuels. If the air has a high relative humidity, the vegetation will take in some of that moisture, making it less susceptible to ignition, or the moisture may slow the rate of spread of a fire in progress. Warm air can hold more water than can cool air. This is illustrated by early morning dew. As the night air cools, the air loses its ability to hold moisture. The moisture condenses at the air's dew point and forms the dew.

23.3.8 Suppression. Fire suppression is the combination of all activities that lead to the extinguishment of the fire. Suppression includes everything from the initial stage of fire discovery to the final stage of completely extinguishing the fire. Protection by fire crews of potential areas of origin is of

extreme importance in establishing the fire origin and cause. It may be useful for the investigator to review and analyze the fire suppression tactics and their effects on spread to assist in identifying the fire origin.

23.3.8.1 Fire Breaks. Fire breaks, fire lines, or control lines are any natural or man-made barriers used to stop the spread or reroute the direction of the fire by separating the fuel from the fire. Natural fire break examples are bodies of water, cliffs, and areas lacking vegetation. Examples of man-made breaks include roads, fire lines, pre-burned areas, and water or retardant or foam barriers.

23.3.8.2 Air Drops. An air drop is the aerial application of water, slurry, or retardant mixture directly onto the fire, onto the threatened area, or along a strategic position ahead of the fire. Aircraft also drop retardant on uninvolved areas to stop or slow the spread of fire. Air drops may alter fire indicators in or near drop zones.

23.3.8.3 Firing Out. Firing out is the process of burning the fuel between a fire break and the approaching fire to extend the width of the fire barrier. It is used as an offensive attack on the fire and should be done only by experienced personnel. These fires are normally started at a fire control line (normally on the downwind side of the fire) and are burned back toward the leading edge of the fire. Several different sources of ignition are used, including drip torches, fusees, matches and Helio torches.

23.3.8.4 Class A Foam. Class A foam is a mechanically generated aggregation of bubbles that have a lower density than water. The foam is made by introducing air into a mixture of water and foam concentrate.

The bubbles adhere to the wildfire fuels or other Class A fuels and gradually release the moisture they contain. Bubbly water adsorbs heat more efficiently than plain water, and the bubble mass provides a barrier to oxygen, necessary to sustain combustion. The reduced rate of water release results in more efficient conversion of water to steam, providing enhanced cooling effects and, along with surfactant contained in the solution, allows the water to penetrate the fuels and reach deep-seated fires. The bubble mass also provides a protective barrier for unburned and exposed fuels.

23.3.9 Other Natural Mechanisms of Fire Spread. The direction and rate of fire spread may be altered by natural or self-induced means.

23.3.9.1 Wind-Borne Embers and Firebrands. Hot embers and brands can be picked up by wind and blown into unburned fuel great distances from the original fire. These embers often start what are known as *spot fires*. In some instances, these secondary fire origins may be mistaken for separate fires set by an arsonist.

23.3.9.2 Fire Storms. A fire storm is an intense and violent convection fire, fed by self-induced winds. The indrafts created by the fire's convection column may be strong enough to uproot vegetation and propel small rocks. One characteristic of a fire storm is the tornadic fire whirls, which accompany the powerful indrafts.

23.3.10 Wildland–Urban Interface. Wildland–urban interface can be described as a region in which the hazard of combustible wildland fuels and structures such as homes are found in the same vicinity. NFPA 299, *Standard for Protection of Life and Property from Wildfire*, defines urban interface as “an area where improved property and wildland fuels meet at a well-defined boundary.” In these situations, the investigator must determine if the fire began

at the structure or in the wildland area. These areas are an easy target for arsonists because of the extended response time of emergency personnel that results from difficulty in traversing narrow roads and trouble in locating the fire.

23.3.11 Animals. Animals and birds can spread fire from flaming fur or feathers. Animals have been set afire accidentally and deliberately to start a wildfire or, as a fire victim, burned animals can start fires in unburned areas during their flight. A bird's feathers or an animal's fur can be ignited by contact with power lines and can start a wildfire when the electrocuted body falls to the ground.

23.4 Indicators. The indication of the direction of a fire's spread is imprinted on partially burned fuels and noncombustible objects. These visual indicators may include differential damage, char patterns, discoloration, carbon staining, shape, location and condition of residual unburned fuel. Analysis of the directional pattern shown by multiple indicators in a specific area will identify the path of fire spread through this site. By applying a systematic approach to backtrack the progress of the fire, the investigator can retrace the path of the fire to the point of origin. This procedure is the accepted and standard technique in wildfire investigation.

23.4.1 Wildfire “V”-Shaped Patterns. Wildfire “V”-shaped patterns are horizontal ground surface burn patterns generated by the fire spread. When viewed from above, they are generally shaped like the letter “V.” These are not to be confused with the traditional plume-generated vertical V patterns associated with the structure fire investigations.

These V-shaped patterns are affected by wind direction, or the slope on which the fuel is located. As the fire spreads in the direction of the wind or up a slope, the widening legs of the V are created. The width of the pattern increases as the fire advances from the area of ignition. The origin of the heat source that created the pattern often is found at or near the base or most narrow point of the pattern. Therefore, the analysis of these horizontal V-shaped patterns can be useful in identifying a general location of the fire origin.

23.4.2 Degree of Damage. The degree of damage to fuels is an indication of the intensity and the direction of fire passage. Leaves, branches and limbs will show greater damage on the side from which the fire approached. This is one of the useful indicators in determining the direction of frontal fire spread. Also, items lying on and protecting fuels leave a pattern that can assist in locating the origin. Vegetation on the side of an object exposed to an oncoming fire front will be burned away, while the basal stems of vegetation adjacent to the reverse (shielded) side will remain only partially burned. Also, items lying on and protecting fuels leave a similar pattern on residual vegetation.

23.4.3 Grass Stems. As a low-intensity fire burns through the bottoms of grass stems, the stems topple over into the fire. If those stems fall into burned area behind the head, they may stay unburned. Grass stems that fall ahead of the fire or topple against adjacent unburned fuels will be consumed by the oncoming fire. Therefore, unburned grass stalks or seed heads observed lying on the ground will generally point in the direction the fire approached and opposite the fire spread direction.

23.4.4 Brush. More upper foliage will be burned on the exit side, and some upper branch tips will fall unburned to the ground on the entry side. The lower stem bundle will be burned more deeply from direct exposure to the approaching frontal fire.

23.4.4.1 Ash Deposits. Ash will not be found on fuels that were still burning when the ash came to rest. The pattern of ashes when found often will reveal wind direction. Fuel volume can be reconstructed with fair accuracy from the amount of ash present.

23.4.4.2 Cupping. Cupping normally occurs on the windward side of a stub of timber, brush, or grass. This is the side exposed to the most wind and should be expected to char the deepest, while the other side remains relatively cooler and protected by the remains of the exposed side. This effect takes place even in grass, which can be examined closely by rubbing the back of the wrist over the burned grass. When rubbed in the direction that the fire burned, there will be a velvety feeling but when rubbing in the opposite direction, there will be a feeling of some suction and a prickling on the wrist. The hand should be moved in all directions until the most velvety and most resistant directions are established.

The tips of burned stubs will be blunt or cupped on the upwind side, whereas burned stubs on the downwind side will be sharp and point in the direction of fire travel.

23.4.4.3 Die-Out Pattern. Fires that die out after entering brush growth will show decreasing fire intensity, charring, and burned branch size.

23.4.5 Trees. Trees are significant indicators of fire direction, particularly in areas of frontal fire damage. Fire movement is recorded at ground level around the root base and tree trunk and at flame height by the lower foliage and crown canopy.

23.4.5.1 Trunk Char. The angle of char on opposite sides of a tree trunk will indicate direction of fire spread, but indicators are affected by slope and wind direction. When fire burns upslope in an upslope wind, the angle of char on the tree will be greater than the slope angle of the hill. When fire burns downhill against an upslope wind, the char line on the tree will be nearly parallel to the slope of the hill. When fire burns downslope in a downslope wind, the angle of tree char will be higher on the downhill side because of the wrapping, eddy effect on the back of the tree. When fire burns upslope in a downslope wind, the char angle will be about level with the slope of the hill, with only light upslope damage of the tree trunk.

23.4.5.2 Crown Damage. Convection and radiant fire heat will ignite the lower tree limbs to spread rapidly upward through the tree canopy into crown branches. This sequence can repeat several times in different fuel packages until succeeding torch-like events have burned away the fuel supply. Wind action will drive the fire away from windward foliage and branches, reducing damage or leaving a triangular unburned area on the windward (approaching fire) side of the crown.

23.4.6 Noncombustibles. Items left behind by the fire can leave clues as to how the fire burned. Soot stains left on noncombustible items can tell the investigator how intensely the fire burned and the direction of fire travel.

23.4.6.1 Exposed and Protected Fuels. Protected areas may be observed when fuels are covered by another object or shielded by being on the opposite side of the approaching fire. Items directly exposed to the fire are susceptible to much deeper charring or staining than are unexposed or protected items. If an object has been lying on the fuel, it will protect that fuel from burning, and a distinct burn pattern will be left behind. The exposed, or fire, side of the pattern will have a defined line of demarcation beside the object. The opposite

(shielded) side will have a varying, or less defined, damage outline along the object edge, creating a shadow of the object.

23.4.6.2 Staining and Sooting. Rocks, cans, wood and metal fences, posts and unburned vegetation will be stained by oncoming fire on their exposed side. The staining is caused by small ash particles and airborne oils being deposited on the surface of the object. Carbon soot does the same thing to objects, but is caused by incomplete combustion and the natural fatty oil content in some vegetation. These fire products are typically more heavily deposited on the side facing the approaching fire.

23.4.6.3 Loss of Material. As materials heat up, they undergo physical change. Typically, when wood or other combustible surfaces burn, they lose material and mass. The shapes and quantities of remaining combustibles can themselves produce lines of demarcation and, ultimately, fire patterns to be analyzed by the investigator. (See 4.3.4.)

23.5 Origin Investigation. The first objective of a wildfire investigation is to identify the area of origin. Considering the factors of wind, topography, and fuels, the origin is normally located close to the heel or rear of the fire.

23.5.1 Initial Area of Investigation. The initial area of investigation can be determined from information from first-arriving fire fighters and eyewitnesses. The fire fighters and witnesses can verify the location and size of the fire during its early involvement. These accounts will assist the investigator in narrowing down the search area.

23.5.1.1 Observations of Reporting Parties. The reporting party or parties may have seen the fire at an early stage and can provide valuable information that may assist in determining origin and cause. The observations of the reporting parties are important because origin investigation can be narrowed to the area burned at the time of the report. They may also be able to verify or supplement some of the information obtained from other witnesses and attack crews.

23.5.1.2 Observation of Initial Attack Crew. The initial attack crew can play a vital role in the investigation by making observations while en route and upon arrival on the scene. Crew members may be able to provide valuable information pertaining to both the investigative area and the identification of people or vehicles leaving the area, the weather, locks and gates that have been tampered with, and other damage or abnormal conditions. Also, if any potential evidence is found, it should be marked and protected. Questions to ask first-arriving crews include the location of the fire upon arrival, the direction the fire was spreading, descriptions of persons or vehicles in or leaving the area, and weather conditions.

23.5.1.3 Observations of Airborne Personnel. Airborne personnel can make the same types of observations as ground crews: the potential area of origin, direction of fire spread, and people or vehicles leaving the area. The information should be passed (along) to ground personnel promptly and as accurately as possible. Photographs of the fire area taken by airborne personnel often prove invaluable in showing areas burnt, the direction of fire travel, and intensity at a given location and point in time.

23.5.1.4 Observations of Other Witnesses. Witnesses can often provide vital information in the investigation of a wildfire. Witnesses can provide information about unfamiliar vehicles or people that may have been in the area. They are often familiar with the area and can give information as to the area of origin and a

possible cause. They can also provide information on the condition of the fire, such as smoke conditions, intensity, rate of spread, and weather.

23.5.1.5 Satellite Imaging or Remote Sensing. Satellite or imaging tools that are used primarily to establish fire suppression tactics may likewise be utilized to assist in the establishment of the area of origin, based on the direction of fire spread and data indicating the fire location when first detected.

23.5.2 Search Techniques. Once the location of the fire origin has been determined, the cause of the fire's ignition must still be determined. The search for an ignition source may include several techniques.

23.5.2.1 Protection of Fire Scene. The integrity of the fire scene needs to be preserved. Foot and vehicle traffic moving through the area must be kept to a minimum. If the situation allows, the area can be cordoned off by the use of flags, tape, or personnel posted at the scene.

23.5.2.2 Identifying Evidence. During the investigation, metal flagging stakes can be used to mark items that could be considered potential evidence. Labeled flags can also be used to mark the position of an item of evidence that has been removed from the scene.

23.5.2.3 Analyzing Fire Spread. Analyzing fire spread may involve many steps. It may begin with establishing and plotting the location of the head, flanks, and heel of the fire when it was discovered, as well as at the time of arrival. Wind direction and available weather information should be documented and plotted, based upon the observations of those who discovered the fire.

23.5.2.4 Origin Area. Care must be continually exercised not to destroy evidence or other signs, such as tracks left by individuals or vehicles in the suspected area or areas of origin. Whenever the source of ignition is found at a confirmed point of origin, the surrounding area must be examined to determine if a match or other ignition device was discarded nearby by the person who started the fire.

23.5.2.4.1 Segment Division. If the identified area of origin is very small, the area can be searched in its entirety from its perimeter. However, if the area is large, the site should be broken down into segments for a systematic close-up examination. These segments allow the investigator to focus on a small section of the area, as well as to eliminate re-examining areas that have already been searched. When finished with one section, the investigator moves to the next section.

23.5.2.4.2 Loop Technique. The loop technique is also referred to as the spiral method. This method is effective in a small area; however, as the loop or circle widens, evidence can be more easily overlooked, or even damaged as the investigator moves into the area of origin.

23.5.2.4.3 Grid Technique. This is one of the best procedures for covering a large area with more than one searcher. The searchers move parallel to one another and cover the same area twice. There are a number of variations of this method. The grid method is considered the most thorough system for covering a large area with a number of searchers.

23.5.2.4.4 Lane Technique. The lane technique is also referred to as the strip method. This method can be used effectively if the area to be covered is large and open. It is relatively quick and simple to implement and may even be performed by a single investigator in small areas.

23.5.3 Search Equipment. Different tools are used by investigators in search of the cause and origin of wildfires.

23.5.3.1 Magnifying Glass. A magnifying glass allows the investigator to see evidence that may not be visible without some sort of magnification. It also enhances small details that would otherwise go unnoticed.

23.5.3.2 Magnet. Magnets with a rating of at least 30 pounds are used to locate ferrous metal fragments or particles. Moving a magnet over the burned area will cause such materials to be attracted to the magnet. The magnet should be covered by a plastic bag while being swept over the ground surface to prevent extraneous materials from being collected on the magnet surface and, when an item of evidence is found, the bag can be inverted as it is separated from the magnet to retain the evidence. A roofers' magnet mounted on wheels is invaluable when examining large, flat areas.

23.5.3.3 Straight Edge. A straight edge can be used to segment the origin area. By reducing the search area, the investigator will find it easier to focus on small objects. This is very helpful when using a magnifying glass.

23.5.3.4 Probe. A probe is particularly useful in uncovering small pieces of evidence from the surrounding vegetation, for example, removing grass stems from the underlying matchbook.

23.5.3.5 Comb. A wide-gap comb can be used to separate evidence from debris. It also works well for picking up evidence without damaging it. By using the comb like a scoop, the investigator can pick up small pieces of evidence while letting burnt grass and other debris sift out through the teeth. Hair picks work exceptionally well for this task.

23.5.3.6 Hand-Held Lights. Hand-held lights assist in locating items in low-light areas. They also eliminate shadows.

23.5.3.7 Air Blower. A small air blower (sold for camera cleaning) is useful to separate light ash from items of interest. Air expelled through pursed lips provides similar results, but is not as controlled.

23.5.3.8 Metal Detector. Metal detectors provide the location of metals that may be of evidentiary value and that could not be easily located by a magnet or are in rough surface areas.

23.5.3.9 Sifting Screen. Sifting screens of various sizes assist in the separation of a suspected item of evidence from the surrounding dirt and vegetation.

23.5.3.10 Global Positioning Satellite (GPS) Recorder. A GPS may be utilized to obtain the accurate longitudinal and latitudinal position of the fire origin. If necessary, this position can be cross referenced against on-site survey information, lightning strike data, aerial photography, or satellite imagery.

23.6 Security of the Area or Point of Origin. The area of origin should be secured and should not be untampered with prior to the investigation. Evidence should not be removed from the position in which it was found without documentation. If the area has been tampered with, it may mislead the investigation and affect evidence credibility.

23.6.1 Undisturbed Origin. The area of origin must remain as undisturbed as possible. Fire fighters, onlookers, and the property owner should stay out of this area. Fire fighters should enter this area only if it is necessary for fire operations. Vehicles should not be allowed to approach or move through the area because of the possibility of evidence being destroyed.

23.6.2 Investigation of Area of Origin. The investigator should conduct the examination of the origin area with minimum disturbance, seeking to expose the evidence of fire spread from the origin, rather than destroying or removing it during the investigation. A photographic record should be continued throughout the investigative process.

23.7 Fire Cause Determination. The objective of every origin and cause investigation is to establish the cause of the fire and to confirm this finding by identifying and, if possible, recovering the heat source or ignition device (*see Chapter 16*). If the fire was ignited intentionally, the ignition source may have been discarded nearby or removed from the scene.

23.7.1 Natural Fire Cause. Wildfires are not always started by the actions of people. Many are ignited by natural causes, such as lightning. Other examples of wildfire ignited by natural causes include volcanoes and spontaneous combustion.

23.7.1.1 Lightning. Lightning is a well-recognized cause of wildfires, particularly in forested areas, striking trees, power lines and rock outcrops. The action of the lightning strike in a tree can not only splinter the trunk, but can form glassy clumps, called *fulgurites*, by melting sand in the soil in the root area. Lightning may simply strike the ground, igniting nearby fuels. When lightning is suspected, a GPS may be used to gather data, which then can be provided to a lightning detection service for confirmation of that activity.

Lightning-caused fires may smolder undetected for as long as several days after a lightning strike before surfacing as an active wildfire.

23.7.1.2 Spontaneous Heating. Special types of fuel will ignite spontaneously from internal heating caused by biological and chemical action. This action is most likely to occur on warm, humid days in decomposing piles of organic material such as hay, grains, feeds, manure, sawdust, wood chip piles, and harvested, piled peat moss.

23.7.2 Human Fire Cause. Human-caused fires are a result of human action or omission and are classified as accidental or incendiary. Accidental fires involve all those for which the proven cause does not involve a deliberate human act to ignite or spread fire into an area where the fire should not be. The incendiary fire is one deliberately ignited under circumstances in which the person knows that the fire should not be ignited.

23.7.2.1 Campsite. Circles of rocks, or pits with a large amount of ash, or a pile of wood are good indicators of a campfire. Even camp areas that have burned completely leave evidence of their prior existence. Discarded food containers, metal tent stakes, or metal grommets from a tent may be found, indicating the possibility of a campfire.

23.7.2.2 Smoking. Discarded ignited smoking materials, such as cigarettes, cigars, pipe tobacco and matches, can start wildfires. However, any of these heat sources require several conditions in order to ignite vegetation. The fuel source must be dry, and fine or powdery, such as litter or punky wood. Fuel moisture needs to be below about 25 percent. The ash and filter (if present) of a cigarette butt or burned match may be identifiable at the point of origin.

23.7.2.3 Debris Burning. Fires occur at dumpsites as well as at residences from garbage and other debris set on fire. Often, these operations spread to the neighboring vegetation. Burn barrels or incinerators may be a consideration as a fire cause. In windy conditions, hot ash and debris can blow away from

the debris burn and start a fire some distance away. Witnesses often are the best way to confirm whether or not debris burning was the cause of the fire.

23.7.2.4 Sunlight and Glass Refraction. The sun's rays can be focused to a point of intense heat if concentrated by certain glass or shiny objects. This refraction process bends light rays, similar to that which occurs through a magnifying glass. The shiny, concave end of a metal can may focus sunlight, but its short focal distance makes the potential as a possible cause unlikely.

23.7.2.5 Incendiary. These fires are often set in more than one location, and in areas that are frequently traveled. Matches, fusees, and other ignition devices may be found in the area of origin. The firesetter may decide to use a time-delay ignition device. Items to look for include cigarettes, rope, rubber bands, candles, and wire. For further information on incendiary fires, see Chapter 19.

23.7.2.6 Prescribed Fire (Controlled Burn). A prescribed fire is a fire resulting from intentional ignition by a person or a naturally caused fire that is allowed to continue to burn according to approved plans to achieve resource-management objectives.

23.7.2.7 Machinery and Vehicles. Vehicles and power machinery can cause wildfires in countless ways, from operating failures, overheated equipment, burning carbon, fuel leaks and spills, and friction. Any power or motorized equipment that uses electricity or flammable products in its operation or that creates ignition temperatures in its operation is capable of starting a fire when being operated in or adjacent to combustible vegetation. This includes vehicles, powered portable and mobile machinery, harvesting and construction equipment, chain saws, grinding tools, and cutting torches. Defective or failed parts add to the fire potential through friction heating of bearing-worn brakes, "frozen" shafts, and abrasion.

23.7.2.8 Railroad. Wildfires are sometimes started along railroads. Occasionally, fire used to clear a right-of-way will escape. Locomotives and rolling stock can also cause trackside fires from exhaust carbon, hot brake metal, or overheated wheel bearings (hot box).

23.7.2.9 Juveniles. The carelessness of a child, coupled with the curiosity of fire, may lead to wildfires around residences, schools, playgrounds, campsites, and wooded areas. Matches, lighters, or other ignition devices may be found in the area of origin.

23.7.2.10 Fireworks. Fireworks provide means of ignition through sparks and flaming debris. Sparklers are a smaller hazard, but may ignite dry grass or other fuels. Most sparklers include a metal (wire) or wood core that may be found at or near the point of fire origin. The remains of fireworks or their packaging may be found near the area of origin. Also, some fireworks have the potential to create small indentations in the ground due to their explosive force.

23.7.3 Utilities. Public and private utilities often are present through wildfire areas and therefore provide a potential ignition source.

23.7.3.1 Electricity. Overhead power lines may cause wildfires when trees contact a conductor and ignite the branch or foliage involved. This contact usually leaves a brand on the portion of the tree that made contact and creates a pit or flash mark on the power conductor. After ignition, burning portions of the tree may fall to the ground and ignite ground litter. In addition to tree

contact, conductors may be blown against each other (phase to phase) during a windstorm, creating a hot metal globule that falls to the ground. Conductors and transformers may fail, starting the pole or other equipment on fire, and may drop flaming or hot material onto the ground. Underground conductors can be damaged by heavy equipment or digging operations, resulting in fire. Electric fences are likewise a source of energy resulting in ignition of combustible materials.

23.7.3.2 Oil and Gas. Oil- and gas-drilling activities in wildfire areas can cause a fire. Most of the hazardous activities associated with fire take place during the drilling operations. A number of these hazards have been discussed in the smoking, equipment use, and electric paragraphs. A well blowout and subsequent ignition may cause a wildfire to ensue. Depending on the minerals to be extracted, gas-fired equipment such as separators may be present at the well site after the drilling process has been completed. Likewise, the proximity of pipelines carrying gas or liquid fuel may provide sources of the initial fuel or may be a contributing factor to wildfire spread.

23.8 Evidence. The protection, preservation, collection, and documentation of evidence is similar for wildfire, structure, and vehicle fire investigations. See Chapter 14 for information and guidance.

23.9 Special Safety Considerations. Safety considerations vary from those present in structural fire investigation; however, the basic principles are universal. (*See Chapter 10.*)

23.9.1 Hazards. Safety is a major concern on all fires. Investigating wildfires carries its own specific hazards that must be considered while on the fire scene. The investigator should log in with the Incident Commander and should keep fire-fighting personnel aware of his or her location. The investigator must be aware of areas where the fire may still be burning, or where fire has been extinguished but could rekindle. An avenue of escape must always be present and continually evaluated as fire conditions change. A rekindle and availability of fuels, along with a change in the wind direction may create hazards as extreme as a crowning fire, which may block the previously planned escape path.

Underground burning in a smoldering stage can erupt into flaming combustion if the fire burns to the surface or if the top layer of soil is disturbed, exposing the heated fuel to air. This phenomenon most commonly occurs where there is heavy peat content in the soil, or in areas where large sawdust piles were left from logging or sawmill operations. These piles sometimes are placed in small gullies, creating a level ground surface. The sawdust or peat can continue to burn and decompose below grade, sometimes creating underground cavities. A fire investigator walking across this area could drop into this cavity, opening it to the ambient air, and allowing flaming combustion.

Other associated hazards are falling debris from charred, fire-weakened trees and limbs. Leaning against or putting weight on trees could cause them to topple or break. Even light winds may cause branches to break and fall to the ground. Additional hazards may be present in sloped terrain. Logs or rocks can be loosened from their lodged location as a result of the fire, from suppression operations, or from the actions of an investigator. When the root structure is destroyed by fire, the soil may begin to lose its stability, which in turn can cause slides that may injure the investigator or destroy evidence.

The weather can also cause or contribute to hazards. Rain can create slippery footing. Lightning may be a concern as well. During lightning conditions, the investigator should not

stand under trees, but rather move to open space, staying low without lying down.

23.9.2 Personal Protective Equipment. Protective clothing and safety equipment will vary depending on the circumstances. If investigating while the fire is still in progress in the investigator's immediate vicinity, the investigator will need to comply with applicable federal, state, provincial, or local requirements for personal protective equipment applicable to wildfire fighting.

Fire investigators in such situations should conform to NFPA 1977, *Standard on Protective Clothing and Equipment for Wildland Fire Fighting*, and appropriate sections of NFPA 1500, *Standard on Fire Department Occupational Safety and Health Program*. The types of equipment addressed in NFPA 1977 are head protection, hood, body protection, hand protection, foot protection, and eye protection. In addition, respiratory protection is necessary and will be dictated by the type of hazardous atmosphere encountered. This type of safety equipment is perhaps the most important but the most often overlooked. Respiratory protection in the nature of a filter mask is, however, likely to be required. There are numerous manufacturers of filter masks. A mask should be fitted to the wearer to assure an adequate seal.

When investigating at a scene where the fire has been completely extinguished, the investigator will still need to comply with any regulatory standards. Even in the absence of mandatory regulations, recognized industry standards ought to be followed for the investigator's own protection. (*See Chapter 10.*)

23.10 Sources of Information. Information sources can be found in Section B.11.

Chapter 24 Management of Major Investigations

24.1 Introduction. This chapter is principally concerned with the investigation of major fire and explosion incidents as a management function with an organizational and managerial perspective. Major fire management characteristics include the control of the scene, in which many interests participate simultaneously. These interests may include multiple public and private agencies and usually an investigation team for each interested party. A protocol should be developed to meet agency objectives. This chapter provides guidance for these purposes.

A major fire or explosion incident may include fatal fires, fires in high-rise buildings, incidents involving major damage to large complexes or multiple buildings, conflagrations involving a large monetary loss, or fires resulting in a large number of personal injuries. While major incidents are not always large in size or magnitude, they do tend to be more complex. As a result, the primary goals in such circumstances are to preserve the evidence and to preserve the interests of the different parties involved.

Thorough investigations do not just happen, but instead are the result of careful planning, organization, and the ability to anticipate problems before they arise. Prior to actually beginning the scene investigation, numerous events, facts, and circumstances should be identified and considered before decisions are made as to how the investigation will flow. (*See Chapter 12.*)

24.2 Understanding between the Parties. Interested parties should be allowed to participate in the investigation and examine the evidence in its undisturbed condition. No party should remove evidence or materials without adequate notice to other interested parties.

Different parties can conduct a joint investigation and still have separate and independent examinations. A joint investigation allows recording and examination of the scene as it is altered or examined or as evidence is collected. Allowing all interested parties an equal opportunity to establish the facts should eliminate future accusations of wrongdoing, such as altering the evidence or hiding facts. The parties should work together through coordination of the investigation. Personal interests should be subjugated to the truth.

Public officials conducting an investigation may have concerns about allowing other investigators to participate during a criminal investigation, but these concerns can be alleviated through proper planning and communication. Other investigators may be able to assist the public officials by providing their expertise, other experts, equipment, and personnel. The purpose of any investigation is to seek the facts.

24.3 Agreement between Parties. An understanding or agreement should be developed through a consensus of the interested parties prior to conducting the investigation. The agreement should cover the following issues, where appropriate:

- (1) Control and access to the site.
- (2) How and which information discovered during the investigation will be shared (such as through public agencies, interviews, or research).
- (3) Joint custody and examination of evidence, usually a requirement for all parties. Parties should be notified prior to destructive examination. A sign-in sheet should be required to gain access to the evidence.
- (4) The acquisition and processing of needed nonproprietary information from the parties through their identified representative.
- (5) Release of information to the public, which may be coordinated through one spokesperson, usually the public official.
- (6) A protocol for the scene examination and debris removal. This may require regular scheduled meetings to discuss the progress and the activities that are to be conducted. A person may be selected to chair the meetings and “lead” the scene examination.
- (7) The development of a “flow chart” to provide guidance for the general scope of the investigation.

Figure 24.3(a) is an example of a “Memorandum of Understanding,” an agreement for a joint investigation. It should be accompanied by Figure 24.3(b).

24.4 Organization of the Investigation. Each of the representative parties may develop a team, with its members conducting various aspects of their investigation. Interested parties may share the costs and services of specialized personnel such as evidence technicians, photographers, air quality people, safety coordinator, laborers, and so forth. Each of the teams should have a team leader who will participate in the “team leader committee.” Many functions of the “team” and “team leader committee” are similar in organization of their responsibilities. The team leader committee organizes the investigation as a whole and coordinates the access to the evidence and the scene.

24.5 Team Leader Committee. The team leader committee should coordinate access to the site through whoever has control of the scene. This may be the building owner, the insurance company, the public authorities, or the courts. The committee should hold regular meetings to discuss the status of the investigation and to obtain a consensus from the parties regarding actions to

be taken. It may be helpful for the committee to develop a flow chart or plan to manage the investigation. Changes in the plan should be discussed with the participants in the investigation, so the committee is aware of the changes and why the changes were made. Figure 24.3(b) is an example of a flow chart that could be used as a starting point in organizing an investigation.

A person should be selected to chair and organize the meetings. This person should have the responsibility to keep the meetings and the investigation moving, using the flow chart as a guide. The team leader may coordinate reports, documents, interviews, and so forth, and may write a report on his or her observations. In investigations with more than one interested party, the person selected usually has the same voting authority as the other investigators. The team leader should be an experienced fire investigator with the ability to identify problems that may be encountered by the team and to solicit solutions from the group. Often, the public official or whoever has control of the site may be the most likely person for this position.

FIGURE 24.3(a) Memorandum of understanding.

This Memorandum of Understanding relates to the investigation of the fire that occurred on July 1, 1998, at the Tall Building and Storage Facility, 1007 Main Ave., Any City, State, USA. It recognizes that a number of independent investigations are being conducted simultaneously and coincidentally and all with a common goal — to determine the origin and cause of the fire. All interested parties recognize that cooperation with one another will be beneficial to each party and will produce an efficient, quality outcome.

The parties agree to the following:

An origin and cause investigation is being conducted.

The investigation is being conducted by the Yourtown Fire Department, The Federal Fire Investigations, Payall Insurance Company, Any Storage Company, and the Tall Building Company.

All investigation procedures and the physical collection of the evidence will be coordinated through regular meetings. The evidence will be collected and stored in a location where access is monitored. No testing or examination of the evidence will be conducted until all parties are notified.

All requests for data of a nonproprietary nature from the Tall Building Company or tenants will be processed through their identified representatives. Nonproprietary information provided by any party will be shared by all parties if requested.

All releases of information regarding the origin and cause of the fire will be coordinated through the Yourtown Fire Department, and no predisclosure of information will be made by any party.

The protocol recognizes that to remove material or conduct testing will require the permission of the Yourtown Fire Department and the undersigned parties. The request should be in writing; however, verbal agreement followed by written request and approval of the parties will be acceptable when time frames are short.

Testing and examination protocol of materials associated with this investigation are as follows:

- (1) All parties agree as to who will perform each examination and each test.
- (2) All parties agree to allow any other party to observe each test.
- (3) All parties agree to return any material remaining after each test to the storage facility.

Attached is an investigation flow chart to provide guidance for the general scope of the investigation.

FIGURE 24.3(b) Investigation flow chart.

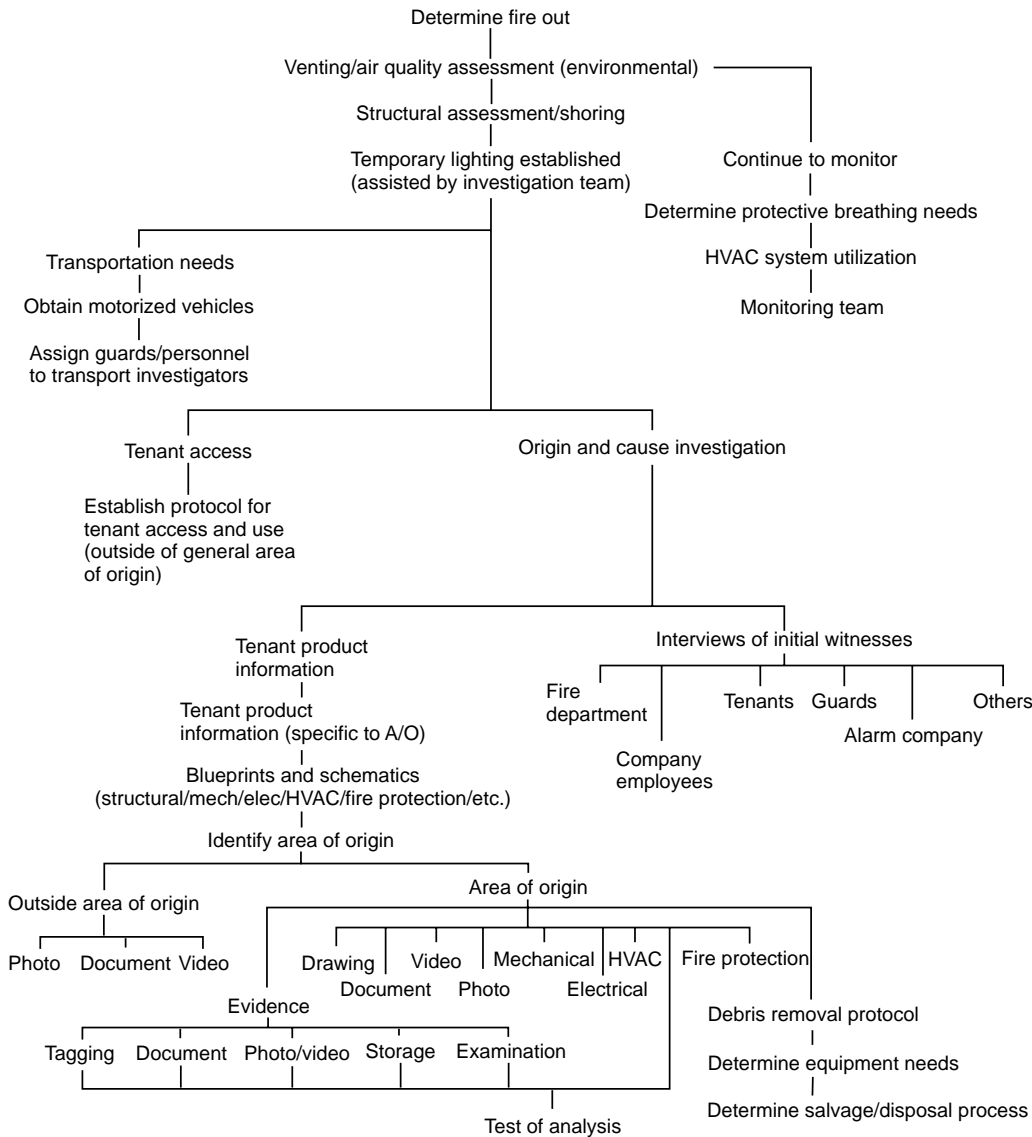

The person selected as team committee leader is generally one of the following:

- (1) Representative of an agency or department having responsibility to investigate the incident
- (2) Person selected by consensus of fellow team leaders
- (3) Representative of the private sector who has an interest in determining the origin and cause of the incident
- (4) Representative of the owner

It is recommended that the team select a secretary to take minutes of the meetings. Minutes should include the date, time, location, persons at the meeting, subjects discussed, and decisions reached. This record can be a tape recording with accompanying attachments.

A meeting should take place prior to an on-scene investigation. Personnel should be advised of the condition of the scene and the safety precautions required. Jurisdictional responsibilities and interests should be identified. Federal or state Occupational Safety and Health Administration (OSHA) compliance and safety concerns should be discussed.

Each of the interested parties should have one spokesperson at the meetings. Other representatives/investigators should be allowed to attend the meetings, but they should voice their concerns through their representative so that the meetings run efficiently.

It is reasonable to expect disputes, and efforts should be made to resolve these issues through proper planning, meetings, or other communications. Disputes concerning access to the scene, scene alterations, evidence collection, evidence preservation, and evidence disposition should be anticipated.

Some of the committee issues that need to be resolved may be as follows:

- (1) The purpose of the investigation
- (2) The expected role of the committee and teams
- (3) What agencies or parties are involved (e.g., local, state, federal, or private)
- (4) Identification of team members (e.g., identification cards, patch, or hats)
- (5) Number of persons from each party or agency
- (6) Control of entry to the scene

24.6 Planning. A plan, such as a systematic order for the tasks, should be developed to conduct the investigation. Changes in the plan or flow chart may be required as the investigation moves forward. The plan should have some flexibility. (See Chapter 12.)

24.7 Occupant Access. If possible, the investigation should be conducted in a manner that allows the occupants use of those portions of the facility not involved in the incident. This may require a delay in conducting some of the investigation until the situation can be stabilized for the occupants. Allowing the tenants/occupants to use space is important, but the fire or explosion scene should still be secured. This effort may help to lessen the interruption to business and the impact of the fire. Occupant access to any portions of the facility should be allowed only after the safety of the area has been established.

24.8* Organization of an Investigation Team. Organization of the team, with the members' responsibilities and duties, should be addressed. Some team members may have to assume/perform more than one function. The function should be identified in the flow chart or plan.

Responsibilities of an investigative team include the functions of air quality, structural safety, lighting, transportation, and safety. Some of these functions may be shared or organized with the other teams. The interested parties should share and organize the evidence removal and examination.

The team size, organization, and individual roles need to be addressed.

Having too many people at the scene may have a detrimental effect on the scene; likewise, too few may result in an incomplete or inefficient investigation. The number of individuals involved in the investigation depends on the size and complexity of the incident. Also, several responsibilities may fall to the same person.

A major loss team may include the following:

- (1) Leader
- (2) Secretary
- (3) Evidence technician
- (4) Photographer
- (5) Diagrammer
- (6) Interviewer
- (7) Searcher(s)

In addition, specialized personnel or skills should be used as necessary. (See Section 12.5.)

A successful major fire investigation requires proper management. One management system is known as the incident command system (ICS). ICS provides a management structure and system for on-site multidisciplinary operations.

24.9 Regular Meetings. The team leader committee should meet regularly to discuss the progress of the investigation, to discuss changes that may be required in the plan, and to inform the teams of what is going to happen and when. It is suggested that short meetings be held daily and that more thorough meetings be held weekly.

Each of the teams should also meet daily to coordinate their activities and to disseminate information to other team members. The regular team meetings provide the forum to share information developed by the team members, such as information from interviews, the scene examination, document research, and safety conditions.

24.10 Resources. The investigators responsible for major loss investigations should identify resources at their disposal from within their department or company, or from outside sources (e.g., pre-planning). Numerous fire investigators in rural areas

and small investigation departments have surmounted their resource deficiencies by locating additional resources of both manpower and material when pre-planning for major investigations. Unfortunately, the team concept, which can be utilized by both the public sector and the private sector, is often overlooked or disregarded because of budgetary constraints or because jurisdictional (i.e., turf) issues are allowed to take precedence over life safety and the need to conduct an organized investigation.

The investigator in charge at many incident scenes may be responsible for the entire investigation. A task force and team concept allow responsibilities to be delegated or conducted by more than one investigator.

24.11 Preliminary Information. The investigator should gain as much information as possible prior to developing the flow chart or plan (e.g., magnitude of the incident, the condition of the scene, information surrounding the incident, type of structure involved, use of the structure, and the nature and extent of damage). This information will allow the development of a plan that will address areas of importance to the investigation without requiring major modification.

24.12 Safety. Safety is the responsibility of all team members, but in some situations it may be necessary to designate one member as a safety monitor (i.e., safety officer) who will be responsible for monitoring conditions at the fire or explosion scene to ensure the safety of all personnel. The investigation plan should address safety not only for the investigators but for the tenants who will be utilizing the facility. The structure will need to be examined prior to conducting an investigation or removal of debris. Toxic gases or hazardous materials may have been present at the time of the incident or are there as a result of the fire.

It may be necessary to continue to monitor the air quality, environmental conditions, or structural stability while the investigation continues. The building's ventilation system should be evaluated for possible use in providing air quality. If the air or the environment cannot be rendered safe, the investigator(s) may be required to wear protective clothes and an appropriate filter mask or self-contained breathing apparatus.

Investigator fatigue can be a safety consideration in major fires and should be avoided. (See Chapter 10.)

24.13 Lighting. Temporary lighting may be required. It is often better to have electricians install temporary lighting than to use portable lights and flashlights for extended periods of time. The temporary lighting will allow the investigators to view the scene more easily. The need to install temporary lighting will be a function of current lighting conditions, the estimated time the investigation will take, and the availability of other lighting and electrical power.

24.14 Access for Investigator. Transportation may be needed to allow ease of movement of materials and investigators. There may be long distances to travel or it may be difficult to move equipment and personnel to the area. The fire area may be on higher floors that are difficult to reach. If these issues are addressed early, it will make the task much easier.

Golf carts or small motorized vehicles, boats, four-wheel-drive vehicles, helicopters, or other means of transportation may be needed to provide transportation to areas that are difficult to reach. An elevator in an adjoining building, fire department ground or aerial ladders, or a man lift may assist in reaching upper floors.

24.15 Securing the Scene. One of the first duties of the team is to secure the scene. First responders to the scene should establish and maintain control. Access should be monitored strictly, and all personnel should log on and off the scene.

Access should be restricted to authorized personnel both to facilitate the quality of the investigation and to prevent possible injury to unauthorized or curious onlookers.

The decision regarding authorization rests with whoever has control of the site.

It may be necessary to hire private security personnel or to install physical barriers to ensure the level of security needed.

24.16 Sanitary and Comfort Needs. Provisions should be made for sanitary facilities and drinking water. An uncontaminated area should be available for eating, resting, and meeting.

24.17 Communications. A large incident area may create communication problems for the investigators. Communication may be provided through either mobile or fixed means. Portable radios, temporary hardwired phone systems, or cellular telephones may be used. A command post using temporary trailers or other facilities may be needed to act as a central point.

24.18 Interviews. Upon arrival at the scene, the team leader should ensure that interviews are conducted with at least the preliminary witnesses. Examples of preliminary witnesses are the fire chief; fire prevention personnel; suppression personnel; police officers; passersby; neighbors; property owner(s); employees, tenants, or other people who may have information. The investigator should seek information on fire discovery, events prior to fire department arrival, fire suppression efforts, movement of the fire, and the building construction and contents. (*See Chapter 11 on interviewing.*)

Interviews can be conducted while other activities are being performed. It is usually better to subject a person to one thorough interview than to many interviews. If more than one party is participating in the investigation, a joint interview with a representative from each of the interested parties will usually result in a more thorough interview and will not subject the person to several interviews. It is best to have one person from each party participating in the interview rather than multiple investigators from each party. This will limit the interview team to a manageable number, and the team size won't overwhelm the person being interviewed.

Joint interviews will allow investigators to work off one another's thoughts and questions, and the interview will cover more details and topics. There will be times when joint interviews may not be practical, such as suspect interviews by public officials. Summaries of the interviews should be made to facilitate the briefing of other team members. Transcripts of statements of significance may need to be prepared as soon as possible.

24.19 Plans and Drawings. Copies of blueprints and schematics may be obtained for the facility. The plans will assist in tracing the electrical system, determining the capabilities of the HVAC system, and reviewing the fire protection/detection systems. Plans may assist in developing accurate drawings of the investigation and in locating or determining the operation of equipment. The plans may be obtained from the building owner, contractor, architect, or the public building department.

24.20 Recording the Scene. Recording the scene and the artifacts is required and is discussed in Chapter 13. Documentation includes photographs, videos, diagrams, and sketches.

24.21 Search Patterns. The personnel assigned to the physical examination of the scene should be the team members with experience and expertise in determining origin and cause of fire/explosion incidents. A grid system may be developed to conduct the investigation by dividing the scene into specific areas. The search in each grid is documented, and the evidence

from each grid is identified. The geometry of the scene may determine the grid system, such as by floor or by room.

Other methods include spiral, strip, or area searches. Regardless of the method used, the assigned search areas should overlap to ensure complete coverage.

24.22 Evidence. The removal of debris or evidence needs to be discussed with the interested parties/investigators prior to removal. The discussions may occur during the regularly scheduled meetings, through correspondence, at special meetings, or on the fire scene. The importance of reporting and properly securing evidence should be discussed with the team leader committee members.

One evidence technician should be selected to document the collection and preservation of all evidence. Evidence should be handled and secured as discussed in Chapter 14.

A protocol regarding the evidence collection, processing, and storage should address the type and location of the storage facility that is acceptable to the parties and the methods of handling the evidence. This often requires a secured location with a log-in sheet for persons accessing the area. All evidence collected should be equally accessible to all teams involved in the investigation. Prior to any destructive examination or testing, all teams should be notified. Each of the interested parties may decide to have its own expert view or participate in the examination.

24.23 Release of Information. The team should be discreet when matters concerning the incident are discussed around persons other than team members. One person or agency should be designated to release information through the team leader committee concerning the investigation. This person may be the public information officer or the fire marshal.

24.24 Conducting the Scene Examination. Conducting the scene examination is discussed in other chapters. The investigation techniques for major fires remain the same, but the scene typically is larger, requiring more interviews, more data, and more documentation.

24.25 Preplan for Major Fire Investigations. In many communities or private companies, the responsibility for determining the origin and cause of a major fire or explosion will be assigned to one or two investigators. The need to preplan the investigation remains constant.

This team or task force concept allows the investigation to proceed more rapidly and allows more time and resources to be spent on each task by assigning tasks to the investigators on the team.

Chapter 25 Referenced Publications

25.1 The following documents or portions thereof are referenced within this guide and should be considered as part of its recommendations. The edition indicated for each referenced document is the current edition as of the date of the NFPA issuance of this guide. Some of these documents might also be referenced in this guide for specific informational purposes and, therefore, are also listed in Appendix C.

25.1.1 NFPA Publications. National Fire Protection Association, 1 Batterymarch Park, P.O. Box 9101, Quincy, MA 02269-9101.

NFPA 54, *National Fuel Gas Code*, 1999 edition.

NFPA 58, *Liquefied Petroleum Gas Code*, 2001 edition.

NFPA 68, *Guide for Venting of Deflagrations*, 1998 edition.

NFPA 70, *National Electrical Code*[®], 1999 edition.

NFPA 72, *National Fire Alarm Code*[®], 1999 edition.
 NFPA 77, *Recommended Practice on Static Electricity*, 2000 edition.
 NFPA 121, *Standard on Fire Protection for Self-Propelled and Mobile Surface Mining Equipment*, 2001 edition.
 NFPA 220, *Standard on Types of Building Construction*, 1999 edition.
 NFPA 299, *Standard for Protection of Life and Property from Wildfire*, 1997 edition.
 NFPA 430, *Code for the Storage of Liquid and Solid Oxidizers*, 2000 edition.
 NFPA 1500, *Standard on Fire Department Occupational Safety and Health Program*, 1997 edition.
 NFPA 1971, *Standard on Protective Ensemble for Structural Fire Fighting*, 2000 edition.
 NFPA 1977, *Standard on Protective Clothing and Equipment for Wildland Fire Fighting*, 1998 edition.
 NFPA *Fire Protection Handbook*, 15th (1981), 16th (1986), 17th (1991), and 18th (1997) editions.
Fire Protection Guide to Hazardous Materials, 12th edition, 1997.
National Fuel Gas Code Handbook, 1996 edition.
 SFPE *Handbook of Fire Protection Engineering*. Society of Fire Protection Engineers, Quincy, MA, 1988 and 1995.
 SPP 51, *Flash Point Index of Trade Name Liquids*, 1978.

25.1.2 Other Publications.

25.1.2.1 ANSI Publications. American National Standards Institute, Inc., 11 West 42nd Street, 13th Floor, New York, NY 10036.

ANSI Z129.1, *Precautionary Labeling of Hazardous Industrial Chemicals*, 2000.
 ANSI Z400.1, *Material Safety Data Sheets — Preparation*, 1998.
 ANSI Z535.1, *Safety Color Code*, 1998.
 ANSI Z535.2, *Environmental and Facility Safety Signs*, 1998.
 ANSI Z535.3, *Criteria for Safety Symbols*, 1998.
 ANSI Z535.4, *Product Safety Signs and Labels*, 1998.
 ANSI Z535.5, *Accident Prevention Tags*, 1998.

25.1.2.2 API Publication. American Petroleum Institute, 1220 L Street, NW, Washington, DC 20005.

RP 2003, *Protection Against Ignitions Arising Out of Static, Lightning, and Stray Currents*, 1991.

25.1.2.3 ASTM Publications. American Society for Testing and Materials, 100 Barr Harbor Drive, West Conshohocken, PA 19428-2959.

ASTM D 56, *Standard Test Method for Flash Point by Tag Closed Tester*, 1993.

ASTM D 92, *Standard Test Method for Flash and Fire Points by Cleveland Open Cup*, 1996.

ASTM D 93, *Standard Test Method for Flash Point by Pensky-Martens Closed Cup Tester*, 1996.

ASTM D 1230, *Standard Test Method for Flammability of Apparel Textiles*, 1994.

ASTM D 1265, *Standard Practice for Sampling Liquefied Petroleum (LP) Gases (Manual Method)*, 1997.

ASTM D 1310, *Standard Test Method for Flash Point and Fire Point of Liquids by Tag Open-Cup Apparatus*, 1986.

ASTM D 1929, *Standard Test Method for Determining Ignition Temperature of Plastics*, 1996.

ASTM D 2382, *Standard Test Method for Heat of Combustion of Hydrocarbon Fuels by Bomb Calorimeter (High Precision Method)*, 1988.

ASTM D 2859, *Standard Test Method for Flammability of Finished Textile Floor Covering Materials*, 1993.

ASTM D 3065, *Standard Test Methods for Flammability of Aerosol Products*, 1994.

ASTM D 3659, *Standard Test Method for Flammability of Apparel Fabrics by Semi-Restraint Method*, 1980.

ASTM D 3828, *Standard Test Methods for Flash Point by Small Scale Closed Tester*, 1993.

ASTM D 5305, *Standard Test Method for Determination of Ethyl Mercaptan in LP-Gas Vapor*, 1997.

ASTM E 84, *Standard Test Method for Surface Burning Characteristics of Building Materials*, 1997.

ASTM E 108, *Standard Test Method for Fire Tests of Roof Coverings*, 1996.

ASTM E 119, *Standard Methods of Tests of Fire Endurance of Building Construction and Materials*, 2000.

ASTM E 603, *Standard Guide for Room Fire Experiments*, 1995.

ASTM E 648, *Standard Test Method for Critical Radiant Flux of Floor-Covering Systems Using a Radiant Heat Energy Source*, 1997.

ASTM E 659, *Standard Test Method for Autoignition Temperature of Liquid Chemicals*, 1978.

ASTM E 681, *Standard Test Method for Concentration Limits of Flammability of Chemicals*, 1994.

ASTM E 800, *Standard Guide for Measurement of Gases Present or Generated During Fires*, 1995.

ASTM E 860, *Standard Practice for Examining and Testing Items That Are or May Become Involved in Product Liability Litigation*, 1982.

ASTM E 906, *Standard Test Method for Heat and Visible Smoke Release Rates For Materials and Products*, 1997.

ASTM E 1188, *Standard Practice for Collection and Preservation of Information and Physical Items by a Technical Investigator*, 1995.

ASTM E 1226, *Test Method for Pressure and Rate of Pressure Rise for Combustible Dusts*, 1994.

ASTM E 1352, *Standard Test Method for Cigarette Ignition Resistance of Mock-up Upholstered Furniture Assemblies*, 1994.

ASTM E 1353, *Standard Test Methods for Cigarette Ignition Resistance of Components of Upholstered Furniture*, 1994.

ASTM E 1354, *Standard Test Method for Heat and Visible Smoke Release Rates for Materials and Products Using an Oxygen Consumption Calorimeter*, 1997.

ASTM E 1387, *Standard Test Method for Ignitable Liquid Residues in Extracts from Fire Debris Samples by Gas Chromatography*, 1995.

ASTM E 1459, *Standard Guide for Physical Evidence Labeling and Related Documentation*, 1998.

ASTM E 1618, *Standard Guide for Ignitable Liquid Residues in Extracts from Fire Debris Samples by Gas Chromatography–Mass Spectrometry*, 1994.

25.1.2.4 IAAI Publication. International Association of Arson Investigators, 300 S. Broadway, Suite 100, St. Louis, MO 63102.

Fire and Arson Investigator (quarterly journal).

25.1.2.5 UL Publication. Underwriters Laboratories Inc., 333 Pfingsten Road, Northbrook, IL 60062.

UL 263, *Standard for Safety Fire Tests of Building Construction and Materials*, 1996.

25.1.2.6 USFA Publication. U.S. Fire Administration, Emmitsburg, MD 21727.

“Minimum Standards on Structural Fire Fighting Protective Clothing and Equipment,” 1992.

25.1.2.7 U.S. Government Publications. U.S. Government Printing Office, Washington, DC 20402.

Title 49, *Code of Federal Regulations*, Part 3280, “Manufactured Home Construction and Safety Standards (HUD Standard.)”

Title 49, *Code of Federal Regulations*, Part 129.625, “Fire Related Human Behavior,” U.S. Fire Administration, 257, 1994.

Consumer Safety Act (15 USC, Sections 2051–2084, and Title 16, *Code of Federal Regulations*, Part 1000).

Hazardous Substances Act (15 USC, Section 1261 et seq., and Title 16, *Code of Federal Regulations*, Part 1500).

Title 29, *Code of Federal Regulations*, Part 1910, “Federal Hazards Communication Standard.”

Flammable Fabrics Act (15 USC, Sections 1191–1204 and Title 16, *Code of Federal Regulations*, Parts 1615, 1616, and 1630–1632).

Federal Food, Drug and Cosmetic Act (15 USC, Section 321 (m), and Title 21, *Code of Federal Regulations*, Part 600).

Federal Rules of Evidence as amended through 2000.

OSHA Regulations (Title 29, *Code of Federal Regulations*, Part 1910).

U.S. Senate Committee on Government Operations. *Chart of the Organization of Federal Executive Departments and Agencies*.

25.1.2.8 Other References.

Babrauskas, V., and J. Krasny. *Fire Behavior of Upholstered Furniture*, NBS Monograph 173. Washington, DC: National Bureau of Standards, November 1985.

Baumeister, T., E. A. Avallone, and T. Baumeister III. *Mark's Standard Handbook for Mechanical Engineers*, 8th edition. New York: McGraw-Hill, 1978.

Bennett, C. O., and J. E. Myers. *Momentum, Heat, and Mass Transfer*, 2nd ed. New York: McGraw-Hill Book Co., 1974.

Black's Law Dictionary, 6th ed., 1990.

Bull, J. P., and J. C. Lawrence. “Thermal Conditions to Produce Skin Burns.” *Fire and Materials* 3(2) (June 1979): 100–105.

Bustin, W. M., and W. G. Duket. *Electrostatic Hazards in Petroleum Industry*. Research Studio Press, July 1983.

Douglas, J. E., A. W. Burgess, A. G. Burgess, and R. K. Kessler. *Crime Classification Manual*. New York: Lexington Books, 1992.

Drysdale, D. *An Introduction to Fire Dynamics*. New York: John Wiley and Sons, 1985.

Fang, J. B., and J. N. Breese. “Fire Development in Residential Basement Rooms.” National Bureau of Standards (currently NISTJ), NBSIR 80-2120, Gaithersburg, MD, 1980.

Flick, E. W. *Industrial Solvents Handbook*, 4th edition. Park Ridge, NJ: Noyes Data Corp., 1991.

FMC Product Safety Sign and Label System.

Glick, K., and R. Gieck. *Engineering Formulas*. 1977.

Guide to Plastics. New York: McGraw-Hill, 1989.

Hagglund and Persson. *An Experimental Study of the Radiation from Wood Flames*, FOA Report C 4589-D6(A3). Stockholm: Forsvarerets Forskningsanstalt.

Hagglund and Persson. *The Heat Radiation from Petroleum Fires*, FOA Report C 20126-D6(A3). Stockholm: Forsvarerets Forskningsanstalt.

Hilado, C. J. *Flammability Handbook for Plastics*, 4th ed. Lancaster, PA: Technomic Publishing, 1990.

Kennedy, P., and J. Shanley. “USFA Fire Burn Pattern Tests — Program for the Study of Fire Patterns.” FA 178, 7/97, (Federal Emergency Management Agency, United States Fire Administration, Emmitsburg, MD, 1997).

Krasny, J. *Cigarette Ignition of Soft Furnishings — A Literature Review with Commentary*. Center for Fire Research. Washington, DC: National Bureau of Standards, June 1987.

Lawson, D. I. “Fire and the Atomic Bomb.” *Fire Research Bulletin*, No. 1, HMSO, London, 1954.

Lawson, D. I., and D. L. Simms, “The Ignition of Wood by Radiation.” *British Journal of Applied Physics*, 3, 1952, 288–292.

Lee, B. T. *Heat Release Rate Characteristics of Some Combustible Fuel Sources in Nuclear Power Plants*, NBSIR 85-3195. Washington, DC: National Bureau of Standards, 1985.

Lide, D. R., ed. *Handbook of Chemistry and Physics*, 71st ed. Boca Raton, FL: CRC Press, 1990–1991.

Putorti, A. J. Jr. (NIST), “Full Scale Room Burn Pattern Study,” NII Report 601-97, Publication #169 281, (National Institute of Justice, National Criminal Justice Reference Service, Washington, DC, 1997).

Mil-Std-202F, *Test Method for Electronic and Electrical Components*. “Method 301, Dielectric Withstand Voltage.” U.S. Department of Defense Military Test Standard, 1998.

Mil-Std-202F, *Test Method for Electronic and Electrical Components*. “Method 302, Insulation Resistance.”

Plastics Handbook. New York: McGraw-Hill, 1986–1987.

Restatement of the Law, Second Torts, 402A, American Law Institute, Philadelphia, PA.

Severy, D. M., D. M. Blaisdell, and J. F. Kerkhoff. *Automobile Collision Fires*, SAE, 741180. Society of Automotive Engineers, 1974.

Tan, S. H. “Flare System Design Simplified,” *Hydrocarbon Processing*, 1967, 172–176.

Wood, P. G. Fire Research Note #953, Building Research Establishment, Boreham Wood, UK, 1973.

UNOCAL Lub Oils and Greases Div.

Appendix A Explanatory Material

Appendix A is not a part of the recommendations of this NFPA document but is included for informational purposes only. This appendix contains explanatory material, numbered to correspond with the applicable text paragraphs.

A.1.3.6 Approved. The National Fire Protection Association does not approve, inspect, or certify any installations, procedures, equipment, or materials; nor does it approve or evaluate testing laboratories. In determining the acceptability of installations, procedures, equipment, or materials, the authority having jurisdiction may base acceptance on compliance with NFPA or other appropriate standards. In the absence of such standards, said authority may require evidence of proper installation, procedure, or use. The authority having jurisdiction may also refer to the listings or labeling practices of an organization that is concerned with product evaluations and is thus in a position to determine compliance with appropriate standards for the current production of listed items.

A.1.3.10 Arson. Precise legal definitions vary among jurisdictions, wherein it is defined by statutes and judicial decisions.

A.1.3.24 Code. The decision to designate a standard as a “code” is based on such factors as the size and scope of the document, its intended use and form of adoption, and whether it contains substantial enforcement and administrative provisions. There are other standards-making bodies that define the word *code* differently.

A.1.3.26 Combustible Gas Indicator. Some units may indicate the percentage of the lower explosive limit of the air–gas mixture.

A.1.3.48 Fire Dynamics. See sources in Section B.1.

A.1.3.52 Fire Science. See sources in Section B.2.

A.1.3.69 Guide. There are other standards-making bodies that define the word *guide* differently.

A.1.3.71 Heat. Heat is measured in joules, calories or Btus. Heat is not measured in °F or °C. The joule is the preferred unit. A joule/second is a watt. (See 1.3.132.)

A.1.3.73 Heat of Ignition. Heat energy comes in various forms and usually from a specific object or source. Therefore, the heat of ignition is divided into two parts: (a) equipment involved in ignition and (b) form of heat of ignition

A.1.3.74 Heat Release Rate (HRR). The heat release rate of a fuel is related to its chemistry, physical form, and availability of oxidant and is ordinarily expressed as Btu/s or kilowatts (kW).

A.1.3.88 Overload. A fault, such as a short circuit or ground fault, is not an overload. (See also 1.3.87.)

A.1.3.91 Plastic. Plastics are usually made from resins, polymers, cellulose derivatives, caseins, and proteins. The principal types are thermosetting and thermoplastic.

A.1.3.100 Recommended Practice. There are other standards-making bodies that define the term *recommended practice* differently.

A.1.3.115 Spontaneous Heating. The process results from oxidation, often aided by bacterial action where agricultural products are involved.

A.1.3.116 Standard. There are other standards-making bodies that define the word *standard* differently.

A.1.3.118 Temperature. The lowest possible temperature is absolute zero on the Kelvin temperature scale (-273° on the Celsius scale). At absolute zero it is impossible for a body to release any energy.

A.1.3.118.1 Absolute Temperature. The Celsius and Fahrenheit scales are relative scales that use “degrees.” The Kelvin and Rankine scales are absolute scales that do not utilize the term *degree*.

A.1.3.118.4 Ignition Temperature. Reported values are obtained under specific test conditions and may not reflect a measurement at the substance’s surface. Ignition by application of a pilot flame above the heated surface is referred to as pilot ignition temperature. Ignition without a pilot energy source has been referred to as autoignition temperature, self-ignition temperature, or spontaneous ignition temperature. The ignition temperature determined in a standard test is normally lower than the ignition temperature in an actual fire scenario.

A.1.3.120 Thermal Expansion. The amount of this increase per degree temperature, called the coefficient of thermal expansion, is different for different substances.

A.1.4 A complete list of conversion factors can be found in the NFPA *Fire Protection Handbook*, or in ASTM E 380, *Standard for Metric Practice*.

A.3.1.1.2 For more information on flammability limits, see USBM *Flammability Characteristics of Combustible Gases and Vapors*.

A.3.3 For additional information, see Ohlemiller, “Smoldering Combustion.”

A.3.5.4.1 For more information on room flashover, see Babrauskas, “Estimating Room Flashover Potential.”

A.3.5.5 Additional information on flame height can be found in *SFPE Handbook of Fire Protection Engineering*, Section I, Chapter 18.

A.4.2.2.1 For more information, see sources listed in Section B.3.

A.4.5.2 For more information, see Drysdale, *An Introduction to Fire Dynamics*.

A.4.6.1 For additional information, see Smith, “Concrete Spalling: Controlled Fire Tests and Review.”

A.4.12.1 Depth of calcination in gypsum wallboard is similar to depth of char in wood and many of the techniques are the same. See Sections 4.5 and B.4 for additional information.

A.4.13.1 For more information, see the following sources.

Skelly, *An Experimental Investigation of Glass Breakage in Compartment Fires*.

Lentini et al., “Baseline Characteristics of Residential Structures Which Have Burned to Completion: The Oakland Experience.”

For more information on pressures developed during fires, see Fang and Breese, *Fire Development in Basement Rooms*.

For more information on explosion and glass, see Harris, *The Investigation and Control of Gas Explosions in Buildings and Heating Plants*.

A.4.13.2 For more information, see Cooke and Ide, *Principles of Fire Investigation*.

A.4.14 For additional information on collapsed furniture springs, see Tobin and Monson, “Collapsed Springs in Arson Investigations: A Critical Metallurgical Evaluation.”

A.4.16.1.4 For more information on floor covering critical radiant flux, see NFPA 253, *Standard Method of Test for Critical Radiant Flux of Floor Covering Systems Using a Radiant Heat Energy Source*, Chapter 2, as well as the NFPA *Fire Protection Handbook*, 18th edition, Section 7, Chapter 3.

Also see Fang and Breese, *Fire Development in Basement Rooms*.

A.4.17 For further information see sources in Section B.5.

A.6.3.1 For more information, see NFPA 70, *National Electrical Code*, or the NFPA *National Electrical Code Handbook*.

A.6.7.4 See Figure 6.10.6.2(f) for a photograph of melted solidified aluminum conductor.

A.6.9.4.4 Additional information on arc tracking is found in Campbell, *Flashover Failures from Wet-Wire Arcing and Tracking*, and in Cahill and Dailey, *Aircraft Electrical Wet-Wire Arc Tracking*.

A.6.10.2 For more information, see Beland, “Considerations on Arcing as a Fire Cause,” and Beland, “Electrical Damages — Cause or Consequence?”

A.6.10.3 For more information, see Beland, “Considerations on Arcing as a Fire Cause,” and Beland, “Electrical Damages — Cause or Consequence?”

A.6.10.4 For more information, see Ettlting, “Glowing Connections.”

A.6.10.5 For more information, see Beland, “Examination of Electrical Conductors Following Fire.”

A.6.10.6.3 For more information, see Beland et al., “Copper-Aluminum Interactions in Fire Environments.”

A.6.10.6.4 For more information, see Ettlting, “Arc Marks and Gouges in Wires and Heating at Gouges.”

A.6.11.8 For more information, see Ettlting, “The Overdriven Staple as a Fire Cause,” and Ettlting, “Ignitability of PVC Electrical Insulation by Arcing.”

A.6.12.2.1 For more information on static in ignitable liquids, see API RP 2003, *Protection Against Ignitions Arising Out of Static, Lightning, and Stray Currents*.

A.6.12.2.3 For more information on switch loading, see 5.6.10, 1996 edition of NFPA 30, *Flammable and Combustible Liquids Code*; Appendix B of NFPA 385, *Standard for Tank Vehicles for Flammable and Combustible Liquids*; API RP 1004, *Bottom Loading and Vapor Recovery for MC-306 Tank Motor Vehicles*; and API RP 2013, *Cleaning Mobile Tanks in Flammable or Combustible Liquid Service*.

A.6.12.3 For more information, see NFPA 77, *Recommended Practice on Static Electricity*.

A.6.12.4 For more information, see NFPA 77, *Recommended Practice on Static Electricity*.

A.6.12.8 For additional information, see NFPA *Fire Protection Handbook*, Section 3, Chapter 5.

A.7.2 Further information on the properties of fuel gas can be found in the NFPA *Liquefied Petroleum Gases Handbook* and the NFPA *National Fuel Gas Code Handbook*.

A.7.3.1 For more information, see Title 49, *Code of Federal Regulations*, Part 178.

A.7.4.1.1 For more information, see ASME *Boiler and Pressure Vessel Code*.

A.7.4.1.2 For more information, see ASME *Boiler and Pressure Vessel Code*.

A.7.7.1.3 For more information, see U.S. Consumer Products Safety Commission Working Group on Gas Voluntary Standards, *Position Paper on Gas Water Heaters to Prevent Ignition of Flammable Vapors*.

A.7.8 For more information, see American Gas Association, *Gas Engineers Handbook*.

A.7.9.3.8 For more information, see Kennedy and Kennedy, *Explosion Investigation and Analysis*.

A.7.9.4.2 For more information, see NFPA *Liquefied Petroleum Gases Handbook*, and NFPA *National Fuel Gas Code Handbook*.

A.7.9.7 For more information, see American Gas Association, *Gas Engineers Handbook*.

A.7.9.7.1 See sources listed in Section B.6.

A.8.3.2.1 See Latine and Darley, *Journal of Person Soc. Psych.*

A.8.3.2.2 See Bryan, “A Study of the Survivor’s Reports on the Panic in the Fire at Arundel Park Hall, Brooklyn, Maryland, on January 29, 1956.”

A.8.3.3.4 For further information, see NFPA *Fire Protection Handbook*, 18th ed., Section 8, Ch. 1, by J. L. Bryan.

A.9.1 While many of the basic legal rules and concepts are similar in Canada, important differences also exist. An investigator should be cautious about applying the legal rules outlined in this chapter to investigations governed by Canadian law. For an explanation of the relevant Canadian legal, procedural, and evidentiary rules addressed in this chapter, see Hewitt, *Fire Loss Litigation in Canada: A Practical Guide*.

A.10.1 For additional information concerning safety requirements or training, see appropriate local, state, or federal occupational safety and health regulations and J. W. Munday, *Safety at Scenes of Fire and Related Incidents*.

A.11.1 For relevant forms that can be used to collect witness statements and insurance information and to track other records and documents relevant to the fire investigation, see NFPA 906, *Guide for Fire Incident Field Notes*, Form 906.6 (Witness Statement); Form 906.10 (Insurance Information); and Form 906.11 (Records/Documents).

A.12.6 For a relevant form that can be used to collect case supervision data, see NFPA 906, *Guide for Fire Incident Field Notes*, Form 906.0 (Case Supervision). This form will assist the investigator in keeping track of the progress of the investiga-

tion, including what has been done; what needs to be done; as well as assignments, dates, and other information that is pertinent to managing the case.

For additional information, see Icove et al., *Combatting Arson for Profit*.

A.13.1 For relevant forms that can be used to record the photographs taken and to sketch the scene, see NFPA 906, *Guide for Fire Incident Field Notes*, Form 906.8 (Photograph) and Form 906.9 (Sketch). NFPA 170, *Standard for Fire Safety Symbols*, provides symbols useful in diagramming a fire or explosion scene. Helpful information can also be found in Section 11, Chapter 14, “Formats for Fire Hazard Inspecting, Surveying, and Mapping,” of the NFPA *Fire Protection Handbook*.

A.13.4.4 Many references, such as NFPA 170, *Standard for Fire Safety Symbols*, are available that can be used for assistance.

A.13.6 Further information can be obtained by contacting specification organizations such as the Construction Specifications Institute (CSI), 601 Madison St., Alexandria, VA 22314-1791.

A.14.1 For relevant forms that can be used to document physical evidence, see NFPA 906, *Guide for Fire Incident Field Notes*, Form 906.1 (Fire); Forms 906.2a, 906.2b, and 906.2c (Structure Fire); Form 906.3 (Motor Vehicle); Form 906.4 (Wildland Fire); and Form 906.5 (Casualty).

A.14.3 For more information, see Smith, “Firefighters Role and Responsibility in Preserving the Fire Scene and Physical Evidence.”

A.14.4.2 For further information, see Massachusetts Chapter of International Association of Arson Investigators, *A Pocket Guide to Accelerant Evidence Collection*.

A.14.5.1 Guidance useful to the investigator is available in ASTM E 1188, *Standard Practice for Collection and Preservation of Information and Physical Items by a Technical Investigator*; ASTM E 1459, *Standard Guide for Physical Evidence Labeling and Related Documentation*; and ASTM E 860, *Standard Practice for Examining and Testing Items That Are or May Become Involved in Product Liability Litigation*.

A.14.5.3.4 For more information, see IAAI Forensic Science Committee, “Position on Comparison Samples.”

A.14.5.3.5 For more information, see Kurz et al., “Evaluation of Canines for Accelerant Detection at Fire Scenes”; DeHaan, “Canine Accelerant Detection Teams: Validation and Certification”; and Tindall and Lothridge, “An Evaluation of 42 Accelerant Detection Canine Teams.”

A.15.2.3 A detailed explanation of the process of creating the diagram can be found on pages 51–56 of “USFA Fire Burn Pattern Tests — Program for the Study of Fire Patterns.”

A.17.3.1 For more information on fault trees, see NFPA *Fire Protection Handbook*, 18th ed., pages 37–41; NFPA 550, *Guide to the Fire Safety Concepts Tree*, App. C; and Kimamoto and Henley, *Probabilistic Risk Assessment and Management for Engineers and Scientists*, Ch. 4.

A.17.4.6 For additional information on egress analysis, see Section B.7.

A.17.4.7 More extensive discussions of fire dynamics analyses and models are included in the NFPA *Fire Protection Handbook*, and the SFPE *Handbook of Fire Protection Engineering*.

A.17.5.2 Figure A.17.5.2 gives examples of forms that can be used in data collection for compartment fire modeling.

FIGURE A.17.5.2 Data collection sheet for compartment fire modeling.

EXAMPLE FORM FOR DATA FOR COMPARTMENT FIRE MODELING

Room Number _____ Use _____

Size (use diagrams if possible) _____ Wall/floor/ceiling _____

Construction

Length _____

Width _____

Height _____

Lining Materials (that represent over 10% of room lining)
(Include thickness, density, and other material characteristics if known)

Wall Material	Percentage of Walls or Area Involved
_____	_____
_____	_____
_____	_____

Ceiling Material

Floor or Floor Covering Material

Doors, Windows, and Other Openings [Enter all heights as distance above floor. If door sill is at floor, enter zero (0).]

Openings	to Top	to Sill	Width	Changes During Fire (How?) ¹
_____	_____	_____	_____	_____
_____	_____	_____	_____	_____
_____	_____	_____	_____	_____
_____	_____	_____	_____	_____
_____	_____	_____	_____	_____
_____	_____	_____	_____	_____

¹ For example: "Window broke at 10:33" or "Door was closed until opened by escaping occupant, then left open — Exit Time 10:30."

(Page 1 of 2)

FIGURE A.17.5.2 Continued

DATA FOR COMPARTMENT FIRE MODELING

Heating, Ventilation, and Air Conditioning (HVAC). Include air flows from HVAC systems. Give rates and positions of , supply and return or exhaust in this room. Also sizes and types of ducts/diffusers.

Tightness of Walls, Closed Windows, Door Fits, etc. (Unless fit is very loose, classify as tight, average, or loose. If fit is very loose, try to get size, number, and location of cracks, etc.)

Doors _____

Windows _____

Inside Walls _____

Exterior Walls _____

Fire History (List all significant events involving progress of the fire.)

Time (hard or soft)	Event
e.g. 1:10 am	sofa involved, flames 3 feet high
1:17 am	room flashover
1:19 am	large fire plume into hallway
1:23 am	smoke out of third floor window

Initial Fuel Item(s) Description

Description	Size	Material
e.g. sofa	full	polyurethane, with cotton upholstery

Suspected Ignitor (List ignitor if known with qualification on confidence.)

Ignitor: e.g. cigarette

Confidence: probable

- A.18.1** The references in Section B.8 are of value when considering additional technical information on explosions involving structures or vessels.
- A.18.2** For more information, see the NFPA *Fire Protection Handbook*, 18th ed., Section 1, Chapter 6.
- A.18.2.1** For more information on BLEVEs, see Walls, “Just What Is a BLEVE?” and Best and Walls “Hot Water Heater BLEVE in School Kills Seven.”
- A.18.2.3** For more information, see the NFPA *Fire Protection Handbook*, 18th ed., Section 1, Chapter 6.
- A.18.3.2** For more information, see Kennedy and Kennedy, *Explosion Investigation and Analysis*.
- A.18.7.3** Additional information may be found in Yallop, *Explosion Investigation*.
- A.18.8.1** For more information, see NFPA 77, *Recommended Practice on Static Electricity*.
- A.18.8.2.1** The following references provide additional information on flame speeds:
Harris, *The Investigation and Control of Gas Explosions in Buildings and Heating Plants*.
NFPA 68, *Guide for Venting of Deflagrations*.
- A.18.8.2.2** For more information, see the following publications:
Kennedy and Kennedy, *Fires and Explosions — Determining Cause and Origin*.
O’Loughlin and Yokomoto, “Computation of One-Dimensional Spread of Leaking Flammable Gas.”
Rabinkov, “The Distribution of Flammable Gas Concentrations in Rooms.”
- A.18.8.2.4** For more information, see the following publications:
Bartknecht, *Explosions — Course Prevention Protection*.
NFPA 68, *Guide for Venting of Deflagrations*.
Zalosh, “Explosion Protection.”
- A.18.8.2.5** For more information, see NFPA 68, *Guide for Venting of Deflagrations*.
- A.18.8.4** For more information, see Harris, *The Investigation and Control of Gas Explosions in Buildings and Heating Plants*.
- A.18.9.1** For more information, see Hertzberg and Cashdollar, “Domains of Flammability and Thermal Ignitibility for Pulverized Coals and Other Dusts: Particle Size Dependence and Microscopic Residue Analyses,” and USBM, *Explosibility and Ignitibility of Plastic Abrasive Media*.
- A.18.9.2** For more information, see USBM, *Pressure Development in Laboratory Dust Explosions*.
- A.18.9.4** For more information, see USBM, *Preventing Ignition of Dust Dispersion by Inerting*.
- A.18.12** For more information, see Institute of Makers of Explosives, *Glossary of Commercial Explosives Industry Terms*.
- A.18.17.3** For condensed phase explosives, a methodology such as that presented in U.S. Army, “Structures to Resist the Effects of Accidental Explosions,” can be used to estimate the amount and configuration of explosives necessary to cause the damage.
Far-field effects are associated with the explosion damage that results from the air blast fronts and flying fragments. A TNT energy equivalent of the exploding system can be deduced from projectile weight, distance, and resulting damage. More details can be found in National Fire Academy, *Fire Dynamics Course Guide/Reader, Unit 4 — Explosions*.
- A.19.2.4** See Carman, “High Temperature Accelerants, A Study of HTA Fires Reported in the United States and Canada Between January 1981 and August 1991.”
- A.19.4.1.1** For additional information, see Icove, *Incendiary Fire Analysis and Investigation*.
- A.19.4.8** See *Crime Classification Manual*, p. 165.
- A.19.4.8.2** See Sapp et al., “A Motive-Based Offender Analysis of Serial Arsonist,” pages 4 and 71.
The following are the numerical classifications for firesetting used by the *Crime Classification Manual*.
- Vandalism** (200)
 - Willful and malicious mischief (201)
 - Peer acceptance/group pressure (202)
 - and other — not classified further (209)
 - Excitement** (210)¹
 - Thrill seeking (211)
 - Attention seeking (212)
 - Recognition (213)
 - Sexual gratification or perversion (214)
 - Revenge** (220)
 - Personal retaliation (221)
 - Societal retaliation (222)
 - Institutional retaliation (223)
 - Group retaliation (224)
 - Intimidation (225)
 - Other (229)
 - Crime concealment** (230)
 - Murder (231)
 - Suicide (232)
 - Breaking and entering or burglary (233)
 - Embezzlement (234)
 - Larceny (235)
 - Destroying records or documents (236)
 - and other (239)
 - Profit** (240)
 - Fraud fires (241)
 - Fraud to collect insurance (241.01)
 - Fraud to liquidate property (241.02)
 - Fraud to dissolve a business (241.03)
 - Fraud to conceal a loss or liquidate inventory (241.04)
 - Employment (242)
 - Parcel/property clearance (243)
 - Competition (244)
 - Other (249)
 - Extremist** (250)
 - Terrorism (251)
 - Riot/civil disturbance (253)
- A.19.4.8.2.2** See DeHaan, *Kirk’s Fire Investigation*, page 400.
- A.19.4.8.2.3** See Sapp et al., *A Motive-Based Offender Analysis of Serial Arsonist*, pages 7–8, 28, 31, 38, 41. Also see DeHaan, *Kirk’s Fire Investigation*, page 402.
- A.19.4.8.2.4** See DeHaan, *Kirk’s Fire Investigation*, page 402.
- A.19.4.8.2.5** See DeHaan, *Kirk’s Fire Investigation*, pages 396–398.
- A.19.4.8.2.6** See DeHaan, *Kirk’s Fire Investigation*, page 403.
- A.20.3.5** For further information, see Spitz, *Spitz and Fisher’s Medicolegal Investigation of Death*, Ch. 2, Thermal Injuries.
- A.20.4.2** For more information, see Section B.9.

FIGURE A.20.7.1.4 Example of a poster reminding persons of the law requiring the reporting of burn injuries.

(Please Post)

REPORT ALL BURNS IMMEDIATELY!

It's the law!*

REPORT ALL BURN INJURIES IMMEDIATELY: 1-800-345-5811

NYS DEPARTMENT OF STATE OFFICE OF FIRE PREVENTION AND CONTROL
Burn Injury Report (File within 72 hours)

Print or Type

1) VICTIM'S NAME (Last, First, M.I.)		FOR OFFICE USE ONLY CONTROL #	
3) VICTIM'S ADDRESS (NUMBER, STREET)		2) DATE OF BIRTH	
CITY, TOWN, POST OFFICE	STATE	ZIP CODE	
4) ADDRESS WHERE BURN OCCURRED (Number, Street)		8) DEGREE(S) OF BURN(S) <input type="checkbox"/> 1st <input type="checkbox"/> 2nd <input type="checkbox"/> 3rd	
CITY, TOWN, POST OFFICE	STATE	ZIP CODE	
6) TIME OF INJURY HRS.	7) PERCENT BURNED %	10) INJURY SEVERITY (Place appropriate number in box) 1 MODERATE (treated and released) 2 SERIOUS (hospitalized) 3 LIFE THREATENING (deaths imminent and/or probable) 4 DEAD ON ARRIVAL	
6 <input type="checkbox"/> LEG 7 <input type="checkbox"/> FOOT <input type="checkbox"/> ARM <input type="checkbox"/> HAND			
appropriate number in box) stic, corrosive or irritating substance furnace, iron, steam exhaust pipe, etc.			

Call the NYS Office of Fire Prevention and Control
24-hour toll-free hotline:
1-800-345-5811

- 2nd and 3rd degree burns 5 PERCENT OR MORE S.B.A.
- Burns to the UPPER RESPIRATORY TRACT
- LARYNGEAL EDEMA due to inhalation of super-heated air
- Any burn which may result in death

*Section 265.28 of the New York State Penal Law

Department of State
Gail S. Shalfer, Secretary of State

STATE OF NEW YORK
Mario M. Cuomo, Governor

Office of Fire Prevention
and Control
Francis A. McGarry, State Fire Administrator

A.20.5.1 For more information, see Section B.10.

A.20.7.1.4 Posters are sometimes used to remind persons of the law requiring the reporting of burn injuries. A example is shown in Figure A.20.7.1.4.

A.21.5.1.1 For additional information on steel and the effect of fire on it, see Lentini et al., "Baseline Characteristics of Residential Structures Which Have Burned to Completion: The Oakland Experience."

For additional information on the alloying of metals during a fire, see Beland, "Electrical Damages — Cause or Conse-

quence?" and Beland et al., "Copper-Aluminum Interactions in Fire Environments."

A.22.3.1 For additional information, see API PUBL 2216, *Ignition Risk of Hydrocarbon Vapors by Hot Surfaces in the Open Air*.

A.22.4.2.3 For more information, see Severy et al., *Automobile Collision Fires*.

A.22.4.3 For more information, see Cole, *The Investigation of Motor Vehicle Fires: A Guide for Law Enforcement, Fire Department and Insurance Personnel*. See also API PUBL 2216, *Ignition Risk of Hydrocarbon Vapors by Hot Surfaces in the Open Air*.

A.22.4.4 For more information, see Severy et al., *Automobile Collision Fires*, and API PUBL 2216, *Ignition Risk of Hydrocarbon Vapors by Hot Surfaces in the Open Air*.

For more information on mechanical sparks as an ignition source, refer to Campbell, *Appraisal of the Hazards of Friction-Spark Ignition of Aircraft Crash Fires*, and API PUBL 2214, *Spark Ignition Properties of Hand Tools*.

A.22.5.1.2 For more information on fuel line siphoning, see SAE Paper 980561, “Automotive Fuel Line Siphoning,” by T. Green.

A.24.8 It might be appropriate to consider the Incident Command System (ICS) as a management tool for major fire investigations, since it is gaining such a wide use among public agencies with fire investigation responsibilities. Incident command information is available through NFPA, the Federal Emergency Management Agency/U.S. Fire Administration, state fire agencies, and many colleges.

Appendix B Bibliography

This appendix is not a part of the recommendations of this NFPA document but is included for informational purposes only.

B.1 Fire Dynamics. For sources on fire dynamics, see the following.

Drysdale, D. *An Introduction to Fire Dynamics*. 2nd ed., ch. 1, p. 1, middle of third paragraph, 1999.

Friedman, R. *Principles of Fire Protection Chemistry and Physics*, 3rd ed., ch. 6, p. 75, 1998.

B.2 Fire Science. For more information on fire science, see the following.

NFPA *Fire Protection Handbook*, 18th ed., Section 1, 1997.

Quintere, J. G. *Principles of Fire Behavior*. Delmar, 1997.

Drysdale, D. *An Introduction to Fire Dynamics*. 2nd ed., 1999.

Friedman, R. *Principles of Fire Protection Chemistry and Physics*, 3rd ed., 1998.

B.3 Effects of Room Ventilation on Pattern Magnitude and Location. See the following sources.

Kennedy, P., and J. Shanley. “Report on the United States Fire Administration (USFA) Program for the Study of Fire Patterns.” Proceedings, InterFlam 96, Interscience Ltd., London, 1966.

Shanley, J. “USFA Fire Burn Pattern Tests,” United States Fire Administration, Emmitsburg, MD, FA 178, 1997.

B.4 Calcination. See the following sources.

Kennedy, P., and J. Shanley. “Report on the United States Fire Administration (USFA) Program for the Study of Fire Patterns.” Proceedings, InterFlam 96, Interscience Ltd., London, 1966.

Shanley, J. “USFA Fire Burn Pattern Tests,” United States Fire Administration, Emmitsburg, MD, FA 178, July 1997.

B.5 Pattern Geometry. See the following sources.

Federal Emergency Management Agency. *USFA Fire Burn Pattern Tests*. U. S. Fire Administration (USFA), 16825 South Seton Ave., Emmitsburg, MD 21727.

Lawson, J. R. “An Evaluation of Fire Properties of Generic Gypsum Board Products.” NBSIR 77-1265, U. S. Department of Commerce, National Bureau of Standards, August, 1977.

Putorti, Anthony, J. Jr. (NIST), Full Scale Room Burn Pattern Study, NIJ Report 601-97, Publication #169 281, National Institute of Justice, National Criminal Justice Reference Service, Washington, DC, 1997.

B.6 Odorant Removal from Gas.

B.6.1 For a current discussion of gas odorization technology see the following.

The Gas Odorization Manual, American Gas Association, 1996. This is an updated version of the section on gas odorization in the *Gas Engineers Handbook*.

B.6.2 For a deeper understanding of gas odorization issues, see the following.

Wilson, G. G., and A. A. Attari. eds. *Odorization III*, Institute of Gas Technology, Chicago, IL (1993).

B.6.3 Also see the following.

Jacobus, O. J., and J. S. Roberts. “What Constitutes Adequate Odorization of Fuel Gases?” IGT Odorization Symposium 1995, IGT, 1995.

Andreen, B. H., and R. L. Kroencke. “Stability of Mercaptans Under Gas Distribution System Conditions.” *American Gas J.* 48 (5/65).

Andreen, B. H., and R. L. Kroencke. “Stability of Mercaptans Under Gas Distribution System Conditions.” Proc. Am. Gas Assoc., 136, 1964.

Campbell, I. D., N. A. Chambers, and O. J. Jacobus. “The Chemical Oxidation of Ethyl Mercaptan in Steel Vessels.” IGT Odorization Symposium 1994, IGT, 1994.

Campbell, I. D. “Factors Affecting Odorant Depletion in LPG.” Proc. Symp. on LP-Gas Odorization, 28, 1989.

Campbell, I. D. “Odorant Depletion in Portable Cylinders.” Proc. Symposium on LP-Gas Odorization, 1990.

Holmes, S. A., P. B. Van Benthuyzen, D. C. Lancaster, and M. A. Tiller. “Laboratory and Field Experience with Ethyl Mercaptan Odorant in Propane.” Proc. Symposium on LP-Gas Odorization, 1990.

Kopidlansky, R. “Odorant Conditioning of New Distribution Systems.” IGT Odorization Symposium 1995, IGT, 1995.

Sanders, R. “OSHA and DOT Odorization Regulations.” IGT Odorization Symposium 1995, IGT, 1995.

Johnson, J. L. “1965 Report on Project PB-48, Stability of Odorant Compounds.” Proc. 1966 AGA Distribution Conference, American Gas Association, 1966.

Johnson, S. J. “Ethyl Mercaptan Odorant Stability in Stored Liquid Propane.” Proc. Symposium on LP-Gas Odorization, 1989.

McHenry, W. B., and H. M. Faulconer. “Summary Report on Odorant Investigations.” Proc. Symp. on LP-Gas Odorization, 1, 1990.

Roberts, J. S., and D. W. Kelly, “Selection and Handling of Natural Gas Odorants.” In Wilson and Attari, eds. *Odorization III*, 29, IGT, 1993.

B.6.4 For testing LP-Gas by stain tubes and for sampling, see the following.

“Standard Test for Determination of Ethyl Mercaptan in LP-Gas Vapor.” ASTM Method D 5305-92, ASTM.

“Standard Method for Sampling Liquefied Petroleum (LP) Gases.” ASTM D 1265-82, ASTM.

B.6.5 For a current understanding of most LP odorization issues, see the following.

Proceedings of the Symposium of LP-Gas Odorization, 1989 and 1990. Copies may be available from the National Propane Gas Association or the Gas Processors Association.

B.6.6 For discussions of soil adsorption of odorants, see the following.

Nomura, K., and R. Organ. “Reaction of LP-Gas Odorants and Soils.” Proc. Symposium on LP-Gas Odorization, 76, 1990.

Parlman, R. M., and R. P. Williams. "Penetrabilities of Gas Odorant Compounds in Natural Soils." Proc. AGA Distribution Conference, 5/6/79.

Sullivan, F. "New Gas Odorants." In *Wilson and Attari, eds., Odorization III*. 209, IGT, 1993.

Tarman, P. B., and H. R. Linden. "Soil Adsorption of Odorant Compounds." IGT Research Bulletin #33, 7/1/61.

Williams, R. P. "Soil Penetrabilities of Natural Gas Odorants." *Pipeline & Gas J.* Mar, 1976.

B.7 Egress Analysis. See the following sources.

Bryan, J. L. *An Examination and Analysis of the Dynamics of Human Behavior in MGM Grand Hotel Fire*, NFPA, Quincy, 1983.

"Kentucky State Police Investigative Report to the Governor, Beverly Hills Supper Club Fire." Kentucky State Police, Frankfurt, 1977.

SFPE *Handbook of Fire Protection Engineering*, Section 3, Ch. 1, "Behavioral Response to Fire and Smoke," 2nd ed., 1995.

B.8 Explosions. For more information on explosions involving structures or vessels, see the following.

Baker, *Explosion Hazards and Evaluations*.

Baker and Tang, *Gas, Dust, and Hybrid Explosions*.

Bartknecht, *Dust Explosions*.

Bodurtha, *Industrial Explosion Prevention and Protection*.

Center for Chemical Process Safety, *Guidelines for Evaluating the Characteristics of Vapor Cloud Explosions, Flash Fires and BLEVEs*.

Chemical Propulsion Information Agency, *Hazards of Chemical Reactants and Propellants*.

Eckhoff, *Dust Explosions in the Process Industries*.

Gugan, *Unconfined Vapor Cloud Explosions*.

Harris, *The Investigation and Control of Gas Explosions in Buildings and Heating Plants*.

Nettleton, *Gaseous Detonations; Their Nature, Causes and Control*. NFPA 68, *Guide for Venting of Deflagrations*.

NFPA 69, *Standard on Explosion Prevention Systems*.

Prugh, "Quantitative Evaluation of 'BLEVE' Hazards."

Stull, *Fundamentals of Fire and Explosion*.

U. S. Army, "Structures to Resist the Effects of Accidental Explosions."

USBM, *Fire and Explosion Manual for Aircraft Accident Investigations*.

USBM, *Investigation of Fire and Explosion Accidents in the Chemical Mining and Fuel-Related Industries — A Manual*.

B.9 Victim Identification. For information on victim identification, see the following.

Ambach, E., W. Paaron, K. Zehethofer, and R. Scheithauer. *Sixth International Symposium on Human Identification*. Institute for Forensic Medicine, University of Innsbruck, Austria, 1995.

DiZinno, J., et al. "The Waco, Texas Incident: The Use of DNA Analysis to Identify Human Remains." *Fifth International Symposium on Human Identification*, 1994.

B.10 Carbon Monoxide. For information on carbon monoxide, see the following.

Gottuk, D. T., and R. J. Roby. "Effect of Combustion Conditions on Species Production," Section 2/Chapter 7, SFPE *Handbook of Fire Protection Engineering*, 2nd ed. Edited by P. J. DiNenno et al. NFPA, Quincy, MA, 1995.

Tewarson, A. "Generation of Heat and Chemical Compounds," Section 3, Ch. 4, SFPE *Handbook of Fire Protection Engineering*, 2nd ed. Edited by P. J. DiNenno et al. NFPA, Quincy, MA, 1995.

Purser, D. A. "Toxicity Assessment of Combustion Products," Section 2, Ch. 8, SFPE *Handbook of Fire Protection Engineering*, 2nd ed. Edited by P. J. DiNenno et al. NFPA, Quincy, MA, 1995.

Nelson, G. L. "Carbon Monoxide and Fire Toxicity: A Review and Analysis of Recent Work," *Fire Technology*, 34(1), 1998.

Hirschler, M. M., S. M. Debanne, J. B. Larsen, and G. L. Nelson, eds. *Carbon Monoxide and Human Lethality: Fire and Non-Fire Studies*. New York: Elsevier Applied Science, 1993.

Hall, J. R., and B. Harwood. "Smoke or Burns — Which Is Deadlier?" *NFPA Journal*, January/February 1995.

Gann, R. J., V. Babrauskas, and R. D. Peacock. "Fire Conditions for Smoke Toxicity Measurements." *Fire and Materials*, 18(3), May/June 1994.

DeHaan, J. "The Dynamics of Flash Fires Involving Flammable Hydrocarbon Liquids." *American Journal of Forensic Medicine and Pathology*, 7(1), 1996, 24-31.

DeHaan, J. D., Campbell, S. J., and Nurbaksh, S. "Combustion of Animal Fat and Its Implications for the Consumption of Human Bodies in Fires," *Science and Justice*, 39 (1), 1999, 27-38.

B.11 Wildfires. For sources on wildfires, see the following.

Ford, R. T. *Investigation of Wildfires*. Bend, OR: Maverick Publication, 1995.

International Fire Service Training Association. *Fundamentals of Wildland Firefighting*. 3rd ed. Stillwater, OK: IFSTA, 1998.

Teie, W. C. *Firefighters Handbook on Wildland Firefighting Strategy, Tactics & Safety*. Rescue, CA: Deer Valley Press, 1994.

Appendix C Referenced Publications

C.1 The following documents or portions thereof are referenced within this guide for informational purposes only and are thus not considered part of its recommendations. The edition indicated here for each reference is the current edition as of the date of the NFPA issuance of this guide.

C.1.1 NFPA Publications. National Fire Protection Association, 1 Batterymarch Park, P.O. Box 9101, Quincy, MA 02269-9101.

NFPA 30, *Flammable and Combustible Liquids Code*, 2000 edition.

NFPA 68, *Guide for Venting of Deflagrations*, 1998 edition.

NFPA 69, *Standard on Explosion Prevention Systems*, 1997 edition.

NFPA 70, *National Electrical Code*®, 1999 edition.

NFPA 77, *Recommended Practice on Static Electricity*, 2000 edition.

NFPA 170, *Standard for Fire Safety Symbols*, 1999 edition.

NFPA 253, *Standard Method of Test for Critical Radiant Flux of Floor Covering Systems Using a Radiant Heat Energy Source*, 2000 edition.

NFPA 385, *Standard for Tank Vehicles for Flammable and Combustible Liquids*, 2000 edition.

NFPA 550, *Guide to the Fire Safety Concepts Tree*, 1995 edition.

NFPA 906, *Guide for Fire Incident Field Notes*, 1998 edition.

Fire Protection Handbook, 15th (1981), 17th (1991), and 18th (1997) editions.

Liquefied Petroleum Gases Handbook, 2nd (1989) edition.

National Electrical Code Handbook, 1999.

National Fuel Gas Code Handbook, 1st (1988) edition.

SFPE *Handbook of Fire Protection Engineering*, 1995.

C.1.2 Other Publications.

C.1.2.1 API Publications. American Petroleum Institute, 1200 L Street, NW, Washington, DC 20005.

API PUBL 2214, *Spark Ignition Properties of Hand Tools*, 1989.

API PUBL 2216, *Ignition Risk of Hydrocarbon Vapors by Hot Surfaces in the Open Air*, 2nd edition, 1991.

API RP 1004, *Bottom Loading and Vapor Recovery for MC-306 Tank Motor Vehicles*, 1988.

API RP 2003, *Protection Against Ignitions Arising Out of Static, Lightning, and Stray Currents*, 1991.

API RP 2013, *Cleaning Mobile Tanks in Flammable or Combustible Liquid Service*, 1991.

C.1.2.2 ASME Publication. American Society of Mechanical Engineers, Three Park Avenue, New York, NY 10016-5990.

Boiler and Pressure Vessel Code, Section VIII, 1995.

C.1.2.3 ASTM Publications. American Society for Testing and Materials, 100 Barr Harbor Drive, West Conshohocken, PA 19428-2959.

ASTM S1-10, *IEEE Standard for Use of International System of Units (SI). The Modern Metric System*, 1991.

ASTM E 860, *Standard Practice for Examining and Testing Items That Are or May Become Involved in Product Liability Litigation*, 1997.

ASTM E 1188, *Standard Practice for Collection and Preservation of Information and Physical Items by a Technical Investigator*, 1995.

ASTM E 1459, *Standard Guide for Physical Evidence Labeling and Related Documentation*, 1992.

C.1.2.4 IAAI Publications. International Association of Arson Investigators, 300 S. Broadway, Suite 100, St. Louis, MO 63102.

A Pocket Guide to Accelerant Evidence Collection. Massachusetts Chapter, 1992.

IAAI Forensic Science Committee. "Position on Comparison Samples." *The Fire and Arson Investigator* 41, No. 2 (December 1990).

C.1.2.5 SAE Publication. Society of Automotive Engineers, 400 Commonwealth Drive, Warrendale, PA 15096.

SAE Paper 980561, "Automotive Fuel Line Siphoning," T. Green.

C.1.2.6 USBM Publications. U.S. Bureau of Mines, Columbia Plaza, 2401 E Street, NW, Washington, DC 20241.

Explosibility and Ignitibility of Plastic Abrasive Media. Internal Report No. 4657, K. Cashdollar and M. Hertzberg, June 1987.

Fire and Explosion Manual for Aircraft Accident Investigations, AD-771191, August 1973.

Flammability Characteristics of Combustible Gases and Vapors, Bulletin 627, M. G. Zabetakis, 1965.

Investigation of Fire and Explosion Accidents in the Chemical Mining and Fuel-Related Industries — A Manual, Report 680, Kuchta, 1985.

Pressure Development in Laboratory Dust Explosions.

Preventing Ignition of Dust Dispersion by Inerting, Report of Investigations 6543, 1964, p. 12.

C.1.2.7 USFA Publication. U.S. Fire Administration, Emmitsburg, MD 21727.

FA 178 Kennedy, P., and J. Shanley. "USFA Fire Burn Pattern Tests — Program for the Study of Fire Patterns." 7/97.

C.1.2.8 U.S. Government Publications. U.S. Government Printing Office, Washington, DC 20402.

Title 49, *Code of Federal Regulations*, part 178.

U.S. Army Technical Manual, TM 5-1300, Revision 1. "Structures to Resist the Effects of Accidental Explosions."

U.S. Consumer Products Safety Commission Working Group on Gas Voluntary Standards. *Position Paper on Gas Water Heaters to Prevent Ignition of Flammable Vapors*.

C.1.2.9 Other Publications.

American Gas Association. *Gas Engineers Handbook*. New York: Industrial Press, 1965.

Babrauskas, V. "Estimating Room Flashover Potential." *Fire Technology* 16, No. 2 (May 1980): 94–103.

Baker, W. E. *Explosion Hazards and Evaluations*. Amsterdam–New York: Elsevier Publishers, 1983.

Baker, W. E., and M. J. Tang. *Gas, Dust, and Hybrid Explosions*. Amsterdam–New York: Elsevier Publishers, 1991.

Bartknecht, W. *Dust Explosions*. Berlin–New York: Springer-Verlag, 1989.

Bartknecht, W. *Explosions — Course Prevention Protection*. New York: Springer-Verlag, 1980.

Beland, B. "Considerations on Arcing as a Fire Cause." *Fire Technology* 18, No. 2 (1982): 188–202.

Beland, B. "Electrical Damages — Cause or Consequence?" *Journal of Forensic Science* 29 (3) (July 1984): 747–761.

Beland, B. "Examination of Electrical Conductors Following Fire." *Fire Technology* 16, No. 4 (1980): 252–258.

Beland, B., C. Roy, and M. Tremblay. "Copper-Aluminum Interactions in Fire Environments." *Fire Technology* 19, No. 1 (February 1983): 22–30.

Best, R., and W. L. Walls. "Hot Water Heater BLEVE in School Kills Seven." *Fire Journal* 76, No. 5 (September 1982): 20–24 and 104–105.

Bodurtha, F. T. *Industrial Explosion Prevention and Protection*. New York: McGraw Hill, 1980.

Brannigan, F. L., *Building Construction for the Fire Service*, 3rd Ed., NFPA, 1992.

Bryan, J. L. "A Study of the Survivors' Reports on the Panic in the Fire at Arundel Park Hall, Brooklyn, Maryland, on January 29, 1956." Fire Protection Curriculum, University of Maryland, College Park, MD, 1957.

Cahill, P. L., and J. H. Dailey, U.S. Department of Transportation. *Aircraft Electrical Wet-Wire Arc Tracking*, DOT/FAA/CT-88/4. Washington, DC: Federal Aviation Administration, August 1988.

Campbell, F. J. *Flashover Failures from Wet-Wire Arcing and Tracking*. NRL Memorandum Report 5508. Washington, DC: Naval Research Laboratory, December 17, 1984.

Campbell, J. A., National Advisory Committee for Aeronautics. *Appraisal of the Hazards of Friction-Spark Ignition of Aircraft Crash Fires*, Technical Note 4024. Cleveland, OH: Lewis Flight Propulsion Laboratory, May 1957.

Carman, S. "High Temperature Accelerants, A Study of HTA Fires Reported in the United States and Canada Between January 1981 and August 1991," Sacramento, CA: U.S. Bureau of Alcohol, Tobacco and Firearms, October 1994.

Center for Chemical Process Safety. *Guidelines for Evaluating the Characteristics of Vapor Cloud Explosions, Flash Fires and BLEVEs*. Washington, DC: American Institute of Chemical Engineers, 1994.

Chemical Propulsion Information Agency. *Hazards of Chemical Reactants and Propellants*, CPIA 394, September 1984.

Cole, L. *The Investigation of Motor Vehicle Fires: A Guide for Law Enforcement, Fire Department and Insurance Personnel*, 3rd ed. Lee Books, 1992.

Cooke, R. A. and R. H. Ide. *Principles of Fire Investigation*. Institution of Fire Engineers, 1985, pp. 135–137.

DeHaan, J. "Canine Accelerant Detection Teams: Validation and Certification." *CAC News*, California Association of Criminalists, July 1994.

DeHaan, J. D. *Kirk's Fire Investigation*. 4th ed. Upper Saddle River, NJ: Brady/Prentice-Hall, Inc., 1997.

- Douglas, J. E., A. W. Burgess, A. G. Burgess, and R. K. Ressler. *Crime Classification Manual*. New York: Lexington Books, 1992.
- Drysdale, D. *An Introduction to Fire Dynamics*. New York: John Wiley and Sons, 1985.
- Eckhoff, R. K. *Dust Explosions in the Process Industries*. Butterworth-Heinemann, 1997.
- Ettling, B. "Ignitability of PVC Electrical Insulation by Arcing." *IAAI Oregon Chapter Newsletter* 1, No. 4 (March 1997).
- Ettling, B. "The Overdriven Staple as a Fire Cause." *Fire and Arson Investigator*, March 1994.
- Ettling, B. "Arc Marks and Gouges in Wires and Heating at Gouges." *Fire Technology* 17, No. 1 (1981): 61-68.
- Ettling, B. "Glowing Connections." *Fire Technology* 18, No. 4 (1982): 344-349.
- Fang, J., and N. Breese, National Bureau of Standards. *Fire Development in Basement Rooms*, NBSIR 80-2120. Washington, DC: U.S. Department of Commerce, October 1980.
- Gugan, K. *Unconfined Vapor Cloud Explosions*. Houston, TX: Gulf Publishing, 1978.
- Harris, R. J. *The Investigation and Control of Gas Explosions in Buildings and Heating Plants*. London and New York: E&FN Spon, Ltd., 1983.
- Hertzberg, M., and K. Cashdollar. "Domains of Flammability and Thermal Ignitibility for Pulverized Coals and Other Dusts; Particle Size Dependence and Microscopic Residue Analyses." *19th Symposium on Combustion*. Combustion Institute, 1982, pp. 1169-1180.
- Hewitt, T. D. *Fire Loss Litigation in Canada: A Practical Guide*. Toronto: Carswell, current edition.
- Icove, D. J. *Incendiary Fire Analysis and Investigation*. Open Learning Fire Science Program Course. Lexington, MA: Ginn Custom Publishing, 1983.
- Icove, D. J., V. B. Wherry, and J. D. Schroeder. *Combating Arson for Profit*. Columbus, OH: Battelle Press, 1980.
- Institute of Makers of Explosives. *Glossary of Commercial Explosives Industry Terms*. Safety Library Publications No. 12. Washington, DC, 1985.
- Kennedy, P., and J. Kennedy. *Explosion Investigation and Analysis*. Chicago, IL: Investigations Institute, 1990.
- Kennedy, J., and P. Kennedy. *Fires and Explosions — Determining Cause and Origin*. Chicago, IL: Investigations Institute, 1985.
- Kimamoto, H., and E. J. Henley. *Probabilistic Risk Assessment and Management for Engineers and Scientists*. IEEE Press, 1996.
- Kurz, M., et al. "Evaluation of Canines for Accelerant Detection at Fire Scenes." *Journal of Forensic Sciences* 39, No. 6 (November 1994): 1528-1536.
- Latine, R., and J. M. Darley. *J. Person Soc. Psych.* 10, 215, 1968.
- Lentini, J. J., D. M. Smith, and R. W. Henderson. "Baseline Characteristics of Residential Structures Which Have Burned to Completion: The Oakland Experience." *Fire Technology* 28, No. 3 (August 1992): 195-214.
- Munday, J. W. *Safety at Scenes of Fire and Related Incidents*. London: Fire Protection Association, 1994.
- National Fire Academy, Open Learning Fire Service Program. *Fire Dynamics Course Guide/Reader, Unit 4 — Explosions*. Emmitsburg, MD: National Emergency Training Center.
- Nettleton, M. A. *Gaseous Detonations; Their Nature, Causes and Control*. New York: Routledge, Chapman and Hall, 1987.
- Ohlemiller, T. J. "Smoldering Combustion." *SFPE Handbook of Fire Protection Engineering*. Quincy, MA: Society of Fire Protection Engineers, 1995, Section 2, Chapter 11.
- O'Loughlin, J. R., and C. F. Yokomoto. "Computation of One-Dimensional Spread of Leaking Flammable Gas." *Fire Technology* 25, No. 4 (November 1989): 308-316.
- Prugh, R. W. "Quantitative Evaluation of 'BLEVE' Hazards." *Journal of Fire Protection Engineering* 3, No. 1 (March 1981).
- Rabinkov, V. A. "The Distribution of Flammable Gas Concentrations in Rooms." *Fire Safety Journal* 13 (1988): 211-217.
- Sapp, A. D., T. G. Huff, G. P. Gary, and D. J. Icove. "A Motive-Based Offender Analysis of Serial Arsonist," Department of Justice/Federal Bureau of Investigation/Federal Emergency Management Agency.
- Severy, D. M., D. M. Blaisdell, and J. F. Kerkhoff. *Automobile Collision Fires*, SAE 741180, 1974.
- Skelly, M. J. *An Experimental Investigation of Glass Breakage in Compartment Fires*, NIST-GCR-90-578, 1990.
- Smith, D. W. "Firefighters Role and Responsibility in Preserving the Fire Scene and Physical Evidence." *The Times*, NFPA Fire Service Section (3), September 1995, p. 6.
- Smith, F. P. "Concrete Spalling: Controlled Fire Tests and Review." *Journal of Forensic Science* 31 (1991): 67-75.
- Spitz, W. U. *Spitz and Fisher's Medicolegal Investigation of Death*. 3rd ed. Springfield, IL: Charles C Thomas, 1993.
- Stull, D. R. *Fundamentals of Fire and Explosion*, AIChE Monograph Series No. 10, Vol. 73. New York: American Institute of Chemical Engineers, NY, 1977.
- Tindall, R., and K. Lothridge. "An Evaluation of 42 Accelerant Detection Canine Teams." *Journal of Forensic Sciences* 40, No. 4 (July 1995): 561-564.
- Title 49, *Code of Federal Regulations*, Part 178, "Specification for Packagings." Washington, DC: U.S. Government Printing Office.
- Tobin, W. A., and K. L. Monson. "Collapsed Springs in Arson Investigations: A Critical Metallurgical Evaluation." *Fire Technology* 25, No. 4 (November 1989): 317-335.
- Walls, W. J. "Just What Is a BLEVE?" *Fire Journal* 72, No. 6 (November 1978): 46-47.
- Yallop, J. *Explosion Investigation*. Harrogate, UK: Forensic Science Society Press, 1980.
- Zalosh, R. "Explosion Protection." *SFPE Handbook of Fire Protection Engineering*. Quincy, MA: Society of Fire Protection Engineers, 1995, Section 2, Chapter 5.

Index

©2001 National Fire Protection Association. All Rights Reserved.

The copyright in this index is separate and distinct from the copyright in the document that it indexes. The licensing provisions set forth for the document are not applicable to this index. This index may not be reproduced in whole or in part by any means without the express written permission of NFPA.

-A-

- Absolute temperature** *see* Temperature(s)
- Abstract and title companies** 11.6.8
- Accelerants**
- Absorbed by solid materials 14.5.3.2
 - Definition 1.3.1
 - Evidence of
 - Collection for testing 14.4.2, 14.5.3, 14.6.1, A.14.4.2
 - Floors and floor coverings 4.16.1.4, 4.17.7.2
 - Glass staining 4.13.3
 - Holes in/near floors 4.16.1.4
 - Irregular patterns 4.17.7.2, 4.17.8
 - Spalling 4.6, A.4.6.1
 - Surface appearance of char 4.5.5
 - Exotic 19.2.4, A.19.2.4
 - Liquid 4.6.1, 4.13.3, 14.5.3, 14.6.1, 19.2.2, 19.2.7.3, A.4.6.1
 - Solid 14.5.3.3 to 14.5.3.4, 14.6.1, A.14.5.3.4
 - Testing 14.5.3
- Access** *see* Entry
- Accident (definition)** 1.3.2
- Accidental fire cause** 16.2.1, 16.2.4 to 16.2.5, 16.5, 16.6.3
- Acetone** Table 3.3.4
- Acetylene** Table 3.3.4, Table 18.8
- Adhesives, tile** 4.16.1.4
- Adjuster, insurance** 12.5.8
- Administrative search warrant** 9.2.3.3
- Aerial fuels, wildland fires** 22.2.3
- Aerial photographs** 13.2.5.11
- Aerosol products, flammability of** 14.10.2.17
- Afterburners** 7.8(g), A.7.8
- Agreement between parties** 24.3
- Agriculture Department, U.S.** 11.5.4.1
- Air conditioners, window** 21.6.10
- Air drops** 23.3.8.2
- Air quality** 24.12; *see also* Atmospheres
- Air samples** 18.15
- Air supply, gas utilization equipment** 7.7.2
- Air-conditioning systems** *see* Heating, ventilating, and air conditioning (HVAC) systems
- Airflow** *see* Ventilation
- Alarms** 3.5.3.1, 8.3.3.4
- Alcohol** 3.6
- Alligator char** 4.5.5
- Alloying of metals** 4.8.2, 6.10.6.3, 21.5.1.1, A.6.10.6.3, A.21.5.1.1
- Alloys, metal** 19.2.3
- Alterations, site** 15.3.4
- Alternating current** 6.2.5 to 6.2.6, 6.3.2.1 to 6.3.2.2
- Aluminum** 6.9.5
- Alloying 4.8.2, 6.10.6.3, A.6.10.6.3
 - Appliance housings 21.5.1.1 to 21.5.1.2
 - Conductors/cables 6.2.12, 6.5, 6.7.1 to 6.7.2, 6.7.4, 6.9.2.1, 6.10.4 to 6.10.5, 6.10.6.2, A.6.10.4 to A.6.10.5
 - Dust Table 3.3.4
 - Melting temperatures Table 4.8
 - Sparks 22.4.4, A.22.4.4
- Ambient (definition)** 1.3.3
- Ambient temperatures** 3.3, 3.3.2, 6.2.11, 23.3.7.2
- American Society for Testing and Materials (ASTM)** 11.6.3
- Test methods 14.10.1 to 14.10.2, 14.10.4
- Ammonium nitrate fertilizer** 3.1.1.2
- Ampacity** 6.2.11
- Definition 1.3.4
- Amperes** 6.2.5, 6.2.11
- Calculation of total 6.2.16
 - Definition 1.3.5
- Anhydrous ammonia** Table 18.8
- Annealing, of springs** 4.14, A.4.14
- Apparel fabrics** 14.10.2.28
- Appliances** 15.4, Chap. 21, A.21.5.1.1
- Arson and 19.2.7.1, 19.3.2
 - Branch circuits 6.7
 - Cause analysis involving 16.3, 21.4
 - Collection as evidence 14.5.6
 - Components 21.5, A.21.5
 - Controls 7.7.3, 7.9.3.5
 - Cords 6.11.7, 21.5.2.1
 - Disassembly of 21.4.4
 - Examination and testing of 14.5.6, 14.10.4, 21.2.5, 21.4.5 to 21.4.6
 - Exemplar 21.4.5 to 21.4.6
 - Fire patterns 21.3.2, 21.4.1
 - Fuel gas 7.7 to 7.8, A.7.8
 - Gas 7.9.3.5
 - Housings 21.5.1, A.21.5.1
 - Origin analysis involving 21.3
 - Photographs of 13.2.5.7, 21.2.1 to 21.2.4, 21.4.4
 - Power sources 21.5.2
 - Pre-fire condition of 15.6.1
 - Reconstruction 21.2.5, 21.3.4
 - Residential 21.6
 - Scene recording 21.2
 - Switches 21.5.3
- Approved (definition)** 1.3.6, A.1.3.6
- Arc tracking** 6.9.4.4, A.4.9.4.4
- Arc welding** 6.9.4.3, 6.9.5
- Architectural drawings** 13.4.6
- Architectural schedules** 13.5
- Architectural specifications** 13.6, A.13.6
- Arcing through char** 6.10.3, A.6.10.3
- Definition 1.3.8
- Arcs** 6.9.4, A.6.9.4.4
- Appliance cords, damage to 21.5.2.1
 - Definition 1.3.7
 - Ground fault 6.10.2, A.6.10.2
 - High-voltage 6.9.4.1
 - Incendive 6.12.3, 6.12.7, A.6.12.3
 - Melting caused by 6.11.1
 - Motor vehicle fire ignition source 22.4.2.2, 22.5.3
 - Parting 6.9.4.3, 6.10.2, 6.11.8 to 6.11.9, A.6.10.2, A.6.11.4, A.6.11.8
 - Sparks from 6.9.5

Static 6.9.4.2, 6.12, A.6.12.3
 On surfaces of nonconductive materials 6.9.4.4, A.4.9.4.4

Area fire patterns 4.19

Area of origin *see* Origin

Areas of demarcation 4.3.1

Arrow patterns 4.3.4, 4.17.6
 Definition 1.3.9

Arson 8.6, 9.4.1, 16.2.3 to 16.2.5, Chap. 19, A.9.4.1.1, A.19;
see also Accelerants
 Analysis of 19.4.1, A.19.4.1
 Definition 1.3.10, 9.4.1, A.1.3.10
 Indicators 3.4, 14.3.4, 16.5, 19.2, A.19.2.4
 Noncombustion 19.3 to 19.4
 International Association of Arson Investigators 11.6.5
 Juvenile firesetters 8.5, 23.7.2.9
 Location of fire 19.3.1 to 19.3.2, 19.4.1.1
 Motive 19.4, 19.4.8, A.19.4
 Classification of 19.4.8.2, A.19.4.8.2
 Intent versus 19.4.8.1
 Motor vehicle fires 22.10
 Reporting 9.5
 Statutes 9.4.1.1, 9.5, A.9.4.1.1
 Timing of 19.4.1.2, 19.4.7
 Trailers 4.18.1 to 4.18.2, 14.3.4, 19.2.2
 Wildland fires 23.7.2.5

Arson immunity acts 9.5

Arson Information Management System (AIMS) 11.5.4.14

Artifacts 14.3.2 to 14.3.3, 14.3.4.1

Asbestos 10.2.7

Ash 3.6, 23.4.4.1

Assemblies, construction 5.4

Assessors, government 11.5.1.2, 11.5.2.3

ASTM *see* American Society for Testing and Materials (ASTM)

Atmospheres
 Fire scene 10.2.7
 Oxygen to initiate combustion in 3.1.1.2

Atomic absorption (AA) 14.10.2.4

Atomized liquids 3.3.2

Atriums 5.2.2

Attics 19.2.3

Attorney-client privilege 11.2.2

Attorneys 9.1, 9.2.2, 9.5, 12.5.7

Authority to conduct investigation 9.2.1

Auto Safety Hotline 22.7.3

Autoignition (definition) 1.3.75.1

Autoignition temperature *see* Temperature(s)

-B-

Backdraft (explosions) 18.2.4(4), 18.7.4, 18.10, Table 18.13.2
 Definition 1.3.12

Baled rags Table 3.3.5

Balloon frame construction 5.3.1.2

Bar holing 7.9.5.3

Barriers 4.2.1, 5.2.2.3, 5.3.1.1, 5.4.2

Basswood Table 3.3.1

Batteries
 Appliance 21.5.2.3
 Vehicle 22.3.2, 22.4.2, 22.5.3

Beads 6.10.3, 6.11.10, A.6.10.3
 Definition 1.3.13

Benchmark events 17.2

Bending, of steel beams/columns 4.9

Benzene Table 3.3, Table 3.3.4

Bibliography App. B

Biological terrorism 10.3.3

Black oxide 4.7

Black smoke 3.6

Blankets, electric 21.6.9

Blast focusing 18.5.2

Blast furnace gas Table 18.8

Blast pressure front 18.1, 18.2.3, 18.4.1, 18.5, 18.13.3.1
 Definition 1.3.14
 Injuries from 20.8.2.1
 Shape of 18.4.1.3

BLEVEs 18.2.2, 18.4.3, 18.6, 18.6.4, Table 18.13.2,
 18.17.5, A.18.2.1
 Definition 1.3.15

Blisters
 Char 4.5.5
 Definition 1.3.22
 Paint 18.8.2.2
 Varnish Fig. 4.19.2

Blood
 Injured patient, tests of 20.7.3.2
 Postmortem tests of 20.6.1

Blue-gray iron or steel 4.7, 21.5.1.1, A.21.5.1.1

Blueprints 24.19

Board of education, municipal 11.5.1.7

Body panels, vehicle 22.6

Boiler explosions 18.6.2

Bolts 3.2.1

Bomb calorimeter 14.10.2.12

Bombs 18.13.1.4, 19.2.7.1; *see also* Explosion(s); Explosives

Bonding, electrical 6.5, 6.12.5.2, 7.6.7

Bottoms of surfaces 4.17.7.1

Boxes, electrical 6.8.3

Brake systems, vehicle 22.5.7

Branch circuit breakers 6.6.2.2

Branch circuits 6.4, 6.7, 6.7.2
 Arcing in 6.9.5, 6.10.3, A.6.10.3
 Short circuits 6.11.9

Brass Table 4.8, 4.8.2, 6.10.4, 6.10.6.3, 21.5.1.3, A.6.10.6.3

Brewing grains Table 3.3.5

Brick 4.3.2, 4.6, Fig. 4.20.2

British thermal unit (Btu) 3.4
 Definition 1.3.16

Brittle wire 4.8.2

Bronze Table 4.8

Brush (wildland fuel) 22.2.3.4, 23.2.2.7, 23.3.5.2, 23.4.4

Building collapse 4.17.7.2

Building contents *see* Contents, building

Building departments, municipal 11.5.1.5, 15.9

Building loads 5.2.2.1

Building materials 5.2.3
 Attitude, position, and placement 5.2.3.7
 Flammability 5.2.3.2
 Ignitability 5.2.3.1
 Physical state and heat resistance 5.2.3.6
 Surface burning characteristics of 14.10.2.18
 Thermal conductivity 5.2.3.4
 Thermal inertia 5.2.3.3
 Toxicity 5.2.3.5

Building systems Chap. 5
 Construction assemblies 5.4
 Construction types 5.3

Design, construction, and structural elements,
effect on fire development of 5.2

Electrical 6.3 to 6.5, 24.19, A.6.3.1

Fuel gas Chap. 7, A.7

Burn injuries 4.3.5, 20.7.2

Antemortem 20.3.5 to 20.3.6

Arson 19.2.6

Body area 20.7.2.2

Degree of burn 20.7.2.1

Documentation 20.7.2.3

Explosions Table 18.13.3.1(a), 18.13.3.3

Mechanism of 20.7.2.4

Postmortem examination of 20.6.10

Burn patterns *see* Fire patterns

Burn time 4.5.5, 4.11

Burners, gas 7.5.4, 7.9.3.3

Burning

Height of 4.16.4

Intensity of 4.11

Burning rate *see* Heat release rate (HRR)

Burning velocity 18.8.2.1, A.18.8.2.1

Butane 7.2.3.1, Table 18.8, 18.15

Bystanders, safety of 10.2.6

-C-

Cables

Entry, arcing in 6.9.5

Meter and base, connection to 6.3.3

Overcurrent protection 6.3.4

Service drop/service lateral 6.3.2.1

Calcination 4.12, A.4.12.1

Bibliography B.4

Depth of

Analysis 4.12.3

Diagram 4.12.2

Measuring 4.12.4

Indications of 4.12.1, A.4.12.1

Calorie (definition) 1.3.18

Calorimeter 14.10.2.26

Cameras 13.2.2, 21.6.14

Campsites 23.7.2.1

Can openers, electric 21.6.4

Canada, legal considerations in A.9.1

Canada Department of Transport 22.7.3

Canadian Automobile Theft Bureau 22.7.1

Canadian Police Information Centre (CPIC) 22.7.1

Candles 19.2.7.1

Canine teams 12.5.9, 14.5.3, 14.5.3.5, A.14.5.3.5

Cans, for evidence collection 14.6.1

Carbon 3.6, 18.9

Carbon dioxide 3.1.1.1, 3.6, 20.5, A.20.5.1

Carbon monoxide 3.5.3.2, 3.6, 20.5, Table 18.8, 20.3.2, 20.5.1, 20.7.3.1.1, 20.7.3.2, 20.8.1, A.20.5.1, B.10

Carburetors 22.5.1.1

Cargo areas, vehicle 22.6.2, 22.7.4

Carpeting 4.2.4, 4.16.1.4, 4.17.7.2, 5.2.3.7, 14.10.2.16

Cartridge fuses 6.6.1.4

Cascade explosions *see* Explosion(s), Secondary

Case management 12.6, A.12.6

Cast iron Table 4.8

Casualties 4.3.5, Chap. 20, A.20

Arson 19.2.6

Cause of death 20.4.3

Death scene considerations 20.2

Documentation 13.2.5.9, 20.2.2

Fire suppression, effect of 20.2.1

Notification 20.2.3

Recovery of bodies and evidence 20.2.4

Death-related pathological and
toxicological examination 20.3, A.20.3.5

Explosions Table 18.13.3.1(a), 18.13.3.3

Injuries 20.7 to 20.8

Burns 20.7.2

Explosion-related 20.8.2

Inhalation 20.7.3, 20.8

Notification laws 20.7.1.4, A.20.7.1.4

Physical evidence 20.7.1, A.20.7.1.4

Seismic effect 20.8.2.4

Shrapnel 20.8.2.2

Thermal 20.8.2.3

Manner of death 20.4.4

Mechanism of death 20.5, A.20.5.1

Postmortem changes 20.4.6

Postmortem tests and documentation 20.3, 20.6, A.20.3.5

Remains identification 20.4.1

Victim activity prior to/during incident 20.4.5

Victim identification 20.4.2, A.20.4.2, B.9

Cause *see also* Explosion(s), Causes of

Appliances, analysis involving 21.4

Classification of cause 16.2

Definition 1.3.19

Determination Chap. 16

Arson 19.4.1, A.19.4.1

Certainty of opinions 16.2.5, 16.7

Explosion(s) *see* Explosion(s), Causes of

First material ignited 16.4

Ignition factor 16.5

Origin determination and 15.8

Responsibility, determining 16.6

Wildland fires 23.7

Explosion *see* Explosion(s), Causes of

Fire *see* Cause

Presumption of 2.3.6.1

Proximate or legal 9.6.1

CD players 21.6.14

Ceiling assemblies 5.4.1

Ceiling height 3.5.3.1, 3.5.4.2, 5.2.2.2, 17.6.1

Ceiling layer 3.5.3.1 to 3.5.3.2, 3.5.4.2 to 3.5.4.3

Definition 1.3.20

Ceiling layers 5.2.2, 5.2.2.2

Ceilings 17.6.1 to 17.6.2

Damage inside 4.16.1.3

Design of 5.2.2

Effect on fire of 3.5.3, 3.5.4.2

Finish rating 4.16.1.3

Fire patterns on 4.16.1

Ceramic

Appliance housings 21.5.1.7

Tiles 3.6

Chain of custody, for evidence 9.3.2.1, 14.9

Chairs, heat release rates of Table 3.4

Char 4.5

Arcing through *see* Arcing through char

Blisters	4.5.5	Protective	<i>see</i> Protective clothing and equipment
Definition	1.3.22	Static electricity and	6.12.2.8
Definition	1.3.21	Coal dust	Table 3.3.4
Depth of	4.5.3	Coast Guard, U.S.	11.5.4.9
Analysis	4.5.3.2	Codes	
Circular patterns	4.17.7.1	Compliance to	7.9.2
Diagram	4.5.3.1, 15.2.4	Definition	1.3.24, A.1.3.24
Fire duration and	4.5.5	Violations of	8.4.4, 9.6.2, 19.4.4
With fuel gases	4.5.4	Coffee makers	21.6.2
Measuring	4.5.3.3, 15.2.4	Coke oven gas	Table 18.8
Doors	4.2.2, A.4.2.2.1	Collection of evidence	2.4.4, 14.4.2, 14.5, A.14.4.2, A.14.5.1
Explosion evidence	15.5.4	Comparison samples	14.5.3.4, A.14.5.3.4
Fire duration and	4.5.5	Explosion scene	18.13.1.2 to 18.13.1.3, 18.13.3.3
Furniture	4.2.4, 4.14	Color changes	4.3.2, 4.7
Gypsum wallboard	4.12, A.4.12.1	Conductors	6.10.6.1
Interpretations of	4.5.5	Gypsum wall surfaces	4.12
Oxidation and	3.3, 3.3.5, 4.7	Color of smoke	3.6, 4.10
Rate of charring	4.5.2, A.4.5.2	Combustible (definition)	1.3.25
Tree trunk	23.4.5.1	Combustible gas indicator	4.17.7.2
Wood	4.5.1, 23.4.5.1	Definition	1.3.26, A.1.3.26
Wooden structural elements	4.16.1.3, 4.17.6	Combustible liquids	<i>see</i> Liquids
Charcoal	Table 3.3.5	Combustion	3.1.1.1
Chemical analysis	18.15	Chemistry of	3.1
Chemical chain reaction, uninhibited	3.1.1.4	Glowing	3.3, A.3.3
Chemical engineers	12.5.4	Heat of	<i>see</i> Heat, Of combustion
Chemical explosions	18.2.3, 18.4.3, A.18.2.3	Self-sustained	3.1.1.4
Chemical oxidizers	3.1.1.2	Of surface areas	4.3.2
Chemicals		Combustion explosions	18.2.4, 18.4.3
Autoignition temperature of	14.10.2.11	Combustion products	3.6
At fire scene	10.2.7, 10.3.2	Definition	1.3.27
Flammability limits	14.10.2.22	Commerce Department, U.S.	11.5.4.2
Chemistry of combustion	3.1	Communications, fire scene	24.17
Chemists	12.5.4	Comparative testing	14.10.4
Children and fire	8.5, 23.7.2.9	Compartment fires	3.1.1.2, 3.5.3, 5.2.2
Chlorine	3.1.1.2	Flashover and	3.5.3.2
Christmas trees	Table 3.4	Location of fire in	3.5.4.3
Chromium	Table 4.8	Ventilation generated smoke patterns	4.2.2, A.4.2.2.1
Cigarettes, as ignition source	Table 3.3	Compartmentation	5.2.2, 5.2.2.3
Arson	19.2.7.1	Complexity of incident	12.2.4;
Carpeting, ignition-resistant	4.16.1.4	<i>see also</i> Major fire investigations, management of	
Furniture, ignition-resistant	14.10.2.14 to 14.10.2.15	Computers	
Motor vehicle fires	22.4.5	Fire models	15.7.4, 17.4, 17.6, A.17.4.6 to A.17.4.7
Wildland fires	23.7.2.2	Personal	21.6.14
Circuit breakers	6.4, 6.6, 21.5.2.4, 21.5.3.2.1	Photograph presentations	13.2.2.3, 13.2.7.3
Branch	6.6.2.2	Sources of information	11.3.3 to 11.3.4, 11.5.4.14
Ground fault circuit interrupter	6.6.2.3	Concealed spaces	5.2.2.4, 5.4.4
Main breakers	6.6.2.1	Concrete	Table 3.2.1
Circular patterns	4.17.7 to 4.17.8	Accelerants on	14.5.3.2
Civil litigation	9.6, 9.7.2, 14.11	Construction	5.3.4.2
Civil unrest	19.4.7.2, 19.4.8.2.6	Spalling of	4.2.2, 4.6, A.4.6.1
Classification, fire cause	16.2	Conduction	3.2.1, 3.3
Clean burn	4.7, 4.11	Burns caused by	20.7.2.4
Definition	1.3.23	Definition	1.3.28
Cleaners, use of	14.4.2	Heat shadowing and	4.15.1
Clerks, government	11.5.1.1, 11.5.2.2	Conductors	
Cleveland open cup	14.10.2.7	Alloying	6.10.6.3, A.6.10.6.3
Closets	19.2.3	Ampacity of	6.2.11
Clothes dryers	21.6.13	Branch circuits	<i>see</i> Branch circuits
Clothes irons	21.6.12	Conductivity of conductor materials	6.2.12, 6.7.1 to 6.7.4
Clothing		Evidence of damage to, collecting	6.11.6
Of fire victim	20.6.8, 20.7.1.1	Fire damage (non-electrical)	6.10.6, A.6.10.6

- Fire-melted 6.10.2 to 6.10.5, 6.10.6.2, A.6.10.2 to A.6.10.5
- Grounded *see* Grounded conductors
- Grounding 6.3.2.1, 6.5, 6.7
- Insulation 6.7.5, 6.11.7
- Mechanical gouges in 6.10.6.4, A.6.10.6.4
- Melting of 6.11, A.6.11.8
- Arcing, caused by 6.11.1
- Fire, caused by 6.11.2
- Nicked or stretched 6.11.5
- Offsets 6.10.5, A.6.10.5
- Overcurrent *see* Overcurrent
- Overdriven staples in 6.11.8, A.6.11.8
- Overload *see* Overload
- Service 6.10.3, A.6.10.3
- Phase 6.3.2.2
- Single-phase 6.3.2.1
- Sizes 6.2.10, 6.7.2, 6.9.2.1
- Stranded 6.10.2, 6.10.6.2, 21.5.2.1, A.6.10.2
- Surface colors 6.10.6.1
- Undersized 6.11.4
- Ungrounded 6.3.2.1, 6.5, 6.7, 6.9.5, 6.10.2, 6.11.8, A.6.10.2
- As wildland fire ignition source 23.7.3.1
- Cone patterns**
- Inverted 4.17.2
- Truncated 4.2.2.1, 4.9, 4.17.5, A.4.2.2.1
- Confidential communications** 11.2.3
- Configuration of fuel** 16.4
- Confined fires** 3.5.3
- Confined fuel gas and liquid vapor** 18.6.3
- Coniferous litter** 23.2.2.3
- Connections**
- Heating 6.11.4
- Overheating 6.10.4, A.6.10.4
- Poor 6.9.2.3
- Consent, to property entry** 9.2.3.1
- Constitutional considerations, for evidence** 9.3.4
- Construction** *see also* Design, building
- Alternative residential 5.3.1.6.1
- Assemblies 5.4
- Concrete or masonry 5.3.4.2
- Explosion damage, effect on 5.2.6
- Fire development and 5.2
- Materials 5.2.3
- Metal 5.3.4.1
- Mill 5.3.3
- Noncombustible 5.3.4
- Ordinary 5.3.2
- Steel framed 5.3.1.6.3
- Types of 5.3
- Consultants, technical** 12.5
- Consumer electronics** 21.6.14
- Containers**
- Evidence *see* Evidence containers
- LP-Gas 7.4.1 to 7.4.3, A.7.4.1
- Containment, at fire scene** 12.2.5
- Containment vessel** 18.1, 18.5, 18.8.2.4 to 18.8.2.5, A.18.1, A.18.8.2.4
- Venting 18.4.1.3, 18.8.2.6
- Contamination**
- Of evidence 14.4, 14.5.3.1, A.14.4.2
- At fire scene 12.2.5
- Contents, building**
- Analysis of 15.7.3, 15.9, 17.6.2, 18.13.3.3
- Displacement 15.7.3
- Fire patterns 4.16.3, 15.7.3
- Removal by fire crew 15.7.2
- Removal or replacement as arson indicator 19.3.3
- Controlled burn** 23.7.2.6
- Convection** 3.2.2, 3.3, 3.3.1, 3.5.3.1, 4.2.2, 5.2.2
- Definition 1.3.29
- Heat shadowing and 4.15.1
- Cooking equipment** 7.8(c), 21.6.1, A.7.8
- Cooling systems** *see also* Heating, ventilating, and air-conditioning (HVAC) systems
- Fuel gas utilization system 7.8(d), A.7.8
- Vehicle 22.5.4.2 to 22.5.4.3
- Copper** Table 3.2.1, Table 4.8; *see also* Copper conductors
- Alloying 4.8.2, 6.10.6.3, A.6.10.6.3
- Arcing 6.9.5, 6.10.2, A.6.10.2
- Oxidation 4.7
- Copper conductors** 6.2.12, 6.5, 6.7.1 to 6.7.3, 6.9.2.1, 6.10.2, 6.10.5, A.6.10.2, A.6.10.5
- Copper-clad aluminum 6.7.4.1
- Fire-melted 6.10.6.2
- Insulation, color changes in 6.10.6.1
- Overheating connections 6.10.4, A.6.10.4
- Stretching of 6.11.5
- Copper-nickel alloy** Table 3.3
- Cords, electrical power** 6.11.7, 21.5.2.1, 22.4.2.4
- Corner effect** 3.5.4.3
- Corners, burning of** 3.3.1
- Coroner/medical examiner** 11.5.2.5, 20.2.3
- Corridors** 19.2.3
- Corrosion, fuel gas pipe** 7.9.3.7
- Cotton chairs** Table 3.4
- Cotton mattresses** Table 3.4
- County government** 11.5.2
- Crawl spaces** 19.2.3
- Crazing of glass** 4.13.1, A.4.13.1
- Crime concealment, arson for** 19.4.2, 19.4.8.2.4, 22.10
- Criminal acts, fire resulting from** 10.3; *see also* Arson
- Criminal investigation, death scene** 20.2.3
- Criminal prosecution** 9.4, 14.11, A.9.4.1.1; *see also* Arson
- Criminal search warrant** 9.2.3.4
- Critical radiant flux** 14.10.2.20, A.4.16.1.4
- Crowd photographs** 13.2.5.2
- Crown fuels** 23.2.3.1, 23.3.5.5, 23.4.5.2
- Cupping, wildland fires** 23.4.4.2
- Currents (definition)** 1.3.30
- Custodial setting** 9.3.4
- Cylinders, LP-Gas** 7.4.1 to 7.4.3, A.7.4.1
- D-**
- Damage**
- Arson 19.2.8, 19.3.5
- Assessment 11.5.5, 12.2.6, 15.2, A.15.2.3
- Explosion 18.8.2, 18.13.3.1, A.18.8.2
- Characterization of 18.3, A.18.3.2
- Pattern analysis 18.17.2
- Negligence, loss due to 9.6.1
- Wildland fires 23.4.2
- Danger, perception of** 8.8.1
- Data collection and analysis** 2.3.3 to 2.3.4
- Date, of incident** 12.2.2

- Dead loads** 5.2.2.1
- Deaths** *see* Casualties
- Debris**
- Containment of 12.2.5
 - Explosion
 - Analysis of 18.13.3, 18.14, 18.17.2.1, 18.17.4
 - High-order damage 18.3.2, A.18.3.2
 - Low-order damage 18.3.1
 - Scene perimeter and 18.13.1.1
 - Motor vehicle fire ignition source 22.4.5
 - Removal of 15.7.1 to 15.7.2, 24.22
 - Total burn analysis 15.9
 - Wildland fire ignition source 23.7.2.3
- Deductive reasoning** 2.3.6
- Defects, liability for** 9.6.4
- Defense Department, U.S.** 11.5.4.3
- Defining the problem** 2.3.2
- Definitions** 1.3, A.1.3
- Deflagrations** . . . 18.1, 18.2.4, 18.7, Table 18.13.2, 18.13.3.1, A.18.7.3
- Definition 1.3.31
 - Outdoor vapor cloud 18.11
 - Reflection of blast pressure front 18.5.1
 - Temperatures 18.4.3
 - Venting of 18.4.1.4
- Deformation of materials** 4.9
- Delay devices** 19.2.7.2
- Demolition**
- Documentation prior to 13.2.1
 - Injunction against 9.2.2
 - Preservation and 14.3.6
- Demonstrative evidence** *see* Evidence, Physical
- Density of materials** 3.2.1, 3.3.1, 4.17.7.2
- Depth of char** *see* Char
- Design, building** 5.2
- Computer fire model survey 5.2.5
 - Explosion damage, effect on 5.2.6
 - Materials 5.2.3
 - Planned design compared to “as-built” condition 5.2.2.5
- Design defects** 9.6.4
- Detection (definition)** 1.3.32
- Detectors and detection systems** 3.5.3.1 to 3.5.3.2, 15.6.1, 24.19
- Detonations** 18.2.4, 18.6, 18.8.2.5 to 18.8.2.6, 18.11, Table 18.13.2, 18.13.3.1
- Definition 1.3.33
 - Temperatures 18.4.3
- Diagrams** 9.3.2.1.1, 14.5.1, A.14.5.1; *see also* Drawings
- Appliance fires 21.2.2 to 21.2.3
 - Casualties
 - Burns and injuries 20.6.10
 - Death scene 20.2.2
 - Depth of calcination 4.12.2
 - Depth-of-char surveys 4.5.3.1, 15.2.4
 - Explosion dynamics 18.14
 - Explosion scene 18.13.3, 18.13.3.4
 - Floor plan 15.9, 24.19
 - Isothermal 18.17.5
 - Major fire investigations 24.20
 - Motor vehicle fires 22.7.4
 - Photo 13.2.3.3
 - Pre-fire contents Fig. 13.4.2(c)
 - Vector 15.2.3, A.15.2.3
- Dielectric withstand voltage** 14.10.2.29
- Diesel-powered vehicles** 22.5.1.3
- Dimmers** 21.5.9
- Direct current** 6.2.5 to 6.2.6
- Dishwashers** 21.6.6
- Documentary evidence** 9.3.2.2, 9.3.6.3, 9.3.6.5
- Documentation** . *see also* Diagrams; Photographs; Recording the scene
- Appliance fires 21.2
 - Casualties
 - Burn injuries 20.7.2.3
 - Death scene 20.2.2
 - Postmortem tests and examination 20.6
 - Explosion scene 18.13.1.2, 18.13.3, 18.13.3.4
 - Fire damage 12.2.7, 15.2, A.15.2.3
 - Interviews 11.4.7
 - Major fire investigations 24.19 to 24.23
 - Motor vehicle fires 22.7, 22.9
 - Physical evidence, collection of 14.5.1, A.14.5.1
- Doors** 3.5.3.2, 4.2.2, 5.4.3, 11.5.3, 15.5.5, 17.6.2
- As arson indicator 19.3.5.1, 19.3.6
 - Venting through 18.8.2.6
- Doughnut shaped patterns** 4.17.7.3
- Drawings** 13.4
- Architectural and engineering 13.4.6, 13.6
 - Death scene 20.2.2
 - Explosion scene 18.13.1.2
 - Major fire investigations 24.19, 24.20
 - Minimum (sketches) 13.4.5, 14.5.1, A.14.5.1
 - Motor vehicle fires 22.7.4
 - Selection of 13.4.3
 - Symbols 13.4.4, A.13.4.4
 - Types of 13.4.2
- Drop down** 4.16.4.2
- Definition 1.3.34
- Dryers**
- Clothes 16.3, 21.6.13
 - Hair 21.6.11
- Duff** 23.2.2.1
- Dust** *see also* Sawdust
- Concentration 8.4.1.2, 18.9.2, A.18.9.2
 - Conductive 6.9.4.4
 - Explosions 18.2.4, 18.7.3, 18.8.2.6, 18.9, 18.13.1.4, Table 18.13.2, 18.14, A.18.7.3, A.18.9
 - Explosivity 14.10.2.25
 - Ignition properties of Table 3.3.4
 - Minimum ignition energy Table 3.3.4, 18.9.5
 - Moisture 18.9.4, A.18.9.4
 - Particle size 18.9.1, A.18.9.1
 - Secondary/multiple explosions 18.9.6, 18.13.1.4, 18.14
 - Static electricity and 6.12.2.6
 - Turbulence 18.9.3
- Duty (negligence)** 9.6.1
- E-
- Educational institutions** 11.6.11
- Effective fire temperatures (definition)** 1.3.118.3
- Egress analysis** 17.4.6, A.17.4.6, B.7
- Electric blankets** 21.6.9
- Electric current** 6.2.5 to 6.2.6
- Ampacity 6.2.11

- Amperage, calculation of 6.2.16
- Overcurrent. *see* Overcurrent
- Electric meter** 6.3.3
- Electrical energy** 6.2.14 to 6.2.15
- Electrical engineers**. 12.5.3
- Electrical equipment and components** *see also* Appliances
- Arson and 19.3.2
- Collection as evidence 14.5.5 to 14.5.6
- Cords, power. 6.11.7, 19.3.2, 21.5.2.1
- Examination and testing 14.10.4
- Gas utilization equipment, electrical components of. 7.7.1.7
- As ignition source 6.1, 6.9, 19.3.2, A.6.9.4.4
- Pre-fire condition of 15.6.1
- Shipping of 14.8.2.1
- Transformers, step-down 21.5.2.2
- Vehicle 22.4.2
- Electrical explosions**. 18.2.5
- Electrical hazards** 10.2.3 to 10.2.4
- Electrical systems** 15.4; *see also* Wiring
- Building. 6.3, A.6.3.1
- Grounding requirements. 6.5
- Meter and base 6.3.3
- Phase service. 6.3.2.2
- Plans for 24.19
- Service entry 6.3.3 to 6.3.4, Fig. 6.3.3
- Service equipment Fig. 6.3.3, 6.4 to 6.5
- Single-phase service 6.3.2.1
- Considerations and cautions 6.10.6, 6.11.3, A.6.10.6
- Interpreting damage to 6.10, A.6.10.2 to A.6.10.5
- Outlets and device 6.8
- Vehicle. 22.4.2, 22.5.3, A.22.4.2.3
- Electricity**. *see also* Static electricity
- Basic. 6.2
- Fire and Chap. 6, A.6
- As ignition source 6.1, 6.9, 16.3, A.6.9.4.4
- Appliance fires 16.3, 21.4.3
- Arson 19.3.2
- Motor vehicle fires 22.4.2, 22.5.3, A.22.4.2.3
- Wildland fires 23.7.3.1
- Electronic appliances** 21.6.14
- Elevation, patterns determining** 4.16.4
- Embers**. 4.2.2, 23.3.9.1
- Emission control system, vehicle** 22.5.2
- Enclosures, and fire growth** 3.5.4, A.3.5.4.1
- Endothermic process** 3.3
- Energy Department, U.S.** 11.5.4.13
- Engineering drawings** 13.4.6
- Engineering schedules** 13.5
- Engineering specifications** 13.6, A.13.6
- Engineers** 12.5
- Engines** 7.8(e), 16.3, A.7.8
- Entrainment**. 3.5.1, 3.5.3.1, 5.2.3.2
- Definition 1.3.35
- Entry**
- Blocked/obstructed 19.3.4
- Forced 15.5.3, 15.5.5
- Limiting, to preserve scene 14.3.4.2.6
- Major fire investigations. 24.5, 24.14
- Method of 9.2.3
- By occupant. 24.7
- Right of 9.2.2 to 9.2.3, 12.2.7, 19.2.1
- Environmental conditions** 24.12
- Equipment**
- Electrical *see* Electrical equipment and components
- Improper maintenance and operation of 8.4.1.1
- Incident scene 12.4.1
- Protective *see* Protective clothing and equipment
- Specialized 12.2.6
- Escape**. 8.8.4
- Ethane** 18.15
- Ethanol** Table 3.3.4
- Ethylene** Table 18.8
- Evidence** 9.3; *see also* Witnesses
- Authentication 9.3.2.1
- Burden of proof. 9.3.5
- Casualties
- Access to medical evidence. 20.7.4
- Burn injuries 20.7.2
- Death scene 20.2.1 to 20.2.2, 20.2.4
- Inhalation 20.7.3
- Postmortem tests and documentation 20.6
- Containers. *see* Evidence containers
- Destruction, disposal or removal 9.2.2, 9.3.6, 14.11, 15.7.2; *see also* Demolition
- Documentary 9.3.2.2, 9.3.6.3, 9.3.6.5
- Documentation of. *see* Documentation
- Explosion scene 15.5.4, 15.6.3, 18.13.1.2 to 18.13.1.3, 18.13.3.1, 18.13.3.3
- Fire suppression activities, effect of 20.2.1
- Heat source 15.2.3, A.15.2.3
- Major fire scene 24.22
- Photographs 9.3.2.1.1, 9.3.6.3, 9.3.6.5, 13.2.5.8
- Physical. 9.3.2.1, Chap. 14, A.14
- Accelerants *see* Accelerants
- Appliances 14.5.6
- Arson 19.4, A.19.4
- Artifacts 14.3.2 to 14.3.3, 14.3.4.1
- Chain of custody 9.3.2.1, 14.9
- Collection of *see* Collection of evidence
- Comparison samples 14.5.3.4, A.14.5.3.4
- Conductors, damage to 6.11.6
- Contamination of 14.4, 14.5.3.1, A.14.4.2
- Definition. 14.2
- Disposition of. 14.11
- Documentation 14.5.1, A.14.5.1
- Electrical equipment and components *see* Electrical equipment and components
- Examination and testing. 14.10
- Explosion(s) *see* subhead: Explosion scene
- Fire patterns as 14.3.1; *see also* Fire patterns
- Gaseous samples 14.5.4
- Hand delivery of 14.8.1
- Identification of. 14.7
- Liquids 14.5.3
- Preservation of. 2.4.4, 14.3, A.14.3
- Shipment of 14.8.2
- Storage 14.8.3
- Traditional forensic 14.5.2
- Transportation of. 14.8
- Volatile or hazardous materials 14.8.2.2

- Preservation of 9.3.6
- Removal 9.2.2
- Rules of 9.3
- Spoliation of 9.3.6
- Testimonial 9.3.2.3, 9.7.2
- Total burn investigations 15.9
- Types of 9.3.2
- Wildland fires 23.5.2.2, 23.5.2.4, 23.8
- Evidence containers**
- Accelerants, liquid and solid 14.6.1
- Contamination of 14.4.1
- Glass jars 14.6.1.2
- Marking 14.7
- Metal cans 14.6.1.1
- Plastic bags 14.6.1.4
- Special evidence bags 14.6.1.3
- Types of 14.5.3.1, 14.6
- Evidence technicians** 24.22
- Exemplars** 14.10.4, 21.4.5 to 21.4.6
- Exhaust afterburners** 7.8(g), A.7.8
- Exhaust systems, vehicle** 22.5.2.1
- Exigent circumstances (entry method)** 9.2.3.2
- Exits** 8.3.3.1 to 8.3.3.2
- Exothermic reactions** 3.3, 18.2.3
- Experts** 9.7, 12.3, 12.5; *see also* Attorneys
- Explosion(s)** Chap. 18, A.18;
see also Damage, Explosion; Explosion scene; Explosives
- Backdraft or smoke 18.2.4(4), 18.7.4, 18.10
- Bibliography B.8
- Blast yield correlated with damage incurred 18.17.3, A.18.17.3
- BLEVEs *see* BLEVEs
- Building design and construction, effect of 5.2.6
- Causes of 4.17.8, 4.19.2, 16.1
- Analyzing 18.17, A.18.17.3
- Fuel source 18.13.2.5, 18.13.2.7, 18.15
- Ignition source 18.16
- Origin *see* subhead: Origin (epicenter)
- Characterization of 18.3, Table 18.13.2, A.18.3.2
- Chemical 18.2.3, 18.4.3, A.18.2.3
- Combustion 18.2.4
- Confined fuel gas and liquid vapor 18.6.3
- Deaths and injuries from *see* Casualties
- Definition 1.3.36, 18.1
- Dust *see* Dust, Explosions
- Effects of 18.4 to 18.5
- Electrical 18.2.5
- Evidence of 15.5.4, 15.6.3, 18.13.1.2 to 18.13.1.3, 18.13.3.3
- Fires and Table 18.13.2
- Fuel gas *see* Fuel gases, Explosions
- Gas *see* Gas/vapor explosions
- High-order 18.3, Table 18.13.2, 18.13.2.2, A.18.3.2
- Definition 1.3.36.1
- Human injury criteria Table 18.13.3.1(a), 18.13.3.3
- Identifying 18.13.2.1
- Low-order 18.3, Table 18.13.2, 18.13.2.2, A.18.3.2
- Definition 1.3.36.2
- Mechanical 18.2.1, A.18.2.1
- Multiple *see* subhead: Secondary
- Nonseated 18.7, 18.13.2.3, 18.14, A.18.7.3
- Nuclear 18.2.6
- Origin (epicenter) 15.6.3, 18.6, 18.13.1.3, 18.13.2.6, 18.14
- Outdoor vapor cloud 18.11
- Pooled flammable/combustible liquid 18.7.2, 18.13.1.4
- Pressure vessel 18.6.2
- Property damage criteria Table 18.13.3.1(b)
- Responsibility for, determination of 16.6
- Seat of 18.6
- Definition 1.3.36.3
- Seated 18.6, Table 18.13.2, 18.13.2.3, 18.14
- Definition 1.3.36.4
- Secondary 18.8.4, 18.9.6, 18.13.1.4, Table 18.13.2, 18.14
- Definition 1.3.36.5
- Smoke *see* Backdraft
- Types of 18.2, 18.13.2.4, 18.13.2.7, A.18.2
- Vapor *see* Gas/vapor explosions
- Venting *see* Venting
- Explosion dynamics analysis** 18.14
- Explosion scene**
- Analysis of cause *see* Explosion(s), Causes of
- Detailed assessment 18.13.3
- Damage effects 18.13.3.1
- Evidence collection 18.13.1.2 to 18.13.1.3, 18.13.3.3
- Force vectors, identifying 18.13.3.4
- Preblast and postblast damage 18.13.3.2
- Identification procedures
- Fuel source 18.13.2.5, 18.13.2.7
- Ignition source 18.13.2.8
- Of incident as explosion 18.13.2.1
- Type of explosion 18.13.2.4, 18.13.2.7
- Initial assessment 18.13.2
- Investigation of 18.13
- Perimeters of 18.13.1.1, 18.13.1.3
- Safety 18.13.1.4
- Search pattern for 18.13.1.3
- Security of 18.13.1
- Explosionproof outlets and fixtures** 6.8.3
- Explosive devices** 10.3
- Explosive incidents** *see also* Explosion scene
- Investigation of 18.12.3, 18.15
- Safety 18.13.1.4
- Explosive materials (definition)** 1.3.38
- Explosives** 18.6.1, 18.12, 18.13.1.2, Table 18.13.2, A.18.12
- Blast yield 18.17.3, A.18.17.3
- Definition 1.3.37
- High 18.6.1, 18.12.2
- Definition 1.3.37.1
- Initial screen assessment 18.13.2
- Low 18.12.1
- Definition 1.3.37.2
- Exposed surface (definition)** 1.3.39
- Extinguish (definition)** 1.3.40

-F-

Failure

- Definition 1.3.41
- Negligence, as element of 9.6.1
- Odorant 7.2.4, 7.9.7.1, 18.8.3, A.18.8.4
- Failure analysis** 2.4.5, Chap. 17, A.17
- Definition 1.3.42
- Mathematical modeling 17.4, A.17.4.6 to A.17.4.7

- Systems analysis 17.3, A.17.3.1
Time lines 17.2
- Failure mode and effects analysis (FMEA)** 17.3.2
- Fall down** *see* Drop down
- Fault currents** 6.3.4, 6.7, 6.9.5, 6.10.5, A.6.10.5
High-resistance faults 6.9.6, 22.4.2.1
- Fault trees** 17.3.1, A.17.3.1
- Federal agencies** 11.5.4, 15.2.1
- Federal rules of evidence** 9.3.1
- Felonies** 9.4.1.1
- Fertilizers** 3.1.1.2
- Fibers, and static electricity** 6.12.2.6
- Financial institutions** 11.6.9
- Financial stress as arson indicator** 19.4.3, 19.4.8.2.5
- Finish rating** 4.16.1.3
Definition 1.3.44
- Fir (wood)** Table 3.3.1
- Fire**
Definition 1.3.45
Flash fire
Definition 1.3.45.1
Fire pattern 4.19.2
Ventilation-controlled fire 3.1.1.2, 3.5.3.2, 3.6
Definition 1.3.45.2
- Fire Administration, U.S.** 11.5.4.14
- Fire alarms** *see* Alarms
- Fire analysis (definition)** 1.3.46
- Fire barriers** *see* Barriers
- Fire bombs** 19.2.7.1
- Fire breaks** 23.3.8.1
- Fire brick** Table 4.8
- Fire cause** *see* Cause
- Fire characteristics, effect on human behavior of** 8.3.4, A.8.3.4.4
- Fire deaths and injuries** *see* Casualties
- Fire departments, municipal** 11.5.1.9
Unavailable, as arson indicator 19.4.7.3
- Fire development** 3.5, 17.6.2, A.3.5; *see also* Fire spread
Arson 19.2.4, 19.2.8, A.19.2.4
Building systems, effect of 5.1 to 5.2
Ceilings, effect of 3.5.3, 3.5.4.2
Compartment fires 3.5.3.2, 3.5.4.3
Confined fires 3.5.3
Enclosures, effect of 3.5.4
Flame height in 3.5.5, A.3.5.5
Flashover 3.5.3.2, 3.5.4.1, A.3.5.4.1
Plumes 3.5.1
Unconfined fires 3.5.2
Ventilation opening 3.5.4.1, 15.5.5
- Fire doors, sabotage to** 19.3.5.1
- Fire duration, and char depth** 4.5.5
- Fire dynamics** 17.4.7, A.17.4.7; *see also* Fire science
Bibliography B.1
Definition 1.3.48
Fire patterns 4.2, A.4.2.2.1
Heat transfer analysis 17.4.1
Thermodynamic chemical equilibrium analysis 17.4.4
- Fire engineering technicians** 12.5.5.3
- Fire engineering technologists** 12.5.5.2
- Fire fighters**
Contamination of evidence by 14.4.3
Preservation of fire scene by 14.3.4
Wildland fires, observation of origin of 23.5.1.2 to 23.5.1.3
- Fire fighting, effect of** 3.6
- Fire head (wildland fire)** 23.3.3
- Fire heel (wildland fire)** 23.3.4, 23.5
- Fire investigations**
Authority to conduct 9.2.1
Basic method 2.4
Conducting 2.4.3
Definition 1.3.49
Fuel gas systems 7.9, A.7.9
Functions 12.3
Major Chap. 24, A.24
Nature of 2.1
Planning *see* Planning the investigation
Purpose of 12.2.8
Reporting procedure 2.5; *see also* Documentation
Resources for 24.10
Scientific method and 2.2 to 2.4, 16.2.5, 16.6
Static electricity ignitions 6.12.7
Teams *see* Teams
Time period 9.2.3.2, 12.2.4, 12.2.6
- Fire investigations organizations** 11.6.4, 11.6.6
- Fire marshals** 11.5.3.10, 24.23
- Fire models** 15.7.4
Data required for 17.6
Mathematical modeling 17.4, A.17.4.6 to A.17.4.7
- Fire patterns** Chap. 4, 14.3.1, 15.2, A.4; *see also* Char
Appliances 21.3.2, 21.4.1
Area 4.19
Arrow 4.3.4, 4.17.6
On building contents 4.16.3, 15.7.3
Calcination 4.12, A.4.12.1
Circular shaped 4.17.7 to 4.17.8
Clean burn 4.11
Collapsed furniture springs 4.14, A.4.14
Commercial fuel gas 4.17.9
Debris removal, importance of 15.7.2
Definition 4.3
Die-out pattern 23.4.4.3
Dynamics of 4.2, A.4.2.2.1
Fall down (drop down) 4.16.4.2
Full room involvement, patterns generated by 4.2.4
Geometry 4.17, A.4.17, B.5
On glass *see* Glass
Horizontal surfaces
Bottoms of 4.17.7.1
Penetrations of 4.3.3
Hot gas layer-generated patterns 4.2.3
Hourglass *see* Hourglass fire patterns
On human body 20.3.6
Intensity (heat) 4.4.2
Inverted cone 4.17.2
Irregular 4.17.7.2, 4.17.8, 19.2.7.3
Linear 4.18
Lines or areas of demarcation 4.3.1
Locations of 4.16, B.3
Loss of material 4.3.4
Low burn 4.16.4.1
Material distortion 4.20
Melting of materials 4.8

- Motor vehicle fires 22.8
- Movement 4.4.1
- Object placement and 4.15, 4.18.2
- Oxidation 4.7
- Photographing 15.2.2
- Plume generated 4.2.1
- Pointer *see* Arrow patterns
- Size of B.3
- Smoke and soot 4.10
- Spalling 4.6, A.4.6.1
- Surface effect 4.3.2
- Thermal expansion and deformation of materials 4.9
- Truncated cone. 4.2.2.1, 4.9, 4.17.5, A.4.2.2.1
- Types of 4.4
- “U” shaped *see* “U”-shaped fire patterns
- “V” shaped *see* “V”-shaped fire patterns
- Ventilation-generated. 4.2.2, A.4.2.2.1, B.3
- Victim injuries. 4.3.5
- Wildland fires 23.4.1, 23.4.4.3, 23.4.6.3
- Fire point** 14.10.2.7, 14.10.2.9
- Fire propagation** *see* Fire spread
- Fire protection devices/systems** 5.2.2, 15.4, 15.6.1, 24.19
- Sabotage of 19.3.5
- Fire protection engineers** 12.5.5.1
- Fire scene** *see also* Explosion scene
- Appliance fires 21.2
- Communications at 24.17
- Examination 24.24; *see also* Origin determination
- Motor vehicle fires 22.7.4
- Preliminary assessment 15.3, 24.11
- Preservation of 13.2.1, 14.3, A.14.3
- Reconstruction *see* Fire scene reconstruction
- Recording *see* Recording the scene
- Safety. *see* Safety, fire scene
- Sanitary and comfort needs at 24.16
- Search patterns. 24.21
- Security 12.2.7, 14.3, 23.5.2.1, 23.6, 24.15, A.14.3
- Site alterations 15.3.4
- Size and complexity of 12.2.4
- Temporary lighting. 24.13
- Total burn 15.9
- Wildland fire. 23.5.2.1, 23.6
- Fire scene reconstruction** 11.7
- Arson 19.2.1
- Definition 1.3.51
- Fire science** Chap. 3, A.3
- Bibliography B.2
- Chemistry of combustion. 3.1
- Combustion products. 3.6
- Definition 1.3.52
- Experts 12.5.5
- Fire development 3.5
- Fuel load 3.4
- Heat transfer. 3.2
- Ignition 3.3
- Fire shutters** 19.3.5.1
- Fire spread** 15.2.3, 15.4, A.15.2.3; *see also* Fire development
- Building materials, effect of. 5.2.3.7
- Building systems, effect of 5.1
- Conduction as mechanism of 3.2.1
- Construction types, effect of. 5.3.1 to 5.3.2
- Definition. 1.3.53
- Direction of 4.11
- Fuel gas and 7.1.2
- Human factors related to 8.7
- Motor vehicle fires. 22.7.4
- Scenarios 15.8
- Smoke patterns to determine. 3.6, 4.10; *see also* Fire patterns
- Wildland fires. 23.3, 23.5.2.3
- Fire stops** 5.3.1.2
- Fire storms** 23.3.9.2
- Fire suppression** *see* Suppression
- Fire testing** *see* Testing
- Fire tetrahedron** 3.1.1
- Fire walls, vehicle** 22.6
- Fireballs** 18.4.3, 18.17.5
- Firebrands** 15.6.3, 18.4.3, 23.3.9.1
- Fireplaces** 19.3.2
- Fire-resistive assemblies** 19.3.5.1
- Fire-resistive membranes** 5.3.1
- Firesetters** *see* Arson
- Fireworks** 23.7.2.10
- Firing out** 23.3.8.3
- First item ignited** *see* Material first ignited
- Fish meal** Table 3.3.5
- Flame front**
- Definition. 1.3.55
- Translational velocity. 18.8.2.1
- Flame speeds** 18.8.2.1, A.18.8.2.1
- Flameover** 3.5.3.2, 5.2.2
- Definition. 1.3.56
- Flames**
- Clean burn produced by 4.11
- Definition. 1.3.54
- Heat shadowing and 4.15.1
- Height of 3.5.5, A.3.5.5
- Human behavior, effect on 8.3.4.1
- Length 3.5.4.3
- Penetrations caused by 4.3.3
- Premixed (definition) 1.3.54.1
- Temperature 4.8.1
- Flaming brands** *see* Firebrands
- Flaming combustion** 3.1.1.2, 3.1.1.4, 3.3.6
- Flammability, of building materials** 5.2.3.2
- Flammable (definition)** 1.3.57
- Flammable (explosive) range** 3.1.1.2
- Definition. 1.3.59
- Flammable limits** 3.1.1.2, A.3.1.1.2
- Chemicals. 14.10.2.22
- Definition. 1.3.58
- Flammable liquids** *see* Liquids
- Flares** 7.1.2
- Flash fire** *see* Fire
- Flash point of a liquid** *see* Liquids
- Flashover** 3.2.2, 3.5.3.2, Fig. 3.5.3.2(d), 3.5.4.1, 4.16.1.4, 4.17.7.2, A.3.5.4.1
- Appliance damage and 21.3.3
- Ceiling layer temperature and 3.5.4.2
- Definition. 1.3.60
- Fire location and 3.5.4.3, 4.2.2.1
- Fire patterns. 4.16.1.4, 4.17.7.2, 4.19.1
- Heat release rate and 3.4, 3.5.4.1

- Room design and time to 5.2.2, 5.2.2.2
Smoke production rates 3.6
- Floor assemblies** 5.4.1
- Floor coverings** 4.16.1.4, 4.17.7.2, 4.18.2, 14.10.2.16, 14.10.2.20
- Floor plans** 15.9, 24.19
- Floors** 17.6.1 to 17.6.2
Cracks/seams in 4.16.1.4
Fire patterns on 4.10, 4.16.1, 4.17.7.2, 4.18.2, A.4.16.1.4
Holes in 4.2.2, 4.2.4, 4.3.3, 4.16.1.4, 15.7.1
Manufactured homes 5.3.1.6.1
- Foam, polyurethane** 3.6
- Foam rubber** Table 3.3.5
- Foams, extinguishing** 23.3.8.4
- Force vectors** 18.13.3.4, 18.14
- Forced entry** 15.5.3, 15.5.5
- Forensic (definition)** 1.3.61
- Forensic physical evidence** 14.5.2
- Freedom of Information Act** 11.2.1
- Frictional heating** 22.3.3
- Fuel(s)**
Combustion of 3.1.1.1
Definition 1.3.62
Gaseous *see* Fuel gases
High surface-to-mass ratio 16.4
Liquid 18.15, 22.3.1 to 22.3.2, A.22.3.1
Combustion of 3.1.1.1, 3.1.1.4
Properties of Table 22.3.1
Properties of Tables 22.3.1 to 22.3.3
Solid 22.3.3
Target 3.5.3.2
Definition 1.3.62.1
Type and configuration of 16.4, 18.5
In vehicle fires 22.3, 22.5.1, 22.8.1, A.22.3.1, A.22.5.1.2
Wildland fires 23.2, 23.3.5, 23.4.6.1
- Fuel gases** 15.6.2
Appliances 7.7 to 7.8, 7.9.3.5, A.7.8
Building systems Chap. 7, A.7
Burners 7.5.4, 7.9.3.3
Combustion of 3.1.1.1
Commercial, fire patterns of 4.17.9
Components, common system 7.5
Confined 18.6.3
Definition 1.3.63
Depth-of-char patterns with 4.5.4
Explosions 18.6.3, 18.7.1, 18.8, 18.14
Investigations, impact on 7.1.1
Secondary explosions 18.8.4, 18.13.1.4
Fugitive *see* Fugitive fuel gases
As ignition sources 7.1.1.1 to 7.1.1.3
Investigations of fires/explosions, impact on 7.1.1
Investigations of fuel gas systems 7.9, A.7.9
Jets 4.18.3, 18.17.5
Leaks 7.1.1.1, 7.9.3, 7.9.5, 7.9.7, A.7.9.3.8, A.7.9.7
Odorization of 7.2.4, 18.8.3, A.18.8.4
Piping and valves 7.3, 7.5.2 to 7.5.3, 7.6, 7.9.3.1, A.7.3.1
Pocketing 18.8.4, Table 18.13.2
Types of 7.2, 7.7.1.2, A.7.2
Underground migration of 7.9.7, 18.8.3, Table 18.13.2, A.7.9.7
In vehicle fires 22.3.2, 22.5.1.4
- Fuel injection systems** 22.5.1.2, A.22.5.1.2
- Fuel lines, vehicle** 22.5.4.1
- Fuel loads** 3.4, 5.2.1, 5.2.2.2, 5.2.4, 15.6.1
As arson indicator 19.2.3, 19.2.5
Definition 1.3.64
- Fuel oil** 3.6
- Fuel source, explosion** 18.13.2.5, 18.13.2.7, 18.15
- Fuel tanks** 22.8.1
- Fuel turbulence** 18.8.2.3
- Fuel-air mixtures** 18.8.1 to 18.8.2
- Fuel-air ratio** 3.1.1.2, 18.8.2.1, A.18.8.2.1
- Fuel-controlled fire** 3.1.1.2, 3.5.3.2
Definition 1.3.65
- Fugitive fuel gases** 7.1.1.1, 7.9.5.2 to 7.9.5.4, 7.9.7, 18.8.3, 18.14, 18.16, A.7.9.7
- Full room involvement** 3.5.3.2, 4.2.4, 4.16.1.4, 4.17.7.2, 4.19.1
- Furniture** Table 3.4, 4.3.3, 4.16.1.4, 4.16.3, 14.10.2.14 to 14.10.2.15, 20.7.1.2
- Furniture springs, collapsed** 4.14, A.4.14
- Fuses** 6.4, 6.6, 21.5.2.4, 21.5.3.2.1
- Fusible plugs** 7.4.2.5

-G-

- Garages, appliance installation in** 7.7.1.3, A.7.7.1.3
- Gas chromatography (GC)** 4.17.7.2, 14.10.2.1, 18.15
- Gas detection surveys** 7.9.5.2
- Gas odorant** 7.2.4, 7.9.7.1, 18.8.3, 18.15, A.18.8.4, B.6
- Gases** *see also* Gas-vapor explosions
Combustion properties of common flammable gases Table 18.8
Convection 3.2.2
Definition 1.3.66
Drilling activity, as wildland fire ignition source 23.7.3.2
Explosivity 14.10.2.25
Fuel *see* Fuel gases
Hot gas layer-generated smoke patterns 4.2.3
Ignitable, at fire scene 10.2.7
Ignition of 3.3.3, Table 3.3.4, 16.3
Inhalation of hot/toxic gases by fire victims 20.5.2.2, 20.7.3.1.1
Initial fuel 16.4
Irritant 20.7.3.1.2
Leaks *see* Leaks, gas
LP *see* LP-Gas
Manufactured 7.2.3.3
Measurement of gases present in fires 14.10.2.23
Narcotic 20.7.3.1.1
Natural *see* Natural gas
Properties of flammable gas 18.8
Samples of 14.5.4
Static electric accumulations 6.12.2.5
Toxic 24.12
Venting of *see* Venting
- Gasification process** 3.3
- Gasoline** Table 3.3, Table 3.3.4, Table 3.4, 4.8.1, 22.1, 22.5.1.1, 22.5.4
As accelerant 19.2.2
- Gas/vapor explosions** 4.19.2, 18.2.4, 18.6.3, 18.8
Blast yield 18.17.3, A.18.17.3
Interpretation of damage 18.8.2, A.18.8.2
Minimum ignition energy 18.8.1, Table 18.13.2, A.18.8.1
Multiple explosions 18.8.4
Odorant verification 7.2.4, 7.9.7.1, 18.8.3, A.18.8.4
Pocketing 18.8.4, Table 18.13.2
Underground migration of fuel gases 18.8.3, Table 18.13.2
Venting 18.8.2.6

Gauging devices, propane 7.4.2.3 to 7.4.2.4
Geographic clustering 19.4.1.1
Glass 4.8.1
 Appliance housings 21.5.1.6
 Breaking of 4.13.1, 15.5.3, 18.3.1, A.4.13.1
 Melting and softening 4.8
 Patterns on 4.13
 Staining of 4.13.3
 Tempered 4.13.2, A.4.13.2
 Thermal conductivities of 3.2.1
 Window 4.13, 15.5.3, 18.3.1, 18.13.3.2, 18.13.3.4
Glass jars, for evidence 14.6.1.2
Globules 6.10.3, 6.10.6.2 to 6.10.6.3, A.6.10.3
Glowing combustion 3.3, 4.2.2, A.3.3
 Definition 1.3.67
Gold Table 4.8
Government agencies 11.2.1, 11.5, 22.7.3
Grain Table 3.3.4, Table 3.3.5
Grass (wildland fuel) 23.2.2.4, 23.3.5, 23.4.3, 23.4.4.2
Ground fault circuit interrupters 6.6.2.3
Ground faults 6.3.4, 6.6, 6.9.4.3, 6.9.5, 6.10.2, 6.11.8, A.6.10.2
 Definition 1.3.68
Ground fuels 23.2.2, 23.3.5.5
Grounded conductors 6.3.2.1, 6.7, 6.9.5
 Floating neutral 6.5.1
 Melting of 6.10.2, 6.11.4, A.6.10.2
 Staples driven through 6.11.8, A.6.11.8
Grounding, electrical 6.5, 6.12.5.2, 7.6.7
Grounding conductors 6.3.2.1, 6.5, 6.7
Guide (definition) 1.3.69, A.1.3.69
Gypsum plaster/wallboard Table 3.2.1, 4.5, 4.7, 4.12

-H-

Hair dryers/curlers 21.6.11
Hardwood Table 3.3.4
Hay Table 3.3.5
Hazardous materials
 As evidence 14.8.2.2
 At fire scene 10.2.7, 15.7.2
Hazards
 Definition 1.3.70
 Explosion scene 18.13.1.2
 Fire scene 10.1.3, 10.2, 12.2.5, 23.9.1, 24.12, A.10.1
Health, personal 10.1.4, 10.2.7; *see also* Casualties
Health and Human Services Department, U.S. 11.5.4.4
Health departments, municipal 11.5.1.6
Heat 3.1.1.3
 Capacity 3.2.1
 Of combustion 5.2.3.2, 5.2.4, 14.10.2.12
 Conducted *see* Conduction
 Definition 1.3.71, A.1.3.71
 Distortion 4.20
 Fire patterns 4.4.2
 Flux 3.3, 3.5.3.2, 4.16.1.4, 14.10.2.20, A.4.16.1.4
 Definition 1.3.72
 Of ignition 16.3
 Definition 1.3.73, A.1.3.73
 Radiant *see* Radiant heat
 Radiated 4.11, 4.15.1
 Shadowing 4.15.1
 Source 15.2.3, A.15.2.3
 Transfer (thermal conductivity) 3.2 to 3.3, 5.2.3.4, A.3.3

Heat detectors *see* Detectors and detection systems
Heat generation, rate of 3.3.5
Heat release rate (HRR) 3.4, 3.5, 3.5.3.2, 4.2.2, 17.6.2
 As arson indicator 19.2.3
 Building materials 5.2.3.2
 Definition 1.3.74, A.1.3.74
 Flame height and 3.5.5
 For flashover 3.4, 3.5.4.1
 Occupancy type, effect of 5.2.4
 Plume-generated pattern and 4.2.1
 Spalling and 4.6
 Test 14.10.2.24, 14.10.2.26
Heat resistance, of building materials 5.2.3.6
Heaters
 As ignition sources 16.3
 Space 21.6.8
 Vaporizers 7.4.4
Heating
 Frictional 22.3.3
 Self-heating 3.3.5
 Spontaneous *see* Spontaneous heating
Heating, ventilating, and air-conditioning (HVAC) systems 3.5.3.2, 15.4, 24.19
Heating appliances, fuel gas 7.8, A.7.8
Heating elements 21.5.7
Heat-producing devices 6.2.9, 6.9.2.2
 As ignition source 16.3
 Initial fuel location and 16.4
Heavy equipment fires 22.13
Heavy timber construction 5.3.1.5
Hemlock Table 3.3.1
High explosives *see* Explosives
High resistance faults 6.9.6, 22.4.2.1
High temperature accelerants (HTA) 19.2.4, A.19.2.4
High-density materials 3.2.1, 3.3.1, 3.4
High-order explosions *see* Explosion(s)
Holes
 In carpets 4.2.4
 Effect of 15.5.5
 In floors 4.2.2, 4.2.4, 4.3.3, 4.16.1.4, 15.7.1
 In horizontal surfaces 4.3.3
Hose streams, use of 14.3.4.2.1
Hot conductors *see* Ungrounded conductors
Hot gas layer 3.5.3.2, 4.2.3
Hot surfaces, as ignition source 22.4.3, A.22.4.3
Hourglass fire patterns 4.2.1, 4.17.3
Housekeeping 8.4.1.2, 15.6.1
Housing and Urban Development Department, U.S. 11.5.4.5
Human behavior, fire-related Chap. 8, A.8; *see also* Arson
 Fire, effect of characteristics of 8.3.4, A.8.3.4.4
 Fire initiation, factors related to 8.4
 Accidental fires 8.4.1
 Children and fire 8.5
 Incendiary fires 8.5 to 8.6
 Recalls 8.4.2
 Violations of fire safety codes and standards 8.4.4
 Fire spread, factors related to 8.7
 Groups 8.3.2, A.8.3.2.1 to A.8.3.2.2
 Peer pressure, firesetting motivated by 19.4.8.2.1(b)
 Permanence of group 8.3.2.3
 Retaliation by group, fire set as 19.4.8.2.3(d)

- Roles and norms of group 8.3.2.4
 - Size of group 8.3.2.1, A.8.3.2.1
 - Structure of groups 8.3.2.2, A.8.3.2.2
 - History of research 8.2, A.8.2
 - Individual characteristics, effect of 8.3.1
 - Cognitive comprehension limitations 8.3.1.2
 - Physical limitations, effect of 8.3.1.1
 - Physical setting, familiarity with 8.3.1.3
 - Physical setting, effect of characteristics of 8.3.1.3, 8.3.3
 - Recognition and response to fires 8.8
 - Action taken 8.8.3
 - Decision to act 8.8.2
 - Escape factors 8.8.4
 - Perception of danger 8.8.1
 - Witnesses, information from 8.8.5
 - Wildland fires 23.7.2
 - Human body, static electricity and** 6.12.2.7
 - Human injuries and deaths** *see* Casualties
 - Humidification** 6.12.5.1
 - Humidity, relative** 23.3.7.3
 - Hydrocarbon fuels** 3.6, 4.8.1, 14.10.2.12, 18.2.4
 - Hydrocarbon vapors** 3.5.3.2, 4.17.7.2
 - Hydrogen** 3.1.1.1 to 3.1.1.2, 3.6, Table 18.8, 22.3.2, 22.5.3
 - Hydrogen peroxide** 3.1.1.2
 - Hyperthermia** 20.5.2.1
 - Hypothesis**
 - Cause determination 16.2.5, 16.7
 - Development of 2.3.5
 - Testing of 2.3.6
 - Hypoxia** 20.5.5, 20.7.3.1.1
- I-**
- Identification of evidence** 14.7
 - Ignitable liquids** *see* Liquids
 - Ignitable materials** 5.2.3.1, 15.6.1
 - Ignition** 3.3, A.3.3; *see also* Ignition energy; Ignition sources; Ignition time; Temperature(s), Ignition
 - Autoignition (definition) 1.3.75.1
 - Definition 1.3.75
 - Factor (cause) 16.5
 - Of gases 3.3.3, 16.3
 - Heat of 16.3
 - Definition 1.3.73, A.1.3.73
 - Of liquids 3.3.2
 - Process 16.3
 - Properties, selected materials Table 3.3.4
 - Radiant *see* Radiant ignition
 - Self-ignition 3.3.5
 - Definition 1.3.75.2
 - Sequence 16.5
 - Of solids 3.3.1
 - Spontaneous 3.3, 3.3.5
 - Definition 1.3.75.3
 - Materials subject to Table 3.3.5
 - Wildland fires 23.7.1.2
 - Of wood 3.3.1
 - Ignition energy** 3.3
 - Building materials 5.2.3.1
 - Definition 1.3.76
 - Of gases 3.3.3
 - Minimum 7.1.1.2, 18.8.1, 18.9.5, Table 18.13.2, A.18.8.1
 - Static arcs and 6.12.4, A.6.12.4
 - Thin and thick materials 3.3.1
 - Ignition sources** 3.3
 - As arson indicator 19.2.3
 - Cause determination 16.3
 - Cigarettes *see* Cigarettes, as ignition source
 - Electrical *see* Electricity
 - Equipment, improper maintenance and operation of 8.4.1.1
 - Explosions 18.5, 18.8.2.2, 18.13.2.8, 18.16, A.18.8.2.2
 - Location and magnitude of 18.8.2.5, A.18.8.2.5
 - During fire investigation 10.2.7
 - Fire/explosion injuries, cause of 20.7.1.3
 - Fuel gases 7.1.1.1 to 7.1.1.3
 - Human role in fire initiation 8.4
 - Motor vehicle fires 22.4, A.22.4
 - Multiple 18.16
 - Static electricity 6.12.4, 6.12.6, A.6.12.4
 - Temperatures of selected Table 3.3
 - Wildland fire 23.5.2
 - Ignition switch, vehicle** 22.8.2
 - Ignition temperature** *see* Temperature(s)
 - Ignition time** 3.3.1, Figs. 3.3.1(a) and (b)
 - Definition 1.3.77
 - Inadequate warnings** 9.6.4
 - Incendiary devices** 10.3, 14.3.4, 16.3, 19.2.7
 - Incendiary fires** *see* Arson
 - Incendive arcs** 6.12.3, 6.12.7, A.6.12.3
 - Incident, analysis of** 2.4.5
 - Incident Command System (ICS)** 24.8, A.24.8
 - Incident information, basic** 12.2
 - Incinerators** 7.8(g), A.7.8
 - Incomplete combustion** 3.6, 18.2.4(4)
 - Inductive reasoning** 2.3.4
 - Industry experts** 12.5.6
 - Information, release of** 24.23
 - Information, sources of** Chap. 11, A.11.1
 - Electronic 11.3.4
 - Forms of 11.3
 - Freedom of Information Act 11.2.1
 - Governmental 11.5
 - Interviews 11.4
 - Legal considerations 11.2
 - Private 11.6
 - Purpose of obtaining 11.1.1
 - Reliability of 11.1.2
 - Verbal 11.3.1
 - Visual 11.3.3
 - Written 11.3.2
 - Infrared spectrophotometer (IR)** 14.10.2.3
 - Inhalation injuries** 20.7.3, 20.8
 - Initial assessment** *see* Preliminary assessment
 - Initial fuel** 16.4
 - Injuries** *see* Casualties
 - Inorganic materials** 3.1.1.1, 3.3.5
 - Instructions, disregard or ignorance of** 8.4.1.3, 8.4.1.5, 8.4.1.8
 - Insulating effect, and self-heating** 3.3.5
 - Insulation, electrical** 6.1, 6.3.4, 6.7.5, 6.10.2 to 6.10.3, 6.10.5, 6.10.6.1, 6.11.5, 6.11.7, A.6.10.3, A.6.10.5
 - Insulation resistance test** 14.10.2.30
 - Insurance, as arson indicator** 19.4.6, 19.4.8.2.5
 - Insurance agents/adjusters** 9.5, 12.5.8
 - Insurance Commissioner's Office, state** 11.5.3.8

Insurance industry 9.5, 11.6.10, 15.9
Insurance Institute for Highway Safety 22.7.3
Intensity fire patterns 4.4.2
Interior, structure 5.2.1, 15.3.4, 15.6
Interior Department, U.S. 11.5.4.6
Interior finish
 Structure 5.2.1, 5.3.1.3, 5.3.1.5
 Vehicle 22.6.1
International Association of Arson Investigators 11.6.5
Interstitial spaces 5.2.2.4
Interviews 9.3.3, 11.4, 24.18
Inverted cone fire pattern 4.17.2
Investigations *see* Fire investigations
Investigators
 Access to site 24.5, 24.7, 24.14: *see also* Entry, Right of
 Assignment of 2.4.1
 Authority of 9.2.1, 14.11
 Expert testimony by 9.7
 Fatigue 10.1.5, 24.12
 Health of 10.1.4, 10.2.7, 10.3.2 to 10.3.3
 Insurance company 9.5
 Preservation of scene, responsibility for 14.3.5
 Responsibility for fire/explosion, role in assessing 16.6.2
 Safety of *see* Safety, fire scene
 Supervision of photographer by 13.2.3.4
 Unaccompanied 10.1.1
Iron (metal) 4.7, Table 4.8, 4.8.2; *see also* Steel
Irons, clothes 21.6.12
Irregular fire patterns 4.17.7.2, 4.17.8, 19.2.7.3
Isochar Fig. 13.4.2(f), 15.2.4
 Definition 1.3.78
Isothermal diagram 18.17.5

-J-

Jets, fuel gas 4.18.3, 18.17.5
Joint investigations 24.2 to 24.4
Joule (definition) 1.3.79
JP-4 Table 3.3
Justice Department, U.S. 11.5.4.11
Juvenile firesetters 8.5, 23.7.2.9

-K-

Kerosene Table 3.3, Table 3.3.4, Table 3.4
Kilowatt (definition) 1.3.80
Kindling temperature(s) *see* Temperature(s), Ignition
Knobs, movement of 14.3.4.2.4

-L-

Labor Department, U.S. 11.5.4.7
Laboratory examination, of evidence 14.10.1
Lamp filaments, as ignition source 22.4.2.3, A.22.4.2.3
Larch (wood) Table 3.3.1
Lateral extension, plume boundary 4.2.1
Lawsuits *see* Civil litigation
Lead (metal) Table 4.8, 4.8.2
Leaks, gas 4.5.4, 7.1.1.1, 7.9.3, 7.9.5, 7.9.7, 18.13.1.4,
 18.15, 22.5.1.3, A.7.9.3.8, A.7.9.7
Leaves 23.2.2.3
Legal considerations Chap. 9, A.9.1
 Arson reporting statutes 9.5
 Burden of proof 9.3.5
 Canada A.9.1
 Civil litigation 9.6, 9.7.2

Confidential communications 11.2.3
Criminal prosecution 9.4, A.9.4.1.1
Death scene 20.2.3
Evidence 9.3
Expert testimony 9.7
Fire/explosion injuries 20.7.1.4, A.20.7.1.4
Freedom of Information Act 11.2.1
Legal counsel 9.1, 9.2.2, 12.5.7, A.9.1
Preliminary 9.2
Privileged communications 11.2.2
Liability *see also* Legal considerations
 Negligence 9.6.1
 Product 9.6.3 to 9.6.4
 Strict 9.6.4
Lightning 6.9.4.1, 6.12.8, 23.7.1.1, 23.9.1, A.6.12.8
Lightning detection networks 11.6.15
Lights and lighting
 Appliance 21.5.5, 21.5.8
 Branch circuits 6.7
 Fixed 6.8.3
 Fluorescent 21.5.5, 21.6.15
 Fuel gas illumination 7.8(f), A.7.8
 Lamp filaments, as ignition source 22.4.2.3, A.22.4.2.3
 Light bulbs, distorted 4.20.1
 Residential 21.6.15
 Switches 6.8.1
 Temporary 24.13
Linear patterns 4.18, 19.2.2
Lines of demarcation 4.3.1 to 4.3.2, 4.3.4
 Calcination 4.12, A.4.12.1
 Between clean burn and sooted areas 4.11
 Depth of char diagram 4.5.3.1
 Heat effects, caused by 4.4.2
 Irregular patterns 4.17.7.2
 Oxidation 4.7
 “V” pattern 4.17.1
 Wildland fires 23.4.6.3
Linseed oiled rags 3.3.5
Liquids *see also* Accelerants, Liquid
 Atomized 3.3.2
 Combustible *see also* Accelerants, Liquid
 Definition 1.3.81.1
 Pooled *see* Pooled liquids
 Spray paint 6.12.2.4
 Static electricity and 6.12.2.1 to 6.12.2.2, A.6.12.2.1
 Convection 3.2.2
 Electrical charges on surface of 6.12.2.2
 Flammable *see also* Accelerants, Liquid; Fuel(s), Liquid
 Definition 1.3.81.2
 Inverted cone patterns and 4.17.2.1
 Pooled *see* Pooled liquids
 As secondary heat source 15.2.3, A.15.2.3
 Spray painting of 6.12.2.4
 Static electricity and 6.12.2.1 to 6.12.2.2, A.6.12.2.1
 Vapor explosions *see* Gas/vapor explosions
 Flash point of a liquid 3.3, 3.3.2, 14.10.2.6 to 14.10.2.10
 Definition 1.3.81.3
 Ignitable 4.2.2, 4.18.1, 14.3.4; *see also* Accelerants, Liquid
 Definition 1.3.81.4

Doughnut-shaped patterns caused by 4.17.7.3
 At fire scene 10.2.7
 Melted, liquefied materials, fire spread by 5.2.3.6
 Spray painting of 6.12.2.4
 Ignition of 3.3.2, Table 3.3.4
 Low conductivity 6.12.2.1, A.6.12.2.1
 Melted solids compared 4.17.8
 Pooled *see* Pooled liquids
Litigation, civil 9.6, 9.7.2; *see also* Legal considerations
Live loads 5.2.2.1
Loading of materials, and spalling 4.6
Loads, building 5.2.2.1
Location, of incident 12.2.1
 Arson 19.3.1 to 19.3.2, 19.4.1.1
 In compartment 3.5.4.3
Loss, due to negligence 9.6.1
Low burn patterns 4.16.4.1
Low explosives *see* Explosives
Low-density materials 3.2.1, 3.3.1, 3.4
Lower flammable/explosive limit 4.19.2, 18.8.2.1
Low-order explosions *see* Explosion(s)
LP-Gas 7.2.2, 18.8.2.2, 18.15, A.18.8.2.2, A.18.8.4; *see also* Propane
 Building systems 7.4, A.7.4
 Fire patterns of 4.17.9
 Storage containers 7.4.1 to 7.4.3, A.7.4.1
Lubrication systems, vehicle 22.5.4.1

-M-

Machinery, as wildland fire ignition source 23.7.2.7
Magnesium Table 4.8, 18.9
Major fire investigations, management of Chap. 24, A.24
Manufactured gases 7.2.3.3
Manufactured homes 5.3.1.6.1
Manufactured wood structural elements 5.3.1.7
Manufacturers, liability of 9.6.3 to 9.6.4
Manure Table 3.3.5
Maps 9.3.2.1.1, 18.13.3
Marsh gas 18.15
Masonry 4.6, 5.3.4.2
Mass ratio 3.3.1, 16.4
Mass spectroscopy 18.15
Mass spectrometry (MS) 14.10.2.2
Matches 19.2.7.1
Material distortion 4.20, 23.4.6.3
Material first ignited 3.5.3.2, 4.2, 16.4, A.4.2.2.1
 Definition 1.3.82
Materials, testing of 17.6.2
Materials engineers 12.5.1
Mathematical modeling 17.4, A.17.4.6 to A.17.4.7
Mattresses Table 3.4
Maximum pressure (explosion) 18.4.1.4, 18.5
Measurement, units of 1.4, A.1.4
Mechanical engineers 12.5.2
Mechanical explosions 18.2.1, A.18.2.1
Mechanical gouges, conductor 6.10.6.4, A.6.10.6.4
Mechanical power systems, vehicle 22.5.4 to 22.5.6
Mechanical sparks Table 3.3, 22.4.4, A.22.4.4
Medical examiners 11.5.2.5, 20.2.3
Meetings, team 12.4, 24.9
Melting of materials 4.3.2, 4.8, 4.17.8, 5.2.3.6
 Electrical conductors
 Arcing, caused by 6.11.1
 Fire, caused by 6.11.1

Metals *see* Metals, Melting
Melting temperature(s) 4.8, 21.5.1.1 to 21.5.1.3, 22.3.3
Memorandum of Understanding (example) 24.3
Metal alloys 22.3.3
Metal cans 14.6.1.1
Metal construction 4.20.2, 5.3.4.1
Metal fasteners 3.2.1
Metal powders 3.3.5
Metals *see also* Conductors; Mechanical sparks
 Alloying of *see* Alloying of metals
 Appliance housing 21.5.1.1 to 21.5.1.3
 Burn patterns on metal cabinets 4.7
 Burning 4.8.1
 Color changes 4.3.2
 Distortion of 4.2.2, 4.3.2, 4.20.2
 Dusts 18.9
 Experts on 12.5.1
 Melting 4.3.2, 4.8, 6.9.4.3, 6.9.5, 6.10.2 to 6.10.5, 6.10.6.2, 21.5.1.1 to 21.5.1.3, 22.3.3, A.6.10.2 to A.6.10.5
 Oxidizing of *see* Oxidizing of metals
 Thermal conductivities of 3.2.1
 In vehicle fires 22.3.3, 22.4.4, A.22.4.4
Meters
 Electric 6.3.3
 Gas 7.3.4
Methane Table 3.3.4, 18.15
Methanol Table 3.3, Table 3.3.4
Methodology, fire investigation Chap. 2
Methyl acetylene Table 18.8
Methyl ethyl ketone Table 3.3.4
Michigan v. Clifford 9.2.3.3
Michigan v. Tyler 9.2.3.2
Microwave ovens 21.6.7
Mill construction 5.3.3
Minimum ignition energy 18.8.1, 18.9.5, A.18.8.1
Miranda Rule 9.3.4
Misdemeanor 9.4.1.1
Mists 3.3.2
Mobile homes *see* Manufactured homes
Models, as evidence 9.3.2.1.1
Models, fire 15.7.4
 Data required for 17.6
 Mathematical modeling 17.4, A.17.4.6 to A.17.4.7
Modular homes 5.3.1.6.2
Molotov cocktails 19.2.7.1
Motion pictures 9.3.2.1.1, 11.3.3, 13.2, 13.2.4
Motor vehicle fires Chap. 22, A.22
 Examination of motor vehicle 22.8
 Fire scene, recording of 22.7
 Fuels in 22.3, 22.5.1, 22.8.1, A.22.3.1, A.22.5.1.2
 Heavy equipment 22.13
 Ignition sources 22.4, A.22.4, A.22.4.4
 Information sources 22.7.1, 22.7.3
 Recreational vehicles 22.4.2, 22.4.2.4, 22.12
 Safety concerns 22.2
 Stolen vehicles 22.10
 Structures, vehicles in 22.11
 System identification and function 22.5, 22.8.1, A.22.5.1.2
 Total burns 22.9, 22.10.1
Motor vehicles, as wildland fire ignition source 23.7.2.7
Motors, appliance 21.5.6
Movement fire patterns 4.4.1

- Multiple explosions** *see* Explosion(s), Secondary
- Multiple fires** 14.3.4, 19.2.1, 19.3.5.2
- Municipal government** 11.5.1
- N-
- Nails and nail plates** 3.2.1
- Narrow “V” pattern** 4.2.1, 4.17.1
- National Association of Fire Investigators** 11.6.4
- National Certification Board** 11.6.4
- National Crime Information Center (NCIC)** 22.7.1
- National Fire Incident Reporting System (NFIRS)** 11.5.4.14
- National Fire Protection Association (NFPA)** 11.6.1
- National Highway Traffic Safety Administration** 22.7.3
- National Insurance Crime Bureau** 22.7.1
- National Oceanic and Atmospheric Administration (NOAA)** 11.5.4.15
- Natural fire cause** 16.2.2, 16.6.3, 23.7.1
- Natural gas** 3.6, 18.8, 18.8.2.2, 18.8.3, 18.15, A.18.8.2.2
- Appliances 7.7.1.2
- Building systems 7.2.1, 7.3, 7.5.1, 7.5.4, A.7.3.1
- Burners 7.5.4, 7.9.3.3
- Fire patterns of 4.17.2.2, 4.17.9
- Ignition properties Table 3.3.4
- As vehicle fuel 22.3.2, 22.5.1.4
- Natural resources, state department of** 11.5.3.7
- Negative pressure phase (explosion)** 18.4.1.2
- Negligence** 9.6.1
- Neutral conductors** *see* Grounded conductors
- Nichrome conductors** 6.10.5, A.6.10.5
- Nickel** Table 4.8
- Nitrogen** 3.1.1.1, 3.6
- Noncombustible construction** 5.3.4
- Noncombustible material**
- Definition 1.3.83
- Wildland fires 23.4.6
- Noncombustible surfaces** 4.3.2
- Clean burn on 4.11
- Inverted cone patterns on 4.17.2.1
- Nonflammable (definition)** 1.3.84
- Nonseated explosions** 18.7, 18.13.2.3, 18.14, A.18.7.3
- Notes** 13.3, 14.5.1, 15.2.1, 18.13.3
- Appliance fires 21.2.4
- Motor vehicle fires 22.7.4
- Nuclear explosions** 18.2.6
- Nylon carpet** 4.17.7.2
- Nylon jackets, insulation** 6.7.5.3
- O-
- Oak** Table 3.2.1, Table 3.3.1, 4.17.7.2
- Occupancy**
- Change in 5.2.4
- Nature of 5.2.1, 5.2.4, 15.3.3
- Occupant access to fire site** 24.7
- Occupants, behavior of** *see* Human behavior, fire-related
- Odorization, gas** *see* Gas odorant
- Offsets, conductor** 6.10.5, A.6.10.5
- Ohm (definition)** 1.3.85
- Ohm’s Law** 6.2.9, 6.2.13, 6.2.15 to 6.2.16
- Oil drilling, as wildland fire ignition source** 23.7.3.2
- Oils, animal and vegetable** 3.3.5
- Open flames** 4.10, 22.4.1
- Openings, ventilation** 3.5.4.1, 15.5.5
- Organic materials** 3.3.5
- Organizing investigation** 12.3, 24.4
- Origin** *see also* Origin determination
- Area of 4.2, 15.1, 15.8, 16.3, A.4.2.2.1
- Accelerants in 19.2.7.3
- Appliances in 21.2.1, 21.3.1
- Clean burn and 4.11
- Definition 1.3.86.1
- Wildland fires 23.5 to 23.6
- Point of 4.2, 15.1, 16.3, A.4.2.2.1
- Appliances at 21.3.2 to 21.3.3
- Areas of high damage and 4.2.2
- Definition 1.3.86.2
- Explosion 18.4.1
- Multiple 19.2.1
- Pyrolysis products deposits and 4.10
- Wildland fire 23.6
- Origin determination** Chap. 15, A.15; *see also* Origin
- Appliances in area of 21.3
- Contents, analysis of 15.7.3
- Debris removal 15.7.1 to 15.7.2
- Doors and windows, condition of 15.5.3, 15.5.5
- Explosion(s) *see* Explosion(s), Origin (epicenter)
- Fire damage assessment 15.2, 15.5.5, A.15.2.3
- Fire scene reconstruction *see* Fire scene reconstruction
- Fire-spread scenario 15.8
- Pre-fire conditions 15.5.1, 15.6.1
- Preliminary scenario development 15.4
- Preliminary scene assessment *see* Preliminary assessment
- Purpose of 11.1, A.11.1
- Smoke patterns to determine 3.6
- Structural examination
- Exterior 15.3.3, 15.5.5
- Interior 15.3.4
- Surface examination, detailed
- Exterior 15.5
- Interior 15.6
- Total burns 15.9
- Utilities, interior and exterior 15.4, 15.5.2, 15.6.2
- Outdoor vapor cloud explosions** 18.11
- Outside surfaces, fire patterns on** 4.16.2, Fig. 4.20.2
- Ovens** 21.6.1, 21.6.7
- Overcurrent** 6.9.3, 6.10.5, A.6.10.5
- Definition 1.3.87
- Overcurrent protection** 6.3.4, 6.6, 6.10.5, 6.11.8 to 6.11.9, A.6.10.5, A.6.11.8
- Appliances 21.5.2.4, 21.5.3.2.1
- Branch circuits 6.7
- Vehicles 22.4.2
- Overhaul** 14.3.4.2.2
- Overheating connections** 6.10.4, A.6.10.4
- Overload** 6.2.16, 6.6, 6.9.3, 6.10.5, 6.11.9, A.6.10.5
- Definition 1.3.88, A.1.3.88
- Motor vehicle fire ignition source 22.4.2.1, 22.5.3
- Overpressure damage** 18.13.3.1 to 18.13.3.2
- Oxidants, at explosion scene** 18.13.1.2
- Oxidation** 3.3.5, 4.3.2, 4.7
- Oxide interface** 6.9.2.3
- Oxidizers, liquid** 19.2.4, A.19.2.4
- Oxidizing agents** 3.1.1.2
- Oxidizing of metals** 4.3.2, 4.7, 6.10.4, 6.10.6.3, 21.5.1.1, A.6.10.4, A.6.10.6.3, A.21.5.1.1
- Oxygen** 3.1.1.1 to 3.1.1.2, 3.3.5, 22.3.2, 22.5.3

- Oxygen deficiency** 3.1.1.2, 3.5.3.2, 8.3.4.3, 10.2.7, 20.7.3.1.1
 Definition 1.3.89
- Oxygen-enriched atmospheres** 3.1.1.2, 20.8.1
- P-**
- Paint** 4.3.2, 4.5, 4.7
 Blisters 18.8.2.2
 Spray 6.12.2.4
- Paper trash** Table 3.4
- Paraffin** Table 4.8
- Paraffin wax–sawdust device** 19.2.7.1
- Parting arcs** 6.9.4.3, 6.10.2, 6.11.8 to 6.11.9, A.6.10.2, A.6.11.8
- Patterns**
 Fire *see* Fire patterns
 Search
 Explosions 18.13.1.3
 Major fire investigation 24.21
- Peak heat release rates** Table 3.4
- Penetrations**
 As arson indicator 19.3.5.1
 Floor/ceiling assemblies 5.4.1
 Horizontal 4.3.3
- Pensky-Martens closed tester** 14.10.2.8
- Personal computers** 21.6.14
- Personal effects, of fire victim** 20.6.8
- Personnel, specialized** 12.3, 12.5
- Petroleum products** 4.10; *see also* Gasoline; LP-Gas
- Photo diagram** 13.2.3.3
- Photographs** 11.3.3, 11.6.7, 24.20; *see also* Photography
 Aerial 13.2.5.11
 Appliance 13.2.5.7, 21.2.1 to 21.2.4, 21.4.4
 Casualties
 Burn injuries 20.7.2.3
 Death scene 20.2.2
 Postmortem examination 20.6.9
 Court use of 9.3.2.1.1, 9.3.6.3, 9.3.6.5, 13.2.3.5, 13.2.5.8 to 13.2.5.10
 Crowd or people 13.2.5.2
 Diagrams 13.2.3.3
 Documenting collection of evidence 14.5.1, A.14.5.1
 Evidence 13.2.5.8
 Explosion scene 18.13.1.3, 18.13.3, 18.13.3.3, 18.13.3.4
 Exterior 13.2.5.4
 During fire 13.2.5.1
 Fire patterns 15.2.2
 Fire suppression 13.2.5.3
 Fireground activities 13.2.5
 Interior 13.2.5.6
 Mosaics 13.2.3.2
 Motor vehicle fires 22.7.4 to 22.7.4
 Presentation of 13.2.7
 Scene preservation 13.2.1
 Sequential 13.2.3.1
 Structural 13.2.5.5
 Suggested 12.2.7, 13.2.3, 13.2.5
 Supervision by fire investigator 13.2.3.4
 Timing of 13.2.1, 13.2.3.3
 Utility 13.2.5.7
 Victim 13.2.5.9
 Witness viewpoint 13.2.5.10
- Photography** 13.2; *see also* Photographs; Videotapes
 Cameras 13.2.2
 Composition and techniques 13.2.3
 Digital technology 13.2.2.3
 Film 13.2.2.2
 Filters 13.2.2.5
 Lenses 13.2.2.4
 Lighting 13.2.2, 13.2.2.6, 13.2.3.3
 Prints versus slides 13.2.7.1
 Special types of 13.2.2.7
 Tips 13.2.6, 15.2.2
- Physical evidence** *see* Evidence, Physical
- Physical setting of fire, and fire-related behavior** 8.3.3
- Pilot lights** 7.5.4.2, 7.9.3.2
- Piloted ignition temperature(s)** *see* Temperature(s), Ignition
- Pilotless igniters** 7.5.4.3
- Pine** Table 3.2.1, Table 3.3.1
- Pine shavings** 3.4
- Piping and pipelines, gas** 7.3, 7.5, 7.9.3.1, 7.9.4 to 7.9.7, A.7.3.1, A.7.9.4.2
 Bar holing 7.9.5.3
 Corrosion 7.9.3.7
 Uncapped 7.9.3.4
- Pitting** 6.10.4, 6.10.6.3, A.6.10.4, A.6.10.6.3
- Plank and beam construction** 5.3.1.3
- Planning the investigation** 2.4.2, Chap. 12, A.12
 Basic incident information 12.2
 Case management 12.6, A.12.6
 Major investigations 24.4 to 24.6, 24.11, 24.25
 Organizing investigative functions 12.3, 24.4
 Pre-investigation team meeting 12.4
 Preliminary scenarios 15.4, 24.11
 Responsibilities 12.1, 12.2.8, 12.4
 Specialized personnel and technical consultants 12.3, 12.5; *see also* Attorneys
- Plans, building** 15.9, 24.19
- Plastered surfaces** 4.3.2
 Calcination of 4.12, A.4.12.1
 Thermal expansion of 4.9
- Plastic(s)** 3.4, 4.8.1
 In appliances 21.3.3, 21.5.1.4
 Bags Table 3.4, 14.6.1.4
 Building materials, use as 5.2.3.6
 Burning of 4.17.7.2, 4.17.8
 Chairs Table 3.4
 Char 4.5
 Combustion products 3.6
 Definition 1.3.91, A.1.3.91
 Dust 18.9
 Experts on 12.5.1
 Floor patterns and 4.16.1.4
 Ignition of 3.3.1, 14.10.2.27
 Melting of 4.8, 4.17.8
 Soot formation 4.10
 Thermal conductivities of 3.2.1
 Thermoplastics *see* Thermoplastics
 Thermoset 3.3.1
 Trash bags Table 3.4
 In vehicle fires 22.3.3
- Platform frame construction** 5.3.1.1
- Platinum** Table 4.8

- Plug fuses** 6.6.1.1
- Plugs**
- Appliance 21.5.2.1
 - Fusible 7.4.2.5
- Plume-generated patterns** 4.2.1
- Plumes** 3.5.1, 4.2.1
- Confined fires 3.5.3
 - Definition 1.3.92
 - Location of fire in compartment and 3.5.4.3
 - Temperature 3.5.4.3
 - Unconfined fires 3.5.2
- Pocketing of fuel gases** 18.8.4, Table 18.13.2
- Point of origin** *see* Origin
- Pointer patterns** *see* Arrow patterns
- Police departments** 11.5.1.8, 11.5.2.6, 11.5.3.9, 20.2.3
- Polyethylene** 6.7.5.3, Table 3.2.1, Table 3.3.4
- Polyolefins** 6.7.5.3
- Polystyrene** Table 3.2.1, Table 3.3.4
- Polyurethane** 3.6, Table 3.2.1, Table 3.3.4, Table 3.4, 3.6, 4.3.3
- Polyvinyl chloride (PVC)** 20.5.3, Table 3.2.1, Table 3.3.4, Table 3.4, 6.7.5.1, 6.7.5.3, 6.10.6.1
- Pooled liquids** 4.17.7.2, 18.7.2, 18.13.1.4
- Porcelain** Table 4.8
- Positive pressure phase (explosion)** 18.4.1.1
- Post and frame construction** 5.3.1.4
- Postal Service, U.S.** 11.5.4.12
- Postblast damage** 18.13.3.2
- Postflashover** *see* Full room involvement
- Pot metal** Table 4.8, 4.8.1
- Potassium nitrate** 3.1.1.2
- Potential fuel type, identification of** 18.13.2.5, 18.13.2.7
- Power** 6.2.14 to 6.2.15
- Power steering systems** 22.5.6
- Power tools, use at fire scene of** 14.3.4.2.5, 14.4.3
- Preblast damage** 18.13.3.2
- Pre-fire conditions** 15.5.1, 15.6.1
- Preflashover conditions** Fig. 3.5.3.2(c)
- Preinvestigation team meeting** 12.4
- Preliminary assessment**
- Explosion scene 18.13.2
 - Fire scene 15.3, 15.7, 24.11
- Premixed flame** *see* Flames
- Prescribed fires** 23.7.2.6
- Preservation (definition)** 1.3.93
- Preservation of evidence** 13.2.1, 14.3, A.14.3
- Pressure** 4.13.1, 18.5, A.4.13.1
- Pressure regulators, gas** 7.4.3, 7.5.1, 7.7.1.4, 7.9.3.6
- Pressure relief devices, LP-Gas** 7.4.2.1
- Pressure rise, rate of** 14.10.2.25, 18.3, 18.4.1.4, 18.5, 18.7, 18.8.2.5, 18.9.1, 18.9.3, A.18.3.2, A.18.7.3, A.18.8.2.5, A.18.9.1
- Pressure testing, fuel piping** 7.9.4, 7.9.6, A.7.9.4.2
- Pressure vessel explosions** 18.6.2
- Privileged communications** 11.2.2
- Probable cause** 9.2.3.3
- Product liability** 9.6.3 to 9.6.4
- Products**
- Labels 8.4.1.3 to 8.4.1.4, 8.4.1.6 to 8.4.1.8
 - Misuse of 8.4.1.3 to 8.4.1.8
 - Recalls of 8.4.2
- Products of combustion** *see* Combustion products
- Propagation reactions** 18.2.3, 18.4.1.3
- Propane** Table 3.3.4, Table 18.8, 18.8.3, 18.15, 22.3.2
- Appliances 7.7.1.2
 - Building systems 7.2.2, 7.3 to 7.4, 7.5.1, 7.5.4, A.7.3 to A.7.4
- Burners 7.5.4, 7.9.3.3
- HD5 7.2.3.2
- Vaporizers 7.4.4
- As vehicle fuel 22.3.2
- Property damage, explosions** Table 18.13.3.1(b)
- Property Insurance Loss Register (PILR)** 11.6.10
- Protected areas** 4.3.5, 4.15.2, 4.18.2
- Protective clothing and equipment**
- Planning 12.2.5 to 12.2.6, 12.4.1
 - At scene 10.1.2, 12.2.5, 12.4.1, 14.4.2, 24.12, A.10.1
 - Wildland fires 23.9.2
- Proximate cause** 9.6.1
- Definition 1.3.95
- Purpose of document** 1.2
- Purpose of investigation** 12.2.8
- PVC** *see* Polyvinyl chloride (PVC)
- Pyrolysis** 3.5.3.2, 4.3.2, 4.17.7.2
- Definition 1.3.96
 - Forced 3.3
- Q-**
- Quartz** Table 4.8
- Quick response sprinklers** 3.5.3.2
- R-**
- Radiant heat** 3.2.3, 3.3.1, 3.5.3.2, 5.2.2, 14.10.2.20
- Burns caused by 20.7.2.4
 - Definition 1.3.97
 - Penetrations caused by 4.3.3
- Radiant ignition** 3.5.1, 3.5.4.2, 4.16.1.4
- Radiated heat** 4.11, 4.15.1
- Radiation** 3.2.2 to 3.2.3, 3.3, 3.5.3.1 to 3.5.3.2, 4.16.1.4, 12.2.5
- Definition 1.3.98
 - Holes in floors caused by 4.2.2
- Radiological terrorism** 10.3.3
- Radios** 21.6.14
- Rags**
- Baled Table 3.3.5
 - Linseed oiled Table 3.3.5
- Railroad, as wildland fire ignition source** 23.7.2.8
- Range (stove)** 7.8(c), 21.6.1, A.7.8
- Rate of char** 4.5.2, A.4.5.2
- Rate of heat generation** 3.3.5
- Rate of heat release** *see* Heat release rate
- Rate of heat transfer** 3.2.1, 3.3
- Rate of pressure rise** *see* Pressure rise, rate of
- Rates, smoke production** 3.6
- Rates, smoke release** 14.10.2.24, 14.10.2.26
- Real estate industry** 11.6.7, 15.9
- “Reasonable time”** 9.2.3.2
- Receptacles** 6.8.2
- Recommended practice (definition)** 1.3.100, A.1.3.100
- Reconstruction, fire scene** *see* Fire scene reconstruction
- Recorder, county** 11.5.2.1
- Recording the scene** 12.2.7, Chap. 13, 24.20, A.13;
see also Documentation
- Records** *see* Documentation
- Recreational vehicles** 22.4.2, 22.4.2.4, 22.12
- Red oak** Table 3.3.1
- Red oxide** 4.7
- Redwood** Table 3.3.1
- Referenced publications** Chap. 25, App. C
- Reflection, blast pressure front** 18.5.1

- Refraction, blast pressure front** 18.5.2
Refrigerators 7.8(d), 21.6.5, A.7.8
Regional fire investigations organizations 11.6.6
Regulation, state department of 11.5.3.5
Regulations, violation of 9.6.2
Rekindle (definition) 1.3.101
Relays, appliance 21.5.4
Release of information 24.23
Reliability of information 11.1.2
Reporting procedure 2.5; *see also* Documentation
Resins 18.9
Resistance heating 6.9.2
Response time, fire protection device 3.5.3.1
Responsibility (definition) 1.3.102
Responsibility for fire/explosion, determination of 16.6
Revenge 19.4.8.2.3, A.19.4.8.2.3
Revenue, state department of 11.5.3.4
Right of entry *see* Entry, Right of
Risk (definition) 1.3.103
Rock 4.7
Rollover 3.5.3.2
 Definition 1.3.104
Roof assemblies 5.4.1
Roof coverings, testing 14.10.2.19
Roofs 4.3.3, 18.3.1 to 18.3.2, A.18.3.2
 Manufactured homes 5.3.1.6.1
Room fire experiments 14.10.2.21
Room size 5.2.2.2, 17.6.1
Roots 23.2.2.2
Rubber 6.7.5.2
Rugs *see* Carpeting
Rust 3.1.1.4, 4.7
- S-
- Sabotage** 19.3.5
“Saddle burns” 4.17.10
Safety, fire scene Chap. 10, A.10.1
 Bystanders 10.2.6
 Criminal or terrorist acts 10.3
 Dangerous atmospheres 10.2.7
 Electrical hazards 10.2.3 to 10.2.4
 Explosion scenes 18.13.1.4
 Fire scene reconstruction 15.7.1
 Hazards 10.1.3, 10.2
 Health and 10.1.4, 10.2.7, 10.3.2 to 10.3.3
 Investigator fatigue 10.1.5
 Major fires 24.12
 Motor vehicle fire 22.2
 Protective clothing and equipment for *see* Protective clothing and equipment
 Standing water 10.2.5
 Status of suppression 10.2.1
 Structural stability 10.2.2, 18.13.1.4
 Tools and equipment, exposure of 10.3.4
 Utilities 10.2.3
 Wildland fires 23.9
Safety monitors 24.12
Salvage 14.3.4.2.3
Samples *see also* Evidence, physical
 Air 18.15
 Appliances 14.5.6
 Chain of custody 9.3.2.1, 14.9
 Comparison 14.5.3.4, A.14.5.3.4
 Containers for 14.6
 Electrical equipment and components 14.5.5 to 14.5.6
 Gaseous 14.5.4
 Liquid 14.5.3.1 to 14.5.3.2, 14.5.3.4, A.14.5.3.4
 Solid 14.5.3.3 to 14.5.3.4, A.14.5.3.4
 Sufficiency of, for testing 14.10.3
Sanitary facilities 24.16
Satellite imaging, wildland fires 23.5.1.5
Sawdust Table 3.3.5
Scenario development 15.4
Schedules, architectural and engineering 13.5
Scientific method 2.2 to 2.4, 16.2.5, 16.7
 Definition 1.3.105
Scientists 12.5.1
Scope of document 1.1
Scorching 18.8.2.2
Search patterns
 Explosion scene 18.13.1.3
 Major fire investigation 24.21
Search techniques and equipment, wildland fires 23.5.2 to 23.5.3
Search warrants
 Administrative 9.2.3.3
 Criminal 9.2.3.4
Seated explosions *see* Explosion(s)
Second item ignited 3.5.3.2
Secondary explosions *see* Explosion(s)
Secretary of State 11.5.3.1
Security
 Explosion scene 18.13.1
 Fire scene 12.2.7, 14.3, 23.5.2.1, 23.6, 24.15, A.14.3
Seismic effect 18.4.4, 18.13.3.1
Seismic effect injuries 20.8.2.4
Self-contained breathing apparatus (SCBA) 24.12
Self-heating 3.3.5, 3.3.6
 Definition 1.3.106
Self-ignition *see* Ignition
Self-ignition temperature *see* Temperature(s)
Service entrance Fig. 6.3.3
 Conductors 6.10.3, A.6.10.3
 Overload in 6.10.5, A.6.10.5
Service equipment, electrical Fig. 6.3.3, 6.4 to 6.5
 Arson and 19.3.2
 Cables, service drop/service lateral 6.3.2.1
Setaflash closed tester 14.10.2.10
Sewer gas Table 18.8, 18.15
Sheriff’s department 11.5.2.6
Short circuits 6.2.16, 6.3.4, 6.9.4.3, 6.9.5, 6.10.2, 6.11.8 to 6.11.9, A.6.10.2, A.6.11.8
 Definition 1.3.107
Shrapnel effect 18.4.2, 18.6, 18.13.3.1
Shrapnel injuries 20.8.2.2
Shutters, fire 19.3.5.1
Silicone 6.7.5.3
Silk 3.6
Silver 6.2.12, Table 4.8
Site alterations 15.3.4
Size of incident 12.2.4
Sketches *see* Drawings
Sleeving 6.10.5, A.6.10.5
Smoke 3.6
 Behavior of 3.5.3.2, 3.6
 Color of 3.6
 Definition 1.3.108

- Fire victim, exposure to smoke of 20.3.4, 20.5.4, 20.7.3.1.3
- Human behavior, effect on 8.3.4.2
- Smoke barriers** 5.4.2
- Smoke condensates** 4.10
 - Definition 1.3.109
- Smoke detectors** *see* Detectors and detection systems
- Smoke explosions** *see* Backdraft
- Smoke explosions (backdraft)** 18.2.4(4), 18.7.4, 18.10
- Smoke patterns** 3.6, 4.10
- Smoke production rates** 3.6
- Smoke release rates** 14.10.2.24, 14.10.2.26
- Smoke staining** 15.5.4
- Smoking materials** *see* Cigarettes, as ignition source
- Smoldering** 3.1.1.2, 3.1.1.4, 3.3, 4.3.3, 4.10, 4.14, A.3.3
 - Definition 1.3.110
 - Transition to flaming combustion 3.3.6
 - Wildland fire 23.9.1
- Snow** 12.2.3
- Society of Fire Protection Engineers** 11.6.2
- Sofas** Table 3.4
- Softwood** Table 3.3.4
- Soil** 4.7
- Solder (tin)** Table 4.8
- Solenoids** 21.5.4
- Solid fuels** 22.3.3
 - Combustion of 3.1.1.1, 3.1.1.4
 - Gasification process 3.3
 - Properties of 22.3.3
- Solids** *see also* Solid fuels
 - Animal and vegetable 3.3.5
 - Building materials, change in physical state of 5.2.3.6
 - Conduction 3.2.1
 - Fire spread rate 3.5.1
 - Ignition of 3.3.1, Table 3.3.4
 - Melted, liquids versus 4.17.8
- Solo investigations** 10.1.1
- Soot** 3.5.3.2, 3.6, 4.7
 - Definition 1.3.111
 - Fire victim, exposure to soot of 20.3.4, 20.5.4
 - Patterns 4.10, 4.13.3
 - Wildland fires 23.4.6.2
- Space heaters** 21.6.8
- Spalling** 4.2.2, 4.6, A.4.6.1
 - Definition 1.3.112
 - Interpretations of 4.6.1, 4.11, A.4.6.1
- Sparks**
 - Definition 1.3.113
 - Electric 6.9.5
 - Definition 1.3.113.1
 - Mechanical Table 3.3, 22.4.4, A.22.4.4
- Specialized personnel** 12.5
- Specifications, architectural and engineering** 13.6, A.13.6
- Speed controllers** 21.5.9
- Spoilation (definition)** 1.3.114
- Spontaneous heating** 23.7.1.2
 - Definition 1.3.115, A.1.3.115
- Spontaneous ignition** *see* Ignition
- Spray painting** 6.12.2.4
- Springs, furniture** 4.14, A.4.14
- Sprinklers** 3.5.3.1 to 3.5.3.2, 3.5.3.2
- Spruce** Table 3.3.1
- Stainless steel** 4.7
- Stairways** 19.2.3, 19.3.5.1
- Standards**
 - Compliance to 7.9.2
 - Definition 1.3.116, A.1.3.116
 - Violations of 8.4.4, 9.6.2
- Standing water** 10.2.5
- State Department, U.S.** 11.5.4.8
- State government** 11.5.3
- Static electricity** 6.9.4.2, 6.12, A.6.12, A.18.8.1
 - Controlling accumulations of 6.12.5
 - Generation of 6.12.2, A.6.12.2
 - As ignition source 6.12.4, 6.12.6, A.6.12.4
 - Incendive arcs A.6.12.3
 - Investigating ignitions 6.12.7
- Steady state** 3.2.1
- Steel**
 - Alloying of 4.8.2
 - Appliance housings 21.5.1.1, A.21.5.1.1
 - Arcing 6.9.5
 - Beams, bending of 4.9
 - Distortion of 4.20.2
 - Melting 4.8
 - Oxidation 4.7
 - Residential construction, steel-framed 5.3.1.6.3
 - Terminals 6.10.4, A.6.10.4
 - Tools Table 3.3
- Steiner Tunnel Test** 5.2.3.7
- Stoichiometric ratio** 3.1.1.2, 18.8.2.2
- Stoves** 7.8(c), 21.6.1, A.7.8
- Stranded conductors** 6.10.2, 21.5.2.1, A.6.10.2
- Street departments, municipal** 11.5.1.4
- Stress in materials, and spalling** 4.6
- Strict liability** 9.6.4
- Structural members** 4.16.1.3, 4.17.6, 18.3.2, A.18.3.2
- Structural stability** 10.2.2, 18.13.1.4, 24.12
- Structures** *see also* Building systems
 - Dimensions of 17.6.1
 - Explosions in 18.1, 18.3, A.18.1, A.18.3.2
 - Damage analysis 18.17.2.2, 18.17.4
 - Displacement of structural components 18.13.3.3
 - Level of damage 18.8.2.2
 - Overpressure condition 18.13.2.1, 18.13.3.1
 - Seismic effect 18.4.4
 - Venting *see* Venting
 - Exterior 15.3.3, 15.5, 15.5.5
 - Height of 8.3.3.3
 - Interior 15.3.4, 15.6
 - Sabotage of 19.3.5
 - Total burn investigation 15.9
 - Types and use of 12.2.5
 - Vehicles burned in 22.11
 - Venting 18.8.2.6, 18.14
- Styrene** 3.6
- Suppression**
 - At death scene, effect on evidence 20.2.1
 - Definition 1.3.117
 - Devices 15.6.1
 - Heavy equipment, suppression systems for 22.13
 - Holes caused by 15.5.5
 - Human behavior, effect of suppression systems on 8.3.3.5
 - Manual 5.2.1

Preservation of scene by suppression personnel 14.3.4
 Status of 10.2.1
 Wildland fires 23.3.8
Surface area 3.3.1, 4.3.2
Surface effect 4.3.2, 4.5
Surface fuels 23.3.5.5
Surface temperature 3.5.3.2
Surfaces, and spalling 4.6
Surface-to-mass ratio 16.4
Surrounding areas 15.3.1 to 15.3.2
Suspicious origin 9.5, 16.2.4 to 16.2.5, 16.7; *see also* Arson
Swamp gas 18.15
Switch loading 6.12.2.3, A.6.12.2.3
Switches 6.8.1
 Appliance 21.5.3
 Fire fighters, movement by 14.3.4.2.4
 Main 6.4
 Vehicle 22.8.2
Symbols 13.4.4, A.13.4.4
Systematic approach *see* Scientific method
Systems analysis 17.3, A.17.3.1

-T-

Tag closed tester 14.10.2.6
Tag open cup 14.10.2.9
Tamarack Table 3.3.1
Tanks
 LP-Gas 7.4.1 to 7.4.3, A.7.4.1
 Static electricity and 6.12.2.2 to 6.12.2.3
Tape recorders 13.3
Target fuel *see* Fuel
Tarry products 3.6
Team Leader Committee 24.5, 24.9, 24.23
Teams 12.1
 Meetings of 12.4, 24.9
 Organization of 24.4, 24.8, A.24.8
Technical consultants 12.5
Television stations, local 11.6.14
Televisions Table 3.4, 21.6.14
Temperature switches 21.5.3.2.2
Temperature(s)
 Absolute 3.2.3
 Definition 1.3.118.1, A.1.3.118.1
 Ambient 3.3, 3.3.2, 6.2.11, 23.3.7.2
 Arcs 6.9.4
 Autoignition
 Of chemicals 14.10.2.11
 Definition 1.3.118.2
 Of wood 3.3.1
 Definition 1.3.118, A.1.3.118
 Determination 4.8.1
 Effective fire (definition) 1.3.118.3
 Fire 4.8.1
 Fire victim, internal body temperature of 20.6.6
 Heat and 3.2
 Ignition 3.3
 Building materials 5.2.3.1
 Definition 1.3.118.4, A.1.3.118.4
 Dusts 18.9.5
 Fuel gases 7.1.1.2
 Liquids 3.3.2

Ignition sources, burning and sparking temperatures of 3.3,
 Table 3.3
 Melting *see* Melting temperature(s)
 Radiation and Fig. 3.2.3
 Self-ignition
 Chemicals 14.10.2.11
 Definition 1.3.118.6
Terrorist acts, fire resulting from 10.3, 19.4.8.2.6, A.19.4.8.2.6
Testimony 9.3.2.3
 Expert 9.7
Testing 14.10, 17.5, A.17.5.2
 Accelerant 14.5.3, A.14.5.3.4
 Appliances 21.2.5, 21.4.5 to 21.4.6
 ASTM 14.10.1 to 14.10.2
 Comparative 14.10.4
 Data required for 17.6
 Explosion fuels 18.15
 Factors affecting results 14.10.1
 Fuel gas piping 7.9.4 to 7.9.6, A.7.9.4.2
 Leaks 18.15
 Limitations, fire tests 17.5.3
 Methods 14.10.2, 17.5.2, A.17.5.2
 Physical evidence 14.10
 Role, fire tests 17.5.1
 Sufficiency of samples for 14.10.3
 Textiles 14.10.2.13, 14.10.2.16, 14.10.2.28
Textiles 14.10.2.13, 14.10.2.16, 14.10.2.28
Texture, surface 4.3.2, 4.7
Thermal columns *see* Plumes
Thermal conductivity 3.2 to 3.3, 5.2.3.4, A.3.3
Thermal effects 18.4.3, 18.13.3.1, 18.17.5, 20.5.2
Thermal expansion 4.9, 4.20.2
 Definition 1.3.120, A.1.3.120
Thermal inertia 3.2.1, 3.3, 5.2.3.3, 16.3(c)
 Definition 1.3.121
Thermal injuries 20.8.2.3
Thermal properties, selected materials Table 3.2.1
Thermite 19.2.4, A.19.2.4
Thermocouples 21.5.9
Thermopiles 21.5.9
Thermoplastics 4.17.7.2
 Definition 1.3.122
 Melting of 4.8
Thermoset plastics
 Definition 1.3.123
 Ignition of 3.3.1
Thermostats 6.8.3
Thick and thin materials 3.3.1
Thresholds 4.2.2, 4.16.1.4
Tiles 3.6, 4.3.2, 4.16.1.4
Time, of incident 12.2.2
 Arson 19.4.1.2, 19.4.7
Time line
 Analysis 17.2, 18.17.1
 Definition 1.3.124
Time of burning 4.11
Time of incident
 Hard time 17.2
 Soft time (estimated or relative) 17.2
Time to flashover 3.5.3.2
Time to ignite Table 3.3.1

Time-delay fuses	6.6.1.3
Timers	
Appliance	21.5.9
Incendiary device	19.2.7.2
Tin	Table 4.8
Titanium	18.9
Title companies	11.6.8
Toasters	21.6.3
Toilets	7.8(g), A.7.8
Toluene	Table 3.3.4
Tools	10.3.4, 12.4.1
Topography, effect on wildland fires of	23.3.6
Total burns	15.9
Toxic gases	8.3.4.3, 10.2.7, 24.12
Toxic products, exposure of victims to	20.3.2 to 20.3.3, 20.5, 20.7.3.1.1, A.20.5.1
Toxicity, of building materials	5.2.3.5
Trade organizations	11.6.13
Trailers	4.18.1 to 4.18.2, 14.3.4, 19.2.2
Transformers	6.3.4, 21.5.2.2, 21.5.5, 23.7.3.1
Transmission, vehicle	22.5.5
Transportation, state department of	11.5.3.6
Transportation Department, U.S.	11.5.4.9
Transportation of evidence	14.8
Trash	Table 3.4, 15.6.1
Trash bags	Table 3.4
Treasurers, government	11.5.1.3, 11.5.2.4, 11.5.3.2
Treasury Department, U.S.	11.5.4.10
Trees	22.2.3, 23.2.2.5 to 23.2.2.7, 23.3.5, 23.4.4.2, 23.4.5, 23.7.3.1, 23.9.1
Truncated cone patterns	<i>see</i> Cone patterns
Truncated plume	4.2.1
Turbines	22.5.1.5
Turbochargers	22.5.1.5
Turbulence	4.3.2, 18.8.2.3 to 18.8.2.4, 18.9.3, A.18.8.2.4
Type S fuses	6.6.1.2
-U-	
Unconfined fires	3.5.2
Underground migration of fuel gases	18.8.3, Table 18.13.2
Understanding between parties	24.2
Underwriters Laboratories Inc. (UL)	14.10.4
Undetermined fire cause	16.2.4 to 16.2.5, 16.6.3, 16.7
Ungrounded conductors	6.3.2.1, 6.5, 6.7, 6.9.5, 6.10.2, 6.11.8, A.6.10.2
Uninhibited chemical chain reaction	3.1.1.4
United States government agencies	11.2.1, 11.5.4
Unknown fire cause	2.3.6
Upholstered furniture	
Flame height	3.5.5
Testing	14.10.2.14 to 14.10.2.15
Upper explosive limit (UEL)	18.8.2.1, 18.8.4
Upper gas layers	<i>see</i> Ceiling layers
Upper layer	<i>see</i> Ceiling layer
“U”-shaped fire patterns	4.2.1, 4.9, 4.17.4 to 4.17.5, 4.17.10
Utilities	
Explosion damage to	18.4.4
Origin determination and	15.4, 15.5.2, 15.6.2
Photographs	13.2.5.7, 15.6.2
Providers as information source	11.6.12
Status of	10.2.3
As wildland fire ignition source	23.7.3

-V-

Valves, fuel gas systems	7.5.3, 7.6.5
Vandalism	19.4.8.2.1
Vapor cloud explosions	18.11
Vapor density	18.8.2.2, A.18.8.2.2
Definition	1.3.126.1
Vapor explosions	<i>see</i> Gas/vapor explosions
Vaporizers	7.4.4
Vapors	4.19.2; <i>see also</i> Gas
Appliance installation in areas of flammable vapors	7.7.1.3, A.7.7.1.3
Confined	18.6.3
Definition	1.3.126
Ignitable, at fire scene	10.2.7
Ignition of	16.3
Initial fuel	16.4
Varnish blistering	Fig. 4.19.2
VCRs	21.6.14
Vector (definition)	1.3.127
Vector diagrams	15.2.3, A.15.2.3
Vehicle fires	<i>see</i> Motor vehicle fires
Vehicle identification number (VIN)	22.7.1
Vent (definition)	1.3.128
Ventilation	17.6.3
Barriers to	3.5.4.3
Building design and	5.2.2
Burning rate, effect on	4.5.3.2(c)
Definition	1.3.129
Effect on fire of	15.5.5
Occupancy type, effect of	5.2.4
Opening	3.5.4.1, 15.5.5
Pattern magnitude and location, effects on	B.3
Patterns generated by	4.2.2, A.4.2.2.1
Self-ignition and self-heating	3.3.5
System	24.12
Ventilation-controlled fire	<i>see</i> Fire
Venting	3.1.1.2, 7.7.2, 18.4.1.3 to 18.4.1.4, 18.5, 18.8.2.6
Definition	1.3.130
Verbal information	11.3.1
Victim injuries or deaths	<i>see</i> Casualties
Victim photographs	13.2.5.9
Video cameras	21.6.14
Videotapes	11.3.3, 11.6.14, 13.2, 13.2.4, 13.2.7.2, 21.4.4, 24.20
Death scene	20.2.2
Vinyl	4.5, 4.16.1.4
Visual information sources	11.3.3
Vital statistics, state department of	11.5.3.3
Volatile materials, as evidence	14.8.2.2
Volt (definition)	1.3.131
Voltage	6.2.4; <i>see also</i> Ohm’s Law
Drops	6.2.8 to 6.2.9, 6.2.13
“V”-shaped fire patterns	4.2.1, 4.9, 4.17.1, 4.17.3, 4.17.5, 23.4.1
-W-	
Wall studs, fire patterns	4.17.6, 4.20.2
Wallboard	4.5, 4.7, 4.12, A.4.12.1
Wallpaper	4.3.2, 4.5
Walls	4.12, 5.4.2, 17.6.1 to 17.6.2, 18.3.1 to 18.3.2, 18.8.2.2, 18.8.2.5, A.4.12.1, A.18.3.2, A.18.8.2.5; <i>see also</i> Wall studs
Damage inside	4.16.1.3
Effect on fire of	3.5.3
Finish rating	4.16.1.3

- Fire barrier 5.4.2
- Fire patterns on. 4.10, 4.16.1
- Manufactured homes 5.3.1.6.1
- Relative to fire. 3.5.4.3
- In vehicles 22.6
- Warnings**
- Disregard or ignorance of 8.4.1.3, 8.4.1.6 to 8.4.1.8
- Inadequate 9.6.4
- Waste** Table 3.4, 15.6.1
- Wool. Table 3.3.5
- Wastebaskets** 3.5.5, Table 3.4
- Water**
- Runoff 12.2.5
- Standing 10.2.5
- Water lines, use of.** 14.3.4.2.1
- Waterless cleaners.** 14.4.2
- Watts (W)** 6.2.14 to 6.2.15
- Definition 1.3.132
- Wax.** Table 4.8
- Weather conditions** 11.6.14, 12.2.3, 15.3.2
- Wildland fires 23.3.2, 23.3.7, 23.9.1
- Welding, arc.** 6.9.4.3, 6.9.5
- White pot metal.** 4.8.1, Table 4.8
- Wide “V” pattern** 4.2.1, 4.17.1
- Wildland fires** Chap. 23
- Animals, effect of 22.3.11
- Bibliography B.11
- Evidence 23.5.2.2, 23.5.2.4, 23.8
- Fire cause determination 23.7
- Fire spread, factors affecting 23.3, 23.5.2.3
- Fuels. 23.2, 23.3.5, 23.4.6.1
- Indicators 23.4
- Origin determination 23.5
- Initial area of investigation 23.5.1
- Search equipment 23.5.3
- Search techniques 23.5.2
- Safety considerations 23.9
- Security of area or point of origin 23.5.2.1, 23.6
- Sources of information. 23.10
- Suppression. 23.3.8
- Wildland–urban interface 23.3.10
- Windows.** 15.5.5, 17.6.2, 18.3.1
- Air conditioner units 21.6.10
- Broken 15.5.3
- Glass. 4.13, 15.5.3, 18.13.3.2, 18.13.3.4
- Open, as arson indicator 19.3.6
- Smoke deposits on 4.10
- Ventilation through 4.2.2, 18.8.2.6
- Windshield washer systems.** 22.5.8
- Wiring** 6.1; *see also* Conductors
- Alloying of. 4.8.2
- Energized, at fire scene 15.7.1
- As ignition source 6.9, 19.2.7.1, A.6.9.4.4
- Insulation *see* Insulation, electrical
- Witnesses**
- Authentication of evidence by 9.3.2.1
- Constitutional considerations and 9.3.4
- Expert. 9.7.2
- Definition 9.7.2
- To explosions 18.13.1.2
- Interviews of. 9.3.3 to 9.3.4, 11.4
- Investigators as 9.7
- Major fire investigation 24.18
- Photographs from viewpoint of 13.2.5.10
- Statements of 8.8.5, 9.3.2.2, 9.3.3
- Testimonial evidence by 9.3.2.3
- Wildland fires. 23.5.1.1 to 23.5.1.4
- Wood**
- Acrolein produced by 20.5.3
- Appliance housings 21.5.1.5
- Char 4.5.1
- Combustion products 3.6
- Fire patterns in. 4.3.4
- Flame temperature 4.8.1
- Flour 3.4
- Frame construction 5.3.1
- Fuel load. 3.4
- Ignition properties of Table 3.3.4
- As ignition source Table 3.3
- Manufactured wood structural elements 5.3.1.7
- Moisture in 4.5.2
- Smoke 3.6
- Specimens Table 3.3.1
- Time to ignition. 3.3.1
- Wall studs 4.17.6
- As wildland fire fuel. 22.2.3, 23.2.2.5 to 23.2.2.7, 23.3.5, 23.4.4.2, 23.4.5, 23.7.3.1
- Wool** 3.6
- Wool wastes.** Table 3.3.5
- Written information.** 11.3.2; *see also* Documentation
- X-**
- X-ray examination, fire victims** 20.3.1, 20.4.2, 20.6.7, A.20.4.2
- X-ray fluorescence** 14.10.2.5
- Z-**
- Zinc**
- Alloying of 4.8.2, 6.10.6.3, 21.5.1.1, A.6.10.6.3
- Melting of. Table 4.8.2, 21.5.1.3
- Oxidation of. 4.7, 21.5.1.1
- Zoning authorities** 15.9