



WOOD
CONSTRUCTION
CONNECTORS
2015-2016

C-C-2015

GENUINE
Simpson Strong-Tie® Connectors

(800) 999-5099
www.strongtie.com

Our Commitment





For nearly 60 years, Simpson Strong-Tie has steadfastly served the needs of its customers. During that time, our commitment to leading the construction industry in research and development, product testing and customer service has never wavered.

Today, that promise continues to be delivered worldwide – from our manufacturing facilities to the jobsite. Our commitment to maintaining the highest standards of quality and service can be seen when we help educate engineers on applications and specifications, or when we answer questions from contractors or building officials or help train them on a proper installation. We're there to ensure our dealers get their questions answered and to help their customers receive the best service possible.

You can expect Simpson Strong-Tie to be there to assist you. For our more than 2,000 employees, it's not about doing business, it's about our commitment to your success.



ALPHABETICAL INDEX

A Angle.....	207	✓ ECCQ/ECCOQ Column Cap.....	68	HGU Girder Hanger.....	102, 117, 234, 243
A34/A35 Anchor.....	206	✓ EG Hanger.....	104, 235, 242	HGUM Girder Hanger.....	176, 234, 243
ABA/ABU/ABW Post Base.....	56	EGQ Hanger.....	122, 235, 242	HGUQ Girder Truss Hanger.....	149, 234
ABL Anchor Bolt Locator.....	41	EPB Post Base.....	58	✓ HGUS Hanger.....	76-77, 101, 111,
ABS Anchor Bolt Stabilizer.....	41	EPB44PHDG Post Base.....	59	115-116, 146-147, 234, 237
AC/ACE Post Cap.....	66	EPB44T Post Base.....	59	HH Hanger.....	203
AHEP Adjustable Hip-End Purlin.....	165	EPCZ Post Cap.....	8, 67	HHB Hanger.....	84-85, 89, 103, 105, 235, 240
AM AnchorMate® Bolt Holder.....	41	EPS4Z Column Base.....	61	HHDQ Holddown.....	47
APG Architectural Products Group.....	228-232	ET-HP Epoxy.....	43	HHETA Truss Anchor.....	180-181
AT® Anchoring Adhesive.....	44	E-Z Base™ (FPBB44).....	219	HHGU Girder Hanger.....	102, 117, 234, 243
AT-XP® Anchoring Adhesive.....	43	E-Z Mender™ (FPBM44E).....	219	HHRC Hip Ridge Connector.....	98
B Hanger.....	84-85, 89-91, 120, 125,	E-Z Spike™ (FPBS44).....	219	HHSUQ Severe Skew Truss Hanger.....	150
.....	127-128, 130-132, 235, 240	F Hanger.....	100	HHUS Hanger.....	76-77, 111, 115-116,
✓ BA Hanger.....	84-85, 91, 120, 124-128, 235	FAP Foundation Plate.....	28	146-147, 234, 237
BC Cap/Base.....	65	FB Fence Bracket.....	219	✓ HIT Hanger.....	118-119, 126, 128-129, 235
BCS Cap/Base.....	65	FBR Fence Bracket.....	219	HL Strap Tie.....	194, 230-231
BP Bearing Plate.....	40, 228	FC Framing Clip.....	227	HL Heavy Angle.....	208, 232
BPS Bearing Plate.....	40	FGTR Girder Tiedown.....	183	HM Hurricane Tie.....	178-179
BT Brick Tie.....	227	FJA Anchor.....	28	HPA Purlin Anchor.....	54
CB Column Base.....	63, 230	FPBB44 (E-Z Base™).....	219	HRC Connector.....	98, 135
CBS Column Base.....	62	FPBM44E (E-Z Mender™).....	219	HRS Strap Tie.....	186-187
✓ CBSQ Column Base.....	62	FPBS44 (E-Z Spike™).....	219	HS Hurricane Tie.....	178-179, 196-198, 201
CC Column Cap.....	69, 230	FSA Anchor.....	28	HSCNW Coupler Nut.....	39
CCC Column Cap.....	71	FSC Strap.....	193	HSS Stud Shoe.....	223
CCCQ Column Cap.....	70	FSS Strap.....	109	✓ HST Strap.....	186-188, 230
CCCQM Column Cap.....	184-185	FTA Floor Tie Anchor.....	194	✓ HSUR/L Hanger.....	96, 135-136, 175, 234
CCO Column Cap.....	69	FWAZ Foundation Wall Angle.....	32	HSULC/HSURC Hanger.....	234
CCOB Column Cap.....	69	FWANZ Foundation Wall Angle.....	32	HT Strap Tie.....	194, 230-231
CCOS Column Cap.....	65	FWH Rigid Tie.....	221	HTC Heavy Truss Clip.....	169
✓ CCQ/CCOQ Column Cap.....	68	GA Angle.....	208	HTHGQ Truss Girder Hanger.....	158-159
CCQM Column Cap.....	184-185	GB Hanger.....	103, 105, 235, 240	HTHMQ Heavy Truss Hanger.....	163
CCT Column Cap.....	71	✓ GBC Gable Bracing.....	171	HTPZ Strap Tie.....	186-187
CCTQ Column Cap.....	70	GH Hanger.....	37, 235, 238	HTSM Twist Strap.....	182
CCTQM Column Cap.....	184-185	GLB Beam Seat.....	106	HTSQ Twist Strap.....	203
CF-R Form Angle/Shelf Bracket.....	220	GLBT Beam Seat.....	106	HTS Twist Strap.....	202
CHC Component Hoist Clip.....	172	GLS Hanger.....	104-105, 235, 239	HTT Tension Tie.....	49
CJT Concealed Tie.....	229	GLT Hanger.....	86, 89, 104-105, 235, 239	HTU Hanger.....	148-149, 234, 237
CMST Coiled Strap.....	189	GLTV Hanger.....	122, 127-128,	HU Hanger.....	74, 76-79, 81-82, 87-90,
CMSTC Coiled Strap.....	189	130-132, 235, 239	101, 105, 111-116, 175, 234, 236
CNW Coupler Nut.....	39	H Hurricane Ties.....	178-179, 196-198, 201	HUC Hanger.....	74, 76-79, 81-82,
Continuous Load Path	244	Hanger Options	233-243	101, 111-116, 175, 234
Corrosion Information	13-15	HB Hanger.....	120, 127-132, 235, 240	HUCITF Hanger.....	235
CPS Composite Standoff.....	232	HCA Hinge Connector.....	107	HUCQ Hanger.....	75, 77-79, 81-82,
CPTZ Concealed Post Tie.....	57-58	HCP Hip Corner Plate.....	97, 138	101, 111, 115-116, 234
CS Coiled Strap.....	189	HCSTR Strap.....	195	HUCTF Hanger.....	235
CSC Clip.....	109	HD Holddown.....	50	HUITF Hanger.....	127-128, 235, 242
CTS Compression Tension Strap.....	222	HDB Holddown.....	50	✓ HUS Hanger.....	76-79, 81-82, 87,
DETAL Truss Anchor.....	180-181	✓ HDC Holddown.....	48	89, 111, 115, 146
DJTZ Deck Tie.....	216	HDQ Holddown.....	47	HUSC Concealed Hanger.....	76-79, 81-82,
DPTZ Deck Tie.....	214	✓ HDU Holddown.....	46	115, 146, 234
DS Drywall Stop.....	220	HETA Truss Anchor.....	180-181	HUSCTF Hanger.....	235
DSC Drag Strut Connector.....	157	HETAL Truss Anchor.....	180-181	HUSTF Hanger.....	85
✓ DSP Double Stud Plate.....	205	HFN Hanger.....	100	HUTF Hanger.....	85, 235, 242
DTC Roof Truss Clip.....	169	HGA Gusset Angle.....	201	HW Hanger.....	86, 89, 91, 103,
DTT Deck Tension Tie.....	8, 46, 209	HGAM Gusset Angle.....	178-179	105, 121, 235, 241
DU/DHU/DHUTF Drywall Hangers.....	133, 134	HGB Hanger.....	103, 105, 235, 240	HWI Hanger.....	126-129, 131-132, 235
ECC/ECCU Column Cap.....	69	HGLB Beam Seat.....	106	HWU Hanger.....	86, 103, 121, 127-128,
ECCL Column Cap.....	71	HGLS Hanger.....	104-105, 235, 239	130-132, 235, 241
ECCLQ Column Cap.....	70	HGLT Hanger.....	86, 89, 104-105, 235, 239	ICFVL Ledger System.....	226
ECCLQM Column Cap.....	184, 185	HGLTV Hanger.....	122, 127-128,	✓ IS Insulation Supports.....	225
ECCLQMD Column Cap.....	184, 185	130-132, 235, 239	✓ ITS Hanger.....	118-119, 124-128, 235
✓ ECCQ/ECCOQ Column Cap.....	68	HGT Girder Tiedown.....	182, 204	✓ IUS Hanger.....	110, 112-113, 234
✓ EG Hanger.....	104, 235, 242	HGU Girder Hanger.....	102, 117, 234, 243	J/JP Jack Pier.....	221
EGQ Hanger.....	122, 235, 242	HGUM Girder Hanger.....	176, 234, 243		
EPB Post Base.....	58	HGUQ Girder Truss Hanger.....	149, 234		
EPB44PHDG Post Base.....	59	✓ HGUS Hanger.....	76-77, 101, 111,		
EPB44T Post Base.....	59	115-116, 146-147, 234, 237		
EPCZ Post Cap.....	8, 67	HH Hanger.....	203		
EPS4Z Column Base.....	61	HHB Hanger.....	84-85, 89, 103, 105, 235, 240		
ET-HP Epoxy.....	43	HHDQ Holddown.....	47		
E-Z Base™ (FPBB44).....	219	HHETA Truss Anchor.....	180-181		
E-Z Mender™ (FPBM44E).....	219	HHGU Girder Hanger.....	102, 117, 234, 243		
E-Z Spike™ (FPBS44).....	219	HHRC Hip Ridge Connector.....	98		
F Hanger.....	100	HHSUQ Severe Skew Truss Hanger.....	150		
FAP Foundation Plate.....	28	HHUS Hanger.....	76-77, 111, 115-116,		
FB Fence Bracket.....	219	146-147, 234, 237		
FBR Fence Bracket.....	219	✓ HIT Hanger.....	118-119, 126, 128-129, 235		
FC Framing Clip.....	227	HL Strap Tie.....	194, 230-231		
FGTR Girder Tiedown.....	183	HL Heavy Angle.....	208, 232		
FJA Anchor.....	28	HM Hurricane Tie.....	178-179		
FPBB44 (E-Z Base™).....	219	HPA Purlin Anchor.....	54		
FPBM44E (E-Z Mender™).....	219	HRC Connector.....	98, 135		
FPBS44 (E-Z Spike™).....	219	HRS Strap Tie.....	186-187		
FSA Anchor.....	28	HS Hurricane Tie.....	178-179, 196-198, 201		
FSC Strap.....	193	HSCNW Coupler Nut.....	39		
FSS Strap.....	109	HSS Stud Shoe.....	223		
FTA Floor Tie Anchor.....	194	✓ HST Strap.....	186-188, 230		
FWAZ Foundation Wall Angle.....	32	✓ HSUR/L Hanger.....	96, 135-136, 175, 234		
FWANZ Foundation Wall Angle.....	32	HSULC/HSURC Hanger.....	234		
FWH Rigid Tie.....	221	HT Strap Tie.....	194, 230-231		
GA Angle.....	208	HTC Heavy Truss Clip.....	169		
GB Hanger.....	103, 105, 235, 240	HTHGQ Truss Girder Hanger.....	158-159		
✓ GBC Gable Bracing.....	171	HTHMQ Heavy Truss Hanger.....	163		
GH Hanger.....	37, 235, 238	HTPZ Strap Tie.....	186-187		
GLB Beam Seat.....	106	HTSM Twist Strap.....	182		
GLBT Beam Seat.....	106	HTSQ Twist Strap.....	203		
GLS Hanger.....	104-105, 235, 239	HTS Twist Strap.....	202		
GLT Hanger.....	86, 89, 104-105, 235, 239	HTT Tension Tie.....	49		
GLTV Hanger.....	122, 127-128,	HTU Hanger.....	148-149, 234, 237		
.....	130-132, 235, 239	HU Hanger.....	74, 76-79, 81-82, 87-90,		
H Hurricane Ties.....	178-179, 196-198, 201	101, 105, 111-116, 175, 234, 236		
Hanger Options	233-243	HUC Hanger.....	74, 76-79, 81-82,		
HB Hanger.....	120, 127-132, 235, 240	101, 111-116, 175, 234		
HCA Hinge Connector.....	107	HUCITF Hanger.....	235		
HCP Hip Corner Plate.....	97, 138	HUCQ Hanger.....	75, 77-79, 81-82,		
HCSTR Strap.....	195	101, 111, 115-116, 234		
HD Holddown.....	50	HUCTF Hanger.....	235		
HDB Holddown.....	50	HUITF Hanger.....	127-128, 235, 242		
✓ HDC Holddown.....	48	✓ HUS Hanger.....	76-79, 81-82, 87,		
HDQ Holddown.....	47	89, 111, 115, 146		
✓ HDU Holddown.....	46	HUSC Concealed Hanger.....	76-79, 81-82,		
HETA Truss Anchor.....	180-181	115, 146, 234		
HETAL Truss Anchor.....	180-181	HUSCTF Hanger.....	235		
HFN Hanger.....	100	HUSTF Hanger.....	85		
HGA Gusset Angle.....	201	HUTF Hanger.....	85, 235, 242		
HGAM Gusset Angle.....	178-179	HW Hanger.....	86, 89, 91, 103,		
HGB Hanger.....	103, 105, 235, 240	105, 121, 235, 241		
HGLB Beam Seat.....	106	HWI Hanger.....	126-129, 131-132, 235		
HGLS Hanger.....	104-105, 235, 239	HWU Hanger.....	86, 103, 121, 127-128,		
HGLT Hanger.....	86, 89, 104-105, 235, 239	130-132, 235, 241		
HGLTV Hanger.....	122, 127-128,	ICFVL Ledger System.....	226		
.....	130-132, 235, 239	✓ IS Insulation Supports.....	225		
HGT Girder Tiedown.....	182, 204	✓ ITS Hanger.....	118-119, 124-128, 235		
		✓ IUS Hanger.....	110, 112-113, 234		



ALPHABETICAL INDEX

- JB** Hanger 84–85, 87, 90
JBA Hanger 8, 84–85
KBS1Z Knee-Brace Stabilizer 217
L Angle 208
L Strap Tie 194
LB Hanger 84–85, 87, 90, 235
LBAZ Hanger 8, 84–85, 235
LBP Bearing Plate 40
LBV Hangers 120, 124–130, 235, 240
LCB Column Base 63
LCC Lally Column Cap 65
LCE Post Cap 66
LEG Hanger 104, 230, 235, 242
LFTA Floor Tie Anchor 194
LGT Girder Tiedown 183, 204
LGU Girder Hanger 102, 117, 234, 243
LGUM Girder Hanger 176, 234, 243
LMAZ Mud sill Anchor 31
LPCZ Post Cap 66
LRUZ Rafter Hanger 92, 93
LS Angle 208
LSC Light Stair-Stringer Connector 215
LSSU Hanger 95, 137, 234
LSSUI Hanger 137
LSTA Strap Tie 186–187
LSTHD Holdown 51, 52
LSTI Strap Tie 186–187
LSU Hanger 95, 137, 234
LTA2 Truss Anchor 178–179
LTB Bridging 224
LTHJA Hanger 154, 234
LTHMA Hanger 151, 234
LTP Framing Anchor 206
LTS Twist Strap 202
LTT/LTTI Tension Tie 49
LU Hanger 74, 76–78, 81, 83, 234
LUC Hanger 74, 76–77, 81, 234
LUS Hanger 76–79, 81–82, 146–147, 234
MA Mud sill Anchor 31
MAB Mud sill Anchor 31
MASA Mud sill Anchor 29–30
MASAP Mud sill Anchor 29–30
MASB Mud sill Anchor 31
MBHA Masonry Hanger 178, 235, 243
MBHU Masonry Beam Hanger 177
MEG Hanger 104, 230, 235, 242
META Truss Anchor 180–181
Metric Conversion 19
MGT Girder Tiedown 182, 204
MGU Girder Hanger 102, 117, 234, 243
MIT Hanger 118–119, 124–130, 235
MIU Hanger 110, 112–114, 234
ML Angles 216
MP Mending Plate 227
MPAI Purlin Anchor 139
MSC Hanger 123, 235
MSCPT Hanger 164, 235
MST Strap Tie 186–188
MSTA Strap Tie 186–188
MSTAM Strap Tie 181
MSTC Strap Tie 186–188
MSTCB Strap Tie 193
MSTCM Straps Tie 181
MSTD Marriage Strap 48
MSTI Strap Tie 186–187
MTHMQ/MTHMQ-2 Hanger 156
MTS Twist Strap 202
MTSM Twist Strap 182
Multi-Ply Screws 140–142, 160
MUS Hanger 146, 234
Nails Bulk 23
Nail Conversion 22
NCA Nailless Bridging 224
NS/NSP Nail Stopper 222
OCB/OCC Cap/Bases 231
OHA Hangers 231
OHU Hangers 229
OL/OT/OHL/OHT Hangers 231
OU Hangers 231
OS/OHS Hangers 231
PA Holdown/Purlin Anchor 53–54
PAB Anchor Bolt 38
PAI Purlin Anchor 139
PB/PBS Post Base 60–61
PBV Post Base 232
PCT Purlin Cross Tie 195
PCZ Post Cap 8, 67
PF Hanger 94, 235
PFB/PFDB Hanger 94
PGT Pipe Grip Tie 218
PGT2A Pipe Grip Tie 218
PGT2E Pipe Grip Tie 218
PGTIC Pipe Grip Tie 218
PPBZ Post Base 64
PS Strap 186–187
PSCL/PSCA Sheathing Clip 220
PSPNZ Protective Plate 222
Quik Drive® 24–25, 160
RBC Roof Boundary Clip 207
RC Ripper Clip 132
RCWB Wall Bracing 225
RFB Retrofit Bolt 39
RPBZ Retrofit Post Base 8, 55
RPS Strap Tie 223
RR Connector 220
RSP Stud Plate Tie 205
RTA/RTB/RTC/RTC2Z/RTF/RTR/RTT/RTU Rigid Tie® 221
RTC Post Cap 66, 221
SA Strap Connector 190
SB Anchor Bolts 33–34
SBV Shelf Bracket 220
SCNR Ring-Shank Connector Nails 23
SD Connector Screw 27
SDS Heavy-Duty Connector Screw 26–27
SDW Wood Screw 140–142
SDWC Truss Screw 199–200
SDWF Floor-to-Floor Screw 191–192
SDWS Log Screw 210–214
SDWHSS Timber-Hex Screw 210–214
SET® Anchoring Adhesive 44
SET-XP® Anchoring Adhesive 43
SM1 Strap Holder 41
Software and Apps 20–21
SP/SPH Stud Plate Tie 205
Special Order Plates 228
SS Stud Shoe 223
SSP Single Stud Plate 205
SSTB Anchor Bolt 35–37
ST Strap Tie 186–187
STC Roof Truss Clip 169
STCT Roof Truss Clip 169
STHD Holdown 51–52
StrapMate® Strap Holder 41
Strong-Bolt® 2 Wedge Anchor 43
SUR/SUL Hanger 96, 135–136, 234
SURC/SULC Hanger 234
T Strap Tie 194
TA Staircase Angle 216
TB Tension Bridging 224
TB Screw 25
TBD Truss Brace 166
TBE Truss Enhancer 167–168
TC Truss Connector 168
THA Hanger 99, 143, 235
THAC Hanger 99, 143, 235
THAI Hanger 117, 235
THAR/L Truss Hanger 99, 151, 235
THASR/L Truss Hanger 144, 235
THD Titen HD® Screw Anchor 44
THGB/THGBH Hanger 162, 234, 238
THGBV/THGBHV Hanger 160–161, 234, 238
THGQ/THGQH Hanger 158–159, 234, 238
THGW Hanger 162
THGWV Hanger 160–161
THJA Hanger 155, 234
THJM Hanger 157
THJU Hanger 152, 234, 237
TITEN® Screw 173
TJC Truss Connector 8, 153
TORQ-CUT™ Anchor 43
TP/TPA Tie Plate 227
TS Twist Strap 190
TSBR Truss Spacer 166
TSF Truss Spacer 165
TSP Stud Plate Tie 196–198, 205
TSS Truss Seat 180–181
TWB Wall Bracing 225
U Hanger 74, 76–79, 81–83, 111–112, 114–115, 234, 236
UFP Foundation Anchor 28
VB Knee Brace 198
VGT Variable Girder Tiedown 183, 204
VPA Connector 97, 138
VTCR Valley Truss Clip 170
W Hanger 86–87, 90–91, 121, 125, 145, 235, 241
WB/WBC Wall Bracing 225
WEDGE-ALL® Wedge Anchor 44
WI Hanger 125–126, 235
WM Hanger 86, 103, 121, 145, 173–174, 235–236
WMI Hanger 173–174, 235–236
WMU Hanger 86, 103, 121, 173–174, 236
WNP Hanger 86–87, 89–91, 235, 241
WNPU Hanger 235, 241
WP Hanger 103, 121, 124–126, 129–130, 145, 235, 241
WPI Hanger 126–131, 235
WPU Hanger 86, 103, 121, 124, 127–130, 235, 241
WSNTL Screw 25, 160
WT Wedge Form Tie 40
Z Clip 208

SUBJECT INDEX

FASTENERS

Nails (Bulk and Collated).....	22–23
Fastener Types.....	22
Fastening Identification.....	23
Screws.....	22, 26–27, 140–142, 199–200, 210–214
Quik Drive® Systems.....	24–25, 160
Concrete/CMU.....	173

CONCRETE CONNECTORS

Anchor Adhesives.....	43–44
Anchor Bolts.....	33–39
Anchor Bolt Holders.....	41
Beam Seats.....	106
Bearing Plates.....	40, 228
Column Caps.....	184–185
Coupler Nuts.....	39
Foundation Anchors.....	28
Hangers.....	37, 173–178
Holdowns.....	51–53
Hurricane Ties.....	178–179
ICF.....	226
Ledger.....	226
Mud sill Anchors.....	29–31
Purlin Anchors.....	54
Truss Anchors.....	178–181
Truss Seats.....	180–181
Wedge Form Ties.....	40

HOLDOWNS & TENSION TIES

Floor Tie Anchors.....	193–194
Holdowns.....	46–53

CAPS & BASES

Post/Column Caps and Bases.....	55–71
---------------------------------	-------

SOLID SAWN LUMBER CONNECTORS

Adjustable Hangers.....	95–99
Concealed Joist Ties.....	229
Face Mount Hangers.....	74–83, 230–231
Rafter Hanger.....	92–93
Rough Lumber Face Mount Hangers.....	83
Sloped/Skewed Connectors.....	95–96, 98
Top Flange Hangers.....	84–91

ENGINEERED WOOD & STRUCTURAL

COMPOSITE LUMBER CONNECTORS

Adjustable Hangers.....	117, 135–138
Concealed Joist Ties.....	229
Face Mount Hangers.....	110–116
General Installation Info.....	108–109
Purlin Anchors.....	139
SDW/Multi-Ply Members.....	140–142
Sloped/Skewed Connectors.....	135–138
Top Flange Hangers.....	118–132

GLULAM BEAM CONNECTORS

Concealed Joist Ties.....	229
Cross Tie Connectors.....	195
Face Mount Hangers.....	101–102
Hinge Connectors.....	107
Top Flange Hangers.....	103–105

PLATED TRUSS/TRUSS CONNECTORS

Adjustable Hangers.....	143–144, 151
Bridging/Spacers/Braces.....	165–166
Special Order Plates.....	228
Face Mount Hangers.....	146–150
Gable End.....	171
Girder Hangers.....	149, 158–162
Girder Tiedowns.....	182–183, 204
Multi-Member Hangers.....	151–157, 163–164
SDW/Multi-Ply Members.....	140–142
Top Flange Hangers.....	145
Truss Bearing Enhancers.....	167–168
Truss Clips.....	169–170

MASONRY CONNECTORS

Brick Ties.....	227
Column Caps.....	184–185
Fastener.....	173
Hangers.....	173–178
Hurricane Connectors.....	178–179
Straps.....	181–182
Truss Anchors.....	178–181

STRAPS & TIES

Angles & Clips.....	206–208
Hinge Connector Straps.....	107
Hurricane Ties.....	196–198, 201
Straps.....	186–190, 193, 222–223

DECKS & FENCES

Angles.....	216
Deck Post Connectors.....	209, 214
Fence Products.....	218–219
Joist Tie.....	216
Staircase Angle.....	216

MISCELLANEOUS

Brick Ties.....	227
Bridging.....	224
Compression Tension Straps.....	222
Custom Steel Plates.....	228
Drywall Stops.....	220
Framing Clips.....	227
Floor Beam Leveler.....	221
Hip Connectors.....	97–98, 135, 138
Insulation Supports.....	225
Knee Brace.....	198
Mending Plates.....	227
Nail Stoppers.....	222
Panel Sheathing Clips.....	220
Ridge Rafter Connector.....	220
Rigid Ties.....	221
Shelf Brackets.....	220
Stud Shoes.....	223
T & L Strap Ties.....	194
Tie Plates.....	227
Variable Pitch Connectors.....	97, 138
Wall Bracing.....	225

ARCHITECTURAL PRODUCTS

GROUP (ORNAMENTAL).....	228–232
-------------------------	---------

HANGER OPTIONS.....	233–243
---------------------	---------

POST CAPACITIES.....	245–246
----------------------	---------

KEEP THIS CATALOG – IT IS VALID FOR TWO YEARS



Simpson Strong-Tie publishes the *Wood Construction Connectors* catalog every two years. In an effort to continue to provide our customers with current information on our ever-expanding product line, we publish an addendum on years we don't print a catalog. The addendums contain new product information, updated testing information and any other information needed to keep our customers up to date with our product line. As always, please be sure to visit our website regularly for updates that occur throughout the year – www.strongtie.com.

INTRODUCTION

For nearly 60 years, Simpson Strong-Tie has focused on creating structural products that help people build safer and stronger homes and buildings. A leader in structural systems research and technology, Simpson Strong-Tie is one of the largest suppliers of structural building products in the world. The Simpson Strong-Tie commitment to product development, engineering, testing and training is evident in the consistent quality and delivery of its products and services.

For more information, visit the company's Web site at www.strongtie.com.

The Simpson Strong-Tie Company Inc.

"No Equal" pledge includes:

- Quality products value-engineered for the lowest installed cost at the highest rated performance levels
- Most thoroughly tested and evaluated products in the industry
- Strategically located manufacturing and warehouse facilities
- National code agency listings
- Largest number of patented connectors in the industry
- Global locations with an international sales team
- In-house R&D and tool and die professionals
- In-house product testing and quality control engineers
- Support of industry groups including AISI, AITC, ASTM, ASCE, AWC, AWPA, ACI, AISC, CSI, CFSEI, ICFA, NBMDA, NLBMDA, SDI, SETMA, SFIA, STAFDA, SREA, NFBA, TPI, WDSC, WIJMA, WTCA and local engineering groups.

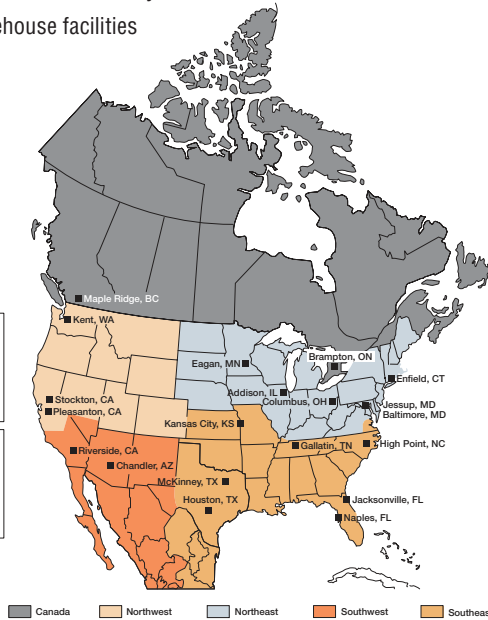

THE SIMPSON STRONG-TIE QUALITY POLICY

We help people build safer structures economically. We do this by designing, engineering and manufacturing "No Equal" structural connectors and other related products that meet or exceed our customers' needs and expectations. Everyone is responsible for product quality and is committed to ensuring the effectiveness of the Quality Management System.

Karen Colonias
Chief Executive Officer

GETTING FAST TECHNICAL SUPPORT

When you call for engineering technical support, we can help you quickly if you have the following information at hand. This will help us to serve you promptly and efficiently.

- Which Simpson Strong-Tie® catalog are you using? (See the front cover for the catalog number)
- Which Simpson Strong-Tie product are you using?
- What is your load requirement?
- What is the carried member's width and height?
- What is the supporting member's width and height?
- What is the carried and supporting members' material and application?



WE ARE ISO 9001-2008 REGISTERED

Simpson Strong-Tie is an ISO 9001-2008 registered company. ISO 9001-2008 is an internationally-recognized quality assurance system which lets our domestic and international customers know that they can count on the consistent quality of Simpson Strong-Tie® products and services.

800-999-5099 | www.strongtie.com

CONNECTOR SELECTION KEY

Products are divided into fifteen general categories, identified by tabs along the page's outer edge.

Fasteners & Quik Drive® Systems

22-27 ▶

Concrete Connectors & Anchors

28-44 ▶

Holdowns & Tension Ties

45-54 ▶

Caps & Bases

55-71 ▶

Solid Sawn Joist Hangers

74-100 ▶

Glulam Beam Connectors

101-107 ▶

Engineered Wood & Structural Composite Lumber Connectors

108-142 ▶

Plated Truss Connectors

143-172 ▶

Masonry Connectors

173-185 ▶

Straps & Ties

186-208 ▶

Decks & Fences

209-219 ▶

Miscellaneous

220-227 ▶

Architectural Products Group

228-232 ▶

Hanger Options

233-243 ▶

NEW PRODUCTS FOR 2015

**PCZ/EPCZ Post Caps**

The new PCZ/EPCZ post caps enable one size to accommodate several post sizes. With post and header flanges now in-line, one PCZ or EPCZ model can accommodate several 4x or 6x post sizes for a variety of lighter-duty applications, including patio covers, trellises and interior framing.

See page 67 for more information.

**DTT1Z Deck Tension Tie**

The DTT1Z deck tension tie was designed to satisfy a new 2015 IRC provision that allows for four 750 lbs. lateral connections, instead of connecting to the floor joists in the house. The DTT1Z attaches with a $\frac{3}{8}$ " screw fastened into wall plates or studs, thereby eliminating the need to access the joists within the house.

See pages 46 and 209 for more information.

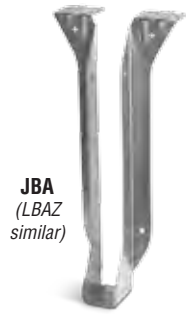

JBA
(LBAZ
similar)

JBA and LBAZ Top-Flange Hangers

The next-generation version of the JB and LB top-flange hangers, respectively, the JBA and LBAZ provide higher loads to accommodate 2x10, 2x12 and 2x14 members. New nail locations allow for use with nailers. The 14 gauge LBAZ may be welded to steel headers.

See page 84 for more information.

**RPBZ Retrofit Post Base**

The new RPBZ retrofit post base serves as reinforcement for many post applications, such as braced patio covers, car ports, trellises and other structures. RPBZ can be installed in conjunction with the CPS composite plastic standoff to meet a 1" post standoff code requirement. A single RPBZ can be installed on a post that is flush to a corner, and two RPBZs can be installed at away from edge conditions to fortify the post base connection to resist both wind and seismic forces.

See page 55 for more information.

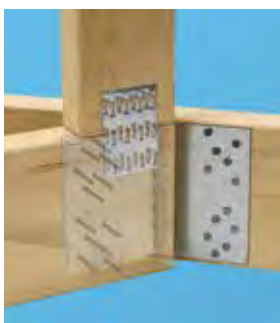
**TJC57 Jack Truss Connector**

The new TJC57 extends this line of versatile connectors for jack trusses. Adjustable from 0 to 85 degrees (*shipped with 67.5 degree bend*). Nail hole locations are placed for easy installation.

See page 153 for more information.



DISCONTINUED PRODUCTS

Products that will be discontinued in 2015

Simpson Strong-Tie is dedicated to continuously expanding our line of structural connectors with innovative new products that address the changing needs of our customers. As new connectors are introduced that improve upon older designs, it becomes necessary to discontinue the old versions in the name of efficiency and product-line simplicity.













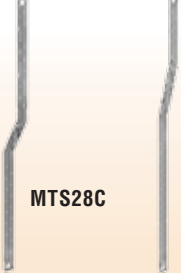

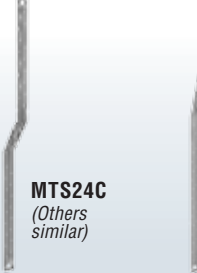









The table below lists products that are no longer included in the *Wood Construction Connectors* catalog as well as the products recommended to replace them. While technical information for discontinued products will be maintained on our website for a number of months, Simpson Strong-Tie asks that our customers begin to substitute the replacement products shown below in their designs and inventories. While it is hard to say when they will no longer be available from our distribution partners, production of some of these connectors ended in 2014 and others will be phased out of production in 2015. Verify with Designer prior to substituting replacement product for specified product.

For the most current information on discontinued products visit www.strongtie.com/discontinued. If you have questions about any of the products shown below, please call (800) 999-5099 for assistance.

DISCONTINUED PRODUCT		REPLACEMENT PRODUCT (C-C-2015 Page #)	
HANGERS			
 <p>JB210 (JB212 and JB214 similar)</p>	<p>JB210 (Limited availability)</p>	➔	<p>JB210A (page 84)</p>
	<p>JB212 (Limited availability)</p>	➔	<p>JB212A (page 84)</p>
	<p>JB214 (Limited availability)</p>	➔	<p>JB214A (page 84)</p>
 <p>LB210 (LB212 and LB214 similar)</p>	<p>LB210 (Limited availability)</p>	➔	<p>LB210AZ (page 84)</p>
	<p>LB212 (Limited availability)</p>	➔	<p>LB212AZ (page 84)</p>
	<p>LB214 (Limited availability)</p>	➔	<p>LB214AZ (page 84)</p>
 <p>ITS2.56/11.25 (Others imilar)</p>  <p>IUS2.56/9.25</p>  <p>HIT3518, 3520, 326, 426</p>	<p>ITS1.56/9.5/11.88 (Available until 12/31/2015)</p>	➔	N/A
	<p>ITS2.56/9.25 (Available until 12/31/2015)</p>	➔	<p>LBV2.56/9.25 (page 125)</p>
	<p>ITS2.56/11.25 (No availability)</p>	➔	<p>LBV2.56/11.25 (page 126)</p>
	<p>ITS3.56/9.25/11.25 (Available until 12/31/2015)</p>	➔	<p>LBV3.56/9.25/11.25 (page 127)</p>
	<p>IUS2.56/9.25 (No availability)</p>	➔	<p>U310 (page 78)</p>
	<p>HIT3518, 3520, 326, 426 (No availability)</p>	➔	<p>MIT or B Series (page 125)</p>
			 <p>LBV2.56/9.25 (Others similar)</p>  <p>U310</p>  <p>MIT Series</p>  <p>B Series</p>

C-C-2015 © 2015 SIMPSON STRONG-TIE COMPANY INC. PRINTED 12/14

DISCONTINUED PRODUCTS

DISCONTINUED PRODUCT		REPLACEMENT PRODUCT (C-C-2015 Page #)	
RIGID TIE®			
 RTC24	RTC24 <i>(Limited availability)</i>		RTC2Z <i>(page 221)</i>
TWIST STRAP			
 MTS28C HTS28	MTS28C <i>(Available until 12/31/2015)</i>		MTS24C, ... 30C <i>(page 202)</i>
	HTS28 <i>(Limited availability)</i>		HTS24, ... 30 <i>(page 202)</i>
			 MTS24C HTS30 <i>(Others similar)</i> <i>(Others similar)</i>
POST CAPS & BASES			
 AC4R <i>(AC6R similar)</i>	AC4R, AC6R <i>(Limited availability)</i>		AC4RZ, AC6RZ <i>(page 66)</i>
	PBS44R, 66R <i>(Limited availability)</i>		CB44R, 66R <i>(page 63)</i>
	PC44, 44-16; 46, 46-16; 48, 48-16 <i>(Available until 12/31/2015)</i>		PC4Z <i>(page 67)</i>
	PC44R, 44R-16; 46R, 46R-16 <i>(Available until 12/31/2015)</i>		PC4RZ <i>(page 67)</i>
	PC64, 64-16; 66, 66-16; 68 <i>(Available until 12/31/2015)</i>		PC6Z <i>(page 67)</i>
	PC64R, 64R-16; 66R, 66R-16 <i>(Available until 12/31/2015)</i>		PC6RZ <i>(page 67)</i>
	PC84, 86, 88 <i>(Available until 12/31/2015)</i>		PC8Z <i>(page 67)</i>
	PC88R <i>(Available until 12/31/2015)</i>		PC8RZ <i>(page 67)</i>
	EPC44, 44-16; 46, 46-16; 48, 48-16 <i>(Available until 12/31/2015)</i>		EPC4Z <i>(page 67)</i>
	EPC44R, 44R-16; 46R, 46R-16 <i>(Available until 12/31/2015)</i>		EPC4RZ <i>(page 67)</i>
	EPC64, 64-16; 66, 66-16; 68 <i>(Available until 12/31/2015)</i>		EPC6Z <i>(page 67)</i>
	EPC64R, 64R-16; 66R, 66R-16 <i>(Available until 12/31/2015)</i>		EPC6RZ <i>(page 67)</i>
	EPC84, 86, 88 <i>(Available until 12/31/2015)</i>		EPC8Z <i>(page 67)</i>
	EPC88R <i>(Available until 12/31/2015)</i>		EPC8RZ <i>(page 67)</i>
 AC4RZ <i>(AC6RZ similar)</i>			 CB66R <i>(CB44R similar)</i>
 PC4Z <i>(Others similar)</i>			 EPC6Z <i>(Others similar)</i>

HOW TO USE THIS CATALOG

NEW PRODUCTS

New products are shown with the  symbol. There are also many new sizes within existing model series.

CHANGES IN RED

Significant changes from last year's catalog are indicated in red.



VALUE ENGINEERED

This icon indicates a product that is preferable to similar connectors because of a) easier installation, b) higher loads, c) lower installed cost, or a combination of these features.



EXTRA CORROSION PROTECTION

This icon identifies products that are available with additional corrosion protection (*ZMAX[®], hot-dip galvanized, stainless steel or double-barrier coating*). Other products may also be available with additional protection, contact Simpson Strong-Tie for options. The end of the product name will indicate what type of extra corrosion protection is provided (*Z = ZMAX, HDG = hot-dip galvanized or SS = stainless steel*). See pages 13-15 for information on corrosion, and visit our website www.strongtie.com/info for more technical information on this topic.



STRONG-DRIVE[®] SD CONNECTOR SCREW COMPATIBLE

This icon identifies products approved for installation with the Simpson Strong-Tie[®] Strong-Drive[®] SD Connector screw. See page 27 for more information.

HOW WE DETERMINE ALLOWABLE LOADS

Allowable loads in this catalog are determined by calculations and test criteria established by industry, such as ICC-ES Acceptance Criteria, IAPMO UES Evaluation Criteria and ASTM test standards.

Connectors are typically evaluated in accordance with ICC-ES AC13 – Acceptance Criteria for Joist Hangers and Similar Devices. Evaluation is based on a minimum of three static load tests in wood assemblies. The published allowable load is the lower of the tested ultimate with a safety factor of 3, load at 1/8" deflection or the NDS fastener calculation limits.

Holdowns and tension ties are tested in accordance with ICC-ES AC155 – Acceptance Criteria for Hold-Downs (Tie-Downs) Attached to Wood Members. Allowable loads are based on the lower of three static load tests with a safety factor, deflection limits or NDS fastener calculation limits. Static load tests include holddown testing on steel jigs and wood assembly tests.

Cast-in-place concrete products are tested in accordance with ICC-ES AC398 – Cast-in-Place, Cold-Formed Steel Connectors in Concrete for Light-frame Construction or AC399 – Cast-in-Place Proprietary Bolts in Concrete for Light-Frame Construction. Threaded fasteners are evaluated per AC233 – Alternate Dowel-Type Threaded Fasteners.

Where a test standard is unavailable, testing is conducted per sound engineering principles. Some tests include only portions of a product, such as purlin anchor tests only the embedded hook is tested, not the nailed or bolted section of the strap, which is calculated. Testing to determine allowable loads in this catalog is not done on connection systems in buildings. Testing is conducted under the supervision of an independent laboratory.

For detailed information regarding how Simpson Strong-Tie tests specific products, contact Simpson Strong-Tie.

CATALOG DEFINITION:

Deflection: The distance a point moves when a load is applied.

Model No.	W	L	H	Nails	Allowable Loads			Code Ref.
					Uplift		Download	
					Non-Cracked	Cracked		
Wind and Seismic Design Category A & B								
EPB44A	3 3/16	3	2 3/8	8-16d	1120	785	2670	I28
EPB44	3 3/16	3 1/4	2 5/16	8-16d	1035	725	3465	
EPB46	5 1/2	3 3/16	3	12-16d	1035	725	3465	
EPB66	5 1/2	5 1/2	3	12-16d	1035	725	3465	
Seismic Design Category C-F								
EPB44A	3 3/16	3	2 3/8	8-16d	940	660	2670	I28
EPB44	3 3/16	3 1/4	2 5/16	8-16d	870	605	3465	
EPB46	5 1/2	3 3/16	3	12-16d	870	605	3465	
EPB66	5 1/2	5 1/2	3	12-16d	870	605	3465	

Model No.: This is the Simpson Strong-Tie product name.

Nails: This shows the fastener quantity and type required to achieve the table loads.

Allowable Design Loads: The maximum load that a connection is designed to provide. There may be multiple design loads acting in different directions (*up, down, lateral, perpendicular, etc.*) imposed on a connection.

Code Ref: See page 12 for the Code Reference Key Chart, to determine which code reports include this product.

Wind or Seismic: Some cast-in-place concrete products have different load ratings based on wind or seismic design category.

Dimensions W, L, H: This shows the product dimensions (*width, length and height in this case*) referenced in the product drawing.

NAILS: 16d = 0.162" dia. x 3 1/2" long. See pages 22-23 for other nail sizes and information.

Throughout this catalog a footnote will typically be provided indicating the required nail diameter and length.

All installations should be designed in accordance with the allowable load values set forth in this catalog.

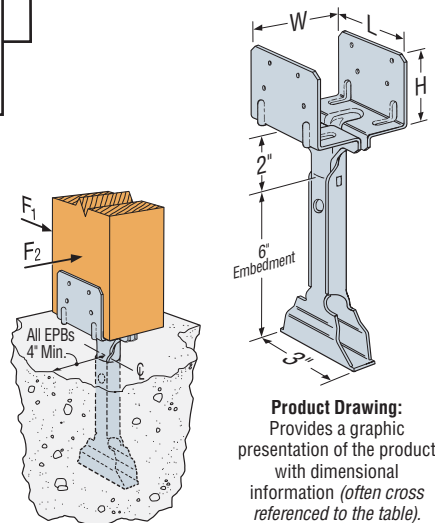

Product Drawing: Provides a graphic presentation of the product with dimensional information (*often cross referenced to the table*).

CODE REPORTS

Code Reference Column in Load Tables

The alpha-numeric "Code Reference numbers" that appear in the "Code Reference" column in load tables throughout this catalog are intended to identify products listed in evaluation agency reports, typically called "code reports", and the specific reports that cover them. The letter designates which evaluation agency from which the report was obtained. The Code reference column, used in conjunction with the chart at right, indicates which code listing applies to a product. The reference numbers also clearly identify:

- Products submitted for evaluation report listing (160)
- Products with no evaluation report listing (170)
- Products not submitted because they have no load rating and an evaluation report listing is not necessary (180)
- Products that meet prescriptive or conventional construction code requirements (190)
- Product is tested per code; testing is not required (200)

Where a model has been submitted for listing (160) or does not have an evaluation report listing (170), Simpson Strong-Tie can supply complete test data to support our published loads. Please contact us for a copy of our product test documentation at (800) 999-5099. Product acceptance may be obtained through the Alternate Methods and Materials section of the applicable building code.

Some loads and applications may not be covered in the code report and specific reductions and restrictions may be required by other product evaluation agencies. Visit www.strongtie.com or visit the product evaluation agencies' web sites for the current evaluation reports.

Simpson Strong-Tie® products are listed by several product evaluation agencies. Agencies that list our products include ICC-ES; IAPMO UES; UL, FM, the City of Los Angeles, California; and State of Florida.

Simpson Strong-Tie currently maintains more than 60 ICC-ES ESR and IAPMO UES ER reports evaluated to the 2006/2009/2012 IBC and IRC. We continue to submit product information to ICC-ES in order to update reports or receive additional reports for products in compliance with the latest codes.

To quickly determine which of our stamped and welded connector products are listed in ESR reports, we have obtained ICC-ES ESR-2523 index report. This report is a reference document to other ESR reports held by Simpson Strong-Tie and will be updated frequently by ICC-ES as new stamped and welded connector evaluation services reports are issued. Please visit www.strongtie.com for the latest information or contact ICC Evaluation Service at www.icc-es.org.

IAPMO Uniform Evaluation Service has been evaluating products for more than 80 years and has the same ANSI accreditation as ICC Evaluation Service for evaluating structural building products to the building codes. IAPMO UES began evaluating structural building products in 2004, utilizing licensed structural engineers to perform quality reviews. To quickly determine which of our stamped and welded connector products are listed in ER reports, we have obtained IAPMO UES ER-102 index report, which will be updated frequently as products are added to ERs. Please visit www.strongtie.com for the latest information or contact IAPMO Uniform Evaluation Service at www.iapmoes.org.

In November 2010, the California Division of the State Architect, issued a revised IR 23-1. The revised Interpretation of Regulation (IR) addresses and clarifies issues relating to Pre-fabricated Wood Construction Connectors. IR 23-1 defines the Purpose and Scope and clarifies Listing Requirements, Acceptable Load Capacities, Design Requirements, Installation Requirements Connector Fabrication (which addresses corrosion resistant material and/or coatings), and testing requirements. Also IRA-5, updated in October 2012, addresses product and evaluation report acceptance. Please contact the DSA at www.dsa.dgs.ca.gov/Publications/default.htm for more information.

On October 1, 2003, the State of Florida's Statewide Product Approval System became effective. The purpose of this system is to provide a single product evaluation and approval system that applies statewide to operate in coordination with the Florida Building Code. This Florida product evaluation and approval system is governed by Florida Statutes, Chapter 553, Section 553.842. Since this law specifies that the product approval system is to apply statewide, Notice of Acceptance is no longer necessary where a product has a statewide approval that is applicable in the High Velocity Hurricane Zone (HVHZ) and is installed in accordance with its conditions of use.

To access pertinent code reports related to Simpson Strong-Tie® products, you can access our Code Report Finder Software at www.strongtie.com/software.

CODE REFERENCE KEY CHART

AGENCY	CODE LISTING	CODE REF.	AGENCY	CODE LISTING	CODE REF.
ICC-ES ESR	ESR-1161	I1	IAPMO UES ER	ER-112	IP1
	ESR-2203	I2		ER-130	IP2
	ESR-1622	I3		ER-143	IP3
	ESR-2105	I4		ER-192	IP4
	ESR-2236	I5		ER-262	IP5
	ESR-2330	I6		ER-280	IP6
	ESR-2549	I7	State of Florida	FL10849	F1
	ESR-2551	I8		FL10852	F2
	ESR-2552	I9		FL10854	F3
	ESR-2553	I10		FL11496	F4
	ESR-2554	I11		FL10441	F5
	ESR-2604	I12		FL10655	F6
	ESR-2605	I13		FL10447	F7
	ESR-2606	I14		FL10531	F8
	ESR-2607	I15		FL10856	F9
	ESR-2608	I16		FL10444	F10
	ESR-2613	I17		FL10860	F11
	ESR-2614	I18		FL10861	F12
	ESR-2615	I19		FL10446	F13
	ESR-2616	I20		FL15895	F14
	ESR-2877	I21		FL10864	F15
	ESR-2555	I22		FL10456	F16
	ESR-2611	I23		FL10865	F17
	ESR-3046	I24		FL10667	F18
	ESR-2920	I25		FL10866	F19
	ESR-2320	I26		FL9589	F20
	ESR-3096	I27		FL11166	F21
ESR-3050	I28	FL11169		F22	
City of Los Angeles, California	RR 25711	L1		FL11468	F23
	RR 25712	L2		FL13904	F24
	RR 25713	L3		FL11478	F25
	RR 25714	L4		FL11470	F26
	RR 25910	L5		FL11473	F27
	RR 25718	L6	FL12708	F28	
	RR 25719	L7	FL13326	F29	
	RR 25720	L8	FL13628	F30	
	RR 25725	L9	FL14101	F31	
	RR 25726	L10	FL13975	F32	
	RR 25800	L11	FL14571	F33	
	RR 25801	L12	FL15957	F34	
	RR 25462	L13	FL2355	F35	
	RR 25803	L14	Submitted for Listing	Call us for Status and Test Data	160
	RR 25804	L15			
	RR 25806	L16			
	RR 25807	L17	No Code Listing	Call us for Test Data	170
	RR 25814	L18			
	RR 25818	L19			
	RR 25827	L20	No Load Rating	—	180
	RR 25828	L21			
	RR 25851	L22			
	RR25906	L23			
	RR25907	L24			
	RR25952	L25			
	RR25962	L26	Prescriptive Code	—	190
	RR25985	L27			

* Because code reports can be issued throughout the year, we encourage the user to visit www.strongtie.com, www.icc-es.org, www.iapmoes.org, www.ladbs.org, www.dsa.dgs.ca.gov, and www.floridabuilding.org for the most current information, call Simpson Strong-Tie at 800-999-5099, or contact the code agency directly.

CORROSION INFORMATION

Understanding the Corrosion Issue

Many environments and materials can cause corrosion including ocean salt air, fire-retardants, fumes, fertilizers, preservative-treated wood, de-icing salts, dissimilar metals and more. Metal connectors, fasteners and anchors could corrode and lose load-carrying capacity when installed in corrosive environments or when installed in contact with corrosive materials.

The many variables present in a building environment make it impossible to accurately predict if, or when, corrosion will begin or reach a critical level. This relative uncertainty makes it crucial that specifiers and users are knowledgeable of the potential risks and select a product suitable for the intended use. It is also prudent that regular maintenance and periodic inspections are performed especially for outdoor applications.

It is common to see some corrosion in outdoor applications. Even stainless steel can corrode. The presence of some corrosion does not mean that load capacity has been affected or that failure is imminent. If significant corrosion is apparent or suspected, then the wood, fasteners and connectors should be inspected by a qualified engineer or qualified inspector. Replacement of affected components may be appropriate.

Some wood-preservative chemicals and fire retardant chemicals and retentions pose increased corrosion potential and are more corrosive to steel connectors and fasteners than others. Testing by Simpson Strong-Tie has shown that ACQ-Type D is more corrosive than Copper Azole Type C, Micronized Copper Azole, and CCA-C. At the same time, others have shown that the inorganic boron treatment chemicals, specifically SBX-DOT, is less corrosive than CCA-C.

Due to the many different chemical treatment formulations, chemical retention levels, moisture conditions and regional formulation variants, selection of fasteners has become a complex task. We have attempted to provide basic knowledge on the subject here, but it is important to fully educate yourself by reviewing our technical bulletins on the topic (www.strongtie.com/info) and also by reviewing information, literature and evaluation reports published by others.

Treatment Use Categories and Exposure Conditions



The American Wood Protection Association (AWPA) identifies 12 Use Category designations (UC) for wood treatment chemicals that are based on protection of the wood material; the Use Categories are based on service conditions and environments and agents of deterioration. At the same time, the building codes require specific corrosion resistance for connectors and fasteners that are in contact with chemically treated wood, and the corrosion resistance is independent of the service environments and treatments that are the basis of the AWPA Use Categories. From the building code perspective, fastener corrosion resistance is provided by hot-dip galvanization applied following ASTM A153, Class D or a corrosion resistant base metal, such as stainless steel, silicon bronze or copper regardless of exposure. Connectors in contact with preservative-treated wood require a minimum of ASTM A653, Type G185 zinc-coated galvanized steel, or equivalent.

Some exceptions are provided in the International Code Council's (ICC) International Residential Code (IRC) for mechanical galvanization applied to screws. The International Building Code (IBC) has exceptions for plain carbon steel fasteners, nuts and washers in SBX/DOT and zinc borate preservative-treated wood in interior, dry environments.

The International Code Council – Evaluation Service (ICC-ES) implemented AC257 as a method to evaluate alternate corrosion resistance mechanisms for fasteners used in wood construction where hot-dip galvanization (ASTM A153, Class D) is used as the benchmark performance. Under AC257, fastener corrosion resistance is qualified for one or more of four exposure conditions with no salt exposure: (1) treated wood in dry-service; (2) clean wood in a salt air dry-service environment; (3) treated wood in a wet-service condition; with no salt exposure; and (4) general use with no limitations.

COATINGS AVAILABLE

Not all products are available in all finishes.
Contact Simpson Strong-Tie for product availability, ordering information and lead times.

Finish/Material	Description	Level of Corrosion Resistance
Gray Paint	Water-based paint intended to protect the product while it is warehoused and in transit to the jobsite.	Low
Powder Coating	Baked on paint finish that is more durable than our standard paint and produces a better looking finished product.	Low
Standard G90 Zinc Coating	Zinc galvanized coating containing 0.90 oz. of zinc per square foot of surface area (<i>total both sides</i>).	Low
Electrocoating (E-Coat™)	Electrocoating utilizes electrical current to deposit the coating material on the fastener. After application, the coating is cured in an oven. Electrocoating provides a minimum amount of corrosion protection and is recommended for dry, non-corrosive applications only.	Low
	Galvanized (G185) 1.85 oz. of zinc per square foot of surface area (<i>hot-dip galvanized per ASTM A653 total both sides</i>). These products require hot-dip galvanized fasteners (<i>fasteners which meet the specifications of ASTM A153</i>).	Medium
	Products are hot-dip galvanized after fabrication (14 ga. and thicker). The coating weight increases with material thickness. The minimum <i>average</i> coating weight is 2.0 oz./ft ² (<i>per ASTM A123 total both sides</i>). These products require hot-dip galvanized fasteners (<i>fasteners which meet the specifications of ASTM A153</i>). Anchor bolts are hot-dip galvanized per ASTM F2329.	Medium
Type 410 Stainless Steel with Protective Top Coat	Carbon martensitic grade of stainless steel which is inherently magnetic, with an added protective top coat. This material can be used in mild atmospheres and many mild chemical environments.	Medium
Mechanically-Galvanized Coating, Class 55	Simpson Strong-Tie Strong-Drive® SD Connector screw is manufactured with a mechanically-applied zinc coating in accordance with ASTM B695, Class 55 with a supplemental overcoat. These fasteners are compatible with painted and zinc-coated (G90 and ZMAX) connectors.	Medium
Double-Barrier Coating	Simpson Strong-Tie Strong-Drive SDS Heavy-Duty Connector screw is manufactured with two different finishes that together provide a level of corrosion protection that equals that provided by the previous HDG coating.	Medium
	Connectors are manufactured from Type 316L stainless steel, and provide greater durability against corrosion. Stainless-steel nails are required with stainless-steel products, and are available from Simpson Strong-Tie.	High/Severe

See Corrosion Information for more specific performance and application information on these finishes.

CORROSION INFORMATION

Simpson Strong-Tie General Recommendations

Simpson Strong-Tie has evaluated the AWPA Use Categories (AWPA U1-13) and the ICC-ES, AC257 Exposure Conditions and developed from that evaluation a set of Corrosion Resistance Recommendations. These recommendations address the coating systems and materials used by Simpson Strong-Tie for connector and fastener products.

Dry-service (or damp-service) environments lead to wood moisture contents less than or equal to 19%. The corrosion potential, even in chemically treated wood, is reduced in these conditions. These conditions are typical of AWPA UC1 and UC2 for wood treatment and AC257 Exposure Condition 1. See the Corrosion Resistance Classification Table for the Simpson Strong-Tie assessment of corrosion needs in these conditions. The AC257 Exposure Condition 2 reflects the presence of air-borne salt in a dry-service environment and corrosion hazard to exposed metal surfaces; it does not include effects of treatment chemicals.

Outdoor environments are generally more corrosive to steel either because the moisture exposure is elevated (*greater than 19%*) and/or the treatment chemical retention level is higher than for interior service. The AWPA classifies exterior above ground treatments as Use Categories UC3 (A and B) depending on moisture run-off; and for ground-contact levels of protection, it has Use Categories UC4 (A-C). ICC-ES considers the exterior exposure to be limited by the type of chemicals and retention level of the chemicals in the qualification testing and whether the exposure includes salt exposure. In general, The AC257 Exposure Condition 3 includes AWPA Use Categories UC1 (*interior dry*) to UC4A (*exterior ground contact, general use*).

Types 316/305/304 stainless steel, copper, silicon bronze and hot-dip galvanized (Class-C) are the most effective protection against corrosion risk, where Type 316 is the best choice for salt marine and chloride containing environments

regardless of treatment chemicals or wood species. If you choose to use hot-dip galvanized (Class-D), mechanically galvanized (C3, N2000, or Class 55), double-barrier or Quik Guard coated fasteners on outdoor projects (*e.g., a deck*), you should periodically inspect the fasteners or have a professional inspection performed, and regular maintenance is a good practice. See the Corrosion Resistance Classifications Table for the Simpson Strong-Tie assessment of the corrosion resistance associated with materials and coatings and an appropriate level of corrosion resistance for various environments.

Due to the many variables involved, Simpson Strong-Tie cannot provide estimates of service life of connectors and fasteners. We suggest that all users and specifiers obtain recommendations on corrosion from the treated wood supplier or for the type of wood used. As long as Simpson Strong-Tie recommendations are followed, Simpson Strong-Tie stands behind its product performance and our standard warranty applies (page 19).

Simpson Strong-Tie does not recommend painting stainless steel fasteners or hardware. The reason behind this recommendation is that sometimes painting can facilitate corrosion. Stainless steel is "stainless" because it forms a protective chromium oxide film on the surface by passive oxidation with air. The paint film on the stainless steel surface may be imperfect or it can be injured during service, and in either case the metal may be exposed. Microscopic-sized film imperfections and scratches facilitate collection of dirt and water that can be stagnant and degrade or block the passive formation of the protective chromium oxide film. When this happens, crevice corrosion can initiate. Crevice corrosion eventually becomes visible as a brown stain or as red rust. This is the reason that painting usually does not improve corrosion resistance of stainless steel.

Guidelines for Selecting Corrosion-Resistant Connectors and Fasteners

Evaluate the Application

Consider the importance of the connection.

Evaluate the Exposure

Consider these moisture and treatment chemical exposure conditions:

- Dry service: Generally INTERIOR applications and includes wall and ceiling cavities, raised floor applications in enclosed buildings that have been designed to prevent condensation and exposure to other sources of moisture. Prolonged exposure during construction should also be considered, as this may constitute a Wet Service or Elevated Service Condition.
- Wet Service: Generally EXTERIOR construction in conditions other than Elevated Service. These include Exterior Protected and Exposed and General Use Ground Contact as described by the AWPA UC4A.
- Elevated Service: Includes fumes, fertilizers, soil, some preservative-treated wood (AWPA UC4B and UC4C), industrial zones, acid rain and other corrosive elements.
- Uncertain: Unknown exposure, materials, or treatment chemicals.
- Ocean/Water Front: Marine environments that include airborne chlorides and some splash. Environments with de-icing salts are included.
- Treatment Chemicals: See AWPA Use Category Designations. The preservative-treated wood supplier should provide all of the pertinent information about the wood being used. The information should include Use Category Designation, wood species group, wood treatment chemical, and chemical retention. See appropriate evaluation reports for corrosion effects of treatment chemicals and fastener corrosion resistance recommendations.

Use the Simpson Strong-Tie® Corrosion Classification Table

If the treatment chemical information is incomplete, Simpson Strong-Tie recommends the use of a 300 series stainless steel product. Also if the treatment chemical is not shown in the Corrosion Classification Table, then Simpson Strong-Tie has not evaluated it and cannot make any recommendations other than the use of coatings and materials in the Severe category. Manufacturers may independently provide test results of other product information; Simpson Strong-Tie expresses no opinion regarding such information.

CORROSION INFORMATION

CORROSION RESISTANCE RECOMMENDATIONS			
Low	Medium	High	Severe
FASTENERS			
Phosphate (gray, black), Clear (bright) zinc (ASTM F1941), Heavy electro-galvanized (ASTM A641-Class 1), Yellow zinc (ASTM F1941), Electrocoat (E-coat), Type 410 stainless steel	Mechanically galvanized (AS 3566.2-C3, N2000, ASTM B695-Class 55), Quik Guard® coating, Hot-dip galvanized (ASTM A153-Class D), Double-barrier coating, Type 410 stainless steel with protective top coat	Type 304 stainless steel, Type 305 stainless steel	Type 316 stainless steel, Hot-dip galvanized (ASTM A153-Class C), Silicon bronze, Copper
CONNECTORS			
Simpson Strong-Tie® gray paint Powder coating Standard G90 zinc coating	ZMAX® (G185) Hot-dip galvanized (ASTM A123 - Class D)	Type 316L stainless steel	Type 316L stainless steel

CORROSION RESISTANCE CLASSIFICATIONS							
Environment	Material To Be Fastened						
	Untreated Wood or Other Material	Preservative-Treated Wood					FRT Wood
		SBX-DOT Zinc Borate	Chemical Retention ≤ AWPA, UC4A	Chemical Retention > AWPA, UC4A	ACZA	Other or Uncertain	
Dry Service	Low	Low	Low	High	High	High	Med
Wet Service	Med	N/A	Med	High	High	High	High
Elevated Service	High	N/A	Severe	Severe	High	Severe	N/A
Uncertain	High	High	High	Severe	High	Severe	High
Ocean/Water Front	Severe	N/A	Severe	Severe	Severe	Severe	N/A

- These are general guidelines that may not consider all application criteria. Refer to product specific information for additional guidance.
- Type 316/305/304 stainless steel products are recommended where preservative-treated wood used in ground contact has a chemical retention level greater than those for AWPA UC4A; CA-C, 0.15 pcf; CA-B, 0.21 pcf; micronized CA-C, 0.14 pcf; micronized CA-B, 0.15 pcf; ACQ-Type D (or C), 0.40 pcf.
- Testing by Simpson Strong-Tie following ICC-ES AC257 showed that mechanical galvanization (ASTM B695, Class 55), Quik Guard coating, and Double Barrier coating will provide corrosion resistance equivalent to hot-dip galvanization (ASTM A153, Class D) in contact with chemically treated wood in dry service and wet service exposures (AWPA UC1-UC4A, ICC-ES AC257 Exposure Conditions 1 and 3) and will perform adequately subject to regular maintenance and periodic inspection.
- Mechanical galvanizations C3 and N2000 should not be used in conditions that would be more corrosive than AWPA UC3A (exterior, above ground, rapid water run off).
- If uncertain about Use Category, treatment chemical, or environment, use Types 316/305/304 stainless steel, silicon bronze or copper.
- Some treated wood may have excess surface chemicals making it potentially more corrosive than lower retentions. If this condition is suspected, use Type 316/305/304 stainless steel, silicon bronze, or copper fasteners.
- Type 316 stainless steel, silicon bronze, and copper fasteners are the best recommendation for ocean salt-air and other chloride-containing environments. Hot-dip galvanized fasteners with at least ASTM A153, Class C protection can also be an alternate for some applications in environments with ocean air and/or elevated wood moisture content.

Interior Dry



Exterior



Severe



C-C-2015 © 2015 SIMPSON STRONG-TIE COMPANY INC. PRINTED 12/14 (This page has been updated since printing)

IMPORTANT INFORMATION & GENERAL NOTES

WARNING

Simpson Strong-Tie Company Inc. structural connectors, anchors, and other products are designed and tested to provide specified design loads. To obtain optimal performance from Simpson Strong-Tie Company Inc. products and achieve maximum allowable design load, the products must be properly installed and used in accordance with the installation instructions and design limits provided by Simpson Strong-Tie Company Inc. To ensure proper installation and use, Designers and installers must carefully read the following General Notes, General Instructions for the Installer and General Instructions for the Designer, as well as consult the applicable catalog pages for specific product installation instructions and notes.

Proper product installation requires careful attention to all notes and instructions, including these basic rules:

1. Be familiar with the application and correct use of the connector.
2. Follow all installation instructions provided in the applicable catalog, website, *Installer's Pocket Guide* or any other Simpson Strong-Tie publications.
3. Install all required fasteners per installation instructions provided by Simpson Strong-Tie Company Inc.: a) use proper fastener type; b) use proper fastener quantity; c) fill all fastener holes; d) do not overdrive or underdrive nails, including when using gun nailers; and e) ensure screws are completely driven.
4. Only bend products that are specifically designed to be bent. For those products that required bending, do not bend more than once.
5. Cut joists to the correct length, do not "short-cut". The gap between the end of the joist and the header material should be no greater than 1/8" unless otherwise noted.

In addition to following the basic rules provided above as well as all notes, warnings and instructions provided in the catalog, installers, designers, engineers and consumers should consult the Simpson Strong-Tie Company Inc. website at www.strongtie.com to obtain additional design and installation information, including:

- Instructional builder/contractor training kits containing an instructional video, an instructor guide and a student guide in both English and Spanish;

- *Installer's Pocket Guide* (form S-INSTALL) which is designed specifically for installers and uses detailed graphics and minimal text in both English and Spanish to explain visually how to install many key products;
- Information on workshops Simpson Strong-Tie conducts at various training centers throughout the country;
- Product specific installation videos;
- Specialty catalogs;
- Code reports – Simpson Strong-Tie® Code Report Finder software;
- Technical fliers and bulletins;
- Master format specifications;
- Material safety data sheets;
- Corrosion information;
- Connector selection guides for engineered wood products (*by manufacturer*);
- Simpson Strong-Tie Connector Selector™ software;
- Simpson Strong-Tie Autocad menu;
- Simpson Strong-Tie Strong-Wall® Selector software;
- Simpson Strong-Tie Anchor Tiedown System Selector and anchor-related software; and
- Answers to frequently asked questions and technical topics.

Failure to follow fully all of the notes and instructions provided by Simpson Strong-Tie Company Inc. may result in improper installation of products. Improperly installed products may not perform to the specifications set forth in this catalog and may reduce a structure's ability to resist the movement, stress, and loading that occurs from gravity loads as well as impact events such as earthquakes and high velocity winds.

Simpson Strong-Tie Company Inc. does not guarantee the performance or safety of products that are modified, improperly installed or not used in accordance with the design and load limits set forth in this catalog.

GENERAL NOTES

These general notes are provided to ensure proper installation of Simpson Strong-Tie Company Inc. products and must be followed fully.

- Simpson Strong-Tie Company Inc. reserves the right to change specifications, designs, and models without notice or liability for such changes.
- Steel used for each Simpson Strong-Tie® product is individually selected based on the product's steel specifications, including strength, thickness, formability, finish, and weldability. Contact Simpson Strong-Tie for steel information on specific products.
- Unless otherwise noted, dimensions are in inches, loads are in pounds.
- Unless otherwise noted, welds, screws, bolts and nails may not be combined to achieve highest load value. 8d (0.131"x2 1/2"), 10d (0.148"x3"), and 16d (0.162"x3 1/2") specify common nails that meet the requirements of ASTM F1667. When a shorter nail is specified, it will be noted (for example 8dx1 1/2). Refer to Simpson Strong-Tie Nailing Guide, NDS (*National Design Specification*) and ASTM F1667 (*American Society of Testing and Materials*) for more nail info.
- Do Not Overload. Do not exceed catalog allowable loads, which would jeopardize the connection.
- Unless otherwise noted, allowable loads are for Douglas Fir-Larch under continuously dry conditions. Allowable loads for other species or conditions must be adjusted according to the code. The section from the AC13 criteria indicating the range of specific gravity reads as follows: **3.2.3** The species of lumber used shall have a specific gravity not greater than 0.55 as determined in accordance with the NDS. This chart shows specific gravity and perpendicular to grain compression capacities for the different wood species:

Species	Fc _⊥	Specific Gravity
Douglas Fir-Larch (DF)	625 psi	0.50
Southern Pine (SP)	565 psi	0.55
Spruce-Pine-Fir (SPF)	425 psi	0.42
Hem Fir (HF)	405 psi	0.43
Glulam	650 psi	0.50
LVL (DF/SP)	750 psi	0.50
LSL (E=1.3x10 ⁶)	680 psi	0.50
LSL (E≥1.5x10 ⁶)	880 psi	0.50
Parallam® PSL	750 psi	0.50
- Simpson Strong-Tie Company Inc. will manufacture non-catalog products provided prior approval is obtained and an engineering drawing is included with the order. Steel specified on the drawings as 1/8", 3/16", and 1/4" will be 11 gauge (0.120"), 7 ga (0.179"), and 3 gauge (0.239"), respectively. The minimum yield and tensile strengths are 33 ksi and 52 ksi, respectively.
- All references to bolts or machine bolts (MBs) are for structural quality through bolts (*not lag screws or carriage bolts*) equal to or better than ASTM Standard A307, Grade A.
- Unless otherwise noted, bending steel in the field may cause fractures at the bend line. Fractured steel will not carry load and must be replaced.
- A fastener that splits the wood will not take the design load. Evaluate splits to determine if the connection will perform as required. Dry wood may split more easily and should be evaluated as required. If wood tends to split, consider pre-boring holes with diameters not exceeding .75 of the nail diameter (2012 NDS 11.1.5.3). Use a 5/32" bit for Strong-Drive® SDS Heavy-Duty Connector screws and a 3/32" bit for Strong-Drive SD9/SD10 Connector screws.
- Wood shrinks and expands as it loses and gains moisture, particularly perpendicular to its grain. Take wood shrinkage into account when designing and installing connections. Simpson Strong-Tie manufactures products to fit common dry lumber dimensions. If you need a connector with dimensions other than those listed in this catalog, Simpson Strong-Tie may be able to vary connector dimensions; contact Simpson Strong-Tie. The effects of wood shrinkage are increased in multiple lumber connections, such as floor-to-floor installations. This may result in the vertical rod nuts becoming loose, requiring post-installation tightening. (*Contact Simpson Strong-Tie for information on Takeup Devices.*)
- Top flange hangers may cause unevenness. Possible remedies should be evaluated by a professional and include using a face mount hanger, and routing the beam or cutting the subfloor to accommodate the top flange thickness.
- Built-up lumber (*multiple members*) must be fastened together to act as one unit to resist the applied load (*excluding the connector fasteners*). This must be determined by the Designer/Engineer of Record.

IMPORTANT INFORMATION & GENERAL NOTES

GENERAL NOTES (cont.)

- n. Some model configurations may differ from those shown in this catalog. Contact Simpson Strong-Tie for details.
- o. Hanger Options (*Simpson Strong-Tie Hanger Options Matrix and Hanger Option General Notes pages 233-235*) – some combinations of hanger options are not available. In some cases, combinations of these options may not be installable. Horizontal loads induced by sloped joists must be resisted by other members in the structural system. A qualified Designer must always evaluate each connection, including carried and carrying member limitations, before specifying the product. Fill all fastener holes with fastener types specified in the tables, unless otherwise noted. Hanger configurations, height, and fastener schedules may vary from the tables depending on joist size, skew and slope. See the allowable table load for the non-modified hanger, and adjust as indicated. Gauge may vary from that specified depending on the manufacturing process used.
- p. Simpson Strong-Tie will calculate the net height for a sloped seat. The customer must provide the H1 joist height before slope.
- q. Truss plates shown are the responsibility of the Truss Designer.
- r. Do not weld products listed in this catalog unless this publication specifically identifies a product as acceptable for welding, or unless specific approval for welding is provided in writing by Simpson Strong-Tie. Some steels have poor weldability and a tendency to crack when welded. Cracked steel will not carry load and must be replaced. See Simpson Strong-Tie Hanger Options Matrix and Hanger Option General Notes on pages 233-235 for hangers that may be welded.
- s. Unless noted otherwise, all references to standard cut washers refer to Type A plain washers (W) conforming to the dimensions shown in ASME B18.22.1 for the appropriate rod size in accordance with 2012 NDS Appendix L. Some products require SAE narrow washers (N) to fit in a tight space and are noted accordingly.

GENERAL INSTRUCTIONS FOR THE INSTALLER

These general instructions for the installer are provided to ensure proper selection and installation of Simpson Strong-Tie Company Inc. products and must be followed carefully. These general instructions are in addition to the specific installation instructions and notes provided for each particular product, all of which should be consulted prior to and during installation of Simpson Strong-Tie Company Inc. products.

- a. All specified fasteners must be installed according to the instructions in this catalog. Incorrect fastener quantity, size, placement, type, material, or finish may cause the connection to fail. Prior to using a particular fastener, please consult the Fastener Guide in this catalog.
 - 16d fasteners are common nails (0.162" dia. x 3½" long) and cannot be replaced with 16d sinkers (0.148" dia. x 3¼" long) for full load value unless otherwise specified.
 - Unless otherwise noted screws may not be used to replace nails in connectors unless approved and recommended by the Designer/Engineer of Record. Unless stated otherwise, Simpson Strong-Tie cannot and does not make any representations regarding the suitability of use or load-carrying capacities of connectors with screws replacing nails.
 - When using stainless-steel connectors, use stainless-steel fasteners. When using ZMAX®/HDG galvanized connectors, use fasteners that meet the zinc coating specifications of ASTM A153 or other fasteners allowed in this catalog.
- b. Fill all fastener holes as specified in the installation instructions for that product. Refer to page 23 for the requirements of the various shapes of fastener hole.
- c. Do not overdrive nails. Overdriven nails reduce shear capacity.
- d. Use the materials specified in the installation instructions. Substitution of or failure to use specified materials may cause the connection to fail.
- e. Do not add fastener holes or otherwise modify Simpson Strong-Tie Company Inc. products. The performance of modified products may be substantially weakened. Simpson Strong-Tie will not warrant or guarantee the performance of such modified products.
- f. Install products in the position specified in the catalog.
- g. Do not alter installation procedures from those set forth in this catalog.
- h. The proper use of certain products requires that the product be bent. For those products, installers must not bend the product more than one time (*one full cycle*).
- i. Bolt holes shall be at least a minimum of ½³²" and no more than a maximum of ¼¹⁶" larger than the bolt diameter (*per the 2012 NDS, section 11.1.3.2 and AISI S100-07, Table E3a if applicable*).
- j. Install all specified fasteners before loading the connection.
- k. Some hardened fasteners may have premature failure if exposed to moisture. These fasteners are recommended to be used in dry interior applications.
- l. Use proper safety equipment.
- m. Welding galvanized steel may produce harmful fumes; follow proper welding procedures and safety precautions. Welding should be in accordance with A.W.S. (*American Welding Society*) standards. Unless otherwise noted Simpson Strong-Tie® connectors cannot be welded.
- n. Pneumatic or powder-actuated fasteners may deflect and injure the operator or others. Pneumatic nail tools may be used to install connectors, provided the correct quantity and type of nails (*length and diameter*) are properly installed in the nail holes. Tools with nail hole-locating mechanisms should be used. Follow the manufacturer's instructions and use the appropriate safety equipment. Overdriving nails may reduce allowable loads. Contact Simpson Strong-Tie. Powder-actuated fasteners should not be used to install connectors.
- o. Joist shall bear completely on the connector seat, and the gap between the joist end and the header shall not exceed ⅛" per ICC-ES AC261, ASTM D1761 and ASTM D7147 test standards (*unless specifically noted otherwise*).
- p. For holdowns, anchor bolt nuts should be finger-tight plus ⅓ to ½ turn with a hand wrench, with consideration given to possible future wood shrinkage. Care should be taken to not over-torque the nut. Impact wrenches should not be used as they may preload the holddown.
- q. Holdowns and Tension Ties may be raised off the sill as dictated by field conditions to accommodate an anchor mislocated no more than 1½". The holddown shall be raised off the sill at least 3" for every ¼" that the anchor is offset from the model's centerline. Anchor bolt slope shall be no greater than 1:12 (*or 5 degrees*). Contact the Designer if the holddown anchor is offset more than 1½" or raised more than 18". Raised holddown height is measured from the top of concrete to the top of the holddown bearing plate.
- r. Fasteners are permitted to be installed through metal truss plates when approved by the Truss Designer in accordance with ANSI/TPI 1-2007, Section 7.5.3.4 and 8.9.2. Installation of Simpson Strong-Tie® Strong-Drive® SDS Heavy-Duty Connector screws through metal connector plates requires the plates to be pre-drilled using a maximum of a 5⁄32" bit. Do not drive nails through the truss plate on the opposite side of single-ply trusses which could force the plate off the truss.
- s. For cold-formed steel applications, all screws shall be installed in accordance with the screw manufacturer's recommendations. All screws shall penetrate and protrude through the joined materials a minimum of 3 full exposed threads per AISI Standard for Cold Formed Steel Framing – General Provisions, section D1.3, if applicable.
- t. Nuts shall be installed such that the end of the threaded rod or bolt is at least flush with the top of the nut.
- u. When installing hurricane ties on the inside of the wall special considerations must be taken to prevent condensation on the inside of the completed structure in cold climates.
- v. Unless otherwise noted, connectors shown in this catalog have been designed to be installed at the time the framing members are installed. Contact Simpson Strong-Tie for retrofit suitability of specific connectors including those manufactured in accordance with the hanger options section of this catalog.

IMPORTANT INFORMATION & GENERAL NOTES

GENERAL INSTRUCTIONS FOR THE DESIGNER

These general instructions for the Designer are provided to ensure proper selection and installation of Simpson Strong-Tie Company Inc. products and must be followed carefully. These general instructions are in addition to the specific design and installation instructions and notes provided for each particular product, all of which should be consulted prior to and during the design process.

- a. The term “Designer” used throughout this catalog is intended to mean a licensed/certified building design professional, a licensed professional engineer, or a licensed architect.
- b. All connected members and related elements shall be designed by the Designer.
- c. All installations should be designed only in accordance with the allowable load values set forth in this catalog.
- d. Unless otherwise noted, connector allowable loads published in this catalog are limited to the lowest of: average recorded test load at $\frac{1}{8}$ " deflection, lowest ultimate recorded test load of 3 tests specimens divided by 3 (or the average of 6 specimens divided by 3), or the calculated value based on steel, wood bearing, and/or fastener capacity.
- e. When a connector is loaded simultaneously in more than one direction, the allowable load must be evaluated as shown here. For all connectors use the following equation:

$$\frac{\text{Design Uplift/Allowable Uplift} + \text{Design Lateral Parallel to Plate}}{\text{Allowable Lateral Parallel to Plate} + \text{Design Lateral Perpendicular to Plate}} / \frac{\text{Design Lateral Perpendicular to Plate}}{\text{Allowable Lateral Perpendicular to Plate}} < 1.0.$$

The three terms in the unity equation are due to the possible directions that exist to generate force on a connector. The number of terms that must be considered for simultaneous loading is at the sole discretion of the Designer and is dependent on their method of calculating wind forces and the utilization of the connector within the structural system.

As an alternate, certain roof-to-wall connectors (*embedded truss anchors, pages 180 and 181, seismic and hurricane ties, pages 178-179, and twist straps, page 168*) can be evaluated using the following: The design load in each direction shall not exceed the published allowable load in that direction multiplied by 0.75.
- f. Loads are based on the 2012 National Design Specifications (NDS) and AISI S100-07 if applicable, unless otherwise specified. Other code agencies may use different allowable loads.
- g. Duration of load adjustments as specified by the code are as follows:
 - “FLOOR” and “DOWN” (100)—no increase for duration of load.
 - “SNOW” (115)—115% of design load for 2 month duration of load.
 - “ROOF LOAD” (125)—125% of design load for 7 day duration of load.
 - “EARTHQUAKE/WIND” (160)—160% of design load for earthquake/wind loading.
- h. Unless otherwise noted, wood shear is not considered in the loads given; reduce allowable loads when wood shear is limiting.
- i. Simpson Strong-Tie strongly recommends the following addition to construction drawings and specifications: “Simpson Strong-Tie® connectors are specifically required to meet the structural calculations of plan. Before substituting another brand, confirm load capacity based on reliable published testing data or calculations. The Engineer/Designer of Record should evaluate and give written approval for substitution prior to installation.”
- j. Verify that the dimensions of the supporting member are sufficient to receive the specified fasteners, and develop the top flange bearing length.
- k. Some catalog illustrations show connections that could cause cross-grain tension or bending of the wood during loading if not sufficiently reinforced. In this case, mechanical reinforcement should be considered.
- l. For holdowns, anchor bolt nuts should be finger-tight plus $\frac{1}{8}$ to $\frac{1}{2}$ turn with a hand wrench, with consideration given to possible future wood shrinkage. Care should be taken to not over-torque the nut. Impact wrenches should not be used as they may preload the holddown.
- m. Simpson Strong-Tie will provide upon request code testing data on all products that have been code tested.
- n. The allowable loads published in this catalog are for use when utilizing the traditional Allowable Stress Design methodology. A method for using Load and Resistance Factor Design (LRFD) for wood has been published in ASTM D5457. A method for using LRFD for cold-formed steel has also been published in the AISI S100-07. When designing with LRFD, reference lateral resistances must be used. Contact Simpson Strong-Tie for reference lateral resistances of products listed in this catalog. For more information, refer to the 2012 NDS Appendix N, which contains a conversion procedure that can be used to derive LRFD capacities.
- o. For joist hangers, Simpson Strong-Tie recommends the hanger height shall be at least 60% of joist height for stability.
- p. For cold-formed steel applications, as a minimum all screws must comply with Society of Automotive Engineers (SAE) Standard J78, Steel Self-Drilling/Tapping Screws, and must have a Type II coating in accordance with ASTM B 633, Electrodeposited Coatings of Zinc on Iron and Steel. Screw strength shall be calculated in accordance with AISI S100-07 Section E4, if applicable, or shall be based on the manufacturer’s design capacity determined from testing.
- q. Local and/or regional building codes may require meeting special conditions. Building codes often require special inspection of anchors installed in concrete and masonry. For compliance with these requirements, it is necessary to contact the local and/or regional building authority. Except where mandated by code, Simpson Strong-Tie products do not require special inspection.
- r. Holddown and Tension Tie allowable loads are based on installations with an anchor rod length of 6" from the concrete to top of holddown seat, yet these products may be raised to any height with consideration of the increased deflection due to additional bolt elongation. For cases where the anchor bolt is offset, Simpson Strong-Tie offers recommendations, subject to the approval of the Designer, which permit holdowns to be raised up to 18" maximum with a corresponding horizontal anchor bolt offset of $1\frac{1}{2}$ ". See “General Instructions for the Installer” (page 17 note q).
- s. Throughout the catalog there are installation drawings showing the load transfer from one element in the structure to another. Additional connections may be required to safely transfer the loads through the structure. It is the Designer’s responsibility to specify and detail all necessary connections to ensure that a continuous load path is provided as required by the building code.
- t. Top flange hanger allowable loads are typically based on testing with solid headers. Load reductions may apply when using headers comprised of multiple plies of dimensioned lumber or SCL. See technical bulletin T-MPLYHEADER for more information.

IMPORTANT INFORMATION & GENERAL NOTES

LIMITED WARRANTY

Simpson Strong-Tie Company Inc. warrants catalog products to be free from defects in material or manufacturing. Simpson Strong-Tie Company Inc. products are further warranted for adequacy of design when used in accordance with design limits in this catalog and when properly specified, installed, and maintained. This warranty does not apply to uses not in compliance with specific applications and installations set forth in this catalog, or to non-catalog or modified products, or to deterioration due to environmental conditions.

Simpson Strong-Tie® connectors are designed to enable structures to resist the movement, stress, and loading that results from impact events such as earthquakes and high velocity winds. Other Simpson Strong-Tie products are designed to the load capacities and uses listed in this catalog. Properly-installed Simpson Strong-Tie products will perform in accordance with the specifications set forth in the applicable Simpson Strong-Tie catalog. Additional performance limitations for specific products may be listed on the applicable catalog pages.

Due to the particular characteristics of potential impact events, the specific design and location of the structure, the building materials used, the quality

of construction, and the condition of the soils involved, damage may nonetheless result to a structure and its contents even if the loads resulting from the impact event do not exceed Simpson Strong-Tie catalog specifications and Simpson Strong-Tie connectors are properly installed in accordance with applicable building codes.

All warranty obligations of Simpson Strong-Tie Company Inc. shall be limited, at the discretion of Simpson Strong-Tie Company Inc., to repair or replacement of the defective part. These remedies shall constitute Simpson Strong-Tie Company Inc.'s sole obligation and sole remedy of purchaser under this warranty. In no event will Simpson Strong-Tie Company Inc. be responsible for incidental, consequential, or special loss or damage, however caused.

This warranty is expressly in lieu of all other warranties, expressed or implied, including warranties of merchantability or fitness for a particular purpose, all such other warranties being hereby expressly excluded. This warranty may change periodically – consult our website www.strongtie.com for current information.

TERMS & CONDITIONS OF SALE

PRODUCT USE

Products in this catalog are designed and manufactured for the specific purposes shown, and should not be used with other connectors not approved by a qualified Designer. Modifications to products or changes in installations should only be made by a qualified Designer. The performance of such modified products or altered installations is the sole responsibility of the Designer.

INDEMNITY

Customers or Designers modifying products or installations, or designing non-catalog products for fabrication by Simpson Strong-Tie Company Inc. shall, regardless of specific instructions to the user, indemnify, defend, and hold harmless Simpson Strong-Tie Company Inc. for any and all claimed loss or damage occasioned in whole or in part by non-catalog or modified products.

NON-CATALOG AND MODIFIED PRODUCTS

Consult Simpson Strong-Tie Company Inc. for applications for which there is no catalog product, or for connectors for use in hostile environments, with excessive wood shrinkage, or with abnormal loading or erection requirements.

Non-catalog products must be designed by the customer and will be fabricated by Simpson Strong-Tie in accordance with customer specifications.

Simpson Strong-Tie cannot and does not make any representations regarding the suitability of use or load-carrying capacities of non-catalog products. Simpson Strong-Tie provides no warranty, express or implied, on non-catalog products. F.O.B. Shipping Point unless otherwise specified.

CONVERSION CHARTS

Metric Conversion

Imperial	Metric
1 in	25.40 mm
1 ft	0.3048 m
1 lb	4.448N
1 Kip	4.448 kN
1 psi	6895 Pa

Bolt Diameter

in.	mm
3/8	9.5
1/2	12.7
5/8	15.9
3/4	19.1
7/8	22.2
1	25.4

If Common Rafter Roof Pitch is...

Rise/Run	Slope
1/12	5°
2/12	10°
3/12	14°
4/12	18°
5/12	23°
6/12	27°
7/12	30°
8/12	34°
9/12	37°
10/12	40°
11/12	42°
12/12	45°

Then Hip/Valley Rafter Roof Pitch becomes...

Rise/Run	Slope
1/17	3°
2/17	7°
3/17	10°
4/17	13°
5/17	16°
6/17	19°
7/17	22°
8/17	25°
9/17	28°
10/17	30°
11/17	33°
12/17	35°

US Standard Steel Gauge Equivalents in Nominal Dimensions

Ga	Min. Thick. (mils)	Approximate Dimensions		Decimals (in.)		
		in.	mm	Uncoated Steel	Galvanized Steel (G90)	ZMAX (G185)
3	229	1/4	6.0	0.239	—	—
7	171	3/16	4.5	0.179	0.186	—
10	118	3/64	3.5	0.134	0.138	0.140
11	111	1/8	3.1	0.120	0.123	0.125
12	97	7/64	2.7	0.105	0.108	0.110
14	68	3/64	2.0	0.075	0.078	0.080
16	54	1/16	1.6	0.060	0.063	0.065
18	43	3/64	1.3	0.048	0.052	0.054
20	33	1/32	1.0	0.036	0.040	0.042
22	27	1/32	1.0	0.030	0.033	0.035

Steel thickness varies according to mill standards.

Use these Roof Pitch to Hip/Valley Rafter Roof Pitch conversion tables only for hip/valley rafters that are skewed 45° right or left. All other skews will cause the slope to change from that listed.

Click and Build

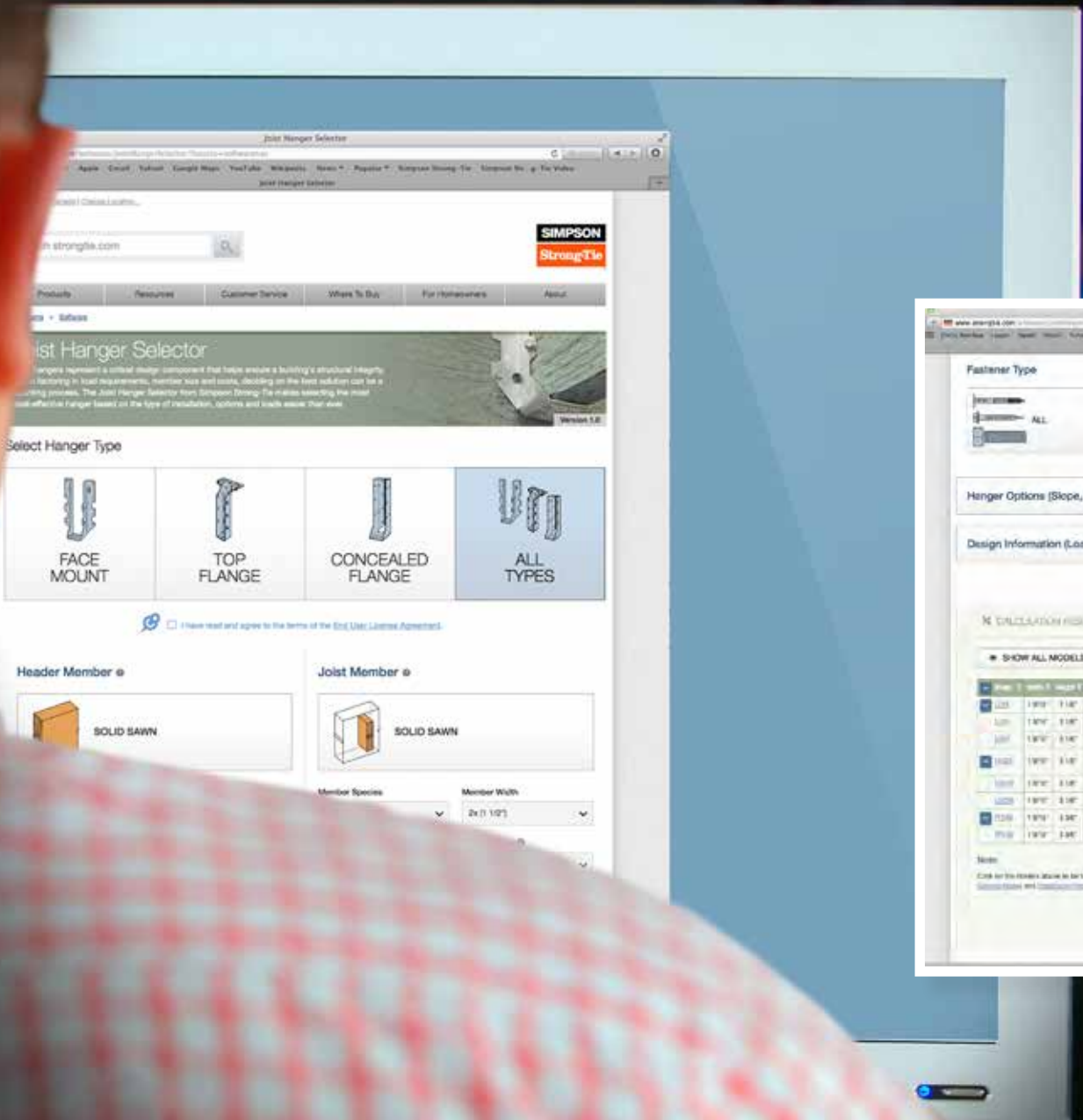

Fastener Type

Hanger Options (Slope, Skew, Etc...)

Design Information (Loads)

CALCULATION RESULTS

SHOW ALL MODELS

Model	Width	Depth	Length	Weight
L201	1 1/2"	1 1/2"	1 1/2"	1.12
L202	1 3/4"	1 1/2"	1 1/2"	1.12
L203	1 3/4"	1 3/4"	1 1/2"	1.12
L204	1 3/4"	1 1/2"	1 3/4"	1.12
L205	1 3/4"	1 3/4"	1 3/4"	1.12
L206	1 3/4"	1 3/4"	1 3/4"	1.12
L207	1 3/4"	1 3/4"	1 3/4"	1.12
L208	1 3/4"	1 3/4"	1 3/4"	1.12
L209	1 3/4"	1 3/4"	1 3/4"	1.12
L210	1 3/4"	1 3/4"	1 3/4"	1.12

Note:
Click for the details about the fastener for the product and
Specification and Installation instructions.

Simpson Strong-Tie Apps Are Designed to Help You Do Your Job Faster and Easier

At Simpson Strong-Tie, we believe the principles for introducing new software are no different from designing a new connector. We leverage the latest technology to help Specifiers and builders create safer, stronger structures in less time than ever before. Our unmatched variety of product selector and calculator apps help you find the best product, information and resources needed to do the job right the first time. **And they are all free!** Visit www.strongtie.com/software to learn more about our technology offerings.

Find the Right Joist Hanger – Fast

The web app enables customers to quickly and easily select the most appropriate and cost-effective hanger for their projects based on the type of installation, type and size of lumber and loads.



Match Your Anchor with the Right Connector

Our Connector-Anchor selector software helps discern the required embedment depth of our anchoring products when used with a Simpson Strong-Tie holdown or post base product.

Select the Right Holdown

The Holdown Selector is a quick and easy tool that selects the most cost-effective holdown connector based on the type of installation, demand load and wood species.



Get Simpson Strong-Tie Knowledge on Your Mobile Device

Need to find out how many Simpson Strong-Tie® adhesive cartridges you require for a job? Perhaps you're looking for some literature to learn more about a new product? Simpson Strong-Tie now delivers exciting mobile apps to your iPhone™, iPad™ or Android™ mobile device. Simply download and easily access information about our most popular products and even find the closest Simpson Strong-Tie dealer to purchase them.



CONNECT WITH US!

Now you can connect with Simpson Strong-Tie through several social media channels, including our Structural Engineering Blog.



FASTENER TYPES

Fastener Types and Sizes Specified for Simpson Strong-Tie® Connectors

Many Simpson Strong-Tie connectors have been designed and tested for use with specific types and sizes of fasteners. The specified quantity, type and size of fastener must be installed in the correct holes on the connector to achieve published loads. Other factors such as fastener material and finish are also important. Incorrect fastener selection or installation can compromise connector performance and could lead to failure.

Simpson Strong-Tie does not offer all of these fasteners. For more information about fasteners, see our *Fastening Systems* catalog or access our Fastener Finder software at www.strongtie.com/software.

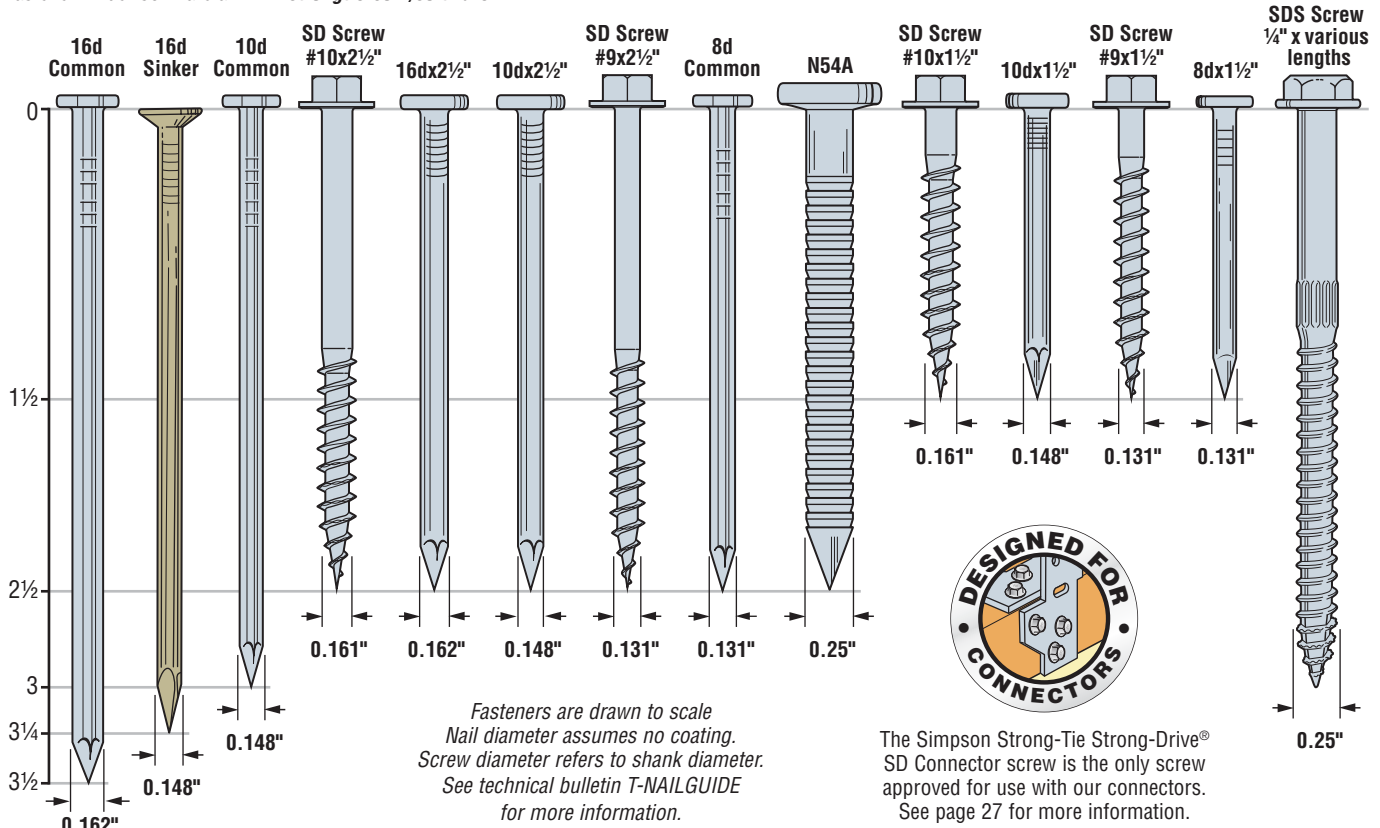

The Simpson Strong-Tie Strong-Drive® SD Connector screw is the only screw approved for use with our connectors. See page 27 for more information.

FASTENER DESIGN INFORMATION

In some cases, it is desirable to install Simpson Strong-Tie face mount joist hangers and straight straps with nails that are a different type or size than what is called out in the load table. In these cases, these reduction factors must be applied to the allowable loads listed for the connector.

Load Adjustment Factors for Optional Fasteners Used with Face Mount Hangers and Straight Straps

Catalog Nail	Replacement	Allowable Load Adjustment Factor	
		Face Mount Hangers	Straight Straps
16d common (0.162"x3 1/2")	10dx1 1/2 (0.148"x1 1/2")	0.64	0.84 ⁹
16d common (0.162"x3 1/2")	10d common (0.148"x3") 12d common (0.148"x3 1/4") 16d sinker (0.148"x3 1/4")	0.84	0.84
16d common (0.162"x3 1/2")	16dx2 1/2 (N16) (0.162"x2 1/2")	1.00	1.00
10d common (0.148"x3")	10dx2 1/2 (0.148"x2 1/2")	0.85	1.00
10d common (0.148"x3")	10dx1 1/2 (0.148"x1 1/2")	0.77	1.00 ¹⁰
16d sinker (0.148"x3 1/4")	10dx1 1/4 (0.148"x1 1/4")	0.64	1.00 ¹⁰
10d common (0.148"x3")	16d sinker (0.148"x3 1/4")	1.00	1.00
8d common (0.131"x2 1/2")	8dx1 1/2 (0.131"x1 1/2")	0.85	1.00
10d common (0.148"x3")	8d common (0.131"x2 1/2")	0.83	0.83
16d common (0.162"x3 1/2")	SD#10x1 1/2 (0.161x1 1/2")	1.00 ⁵	1.00
16dx2 1/2 (N16) (0.162x2 1/2)			
10d common (0.148"x3")	SD#9x1 1/2 (0.131x1 1/2")	1.00 ⁵	1.00
16d sinker (0.148"x3 1/4")			
10d x1 1/2 (0.148"x1 1/2)			
8d common (0.131"x2 1/2")			
8dx1 1/2 (0.131"x1 1/2")			

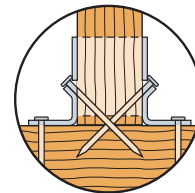

Double-shear nailing should use full length common nails

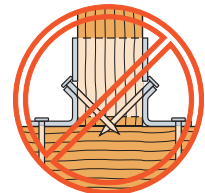

Shorter nails may not be used as double shear nails

- Allowable load adjustment factors shown in the table are based on calculated reduction factors and are applicable for all face mount hangers and straight straps throughout this catalog, except as noted in the footnotes below.
- Some products have been tested specifically with alternate fasteners and have allowable load adjustment factors or reduced capacities published on the specific product page which may differ from the values calculated using this table.
- This table does not apply to SUR/L hangers or to hangers modified per the Hanger Options described on pages 233-243, or steel thicker than 10 gauge.
- Unless noted otherwise, fasteners shorter than 3" in length may not be substituted for specified joist nails in double-shear hangers (i.e. LUS, MUS, HUS, HHUS, HGUS). For applications involving pneumatic nails, refer to technical bulletin T-PNEUMATIC.
- Strong-Drive® SD Connector screw substitutions in this table do not apply to sloped, skewed or double-shear hangers. For additional information and specific allowable loads, refer to www.strongtie.com/sd.
- Nails and Strong-Drive SD Connector screws may not be combined in a connection.
- Do not substitute 10dx1 1/2" nails for face nails on slope and skew combinations or skewed only LSU and LSSU.
- For straps installed over sheathing use a 2 1/2" long fastener minimum.
- Where noted, use 0.80 for 10 ga, 11 ga, and 12 ga products when using SPF lumber.
- Where noted, use 0.92 for 10 ga, 11 ga, and 12 ga products when using SPF lumber.

FASTENING IDENTIFICATION

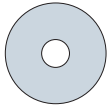

Round Holes
Purpose: to fasten a connector.
Fill Requirements: always fill, unless noted otherwise.

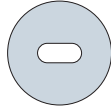

Obround Holes
Purpose: to make fastening a connector in a tight location easier.
Fill Requirements: always fill.

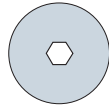

Hexagonal Holes
Purpose: to fasten a connector to concrete or masonry.
Fill Requirements: always fill when fastening a connector to concrete or masonry.

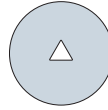

Triangular Holes
Purpose: to increase a connector's strength or to achieve Max strength.
Fill Requirements: always fill when the Designer specifies Max nailing.

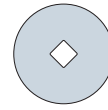

Diamond Holes
Purpose: to temporarily fasten a connector to make installing it easier.
Fill Requirements: none.

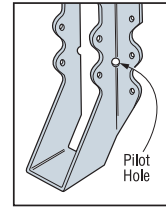

Pilot Holes
Tooling holes for manufacturing purposes. No fasteners required.

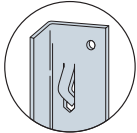

Speed Prongs
Used to temporarily position and secure the connector for easier and faster installation.

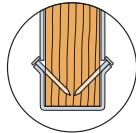

Positive Angle Nailing (PAN)
Provided when wood splitting may occur, and to speed installation.

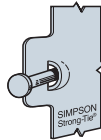

Dome Nailing
This feature guides the nail into the joist and header at a 45° angle. U.S. Patent 5,603,580

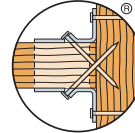

Double-Shear Nailing
The nail is installed into the joist and header, distributing the load through two points on each joist nail for greater strength.

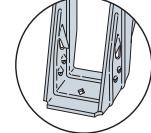

ITS/IUS Strong-Grip™
The Strong-Grip™ seat allows the I-joist to "snap" in securely without the need for joist nails.

STRONG-DRIVE® CONNECTOR NAILS

Simpson Strong-Tie nails and structural fasteners have been developed as the optimum fasteners for connector products. Special lengths afford economy of purchase and installation, and depth compatibility with framing members.

For pneumatic nail use, see Instructions to the Installer, page 17 and visit www.strongtie.com for technical bulletins.

Retail Packaging



1 lb. Retail Tub



5 lb. Retail Bucket

Simpson Strong-Tie hot-dip galvanized nails are packed in 1 lb. and 5 lb. plastic retail containers for easy handling.

Nails Sold by the Pound

Nail	Simpson Model No.	Dimensions	Wire Gauge	Finish
8dx1 1/2"	N8	0.131" x 1 1/2" (3.3mm x 38.1mm)	10 1/4	HDG
	SSN8			SS
8d Common	SS8D	0.131" x 2 1/2" (3.3mm x 63.5mm)	10 1/4	SS
10dx1 1/2"	N10	0.148" x 1 1/2" (3.8mm x 38.1mm)	9	HDG
	SSN10			SS
10d Common	10DHDG	0.148" x 3" (3.8mm x 76.2mm)	9	HDG
	SS10D			SS
16dx2 1/2"	N16	0.162" x 2 1/2" (4.1mm x 63.5mm)	8	Bright
16d Common	16DHDG	0.162" x 3 1/2" (4.1mm x 88.9mm)	8	HDG
	SS16D			SS
N54A	N54A	0.250" x 2 1/2" (6.4mm x 63.5mm)	3	Bright
	N54AHDG			HDG

1. HDG = hot-dip galvanized; SS = stainless steel; Bright = no finish.
2. For pneumatic fastener info, request additional technical information.
3. Use HDG nails with ZMAX® and HDG products.
4. 16d sinker with GV finish is not acceptable for ZMAX or HDG applications.
5. HDG nails sold by Simpson Strong-Tie meet the specifications of ASTM A153. Stainless-steel nails are type 316 stainless.

COLLATED STRONG-DRIVE® CONNECTOR NAILS

Simpson Strong-Tie® Strong-Drive® SCNR Ring-Shank Connector nails are designed to provide installers a pneumatically-driven alternative to hand-driven nails. The nail is approved for use in many popular Simpson Strong-Tie® products and serves as a replacement for 8d, 10d, and 16d hand-driven common nails in a variety of Simpson Strong-Tie connector applications. Available in 25-nail, paper-collated strips in both carbon steel and stainless steel.

MATERIAL: Heat-treated carbon steel, hot-dip galvanized, stainless steel

INSTALLATION: • Use all specified fasteners; see General Notes.

- Follow the manufacturer's instructions and use the appropriate safety equipment.
- Tools with nail hole-locating mechanisms should be used.
- Overdriving nails may reduce allowable loads.
- Compatible with a wide variety of popular pneumatic nailers. For more information, access our Fastener Finder software or download the Simpson Strong-Tie Fastening Systems catalog at www.strongtie.com.
- For applications involving pneumatic nails, refer to technical bulletin T-PNEUMATIC.

Model No.	Nominal Size	Diameter (in.)	Length (in.)
Hot-Dip Galvanized			
N8HDGPT500	8d	0.131	1 1/2
8DHDGPT500	8d	0.131	2 1/2
N10HDGPT500	10d	0.148	1 1/2
N10DHDGPT500	10d	0.148	2 1/2
N16HDGPT500	16d	0.162	2 1/2
Stainless Steel			
T9A150MCN	10d	0.148	1 1/2
T9A250MCN	10d	0.148	2 1/2



**Strong-Drive® 33°
SCNR Ring-Shank
Connector Nail**

FASTENERS

See our *Fastening Systems* catalog (C-F-14) for more information or access our online Fastener Finder at www.strongtie.com/fasteners.

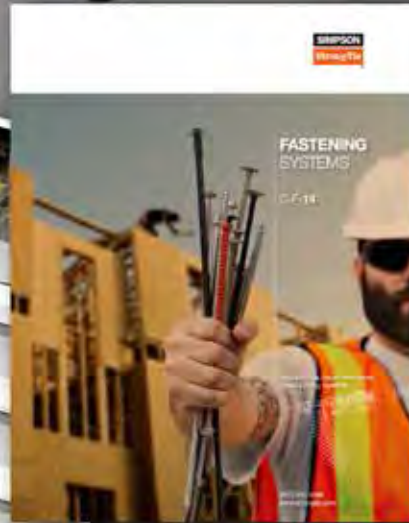

QUICK DRIVE® AUTO-FEED SCREW DRIVING SYSTEMS

The systems offer several easy-to-use attachments bringing speed and reliability to applications that require the fastening power of screws. Our attachments provide tough, reliable performance in specific fastening applications.

FASTENERS FOR QUIK DRIVE SYSTEMS

Featuring patented collation technology, these fasteners are designed to meet or exceed industry standards for strength and longevity while offering easy-to-load, tangle-free strips for efficient performance in auto-feed systems.



For more information, visit www.strongtie.com

STRONG-DRIVE® FASTENERS

Strong-Drive® WSNTL SUBFLOOR Screw

Fasteners for the Simpson Strong-Tie® Quik Drive auto-feed screw driving systems offer superior performance and reduced installation time in subfloor applications. The holding power of screws reduces the gaps that cause floor squeaks and the tool extension enables stand-up-and-drive installation.

CODES: ICC-ES ESR-1472; City of L.A. RR25661; Florida FL 13731

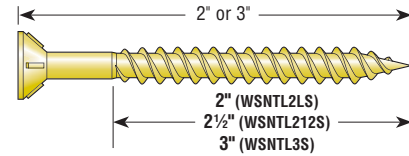

Allowable Shear (in Pounds per Foot) for Wood Structural Panel Diaphragms with Framing of Douglas Fir-Larch or Southern Pine for Wind or Seismic Loading

Panel Grade	Minimum Nominal Panel Thickness (in.)	Minimum Nominal Width of Framing Members at Adjoining Panel Edges and Boundaries (in.) ^{4,5}	BLOCKED DIAPHRAGMS				UNBLOCKED DIAPHRAGMS	
			Screw spacing (inches) at diaphragm boundaries (all cases), at continuous panel edges parallel to load (Cases 3 and 4), and at all edges (Cases 5 and 6) ⁶				Screws spaced 6 inches, maximum, at support edges ⁶	
			6	4	2 1/2 ⁷	2 ⁷	Case 1 (no unblocked edges or continuous joints parallel to load)	All other configurations (Cases 2,3,4,5 and 6)
			Screw Spacing (inches) at Other Panel Edges					
Structural 1/OSB	3/8	2	270	360	530	600	240	180
		3	300	400	600	675	265	200
	15/32	2	320	425	640	730	285	215
		3	360	480	720	820	320	240
Sheathing single floor, and other grades covered in DOC PS1 and PS2	3/8	2	240	320	480	545	215	160
		3	270	360	540	610	240	180
	7/16	2	255	340	505	575	230	170
		3	285	380	570	645	255	190
	15/32	2	290	385	575	655	255	190
		3	325	430	650	735	290	215
	19/32	2	320	421	640	730	285	215
		3	360	480	720	820	320	240

- Minimum fastener penetration of 1 1/4" into the framing member is required.
- For wind design, shear capacities may be increased 40% per section 2306.2.1 of the 2009 IBC and section 2306.2 of the 2012 IBC.
- For shear loads of normal or permanent load duration as defined by the AF&PA NDS, the values in the table above must be multiplied by 0.63 or 0.56, respectively.
- The minimum nominal width of framing members not located at boundaries or adjoining panel edges must be 2 inches.
- Framing at adjoining panel edges must be 3 inches nominal or wider, and screws must be staggered where both of the following conditions are met: (1) screws having penetration into framing of more than 1 1/2 inches and (2) screws are spaced 3 inches o.c. or less.
- Space screws maximum 12 inches o.c. along intermediate framing members (6 inches o.c. where supports are spaced 48 inches o.c.).
- Framing at adjoining panel edges must be 3-inch nominal or wider, and screws must be staggered where screws are spaced 2 inches or 2 1/2 inches on center.
- See ESR-1472, Table 1 for illustrations showing Cases 1 through 6.
- See ESR-1472 for allowable shear loads for high load diaphragms.
- WSNTL withdrawal and pull-thru values exceed those for a 10d common nail.
- See ESR-1472 for high load diaphragm design values.

Strong-Drive® TB WOOD-TO-STEEL Screw

Simpson Strong-Tie Quik Drive auto-feed systems with TB series screw strips are a fast and reliable way to fasten wood to steel members. Available in loose and collated options. They are self-drilling so no predrilling is required.

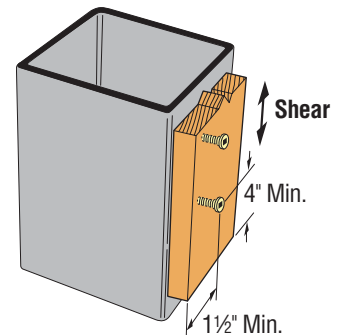
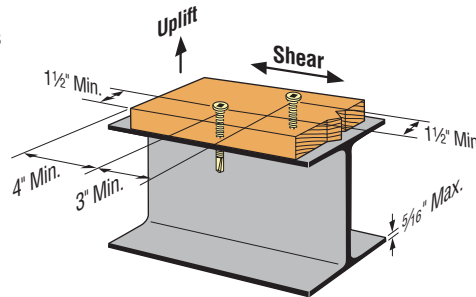
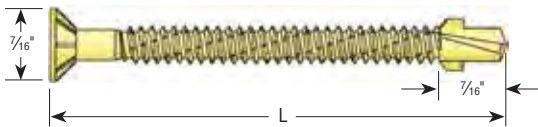

TB – Allowable Loads – DF and SP Lumber Attachment to Steel (Steel Members 16 ga - 5/16" Thick)

Model No.	Length in. (mm)	Nominal Wood Thickness	Steel Thickness mil (ga)	DF/SP Allowable Load			
				Uplift		Shear	
				C _D =1.0	C _D =1.6	C _D =1.0	C _D =1.6
TB1460S	2 3/8" (60)	2x	54 (16)	195	195	210	335
			68 (14)	225	225	210	335
			97-312 (12 - 5/16")	245	390	215	345
TB1475S	3" (75)	2x	54 (16)	195	195	210	335
			68 (14)	225	225	210	335
			97-312 (12 - 5/16")	245	390	215	345

- For use with structural steel members up to 5/16" thick or cold-formed steel members 54 mil (16 ga.) or thicker.
- Standard product available in a black phosphate, yellow zinc or N2000 coating for additional corrosion protection (TBG1460S or TBG1475S).
- For use with 2x (1 1/2") DF/SP only.
- For use with Quik Drive HSD60 or HSD75 Tool.
- Use increased allowable loads (C_D = 1.6) only when resisting wind or seismic forces.

WARNING: Industry studies show that hardened fasteners can experience performance problems in wet or corrosive environments. Accordingly, use this product in dry, interior, and noncorrosive environments only.

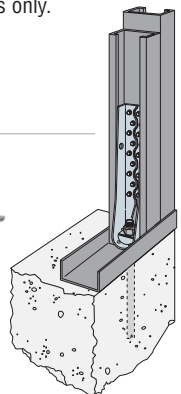

Designing with Steel?

If you are designing a structure using Cold-Formed Steel, comprehensive design information on using connectors, Simpson Strong-Tie anchoring products and Quik Drive® screws in your project can be found in the latest issue of the Simpson Strong-Tie Cold-Formed Steel Connectors catalog. You can access this information via the web at www.strongtie.com.

Have you tried our new Simpson Strong-Tie® CFS Designer™ software? It gives cold-formed steel (CFS) Designers the ability to design CFS beam-column members according to AISI specifications and to analyze complex beam loading and span conditions. To learn more, visit www.strongtie.com.



STRONG-DRIVE® SDS HEAVY-DUTY CONNECTOR Screw

The Simpson Strong-Tie® Strong-Drive® SDS Heavy-Duty Connector screw is a ¼" diameter structural wood screw ideal for various connector installations as well as wood-to-wood applications. It installs with no predrilling and has been extensively tested in various applications. The SDS Heavy-Duty Connector screw is improved with a patented easy driving 4CUT™ point and a corrosion resistant double-barrier coating.

The #8x1¼" SD Wafer-Head screw is ideal for miscellaneous fastening applications. The needle point ensures fast starts and deep #2 Phillips drive reduces cam-out and stripping.

SDS FEATURES:

- The patented 4CUT point has a square core and serrated threads to reduce installation torque and make driving easier with no predrilling and minimal wood splitting.
- Available with a double-barrier coating or in Type 316 stainless steel. Carbon steel loads apply to corresponding stainless steel models.
- ¾" hex washer head is stamped with the No-Equal sign and fastener length for easy identification after installation.

MATERIAL: Heat-treated carbon steel, Type 316 stainless steel

FINISH: SD8x1.25—Electro Galvanized;
SDS—Double Barrier (all lengths);
SDS—Type 316 Stainless Steel (1½" thru 3½" lengths)

CODES: See page 12 for Code Reference Key Chart.

WARNING: Industry studies show that hardened fasteners can experience performance problems in wet or corrosive environments. Accordingly, the SD8x1.25 should be used in dry, interior, and noncorrosive environments only.

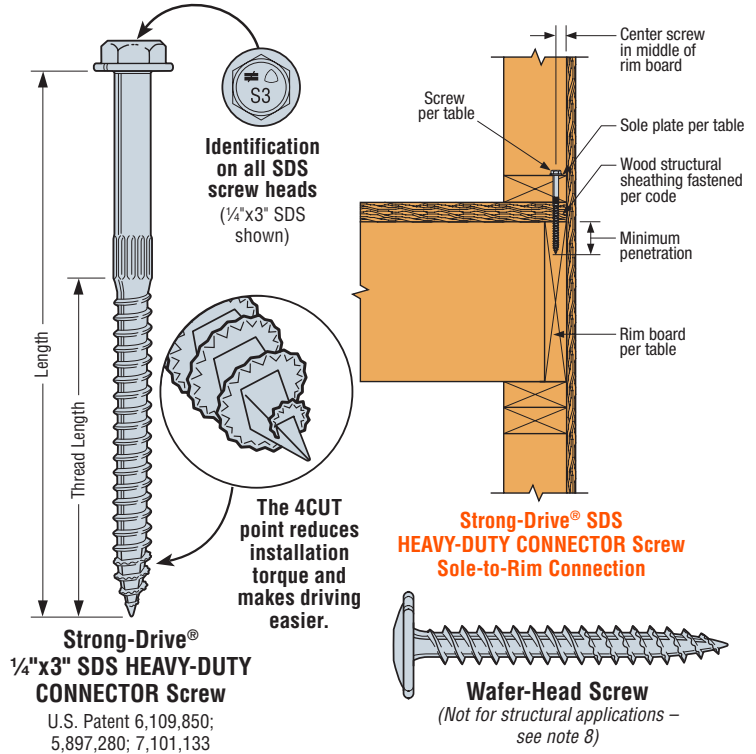

These products feature additional corrosion protection. Additional products on this page may also be available with this option, check with Simpson Strong-Tie for details.

Simpson Strong-Tie® Strong-Drive® SDS HEAVY-DUTY CONNECTOR Screw and Wafer-Head Screw

Size (in.)	Model No.	Thread Length (in.)	Fasteners per Carton ⁶	DF/SP Allowable Loads ⁴					SPF/HF Allowable Loads ⁴					Code Ref.		
				Shear (100) ¹				Withdrawal ⁵ (100)	Shear (100)				Withdrawal ⁵ (100)			
				Wood Side Plate ³		Steel Side Plate			Wood Side Plate ³		Steel Side Plate					
1½"	1¾" SCL	16 ga	14 ga & 12 ga	10 ga or Greater	Wood or Steel Side Plate	1½"	1¾" SPF LVL	16 ga	14 ga & 12 ga	10 ga or Greater	Wood or Steel Side Plate					
5/8 x 1 1/4	SD8x1.25 ⁸	—	—	—	—	50	50	50	—	—	—	45	45	45	—	170
1/4 x 1 1/2	SDS25112	1	1500	—	—	250	250	250	170	—	—	180	180	180	120	I5, L1, F20
1/4 x 2	SDS25200	1 1/4	1300	—	—	250	290	290	215	—	—	180	210	210	150	
1/4 x 2 1/2	SDS25212	1 1/2	1100	190	—	250	390	420	255	135	—	180	280	300	180	
1/4 x 3	SDS25300	2	950	280	—	250	420	420	345	200	—	180	300	300	240	
1/4 x 3 1/2	SDS25312	2 1/4	900	340	340	250	420	420	385	245	245	180	300	300	270	
1/4 x 4 1/2	SDS25412	2 3/4	800	350	340	250	420	420	475	250	245	180	300	300	330	
1/4 x 5	SDS25500	2 3/4	500	350	340	250	420	420	475	250	245	180	300	300	330	
1/4 x 6	SDS25600	3 1/4	600	350	340	250	420	420	560	250	245	180	300	300	395	
1/4 x 8	SDS25800	3 1/4	400	350	340	250	420	420	560	250	245	180	300	300	395	

Simpson Strong-Tie® Strong-Drive® SDS HEAVY-DUTY CONNECTOR Screw – Allowable Shear Values for Sole-to-Rim Connections

Size (in.)	Model No.	Sole Plate Nominal Size	Minimum Penetration into Rim Board (in.)	Allowable Loads								Code Ref.
				2x DF/SP Rim Board		2x SPF/HF Rim Board		1 1/4" Minimum LVL Rim Board		1 1/4" Minimum LSL Rim Board		
				DF/SP Sole Plate	SPF/HF Sole Plate	DF/SP Sole Plate	SPF/HF Sole Plate	DF/SP Sole Plate	SPF/HF Sole Plate	DF/SP Sole Plate	SPF/HF Sole Plate	
1/4 x 4 1/2	SDS25412	2x	2	250	190	190	190	190	190	220	190	I5, L1, F20
1/4 x 5	SDS25500	2x	2	250	190	190	190	190	190	220	190	
1/4 x 6	SDS25600	2x or 3x	2	250	190	190	190	190	190	220	190	

1. Screws may be provided with the 4CUT or Type 17 point.
2. Strong-Drive® SDS Heavy-Duty Connector screws install best with a low speed ½" drill with a ¾" hex head driver.
3. Values are valid for connections between two members with full thread penetration into the main member. For other wood side plate values, see *Fastening Systems catalog (C-F-14) pages 317-321*.
4. Allowable loads are shown at the wood load duration factor of C_D = 1.00. Loads may be increased for load duration per the building code up to a C_D = 1.60.
5. Withdrawal loads shown are in pounds (lbs.) and are based on the entire threaded section installed into the main member. If thread penetration into the main member is less than the Thread Length as shown in the table, reduce allowable load by 172 lbs. x inches of thread not in main member. Use 121 lbs./inch for SPF.

6. Fasteners per Carton represent the quantity of screws that are available in bulk packaging. Screws are also available in mini bulk and retail packs. Refer to Simpson Strong-Tie® *Fastening Systems catalog (C-F-14)*.
7. LSL wood-to-wood applications that require 4½", 5", 6" or 8" SDS screws are limited to interior-dry use only.
8. SD8x1.25 requires ¼" minimum penetration. DO NOT USE SD8x1.25 wood screws with structural connectors unless specified and stated in this catalog.
9. Where predrilling is required for Strong-Drive® SDS Heavy-Duty Connector screws, predrill diameter is 5/8".
10. Minimum spacing, edge, and end distance requirements are listed in ICC-ES ESR-2236. For smaller requirements, please contact Simpson Strong-Tie engineering.

STRONG-DRIVE® SD CONNECTOR Screw

Simpson Strong-Tie offers the Strong-Drive® SD Connector screw for use with our connectors. Designed to replace nails in certain products, the load-rated Strong-Drive® SD Connector screw has been tested and approved for use in many popular Simpson Strong-Tie® connectors. In certain applications screws are easier and more convenient to install than nails, and the single-fastener load values achieved by the SD9 and SD10 exceed those of typical 10d common or 16d common nails, respectively. In addition, the galvanized coating makes the Strong-Drive® SD Connector screw ideal for interior and most exterior conditions.



The Strong-Drive® SD Connector screw features an optimized shank, specifically designed for capability with the fastener holes in Simpson Strong-Tie connectors. The hex head virtually eliminates cam-out and helps avoid stripping of the head during installation. The sharp point of the screw enables fast starts, and the patented serrated threads reduce torque for improved drivability.

FEATURES:

- Tested and approved for use in many of our best-selling connectors for both interior and most exterior applications
- The single-fastener steel-side-plate load capacity of the SD9 exceeds the capacity of a 10d common nail, while the single-fastener load capacity of the SD10 exceeds that of the 16d common nail
- Ideal for use in tight spaces where using a hammer is inconvenient
- Optimized heat-treating for ductility and strength
- Mechanically galvanized coating meets ASTM B695 Class 55, is recommended for use with certain preservative-treated woods and recognized as an alternate to hot-dip galvanized in ESR-3046. It is compliant with the 2006, 2009, and 2012 International Residential Code® (2006 Section R319.3, 2009 and 2012 Section R317.3.1)
- ¼" hex drive included
- Head identification

MATERIAL: Heat-treated carbon steel

FINISH: Mechanically galvanized (ASTM Class 55)

CODES: See page 12 for Code Reference Key Chart.

These products feature additional corrosion protection.

Product Information

Model No.	Shank Size	Length (in.)
SD9112R100	#9 (0.131")	1½
SD9112R500		
SD9112MB		2½
SD9212R100		
SD9212R500		
SD9212MB	#10 (0.161")	1½
SD10112R100		
SD10112R500		2½
SD10112MB		
SD10212R100		
SD10212R500		
SD10212MB		

Strong-Drive® SD10 CONNECTOR Screw

(SD9 similar)
U.S. Patent 7,101,133

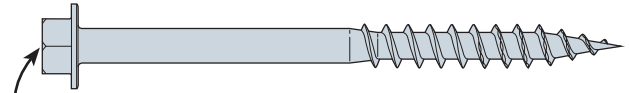

Identification on all SD screw heads
(SD10212 shown)



Since testing of the Strong-Drive® SD Connector screw is ongoing, Simpson Strong-Tie continues to add connectors to the approved-connector list. For the most current list of approved connectors, load values and applications, visit www.strongtie.com/strongdrive.

Simpson Strong-Tie has evaluation report approval for most of our Strong-Drive® SD Connector screws. Check with your local building department to determine whether the correct size of Strong-Drive® SD Connector screw may be used as a suitable substitute for nails.

Size (in.)	Model No.	Thread Length (in.)	DF/SP Allowable Loads (100)		SPF/HF Allowable Loads (100)		Code Ref.
			Shear	Withdrawal	Shear	Withdrawal	
			Steel Side Plate		Steel Side Plate		
			20 ga - 12 ga		20 ga - 12 ga		
#9x1½	SD9112	1	171	173	112	122	I24, I27, F31, L5, L24
#9x2½	SD9212	1	200		112		
#10x1½	SD10112	1	173	173	138	122	
#10x2½	SD10212	1	215		165		

1. Withdrawal loads and steel-side-plate shear loads are based on testing per AC233.
2. Allowable loads are shown at the wood load duration factor of C_D=1.00. Loads may be increased for load duration per the building code up to a C_D=1.60.
3. Withdrawal loads are based on the entire threaded section installed into the main member.
4. Visit www.strongtie.com for wood-to-wood shear values and wood-side-plate details.

UFP Universal Foundation Plate

The UFP provides a retrofit method to anchor the mudsill to the side of the foundation in applications where minimum vertical clearance exists. The UFP is also designed to perform when the mudsill is offset from the foundation up to 2 1/2" or extended beyond the foundation up to 1/2".

The UFP may be used in place of the FA, HFA and FAP connectors.

MATERIAL: 14 gauge

FINISH: Galvanized. May be ordered HDG, contact Simpson Strong-Tie. See Corrosion Information, pages 13-15.

INSTALLATION: • Use all specified fasteners; see General Notes.

- Loads are based on test results using Simpson Strong-Tie® Strong-Drive® 1/4"x3" SDS Heavy-Duty Connector screws, which are supplied with the UFP10.
- Alternate lag screws will not achieve published loads.

CODES: See page 12 for Code Reference Key Chart.

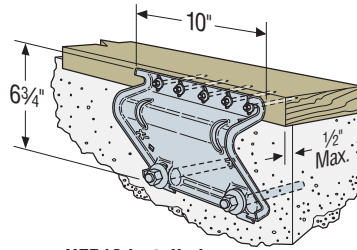

UFP10 installed on a Straight Foundation with 1/2" Offset Mudsill

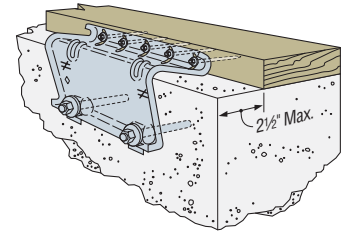

UFP10 installed on a Straight Foundation

U.S. Patent
5,732,519

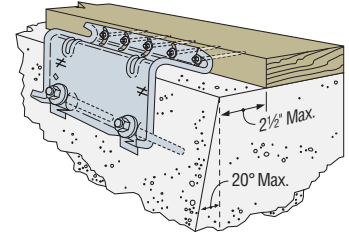

UFP10 installed on a Trapezoid Foundation

These products are available with additional corrosion protection. Additional products on this page may also be available with this option, check with Simpson Strong-Tie for details.

Model No.	Max Spacing to replace Anchor Bolt 1/2" or 5/8" dia.	Fasteners			Allowable Load DF/SP Parallel to Plate (160)	Code Ref.
		Anchor Bolt Qty.	Anchor Bolt Dia.	Plate		
UFP10-SDS3	6'	2	1/2"	5-SDS 1/4"x3"	1340	I20, L10, F19

1. Allowable loads have been increased for wind or earthquake loading with no further increase allowed; reduce where other load durations apply.
2. Each anchor bolt requires a standard cut washer, see technical bulletin T-ANCHORSPEC for more information.
3. Designer must specify anchor bolt type, length and embedment.

FAP/FJA/FSA Foundation Anchors

The FAP Plate connects the mudsill to the foundation, and is designed to provide lateral load resistance.

The FJA Foundation Joist Anchor nails or bolts directly into floor joists, providing a direct connection between the foundation and joist to resist uplift and lateral forces. FSA Foundation Stud Anchor nails or bolts to floor joists, or nails to the stud. Plywood sheathing may require notching with stud-to-foundation installation. See technical bulletin T-ANCHORSPEC for anchoring solutions.

MATERIAL: FAP—7 gauge; all others—12 gauge

FINISH: Galvanized. May be ordered HDG, contact Simpson Strong-Tie. See Corrosion Information, pages 13-15.

INSTALLATION:

- Use all specified fasteners; see General Notes.
- **FJA and FSA** may be bent along bend line up to 20° to accommodate installation. Bend one time only.

CODES: See page 12 for Code Reference Key Chart.

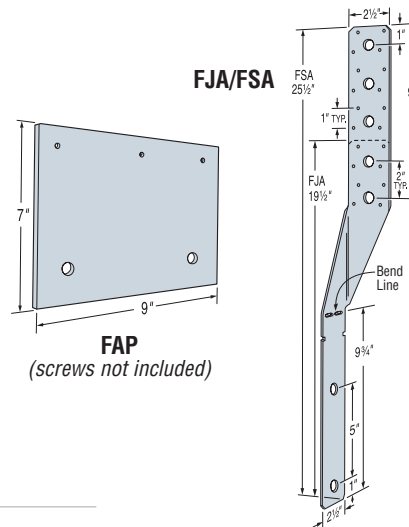

FAP
(screws not included)

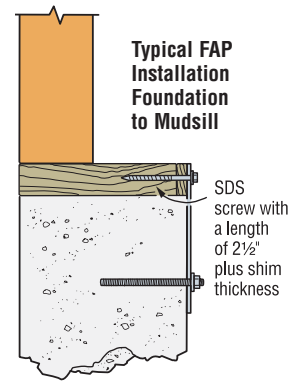

Typical FAP Installation Foundation to Mudsill

Add a shim between plate and sill when space is between 3/16" and 1 1/2". When space exceeds 1 1/2" use the UFP. The shim must be fastened to the mudsill by means other than the FAP SDS wood screw.

These products are available with additional corrosion protection. Additional products on this page may also be available with this option, check with Simpson Strong-Tie for details.

Model No.	Max Spacing to Replace Anchor Bolts		Anchor Bolt		Stud/Joist/Plate	Allowable Loads DF/SP (160)			Code Ref.
	1/2"	5/8"	Qty.	Dia.		Uplift	F ₁	F ₂	
FAP	5 1/2'	4'	2	1/2"	3-SDS 1/4"x2 1/2" + shim thickness	—	950	365	—
FJA	—	—	2	1/2"	8-10dx1 1/2"	1205	185	60	I20, L10, F19
					2-1/2"MB	690	185	60	
FSA	—	—	2	1/2"	8-10dx1 1/2"	1205	—	—	—
					2-1/2"MB	690	—	—	

1. Allowable loads have been increased for wind or earthquake loading with no further increase allowed; reduce where other load durations govern.
2. For redwood mudsills, reduce F₁ on FAP to 840 lbs.
3. Spacing to be specified by the Designer.
4. FAP shall use a minimum Strong-Drive® SDS Heavy-Duty Connector screw length of 2 1/2" plus the shim thickness.
5. The shim must be fastened to the mudsill by means other than the FAP Strong-Drive® SDS Heavy-Duty Connector screw.
6. FAP may be installed with 1/4" HDG lag bolts. Follow code requirements for predrilling.
7. **NAILS:** 10dx1 1/2" = 0.148" dia. x 1 1/2" long. See pages 22-23 for other nail sizes and information.

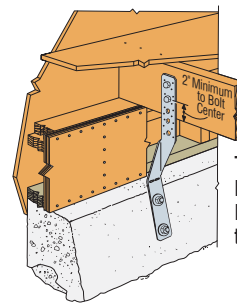

Typical FSA Installation Foundation to Joist

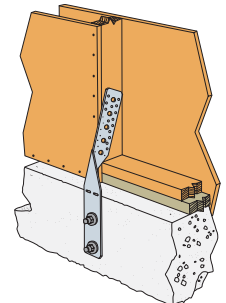

Typical FSA Installation Foundation to Stud

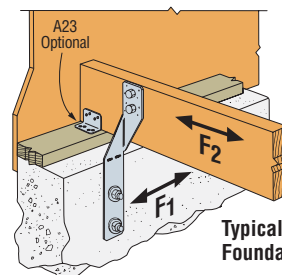

Typical FJA Installation Foundation to Joist

MASA/MASAP Mud sill Anchors



This product is preferable to similar connectors because of a) easier installation, b) higher loads, c) lower installed cost, or a combination of these features.

Mudsill anchors have always been a time-saving alternative to anchor bolts, and the MASA anchors provide even greater load-carrying capacity alternative for 3/8" and 1/2" mudsill anchor bolts on 2x, double-2x and 3x mudsills. It also eliminates the need for 3" square plate washers for seismic design and, in some cases, has load capacities that meet or exceed the parallel and perpendicular to plate shear capacity of other cast-in-place anchors. Two versions of the MASA are available – the standard MASA for installation on standard forms and the MASAP for panelized forms.

The MASA and MASAP are code listed by ICC-ES under the 2006, 2009 and 2012 IBC® and IRC® and have been tested to meet the requirements of ICC-ES acceptance criteria AC-308 for cracked and uncracked concrete.

MATERIAL: 16 gauge

FINISH: Galvanized, all available in ZMAX® coating.

See Corrosion Information, pages 13-15.

INSTALLATION: • Use all specified fasteners. See General Notes.

• **MASA/MASAP**

- Concrete shall have a minimum $f'_c = 2500$ psi.
- Spalling—Full loads apply for spalls up to a maximum height of 1 1/4" and a maximum depth of 7/8". Any exposed portion of the mudsill anchor must be protected against possible corrosion.
- For prescriptive anchor spacing refer to page 30.
- Testing shows that these mudsill anchors can be used in lieu of code required anchor bolts and square washer in high seismic zones. Refer to flier F-MASA for additional information.
- Minimum MASA end distance is 4" and minimum center-to-center spacing is 8" for full load.
- For continuous load path, MASA should be installed on the same side of wall as uplift connectors.

CODES: See page 12 for Code Reference Key Chart.

ICC-ES ESR-2555, City of L.A. RR 25851; Florida FL13326

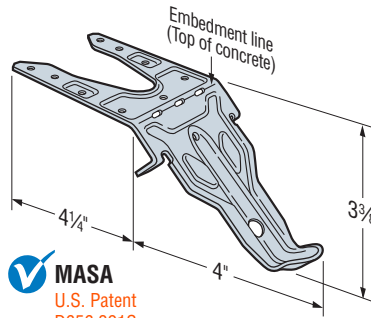

MASA
U.S. Patent
D656,391S

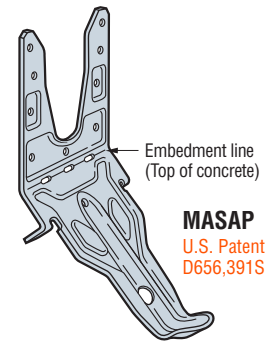

MASAP
U.S. Patent
D656,391S

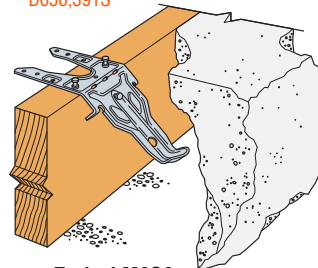

Typical MASA Installation in Concrete

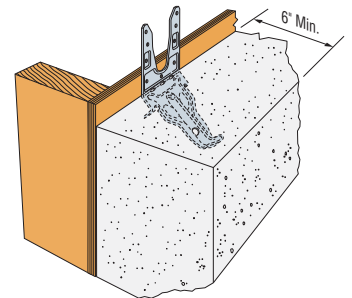

Typical MASAP Installation in Concrete

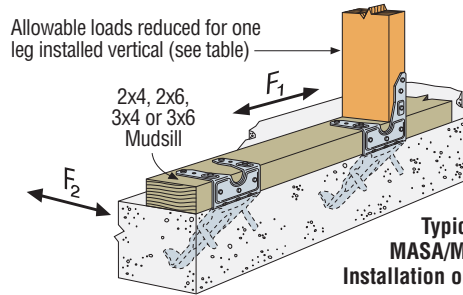

Typical MASA/MASAP Installation on Sill Plate

Allowable loads reduced for one leg installed vertical (see table)

These products are available with additional corrosion protection. Additional products on this page may also be available with this option, check with Simpson Strong-Tie for details.

Model No.	Sill Size	Fasteners		Allowable Loads												Code Ref.
		Sides	Top	Non Cracked						Cracked						
				Uplift	F ₁	F ₂	Uplift	F ₁	F ₂	Uplift	F ₁	F ₂	Uplift	F ₁	F ₂	
STANDARD INSTALLATION – Attached to DF/SP Sill Plate																
MASA or MASAP	2x4, 2x6	3-10dx1 1/2	6-10dx1 1/2	920	1515	1095	745	1235	1045	785	1515	910	660	1235	765	I22, L22, F29
	3x4, 3x6	5-10dx1 1/2	4-10dx1 1/2	650	1215	725	550	1020	725	495	1215	725	415	1020	640	
ONE LEG UP INSTALLATION – Attached to DF/SP Sill Plate																
MASA or MASAP	2x4, 2x6	6-10dx1 1/2	3-10dx1 1/2	785	1005	995	660	845	995	595	1005	965	500	845	810	I22, L22, F29
	3x4, 3x6	7-10dx1 1/2	2-10dx1 1/2	—	815	—	—	685	—	—	815	—	—	685	—	
TWO LEGS UP INSTALLATION – Attached to DF/SP Sill Plate and Rimboard																
MASA or MASAP	2x4, 2x6	9-10dx1 1/2	—	810	1150	900	740	965	755	665	1150	660	560	965	550	I22, L22, F29
DOUBLE 2x INSTALLATION – Attached to DF/SP Sill Plate																
MASA or MASAP	Dbl 2x4, Dbl 2x6	5-10dx1 1/2	2-10dx1 1/2	875	1075	785	735	900	785	660	1075	785	555	900	785	I22, L22
STANDARD INSTALLATION – Attached to Hem Fir Sill Plate																
MASA or MASAP	2x4, 2x6	3-10dx1 1/2	6-10dx1 1/2	790	1305	940	640	1060	900	675	1305	785	570	1060	660	170
	3x4, 3x6	5-10dx1 1/2	4-10dx1 1/2	560	1045	625	475	875	625	425	1045	625	355	875	550	
ONE LEG UP INSTALLATION – Attached to Hem Fir Sill Plate and HF/SPF Stud																
MASA or MASAP	2x4, 2x6	6-10dx1 1/2	3-10dx1 1/2	675	865	855	565	725	855	510	865	830	430	725	695	170
	3x4, 3x6	7-10dx1 1/2	2-10dx1 1/2	—	700	—	—	590	—	—	700	—	—	590	—	
TWO LEGS UP INSTALLATION – Hem Fir Sill Plate and HF/SPF Rimboard																
MASA or MASAP	2x4, 2x6	9-10dx1 1/2	—	700	990	775	635	830	650	570	990	565	480	830	475	170
DOUBLE 2x INSTALLATION – Attached to Hem Fir Sill Plate																
MASA or MASAP	Dbl 2x4, Dbl 2x6	5-10dx1 1/2	2-10dx1 1/2	750	925	675	630	775	675	660	925	675	555	775	675	170

1. Loads are based on allowable stress design (ASD) and include the load duration factor C_D (with $C_D = 1.6$) for wind/earthquake loading. No further increase is allowed. Reduce where other loads govern.
2. Minimum concrete compression strength, f'_c is 2500 psi.
3. Allowable loads are based on a minimum stemwall width of 6".
4. For simultaneous loads in more than one direction, the connector must be evaluated using the Unity Equation.

5. Per Section 1613 of the 2009 and 2012 IBC, detached one- and two-family dwellings in SDC C may use the "Wind and SDC A&B" allowable loads.
6. For designs under the 2009 and 2012 IBC, sill plate size shall comply with the shearwall requirements of the 2008 Special Design Provisions for Wind and Seismic.
7. MASA/MASAP may be installed using 7-nails when being used to replace a 1/2" diameter sill bolt for use on a 2x mudsill. **Install minimum 3-side fasteners.**
8. **NAILS:** 10dx1 1/2" = 0.148" dia. x 1 1/2" long. See pages 22-23 for other nail sizes and information.

MASA/MASAP *Mudsill Anchors***Prescriptive Spacing for MASA/MASAP to Replace Sill Anchor Bolts**

Anchor Bolt Size	Anchor Bolt Spacing	DF/SP 2x Sill Plate		HF 2x Sill Plate	
		Wind & SDC A&B	SDC C - E	Wind & SDC A&B	SDC C - E
½" Diameter	6' o.c.	6'-0"	6'-0"	6'-0"	6'-0"
	4' o.c.	4'-0"	4'-0"	4'-0"	4'-0"
⅝" Diameter	6' o.c.	5'-7"	4'-7"	5'-4"	4'-4"
	4' o.c.	3'-9"	3'-1"	3'-6"	2'-11"

1. "Prescriptive" denotes designs per the IRC or conventional provisions of the IBC for wind speeds 100 mph or less, or for Seismic Design Category D and less (SDC E and less in IBC).
2. Detached one- and two-family dwellings in SDC C may use the "Wind & SDC A&B" spacing.
3. Spacing is based on the parallel to plate load direction for MASA Standard installation only.
4. ⅝" diameter AB required in SDC E.
5. When replacing ½" diameter sill bolts use 7-10dx1½" nails for standard installation.
1 out of 3 MASAs (33%) may be installed in One Leg Up installation along a wall line.
6. When replacing ⅝" diameter sill bolts use 9-10dx1½" nails for standard installation.
1 out of 5 MASAs (20%) may be installed in One Leg Up installation along a wall line.
7. Per Section 1613 of the 2009/2012 IBC, detached one- and two-family dwellings in SDC C may use the "Wind & SDC A&B" spacing.

ALTERNATIVE MUDSILL ANCHOR INSTALLATIONS**ALTERNATE INSTALLATION FOR INSIDE OF WALL CONTINUITY**

Full catalog loads apply.

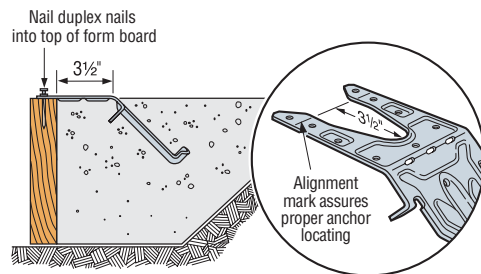

- 1 STEP 1:** Attach MASA 3½" from inside of form. After concrete cures, remove nails and bend straps up 90°

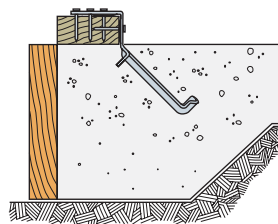

- 2 STEP 2:** Place mudsill on concrete and nail MASA over mudsill

ALTERNATE INSTALLATION FOR BRICK LEDGES

Full catalog loads apply.

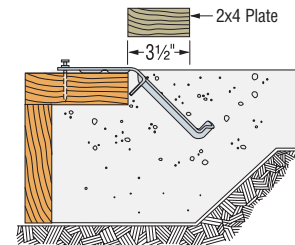

Alternate MASA Installation for Brick Ledges

ALTERNATE INSTALLATION FOR RIM JOIST OR BLOCKING

Blocking required attached to sill with A35Z (not shown) or per Designer

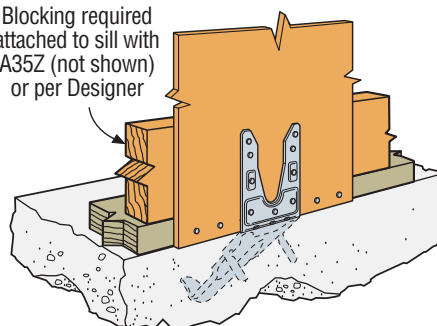

Max. ½" Sheathing

LMAZ/MA/MAB/MASB Mud sill Anchors

Mud sill anchors provide an alternative to anchor bolts. They easily mount on forms and make finishing easier. The unique design provides installation flexibility, eliminating problems with misplaced anchor bolts. Suitable for stem wall or slab foundations, mud sill anchors are one piece so there are no more nuts and washers to lose.

- LMAZ—an economical replacement for 1/2" sill plate anchor bolts
- MA—for slab or stem wall construction
- MAB—anchors mudsill to concrete block, poured walls or slab foundations

MATERIAL: LMAZ, MAB—18 gauge; MA/MASB—16 gauge
FINISH: MA, MAB, MASB—Galvanized (some available in ZMAX® coating); LMAZ—ZMAX only. See Corrosion Information, pages 13-15.

INSTALLATION: • Use all specified fasteners. See General Notes.

• **LMAZ/MA/MAB:**

- CMU shall have a minimum $f'_m = 1500$ psi and concrete shall have a minimum $f'_c = 2000$ psi.
- Not for use where a horizontal cold joint exists between the slab and foundation wall or footing beneath, unless provisions are made to transfer the load.
- Not for use in slabs poured over foundation walls formed of concrete block or with brick and 4" masonry block stemwalls.

• **MASB:**

- Fill CMU cell with concrete grout first, then place MASB into the grouted cell and adjust into position. Attach mudsill to anchor only after the concrete grout cures.
- CMU shall have a minimum $f'_m = 1500$ psi.
- The MASB Mud sill Anchors were tested in standard 8" CMU.

CODES: See page 12 for Code Reference Key Chart.

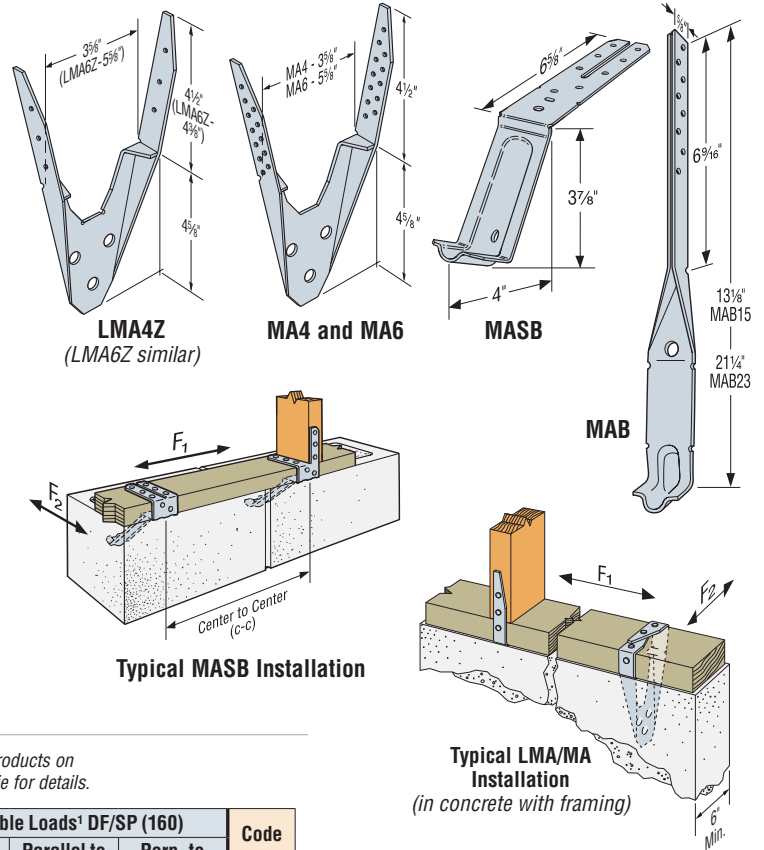

These products are available with additional corrosion protection. Additional products on this page may also be available with this option, check with Simpson Strong-Tie for details.

Model No.	Sill Size	Fasteners		Allowable Loads ¹ DF/SP (160)			Code Ref.
		Sides	Top	Uplift ²	Parallel to Plate (F ₁)	Perp. to Plate (F ₂)	
MASB (Standard)	2x4,6	2-10dx1½	6-10dx1½	130	930	410	170
MASB (One Leg Up)	2x4,6	3-10dx1½	4-10dx1½	—	960	360	
LMA4Z	2x4	2-10dx1½	4-10dx1½	905	675	520	170
	3x4	4-10dx1½	2-10dx1½	905	675	520	
LMA6Z	2x6	2-10dx1½	4-10dx1½	905	825	650	170
	3x6	4-10dx1½	4-10dx1½	1110	825	650	
MA4	2x4	2-10dx1½	2-10dx1½	830	575	430	170
	3x4	4-10dx1½	2-10dx1½	915	680	430	
MA6	2x6	2-10dx1½	4-10dx1½	915	680	430	170
	3x6	4-10dx1½	4-10dx1½	915	680	430	
MAB15	2x4,6	2-10dx1½	4-10dx1½	565	500	500	170
MAB23	2x4,6	2-10dx1½	4-10dx1½	565	500	500	

1. Loads have been increased for short-term loading.
2. For uplift loads, provide attachment from mudsill to building's structural components to prevent cross-grain bending.
3. MA installed attached to the stud has no load reduction for parallel loads, has a perpendicular load of 670 lbs. and an uplift of 835 lbs.
4. LMAZ installed attached to the stud has no load reduction for parallel and perpendicular loads and an uplift of 600 lbs. for LMA4 and 835 lbs. for LMA6.
5. For concrete stemwall applications, allowable loads are based on a minimum concrete stemwall width of 6".
6. **NAILS:** 10dx1½ = 0.148" dia. x 1½" long. See pages 22-23 for other nail sizes and information.

Prescriptive Anchor Spacing

Model No.	O.C. Spacing To Replace 1/2" Anchor Bolt 6' O.C. (160)	O.C. Spacing To Replace 3/8" Anchor Bolt 6' O.C. (160)	Minimum Concrete End Distance	Minimum C-C Spacing
MASB	5'-6"	4'-8"	3¾"	7½"
LMA4Z	3'-8"	2'-7"	4¾"	9¼"
LMA6Z	4'-6"	3'-2"		
MA4	3'-2"	2'-2"	4¾"	9¼"
MA6	3'-9"	2'-7"		
MAB15	2'-9"	1'-11"	6½"	13"
MAB23	2'-9"	1'-11"	12"	24"

1. "Prescriptive" denotes designs per the IRC or conventional provisions of the IBC for wind speeds 100 mph or less, or for Seismic Design Category D and less (SDC E and less in IBC).
2. Spacing is based on parallel to plate load direction only.
3. Place anchors not more than 12" from the end of sill and splices per code.
4. CMU shall have a minimum $f'_m = 1500$ psi and concrete shall have a minimum $f'_c = 2500$ psi.
5. Spacings apply to DF, SP, and HF sill plates.

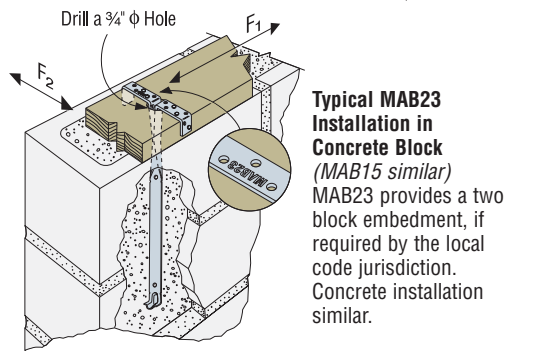
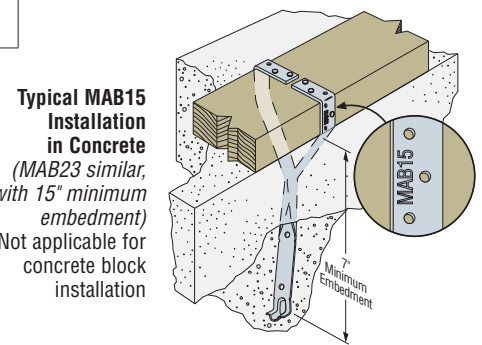
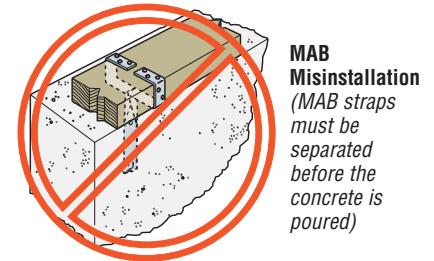

FWAZ/FWANZ Foundation Wall Angle

FWA foundation anchors connect the foundation or basement walls to the floor system to resist out-of-plane forces imposed by soil pressure. The FWAZ attaches through the mudsill into the foundation using the Simpson Strong-Tie® Titen HD® heavy-duty screw anchor, eliminating the need for separate anchor bolts into the rim joist. The FWANZ fastens to the mudsill with nails, relying on other anchorage (by Designer) to anchor the rim joist to the foundation. The spacing of the FWA anchors is independent of the joist spacing, allowing for a multitude of options based on soil pressures.

Special Features:

- Compatible with solid sawn joists, I-joists and floor trusses.
- Testing performed on most common rim materials and types.
- Addresses design needs set forth in Section 1610.1 in the IBC and Section R404 in the IRC.
- Eliminates the need of costly cantilevered foundation designs.

MATERIAL: 14 gauge

FINISH: ZMAX® coating. See Corrosion Information, pages 13-15.

INSTALLATION: • Use all specified fasteners. See General Notes.

- Connectors must be fastened directly to the outside face of the rim board with 5-10dx1½ (0.148" dia. x 1½") long nails.
- Connectors must be located within 4" of adjacent joist/blocking for floor joist spacing up to 48" o.c. and may be centered between joists/blocking for 16" o.c. floor joist spacing.
- When floor joists are parallel to the rim board, full depth blocking shall be used in the first two bays of the floor per 2006 IRC Section R404.1.
- Splice joint not permitted on rim board in same bay unless blocking is placed on both sides of the splice. The maximum sill plate thickness to be used for the FWAZ only shall be 1½".
- FWAZ only—must be anchored to the foundation wall with ½"x6" mechanically galvanized Titen HD heavy-duty screw anchor (included).
- Cast-in-place anchor bolts may not be used as a substitute.
- When I-joist rim material is used, backer blocks must be used. Installed per manufacturer's recommendations.

CODES: See page 12 for Code Reference Key Chart. Refer to IBC 1610.1.

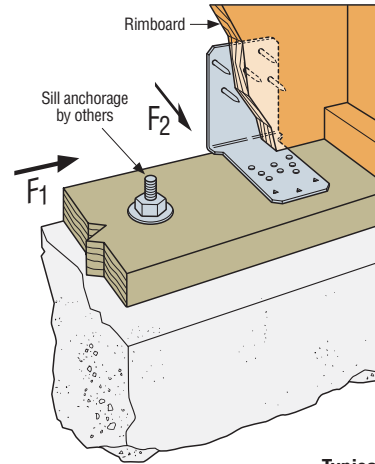
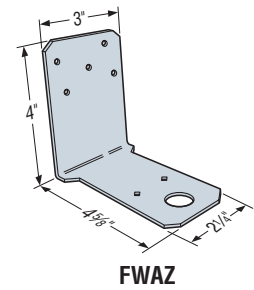
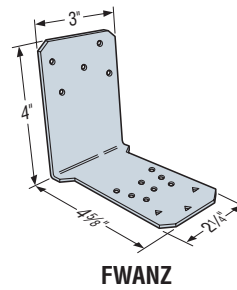

Typical FWANZ Installation

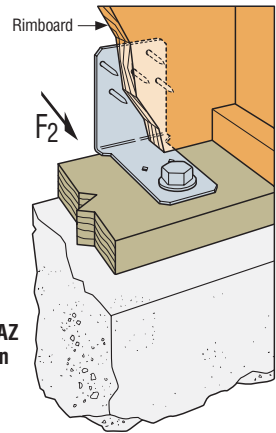

Typical FWAZ Installation

These products are available with additional corrosion protection. Additional products on this page may also be available with this option, check with Simpson Strong-Tie for details.

Model No.	Fasteners		Foundation Wall Thickness	Rim Board Material	Allowable Lateral F ₂ Loads				Code Ref.
	Rim	Concrete			Concrete f'c=2500 psi	Concrete f'c=3000 psi	Concrete f'c=4000 psi	CMU f'm=1500 psi	
FWAZ	5-10dx1½	1-½"x6" Titen HD Anchor (Included)	6"	1" OSB Rim	705	705	705	—	170
				1¾" I-joist Rim	880	880	880		
				1½" OSB Rim	880	880	880		
				2x Rim	880	880	880		
				1¼" LSL Rim	880	880	880		
				1¾" LVL Rim	880	880	880		
			8"	1" OSB Rim	705	705	705	615	
				1¾" I-joist Rim	880	1000	1000		
				1½" OSB Rim	880	1050	1050		
				2x Rim	880	1055	1170		
				1¼" LSL Rim	880	1055	1280		
				1¾" LVL Rim	880	1055	1280		

1. Lateral (F₂) loads are based on load duration factor C_D = 0.90 with no further increase allowed.
2. FWAZ spacing shall be per Designer.
3. FWAZ must be located within 4" of adjacent joist/blocking for floor joist spacing up to 48" o.c. and may be centered between joists/blocking for 16" o.c. floor joist spacing.
4. Maximum sill plate thickness shall be 1½".
5. The Titen HD heavy-duty screw anchor used in the FWAZ to resist the out-of-plane (F₂) forces may also be used to resist in-plane shear forces provided the Designer determines the Titen HD heavy-duty screw anchor allowable loads (refer to C-SAS catalog) and evaluates the combined loading condition with the published F₂ loads.
6. **NAILS:** 10dx1½ = 0.148" dia. x 1½" long. See pages 22-23 for other nail sizes and information.

Model No.	Sill Plate	Fastener (Quantity-Type)		Rim Board Material	Allowable F ₂ Load (DF/SP Sill Plate)			Allowable F ₂ Load (HF Sill Plate)			Code Ref.					
		Sill Plate	Rim Board		(90) ⁷	(100)	(160)	(90) ⁷	(100)	(160)						
FWANZ	2x4, 2-2x4, 3x4, 4x4	(8)	10dx1½	10dx1½	1" OSB Rim	895	895	895	815	895	895	IP1				
					1½" OSB Rim	945	970	970	815	905	970					
					1¾" I-Joist Rim	945	1050	1275	815	905	1275					
					1¼" LSL Rim	945	1050	1315	815	905	1315					
					2x Rim	945	1050	1410	815	905	1345					
					1¾" LVL Rim	945	1050	1485	815	905	1345					
					2x6, 2-2x6, 3x6, 4x6	(11)	10dx1½	10dx1½	1" OSB Rim	895	895		895	895	895	895
									1½" OSB Rim	1110	1110		1110	1110	1110	1110
	1¾" I-Joist Rim	1135	1135	1135					1120	1135	1135					
	1¼" LSL Rim	1220	1220	1220					1120	1220	1220					
	2x Rim	1300	1440	1445					1120	1245	1445					
	1¾" LVL Rim	1300	1440	1645					1120	1245	1645					

1. FWANZ may be used to transfer F₁ loads up to 310 lbs. No further increase in load permitted.
2. For simultaneous F₁ and F₂ loads, the connector must be evaluated using the unity equation (see page 18).
3. Designer shall evaluate rim board and sill plate design based on demand load.
4. FWANZ spacing and sill plate anchorage to be specified by the Designer.
5. FWANZ must be located within 4" of adjacent joist/blocking for floor joist spacing up to 48" o.c. and may be centered between joists/blocking for 16" o.c. floor joist spacing.
6. When floor joists are parallel to the rimboard, Designer must ensure proper load transfer from rimboard into diaphragm.
7. Values based on a load duration factor C_D = 0.90.
8. **NAILS:** 10dx1½ = 0.148" dia. x 1½" long. See pages 22-23 for other nail sizes and information.

SB Anchor Bolt



This product is preferable to similar connectors because of a) easier installation, b) higher loads, c) lower installed cost, or a combination of these features.

The SB $\frac{5}{8}$ x24 anchor bolt offers a load-tested anchorage solution that exceeds the capacity of all of our holdowns that call for a $\frac{5}{8}$ " dia. anchor. Similarly, the SB1x30 covers holdowns utilizing a 1" diameter anchor that exceed the capacity of our SSTB bolts. The SB $\frac{5}{8}$ x24 is designed to maximize performance with minimum embedment for holdowns utilizing a $\frac{7}{8}$ " dia. anchor.

SB anchor bolts are code listed by ICC-ES under the 2009 and 2012 IBC and IRC to meet the requirements of ICC-ES acceptance criteria – AC 399. ICC-ES ESR-2611 is the industry's first code report issued for proprietary anchor bolts evaluated to the criteria of AC 399.

Special Features:

- Identification on the bolt head showing embedment angle and model
- Sweep geometry to optimize position in form
- Rolled thread for higher tensile capacity
- Hex nuts and plate washer fixed in position
- Available in HDG for additional corrosion resistance

MATERIAL: ASTM F-1554, Grade 36

FINISH: None. May be ordered HDG. Contact Simpson Strong-Tie.

INSTALLATION:

- SB is only for concrete applications poured monolithically except where noted.
- Top nuts and washers for holdown attachment are not supplied with the SB; install standard nuts, couplers and/or washers as required.
- On HDG SB anchors, chase the threads to use standard nuts or couplers or use overlapped products in accordance with ASTM A563, for example Simpson Strong-Tie® NUT5/8-OST, NUT7/8-OST and NUT1-OST, CNW $\frac{5}{8}$ -OST, CNW $\frac{7}{8}$ -OST and CNW1-OST.
- Install SB before the concrete pour using AnchorMates®. Install the SB per the plan view detail.
- Minimum concrete compressive strength is 2500 psi.
- When rebar is required it does not need to be tied to the SB.

CODES: See page 12 for Code Reference Key Chart.

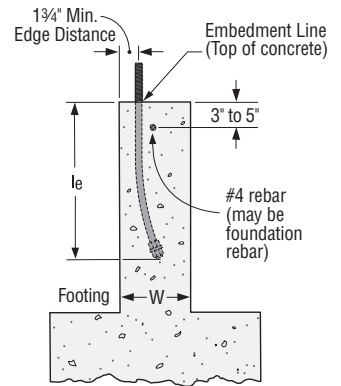
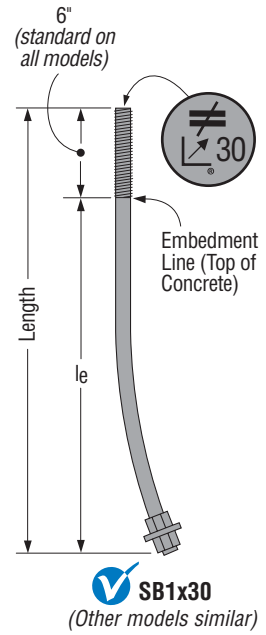

Typical SB Installation

SB Bolts at Stemwall

Model No.	Dimensions (in.)				Allowable Tension Loads						Code Ref.
	Stemwall Width	Dia.	Length	Min. Embed. (le)	Wind & SDC A&B			SDC C-F			
					Midwall	Corner	End Wall	Midwall	Corner	End Wall	
SB $\frac{5}{8}$ x24	6	$\frac{5}{8}$	24	18	6675	6675	6675	6675	5730	5730	I23, F30, L20
SB $\frac{7}{8}$ x24	8	$\frac{7}{8}$	24	18	10470	9355	6820	8795	7855	5730	
SB1x30	8	1	30	24	13665	9905	7220	11470	8315	6065	

1. See page 34 for notes to the Designer.

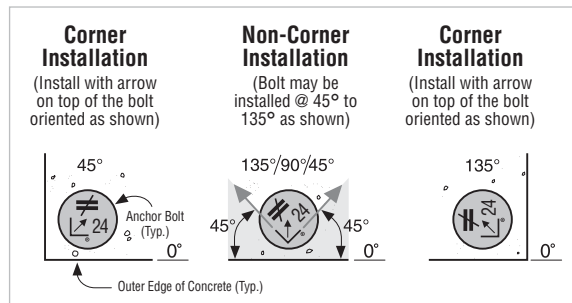
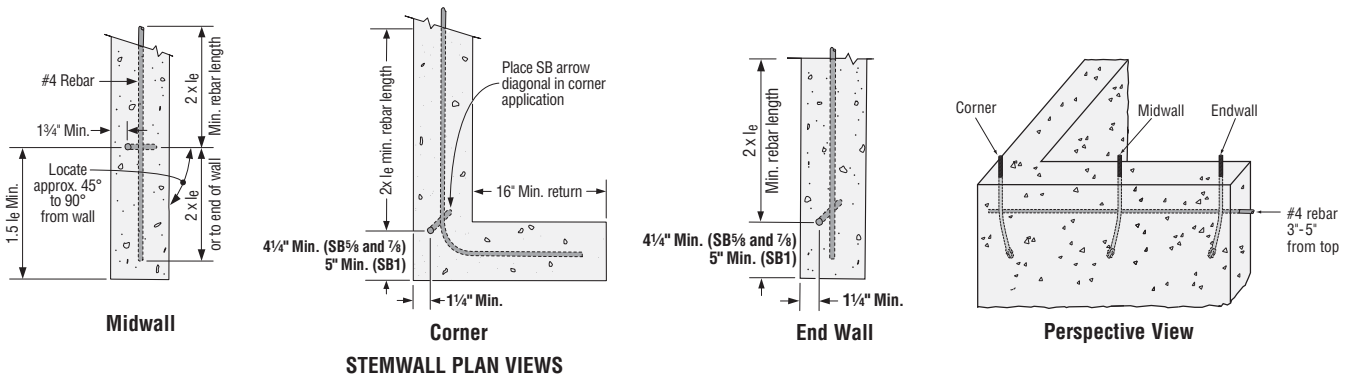

Plan View of SB Placement in Concrete

SB Anchor Bolt

SB Bolts at Stemwall: Garage Front

Model No.	Dimensions (in.)				Allowable Tension Loads				Code Ref.
	Stemwall Width	Dia.	Length	Min. Embed. (l_e)	Wind & SDC A&B		SDC C-F		
					Step-Down End	Corner	Step-Down End	Corner	
SB $\frac{7}{8}$ x24	8	$\frac{7}{8}$	24	18	7225	7660	6070	6435	123
SB1x30	8	1	30	24	11305	9635	9495	8030	

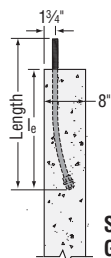

Stemwall Garage Front

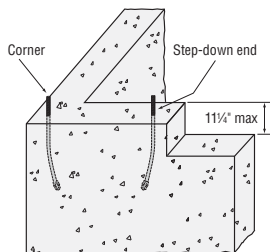

Perspective View

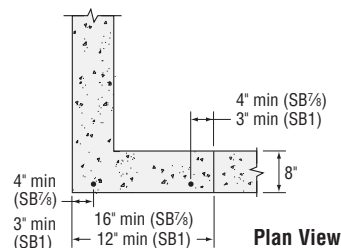

Plan View

SB Bolts at Slab on Grade: Edge

Model No.	Dimensions (in.)				Allowable Tension Loads				Code Ref.
	Footing Width	Dia.	Length	Min. Embed. (l_e)	Wind & SDC A&B		SDC C-F		
					Midwall	Corner	Midwall	Corner	
SB $\frac{7}{8}$ x24	12	$\frac{7}{8}$	24	18	6675	6675	6675	5730	123
SB $\frac{7}{8}$ x24	12	$\frac{7}{8}$	24	18	13080	12135	12320	10190	
SB1x30	12	1	30	24	17080	15580	16300	13090	

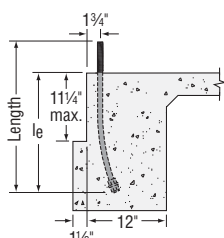

Slab Edge

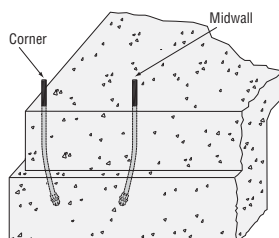

Perspective View

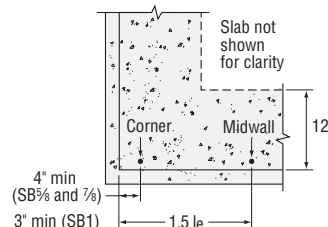

Plan View

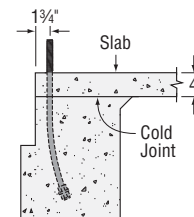

Two-Pour Installation

SB Bolts at Slab on Grade: Garage Curb

Model No.	Dimensions (in.)				Allowable Tension Loads				Code Ref.
	Curb Width	Dia.	Length	Min. Embed. (l_e)	Wind & SDC A&B		SDC C-F		
					Step-down End	Corner	Step-down End	Corner	
SB $\frac{7}{8}$ x24	6	$\frac{7}{8}$	24	18	9175	11075	7705	9305	123
SB1x30	6	1	30	24	15580	15580	13090	13090	

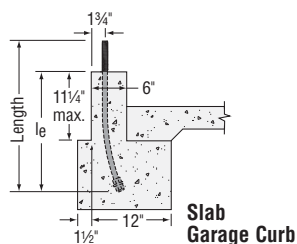

Slab Garage Curb

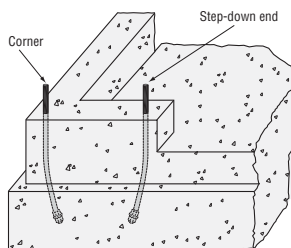

Perspective View

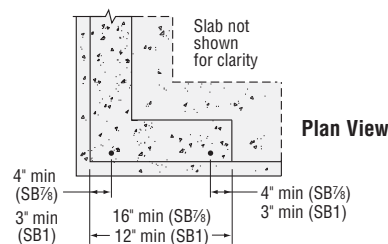

Plan View

Notes to the Designer:

1. Rebar is required at top of stemwall foundations but is not required for Slab-on-Grade Edge and Garage Curb, or Stemwall Garage Front installations.
2. Minimum end distances for SB bolts are as shown in graphics.
3. Multiply the tabulated ASD wind or seismic loads by 1.6 or 1.4, respectively, to obtain LFRD capacities.
4. Per Section 1613 of the IBC, detached one- and two-story dwellings in SDC C may use "Wind and SDC A&B" allowable loads.
5. See ESR-2611 for additional information.
6. Midwall loads apply when anchor is $1.5 l_e$ or greater from the end. For bolts acting in tension simultaneously, the minimum bolt center-to-center spacing is $3 l_e$.
7. Full catalog loads apply for two-pour installation for slab-on-grade: edge.

SSTB® Anchor Bolts



This product is preferable to similar connectors because of a) easier installation, b) higher loads, c) lower installed cost, or a combination of these features.

The SSTB anchor bolt is designed for maximum performance as an anchor bolt for holdowns and Simpson Strong-Tie® Strong-Wall® shearwalls. Extensive testing has been done to determine the design load capacity of the SSTB when installed in many common applications.

The Simpson Strong-Tie® SSTB anchor bolts are now code listed by ICC-ES under the 2009 and 2012 IBC® and IRC® to meet the requirements of ICC-ES acceptance criteria AC 399. ICC-ES ESR-2611 is the industry's first code report issued for proprietary anchor bolts evaluated to the criteria of AC 399.

Special Features:

- Identification on the bolt head showing embedment angle and model
- Offset angle reduces side bursting, and provides more concrete cover
- Rolled thread for higher tensile capacity
- Stamped embedment line aids installation
- Available in HDG for additional corrosion resistance

MATERIAL: ASTM F-1554, Grade 36

FINISH: None. May be ordered HDG; contact Simpson Strong-Tie.

INSTALLATION:

- SSTB is suitable for monolithic and two-pour concrete applications.
- Nuts and washers for holdown attachment are not supplied with the SSTB; install standard nuts, couplers and/or washers as required.
- On HDG SSTB anchors, chase the threads to use standard nuts or couplers or use overlapped products in accordance with ASTM A563, for example Simpson Strong-Tie® NUT $\frac{5}{8}$ -OST, NUT $\frac{7}{8}$ -OST, CNW $\frac{5}{8}$ -OST, CNW $\frac{7}{8}$ -OST.
- Install SSTB before the concrete pour using AnchorMates®. Install the SSTB per the plan view detail.
- Minimum concrete compressive strength is 2500 psi.
- When rebar is required it does not need to be tied to the SSTB.
- Order SSTBL Models (example: SSTB16L) for longer thread length (16L = 5½", 20L = 6½", 24L = 6", 28L = 6½"). SSTB and SSTBL load values are the same. SSTB34 and SSTB36 feature 4½" and 6½" of thread respectively and are not available in "L" versions.

CMU

- One horizontal #4 rebar in the second course.
- One vertical #4 rebar in adjacent cell for ½" diameter SSTB.
- One vertical #4 rebar in an adjacent cell and additional vertical #4 rebar(s) at 24" o.c. max. for ¾" diameter SSTBs (2 total vertical rebars for end wall corner, 3 total vertical rebars for midwall).

CODES: See page 12 for Code Reference Key Chart.

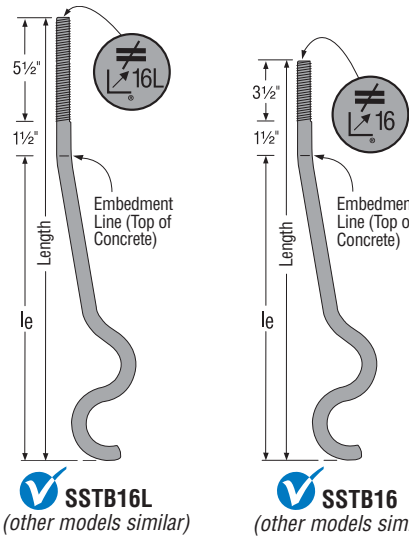

Identification on the bolt head showing embedment angle and model.

See pages 36-37 for additional installation details.

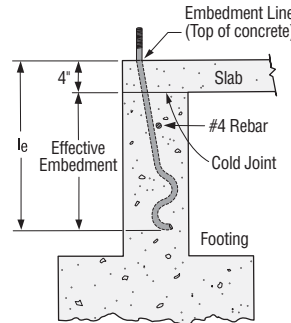

Two Pour Installation (SSTB20, 24, 34 and 36)

For two-pour (4" slab) installation loads:

- When using the SSTB20, use the equivalent loads of the SSTB16.
- When using the SSTB24, use the equivalent loads of the SSTB20.
- When using the SSTB34 or 36, use the equivalent loads of the SSTB28.

These products are available with additional corrosion protection. Additional products on this page may also be available with this option, check with Simpson Strong-Tie for details.

SSTB Bolts at Stemwall

Model No.	Dimensions				Allowable Tension Loads						Code Ref.
	Stemwall Width (in.)	Dia. (in.)	Length (in.)	Min. Embed. (le)	Wind & SDC A&B			SDC C - F			
					Midwall	Corner	End Wall ²	Midwall	Corner	End Wall ²	
SSTB16	6	5/8	17 5/8 (16L = 19 1/2)	12 5/8	3610	3610	3610	2550	2550	2550	I23, F30, L20
SSTB20	6	5/8	21 5/8 (20L = 24 5/8)	16 5/8	4315	4040	4040	3145	2960	2960	
SSTB24	6	5/8	25 5/8 (24L = 28 1/2)	20 5/8	5025	4470	4470	3740	3325	3325	
SSTB28	8	7/8	29 7/8 (28L = 32 1/2)	24 7/8	9900	8710	7615	8315	7315	6395	
SSTB34	8	7/8	34 7/8	28 7/8	9900	8710	7615	8315	7315	6395	
SSTB36	8	7/8	36 7/8	28 7/8	9900	8710	7615	8315	7315	6395	

1. See page 36 for notes to the Designer.
2. SSTB28, SSTB34 and SSTB36 with 3 7/8" end distance allowable loads are 6605 lbs. (Wind and SDC A&B) and 5550 lbs (SDC C-F).

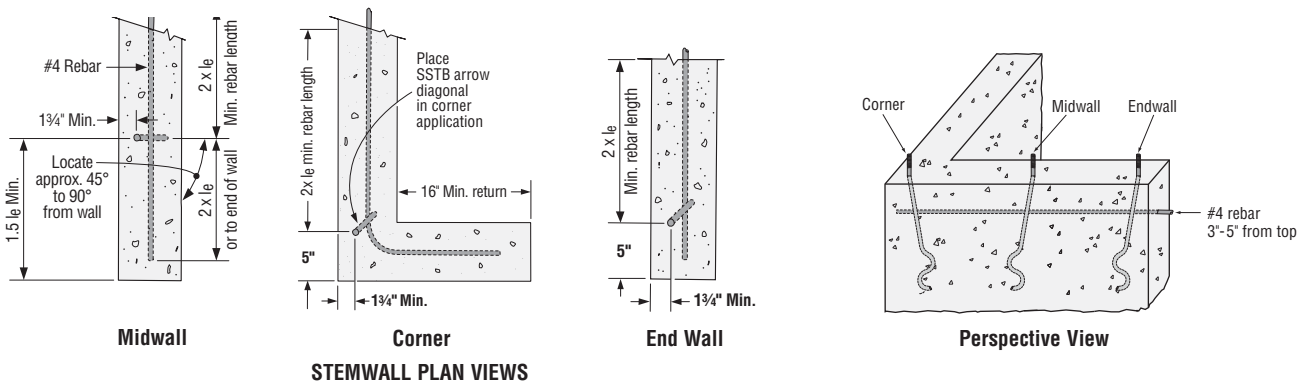

SSTB® Anchor Bolts

SSTB Bolts at Stemwall: Garage Front

Model No.	Dimensions (in.)				Allowable Tension Loads				Code Ref.
	Stemwall Width	Dia.	Length	Min. Embed. (l_e)	Wind & SDC A&B		SDC C-F		
					Step-Down End	Corner	Step-Down End	Corner	
SSTB28	8	7/8	29 7/8	24 7/8	7015	7045	5895	5920	I23

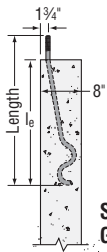

Stemwall Garage Front

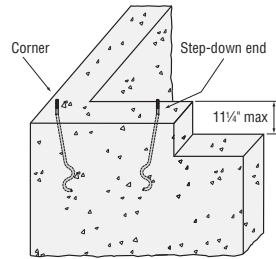

Perspective View

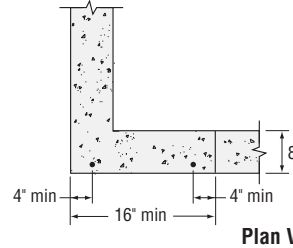

Plan View

SSTB Bolts at Slab on Grade: Edge

Model No.	Dimensions (in.)				Allowable Tension Loads				Code Ref.
	Footing Width	Dia.	Length	Min. Embed. (l_e)	Wind & SDC A&B		SDC C-F		
					Midwall	Corner	Midwall	Corner	
SSTB16	12	5/8	17 7/8	12 5/8	5355	5355	3780	3780	I23
SSTB20	12	5/8	25 7/8	16 7/8	6550	6550	4785	4785	
SSTB24	12	5/8	25 7/8	20 7/8	6675	6675	5790	5790	
SSTB28	12	7/8	29 7/8	24 7/8	13080	13080	11060	11645	
SSTB34	12	7/8	34 7/8	28 7/8	13080	13080	11060	11645	
SSTB36	12	7/8	36 7/8	28 7/8	13080	13080	11060	11645	

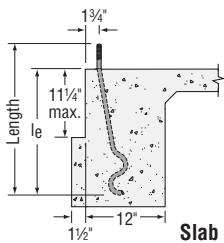

Slab Edge

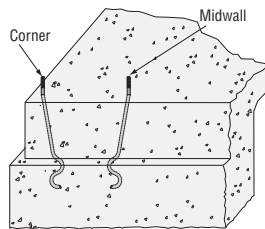

Perspective View

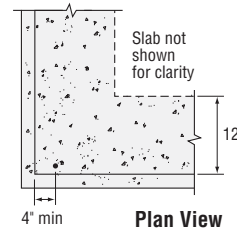

Plan View

SSTB Bolts at Slab on Grade: Garage Curb

Model No.	Dimensions (in.)				Allowable Tension Loads				Code Ref.
	Curb Width	Dia.	Length	Min. Embed. (l_e)	Wind & SDC A&B		SDC C-F		
					Step-Down End	Corner	Step-Down End	Corner	
SSTB28	6	7/8	29 7/8	24 7/8	10085	12375	8475	10395	I23

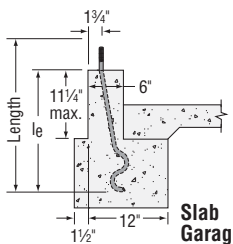

Slab Garage Curb

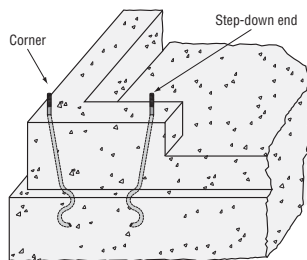

Perspective View

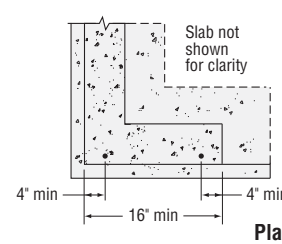

Plan View

Notes to the Designer:

- Rebar is required at top of stemwall foundations but is not required for Slab-on-Grade Edge and Garage Curb, or Stemwall Garage Front installations.
- Minimum end distances for SSTB bolts are as shown in graphics.
- Multiply the tabulated ASD wind or seismic loads by 1.6 or 1.4, respectively, to obtain LRFD capacities.
- Per Section 1613 of the IBC, detached one- and two-story dwellings in SDC C may use "Wind and SDC A&B" allowable loads.
- See ESR-2611 for additional information.
- Midwall loads apply when anchor is 1.5 l_e or greater from the end. For bolts acting in tension simultaneously, the minimum bolt center-to-center spacing is 3 l_e .

SSTB® Anchor Bolts

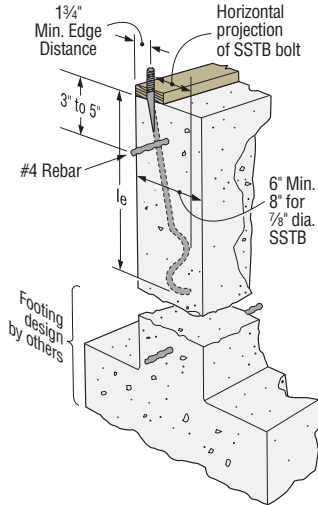

Typical SSTB Installation in Concrete Foundation
Maintain minimum rebar cover, per ACI-318 concrete code requirements

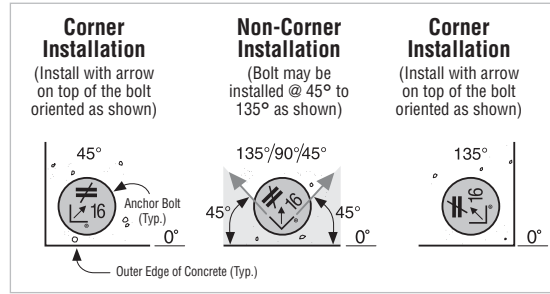

Plan View of SSTB Placement in Concrete

SSTB Bolts in 8" CMU

Model No.	Dia. (in.)	Length (in.)	Min. Embed. (le)	Allowable Tension Load		Code Ref.
				Midwall	Corner/End Wall	
SSTB16	5/8"	17 3/8" (16L = 19%)	12 3/8"	4780	1850	170
SSTB20	5/8"	21 3/8" (20L = 24%)	16 3/8"	4780	1850	
SSTB24	5/8"	25 3/8" (24L = 28%)	20 3/8"	4780	1850	
SSTB28	7/8"	29 3/8" (28L = 32%)	24 3/8"	6385	4815	
SSTB34	7/8"	34 3/8"	28 3/8"	6385	4815	
SSTB36	7/8"	36 3/8"	28 3/8"	6385	4815	

1. Loads are based on a minimum CMU compressive strength, f_m , of 1500 psi.
2. Minimum end distance required to achieve midwall table loads is 1.5 l_e .
3. Minimum end distance for corner/end wall loads is 4 1/4".
4. Loads may not be increased for duration of load.

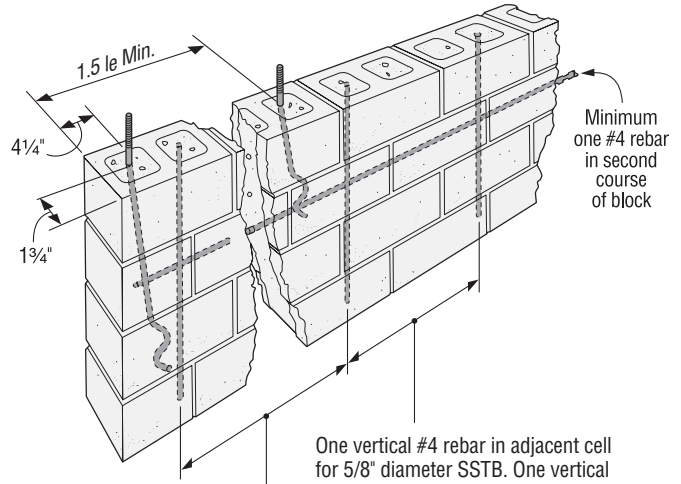

Typical SSTB Installation in Grouted Concrete Block

One vertical #4 rebar in adjacent cell for 5/8" diameter SSTB. One vertical #4 rebar and additional #4 rebar at 24" o.c. max. for 7/8" diameter SSTB. (2 total vertical rebars for endwall, 3 total vertical rebars for midwall)

GH Girder Hangers

A girder-to-foundation wall connection.

MATERIAL: 12 gauge

FINISH: Simpson Strong-Tie® gray paint, hot-dip galvanized, specify HDG.

See Corrosion Information, pages 13-15.

INSTALLATION: • Use all specified fasteners. See General Notes.

- Insert four 16d commons into girder.
- H = girder height – mudsill thickness. Measurement is top of steel to top of steel.
- 1 1/2" clearance hole accommodates rebar or anchor. This is not required.

OPTIONS: • GH hangers may be skewed to a maximum of 45° with no load reduction; bevel cut required.

- Specify GHD for saddle-style hangers. GHD may not be skewed.

CODES: See page 12 for Code Reference Key Chart.

Model No.	Girder	Dimensions (in.)					Fasteners	Allowable Loads		Code Ref.
		W	L	H 2x Plate	H 3x Plate	S		Floor (100)	Roof (125)	
GH46-6	4x6	3 3/16"	6	4	3	6 1/16"	4-16d	2000	2000	I20, F19
GH46-8	4x6	3 3/16"	6	4	3	8 1/16"	4-16d	2000	2000	
GH48-6	4x8	3 3/16"	6	5 3/4"	4 3/4"	6 1/16"	4-16d	2000	2000	
GH48-8	4x8	3 3/16"	6	5 3/4"	4 3/4"	8 1/16"	4-16d	2000	2000	
GH410-6	4x10	3 3/16"	6	7 3/4"	6 3/4"	6 1/16"	4-16d	2000	2000	170
GH410-8	4x10	3 3/16"	6	7 3/4"	6 3/4"	8 1/16"	4-16d	2000	2000	
GH66-6	6x6	5 1/2"	8	4	3	6 1/16"	4-16d	4000	4000	
GH66-8	6x6	5 1/2"	8	4	3	8 1/16"	4-16d	4000	4000	
GH68-6	6x8	5 1/2"	8	5 3/4"	4 3/4"	6 1/16"	4-16d	4000	4000	
GH68-8	6x8	5 1/2"	8	5 3/4"	4 3/4"	8 1/16"	4-16d	4000	4000	
GH610-6	6x10	5 1/2"	8	7 3/4"	6 3/4"	6 1/16"	4-16d	4000	4000	
GH610-8	6x10	5 1/2"	8	7 3/4"	6 3/4"	8 1/16"	4-16d	4000	4000	

1. Loads may not be increased for short-term loading.
2. A mudsill on top of the GH is required to achieve the table loads.
3. Models listed are for a 2x plate, specify "H" dimension when ordering for use with a 3x plate.
4. Uplift loads do not apply for this hanger.
5. **NAILS:** 16d = 0.162" dia. x 3 3/8" long. See pages 22-23 for other nail sizes and information.

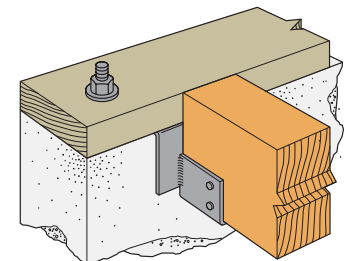
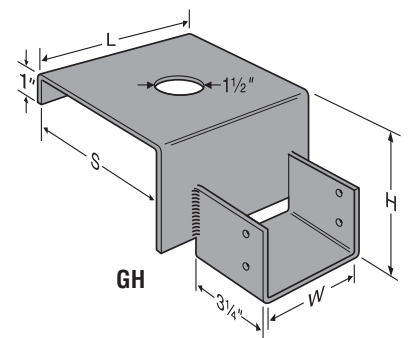

Typical GH Installation

PAB Pre-Assembled Anchor Bolt

The PAB anchor bolt is a versatile cast-in-place anchor bolt ideal for high-tension-load applications, such as rod systems and shearwalls. It features a plate washer at the embedded end sandwiched between two fixed hex nuts and a head stamp for easy identification after the pour.

- Available in diameters from 1/2" to 1 1/4" in lengths from 12" to 36" (in 6" increments)
- Available in standard and high-strength steel
- Head stamp contains the No Equal sign, diameter designation and an "H" on high-strength rods

MATERIAL: Standard Steel – ASTM F1554 Grade 36, A36 or A307 – $F_u = 58$ ksi
 High-Strength Steel (up to 1" dia.) – ASTM A449 – $F_u = 120$ ksi
 High-Strength Steel (1 1/8" and 1 1/4" dia.) – ASTM A193 B7 or F1554 Grade 105 – $F_u = 125$ ksi

FINISH: None

The Simpson Strong-Tie® Anchor Designer™ Software analyzes and suggests anchor solutions using the ACI 318 Appendix D strength-design methodology (or CAN/CSA A23.3 Annex D Limit States Design methodology). It provides cracked and uncracked-concrete anchorage solutions for numerous Simpson Strong-Tie mechanical and adhesive anchors as well as the PAB anchor bolt. With its easy-to-use graphical user interface, the software makes it easy for the Designer to identify anchorage solutions without having to perform time-consuming calculations by hand.

PAB Anchor Bolt – Standard Steel

Diameter (in.)	Plate Washer Size (in.)	l_1 (in.)	Root Model No.	Lengths (in.)
1/2	3/8 x 1 1/2 x 1 1/2	1 1/8	PAB4-XX	12" to 36" (in 6" increments)
5/8	1/2 x 1 3/4 x 1 3/4	1 3/8	PAB5-XX	
3/4	1/2 x 2 1/4 x 2 1/4	1 1/2	PAB6-XX	
7/8	1/2 x 2 1/2 x 2 1/2	1 5/8	PAB7-XX	
1	5/8 x 2 3/4 x 2 3/4	1 7/8	PAB8-XX	
1 1/8	5/8 x 3 1/4 x 3 1/4	2	PAB9-XX	
1 1/4	3/4 x 3 1/2 x 3 1/2	2 1/4	PAB10-XX	

How to specify and order:

When calling out PAB anchor bolts, substitute the desired length for the "XX" in the Root Model Number. For a 5/8"x18" anchor bolt, the model number would be PAB5-18 (or PAB5H-18 for high strength).

PAB Anchor Bolt – High-Strength Steel

Diameter (in.)	Plate Washer Size (in.)	l_1 (in.)	Root Model No.	Lengths (in.)
1/2	3/8 x 1 1/2 x 1 1/2	1 1/8	PAB4H-XX	12" to 36" (in 6" increments)
5/8	1/2 x 1 3/4 x 1 3/4	1 3/8	PAB5H-XX	
3/4	1/2 x 2 1/4 x 2 1/4	1 1/2	PAB6H-XX	
7/8	1/2 x 2 1/2 x 2 1/2	1 5/8	PAB7H-XX	
1	5/8 x 2 3/4 x 2 3/4	1 7/8	PAB8H-XX	
1 1/8	5/8 x 3 1/4 x 3 1/4	2	PAB9H-XX	
1 1/4	3/4 x 3 1/2 x 3 1/2	2 1/4	PAB10H-XX	

1. Lengths longer than 36" available as a special order.
2. Plate washers are designed to develop the capacity of the bolt.

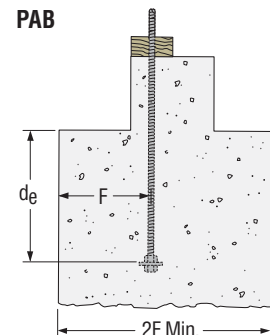
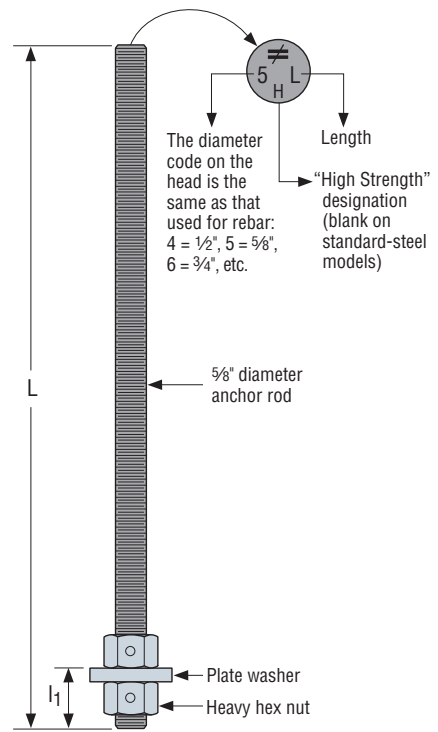

Design loads are calculated using a full shear cone. Coverage on each side of the bolt shall be a minimum of F or reductions must be taken.

PAB Anchor Bolt – Anchorage Solutions

Design Criteria	Diameter (in.)	Anchor Bolt	2500 psi Concrete				3000 psi Concrete			
			Dimensions (in.)		Tension Load		Dimensions (in.)		Tension Load	
			d_e (in.)	F (in.)	ASD	LRFD	d_e (in.)	F (in.)	ASD	LRFD
Wind	1/2	PAB4	4 1/2	7	4270	6405	4	6	4270	6405
	5/8	PAB5	4	6	4030	6720	4	6	4415	7360
	3/4	PAB6	6	9	6675	10010	5 1/2	8 1/2	6675	10010
			5 1/2	8 1/2	6500	10835	5	7 1/2	6175	10290
	7/8	PAB7	7 1/2	11 1/2	9610	14415	7	10 1/2	9610	14415
			6	9	7405	12345	5 1/2	8 1/2	7120	11870
	1	PAB8	9	13 1/2	13080	19620	8 1/2	13	13080	19620
			9	13 1/2	13610	22680	8 1/2	13	13680	22805
			14	21	27060	40590	13 1/2	20 1/2	27060	40590
	1 1/8	PAB8H	8	12	11405	19005	7 1/2	11 1/2	11340	18900
10 1/2			16	17080	25565	10	15	17080	25560	
10 1/2			16	17150	28580	10	15	17460	29100	
1 1/4	PAB9	16 1/2	25	35345	53015	15 1/2	23 1/2	35345	53015	
		9	13 1/2	13610	22680	8	12	12495	20820	
		12 1/2	19	21620	32430	12	18	21620	32430	
Seismic	1/2	PAB10	14	21	26690	40035	13 1/2	20 1/2	26690	40035
	5/8	PAB4	5	7 1/2	4270	6405	4 1/2	7	4270	6405
	3/4	PAB5	6 1/2	10	6675	10010	6	9	6675	10010
			7 1/2	11 1/2	9060	12940	7	10 1/2	8945	12780
	7/8	PAB6	8	12	9610	14415	7 1/2	11 1/2	9610	14415
			9	13 1/2	11905	17010	8 1/2	13	11970	17100
	1	PAB7	10	15	13080	19620	9 1/2	14 1/2	13080	19620
			14 1/2	22	25350	36215	13 1/2	20 1/2	24650	35215
			15 1/2	23 1/2	27060	40590	14 1/2	22	27060	40590
	1 1/8	PAB7H	11	16 1/2	15996	22850	10 1/2	16	16435	23480
			11 1/2	17 1/2	17080	25625	11	16 1/2	17080	25625
			17	25 1/2	33045	47205	16	24	32720	46740
	1 1/4	PAB8H	18	27	35345	53015	17	25 1/2	35345	53015
			12 1/2	19	19795	28275	12	18	20255	28940
			13 1/2	20 1/2	21620	32430	12 1/2	19	21620	32430
	1 1/4	PAB9	14 1/2	22	25350	36215	14	21	26190	37415
			15	22 1/2	26690	40035	14 1/2	22	26690	40035

Naming Legend: PAB5H-12



* Units in 1/8" Increments
(Ex: 9 = 9/8" or 1 1/8")

1. Anchorage designs conform to ACI 318-11 Appendix D and assume cracked concrete with no supplementary reinforcement.
2. Seismic indicates Seismic Design Category C through F. Detached one- and two-family dwellings in SDC C designs conform to ACI 318-11 Section D3.3.4.
3. Wind includes Seismic Design Category A and B.
4. Foundation dimensions are for anchorage only. Foundation design (size and reinforcement) by Designer. The registered design professional may specify alternate embedment, footing size, and anchor bolt.
5. Where tension loads are governed by anchor steel, the design provisions from AISC 360-10 are used to determine the tensile steel limit. LRFD values are calculated by multiplying the nominal AISC steel capacity by a 0.75 phi factor and allowable values are calculated by dividing the AISC nominal capacity by a 2.0 omega factor.
6. Where tension loads are governed by an Appendix D concrete limit, the allowable Stress Design (ASD) values are obtained by multiplying Load Factor Resistance Design (LRFD) capacities by 0.7 for Seismic and 0.6 for Wind.

RFB Retrofit Bolts

RFBs are clean, oil-free, pre-cut threaded rod, supplied with nut and washer. Offers a complete engineered anchoring system when used with Simpson Strong-Tie® adhesive. Inspection is easy; the head is stamped with rod length and “No Equal” symbol for identification after installation.

MATERIAL: ASTM F1554 Grade 36

FINISH: Zinc Plated (unless otherwise noted), available in HDG (per ASTM A153); stainless steel (RFB#5x8SS only).

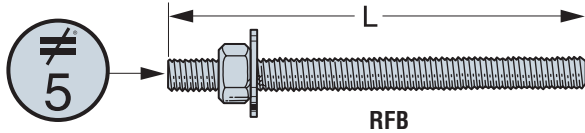

These products feature additional corrosion protection. Additional products on this page may also be available with this option, check with Simpson Strong-Tie for details.

Model No.	Length L (in)	Bolt Diameter
RFB#4X4	4	½
RFB#4X5	5	½
RFB#4X6	6	½
RFB#4X7	7	½
RFB#4X10	10	½
RFB#4x8HDG-R	8	½
RFB#5X5	5	¾
RFB#5X8	8	¾
RFB#5X10	10	¾
RFB#5X12HDG-R	12	¾
RFB#5X16	16	¾
RFB#6X10.5	10½	¾

- RFB#4X8HDG-R and RFB#5X12HDG-R are only available with a hot-dip galvanized coating. They are retail packaged and are sold 10 per carton.
- Washer provided on all RFB (except RFB#5x8SS).

CNW/HSCNW Coupler Nuts

Simpson Strong-Tie® coupler nuts are a tested and load-rated method to join threaded rod and anchor bolts. “Witness” holes in the nut provide a means to verify when rods are properly installed. The positive stop feature helps ensure even threading into each end of the nut. CNW’s meet and exceed the tensile capacity of corresponding ASTM A36 bolts and threaded rod. HSCNW’s meet and exceed the tensile capacity of corresponding ASTM A449 bolts and threaded rod. Contact Simpson Strong-Tie for other coupler nut sizes.

FINISH: Zinc Plated

INSTALLATION:

- Tighten the two rods until each all-thread rod is visible in the witness hole.
- For non-hot-dip galvanized all-thread rod only.
- ¾" and 7/8" diameter couplers available with oversized threads for installation to hot-dip galvanized bolts (order CNW^{5/8-5/8}Ost and CNW^{7/8-7/8}Ost).

CODES: See page 12 for Code Reference Key Chart.

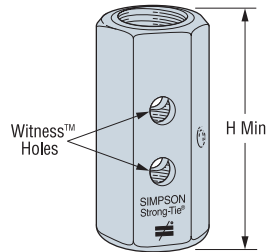

CNW
Allows fast visual check for correct all thread rod installation

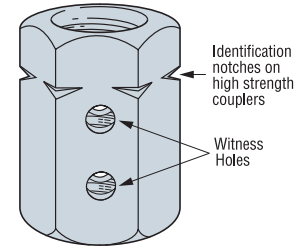

HSCNW
High Strength Coupler Nut

Model No.	Rod Diameter	H Min	Allowable Tension Capacity	Code Ref.
			(100)	
CNW½	0.500	1½	4265	I1, F34
CNW¾	0.625	1¾	6675	
CNW¾	0.750	2¼	9610	
CNW¾	0.875	2½	13080	170
CNW1	1.000	2¾	17080	
CNW1¼	1.250	3	26690	
HSCNW¾	0.750	2¼	19880	
HSCNW1	1.000	2¾	35345	
Transition Couplers				
CNW ^{5/8-1/2}	0.625 to 0.500	1½	4265	I1, F34
CNW ^{3/4-5/8}	0.750 to 0.625	1¾	6675	
CNW ^{7/8-5/8}	0.875 to 0.625	2	6675	170
CNW ^{1-7/8}	1.000 to 0.875	2¼	13080	

1. Allowable loads shown are based on AISC 13th Edition A36 and A449 (HS) threaded rod capacities.

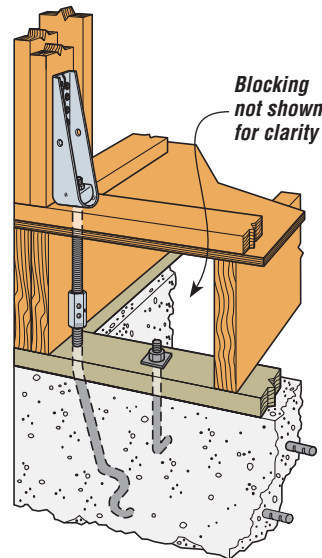

Typical CNW
Rim Joist Installation

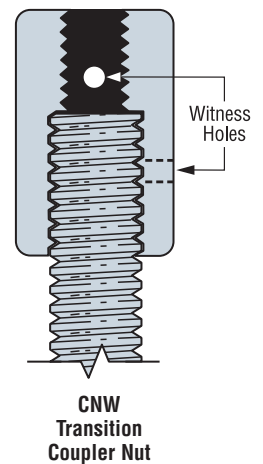

BP/LBP Bearing Plates

Bearing plates give greater bearing surface than standard cut washers, and help distribute the load at these critical connections.

The BP $\frac{1}{2}$ -3 and BP $\frac{5}{8}$ -3 are 3"x3" bearing plates that meet the latest requirements of the IRC and IBC. These plate washers are available uncoated or with a hot-dip galvanized (HDG) coating.

The BPS and LBPS are bearing plates that offer increased flexibility while meeting the latest requirements of the code for 2x4 and 2x6 walls. The slotted hole allows for adjustability to account for bolts that are not in the middle of the sill plate.

The BP $\frac{5}{8}$ SKT uses $\frac{1}{4}$ "x1 $\frac{1}{2}$ " Strong-Drive[®] SDS Heavy-Duty Connector screws to provide lateral resistance when $\frac{5}{8}$ " diameter sill holes are overdrilled (*screws are provided*). The shear capacity of the connection and the sill/anchor bolt shall be determined by the Designer for each installation.

MATERIAL: See table

FINISH: LBP, LBPS—Galvanized; BP $\frac{1}{2}$ -2, BP $\frac{5}{8}$ S—Zinc Plated; BPS, BP—None. BPs and BPSs may be ordered HDG; LBP and LBPS products may be ordered ZMAX[®]; contact Simpson Strong-Tie. See Corrosion Information, pages 13-15.

INSTALLATION: • See General Notes.

- BP/BPS—For shearwall applications, position edge of plate washer within $\frac{1}{2}$ " of sheathed edge of sill plate.

CODES: See page 12 for Code Reference Key Chart.

2012 IRC R602.11.1, 2008 SDPWS 4.3.6.4.3 (*see footnote 2 below*)

These products are available with additional corrosion protection. Additional products on this page may also be available with this option, check with Simpson Strong-Tie for details.

Bolt Dia. (in.)	Model No.	Thickness	Dimensions (in.)		Code Ref.
			W	L	
$\frac{1}{2}$	BP $\frac{1}{2}$ -2	$\frac{3}{16}$	2	2	180
	LBP $\frac{1}{2}$	$\frac{9}{64}$	2	2	
	LBPS $\frac{1}{2}$	$\frac{9}{64}$	3	3	
	BPS $\frac{1}{2}$ -3	3ga	3	3	
	BPS $\frac{1}{2}$ -6	3ga	3	4 $\frac{1}{2}$	
	BP $\frac{1}{2}$	$\frac{3}{16}$	2	2	
$\frac{5}{8}$	BP $\frac{1}{2}$ -3	3ga	3	3	I1, F34
	LBP $\frac{5}{8}$	$\frac{9}{64}$	2	2	180
	LBPS $\frac{5}{8}$	$\frac{9}{64}$	3	3	
	BPS $\frac{5}{8}$ -3	3ga	3	3	
	BPS $\frac{5}{8}$ -6	3ga	3	4 $\frac{1}{2}$	
	BP $\frac{5}{8}$ -2	$\frac{3}{16}$	2	2	
BP $\frac{5}{8}$ SKT	3ga	4	2	180	
$\frac{3}{4}$	BP $\frac{3}{4}$	$\frac{5}{16}$	2 $\frac{3}{4}$	2 $\frac{3}{4}$	I1, F34
	BP $\frac{3}{4}$ -3	3ga	3	3	
	BPS $\frac{3}{4}$ -3	3ga	3	3	
	BPS $\frac{3}{4}$ -6	3ga	3	4 $\frac{1}{2}$	
$\frac{7}{8}$	BP $\frac{7}{8}$ -2	$\frac{3}{8}$	1 $\frac{15}{16}$	2 $\frac{1}{4}$	180
	BP $\frac{7}{8}$	$\frac{5}{16}$	3	3	
1	BP1	$\frac{3}{8}$	3 $\frac{1}{2}$	3 $\frac{1}{2}$	

1. BP $\frac{5}{8}$ SKT sold as a kit.
2. Standard cut washer required with BPS $\frac{1}{2}$ -3, BPS $\frac{5}{8}$ -3, BPS $\frac{3}{4}$ -3, BPS $\frac{1}{2}$ -6, BPS $\frac{5}{8}$ -6 and BPS $\frac{3}{4}$ -6 (*not provided*) per the 2012 IRC and 2008 SDPWS.

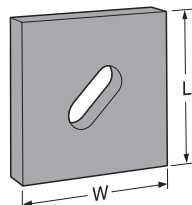

BPS
(LBPS similar)

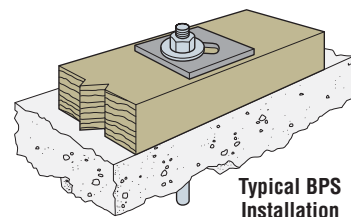

Typical BPS Installation

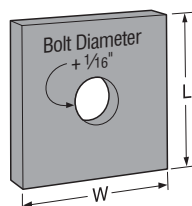

BP
(LBP similar)

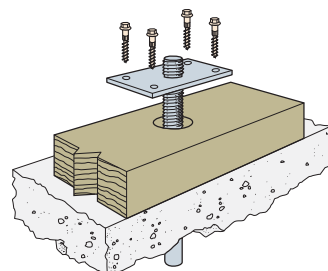

The BP $\frac{5}{8}$ SKT is used when $\frac{5}{8}$ " diameter sill bolt holes are overdrilled

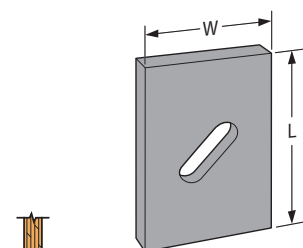

BPS $\frac{1}{2}$ -6
(Other models similar)

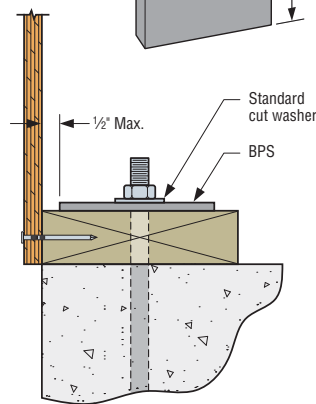

Typical BPS Installed as a Shear Anchor

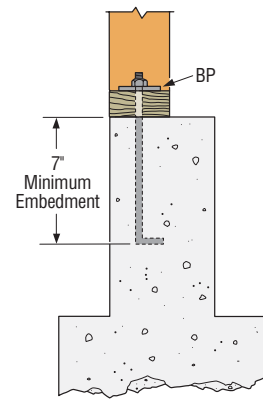

Typical BP Installed with a Mudsill Anchor Bolt

WT Wedge Form Ties

Designed for low foundation wall applications. $\frac{5}{8}$ " wide formed "V" design for rigidity allows accurate form spacing and support. Sizes now available for composite form board.

MATERIAL: Wedges—14 gauge, WT—18 gauge **FINISH:** Galvanized

INSTALLATION: • Use two 3 $\frac{1}{2}$ " long wedges for each tie.

- Not recommended for wall pours greater than 4' high.
- Wall thickness from 6" to 12".
- Refer to technical bulletin T-WT for recommended spacing.

Model No.	Form Board	Wall Thickness
WT6	2x Solid Sawn	6
WT8		8
WT10		10
WT12		12
WT6/125	1 $\frac{1}{4}$ " Composite	6
WT8/125		8

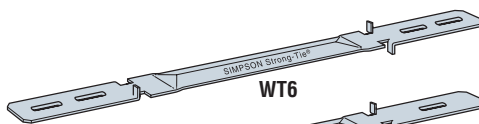

WT6

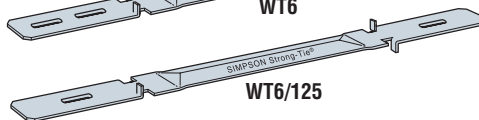

WT6/125



Order wedges separately. Specify W1.

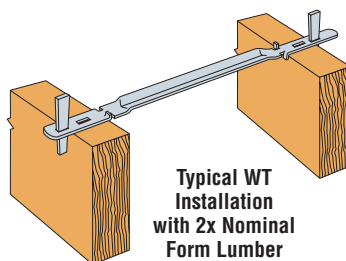

Typical WT Installation with 2x Nominal Form Lumber

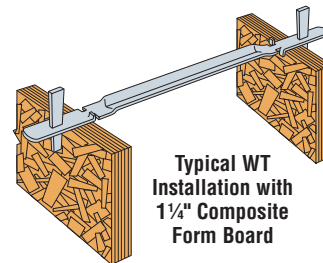

Typical WT Installation with 1 $\frac{1}{4}$ " Composite Form Board

ANCHORMATE® Anchor Bolt Holders

These reusable anchor bolt holders are designed to hold the anchor in place before the concrete pour, as required in some jurisdictions. The gripping section secures the bolt in place without a nut for quicker set up and tear down. It also protects the threads from wet concrete and simplifies trowel finishing.

- Built-in 2x4 and 2x6 stops eliminate measuring.
- Color-coded for easy size identification.
- Use the 5/8" and 7/8" AnchorMate to secure the SSTB to the formboard before the concrete pour. Alignment arrows (*left or right*) match the SSTB bolt head arrow.

MATERIAL: Nylon

CODES: See page 12 for Code Reference Key Chart.

Model No.	Dia.	Color	Code Ref.
AM½	½"	Yellow	180
AM5/8	5/8"	Blue	
AM¾	¾"	Red	
AM7/8	7/8"	Green	
AM1	1"	Black	

AnchorMate®
Anchor Bolt
Holder

U.S. Patent
6,065,730

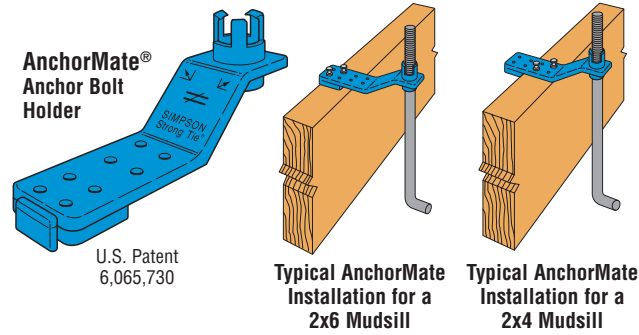

Typical AnchorMate
Installation for a
2x6 Mudsill

Typical AnchorMate
Installation for a
2x4 Mudsill

ABS Anchor Bolt Stabilizer

The ABS stabilizes the anchor bolt to prevent it from being pushed against the form during the concrete pour.

FEATURES:

- Supports the bolt approximately 8" below the top of the concrete.
- Model ABS5/8 is for the 5/8" SSTB and ABS7/8 is for the 7/8" SSTB.
- Thin section limits the effect of a cold joint.
- Sized for 2x4 and 2x6 mudsills.

MATERIAL: Engineered Composite Plastic.

CODES: See page 12 for Code Reference Key Chart.

Model No.	Dia.	Color	Code Ref.
ABS5/8	5/8"	Blue	180
ABS7/8	7/8"	Green	

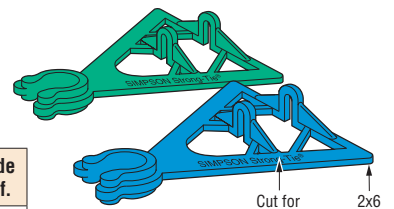

ABS Anchor Bolt Stabilizer

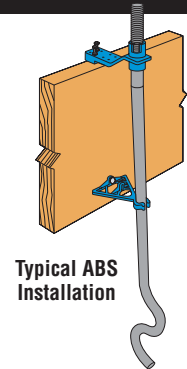

Typical ABS
Installation

STRAPMATE® Strap Holder

The StrapMate is designed to keep the STHD and LSTHD straps vertically aligned during the concrete pour to minimize possibility of spalling. The friction fit allows for quick and easy installation.

- The StrapMate is reusable.
- Works with STHD, LSTHD.

MATERIAL: Engineered Composite Plastic.

- Designed to fit ¾" plywood forms up to 1¾" LVL forms and larger.
- The strap is positioned off the front edge of the form board.

CODES: See page 12 for Code Reference Key Chart.

Model No.	Nails	Code Ref.
SM1	2-8d Duplex	180

StrapMate
Strap Holder

U.S. Patent
6,796,099

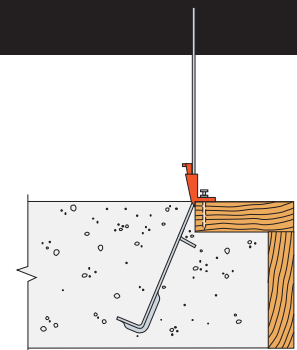
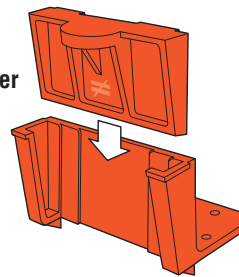

Alternate StrapMate Installation
for Brick Ledges

ABL Anchor Bolt Locator

The ABL enables the accurate and secure placement of anchor bolts on concrete-deck forms prior to concrete placement. The structural heavy-hex nut is attached to a pre-formed steel "chair", which eliminates the need for an additional nut on the bottom of the anchor bolt. Electro-galvanized versions available for HDG anchor bolts. Order ABL-OST when using HDG anchor bolts.

FEATURES:

- Designed for optimum concrete flow
- Installed with nails or screws
- Meets code requirement for 1" stand off.
Also available with 1½" standoff.
Order ABLXX-1.5.
- PAB anchors are not designed for use with the ABL. Contact Simpson Strong-Tie for pre-assembled anchor solutions to be used with ABL.

MATERIAL: Nut - Heavy hex, Chair - Steel
FINISH: Nut - None or Electro-galvanized;
Chair - G90; **ABL-OST - HDG**

CODES: See page 12 for Code Reference Key Chart.

Model No.	Anchor Bolt Dia.	Code Ref.
ABL4-1	½"	180
ABL5-1	5/8"	
ABL6-1	¾"	
ABL7-1	7/8"	
ABL8-1	1"	
ABL9-1	1½"	
ABL10-1	1¾"	

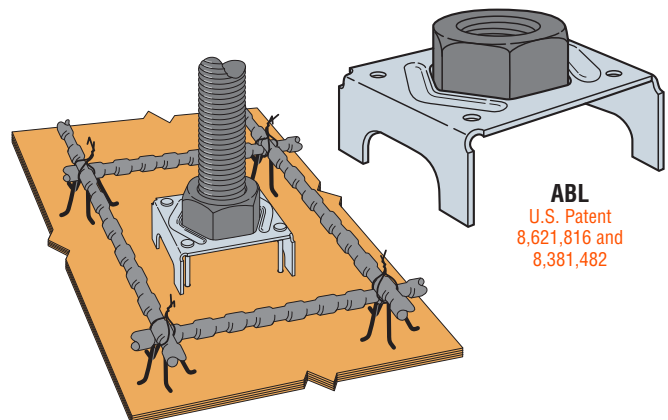

Typical ABL Installation

ABL
U.S. Patent
8,621,816 and
8,381,482

ANCHORING SYSTEMS *Sill Plate Anchorage and Fastening Solutions*

Simpson Strong-Tie offers many fastening and post-installed anchorage solutions for sill plate applications in concrete or concrete block foundations. These products are often used in retrofit/expansion applications or when cast-in-place anchors are omitted or mis-located. Various product finishes are available to address most environmental or preservative-treated wood conditions. For more information on product performance, installation requirements, corrosion and appropriate code listings for Simpson Strong-Tie® products, please visit www.strongtie.com.

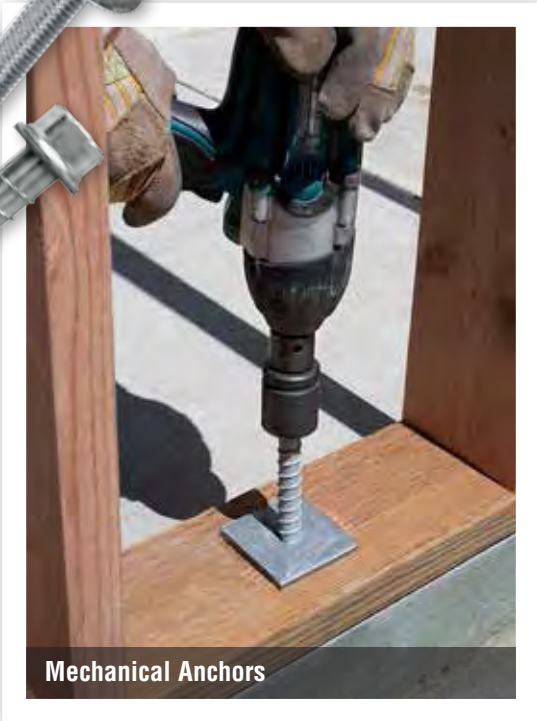

Mechanical Anchors



Anchoring Adhesives



Direct Fastening Systems

Software Tools to Help You Select the Right Products



Anchor Designer™
ACI 318



Adhesive Cartridge Estimator

For more information, visit www.strongtie.com/software.



ANCHORING SYSTEMS For Cracked-Concrete Applications**SET-XP® High-Strength Anchoring Adhesive**

A two-part, high-strength epoxy anchoring adhesive system formulated for threaded rod and rebar anchoring into concrete (*cracked/uncracked*) and masonry, SET-XP is a teal color when mixed, providing easy post-installation identification.

FEATURES:

- Qualified under ICC-ES AC308 regarding elevated temperature and long-term sustained loading conditions
- Code-listed under the IBC/IRC for cracked and uncracked concrete per ICC-ES ESR-2508
- Code-listed under the IBC/IRC for masonry per IAPMO UES ER-265
- Suitable for use under static and seismic loading conditions in cracked and uncracked concrete
- Multiple DOT listings; refer to www.strongtie.com/DOT
- Manufactured in the USA using global materials

CODES: ICC-ES ESR-2508 (concrete); IAPMO UES ER-265 (masonry); City of L.A. RR25744 (concrete); City of L.A. RR25965 (masonry); Florida FL15730 (concrete), FL16230 (masonry); ASTM C 881 (Type I and IV, Grade 3, Class C); NSF/ANSI Standard 61 (216 in²/1000 gal)

AT-XP® High-Strength, Fast-Cure, All-Weather Anchoring Adhesive

Formulated for high-strength anchorage of threaded rod and rebar into concrete (*cracked/uncracked*) and masonry under a wide range of conditions, AT-XP dispenses easily in cold or warm environments and, when mixed, is a dark teal color for easy post-installation identification.

FEATURES:

- Qualified under ICC-ES AC308 regarding reduced temperature, elevated temperature, and long-term sustained loading conditions
- Code-listed under the IBC/IRC for cracked and uncracked concrete per IAPMO UES ER-263
- Code-listed under the IBC/IRC for masonry per IAPMO UES ER-281
- Fully cures in temperatures as low as 14°F (-10°C)
- Suitable for use under static and seismic loading conditions in cracked and uncracked concrete
- Manufactured in the USA using global materials

CODES: IAPMO UES ER-263 (concrete), ER-281 (masonry); City of L.A. RR25960 (concrete), RR25966 (masonry); Florida FL 16230, NSF/ANSI Standard 61 (43.2 in²/1000 gal)

ET-HP® Anchoring Adhesive

A two-part epoxy anchoring adhesive system formulated for threaded rod and rebar anchoring into concrete (*cracked/uncracked*) and masonry.

FEATURES:

- Qualified under ICC-ES AC308 regarding elevated temperature and long-term sustained loading conditions
- Code-listed under the IBC/IRC for cracked and uncracked concrete per ICC-ES ESR-3372
- Code-listed under the IBC/IRC for uncracked masonry per IAPMO UES ER-241
- Suitable for use under static and seismic loading conditions in cracked and uncracked concrete
- Multiple DOT listings; refer to www.strongtie.com/DOT
- Manufactured in the USA using global materials

CODES: ICC-ES ESR-3372 (concrete); ICC-ES ESR-3638 (unreinforced masonry); IAPMO UES ER-241 (masonry); City of L.A. RR25120 (unreinforced masonry); ASTM C 881 (Type I, II, IV and V, Grade 3, Class B and C, except gel time)

STRONG-BOLT® 2 Wedge Anchor

A wedge-type expansion anchor designed for optimum performance in cracked and uncracked concrete and uncracked masonry, the Strong-Bolt 2 is available in carbon-steel (¼" through 1" diameter) and Type 316 stainless steel (¼" through ¾" diameter).

FEATURES:

- Code-listed under IBC/IRC for cracked and uncracked concrete per ICC-ES ESR-3037
- Code-listed under IBC/IRC for masonry per IAPMO UES ER-240
- Qualified for static and seismic loading conditions

CODES: ICC-ES ESR-3037 (concrete); IAPMO UES ER-240 (carbon steel in CMU); City of L.A. RR25891 (concrete), RR25936 (carbon steel in CMU); Florida FL 15731; UL File Ex3605; FM 3043342 and 3047639; meets the requirements of Federal Specifications A-A-1923A, Type 4

TORQ-CUT™ Self-Undercutting Anchor

A heavy-duty, high-capacity, self-undercutting anchor designed for cracked and uncracked concrete applications, the Torq-Cut has a built-in cutting ring that provides superior load-carrying capacity.

FEATURES:

- Code-listed under IBC/IRC for cracked and uncracked concrete per ICC-ES ESR-2705
- Provides higher load-carrying capacity than conventional mechanical anchors
- Excellent for resisting seismic (SDC A-F) and vibratory loads
- No special installation tools required

CODES: ICC-ES ESR-2705 (concrete); City of L.A. RR25946 (concrete); Florida FL15731

U.S. Patent 7,357,613

For complete information on these products, visit www.strongtie.com.

ANCHORING SYSTEMS For Cracked-Concrete Applications**TITEN HD® Concrete Screw**

U.S. Patent
5,674,035 & 6,623,228

The original, patented, high-strength screw anchor that offers industry-leading performance in cracked and uncracked concrete and **uncracked** masonry, the Titen HD installs with low installation torque for maximum efficiency.

FEATURES:

- Code-listed under IBC/IRC in accordance with ICC-ES AC193 for cracked and uncracked concrete per ICC-ES ESR-2713; includes Titen HD® Rod Hanger (models THD37212RH and THD50234RH only)
- Code-listed under IBC/IRC in accordance with ICC-ES AC106 for masonry per ICC-ES ESR-1056
- Qualified for static and seismic loading conditions
- Standard fractional sizes; no special drill bits required
- Removable; ideal for temporary anchoring applications like formwork or bracing

CODES: ICC-ES ESR-2713 (concrete), ICC-ES ESR-1056 (masonry); City of L.A. RR25741 (concrete), RR25560 (masonry); Florida FL 15730; FM 3017082, 3035761 and 3043442

ANCHORING SYSTEMS For General-Purpose Applications**SET® Anchoring Adhesive**

A non-shrink, epoxy based anchoring system, SET is formulated for anchoring threaded rod and rebar in a wide range of base materials.

FEATURES:

- Code-listed under the IBC/IRC for URM per ICC-ES ESR-1772
- Excellent as a pick-proof sealant around doors, windows and fixtures
- CalTrans and multiple DOT listings; refer to www.strongtie.com/DOT
- Manufactured in the USA [using global materials](#)

CODES: ICC-ES ESR-1772 (URM); City of L.A. RR25279 (**masonry**); Florida FL 15730; ASTM C 881 (Type I, II and IV, Grade 3, Class B and C); NSF/ANSI Standard 61 (216 in²/1000 gal) – except SET 1.7KTA

AT Fast-Cure, All-Weather Anchoring Adhesive

An acrylic-based adhesive anchoring system, AT is formulated for use as a high-strength **anchoring** material for threaded rod and rebar in a wide range of temperatures and base materials.

FEATURES:

- Code-listed under the IBC/IRC for URM per ICC-ES ESR-1958
- Fully cures in temperatures as low as 0°F (-18°C)
- Multiple DOT listings; refer to www.strongtie.com/DOT
- Manufactured in the USA [using global materials](#)

CODES: ICC-ES ESR-1958 (URM); Florida FL 14832; ASTM C 881 (Type I and IV, Grade 3, Class A, B and C – except AT is a non-epoxy formulated for fast cure time); NSF/ANSI Standard 61 (2.2 in²/1000 gal)

WEDGE-ALL® Wedge Anchor

A non-bottom bearing, wedge-style expansion anchor for use in solid concrete or grout-filled masonry, the Wedge-All is available in carbon steel, mechanically galvanized, and Types 303/304/316 stainless steel.

FEATURES:

- Code-listed under the IBC/IRC for CMU per ICC-ES ESR-1396
- One-piece, wrap-around clip ensures uniform holding capacity
- Chamfered thread end for ease of starting nut
- Wide range of diameters and lengths for added versatility

CODES: ICC-ES-ESR-1396 (CMU); City of L.A. RR24682 (**CMU**); Florida FL 15730; FM 3017082 and 3131136; UL File Ex3605; meets the requirements of Federal Specifications A-A-1923A, **Type 4**.

Note: The Tie-Wire Anchor is not code-listed.

GENERAL INFORMATION AND NOTES

Holdowns and tension ties represent key components that comprise a continuous load path. In light-frame construction, holdowns are typically used to resist uplift due to shearwall overturning or wind uplift forces. In panelized roof construction, holdowns are used to anchor the concrete or masonry walls to the roof framing.

Holdowns can be separated into two categories – post-installed or cast-in-place. Cast-in-place holdowns, such as the STHD holdowns or the PA purlin anchors are installed at the time of concrete placement and attached to wood framing with nails. Cast-in-place holdowns are an economical anchorage solution with capacities up to 5,300 lbs.

After the concrete has been placed, post-installed holdowns are attached to anchor bolts during wall framing. They are attached to the wood framing with nails, Simpson Strong-Tie® Strong-Drive® SDS Heavy-Duty Connector screws or bolts and have capacities ranging from about 2000 lbs. up to nearly 20,000 lbs.

Holdown and Tension Tie General Notes:

- Allowable loads have been increased for earthquake or wind load durations with no further increase allowed. Reduce where other loads govern.
- **Multiply Seismic and Wind ASD load values by 1.4 and 1.6, respectively, to obtain LRFD load capacities.**
- Use all specified fasteners.
- The Designer must specify anchor bolt type, length and embedment. See pages 33-37 for SB and SSTB anchor bolts and page 38 for PAB anchor bolts.
- Anchor bolt nut should be finger tight plus $\frac{1}{3}$ to $\frac{1}{2}$ turn with a hand wrench, with consideration given to possible future wood shrinkage. Care should be taken not to over-tighten the nut. Impact wrenches should not be used.
- Post or beam design by Specifier. Tabulated loads are based on a minimum $3\frac{1}{2}$ " wide post (in a $3\frac{1}{2}$ " wall), unless noted otherwise. Posts may consist of multiple members provided they are connected independently of the holddown fasteners. See pages 245-246 for common post allowable loads.
- Holdowns are for use in vertical or horizontal applications.
- Tension values are valid for holdowns installed flush or raised off the sill plate.
- Deflection at Allowable Tension Load is determined by testing on wood posts and includes fastener slip, holdown deformation and anchor rod elongation for holdowns installed 6" above top of concrete ($4\frac{1}{2}$ " for HTT).
- Holdowns may be installed raised up to 18" above the top of concrete with no load reduction provided that additional elongation of the anchor rod is accounted for.
- Tabulated loads for bolted holdowns may be doubled when holdowns are installed on opposite sides of the wood member. Designer must evaluate the capacity of the wood member and the anchorage.
- Tabulated loads for nailed or screwed holdowns may be doubled when holdowns are installed on opposite sides of the wood member. Member must be thick enough to prevent opposing holddown fastener interference or the holdowns are offset to eliminate fastener interference. Designer must evaluate the capacity of the wood member and the anchorage. See pages 245-246 for common post allowable loads.
- Structural composite lumber columns have sides that either show the wide face or the edges of the lumber strands/veneers known as the narrow face. Values in the tables reflect installation into the wide face. See Technical Bulletin T-C-SCLCLM for load reductions due to narrow face installations.

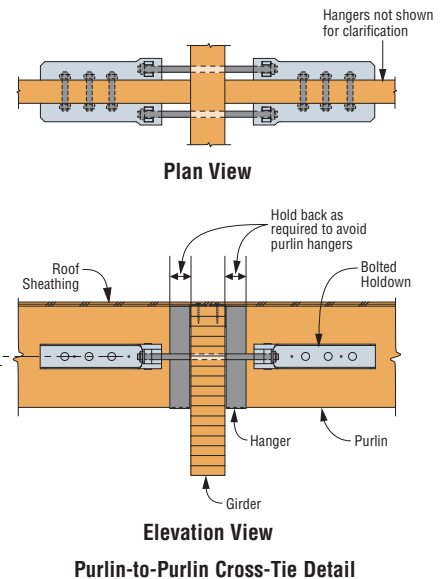
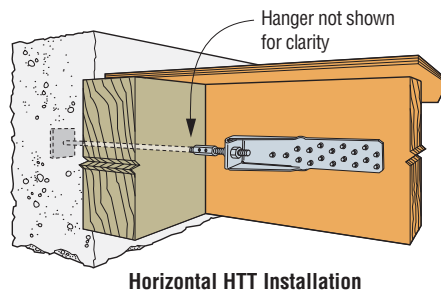
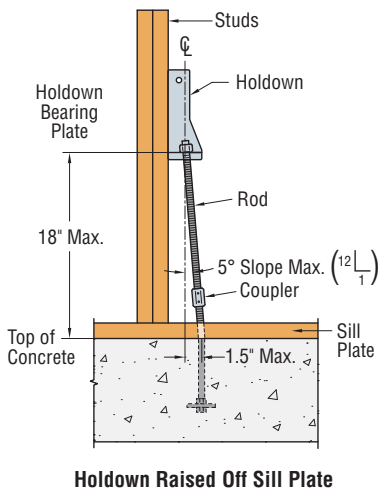
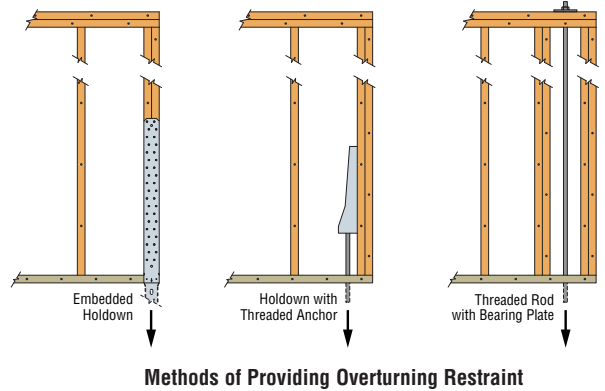
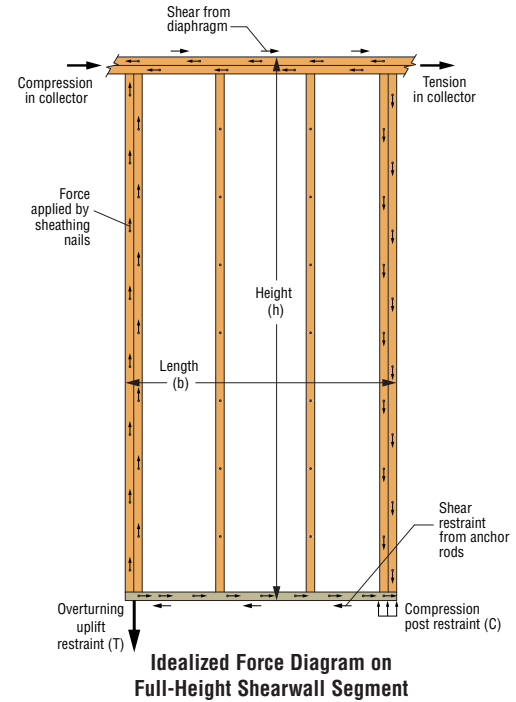

C-C-2015 © 2015 SIMPSON STRONG-TIE COMPANY INC. PRINTED 12/14 (This page has been updated since printing)

Holdowns & Tension Ties

HDU/DTT Holdowns



This product is preferable to similar connectors because of a) easier installation, b) higher loads, c) lower installed cost, or a combination of these features.

HDU holdowns are pre-deflected during the manufacturing process, virtually eliminating deflection under load due to material stretch. They use Simpson Strong-Tie® Strong-Drive® SDS Heavy-Duty Connector screws which install easily, reduce fastener slip and provide a greater net section when compared to bolts.

The HDU series of holdowns are designed to replace previous versions of the product such as PHDs as well as bolted holdowns. The HDU2, 4 and 5 are direct replacements for the PHD2, 5 and 6, respectively.

The DTT tension ties are designed for lighter-duty holdown applications on single 2x posts. The new DTT1Z is installed with nails or Simpson Strong-Tie Strong-Drive SD Connector screws and the DTT2Z installs easily with the Strong-Drive SDS Heavy-Duty Connector screws (included). The DTT1Z holdowns have been tested for use in designed shearwalls and prescriptive braced wall panels as well as prescriptive wood-deck applications (see page 209 for deck applications).

For more information on holddown options, contact Simpson Strong-Tie.

HDU SPECIAL FEATURES:

- Holdown designs virtually eliminate deflection due to material stretch.
- Uses Strong-Drive SDS Heavy-Duty Connector screws which install easily, reduce fastener slip, and provide a greater net section area of the post compared to bolts.
- Strong-Drive SDS Heavy-Duty Connector screws are supplied with the holdowns to ensure proper fasteners are used.
- No stud bolts to countersink at openings.

MATERIAL: See table

FINISH: HDU – Galvanized; DTT1Z and DTT2Z – ZMAX® coating; DTT2SS – stainless steel

INSTALLATION: • See General Notes on page 45.

- The HDU requires no additional washer, the DTT requires a standard cut washer (included with DTT2Z) be installed between the nut and the seat.
- Strong-Drive SDS Heavy-Duty Connector screws install best with a low speed high torque drill with a 3/8" hex head driver.

CODES: See page 12 for Code Reference Key Chart.

These products are available with additional corrosion protection. Additional products on this page may also be available with this option, check with Simpson Strong-Tie for details.

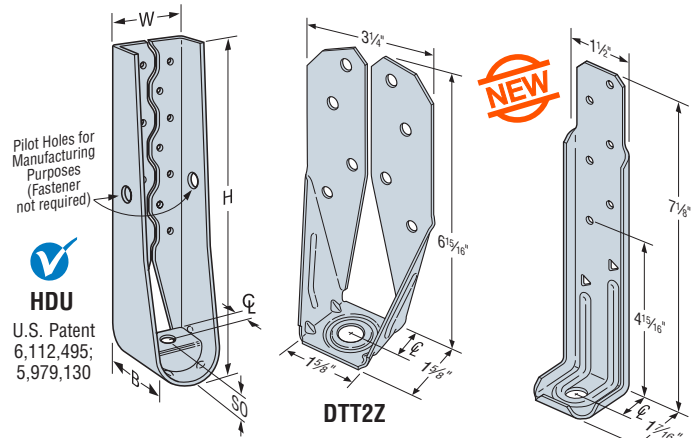

HDU
U.S. Patent
6,112,495;
5,979,130

DTT2Z



DTT1Z
U.S. Patent
Pending

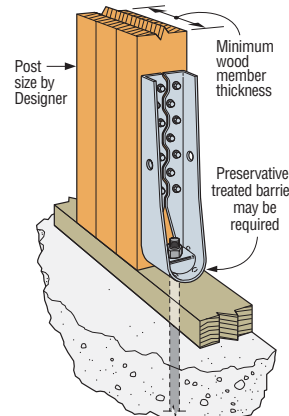

Vertical HDU Installation

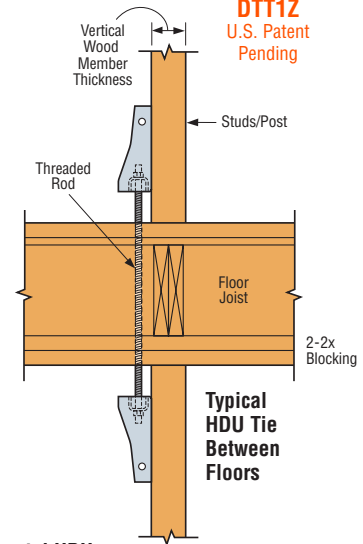

Typical HDU Tie Between Floors

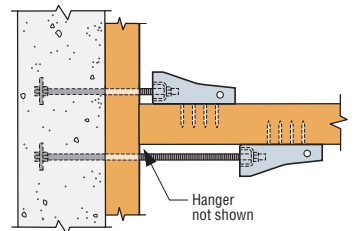

Horizontal HDU Offset Installation (Plan View)

See Holdown and Tension Tie General Notes on page 45.

Model No.	Ga	Dimensions (in.)					Fasteners		Minimum Wood Member Thickness (in.)	Allowable Tension Loads (160) ¹			Code Ref.	
		W	H	B	¢	SO	Anchor Bolt Dia. (in.)	Post Fasteners		DF/SP	SPF/HF	Deflection at Allowable Load (in.)		
DTT1Z	14	1 1/2	7 1/8	1 1/16	3/4	3/16	3/8	6-SD #9x1 1/2	1 1/2	840	840	0.170	160	
								6-10dx1 1/2		910	640	0.167		
								8-10dx1 1/2		910	850	0.167		
DTT2Z	14	3 3/4	6 15/16	1 5/8	1 3/16	3/16	1/2	8-SDS 1/4"x1 1/2"	1 1/2	1825	1800	0.105	16, L8, F5	
								8-SDS 1/4"x1 1/2"		3	2145	1835		0.128
								8-SDS 1/4"x2 1/2"		3	2145	2105		0.128
HDU2-SDS2.5	14	3	8 1/16	3 3/4	1 1/16	1 1/8	3/8	6-SDS 1/4"x2 1/2"	3	3075	2215	0.088	16, L8, F5	
HDU4-SDS2.5	14	3	10 5/16	3 3/4	1 1/16	1 1/8	3/8	10-SDS 1/4"x2 1/2"	3	4565	3285	0.114		
HDU5-SDS2.5	14	3	13 3/16	3 3/4	1 1/16	1 1/8	5/8	14-SDS 1/4"x2 1/2"	3	5645	4065	0.115		
HDU8-SDS2.5	10	3	16 5/8	3 1/2	1 1/8	1 1/2	7/8	20-SDS 1/4"x2 1/2"	3	6765	4870	0.084		
									3 1/2	6970	5020	0.116		
HDU11-SDS2.5	10	3	22 1/4	3 1/2	1 1/8	1 1/2	1	30-SDS 1/4"x2 1/2"	4 1/2	7870	5665	0.113		
									5 1/2	9535	6865	0.137		
HDU14-SDS2.5	7	3	25 11/16	3 1/2	1 1/16	1 1/16	1	36-SDS 1/4"x2 1/2"	7 1/4	11175	8045	0.137	170	
									4x6 ^{3,4}	10770	7755	0.122		
									7 1/4 ³	14390	10435	0.177		
								5 1/2 ^{2,3}	14445	10350	0.177	F5		

1. See page 45 for Holdown and Tension Tie General Notes.
 2. Noted HDU14 allowable loads are based on a 5 1/2" wide post (6x6 min.).
 3. HDU14 requires heavy hex anchor nut to achieve tabulated loads (supplied with holdown).
 4. Loads are applicable to installation on either narrow or wide face of post.

HDQ8/HHDQ Holdowns

The HHDQ series of holdowns combines low deflection and high loads with ease of installation. The unique seat design of the HDQ8 greatly minimizes deflection under load. Both styles of holddown employ the Simpson Strong-Tie® Strong-Drive® SDS Heavy-Duty Connector screws which install easily, reduce fastener slip and provide a greater net section when compared to bolts. They may be installed either flush or raised off the mudsill without a reduction in load value.

SPECIAL FEATURES:

- Uses Strong-Drive SDS Heavy-Duty Connector screws which install easily, reduce fastener slip, and provide a greater net section area of the post compared to bolts.
- Strong-Drive SDS Heavy-Duty Connector screws are supplied with the holdowns to ensure proper fasteners are used.
- No stud bolts to countersink at openings.

MATERIAL: HDQ8—7 gauge; HHDQ—Body: 7 gauge, washer: ½" plate

FINISH: HDQ8—Galvanized; HHDQ—Simpson Strong-Tie® gray paint

INSTALLATION: • See General Notes on page 45.

- No additional washer is required.
- Strong-Drive SDS Heavy-Duty Connector screws install best with a low speed high torque drill with a ⅜" hex head driver.

HDQ8:

- ⅜" of adjustability perpendicular to the wall.

HHDQ11/14:

- No additional washer is required.
- HHDQ14 requires a heavy hex anchor nut (supplied with holddown)

CODES: See page 12 for Code Reference Key Chart.

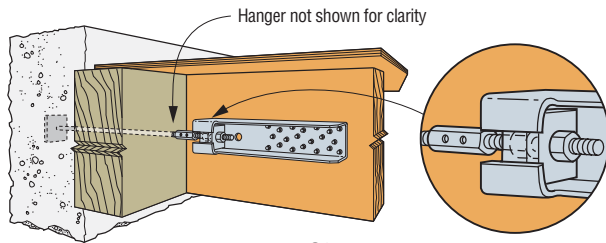

Horizontal HDQ8 Installation

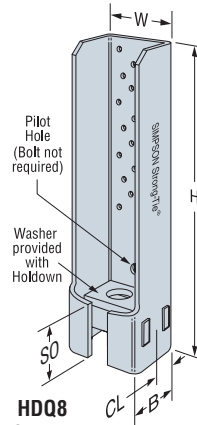

HDQ8
U.S. Patents
6,006,487 and
6,327,831

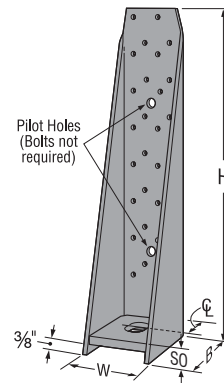

HHDQ11
(HHDQ14 similar)

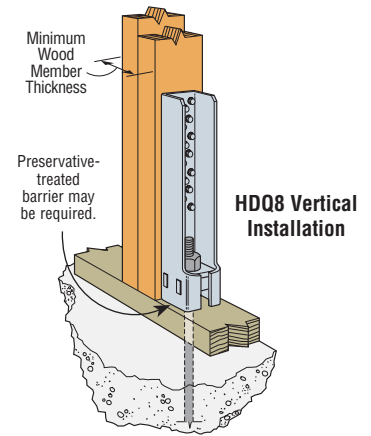

HDQ8 Vertical Installation

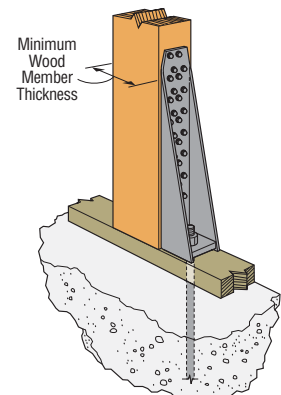

Vertical HHDQ11 Installation
(HHDQ14 similar)

Not sure you have the right holddown?

Our Holddown Selector software is a great tool to help you select the best product for the job. Visit www.strongtie.com/software.

These products are available with additional corrosion protection. Additional products on this page may also be available with this option, check with Simpson Strong-Tie for details.

Model No.	Ga	Dimensions (in.)					Fasteners		Minimum Wood Member Thickness ⁴ (in.)	Allowable Tension Loads (160)			Code Ref.
		W	H	B	CL	SO	Anchor Bolt Dia. (in.)	SDS Screws		DF/SP	SPF/HF	Deflection at Allowable Load ⁶ (in.)	
HDQ8-SDS3	7	2⅞	14	2½	1¼	2⅝	⅞	20-SDS ¼"x3"	3	5715	4115	0.064	16, L8, F5
								20-SDS ¼"x3"	3½	7630	5495	0.094	
								20-SDS ¼"x3"	4½	9230	6645	0.095	
HHDQ11-SDS2.5	7	3	15⅞	3½	1½	⅞	1	24-SDS ¼"x2½"	5½	11810	8505	0.131	
HHDQ14-SDS2.5	7	3	18¾	3½	1½	⅞	1	30-SDS ¼"x2½"	7¼	13015	9370	0.107	
									5½ ²	13710	10745	0.107	

1. See page 45 for Holdown and Tension Tie General Notes.
 2. Noted HHDQ14 allowable loads are based on a 5½" wide post (6x6 min.) Other loads based on 3½" wide post minimum.
 3. HHDQ14 requires heavy-hex anchor nut (supplied with holddown).
 4. HDQ and HHDQ installed horizontally achieve compression loads with the addition of a standard nut on the underside of the load transfer plate. Refer to ICC-ES ESR 2320 for design values. HDQ8 requires a standard nut and BP½-2 (sold separately) load washer on the underside of the holddown for compression load. Design of anchorage rods for compression force shall be per the Designer.

HDC Concentric Holdown



This product is preferable to similar connectors because of a) easier installation, b) higher loads, c) lower installed cost, or a combination of these features.

The unique design of the HDC holdowns eliminate eccentricity. They install with Simpson Strong-Tie® Strong-Drive® SDS Heavy-Duty Connector screws (included) to reduce slip and provide a greater net section area of the post compared to bolts.

MATERIAL: 10 gauge strap **FINISH:** Galvanized strap, aluminum base

INSTALLATION: • See General Notes on page 45.

- Install on concrete.
- Sized for 2-2x, and 4x.
- Center 2-2x posts on holddown.
- Uses Strong-Drive SDS Heavy-Duty Connector screws supplied with the holdowns to ensure proper fasteners are used.
- Slot in the seat allows for 3/8" of adjustment perpendicular to plate.
- Cut washer required between base and anchor nut. HDC10 models use narrow cut washer with outside diameter of 1 3/4".
- Witness slot in the base to inspect the nut.
- Maximum anchor bolt height above concrete is 2 1/8".
- Aluminum standoff cannot be in contact with preservative-treated wood.
- Strong-Drive SDS Heavy-Duty Connector screws install best with a low speed high torque drill with a 3/8" hex head driver.

CODES: See page 12 for Code Reference Key Chart.

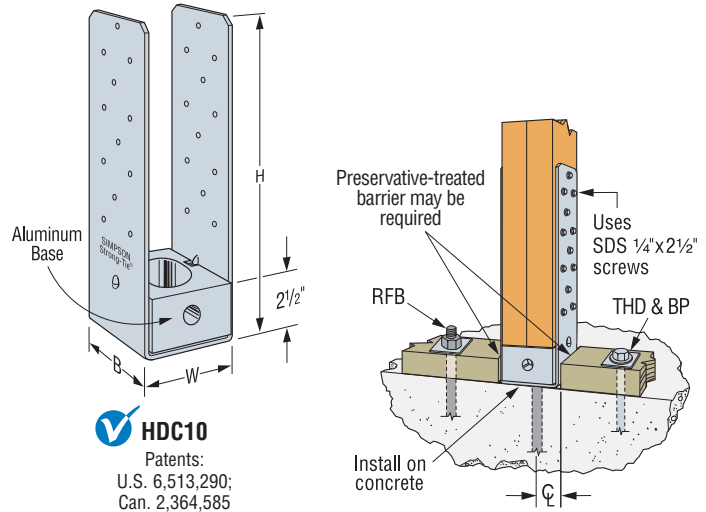

Typical HDC Installation with 2-2x4 Studs
(Similar with 2-2x6 studs)

HDC10
Patents:
U.S. 6,513,290;
Can. 2,364,585

Model No.	Post Size	W	H	B	ϕ	Anchor Bolt	Number of SDS 1/4" x 2 1/2"	Allowable Tension Loads DF/SP (160)	Allowable Tension Loads SPF/HF (160)	Allowable Download DF/SP (100)	Allowable Download DF/SP (160)	Deflection at Highest Allowable Tension Load	Code Ref.
HDC10/22-SDS2.5	2-2x4	3 1/8"	14 3/8"	3"	1 1/8"	7/8"	24	9135	6575	7070	9255	0.054	I6,
HDC10/4-SDS2.5	4x4	3 9/16"	14 7/8"	3"	1 13/16"	7/8"	24	9135	6575	9600	10550	0.054	L8

1. See page 45 for Holdown and Tension Tie General Notes.
2. The HDCs will be limited by wood compression capacity if installed on a sill plate. HDC10/22 will achieve an allowable load of 4005 lbs. on a DFL plate. HDC10/4 will achieve an allowable load of 4940 lbs. on a DFL plate, which does not take deflection into account. Full tension values apply when installed on a sill, deflections may be higher.
3. Higher values may be obtained when HDC is not placed at an edge or with f_c concrete strength > 2500 psi.

MSTD Marriage Strap

The MSTD marriage strap provides an overlapping, in-line splice between an HTT tension tie and a CMSTC16 coiled strap for panelized-roof applications where the roof member adjacent to the wall is too short to develop the required load into the roof diaphragm. The MSTD provides continuity of load without the need to splice the CMSTC16 alongside the HTT which requires additional blocking. Use MSTD4 with HTT4 and MSTD5 with HTT5.

MATERIAL: 16 gauge **FINISH:** Galvanized (G90)

INSTALLATION: • Use all specified fasteners. See General Notes.

- The CMSTC and HTT must be spliced end-to-end without any gap.
- Suitable for use with both 10d and 16d sinker nailing options for the HTT and CMSTC as specified per the Designer.
- To install:
 - Position HTT over the framing (*do not install fasteners yet*).
 - Align CMSTC16 with the end of the HTT.
 - Position MSTD over the two connectors so that nail holes align correctly.
 - Install specified fasteners, filling all nail holes.

CODES: See page 12 for Code Reference Key Chart.

Model No.	Total L	Tension Tie	Fasteners		Allowable Tension Loads	Code Ref.
			CMSTC16	HTT		
MSTD4	18	HTT4	16 - 16d Sinker	12 - 16d Sinker	3100	160
MSTD5	27	HTT5	24 - 16d Sinker	18 - 16 Sinker	4545	

1. Install on minimum 4x4 blocking.
2. 10d common nails may be substituted at 100% of table load.
3. Allowable tension loads include a load duration increase on the fasteners for wind or earthquake with no further increase allowed.
4. **NAILS:** 10d common = 0.148" dia. x 3" long, 16d sinker = 0.148" dia. x 3 3/4" long. See pages 22-23 for other nail sizes and information.

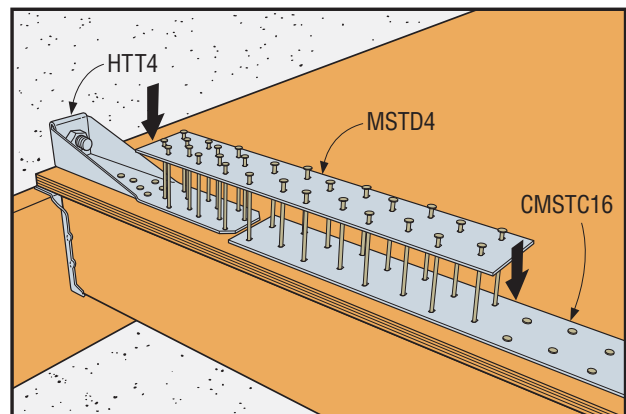
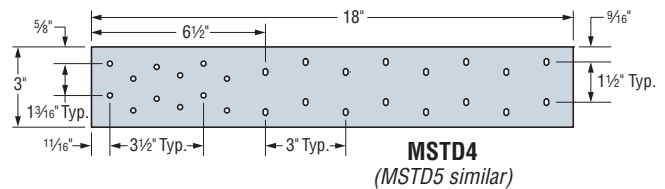

Typical MSTD4 Installation

LTT/HTT Tension Ties

Tension ties offer a solution for resisting tension loads that are fastened with nails. The HTT4 and HTT5 are the latest generation of tension ties. They feature an optimized nailing pattern which results in better performance with less deflection. Designed to meet new code standards, the HTT4 and HTT5 offer higher loads than their predecessors.

HTT5KT is sold as a kit with the holdown, bearing plate washer and Strong-Drive® SD Connector screws. The HTT5-¾ is designed to use a ¾" diameter anchor bolt. ¾" epoxied anchor bolts are commonly used when retrofitting tension ties to horizontal wood members.

The LTT19 Light Tension Tie is designed for 2x joists or purlins and the LTT20B is for nail- or bolt-on applications. The 3" nail spacing makes the LTT20B suitable for wood I-joists with 10dx1½. The LTTI31 is designed for wood chord open web truss attachments to concrete or masonry walls and may also be installed vertically on a minimum 2x6 stud.

MATERIAL: See table

FINISH: Galvanized. May be ordered HDG; contact Simpson Strong-Tie.

INSTALLATION:

- See General Notes on page 45.
- A standard cut washer is required for LTT19 and LTT20B when using ½" or ⅝" anchor bolts. No additional washer is required when using ¾" anchor bolt.

CODES: See page 12 for Code Reference Key Chart.

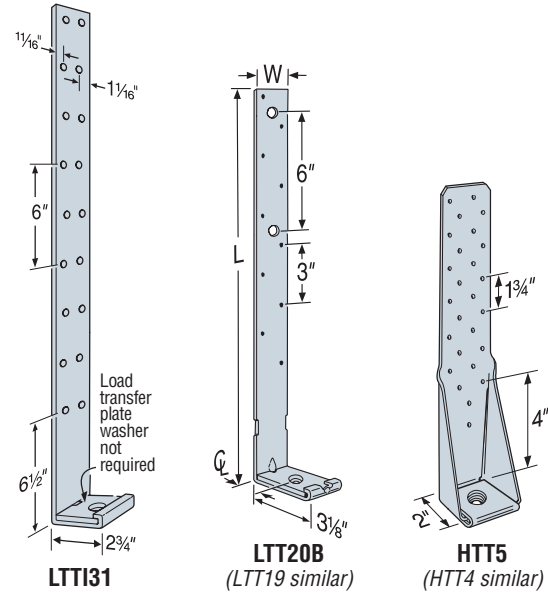

Holdowns & Tension Ties

These products are available with additional corrosion protection. Additional products on this page may also be available with this option, check with Simpson Strong-Tie for details.

These products are approved for installation with the Strong-Drive® SD Connector screw. See page 27 for more information.

Model No.	Strap Mat. (Ga)	Dimensions			Seat Thickness	Fasteners		Minimum Wood Member Size	Allowable Tension Loads (160)		Deflection at Highest Allowable Load	Code Report
		W	L	℄		Anchor Bolts	Fasteners		DF/SP	SPF/HF		
LTT19	16	1 ¼	19 ½	1 ⅝	⅝	1/2, 5/8 or 3/4	8-10dx1 ½	3 x 3 ½	1310	1125	0.180	L19, IP2, F4
							8-10d	3 x 3 ½	1340	1150	0.157	
LTT20B	12	2	19 ¾	1 ½	⅝	1/2, 5/8 or 3/4	10-10dx1 ½	3 x 3 ½	1355	1165	0.195	L19, IP2, F4
							10-10d	3 x 3 ½	1500	1290	0.185	
							2-1 ½" Bolt	3 x 3 ½	1625	1400	0.183	
LTTI31	18	3 ¾	31	1 ⅝	¼	5/8	18-10dx1 ½	3 x 3 ½	1350	1160	0.193	160
							18-10dx1 ½	1 ½ x 5 ½	3000	2580	0.090	
							18-10dx1 ½	3 x 3 ½	3610	3105	0.086	
HTT4	11	2 ½	12 ⅜	1 ⅝	7/16	5/8	18-16dx2 ½	3 x 3 ½	4235	3640	0.123	160
							18-SD #10x1 ½	1 ½ x 5 ½	4455	3830	0.112	
							18-SD #10x1 ½	3 x 3 ½	4455	3830	0.112	
HTT5	11	2 ½	16	1 ⅝	7/16	5/8	26-10dx1 ½	3 x 3 ½	4350	3740	0.120	L19, IP2, F4
							26-10d	3 x 3 ½	4670	4015	0.116	
							26-16dx2 ½	3 x 3 ½	5090 [§]	4375 [§]	0.135	
HTT5KT	11	2 ½	16	1 ⅝	7/16	5/8	26-SD #10x2 ½	3 x 3 ½	5445	5360	0.103	160
HTT5-¾	11	2 ½	16	1 ⅝	7/16	¾	26-10dx1 ½	1 ½ x 5 ½	4065	3495	0.103	160
							26-SD #10x1 ½	1 ½ x 7 ¼	4830	4155	0.100	
							26-16dx2 ½	3 x 3 ½	5090	4275	0.121	

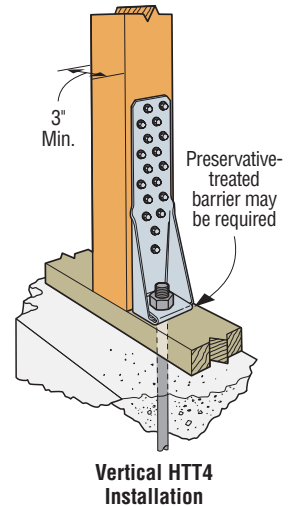

Vertical HTT4 Installation

1. LTT holdowns may not be installed more than 4 ½" above the top of concrete.
2. LTTI31 installed flush with concrete or masonry has an allowable load of 2285 lbs.
3. Allowable load for HTT5 with a BP^{3/8}-2 bearing plate washer installed in the seat of the holdown is 5295 lbs. for DF/SP and 4555 lbs. for SPF/HF.
4. **FASTENERS:** 10dx1 ½ = 0.148 dia. x 1 ½" long, 10d = 0.148" dia. x 3" long, 16dx2 ½ = 0.162" dia. x 2 ½" long, SD #10x1 ½ = 0.161" dia. x 1 ½", SD #10x2 ½ = 0.161" dia. x 2 ½".

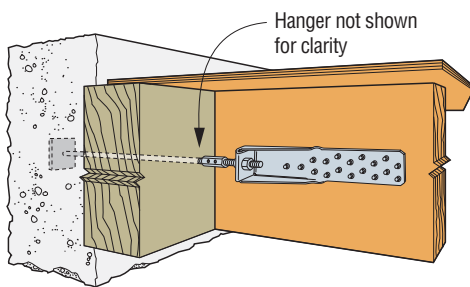

Horizontal HTT Installation

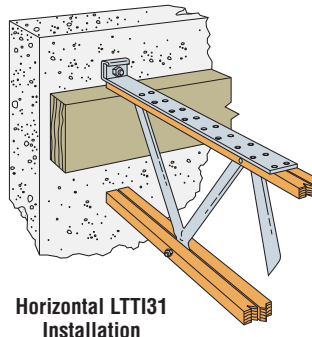

Horizontal LTTI31 Installation

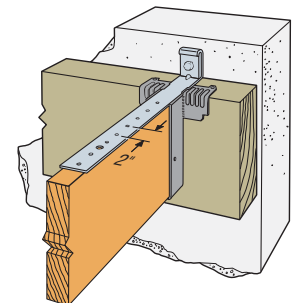

Horizontal LTT19 Installation (LTT20B similar)

HDB/HD Holdowns

Holdowns & Tension Ties

Simpson Strong-Tie offers a wide variety of bolted holdowns offering low-deflection performance for a range of load requirements.

The HD3B is a light-duty holddown designed for use in shearwalls and braced-wall panels, as well as other lateral applications.

The HD5B, HD7B and HD9B bolted holdowns incorporate the proven design of our HDQ8 SDS-style holddown and feature a unique seat design which greatly minimizes deflection under load. HDB holdowns are self jiggling, ensuring that the code-required minimum of seven bolt diameters from the end of the post is met. They can be installed directly on the sill plate or raised above it and are suitable for back-to-back applications where eccentricity is a concern. HDBs are designed to provide loads for intermediate-load-range shearwalls, braced-wall panels and lateral applications.

HD holdowns offer the highest allowable loads, providing high capacity for both vertical and horizontal applications. The HD12 and HD19 are self jiggling, ensuring that the code-required minimum of seven bolt diameters from the end of the post is met. They can be installed back-to-back when eccentricity is an issue.

MATERIAL: See table

FINISH: HD3B/HD5B/HD7B/HD9B – Galvanized;

HD – Simpson Strong-Tie® gray paint

INSTALLATION: • See General Notes on page 45.

- Bolt holes shall be a minimum of 1/32" to a maximum of 1/16" larger than the bolt diameter (per 2012 NDS, section 11.1.3.2).
- Stud bolts should be snugly tightened with standard cut washers between the wood and nut (BPs are required in the City and County of Los Angeles).
- HD and HDB holdowns are self-jiggling and will ensure minimum bolt end distance when installed flush with the sill plate.
- Standard cut washer is required under the anchor nut for HD12 with 1" anchor and HD19 with 1 1/2" anchors.

CODES: See page 12 for Code Reference Key Chart.

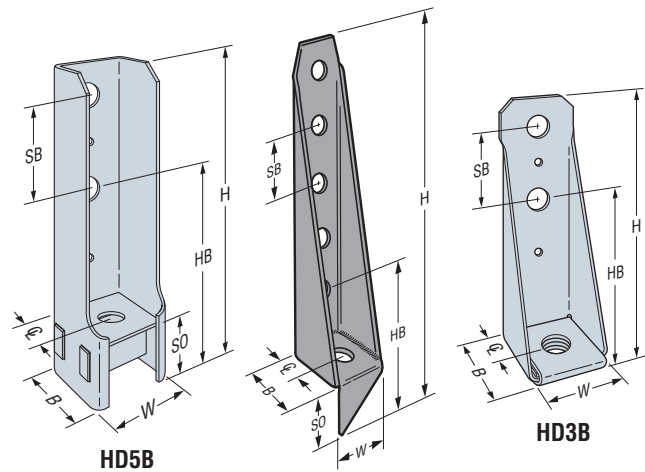

HD5B
(HD7B and HD9B similar)
U.S. Patents
6,006,487; 6,327,831

HD12
(HD19 similar)

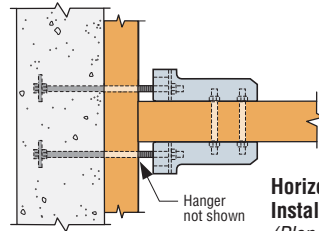

Horizontal HDB Installation
(Plan View)

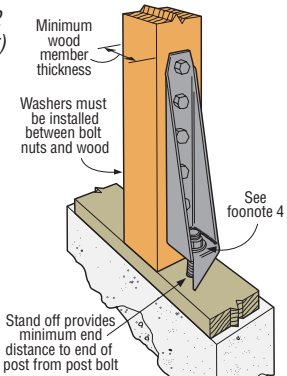

Vertical HD19 Installation

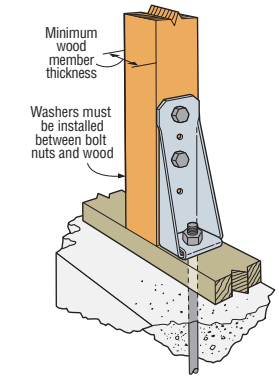

HD3B Vertical Installation

These products are available with additional corrosion protection. Additional products on this page may also be available with this option, check with Simpson Strong-Tie for details.

Model No.	Material		Dimensions (in.)								Fasteners		Minimum Wood Member Thickness	Allowable Tension Loads (160)		Deflection at Highest Allowable Load	Code Ref.
	Base (in)	Body Ga	HB	SB	W	H	B	ϕ	SO	Anchor Dia.	Stud Bolts	DF/SP		SPF/HF			
HD3B	—	12	4 3/4	2 1/2	2 1/2	8 3/4	2 1/4	1 5/16	3/8	5/8	2 - 5/8	1 1/2	1895	1610	0.156	IP3, F28, L21	
												2 1/2	2525	2145	0.169		
												3	3130	3050	0.120		
												3 1/2	3130	3050	0.120		
HD5B	3/16	10	5 1/4	3	2 1/2	9 3/8	2 1/2	1 1/4	2	5/8	2 - 3/4	2 1/2	3750	3190	0.129	IP3, F28, L21	
												3	4505	3785	0.156		
HD7B	3/16	10	5 1/4	3	2 1/2	12 3/8	2 1/2	1 1/4	2	7/8	3 - 3/4	3 1/2	4935	4195	0.150	IP3, F28, L21	
												3	6645	5650	0.142		
												3 1/2	7310	6215	0.154		
HD9B	3/8	7	6 1/8	3 1/2	2 7/8	14	2 1/2	1 1/4	2 3/8	7/8	3 - 7/8	4 1/2	7345	6245	0.155	IP3, F28, L21	
												3 1/2	7740	6580	0.159		
												4 1/2	9920	8435	0.178		
												5 1/2	9920	8430	0.178		
HD12	3/8	3	7	4	3 1/2	20 1/16	4 1/4	2 1/8	3 3/8	1	4 - 1	7 1/4	11775	9215	0.171	IP3, F28, L21	
												3 1/2	11350	9215	0.171		
												4 1/2	12665	10765	0.171		
												5 1/2 x 5 1/2	14220	12085	0.162		
												4 1/2	13335	11055	0.177		
HD19	3/8	3	7	4	3 1/2	24 1/2	4 1/4	2 1/8	3 3/8	1 1/2	5 - 1	7 1/4	15435	13120	0.194	IP3, F28, L21	
												5 1/2 x 5 1/2	15510	12690	0.162		
												7 1/4	16735	14225	0.191		
												7 1/4	16775	12690	0.200		
												5 1/2 x 5 1/2	19070	16210	0.137		

1. To achieve published loads, machine bolts shall be installed with the nut on the opposite side of the holddown. If reversed, the Designer shall reduce the allowable loads shown per NDS requirements when bolt threads are in the shear plane.
2. Lag bolts will not develop the listed loads.

LSTHD/STHD Strap-Tie Holdown



This product is preferable to similar connectors because of
a) easier installation, b) higher loads, c) lower installed cost,
or a combination of these features.

The STHD is an embedded strap-tie holdown offering high load capacity and a staggered nail pattern to help minimize splitting. The STHD incorporates many features that aid correct installation and improve performance. When installed on the forms with the StrapMate® strap holder the unique design of the STHD delivers enhanced stability before and during the pour to help prevent both parallel and perpendicular movement (relative to the form). This results in accurate positioning of the strap and reduced possibility of spalling.

FEATURES

- The nailing pattern allows for nailing to the edges of double 2x's
- Strap nail slots are countersunk to provide a lower nail head profile
- The slots below the embedment line enable increased front-to-back concrete bond and help to reduce spalling
- Rim joist models accommodate up to a 17" clear span without any loss of strap nailing

MATERIAL: LSTHD8, LSTHD8RJ—14 gauge, all others—12 gauge

FINISH: Galvanized

INSTALLATION: • Use all specified fasteners. See General Notes on page 45.

- Use table below for both standard concrete and post-tension slab installations.
- Install before concrete pour with a StrapMate, or other holding device.
- Nail strap from the bottom up. Install strap plumb.
- Strap may be bent one full cycle (bent horizontal 90° then bent vertical) to aid wall placement, but may cause spalling behind the strap. If the spall is 1" or less, measured from the embedment line to the bottom of the spall, full loads apply. 1" to 4" spalls for LSTHD8 achieve 0.9 times table loads. STHD10 and STHD14 achieve full load for spalls less than 4". Any portion of the strap left exposed should be protected against corrosion.
- Other than where noted in the two-pour detail, do not install where:
 - (a) a horizontal cold joint exists within the embedment depth between the slab and foundation wall or footing beneath, unless provisions are made to transfer the load, or the slab is designed to resist the load imposed by the anchor; or
 - (b) slabs are poured over concrete block foundation walls.
- Additional studs attached to the shearwall studs or post may be required by the Designer for wall sheathing nailing.
- Wood shrinkage after strap installation across horizontal members may cause strap to buckle outward.

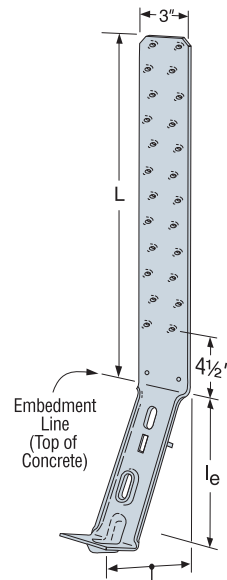

LSTHD8 varies from 4" to 4 1/2"
STHD10, STHD14 varies from 4 3/4" to 5 1/4"

STHD
U.S. Patent
5,813,182

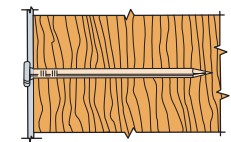

Nails are countersunk for a low-profile strap surface.

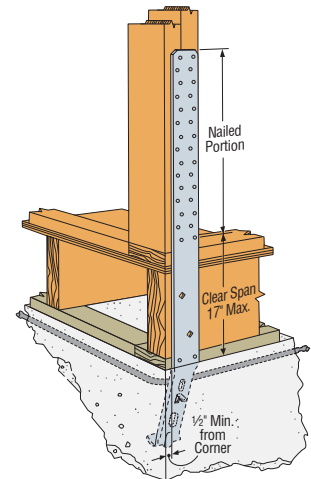

Typical STHD14RJ Rim Joist Application

For Two-Pour Installation for Downturn Footings

- For STHD10 installed through a 4" thick slab, use the equivalent 8" stemwall loads of the LSTHD8.
- For STHD14 installed through a 4" thick slab, use the equivalent 8" stemwall loads of the STHD10.
- For STHD14 installed through a 6" thick slab, use the equivalent 8" stemwall loads of the LSTHD8.

CODES: See page 12 for Code Reference Key Chart.

Tension Loads for STHD Installations

WIND AND SDC A & B – ALLOWABLE TENSION LOADS FOR DF/SP/SPF/HF (160)													
Min. Stem Wall (in)	Model No.		Strap Length (L)		le (in.)	Required Nails	Non-Cracked			Cracked			Code Ref.
	Standard	Rim Joist	Standard (in.)	Rim Joist (in.)			Midwall	Corner	Endwall	Midwall	Corner	Endwall	
6	LSTHD8	LSTHD8RJ	18%	32%	8	20 -16d Sinks	3115	2700	1690	2675	2320	1455	I25. F33
	STHD10	STHD10RJ	24%	38%	10	24 -16d Sinks	3820	3820	2050	3140	3140	1705	
	STHD14	STHD14RJ	26%	39%	14	30 -16d Sinks	5150	5150	3200	5150	5150	3200	
8	LSTHD8	LSTHD8RJ	18%	32%	8	20 -16d Sinks	3115	2700	2230	2675	2320	1915	
	STHD10	STHD10RJ	24%	38%	10	28 -16d Sinks	4755	4120	3145	4195	3500	2585	
	STHD14	STHD14RJ	26%	39%	14	30 -16d Sinks	5345	5345	4210	5345	5345	4210	
SDC C-F – ALLOWABLE TENSION LOADS FOR DF/SP/SPF/HF (160)													
Min. Stem Wall (in)	Model No.		Strap Length (L)		le (in.)	Required Nails	Non-Cracked			Cracked			Code Ref.
	Standard	Rim Joist	Standard (in.)	Rim Joist (in.)			Midwall	Corner	Endwall	Midwall	Corner	Endwall	
6	LSTHD8	LSTHD8RJ	18%	32%	8	16 -16d Sinks	2270	2090	1220	2250	1950	1220	I25. F33
	STHD10	STHD10RJ	24%	38%	10	18 -16d Sinks	2750	2750	1615	2640	2640	1435	
	STHD14	STHD14RJ	26%	39%	14	22 -16d Sinks	3695	3695	2685	3695	3695	2685	
8	LSTHD8	LSTHD8RJ	18%	32%	8	16 -16d Sinks	2615	2125	1635	2250	1950	1610	
	STHD10	STHD10RJ	24%	38%	10	20 -16d Sinks	3400	2940	2295	3400	2940	2175	
	STHD14	STHD14RJ	26%	39%	14	24 -16d Sinks	3815	3815	3500	3815	3815	3500	

1. Allowable loads are for wind or seismic loading. Nail quantities reflect an increase for duration of load with no further increase allowed. Reduce where other loads govern.
2. Concrete shall have a minimum concrete strength, f_c of 2500 psi.
3. 10d common (3" long x 0.148") or 10d x 2 1/2" (2 1/2" long x 0.148") nails may be used as a direct replacement for the required nails shown in the table with no load reduction when installed directly over framing or over 1/2" max. structural sheathing.
4. Use the specified number of nails listed in table or as specified. In many cases, not all nail holes will be filled. Nail strap from the bottom up.
5. Deflection at highest allowable loads for install over wood double studs

6. are as follows: Installed on framing: LSTHD8 = 0.089", STHD10 = 0.117" and STHD14 = 0.118". Installed over 1/2" maximum structural sheathing: LSTHD8 = 0.114", STHD10 = 0.146" and STHD14 = 0.164".
6. Multiply Seismic and Wind ASD load values by 1.4 or 1.6 respectively to obtain LRFD capacities.
7. Per 2009 and 2012 IBC Section 1613.1, detached one- and two-family dwellings in Seismic Design Category (SDC) C may use "Wind and SDC A&B" allowable loads.
8. Minimum center-to-center spacing is 3 times the required embedment (S_{min} = 3x_{le}) for STHD's acting in tension simultaneously. Midwall install is based on 1.5x_{le} end distance.
9. See T-SCLC COLUMN for installation on structural composite lumber posts or columns.
10. For brick ledge applications, use full loads shown for STHD14 installed in 8" stemwall.
11. **NAILS:** 16d sinker = 0.148" dia. x 3 1/4" long. See pages 22-23 for other nail sizes and information.

LSTHD/STHD Strap-Tie Holdown

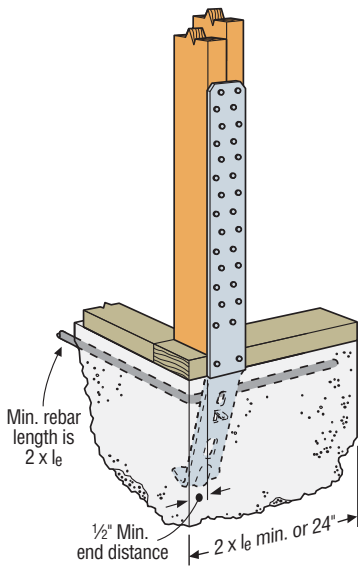

Typical STHD14
Corner Installation

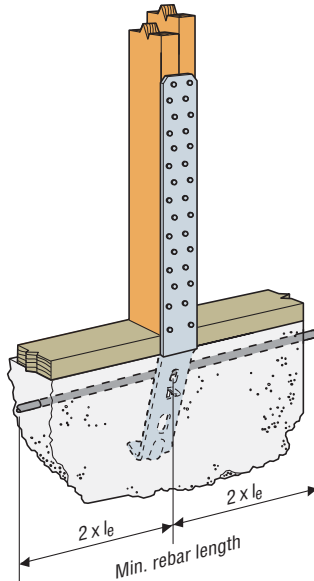

Typical STHD14
Mid Wall Installation

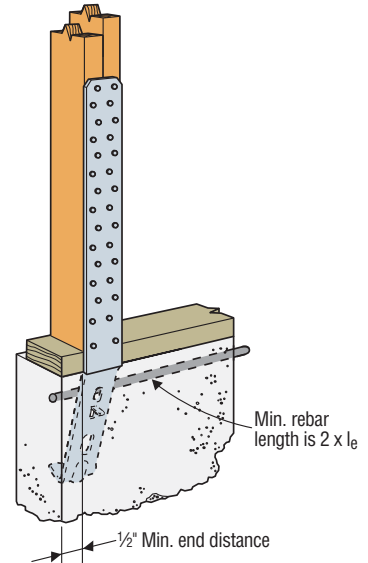

Typical STHD14
End Wall Installation

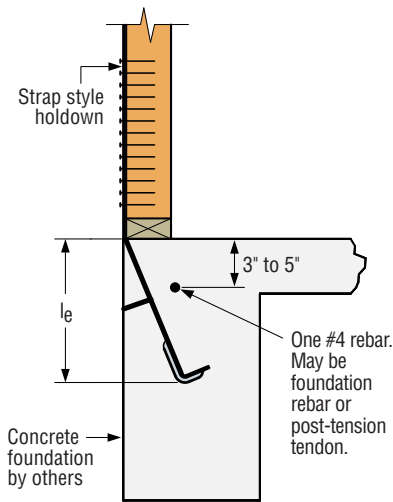

Single Pour Rebar Installation

*Maintain minimum rebar cover, per ACI-318 concrete code requirements.

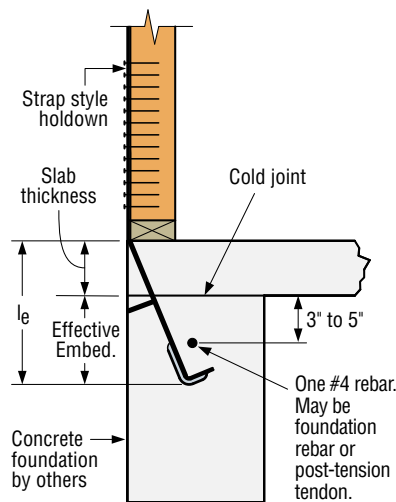

Two Pour Installation
for Downturn Footings

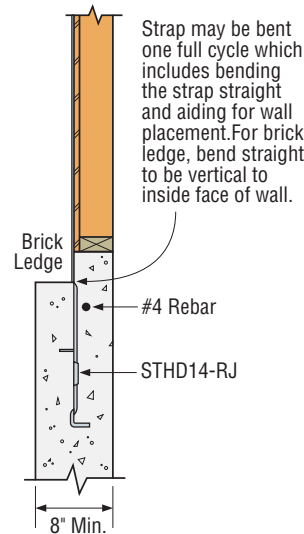

Brick Ledge Installation
with Step

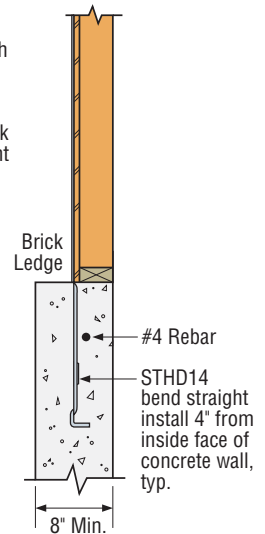

Brick Ledge Installation
without Step

Spall Reduction System for STHD Holddown

FEATURES

- Built-in tab.
- StrapMate® locator line.
- Additional diamond hole in RJ versions.

BENEFITS

- Built-in Tab:**
- Reduces spalling and costly retrofits.
 - No additional labor to install.
 - Holds STHD away from form board.

StrapMate Locator Line:

- Easy inspection to ensure proper location.
- Allows adjustment without removing STHD.

Additional Diamond Hole:

- One more fastener to help prevent the STHD RJ models from bowing out at the rim joist section.

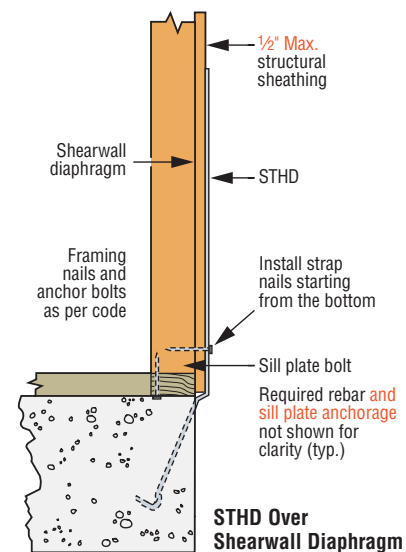
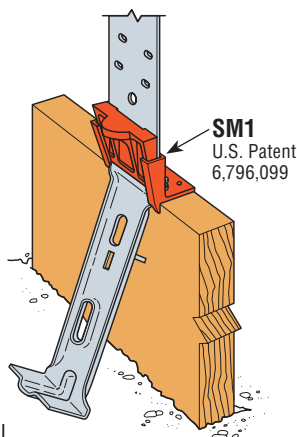

PA Strap Tie Holdowns

PA strap tie holdowns are wood-to-concrete connectors that connect studs to the foundation to satisfy engineering and code requirements.

MATERIAL: 12 gauge

FINISH: Galvanized or ZMAX® coating

INSTALLATION:

- Use all specified fasteners. See General Notes.
- For additional length, an MST strap can be attached using ½" bolts through existing holes.
- Refer to technical bulletin T-PAUPLIFT for additional information.

CODES: See page 12 for Code Reference Key Chart.

These products are available with additional corrosion protection. Additional products on this page may also be available with this option, check with Simpson Strong-Tie for details.

These products are approved for installation with the Strong-Drive® SD Connector screw. See page 27 for more information.

Wind and SDC A & B – Allowable Tension Loads

Model No.	Strap Length, L (in.)	l _e (in.)	Non-Cracked Concrete		Cracked Concrete		Code Ref.
			Required Nails	Tension	Required Nails	Tension	
PA51	51	4	10 -10d Common	2025	10 -10d Common	2025	I25
PA68	70	4	10 -10d Common	2025	10 -10d Common	2025	

SDC C-F – Allowable Tension Loads

Model No.	Strap Length, L (in.)	l _e (in.)	Non-Cracked Concrete		Cracked Concrete		Code Ref.
			Required Nails	Tension	Required Nails	Tension	
PA51	51	4	10 -10d Common	2025	10 -10d Common	1980	I25
PA68	70	4	10 -10d Common	2025	10 -10d Common	1980	

1. Allowable loads have been increased for earthquake or wind load durations with no further increases allowed.
2. Concrete shall have a minimum concrete strength, f'c of 2500 psi.
3. Strong-Drive® SD9x1½ (0.131"x1½") Connector screws may be substituted for nails with no reduction.
4. **NAILS:** 10d = 0.148" dia. x 3" long. See pages 22-23 for other nail sizes and information.

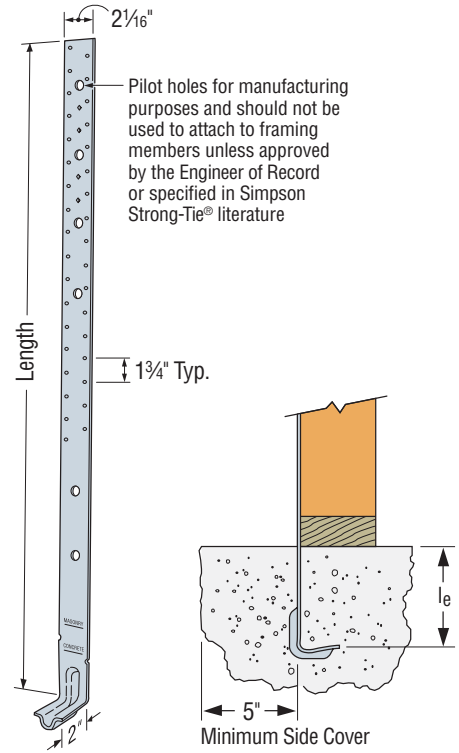

PA51
(PA68 similar)

Typical PA Connecting Stud To Foundation

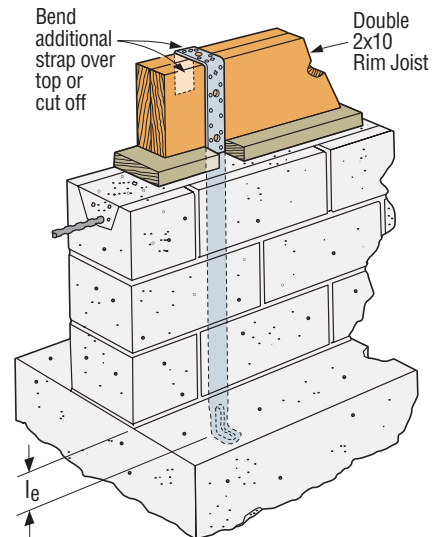

Typical PA51 Installation
(PA68 similar)

PA/HPA Purlin Anchors

Holdowns & Tension Ties

PA/HPA purlin anchors offer solutions for wood to concrete and concrete block connections which satisfy code requirements. The PAs dual embedment line allows installation in concrete or concrete block.

MATERIAL: PA—12 gauge; HPA—10 gauge

FINISH: Galvanized. PA's available HDG or ZMAX® coating

INSTALLATION:

- Use all specified fasteners; some models have extra fastener holes. See General Notes.
- Purlin Anchor must hook around rebar.
- Allowable loads are for a horizontal installation into the side of a concrete or masonry wall.
- Strap may be bent one full cycle. (*Bent vertical 90° then bent horizontal.*)

EDGE DISTANCE—Minimum concrete edge distance is 5".

Minimum concrete block left-to-right edge distance is 20".

CONCRETE BLOCK WALL—The minimum wall specifications are:

- A** One #4 vertical rebar, 32" long, 16" each side of anchor;
- B** Two courses of grout filled block above and below the anchor (*no cold joints allowed*);
- C** A horizontal bond beam with two #4 rebars, 40" long, a maximum of two courses above or below the anchor.
- D** Minimum masonry compressive strength, $f'_m = 1500$ psi.

OPTIONS: See LTT and HTT Tension Ties for alternate retrofit solutions.

CODES: See page 12 for Code Reference Key Chart.

ASCE7-10 12.11.2.2.5 states:

... Diaphragm to structural wall anchorage using embedded straps shall have the straps attached to or hooked around the reinforcing steel, or otherwise terminated to effectively transfer forces to the reinforcing steel.

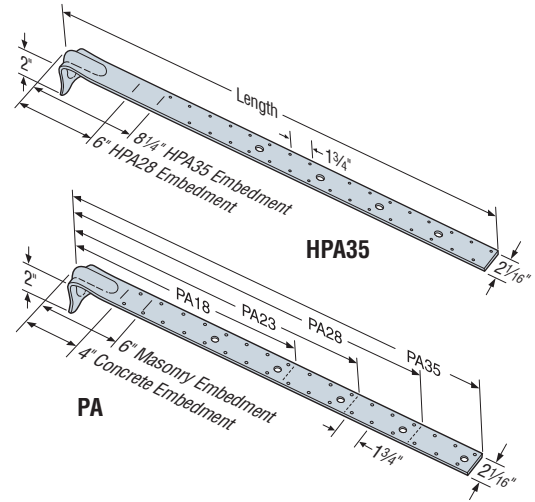

These products are available with additional corrosion protection. Additional products on this page may also be available with this option, check with Simpson Strong-Tie for details.

Wind and SDC A & B - Allowable Tension Loads

Max. Ledger Size	Model No.	Strap Length, L (in.)	le (in.)	Non-Cracked Concrete		Cracked Concrete		Max. Allowable Strap Tensile Capacity	Masonry Installation	Code Ref.
				Required Nails	Tension	Required Nails	Tension			
4x Ledger	PA18	18½	4	12 -10d Common	2430	12 -10d Common	2360	NA	1895	125
	PA23	23¾	4	16 -10d Common	3220	12 -10d Common	2360	NA	2815	
	PA28	29	4	16 -10d Common	3370	12 -10d Common	2360	NA	2815	
	PA35	35	4	16 -10d Common	3370	12 -10d Common	2360	NA	2815	
	HPA28	32½	6	22 -10d Common	5145	20 -10d Common	4675	NA	—	
	HPA35	38½	8¼	22 -10d Common	5145	22 -10d Common	5145	NA	—	

SDC C-F - Allowable Tension Loads

Max. Ledger Size	Model No.	Strap Length, L (in.)	le (in.)	Non-Cracked Concrete		Cracked Concrete		Max. Allowable Strap Tensile Capacity	Masonry Installation	Code Ref.
				Required Nails	Tension	Required Nails	Tension			
4x Ledger	PA18	18½	4	12 -10d Common	2430	10 -10d Common	1980	3220	1895	125
	PA23	23¾	4	14 -10d Common	2830	10 -10d Common	1980	3220	2815	
	PA28	29	4	14 -10d Common	2830	10 -10d Common	1980	3935	2815	
	PA35	35	4	14 -10d Common	2830	10 -10d Common	1980	3935	2815	
	HPA28	32½	6	22 -10d Common	5145	18 -10d Common	4090	5145	—	
	HPA35	38½	8¼	22 -10d Common	5145	22 -10d Common	5145	5145	—	

1. Allowable loads have been increased for earthquake or wind load durations with no further increases allowed.
2. Deflection at highest allowable loads are as follows: PA18 = 0.087", PA23 = 0.118", PA28 = 0.085", PA35 = 0.085", PA51 & 68 = 0.010", HPA28 = 0.133" and HPA35 = 0.132".
3. Multiply Seismic and Wind ASD load values by 1.4 or 1.6 respectively to obtain LRFD capacities.
4. Minimum center-to-center spacing is 3 times the required embedment. Standard installation is based on minimum 5" end distance.
5. For wall anchorage systems in SDC C-F, the maximum allowable strap tensile capacity shall not be less than 1.4 times the ASD anchor design load per ASCE7-10 12.11.2.2.2.
6. Nail quantities are based on Douglas Fir (DF) and Southern Pine (SP). For use on Spruce-Pine-Fir (SPF) or Hem-Fir (HF) nail quantities must be increased by 1.15 to achieve allowable loads – alternatively, loads may be decreased by a 1.15 factor.
7. Concrete shall have a minimum concrete strength, f'_c of 3000 psi.
8. For Masonry Installation Loads, see 'Non-Cracked Concrete' for Required Nails.
9. 10d x 1½" nails may be substituted for 10d commons with no load reduction and with a 15% increase in deflection. For installation over sheathing use 3" minimum nail lengths.
10. Minimum $f'_m = 1500$ psi for masonry.
11. **NAILS:** 10d = 0.148" dia. x 3" long. See pages 22-23 for other nail sizes and information.

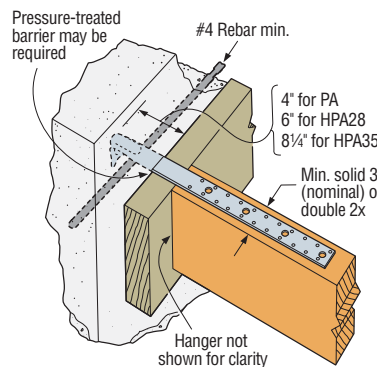
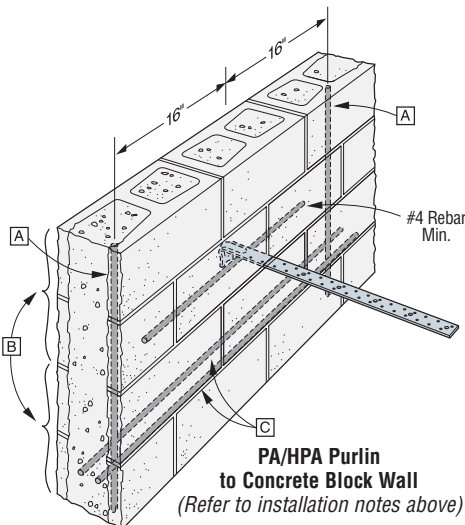

PA/HPA Purlin to Concrete Wall

For I-Joist applications see page 139.

RPBZ Retrofit Post Base

The new RPBZ Retrofit Post Base is designed to reinforce existing posts and columns. The single, versatile model will fit on any size post consisting of a double 2x4 or larger. RPBZ can also be used to reinforce new post-base connections, such as braced carports, patio covers, decks and other structures. The RPBZ can be installed with the CPS composite plastic standoff to meet a 1" post standoff code requirement. A single RPBZ can be installed on a post that is flush to a corner, and two RPBZs can be installed at away from edge conditions to fortify the post base connection to resist both wind and seismic forces.

Simpson Strong-Tie® Strong-Drive® SDS Heavy-Duty Connector screws install easily and provide excellent holding strength for post-to-flange connections. Additionally, the RPBZ can be purposed as a temporary base fixture for posts when shoring beams. RPBZ comes standard in ZMAX® finish to meet exposure conditions in many environments. See additional Corrosion information at www.strongtie.com/corrosion.

MATERIAL: 12 gauge

FINISH: ZMAX coating

INSTALLATION: • Use all specified fasteners. See General Notes.

- Simpson Strong-Tie ¼" x 1½" Strong-Drive SDS Heavy-Duty Connector and base connection fasteners are not provided with RPBZ. Simpson Strong-Tie CPS series Composite Post Stand-Off sold separately.
- Post bases do not provide adequate resistance to prevent members from rotating about the base and therefore are not recommended for non top-supported installations, such as fences or unbraced car ports.

CODES: See page 12 for Code Reference Key Chart.

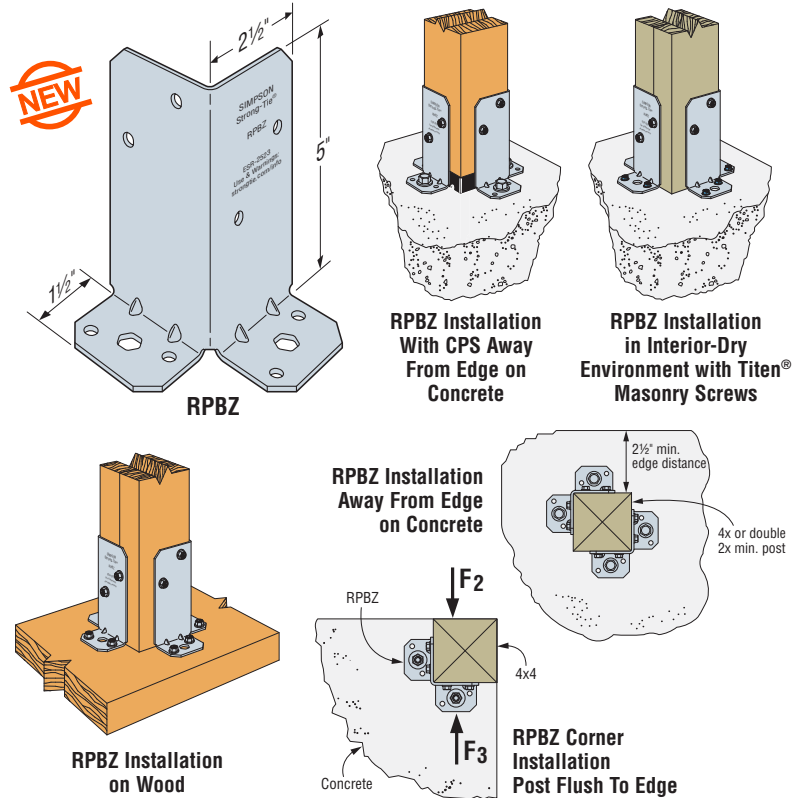

These products are available with additional corrosion protection. Additional products on this page may also be available with this option, check with Simpson Strong-Tie for details.

RPBZ Connector-Only Values

Model No.	Part Qty.	Post Size ^{6,7}	Fasteners				Allowable Connector Loads (DF/SP)			Code Ref.
			Base Connection ^{4,5}		Post		Uplift (160)	F ₂ (160)	F ₃ (160)	
			Type	Qty.	Type	Qty.				
RPBZ	1	4x, 6x	¾" Anchor Bolt or ¼" Titen® Screw	2 Anchors or 4 Screws	¼x1½" SDS	4	1500	860	485	160
				4 Anchors or 8 Screws		8	2235	1115	1115	
	1	4x, 6x	¼x3" SDS	¼x1½" SDS	4	4	1335	860	485	
					8	8	2235	1115	1115	
					4	4	845	860	485	
					8	8	1825	1115	1115	

RPBZ Anchorage-to-Concrete Values

Model No.	Part Qty.	Post Size ^{3,4}	Fasteners		Allowable Anchorage Loads					
			Base Connection		Uplift		F ₂	F ₃		
			Type	Qty.	Uncracked	Cracked				
RPBZ	1	4x, 6x	Titen ¼"x1¼"	4	Corner – Post Flush to Edge					
					¾" Diameter Anchor	2	750	—	820	820
	1	4x, 6x	Titen ¼"x1¼"	4	Away From Edge					
					¾" Diameter Anchor	2	850	—	935	935
					Titen ¼"x1¼"	8	2190	1565	1265	1265
					¾" Diameter Anchor	4	1500	—	1645	1645
2	4	¾" Diameter Anchor	4	3635	2595	1730	1730			

1. Allowable load for design shall not exceed minimum of Connector Only Value and Anchorage to Concrete Value.
2. Allowable connector loads are based on DF/SP lumber. For SPF/HF, multiply table loads by 0.72.
3. Double 2x4s may be used in lieu of 4x4 post.
4. For installation on 6x members, if four RPBZs are used, allowable loads may be taken to be 1.5 x the tabulated two-part value.
5. For installations into concrete, minimum compressive strength, $f'_c = 2500$ psi. Designer is responsible for concrete member uplift design.
6. Away From Edge loads require face of wood post to be a minimum of 2½" away from near edge of concrete on all four sides of the post.
7. Allowable anchorage to concrete uplift and shear loads for the ¾" diameter anchors are calculated per ACI 318-11, Appendix D. Shear loads assume cracked concrete

8. while uplift loads consider both cracked and uncracked concrete values and all are qualified for Wind and Seismic Design Categories A&B.
8. Embedment depth for these post-install anchors must be a minimum 2¼" and are for use with SET-XP® or AT-XP® structural anchoring adhesives or Titen HD® screw anchors.
9. Allowable uplift and shear loads for the Titen® masonry screws do not carry a particular "cracked" or "uncracked" designation.
10. Titen® masonry screws and Titen HD screw anchors should only be used in interior-dry and non-corrosive environments.
11. Threads on Strong-Drive® SDS Heavy-Duty Connector screws into wood framing must be fully engaged into a structural wood member.

ABA/ABU/ABW Adjustable and Standoff Post Bases

Additional standoff bases are on page 232.

The AB series of retrofit adjustable post bases provide a 1" standoff for the post, are slotted for adjustability and can be installed with nails, Strong-Drive® SD Connector screws or bolts (ABU). Depending on the application needs, these adjustable standoff post bases are designed for versatility, cost-effectiveness and maximum uplift performance.

Features:

- The slot in the base enables flexible positioning around the anchor bolt, making precise post placement easier
- The 1" standoff helps prevent rot at the end of the post and meets code requirements for structural posts installed in basements or exposed to weather or water splash

MATERIAL: Varies (see table)

FINISH: All galvanized, most offered in ZMAX®; see Corrosion Information, pages 13-15.

INSTALLATION: • Use all specified fasteners. See General Notes.

- See our *Anchoring and Fastening Systems for Concrete and Masonry* catalog, or visit www.strongtie.com for retrofit anchor options or reference technical bulletin T-ANCHORSPEC.
- Post bases do not provide adequate resistance to prevent members from rotating about the base and therefore are not recommended for non top-supported installations (such as fences or unbraced carports).
- Place the base, load transfer plate and nut on the anchor bolt. Loosely tighten the nut.

ABW—Place the standoff base and then the post in the ABW and fasten on three vertical sides, using nails or Strong-Drive SD Connector screws.

- Make any necessary adjustments to post placement and tighten the nut securely on the anchor bolt.
- Bend up the fourth side of the ABW and fasten using the correct fasteners.

ABU—Place the standoff base and then the post in the ABU.

- Fasten using nails or Strong-Drive SD Connector screws or bolts (ABU88Z, ABU1010Z – SDS optional).

ABA—Place the post in the ABA.

- Fasten using nails or Strong-Drive SD Connector screws.

CODES: See page 12 for Code Reference Key Chart.

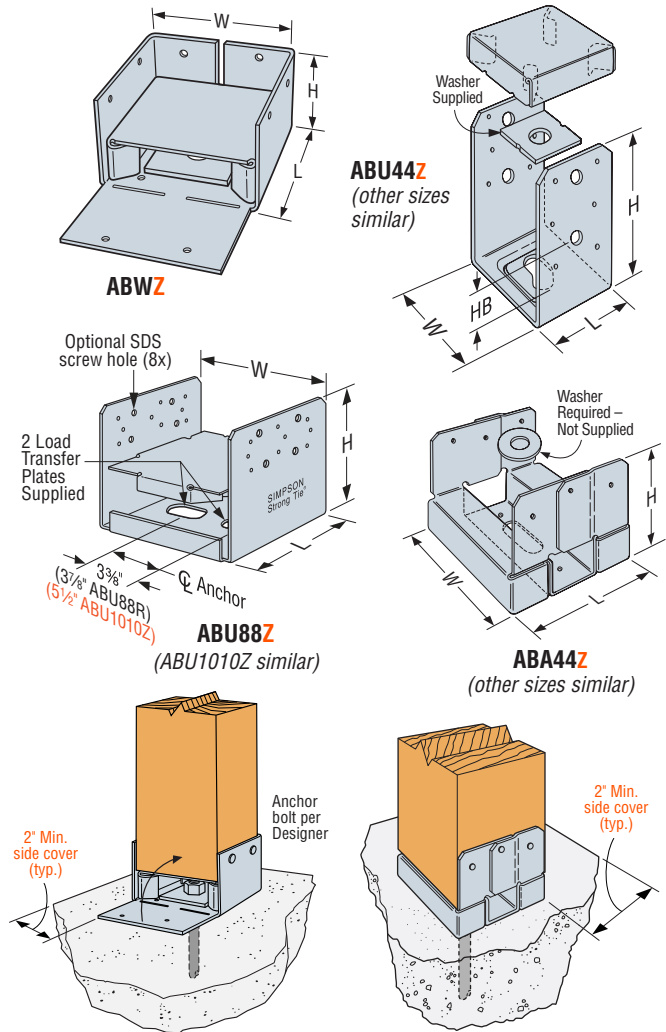

These products are available with additional corrosion protection. Additional products on this page may also be available with this option, check with Simpson Strong-Tie for details.

These products are approved for installation with the Strong-Drive® SD Connector screw. See page 27 for more information.

Typical ABWZ Installation

Typical ABA44Z Installation

Model No.	Nominal Post Size	Material		Dimensions (in.)				Fasteners				Allowable Loads			Code Ref.
		Base (Ga)	Strap (Ga)	W	L	H	HB ⁶	Anchor Dia. (in.)	Nails	Machine Bolts		Uplift		Down (100)	
										Qty.	Dia.	Nails	Bolts		
ABA44Z	4x4	16	16	3 1/16	3 3/8	3 1/16	—	1/2	6-10d	—	—	555	—	6000	I3, F1, L5
ABW44Z	4x4	16	16	3 1/16	3 3/8	2 1/4	—	1/2	8-10d	—	—	1005	—	7180	170
ABU44Z	4x4	16	12	3 1/16	3	5 1/2	1 3/4	5/8	12-16d	2	1/2	2200	2160	6665	I3, F1, L2, L5
ABU44RZ	Rough 4x4	16	12	4	4	5 1/4	1 1/2	5/8	12-16d	2	1/2	2200	2160	6665	I3, F1, L5
ABA44RZ	Rough 4x4	16	16	4 1/16	3 3/8	2 13/16	—	1/2	6-10d	—	—	555	—	8000	I3, F1, L2, L5
ABW44RZ	Rough 4x4	16	16	4	4 1/16	1 32/33	—	1/2	8-10d	—	—	835	—	7180	170
ABW46Z	4x6	12	16	3 1/16	5 1/16	3	—	1/2	10-10d	—	—	845	—	4590	170
ABA46Z	4x6	14	14	3 1/16	5 1/16	3 3/8	—	5/8	8-16d	—	—	700	—	9435	I3, F1, L5
ABU46Z	4x6	12	12	3 1/16	5	7	2 5/8	5/8	12-16d	2	1/2	2300	2300	10335	I3, F1, L2
ABU46RZ	Rough 4x6	12	12	4	6	6 3/4	2 3/8	5/8	12-16d	2	1/2	2300	2300	10335	170
ABW46RZ	Rough 4x6	12	16	4	6	2 13/16	—	1/2	10-10d	—	—	780	—	4590	170
ABA46RZ	Rough 4x6	14	14	4 1/16	5 1/16	2 7/8	—	5/8	8-16d	—	—	700	—	12000	I3, F1, L5
ABU5-5	5 1/2 x 5 1/2	12	10	5 1/4	5	6 1/16	1 3/4	5/8	12-16d	2	1/2	2235	2235	12000	170
ABU5-6	5 1/2 x 6	12	10	6 1/8	5	6 1/16	1 3/4	5/8	12-16d	2	1/2	2235	2235	12000	170
ABA66Z	6x6	14	14	5 1/2	5 1/4	3 3/8	—	5/8	8-16d	—	—	720	—	10665	I3, F1, L5
ABW66Z	6x6	12	14	5 1/2	5 1/16	3	—	1/2	12-10d	—	—	1190	—	12935	170
ABU66Z	6x6	12	10	5 1/2	5	6 1/16	1 3/4	5/8	12-16d	2	1/2	2300	2300	12000	I3, F1, L2
ABU66RZ	Rough 6x6	12	10	6	6	5 13/16	1 1/2	5/8	12-16d	2	1/2	2300	2300	12000	170
ABA66RZ	Rough 6x6	14	14	6	5 3/16	2 7/8	—	5/8	8-16d	—	—	720	—	12665	I3, F1, L5
ABW66RZ	Rough 6x6	12	14	6	6	2 13/16	—	1/2	12-10d	—	—	1065	—	12935	170
ABU88Z	8x8	14	12	7 1/2	7	7	—	2 - 5/8	18-16d	—	—	2320	—	24335	I3, F1
ABU88R	Rough 8x8	14	12	8	7	7	—	2 - 5/8	18-16d	—	—	2320	—	24335	170
ABU1010Z	10x10	12	12	9 1/2	9	7 1/4	—	2 - 5/8	22-16d	—	—	2270	—	32020	170
ABU1010RZ	Rough 10x10	12	12	10	9	7	—	2 - 5/8	22-16d	—	—	2270	—	32020	170

1. Uplift loads have been increased for wind or earthquake with no further increase allowed; reduce where other loads govern.
2. Downloads may not be increased for short-term loading.
3. Specifier to design concrete for uplift capacity.
4. ABU products may be installed with either bolts or nails (not both) to achieve table loads. ABU88Z, ABU88R, ABU1010Z and ABU1010RZ may be installed with 8-1/4"x3" Strong-Drive® SDS Heavy-Duty Connector screws (sold separately) for the same table load.
5. For AB bases, higher download can be achieved by solidly packing grout under 1" standoff plate before installation. Base download on column, grout, or concrete according to the code.
6. HB dimension is the distance from the bottom of the post up to the first bolt hole.
7. Structural composite lumber columns have sides that show either the wide face or the edges of the lumber strands/veneers. For SCL columns, the fasteners for these products should always be installed in the wide face.
8. Downloads shall be reduced where limited by the capacity of the post. See pages 245-246 for common post allowable loads.
9. **NAILS:** 16d = 0.162" dia. x 3 1/2" long, 10d = 0.148" dia. x 3" long. See pages 22-23 for other nail sizes and information.

CPTZ Concealed Post Tie

The CPTZ concealed post base provides a clean, concealed look while providing a 1" standoff height above concrete. The 1" standoff reduces the potential for decay at the post end and satisfies code requirements for posts that are exposed to weather, water splash or in basements.

- The CPTZ is tested and load-rated for uplift, download and lateral load.
- Simpson Strong-Tie saves installers time by providing all the necessary components to make the connection in one box.
- The CPTZ anchorage can either be cast-in-place or retrofitted with adhesive or mechanical anchors.
- Solutions have been calculated per ACI 318, Appendix D to determine their allowable load in different concrete configurations.

MATERIAL: See table below

FINISH: Knife plate, washers and standoff base are ZMAX®-galvanized steel. The standoff base has an additional textured, flat black powder coat finish for aesthetic purposes. The 1/2" diameter drift dowels are mechanically galvanized in accordance with ASTM B695, class 55. If substituting 1/2" diameter machine bolts, a hot-dip galvanized finish is recommended.

INSTALLATION: Use all specified fasteners. See General Notes.

- More extensive installation instructions are available through our Literature Library app or by visiting www.strongtie.com.
- Post bases do not provide adequate resistance to prevent members from rotating about the base and therefore are not recommended for non-braced, or non-top-supported installations.

CODES: See page 12 for Code Reference Key Chart.

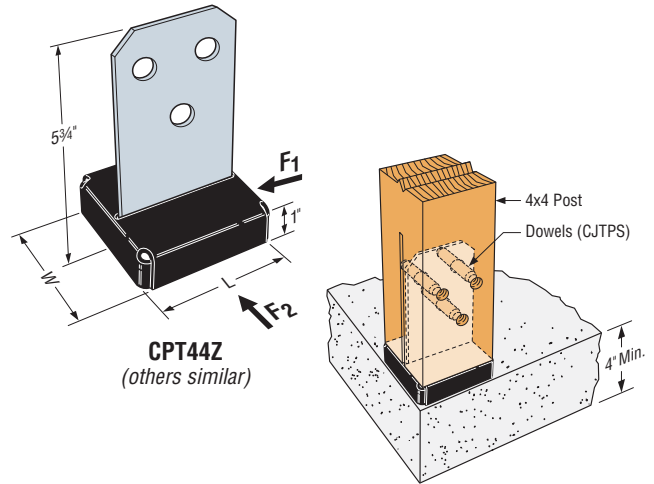

Typical CPT44Z Installation

These products are available with additional corrosion protection. Additional products on this page may also be available with this option, check with Simpson Strong-Tie for details.

Model No.	Post Size	Base (Ga)	Knife Plate (Ga)	Dimensions (in.)		Fasteners				Allowable Loads (DF/SP)				Code Ref.
				W	L	Anchor		Post		Uplift (160)	Down (100)	F ₁ (160)	F ₂ (160)	
						Qty.	Dia.	Qty.	Type ³					
CPT44Z	4x4, RGH 4x4	12	10	3 1/2	3 1/2	2	1/2	3	1/2 x 2 3/4 dowel	3035	11455	600	605	I3, F1
									1/2" MB	3350				
CPT66Z	6x6, RGH 6x6	12	10	5 3/8	5 3/8	2	1/2	3	1/2 x 4 3/4 dowel	4430	21375	655	1025	
									1/2" MB	4475				
CPT88Z	8x8, RGH 8x8	12	10	7 1/4	7 1/4	2	1/2	3	1/2 x 4 3/4 dowel	3625	22805	740	1080	
									1/2" MB	4475				

1. Uplift loads have been increased for wind or earthquake load with no further increase allowed; reduce where other loads govern.
2. Downloads may not be increased for short-term loading and shall not exceed the post capacity. See pages 245-246 for common post capacities.
3. CPTZs are supplied with (3) 1/2" diameter dowel pins.

4. Lag or carriage bolts are not permitted.
5. Structural composite lumber columns have sides that show either the wide face or the edges of the lumber strands/veneers. Values in the tables reflect dowel or bolt installation into the wide face.

CPT44Z = 1 1/16"
CPT66Z and CPT88Z = 2 1/4"

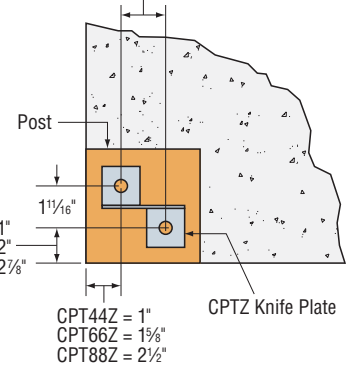

Corner Flush Edge

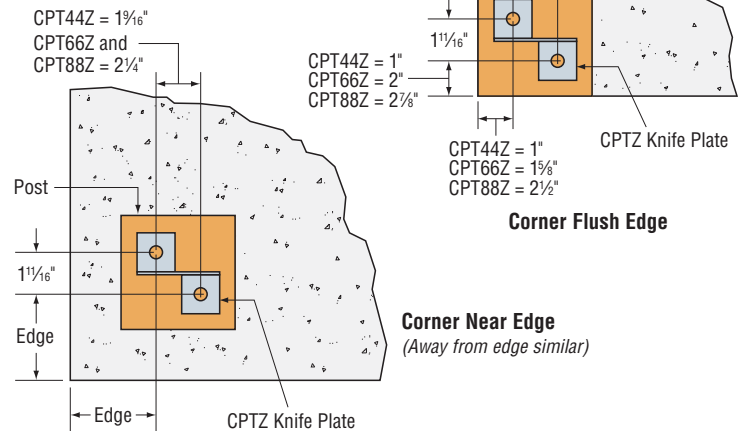

Corner Near Edge (Away from edge similar)

CPTZ Anchorage Using SET-XP® Anchoring Adhesive

Model No.	Embed. (in.)	Edge Distance (in.)	Allowable Uplift		
			Anchorage		CPTZ
			Uncracked	Cracked	
Corner – Flush Edge					
CPT44Z	2 1/4	—	505	405	3035
CPT66Z	2 1/4	—	580	465	4430
CPT88Z	2 1/4	—	625	500	3625
Corner – Near Edge					
CPT44Z	5	4	1480	1185	3035
CPT66Z	5	5	2025	1620	4430
CPT88Z	5	6	2430	1945	3625
Corner – Away from Edge					
CPT44Z	6	9	4005	3205	3035
CPT66Z	7 1/2	11 1/4	5440	4350	4430
CPT88Z	7 1/2	11 1/4	5440	4350	3625
10" Diameter Circular Pedestal					
CPT44Z	5	4	1560	1245	3035
CPT66Z	5	3 3/4	1460	1165	4430
12" Diameter Circular Pedestal					
CPT44Z	5	5	2025	1620	3035
CPT66Z	5	4 3/4	1935	1550	4430
CPT88Z	5	4 3/4	1935	1550	3625

1. Allowable uplift loads are calculated per ACI 318-11, Appendix D considering cracked and uncracked concrete and are qualified for Wind and Seismic Design Categories A & B. No further increases allowed.
2. Edge distance is measured from the center line of the nearest anchor bolt to the edge of concrete.
3. Foundation dimensions are for anchorage only. Foundation design by others. Refer to ACI318-11.
4. Lateral loads (F₁ = F₂) for Corner – Flush Edge conditions are CPT44Z = 395 lbs., CPT66Z = 570 lbs., CPT88Z = 740 lbs. For all other installations using CPTZ with SET-XP® anchoring adhesive, use the allowable loads from the CPTZ table above.
5. Concrete shall have a minimum compressive strength, f_c = 2500 psi.

CPTZ *Concealed Post Tie*

CPTZ Cast-in-Place Anchorage

Model No.	Embedment (in.)	Edge Distance (in.)	Allowable Uplift		
			Anchorage		CPTZ
			Uncracked	Cracked	
Corner – Flush Edge					
CPT44Z	2 1/4	—	870	695	3035
CPT66Z	2 1/4	—	1590	1270	4430
CPT88Z	2 1/4	—	2435	1950	3625
Corner – Away from Edge					
CPT44Z	5	4	3760	3010	3035
CPT66Z	6	5	5390	4310	4430
CPT88Z	6	5	5390	4310	3625
10" Diameter Circular Pedestal					
CPT44Z	5	4	3945	3155	3035
CPT66Z	5	3 3/4	3860	3090	4430
12" Diameter Circular Pedestal					
CPT44Z	5	5	5170	4135	3035
CPT66Z	5	4 3/4	5140	4110	4430
CPT88Z	5	4 3/4	5140	4110	3625

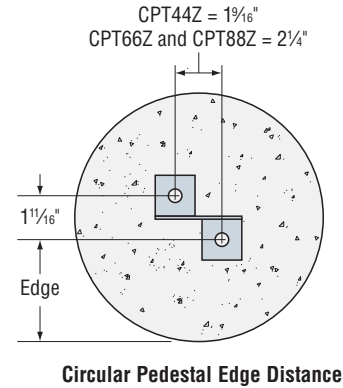

Caps & Bases

1. Allowable uplift loads are calculated per ACI 318-11, Appendix D considering cracked and uncracked concrete and are qualified for Wind and Seismic Design Categories A & B. No further increases allowed.
2. Edge distance is considered to be measured from the center line of the nearest anchor bolt to the edge of concrete.
3. Tabulated anchor embedments will also achieve the maximum lateral loads from the CPTZ table on page 57.
4. Foundation dimensions are for anchorage only. Foundation design by others. Refer to ACI318-11.

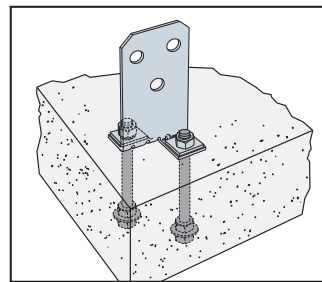

Corner Installation

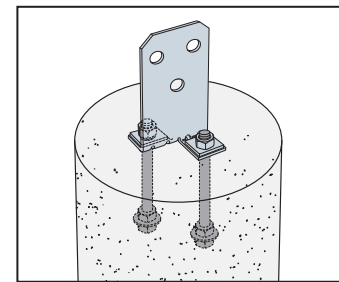

Circular Pedestal Installation

EPB *Elevated Post Bases*

MATERIAL: EPB44A—14 gauge; others—12 gauge base plate, 1 1/16" OD x 8" pipe
FINISH: EPB44A—Galvanized; all others—Simpson Strong-Tie® gray paint (may be ordered HDG); see Corrosion Information, pages 13-15.
INSTALLATION: • Use all specified fasteners. See General Notes.
 • Allows 1" to 2 1/2" clearance above concrete, 2" for EPB44A.
 • Post bases do not provide adequate resistance to prevent members from rotating about the base and therefore are not recommended for non top-supported installations (such as fences or unbraced carports).
OPTIONS: 12" pipe available for EPB44, 46, 66; specify "-12" after model number.
CODES: See page 12 for Code Reference Key Chart.

These products are available with additional corrosion protection. Additional products on this page may also be available with this option, check with Simpson Strong-Tie for details.

These products are approved for installation with the Strong-Drive® SD Connector screw. See page 27 for more information.

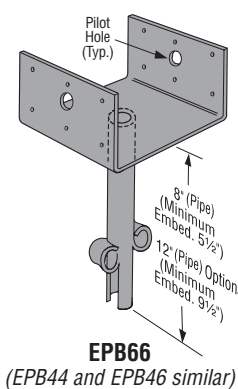

EPB66
(EPB44 and EPB46 similar)

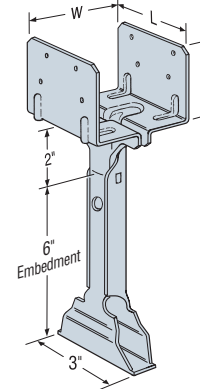

EPB44A

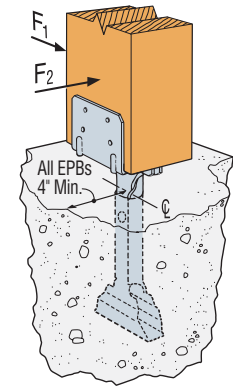

Typical EPB44A Installation

Model No.	W	L	H	Nails	Allowable Loads (160)			Code Ref.
					Non-Cracked Uplift	Cracked Uplift	Down-load	
					Wind and Seismic Design Category A & B			
EPB44A	3 9/16	3	2 5/8	8-16d	1120	785	2670	I28, F1, L27
EPB44	3 9/16	3 1/4	2 5/8	8-16d	1035	725	3465	
EPB46	5 1/2	3 9/16	3	12-16d	1035	725	3465	
EPB66	5 1/2	5 1/2	3	12-16d	1035	725	3465	
Seismic Design Category C-F								
EPB44A	3 9/16	3	2 5/8	8-16d	940	660	2670	I28, F1, L27
EPB44	3 9/16	3 1/4	2 5/8	8-16d	870	605	3465	
EPB46	5 1/2	3 9/16	3	12-16d	870	605	3465	
EPB66	5 1/2	5 1/2	3	12-16d	870	605	3465	

1. Loads may not be increased for short-term loading.
2. Concrete shall have a minimum compressive strength, $f'_c = 2500$ psi.
3. Multiply Seismic and Wind ASD load values by 1.4 or 1.6 respectively to obtain LRFD capacities.
4. In accordance with IBC Section 1613.1, detached one- and two-family dwellings in Seismic Design Category (SDC) C may use "Wind and SDC A&B" allowable loads.
5. Download shall be reduced where limited by the design capacity of the column. See pages 245-246 for common post allowable loads.
6. For lateral loads: F_1 allowable = 815 lbs. for the EPB44A and 985 lbs. for EPB44, 46 and 66. F_2 allowable = 935 lbs. for the EPB44A and 1135 lbs. for EPB44, 46 and 66.
7. Designer is responsible for concrete design.
8. For full loads, nearest concrete edge required is 4" from EPB center line.
9. Structural composite lumber columns have sides that either show the wide face or the edges of the lumber strands/veneers known as the narrow face. Values in the tables reflect installation into the wide face. See Technical Bulletin T-C-SCLCLM for load reductions due to narrow face installations.
10. **NAILS:** 16d = 0.162" dia. x 3 1/2" long. See pages 22-23 for other nail sizes and information.

EPB44T/EPB44PHDG *Elevated Post Bases*

EPB44PHDG can be used both for pier block and cast-in-place installation for 4x4 posts.

MATERIAL: 12 gauge base EPB44T—Threaded rod support $\frac{5}{8}$ "x6" (shipped assembled). EPB44PHDG—Threaded rod support $\frac{3}{4}$ "x6", nut and washer are shipped assembled

FINISH: EPB44T: Base—Galvanized, Threaded Rod—Zinc Plate
EPB44PHDG: HDG; see Corrosion Information, pages 13-15.

INSTALLATION:

• Secured with Anchoring Adhesive:

EPB44T—Drill a $\frac{3}{4}$ " hole 4" deep minimum into the concrete. Clean the hole and fill half full with anchoring adhesive (per installation instructions). Insert the EPB44T and adjust to the desired height. The threaded rod shall be embedded a minimum of $3\frac{1}{2}$ ". To adjust after the anchoring adhesive cures, drill a hole in the center of the post and rotate the post base up or down to the desired height.

EPB44PHDG—Drill a $\frac{7}{8}$ " diameter hole 4" deep minimum and fill the hole halfway with anchoring adhesive. Insert the EPB44PHDG and adjust to the desired height. The threaded rod shall be embedded a minimum of $3\frac{1}{2}$ ". Minimum sidecover is 3" from the center of the threaded rod for both products.

• Go to www.strongtie.com for additional information on hole cleaning procedures and cure time for SET-XP® and AT-XP® anchoring adhesives.

• Supported by a Nut:

EPB44T—Drill a $\frac{3}{4}$ " hole $2\frac{1}{2}$ " deep minimum into concrete. Install a $\frac{5}{8}$ -11 NC nut and cut washer on the threaded rod. (Nut and washer not supplied). Insert EPB44T into the hole and adjust to the desired height.

EPB44PHDG—Drill a 1" diameter hole $3\frac{1}{2}$ " deep minimum. Insert the EPB44PHDG and adjust to the desired height.

• Cast-in-Place:

Embedded end to have a nut and bearing plate with a minimum embedment of 4" from top of concrete to the top of plate.

- Minimum sidecover is 3" from the center of the threaded rod.
- Fully engage at least three threads in the base.
- Post bases do not provide adequate resistance to prevent members from rotating about the base and therefore are not recommended for non top-supported installations (such as fences or unbraced carports).

CODES: See page 12 for Code Reference Key Chart.

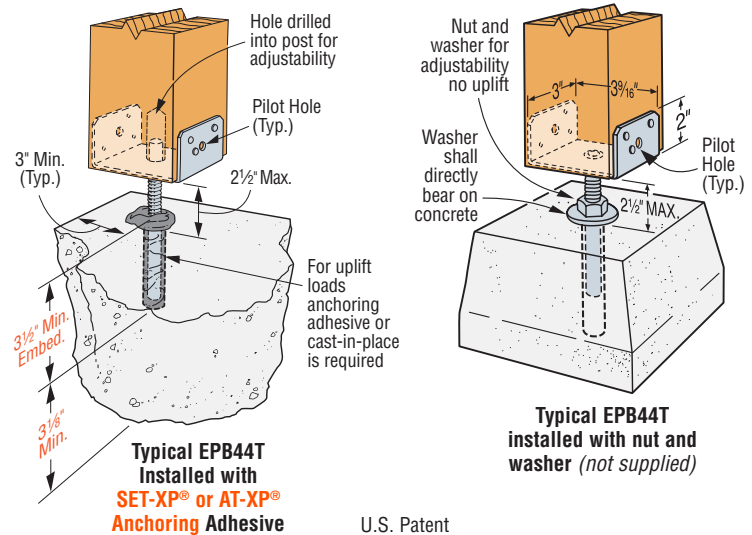

U.S. Patent
5,666,774

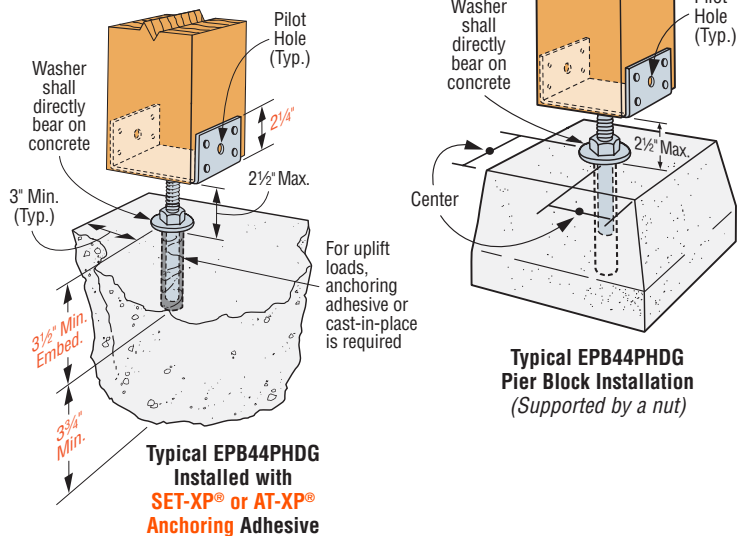

These products are available with additional corrosion protection. Additional products on this page may also be available with this option, check with Simpson Strong-Tie for details.

These products are approved for installation with the Strong-Drive® SD Connector screw. See page 27 for more information.

Model No.	Nails	Anchor Bolt	Allowable Loads (DF/SP)			Code Ref.
			Download (100)	Uplift (160)		
				SET-XP	AT-XP	
EPB44T	6-16d	$\frac{5}{8}$	3275	1130	1140	170
EPB44PHDG	8-16d	$\frac{3}{4}$	3670	1265	985	

1. Loads may not be increased for short term loading.
2. Uplift loads require the threaded rod to be attached to cured concrete with SET-XP or AT-XP anchoring adhesive. Cast-in-place install must have a nut and bearing plate embedded in concrete. Uplift loads do not apply when installed to a pier block.
3. Designer is responsible for concrete design.
4. Downloads shall be reduced where limited by the capacity of the post. See pages 245-246 for common post allowable loads.
5. Structural composite lumber columns have sides that show either the wide face or the edges of the lumber strands/veneers. For SCL columns, the fasteners for these products should always be installed in the wide face. See technical bulletin T-C-SCLCLM for load reductions due to narrow face instructions.
6. Adhesive anchor design assumptions: a) Uncracked dry concrete; b) Anchors not for use in SDC C-F where load combos include earthquake; c) Temperature range 1 or 2 acceptable; d) Periodic special inspection assumed per code report; e) Minimum concrete strength of 2,500 psi.
7. **NAILS:** 16d = 0.162" dia. x $3\frac{1}{2}$ " long. See pages 22-23 for other nail sizes and information.

PB/PBS Regular and Standoff Post Bases

The PBS features a 1" standoff height. It reduces the potential for decay at post and column ends.

MATERIAL: PB—12 gauge; PBS—see table

FINISH: Galvanized. Some products available in ZMAX® or HDG coating; see Corrosion Information, pages 13-15.

INSTALLATION:

- Use all specified fasteners. See General Notes.
- Install either nails or bolts (see page 16 note d).
- Post bases do not provide adequate resistance to prevent members from rotating about the base and therefore are not recommended for non top-supported installations (such as fences or unbraced carports).
- PB—Holes are provided for installation with either 16d commons or ½" bolts for PB66 and PB66R; all other models use 16d commons only. A 2" minimum sidecover is required to obtain the full load.
- PBS—Embed into wet concrete up to the bottom of the 1" standoff base plate. A 2" minimum side cover is required to obtain the full load. Holes in the bottom of the straps allow for free concrete flow.

OPTIONS: PBS available in rough sizes (except for PBS46), contact Simpson Strong-Tie.

CODES: See page 12 for Code Reference Key Chart.

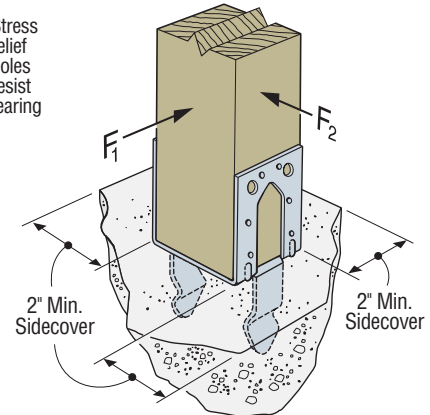
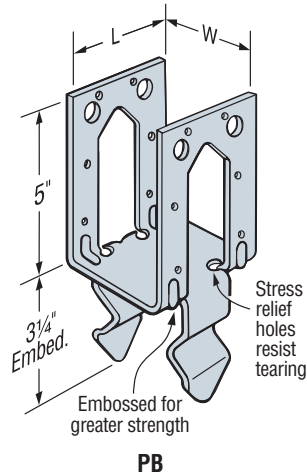

Typical PB Installation

These products are available with additional corrosion protection. Additional products on this page may also be available with this option, check with Simpson Strong-Tie for details.

Model No.	Dimensions		Fasteners		Allowable Loads (160)		Code Ref.
	W	L	Nails	Machine Bolts	Non-Cracked Uplift	Cracked Uplift	
Wind and Seismic Design Category A & B							
PB44	3 ⁹ / ₁₆	3 ¹ / ₄	12-16d	N/A	1485	1040	I28, F1, L27
PB46	5 ¹ / ₂	3 ¹ / ₄	12-16d	N/A	1485	1040	
PB66	5 ¹ / ₂	5 ¹ / ₄	12-16d	2-½" Dia.	1485	1040	
Seismic Design Category C-F							
PB44	3 ⁹ / ₁₆	3 ¹ / ₄	12-16d	N/A	1150	875	I28, F1, L27
PB46	5 ¹ / ₂	3 ¹ / ₄	12-16d	N/A	1150	875	
PB66	5 ¹ / ₂	5 ¹ / ₄	12-16d	2-½" Dia.	1150	875	

1. Loads may not be increased for short-term loading.
2. Concrete shall have a minimum compressive strength, $f'_c = 2500$ psi.
3. Multiply Seismic and Wind ASD load values by 1.4 or 1.6 respectively to obtain LRFD capacities.
4. In accordance with IBC Section 1613.1, detached one- and two-family dwellings in Seismic Design Category (SDC) may use "Wind and SDC A&B" allowable loads.
5. Download shall be limited by the design capacity of the post. See pages 245-246 for common post allowable loads.
6. For lateral loads for all PB models: F_1 allowable = 765 lbs. F_2 allowable = 1325 lbs.
7. Designer is responsible for concrete design.
8. Structural composite lumber columns have sides that either show the wide face or the edges of the lumber strands/veneers known as the narrow face. Values in the tables reflect installation into the wide face. See Technical Bulletin T-C-SCLCLM for load reductions due to narrow face installations.
9. **NAILS:** 16d = 0.162" dia. x 3½" long. See pages 22-23 for other nail sizes and information.

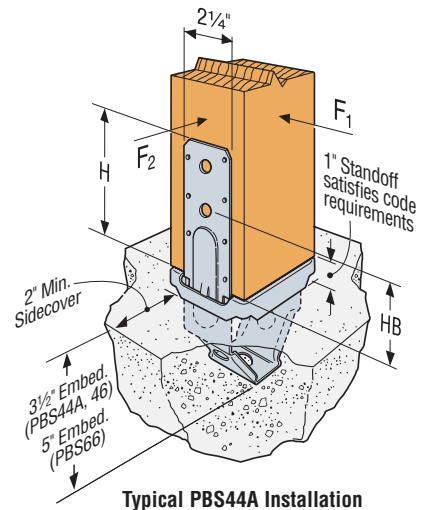

Typical PBS44A Installation

PB/PBS Regular and Standoff Post Bases

These products are available with additional corrosion protection. Additional products on this page may also be available with this option, check with Simpson Strong-Tie for details.

These products are approved for installation with the Strong-Drive® SD Connector screw. See page 27 for more information.

Model No.	Nominal Post Size	Material		Dimensions				Fasteners		Allowable Loads			Code Ref.
		Base (Ga)	Strap (Ga)	W	L	H	HB	Nails	Machine Bolts	Non-Cracked Uplift	Cracked Uplift	Download	
Wind and Seismic Design Category A & B													
PBS44A	4x4	12	14	3 ³ / ₁₆	3 ¹ / ₂	6 ¹ / ₄	3 ³ / ₁₆	14-16d	2 - 1/2" Dia.	1285	900	10975	I28, F1, L27
PBS44R	Rough 4x4	12	14	4	3 ¹ / ₂	6 ¹ / ₄	3 ³ / ₁₆	14-16d	2 - 1/2" Dia.	1285	900	10975	170
PBS46	4x6	12	14	3 ³ / ₁₆	5 ⁷ / ₁₆	6 ⁹ / ₁₆	3 ³ / ₈	14-16d	2 - 1/2" Dia.	1285	900	14420	I28, F1, L27
PBS66	6x6	12	12	5 ¹ / ₂	5 ³ / ₈	6 ¹ / ₂	3 ¹¹ / ₁₆	14-16d	2 - 1/2" Dia.	2165	2165	14420	F1, L27
PBS66R	Rough 6x6	12	14	6	5 ³ / ₈	6 ¹ / ₂	3 ¹¹ / ₁₆	14-16d	2 - 1/2" Dia.	2165	2165	14420	170
Seismic Design Category C-F													
PBS44A	4x4	12	14	3 ³ / ₁₆	3 ¹ / ₂	6 ¹ / ₄	3 ³ / ₁₆	14-16d	2 - 1/2" Dia.	1080	755	10975	I28, F1, L27
PBS44R	Rough 4x4	12	14	4	3 ¹ / ₂	6 ¹ / ₄	3 ³ / ₁₆	14-16d	2 - 1/2" Dia.	1080	755	10975	170
PBS46	4x6	12	14	3 ³ / ₁₆	5 ⁷ / ₁₆	6 ⁹ / ₁₆	3 ³ / ₈	14-16d	2 - 1/2" Dia.	1080	755	14420	I28, F1, L27
PBS66	6x6	12	12	5 ¹ / ₂	5 ³ / ₈	6 ¹ / ₂	3 ¹¹ / ₁₆	14-16d	2 - 1/2" Dia.	2165	2165	14420	F1, L27
PBS66R	Rough 6x6	12	14	6	5 ³ / ₈	6 ¹ / ₂	3 ¹¹ / ₁₆	14-16d	2 - 1/2" Dia.	2165	2165	14420	170

- For higher downloads, solid pack grout under 1" standoff plate before installing PBS into concrete. Base download on column or concrete, according to the code.
- Concrete shall have a minimum compressive strength, $f'_c = 2500$ psi.
- Multiply Seismic and Wind ASD load values by 1.4 or 1.6 respectively to obtain LRFD capacities.
- In accordance with IBC Section 1613.1, detached one- and two-family dwellings in Seismic Design Category (SDC) C may use "Wind and SDC A&B" allowable loads.
- Post bases do not provide adequate resistance to prevent members from rotating about the base and therefore are not recommended for non top-supported installations (such as fences or unbraced carports).
- Download shall be reduced where limited by the design capacity of the post.

- See pages 245-246 for common post allowable loads.
- Designer is responsible for concrete design.
- For lateral loads for all PBS models: F_1 allowable = 1165 lbs. when using nails and 230 lbs. when using bolts. F_2 allowable = 835 lbs. when using either nails or bolts.
- Structural composite lumber columns have sides that either show the wide face or the edges of the lumber strands/veneers known as the narrow face. Values in the tables reflect installation into the wide face. See Technical Bulletin T-C-SCLCLM for load reductions due to narrow face installations.
- NAILS:** 16d = 0.162" dia. x 3 1/2" long. See pages 22-23 for other nail sizes and information.

EPS4Z Post Bases

The EPS4Z provides a light-duty connector for attachment of posts to concrete.

MATERIAL: 14 gauge

FINISH: ZMAX® coating; see Corrosion Information, pages 13-15.

INSTALLATION: • Use all specified fasteners. See General Notes.

- Post bases do not provide adequate resistance to prevent members from rotating about the base and therefore are not recommended for non top-supported installations (such as fences or unbraced carports).
- Embed into wet concrete up to the embedment line. A 2" minimum side cover is required to obtain the full load.
- Posts shall be preservative-treated wood to meet building code requirements.

CODES: See page 12 for Code Reference Key Chart.

These products are available with additional corrosion protection. Additional products on this page may also be available with this option, check with Simpson Strong-Tie for details.

Model No.	Nails	Allowable Loads (DF/SP)		Code Ref.
		Non-Cracked Uplift	Cracked Uplift	
Wind and Seismic Design Category A & B				
EPS4Z	8-10dx1 1/2	980	685	I28, F1, L27
Seismic Design Category C-F				
EPS4Z	8-10dx1 1/2	825	575	I28, F1, L27

- Loads may not be increased for short-term loading.
- Concrete shall have a minimum compressive strength, $f'_c = 2500$ psi.
- Multiply Seismic and Wind ASD load values by 1.4 or 1.6 respectively to obtain LRFD capacities.
- In accordance with IBC Section 1613.1, detached one- and two-family dwellings in Seismic Design Category (SDC) C may use "Wind and SDC A&B" allowable loads.
- Download shall be reduced where limited by the design capacity of the post. See pages 245-246 for common post allowable loads.
- For lateral loads: F_1 allowable = 575 lbs. and F_2 allowable = 680 lbs.
- Designer is responsible for concrete design.
- Structural composite lumber columns have sides that either show the wide face or the edges of the lumber strands/veneers known as the narrow face. Values in the tables reflect installation into the wide face. See Technical Bulletin T-C-SCLCLM for load reductions due to narrow face installations.
- NAILS:** 10dx1 1/2 = 0.148" dia. x 1 1/2" long. See pages 22-23 for other nail sizes and information.

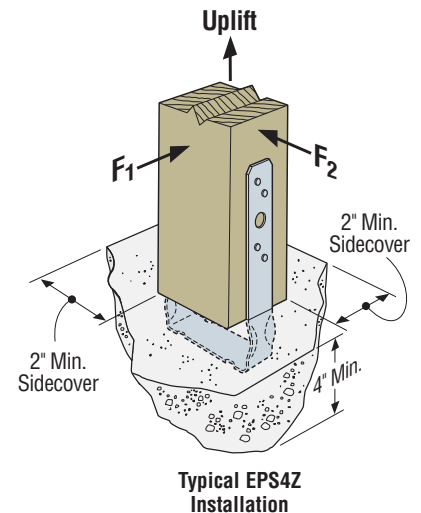
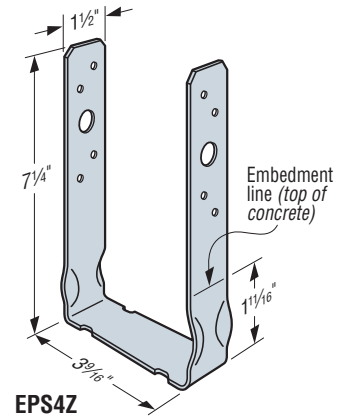

CBS/CBSQ Column Bases



This product is preferable to similar connectors because of a) easier installation, b) higher loads, c) lower installed cost, or a combination of these features.

The CBS column base installs with machine bolts and provides tested capacity. The 1" standoff (included) meets code requirements for structural posts installed in basements or exposed to weather or water splash. The CBSQ uses Simpson Strong-Tie® Strong-Drive® SDS Heavy-Duty Connector screws, which allow for fast installation, reduced reveal and high capacity, provides a greater net section area of the column compared to bolts.

MATERIAL: See table **FINISH:** Galvanized, available in HDG
INSTALLATION: • Use all specified fasteners.
See General Notes.

- For CBS, install with two machine bolts.
- For CBSQ, install 1/4"x2" Strong-Drive SDS Heavy-Duty Connector screws, which are provided with the column base. (Lag screws will not achieve the same load.)
- For full loads, a minimum of 3" side cover shall be provided.
- Post bases do not provide adequate resistance to prevent members from rotating about the base and therefore are not recommended for non top-supported installations (such as fences or unbraced carports).

ORDERING: To order the CBSQ with screws, specify CBSQ-SDS2. To order without screws, specify CBSQ.

CODES: See page 12 for Code Reference Key Chart.

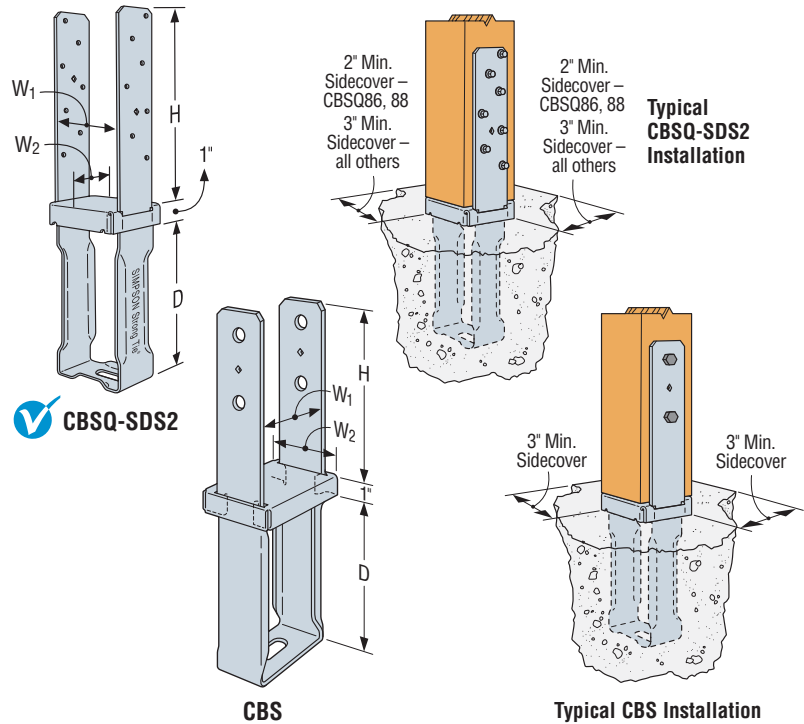

These products are available with additional corrosion protection. Additional products on this page may also be available with this option, check with Simpson Strong-Tie for details.

Model No.	Nominal Column Size	Material		Dimensions				Machine Bolts		Allowable Loads (DF/SP)			Code Ref.
		Base (Ga)	Strap (Ga x Width)	W ₁	W ₂	D	H	Qty.	Dia.	Non-Cracked Uplift	Cracked Uplift	Download	
Wind and Seismic Design Category A & B													
CBS44	4x4	12	10 ga x 2 1/4	3 1/16	3 1/2	7 1/8	8 3/8	2	5/8	5390	4845	10975	170
CBS46	4x6	12	10 ga x 3	3 1/16	5 1/16	7 13/16	8 11/16	2	5/8	5390	4845	14420	
CBS66	6x6	12	10 ga x 3	5 1/2	5 1/2	6 7/8	8 3/4	2	5/8	4555	3190	14420	
Seismic Design Category C-F													
CBS44	4x4	12	10 ga x 2 1/4	3 1/16	3 1/2	7 1/8	8 3/8	2	5/8	5390	4070	10975	170
CBS46	4x6	12	10 ga x 3	3 1/16	5 1/16	7 13/16	8 11/16	2	5/8	5390	4070	14420	
CBS66	6x6	12	10 ga x 3	5 1/2	5 1/2	6 7/8	8 3/4	2	5/8	3830	2680	14420	

See footnotes below.

Model No.	Nominal Column Size	Material		Dimensions				Simpson Strong-Tie SDS Screws	Allowable Loads DF/SP			Code Ref.
		Base (Ga)	Strap (Ga x Width)	W ₁	W ₂	D	H		Non-Cracked Uplift	Cracked Uplift	Download	
Wind and Seismic Design Category A & B												
CBSQ44-SDS2	4x4	12	10 ga x 2 1/4	3 1/16	3 1/2	7 1/8	8 3/8	14-SDS 1/4"x2"	5390	4845	10975	I28, F1, L27
CBSQ46-SDS2	4x6	12	10 ga x 3	3 1/16	5 1/16	7 13/16	8 11/16	14-SDS 1/4"x2"	5390	4845	14420	
CBSQ66-SDS2	6x6	12	10 ga x 3	5 1/2	5 1/2	6 7/8	8 3/4	14-SDS 1/4"x2"	4555	3190	14420	
CBSQ86-SDS2	6x8	12	7 ga x 3	7 1/2	5 3/8	6 1/8	8 11/16	12-SDS 1/4"x2"	3975	2780	20915	
CBSQ88-SDS2	8x8	12	7 ga x 3	7 1/2	7 7/8	6 1/8	8 11/16	12-SDS 1/4"x2"	3975	2780	22225	
Seismic Design Category C-F												
CBSQ44-SDS2	4x4	12	10 ga x 2 1/4	3 1/16	3 1/2	7 1/8	8 3/8	14-SDS 1/4"x2"	5390	4070	10975	I28, F1, L27
CBSQ46-SDS2	4x6	12	10 ga x 3	3 1/16	5 1/16	7 13/16	8 11/16	14-SDS 1/4"x2"	5390	4070	14420	
CBSQ66-SDS2	6x6	12	10 ga x 3	5 1/2	5 1/2	6 7/8	8 3/4	14-SDS 1/4"x2"	3830	2680	14420	
CBSQ86-SDS2	6x8	12	7 ga x 3	7 1/2	5 3/8	6 1/8	8 11/16	12-SDS 1/4"x2"	3340	2335	20915	
CBSQ88-SDS2	8x8	12	7 ga x 3	7 1/2	7 7/8	6 1/8	8 11/16	12-SDS 1/4"x2"	3340	2335	22225	

1. Loads may not be increased by short-term loading.
2. For higher downloads, solid pack grout under 1" standoff plate before installing CBS or CBSQ into concrete. Base download on column or concrete, according to the code.
3. Concrete shall have a minimum compressive strength, $f'_c = 2500$ psi.
4. Multiply Seismic and Wind ASD load values by 1.4 or 1.6 respectively to obtain LRFD capacities.
5. In accordance with IBC Section 1613.1, detached one- and two-family dwellings in

6. Download shall be reduced where limited by the design capacity of the column. See pages 245-246 for common post allowable loads.
7. Designer is responsible for concrete design.
8. Structural composite lumber columns have sides that either show the wide face or the edges of the lumber strands/veneers known as the narrow face. Values in the tables reflect installation into the wide face. See Technical Bulletin T-C-SCLCLM for load reductions due to narrow face installations.

LCB/CB Column Bases

MATERIAL: Strap: LCB—12 gauge; CB4x, CB5x, CB6x—7 gauge; CB7x and larger—3 gauge
Base: LCB—16 gauge; CB4x through CB9x—7 gauge; CB10x—3 gauge

FINISH: LCB, CB44, CB46, CB48, CB66, CB68, CB610—galvanized; all other CB—Simpson Strong-Tie® gray paint or HDG. Some models available in HDG or stainless steel

INSTALLATION: • Use all specified fasteners. See General Notes.

- For full loads, minimum side cover required is 3" for CB, 2" for LCB.
- Install all models with bottom of base plate flush with concrete.
- Post bases do not provide adequate resistance to prevent members from rotating about the base and therefore are not recommended for non top-supported installations (such as fences or unbraced carports).

OPTIONS:

- LCB and CB are available in rough size. Other sizes available for CB specify W₁ and W₂ dimensions. Consult Simpson Strong-Tie for bolt sizes and allowable loads.

CODES: See page 12 for Code Reference Key Chart.

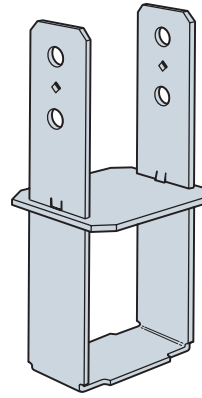

CB44
(CB46, CB48, CB64, CB66, CB68, CB86, CB88, CB610 similar)

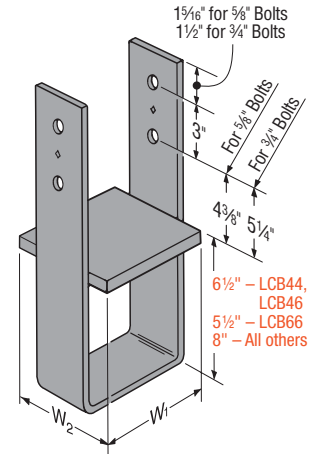

Configuration of all other CB sizes

These products are available with additional corrosion protection. Additional products on this page may also be available with this option, check with Simpson Strong-Tie for details.

Model No.	Nominal Column Size	Dimensions (in.)		Column Fasteners			Allowable Loads DF/SP/SPF/HF (160)				Code Ref.
		W ₁	W ₂	Nails	Machine Bolts		Wind and SDC A&B		SDC C-F		
					Qty.	Dia. (in.)	Non-Cracked Uplift	Cracked Uplift	Non-Cracked Uplift	Cracked Uplift	
LCB44	4x4	3 1/16	3 1/2	12-16d	2	1/2	1170	820	985	690	I28, F1, L27
CB44	4x4	3 1/16	3 1/16	NA	2	5/8	6710	4700	5640	3945	
LCB46	4x6	3 1/16	5 1/2	12-16d	2	1/2	1170	820	985	690	
CB46	4x6	3 1/16	5 1/2	NA	2	5/8	6710	4700	5640	3945	
CB48	4x8	3 1/16	7 1/2	NA	2	5/8	6710	4700	5640	3945	
CB5-4.5	GLULAM	4 1/2	5 1/8	NA	2	5/8	6710	4700	5640	3945	170
CB5-6	GLULAM	6	5 1/8	NA	2	5/8	6710	4700	5640	3945	
LCB66	6x6	5 1/2	5 1/2	12-16d	2	1/2	1170	820	985	690	I28, F1, L27
CB66	6x6	5 1/2	5 1/2	NA	2	5/8	6710	4700	5640	3945	
CB6-7	6x	5 1/2	7	NA	2	5/8	6710	4700	5640	3945	170
CB68	6x8	5 1/2	7 1/2	NA	2	5/8	6710	4700	5640	3945	
CB610	6x10	5 1/2	9 1/2	NA	2	5/8	6710	4700	5640	3945	I28, F1, L27
CB612	6x12	5 1/2	11 1/2	NA	2	5/8	6710	4700	5640	3945	
CB71/8 -4	PSL	7 1/8	3 1/2	NA	2	3/4	6710	4700	5640	3945	170
CB71/8 -6	PSL	7 1/8	5 1/2	NA	2	3/4	6710	4700	5640	3945	
CB71/8 -7	PSL	7 1/8	7	NA	2	3/4	6710	4700	5640	3945	
CB7-6	GLULAM	6	6 3/4	NA	2	3/4	6710	4700	5640	3945	
CB7-7.5	GLULAM	7 1/2	6 3/4	NA	2	3/4	6710	4700	5640	3945	
CB7-9	GLULAM	9	6 3/4	NA	2	3/4	6710	4700	5640	3945	
CB7-10.5	GLULAM	10 1/2	6 3/4	NA	2	3/4	6710	4700	5640	3945	
CB86	8x6	7 1/2	5 1/2	NA	2	3/4	6710	4700	5640	3945	
CB88	8x8	7 1/2	7 1/2	NA	2	3/4	6710	4700	5640	3945	
CB810	8x10	7 1/2	9 1/2	NA	2	3/4	6710	4700	5640	3945	
CB812	8x12	7 1/2	11 1/2	NA	2	3/4	6710	4700	5640	3945	
CB9-6	GLULAM	6	8 3/4	NA	2	3/4	6710	4700	5640	3945	
CB9-7.5	GLULAM	7 1/2	8 3/4	NA	2	3/4	6710	4700	5640	3945	
CB9-9	GLULAM	9	8 3/4	NA	2	3/4	6710	4700	5640	3945	
CB9-10.5	GLULAM	10 1/2	8 3/4	NA	2	3/4	6710	4700	5640	3945	
CB1010	10x10	9 1/2	9 1/2	NA	2	3/4	6710	4700	5640	3945	
CB1012	10x12	9 1/2	11 1/2	NA	2	3/4	6710	4700	5640	3945	
CB1212	12x12	11 1/2	11 1/2	NA	2	3/4	6710	4700	5640	3945	

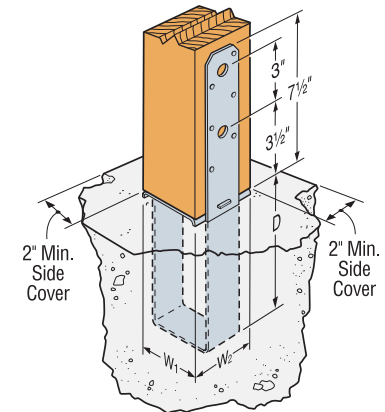

LCB

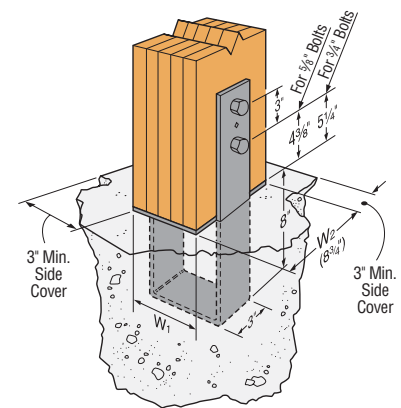

CB9
(CB5, CB7 similar) for Glulam Column

1. Loads may not be increased for short-term loading.
2. Concrete shall have a minimum compressive strength, f_c = 2500 psi.
3. LCB products may be installed with either bolts OR nails (not both) to achieve table loads.
4. Multiply Seismic and Wind ASD load values by 1.4 or 1.6 respectively to obtain LRFD capacities.
5. In accordance with IBC Section 1613.1, detached one- and two-family dwellings in Seismic Design Category (SDC) C may use "Wind and SDC A&B" allowable loads.
6. Download capacity shall be based on either the wood post design or concrete design calculated per code. See pages 245-246 for common post allowable loads.
7. Designer is responsible for concrete design. Minimum foundation dimensions are for anchorage only.
8. Loads must not be increased by short-term loading.
9. **NAILS:** 16d = 0.162" dia. x 3 1/2" long. See pages 22-23 for other nail sizes and information.

PPBZ Porch Post Base

The PPBZ porch base offers a simplified, one-time installation designed to support permanent porch framing throughout all stages of construction. This design eliminates the need for temporary vertical support and streamlines the subcontractor scheduling process while still providing adequate safety to enable full access for installers/inspectors.

The porch post base is fastened to the footing with two Simpson Strong-Tie® Titen® masonry screws when framing the porch roof. Then, when the time is right, the concrete contractor is able to complete the last phase of the porch slab without the interference of temporary vertical support and without the framer having to return to the jobsite after the slab has hardened. Designed to withstand vertical construction loads prior to embedment in concrete, the PPBZ will support the weight of most framed porches and overhangs.

FEATURES:

- Stiffened embedded side stirrups provide temporary vertical download support without being embedded into concrete
- 1" stand-off reduces the potential for decay at post or column ends
- Two available sizes provide both 4" and 6" slab thicknesses
- Pre-pour installation eliminates temporary support
- No disruption in scheduling
- Eliminates additional move-ins by trades and certain inspection call backs

MATERIAL: See table

FINISH: ZMAX® coating

INSTALLATION: • Use all specified fasteners. See General Notes.

- Locate and place PPBZ on footing according to framing plans
- Secure PPBZ to footing with 2 - (1/4" dia. x 1 1/4" long hex head) Titen® concrete screws located a minimum of 1 1/2" from the edge of concrete.
- Attach 4x4 post to PPBZ using 12-10d common (0.148" dia. x 3" long) nails. After bracing the top and bottom of the post from lateral movement, the post may then be loaded in download or uplift.
- When ready, pour concrete porch slab (4" or 6") up to the bottom of the stand-off base while maintaining minimum 1" concrete side coverage.

CODES: See page 12 for Code Reference Key Chart.

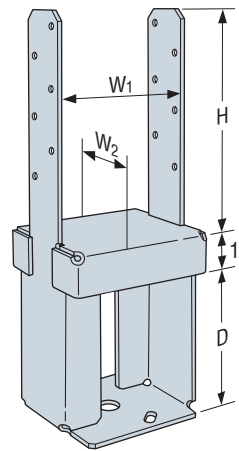

PPB44-4Z
(PPB44-6Z similar)

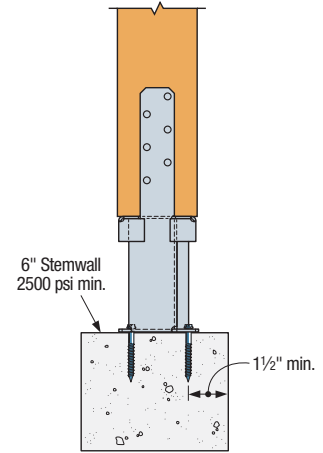

Typical PPB44-4Z Installation
(Before slab is poured)

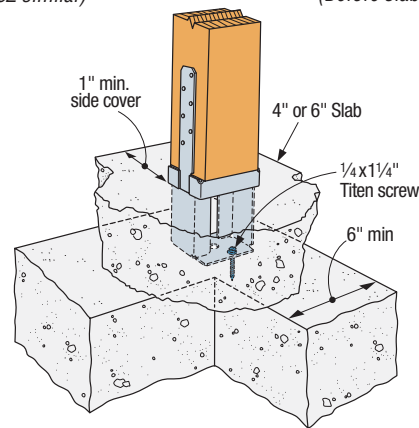

Typical PPB44-4Z Installation

These products are available with additional corrosion protection. Additional products on this page may also be available with this option, check with Simpson Strong-Tie for details.

Model No.	Nominal Post Size	Material		Dimensions (in.)				Fasteners		Allowable Loads (DF/SP/SPF/HF)					Code Ref.
		Base (Ga)	Strap (Ga x Width)	W ₁	W ₂	D	H	Foundation	Post	Prior to Pour		Embedded into Concrete			
										Uplift (160)	Down (100)	Uplift (160)		Down (100)	
Wind and Seismic Design Category A & B															
PPB44-4Z	4x4	12	12 ga x 1 1/2	3 5/8	3 3/16	4	5	2-1/4x1 1/4 Titen	12-10d	220	4720	1480	1035	7830	170
PPB44-6Z	4x4	12	12 ga x 1 1/2	3 5/8	3 3/16	6	5	2-1/4x1 1/4 Titen	12-10d	220	4295	2105	2105	10505	
Seismic Design Category C-F															
PPB44-4Z	4x4	12	12 ga x 1 1/2	3 5/8	3 3/16	4	5	2-1/4x1 1/4 Titen	12-10d	220	4720	1245	870	7830	170
PPB44-6Z	4x4	12	12 ga x 1 1/2	3 5/8	3 3/16	6	5	2-1/4x1 1/4 Titen	12-10d	220	4295	2105	1895	10505	

1. Loads may not be increased for short-term loading.
2. Concrete shall have a minimum compressive strength, $f'_c = 2500$ psi.
3. Multiply Seismic and Wind ASD load values by 1.4 or 1.6 respectively to obtain LRFD capacities.
4. In accordance with IBC Section 1613.1, detached one- and two- family dwellings in Seismic Design Category (SDC) C may use "Wind and SDC A&B" allowable loads.
5. Download shall be reduced where limited by the design capacity of the post. See pages 245-246 for common post allowable loads.
6. Designer is responsible for concrete design.
7. For full loads, nearest concrete edge required is 4" from PPBZ center line.
8. Structural composite lumber columns have sides that either show the wide face or the edges of the lumber strands/veneers known as the narrow face. Values in the tables reflect installation into the wide face. See Technical Bulletin T-C-SCLCLM for load reductions due to narrow face installations.
9. **NAILS:** 10d = 0.148" dia. x 3" long. See pages 22-23 for other nail sizes and information.

BC/BCS Post Caps

The BCS allows for the connection of 2-2x's to a 4x post or 3-2x's to a 6x post. Double shear nailing between beam and post gives added strength. The BC series offers dual purpose post cap/base for light cap or base connections.

MATERIAL: 18 gauge **FINISH:** Galvanized. Some products available in ZMAX® coating; see Corrosion Information, pages 13-15.

INSTALLATION: • Use all specified fasteners. See General Notes.

- Do not install bolts into pilot holes.
- BCS: install dome nails on beam; drive nails at an angle through the beam into the post below to achieve the table loads
- BC: install with 16d commons or 16dx2½" joist hanger nails.
- Post bases do not provide adequate resistance to prevent members from rotating about the base and therefore are not recommended for non top-supported installations (such as fences or unbraced carports).
- To tie multiple 2x members together, the Designer must determine the fasteners required to join members to act as one unit without splitting the wood.

CODES: See page 12 for Code Reference Key Chart.

These products are available with additional corrosion protection. Additional products on this page may also be available with this option, check with Simpson Strong-Tie for details.

These products are approved for installation with the Strong-Drive® SD Connector screw. See page 27 for more information.

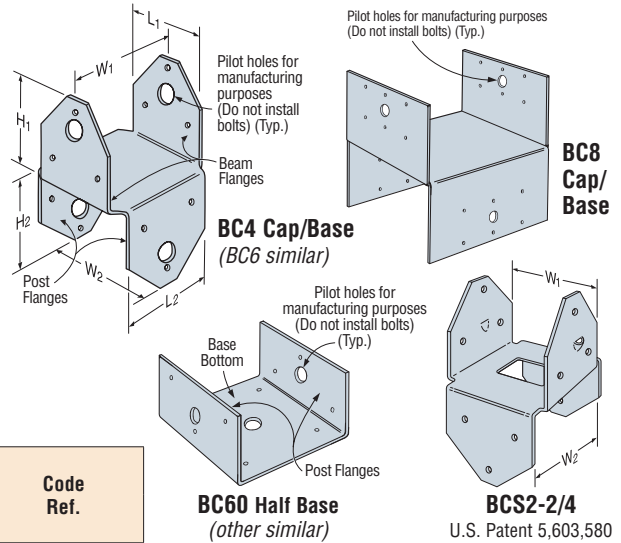

Model No.	Dimensions						Fasteners			Allowable Loads (DF/SP) (160) ¹		Code Ref.
	W ₁	W ₂	L ₁	L ₂	H ₁	H ₂	Beam Flange	Post Flange	Base Bottom	Uplift	Lateral	
CAPS												
BC4	3½	3½	2½	2½	3	3	6-16d	6-16d	—	980	1000	I12, I27, L4, L5, F11
BC46	3½	5½	4½	2½	3½	2½	12-16d	6-16d	—	980	1000	I12, L4, F11
BC4R	4	4	4	4	3	3	12-16d	12-16d	—	980	1000	
BC6	5½	5½	4½	4½	3½	3½	12-16d	12-16d	—	1050	2000	
BC6R	6	6	6	6	3	3	12-16d	12-16d	—	1050	2000	
BC8	7½	7½	7½	7½	4	4	12-16d	12-16d	—	1800	2000	I12, I27, L4, L5, F11
BCS2-2/4	3½	3½	2½	2½	2½	2½	8-10d	6-10d	—	780	1025	
BCS2-3/6	4½	5½	4½	2½	3½	2½	12-16d	6-16d	—	800	1495	
BASES												
BC40	3½	—	3¼	—	2¼	—	—	6-16d	4-16d	510	735	I27, L5
BC40R	4	—	4	—	3	—	—	6-16d	4-16d	510	735	170
BC460	5½	—	3½	—	3	—	—	6-16d	4-16d	450	735	I27, L5
BC60	5½	—	5½	—	3	—	—	6-16d	4-16d	450	735	
BC60R	6	—	6	—	3	—	—	6-16d	4-16d	450	735	
BC80	7½	—	7½	—	4	—	—	6-16d	4-16d	450	735	
BC80R	8	—	8	—	4	—	—	6-16d	4-16d	450	735	170

1. Allowable loads have been increased for wind or earthquake with no further increase allowed; reduce where other loads govern.
2. Structural composite lumber columns have sides that show either the wide face or the edges of the lumber strands/veneers. Values in the tables reflect installation into the wide face. See technical bulletin T-SCLCOLUMN for values on the narrow face (edge).
3. Base allowable loads assumes nails have full penetration into supporting member. Loads do not apply to end grain post installations.
4. **NAILS:** 16d = 0.162" dia. x 3½" long, 10d = 0.148" dia. x 3" long. See pages 22-23 for other nail sizes and information.

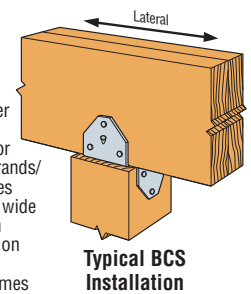

LCC Lally Column Caps / CCOS Steel Column Caps

Lally column caps and steel column caps provide adequate bearing length for larger girder reactions.

MATERIAL: LCC—12 gauge; CCOS—7 gauge **FINISH:** LCC—Simpson Strong-Tie® gray paint; CCOS—G90 Galvanized

INSTALLATION: • Use all specified fasteners. See General Notes.

- LCC—Fit the lally column cap over the lally column and attach to the girder.
- CCOS—Attach steel column cap to column end plate with (4) Simpson Strong-Tie Quik Drive® XQ112S1224 self-tapping screws (provided) and attach to girder. Install with ⅝" hex driver. See flier F-CCOS for additional CCOS applications.

CODES: See page 12 for Code Reference Key Chart.

Model No.	W	Girder	Nails ⁷	Lally Column Outside Diameter	Allowable Loads			Code Ref.		
					Download ^{1,2,3,4}				Uplift (160)	F ₁ ⁵ (160)
					DF/SP/SPF	LVL/PSL/LSL	(160)			
LCC4.5-3.5	4½	Triple 2x10/12	8-16d	3½	15820	—	—	1615		
CCOS3.12	3½	Double 2x10/12	10-10d	—	10200	—	1020	2200		
LCC3.5-3.5	3½	3.5 LVL/PSL/LSL	8-16d	3½	—	15820	—	1615		
LCC3.5-4	3½	3.5 LVL/PSL/LSL	8-16d	4	—	20670	—	1615		
CCOS3.62	3½	3.5 LVL/PSL/LSL	10-10d	—	—	16665	1020	2200		
LCC4.5-4	4½	Triple 2x10/12	8-16d	4	20670	—	—	1615		
CCOS4.62	4½	Triple 2x10/12	10-10d	—	15300	—	1020	2200		
LCC5.25-3.5	5½	5.25 LVL/PSL/LSL	8-16d	3½	—	15820	—	1615		
LCC5.25-4	5½	5.25 LVL/PSL/LSL	8-16d	4	—	20670	—	1615		
CCOS5.50	5½	5.25 LVL/PSL/LSL	10-10d	—	—	22100	1020	2200		
LCC6-3.5	6½	Quad 2x10/12	8-16d	3½	15820	—	—	1615		
LCC6-4	6½	Quad 2x10/12	8-16d	4	20670	—	—	1615		
LCC7-3.5	7½	7 LVL/PSL/LSL	8-16d	3½	—	15820	—	1615		
LCC7-4	7½	7 LVL/PSL/LSL	8-16d	4	—	20670	—	1615		
CCOS7.25	7½	7 LVL/PSL/LSL	10-10d	—	—	27525	1020	2200		

1. Loads may not be increased for short-term loading.
2. Allowable loads are determined using the lowest of the bearing loads using F_c per-p equal to 425 psi for SPF, 625 psi for DF and 700 psi for LVL/PSL/LSL.
3. Loads are for a continuous beam.
4. Spliced conditions for the LCC must be detailed by the Designer to transfer tension loads between spliced members by means other than the lally column. The splice condition load is 6750 lbs per beam side for LCC must be evenly loaded.
5. To achieve lateral loads, the LCC pipe must be welded to the

column with an ⅛" fillet weld around the entire pipe.

6. The CCOS must be attached to the column cap plate with (4) Quik Drive XQ112S1224 self-tapping screws through the end plate and into the bottom of the CCOS. Max column cap plate thickness = ½".
7. All pipe columns need to be designed by a qualified Designer. CCOS minimum column diameter is 3".
8. CCOS caps can resist out-of-plane (F₂) forces up to 2200 lbs. provided the beam is braced to resist torsional rotation.
9. **NAILS:** 16d = 0.162" dia. x 3½" long, 10d = 0.148" dia. x 3" long. See pages 22-23 for other nail sizes and information.

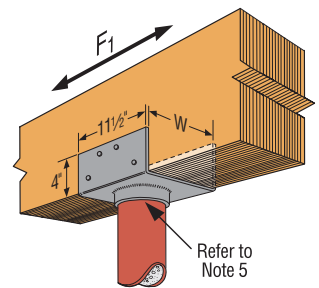

Typical LCC5.25-3.5 Installation connecting a 3-ply LVL and a 3½" diameter (O.D.) steel column

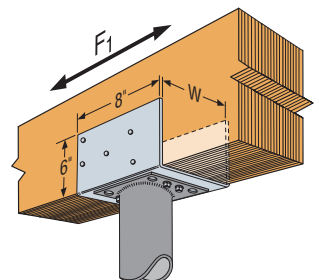

Typical CCOS5.50 Installation connecting a 3-ply LVL and a steel column

AC/ACE/LPCZ/LCE4/RTC Post Caps

The LCE4's universal design provides high capacity while eliminating the need for rights and lefts. For use with 4x or 6x lumber. LPCZ—Adjustable design allows greater connection versatility.
MATERIAL: LCE4—20 gauge; AC, ACE, LPC4Z—18 gauge; LPC6Z—16 gauge; RTC—14 gauge
FINISH: Galvanized. Some products available in ZMAX® coating and stainless steel; see Corrosion Information, pages 13-15.

INSTALLATION: • Use all specified fasteners. See General Notes.
• Install all models in pairs. LPCZ—2½" beams may be used if 10dx1½" nails are substituted for 10d commons.

CODES: See page 12 for Code Reference Key Chart.

These products are available with additional corrosion protection. Additional products on this page may also be available with this option, check with Simpson Strong-Tie for details.

These products are approved for installation with the Strong-Drive® SD Connector screw. See page 27 for more information.

Model No.	Dimensions		Total No. Fasteners		Allowable Loads (DF/SP) (160) ¹		Code Ref.
	W	L	Beam	Post	Uplift	Lateral	
AC4 (Min)	3¾"	6½"	8-16d	8-16d	1430	715	I12, I27, L4, L5, F11
AC4 (Max)	3¾"	6½"	14-16d	14-16d	2500	1070	
AC4RZ (Min)	4	7	8-16d	8-16d	1430	715	I12, L5, F11
AC4RZ (Max)	4	7	14-16d	14-16d	2500	1070	
ACE4 (Min)	—	4½"	6-16d	6-16d	1070	715	I12, L4, F11
ACE4 (Max)	—	4½"	10-16d	10-16d	1785	1070	
LCE4	—	5¾"	14-16d	10-16d	1905 ⁷	1425	IP1, L18, F25, 160
AC6 (Min)	5½"	8½"	8-16d	8-16d	1430	715	I12, I27, L4, L5, F11
AC6 (Max)	5½"	8½"	14-16d	14-16d	2500	1070	
AC6RZ (Min)	6	9	8-16d	8-16d	1430	715	I12, I27, L5, F11
AC6RZ (Max)	6	9	14-16d	14-16d	2500	1070	
ACE6 (Min)	—	6½"	6-16d	6-16d	1070	715	I12, L4, F11
ACE6 (Max)	—	6½"	10-16d	10-16d	1785	1070	
LPC4Z	3¾"	3½"	8-10d	8-10d	760	325	I12, I27, L4, L5, F11
LPC6Z	5¾"	5½"	8-10d	8-10d	915	490	I12, F11

- Allowable loads have been increased for wind or earthquake with no further increase allowed; reduce where other loads govern.
- Loads apply only when used in pairs.
- LPCZ lateral load is in the direction parallel to the beam.
- MIN nailing quantity and load values—fill all round holes; MAX nailing quantities and load values—fill round and triangle holes.
- Uplift loads do not apply to splice conditions.
- Spliced conditions must be detailed by the Designer to transfer tension loads between spliced members by means other than the post cap.
- LCE4 uplift load for mitered corner conditions is 985 lbs. (DF/SP) or 845 lbs. (SPF). Lateral loads do not apply.
- Structural composite lumber columns have sides that show either the wide face or the edges of the lumber strands/veneers. Values in the tables reflect installation into the wide face. See technical bulletin T-SCLCOLUMN for values on the narrow face (edge).
- NAILS:** 16d = 0.162" dia. x 3½" long, 10d = 0.148" dia. x 3" long. See pages 22-23 for other nail sizes and information.

Model No.	Dimensions (in.)		Total No. of Fasteners		DF/SP Uplift Loads		SPF Uplift Loads	
	W	L	Beam	Post	Total Uplift (160)	Total Uplift (160)	Total Uplift (160)	Total Uplift (160)
LCE4Z (Mitered Corner)	5¾"	5¾"	(14) 16d	(10) 16d	985	845		

- The allowable download for the mitered LCE4 connection is limited to bearing of the mitered section on the post and shall be determined by the Designer.
- Connectors must be installed in pairs to achieve listed loads.

Model No.	Dimensions (in.)		Total No. of Fasteners		DF/SP Uplift Loads			SPF Uplift Loads		
	W	L	Beam	Post	Side Beam	Main Beam	Total	Side Beam	Main Beam	Total
RTC44 ¹ (Mitered Corner)	3¾"	4¾"	(16) 16d	(10) 16d	900	900	1800	775	775	1550
RTC44 ² (Square Cut)	3¾"	4¾"	(16) 16d	(10) 16d	925	1230	1760	795	1060	1515

- The allowable download for the mitered RTC44 connection is limited to bearing of the mitered beams on the post and shall be determined by the Designer.
- The allowable download for the main beam in the square cut RTC44 connection is limited to bearing of the beam on the post and shall be determined by the Designer. The side beam allowable download is 1170 lbs.
- The combined uplift loads applied to all beams in the connector must not exceed the total allowable uplift load listed in the table.

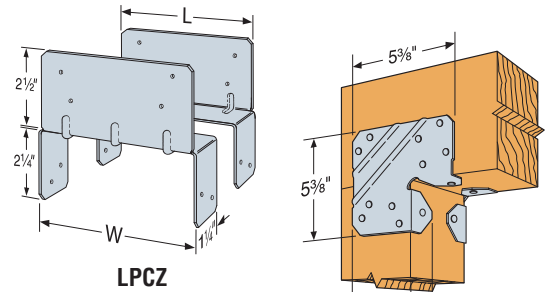

LPCZ

Typical LCE4 Installation (For 4x or 6x lumber)

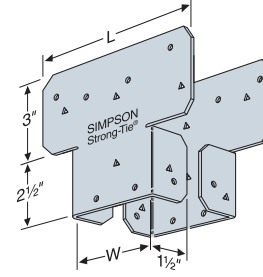

AC

Typical LCE4 Corner Installation (See note 7)

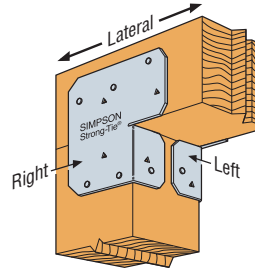

Typical ACE Installation

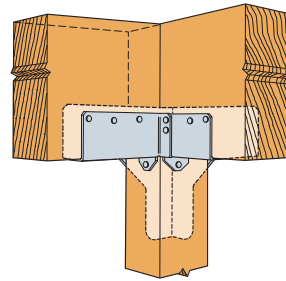

RTC44 Installation (Square Cut)

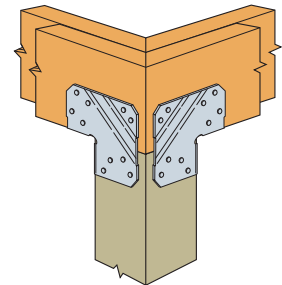

Typical LCE4Z Installation (Mitered Corner)

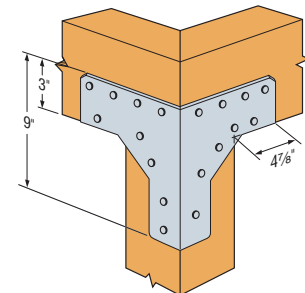

RTC44 Installation (Mitered Corner)

PCZ/EPCZ Post Caps

The next-generation PCZ/EPCZ post caps are designed with their post and beam flanges in-line so that one PCZ/EPCZ model can accommodate several post sizes. The PCZ/EPCZ now uses easier-to-install 10d common nails. An alternate choice of fasteners is Strong-Drive® #9x1½" SD Connector screws. ZMAX® finish is standard to meet exposure conditions in many environments. See additional corrosion information at www.strongtie.com/info.

MATERIAL: 16 gauge

FINISH: ZMAX coating

INSTALLATION:

- Use all specified fasteners; see General Notes.
- Do not install bolts into pilot holes.

OPTIONS:

- For end conditions, specify EPCZ post caps.
- For heavy-duty applications, see CCQ and CC Series.
- For retrofit applications, see AC and LC Series.

CODES: See page 12 for Code Reference Key Chart.

These products are available with additional corrosion protection. Additional products on this page may also be available with this option, check with Simpson Strong-Tie for details.

These products are approved for installation with the Strong-Drive® SD Connector screw. See page 27 for more information.

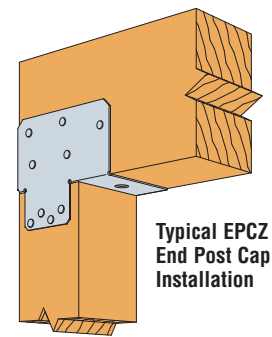
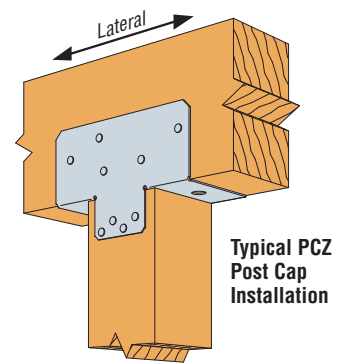
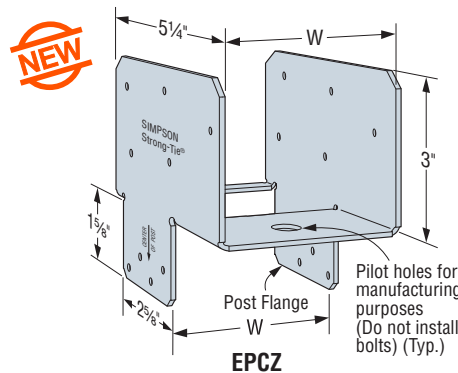
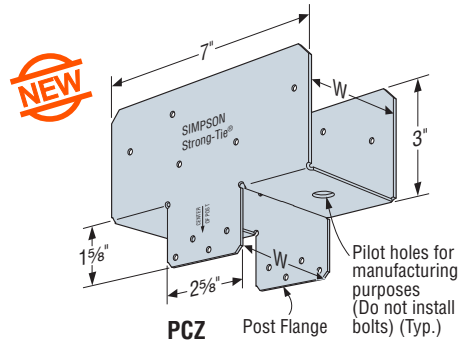

Model No. ⁷	W (in.)	Fasteners ^{5,6}		Post Size	Allowable Loads (DF/SP)				Code Ref.
		Beam	Post		PCZ		EPCZ		
					Uplift (160)	Lateral (160)	Uplift (160)	Lateral (160)	
PC4Z	3 5/8	10-10d	8-10d	2-2x4 ⁴	1480	1120	1130	895	160
				4x4	1480	1260	1130	1075	
				4x6	1480	1260	1130	1230	
				4x8	1480	1380	1130	1230	
PC6Z	5 1/2	10-10d	8-10d	4x6	1480	1260	1435	1075	
				6x6	1480	1295	1435	1230	
				6x8	1480	1380	1435	1230	
PC8Z	7 1/2	10-10d	8-10d	4x8	1480	1260	1435	1075	
				6x8	1480	1295	1435	1230	
				8x8	1480	1380	1435	1230	

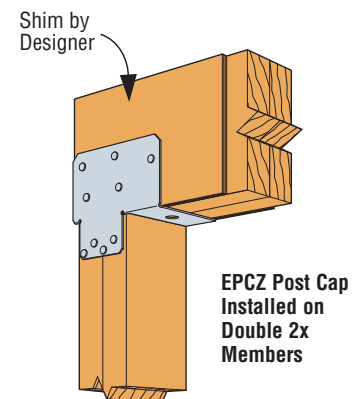
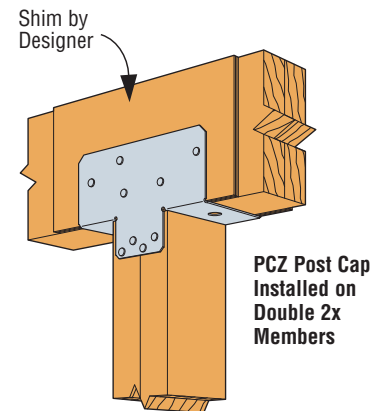

1. Allowable loads have increased for wind or earthquake with no further increase allowed; reduce where other loads govern.
2. Uplift loads do not apply to spliced conditions. Spliced conditions must be detailed by the Designer to transfer tension loads between spliced members by means other than the post cap.
3. Structural composite lumber columns have sides that show either the wide face or the edges of the lumber strands/veneers. Values in the tables reflect installation into the wide face and do not allow for installation into the narrow face.
4. Post and beam may consist of multiple members provided they are connected independently of the post cap fasteners.
5. 10d x 2½" (0.148" dia. x 2½" long) nails may be used with no load reduction for uplift and 0.85 of the table loads for lateral.
6. Strong-Drive® SD9x1½" Connector screws may be substituted for table fasteners with no load reduction.
7. Models available for rough size lumber, specify RZ suffix. Ex. PC4RZ
8. **NAILS:** 10d = 0.148" dia. x 3" long. See pages 22-23 for other nail sizes and information.
SCREWS: SD9112 = 0.131" dia. x 1½" long.

CCQ/ECCQ Column Caps



This product is preferable to similar connectors because of
a) easier installation, b) higher loads, c) lower installed cost,
or a combination of these features.

Column caps provide a high-capacity connection for column-beam combinations. This design uses Simpson Strong-Tie® Strong-Drive® SDS Heavy-Duty Connector screws to provide faster installation and provides a greater net section area of the column compared to bolts. The SDS screws provide for a lower profile compared to standard through bolts.

MATERIAL: CCQ3, ECCQ3, CCQ4, CCQ4.62, ECCQ4, ECCQ4.62, CCQ6, ECCQ6—7 gauge; all others—3 gauge

FINISH: Simpson Strong-Tie® gray paint, available in HDG;
CCQ and ECCQ—no coating

INSTALLATION:

- Install 1/4" x 2 1/2" Strong-Drive SDS Heavy-Duty Connector screws, which are provided with the column cap. (*Lag screws will not achieve the same load.*)
- CCQ and ECCQ column cap only (*no straps*) may be ordered for field-welding to pipe or other columns. Dimensions are same as CCQ and ECCQ.
- For rough cut lumber sizes, provide dimensions. An optional W₂ dimension may be specified with any column size given. (*Note that the W₂ dimension on straps rotated 90° is limited by the W₁ dimension.*)

OPTIONS:

- For end conditions, specify ECCQ.
- Straps may be rotated 90° where W₁ ≥ W₂ and for CCQ5-6.

CODES: See page 12 for Code Reference Key Chart.

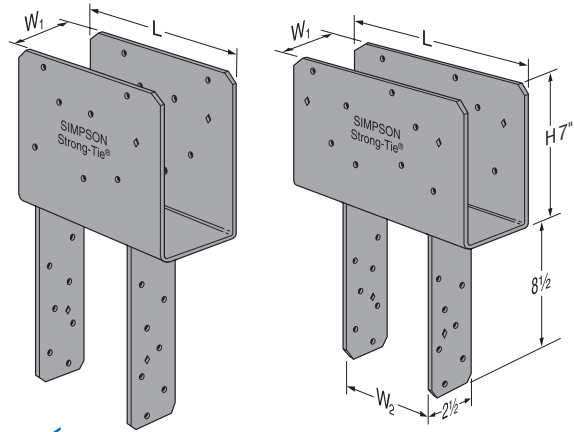

ECCQ46SDS2.5

CCQ46SDS2.5

Optional CCQ with straps rotated 90°

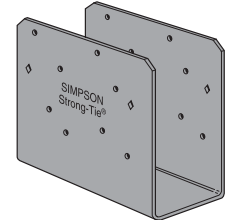
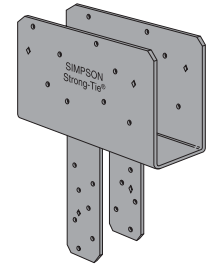

CCQ4-SDS2.5

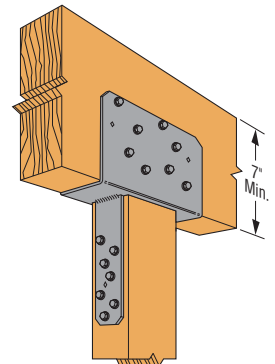

Typical CCQ46SDS2.5 Installation

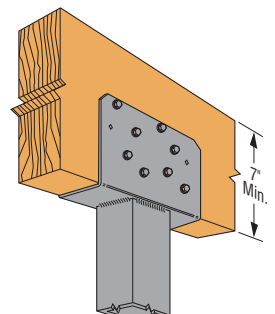

CCQ Installation on Steel Column

These products are available with additional corrosion protection. Additional products on this page may also be available with this option, check with Simpson Strong-Tie for details.

Model No.	Beam Width	Dimensions					No. of 1/4"x2 1/2" SDS Screws		Allowable Loads (DF/SP)				Code Ref.	CCQ/ECCQ Model No. (No Legs)
		W ₁	W ₂	L		H	Beam	Post	CCQ		ECCQ			
				CCQ	ECCQ				Uplift (160)	Down (100)	Uplift (160)	Down (100)		
CCQ3-4SDS2.5	3 1/8	3 3/4	3 3/8	11	8 1/2	7	16	14	5680	16980	3695	6125	I12, L4, F11	CCQ03-SDS2.5 ECCQ03-SDS2.5
CCQ3-6SDS2.5	3 1/8	3 3/4	5 1/2	11	8 1/2	7	16	14	5680	19250	3695	9625		
CCQ44SDS2.5	4x	3 3/8	3 3/8	11	8 1/2	7	16	14	5680	19020	4040	7655		
CCQ46SDS2.5	4x	3 3/8	5 1/2	11	8 1/2	7	16	14	7145	24065	4040	12030	170	CCQ04-SDS2.5 ECCQ04-SDS2.5
CCQ48SDS2.5	4x	3 3/8	7 1/2	11	8 1/2	7	16	14	7145	24065	4040	16405		
CCQ4.62-3.62SDS	4 1/2	4 3/8	3 3/8	11	8 1/2	7	16	14	5680	19020	4040	7655		
CCQ4.62-4.62SDS	4 1/2	4 3/8	4 3/8	11	8 1/2	7	16	14	5680	24450	4040	9845	170	CCQ04.62-SDS2.5 ECCQ04.62-SDS2.5
CCQ4.62-5.50SDS	4 1/2	4 3/8	5 1/2	11	8 1/2	7	16	14	7145	28585	4040	12030		
CCQ5-4SDS2.5	5 1/8	5 1/4	3 3/8	11	8 1/2	7	16	14	5680	26635	4040	10045		
CCQ5-6SDS2.5	5 1/8	5 1/4	5 1/2	11	8 1/2	7	16	14	7245	28190	5535	15785	I12, L4, F11	CCQ05-SDS2.5 ECCQ05-SDS2.5
CCQ5-8SDS2.5	5 1/8	5 1/4	7 1/2	11	8 1/2	7	16	14	7245	31570	5535	21525		
CCQ64SDS2.5	6x	5 1/2	3 3/8	11	8 1/2	7	16	14	5680	28585	4040	12030		
CCQ66SDS2.5	6x	5 1/2	5 1/2	11	8 1/2	7	16	14	7145	30250	4040	18905	160	CCQ06-SDS2.5 ECCQ06-SDS2.5
CCQ68SDS2.5	6x	5 1/2	7 1/2	11	8 1/2	7	16	14	7145	37815	4040	25780		
CCQ6-7.13SDS2.5	6x	5 1/2	7 1/2	11	8 1/2	7	16	14	7145	37815	4040	24490		
CCQ74SDS2.5	6 3/4	6 3/8	3 3/8	11	8 1/2	7	16	14	5680	33490	4040	13230	I12, L4, F11	CCQ07.12-SDS2.5 ECCQ07.12-SDS2.5
CCQ76SDS2.5	6 3/4	6 3/8	5 1/2	11	8 1/2	7	16	14	7245	37125	5535	20790		
CCQ77SDS2.5	6 3/4	6 3/8	6 3/8	11	8 1/2	7	16	14	7245	41580	5535	25515		
CCQ78SDS2.5	6 3/4	6 3/8	7 1/2	11	8 1/2	7	16	14	7245	41580	5535	28350	160	CCQ07.12-SDS2.5 ECCQ07.12-SDS2.5
CCQ7.1-4SDS2.5	7	7 1/8	3 3/8	11	8 1/2	7	16	14	5680	34730	4040	18375		
CCQ7.1-6SDS2.5	7	7 1/8	5 1/2	11	8 1/2	7	16	14	7245	38500	5535	28875		
CCQ7.1-7.1SDS2.5	7	7 1/8	7 1/2	11	8 1/2	7	16	14	7245	57750	5535	36750	160	CCQ08-SDS2.5 ECCQ08-SDS2.5
CCQ7.1-8SDS2.5	7	7 1/8	7 1/2	11	8 1/2	7	16	14	7245	52500	5535	39375		
CCQ86SDS2.5	8x	7 1/2	5 1/2	11	8 1/2	7	16	14	7245	41250	5535	25780		
CCQ88SDS2.5	8x	7 1/2	7 1/2	11	8 1/2	7	16	14	7245	51565	5535	35155	160	CCQ09-SDS2.5 ECCQ09-SDS2.5
CCQ96SDS2.5	8 3/4	8 3/8	5 1/2	11	8 1/2	7	16	14	7245	48125	5535	26950		
CCQ98SDS2.5	8 3/4	8 3/8	7 1/2	11	8 1/2	7	16	14	7245	53900	5535	36750		
CCQ106SDS2.5	10x	9 1/2	5 1/2	11	8 1/2	7	16	14	7245	52250	5535	32655		CCQ10-SDS2.5 ECCQ10-SDS2.5

1. Uplift loads have been increased for wind or earthquake with no further increase allowed; reduce where other loads govern.
2. Down loads may not be increased for short-term loading and shall not exceed the post capacity. See pages 245-246 for common post allowable loads.
3. Uplift loads do not apply to splice conditions.
4. Spliced conditions must be detailed by the Designer to transfer tension loads between spliced members by means other than the column cap.
5. Column sides are assumed to lie in the same vertical plane as the beam sides. CCQ4.62 models assume a minimum 3 1/2" wide post.
6. Structural composite lumber columns have sides that show either the wide face or the edges of the lumber strands/veneers. Values in the tables reflect installation into the wide face. See technical bulletin T-SCLC COLUMN for values on the narrow face (edge).
7. ECCQ uses 14 Strong-Drive® SDS Heavy-Duty Connector screws into the beam and 14 Strong-Drive SDS Heavy-Duty Connector screws into the post.
8. Beam depth must be a minimum 7".
9. For 5 1/4" engineered lumber, use 5 1/2" models.
10. CCQ and ECCQ welded to steel column will achieve same load as CCQ and ECCQ. Steel column width shall not be less than beam width. Weld by Designer.

CC/ECC/ECCU Column Caps

Column caps provide a high-capacity connection for column-beam combinations.
MATERIAL: CC3¼, CC44, CC46, CC48, CC4.62, CC64, CC66, CC68, CC6-7½, ECC3¼, ECC44, ECC46, ECC48, ECC4.62, ECC64, ECC66, ECC68, ECC6-7½—7 gauge; all others—3 gauge

FINISH: Simpson Strong-Tie® gray paint; may be ordered HDG; CCO, ECCO—no coating
INSTALLATION: • Use all specified fasteners. See General Notes.

- Bolt holes shall be a minimum of ½" to a maximum of ¼" larger than the bolt diameter (per 2005 NDS, section 11.1.2).
- Contact engineered wood manufacturers for connections that are not through the wide face.

OPTIONS: • Straps may be rotated 90° where $W_1 \geq W_2$ (see illustration) and for CC5¼-6.

- For special, custom, or rough cut lumber sizes, provide dimensions. An optional W_2 dimension may be specified. (The W_2 dimension on straps rotated 90° is limited by the W_1 dimension.)

• **CCO/ECCO**—Column cap only (no straps) may be ordered for field-welding to pipe or other columns. CCO/ECCO dimensions are the same as CC/ECC.

• **CCOB**—Any two CCOs may be specified for back-to-back welding to create a cross beam connector. Use the table loads; the load is no greater than the lesser element employed.

CODES: See page 12 for Code Reference Key Chart.

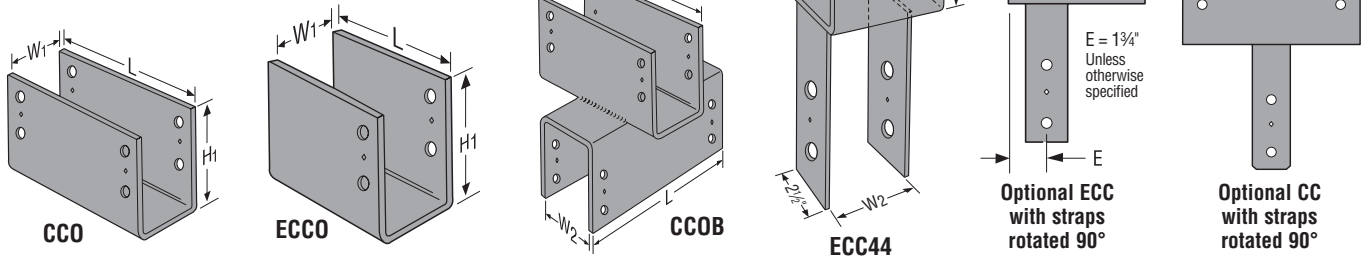

These products are available with additional corrosion protection. Additional products on this page may also be available with this option, check with Simpson Strong-Tie for details.

Model No. (CC shown ECC/ECCU similar)	Beam Width	Dimensions						Machine Bolts				Allowable Loads (DF/SP)				Code Ref.	CCO Model No. (No Legs)	ECCO Model No. (No Legs)	
		W ₁	W ₂	L			H ₁	Size	Beam			Down		Uplift					
				CC	ECC	ECCU			CC	ECC	ECCU	CC	ECC/ECCU	CC (160)	ECCU (160)				
CC3¼-4	3½	3¼	3½	11	7½	9½	6½	¾	4	2	4	2	16980	6125	3640	1010	I12, L4, F11	CC03¼	ECC03¼
CC3¼-6	3½	3¼	5½	11	7½	9½	6½	¾	4	2	4	2	19250	9625	3640	1010		CC04	ECC04
CC44	4x	3½	3½	7	5½	6½	4	¾	2	1	2	2	15310	7655	1465	205		CC04/6	ECC04/6
CC46	4x	3½	5½	11	8½	9½	6½	¾	4	2	4	2	24060	12030	2800	740	160	CC04/6	ECC04/6
CC48	4x	3½	7½	11	8½	9½	6½	¾	4	2	4	2	24060	16405	2800	740		CC04.62	ECC04.62
CC4.62-3.62	4½	4½	3½	11	8½	9½	6½	¾	4	2	4	2	19020	7655	2800	740		CC04.62	ECC04.62
CC4.62-4.62	4½	4½	4½	11	8½	9½	6½	¾	4	2	4	2	24450	9845	2800	740	CC04.62	ECC04.62	
CC4.62-5.50	4½	4½	5½	11	8½	9½	6½	¾	4	2	4	2	28585	12030	2800	740	CC04.62	ECC04.62	
CC5¼-4	5½	5¼	3½	13	9½	10½	8	¾	4	2	4	2	26635	10045	7530	2735	I12, L4, F11	CC05¼	ECC05¼
CC5¼-6	5½	5¼	5½	13	9½	10½	8	¾	4	2	4	2	28190	15785	7530	2735		CC05¼	ECC05¼
CC5¼-8	5½	5¼	7½	13	9½	10½	8	¾	4	2	4	2	37310	21525	7530	2735		CC06	ECC06
CC64	6x	5½	3½	11	7½	9½	6½	¾	4	2	4	2	28586	12030	4040	1165	160	CC06	ECC06
CC66	6x	5½	5½	11	7½	9½	6½	¾	4	2	4	2	30250	18905	4040	1165		CC06	ECC068
CC68	6x	5½	7½	11	9½	9½	6½	¾	4	2	4	2	37810	25780	4040	1165		CC07	ECC07
CC6-7½	6x	5½	7½	11	9½	9½	6½	¾	4	2	4	2	37810	24060	4040	1165	170	CC07	ECC07
CC74	6¾	6¾	3½	13	10½	10½	8	¾	4	2	4	2	33490	13230	7525	3605		CC07	ECC07
CC76	6¾	6¾	5½	13	10½	10½	8	¾	4	2	4	2	37125	20790	7525	3605		CC07½	ECC07½
CC77	6¾	6¾	6¾	13	10½	10½	8	¾	4	2	4	2	49140	25515	7525	3605	I12, L4, F11	CC07½	ECC07½
CC78	6¾	6¾	7½	13	10½	10½	8	¾	4	2	4	2	49140	28350	7525	3605		CC07½	ECC07½
CC7½-4	7	7½	3½	13	10½	10½	8	¾	4	2	4	2	34736	18375	7510	4855		160	CC07½
CC7½-6	7	7½	5½	13	10½	10½	8	¾	4	2	4	2	58500	28875	7585	4855	CC08		ECC08
CC7½-7½	7	7½	7½	13	10½	10½	8	¾	4	2	4	2	57750	36750	7585	4855	CC08		ECC08
CC7½-8	7	7½	7½	13	10½	10½	8	¾	4	2	4	2	52500	36750	7585	4855	I12, L4, F11	CC08	ECC08
CC84	8x	7¼	3½	13	10½	10½	8	¾	4	2	4	2	37210	16405	7440	2625		CC08	ECC08
CC86	8x	7¼	5½	13	10½	10½	8	¾	4	2	4	2	41250	23100	7440	2625		CC09	ECC09
CC88	8x	7¼	7½	13	10½	10½	8	¾	4	2	4	2	54600	31500	7440	2625	I12, L4, F11	CC09	ECC09
CC94	8¾	8¾	3½	13	10½	10½	8	¾	4	4	4	2	43410	19905	7515	3990		CC09	ECC09
CC96	8¾	8¾	5½	13	10½	10½	8	¾	4	4	4	2	48125	26950	7515	4670		CC10	ECC10
CC98	8¾	8¾	7½	13	10½	10½	8	¾	4	4	4	2	63700	36750	7515	4670	CC10	ECC10	
CC106	10x	9½	5½	13	10½	10½	8	¾	4	4	4	2	52250	29260	7515	3325	CC10	ECC10	

- Uplift loads have been increased for wind or earthquake with no further increase allowed; reduce where other loads govern.
- Down loads may not be increased for short-term loading and shall not exceed the post capacity. See pages 245-246 for common post allowable loads.
- CC uplift loads do not apply to splice conditions.
- Splice conditions with CCs must be detailed by the Designer to transfer tension loads between spliced members by means other than the column cap.
- Column sides are assumed to lie in the same vertical plane as the beam sides. CC4.62 models assume a minimum 3½" wide post.
- Structural composite lumber columns have sides that show either the wide face or the edges of the lumber strands/veneers. Values in the tables reflect installation into the wide face. See technical bulletin T-SCLCOLUMN for values on the narrow face (edge).
- Beam depth must be at least as tall as H₁.
- For 5¼" engineered lumber, use 5½" models.
- CCO and ECCO welded to steel column will achieve same load as CC and ECC. Steel column width shall not be less than beam width. Weld by Designer.

ECCLQ/CCCQ/CCTQ Column Caps

The ECCLQ, CCCQ and CCTQ column caps provide high-capacity, multiple beam-to-column connector options. The design uses Simpson Strong-Tie® Strong-Drive® SDS Heavy-Duty Connector screws to provide faster installation and a lower profile compared to standard through bolts. Screws are configured to provide high uplift design values.

MATERIAL: 7 gauge

FINISH: Simpson Strong-Tie® gray paint, also available in HDG

INSTALLATION:

- Install 1/4" x 2 1/2" Strong-Drive SDS Heavy-Duty Connector screws, which are provided, in all round holes. (*Lag screws will not achieve the same load.*)
- No additional welding is allowed.

OPTIONS:

- Many combinations of beam and post sizes can be manufactured (refer to worksheet T-CCQLTC-WS).
- Available in widths up to 8" wide.
- ECCLQ is available in left or right side beam orientations. Specify ECCLQ or ECCLRQ.
- Straps may be rotated where $W_1 > W_2$.
- Column caps may be ordered without the column straps for field welding to a column. No loads apply. Specify CCCOQ/CCTOQ/ECCLQ.

ORDERING:

- The L dimension varies depending on the width of the side stirrup (W_3 or W_4). Contact Simpson Strong-Tie for exact dimensions.
- Main beam stirrup height (H_1) is 7". Side beam stirrups (H_2 or H_3) can vary in height with the minimum height of 7". Specify the side stirrup height from the top of the cap.
- Example Order: 4x Main Beam, 6x Post, 4x Side Beam (*oriented to the left*) is ordered as an ECCLQ464SDS

CODES: See page 12 for Code Reference Key Chart.

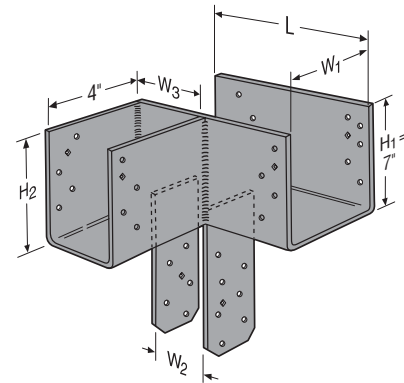

ECCLQ-SDS2.5

(Left direction shown)

Order ECCLRQ-SDS2.5 for right direction

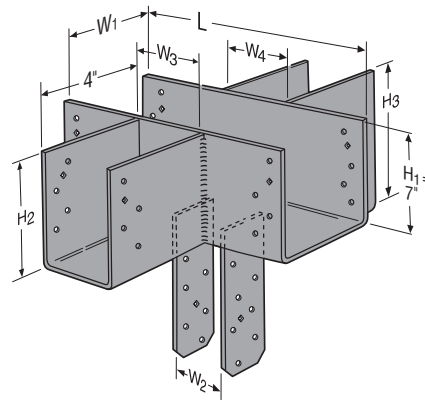

CCCQ-SDS2.5

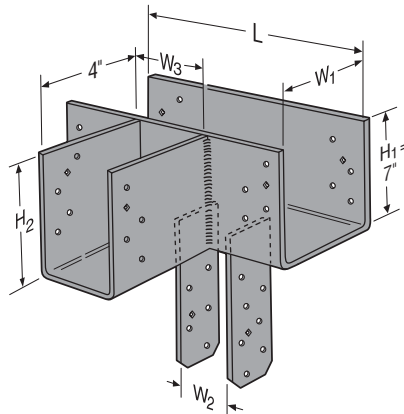

CCTQ-SDS2.5

Series	Allowable Loads (DF/SP)					Code Ref.
	Uplift (160)			Download (100)		
	Main Beam	Side Beam	Total ³	Side Beam	Total	
ECCLQ-SDS2.5	2835	1840	3795	6780	Refer to note #5	F24
CCCQ-SDS2.5	4780	2390 ²	4780	7000		
CCTQ-SDS2.5	4910	2350	5315	7000		

1. Uplift loads have been increased for wind or seismic; reduce where other loads govern. Downloads may not be increased.
2. Allowable load is per seat. Side beams must be loaded symmetrically for the CCCQ.
3. The combined uplift loads applied to all beams in the connector must not exceed the total allowable uplift load listed in the table.
4. The ECCLQ side beam may use a side beam uplift load up to 2350 lbs. The deflection of this load may exceed the standard 1/8" deflection by an additional 1/8".
5. The combined download for all of the carried beams shall not exceed the allowable download for the unmodified product on page 68 (*CCQ load for CCCQ and CCTQ, or ECCQ load for ECCLQ*). The download for each side beam shall not exceed the lesser of 35% of the allowable download or 9265 lbs. for the unmodified product.
6. The download to each side beam shall not exceed the allowable load shown, nor 35% of the allowable load for the unmodified product, whichever is lower.
7. Column width in the direction of the beam width must be the same as the main beam width (W_1).

ECCL/CCC/CCT Column Caps

Column-to-beam connections often have multiple beams framing on top of a column. L, T, and cross-column caps provide design solutions for this application. Many combinations of beam and post sizes can be manufactured (refer to worksheet T-CCLTC-WS for details) with the following criteria applied:

- The download capacity shall be determined from the capacity for the unmodified product (see page 69). The side beam can take a maximum of 40% of the download and shall not exceed 10,665 lbs. The sum of the loads for the side beam(s) and main beam can not exceed the table load.
- Uplift loads do not apply for ECCL caps. For CCC and CCT, uplift loads from table apply for main beam only.
- The column width in the direction of the main beam width must be the same as the main beam width (W_1).
- Specify the stirrup height from the top of the cap. The minimum side stirrup heights (H_2 or H_3) is $6\frac{1}{2}$ " ($3\frac{1}{2}$ " for 44s).
- The L dimension may vary depending on the width of the side stirrup (W_3 or W_4).
- Column caps may be ordered without the column straps for field welding to a column. No loads apply. Specify CCOC/CCOT/ECCOL.

Ordering Examples:

- A CCC66 with $W_3 = 5\frac{1}{2}$ ", H_2 and $H_3 = 6\frac{1}{2}$ " is a CC66 column cap with $5\frac{1}{2}$ " beams on each side with all beam seats flush.
- An ECCLR66 with $W_3 = 3\frac{3}{8}$ ", $H_2 = 7\frac{1}{2}$ " is an ECC66 end column cap with a 4x beam on the right side (specify direction left (which is shown) or right for stirrup) and stirrup seat 1" below the cap seat.

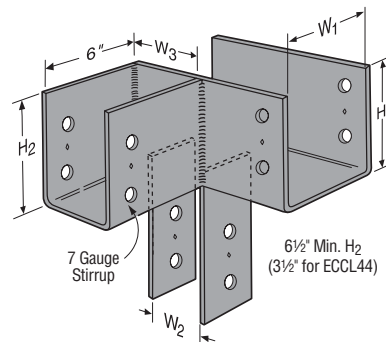

ECCL

(Left direction shown)
Order ECCLR for right direction

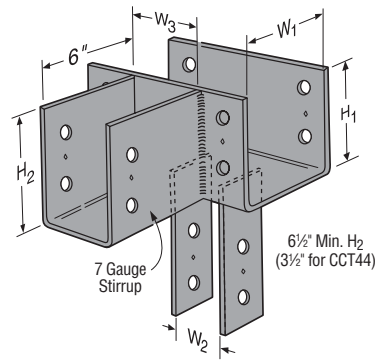

CCT

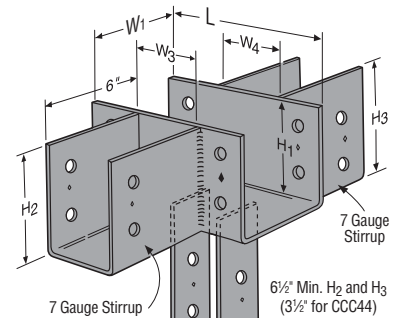

CCC

There are cost-effective alternatives for replacing column caps by using a combination of connectors. Designer must specify the options required.

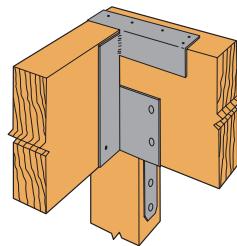

ECC and HW
(Top Flange Offset Right)

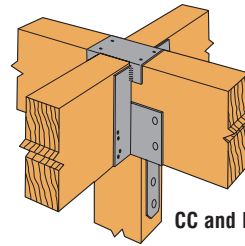

CC and HWD

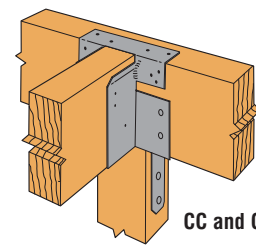

CC and GLT

Ordering Multiple-Beam Column Caps

Ordering bolted column caps incorporate several key steps that are important to ensure the highest-capacity capacity solution for your project. Here are some common steps to begin that process. For more information, refer to worksheet T-CCLTC-WS for bolted connections and worksheet T-CCQLTC for Quick Install connections. See page 2 of these worksheets for model numbers for common post and beam width combinations. These worksheets are available at www.strongtie.com.

- Choose Column Cap Style.** Look at the configuration of the column caps to determine which style column cap you require. If you don't know which style column cap is required, refer to your plans to determine the correct configuration.
- Determine Column Cap Dimensions.** Fill in the dimensions of the column cap on the worksheet. If you don't know the dimensions of the column cap, go directly to the "Post and Beam Dimensions" section.
- Provide Beam and Post Dimensions.** The "Post and Beam Dimensions" section of this worksheet is required. Fill in all applicable dimensions in actual inches, not as nominal dimensions.
- Determine Beam Orientation.** Refer to your plans or check the configuration of the column cap you selected in order to determine the orientation of the beam. Check the box for the beam orientation that best describes your beam configuration: Beam B flush at bottom of Beam A; Beam B flush at both the top and bottom of Beam A; or Beam B flush at top of Beam A.
- Check the box for the required style and strap orientation.
- Select Finish.** Standard finish is Simpson Strong-Tie® gray paint, available in HDG (specify HDG).
- Place Order.** Contact Simpson Strong-Tie for ordering information.

Innovative Solutions



No Company Understands Light-Frame Lateral Systems Better Than Simpson Strong-Tie

That's not bragging. It's the results of thousands of hours of research, development and testing that we put into our products as we consider nearly every application scenario. That knowledge, coupled with our out-in-the-field expertise, ensures that we clearly understand the requirements – and the expectations – of consistently delivering code-listed, cost-effective moment frames, shearwalls and multi-story uplift/overturning restraint solutions.

Strong Frame® Moment Frames

When lateral-force resistance is needed for structures with large openings and small wall spaces, Simpson Strong-Tie offers hundreds of Strong Frame moment frame configuration options. By using our latest Strong Frame catalog or Strong Frame Selector software, Designers can pick the configuration that best resists wind or seismic lateral loads for applications, such as soft-story retrofit wood structures or buildings built over tuck-under parking. Designing a multi-bay, multi-story project? We have loading sheets that you can fill out online by visiting www.strongtie.com.



Strong-Wall® Shearwalls

Our factory-built shearwalls maintain the industry's highest-quality standards and answer code requirements for ICC, City of Los Angeles and the State of Florida. Our Steel and Wood Strong-Wall panels as well as our field-trimmable Strong-Wall SB shearwall provide Designers and contractors with the ultimate in design flexibility for standard or custom applications.

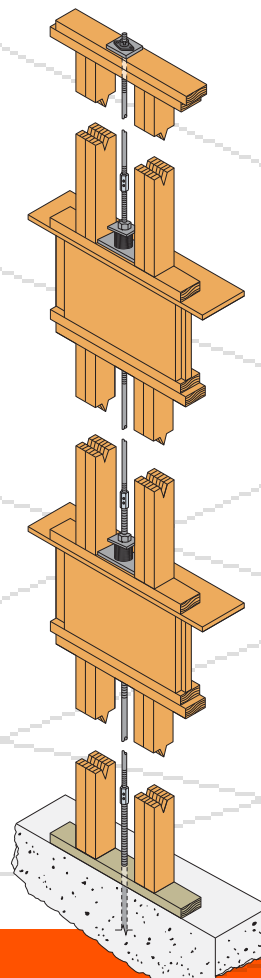

Strong-Rod® Shearwall Overturning and Roof Uplift Restraint Systems

For mid-rise wood construction projects, Simpson Strong-Tie provides the broadest line of continuous rod tie-down system components. With our unmatched experience testing multi-story building performance, no one understands how to resist shearwall overturning and roof uplift restraint better than Simpson Strong-Tie.

FACE MOUNT HANGERS LUC/LU/U/HU/HUC *Standard Joist Hangers*

Solid Sawn Joist Hangers

LUCZ concealed flange hanger available for 2x6, 2x8, 2x10 and 2x12 lumber. Ideal for end of ledger/ header or post conditions, the LUCZ also provides cleaner lines for exposed conditions such as overhead decks.

See Hanger tables on pages 76-83. See Hanger Options on pages 233-243 for hanger modifications, which may result in reduced loads.

LU—Value engineered for strength and economy. Precision-formed—engineered for installation ease and design value.

U—The standard U hanger provides flexibility of joist to header installation. Versatile fastener selection with tested allowable loads.

HU/HUC—Most models have triangle and round holes. To achieve maximum loads, fill both round and triangle holes with common nails. These heavy-duty connectors are designed for schools and other structures requiring additional strength, longevity and safety factors.

MATERIAL: See tables on pages 76-83.

FINISH: Galvanized. Some products available in ZMAX® coating.

INSTALLATION:

- Use all specified fasteners. See General Notes.
- HU/HUC—Can be installed filling round holes only, or filling round and triangle holes for maximum values.
- Joists sloped up to 1/4:12 achieve table loads.
- For installations to masonry or concrete see page 173.
- HU/HUC hangers can be welded to a steel member. Allowable loads are the lesser of the values in the Hanger tables on pages 76-83 or the weld capacity – refer to technical bulletin T-HUHUC-W.

OPTIONS: • HU is available with one flange concealed when the W dimension is less than 2 5/16" at 100% of the table load. Order HUC_X hanger.

Sloped, Skewed and Sloped/Skewed

- For low-cost, code-listed 45° skewes, see SUR/SUL and HSUR/HSUL. See also LSU/LSSU connectors.
- U/HU may be skewed to a maximum of 45° and sloped to a maximum of 45°. Hangers 5 1/2" or less in width may be skewed to 67 1/2°. Hangers skewed 51°- 67 1/2° require a square cut.
- For all options, uplift loads are 0.75 of table loads.
- For skewed hangers 3 9/16" and less in width, the allowable download is 100% of the table load. For skewed hangers over 3 9/16" in width the allowable download is 80% of the table load. For slope only, the allowable download is 100% of the table load.
- For combined slopes and skewes, the maximum allowable download is 0.80 of the table load.
- For sloped and skewed hangers, the flange on the acute side flange can be concealed at 0.80 of the table load. Contact Simpson Strong-Tie for skew limitations.
- See Hanger Options on pages 233-243 for additional information.
- HU only—Rough beam sizes available by special order.
- See page 83 for stocked U hanger rough sizes tables.
- Also see LUS and HUS series.

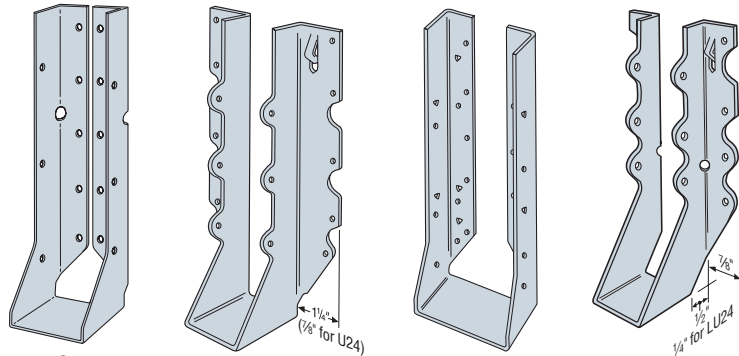

LUC210Z
(LUC26Z Similar) **U210**
HUC412
Concealed Flanges **LU28**
(except LU Roughs)

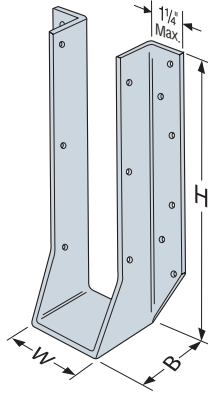

HU214
Projection seat on most models for maximum bearing and section economy.

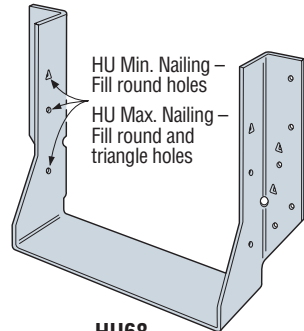

HU68

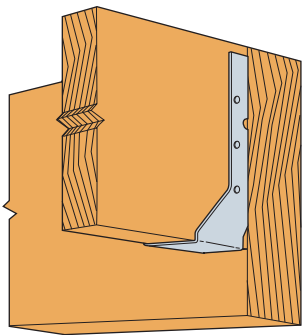

Typical LUCZ Installation

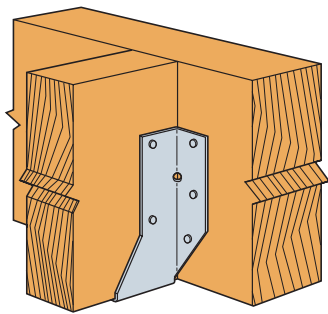

Typical HU Installation

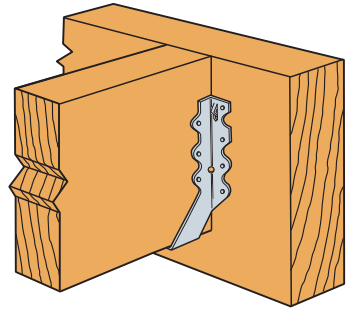

Typical LU28 Installation

Model configurations may differ from those shown. Some HU models do not have triangle holes. Contact Simpson Strong-Tie.

HUCQ Heavy-Duty Joist Hangers

The HUCQ series are heavy-duty joist hangers that incorporate Simpson Strong-Tie® Strong-Drive® SDS Heavy-Duty Connector screws. Designed and tested for installation at the end of a beam or on a post, they provide a strong connection with fewer fasteners than nailed hangers. See page 117 for structural composite lumber hangers.

MATERIAL: 14 gauge

FINISH: Galvanized. Most models available in stainless steel or ZMAX® coating.

INSTALLATION: • Use all specified fasteners. See General Notes.

- Install ¼"x2½" Strong-Drive SDS Heavy-Duty Connector screws, which are provided, in all round holes. (*Lag screws will not achieve the same load.*)
- For use on solid sawn wood members.

OPTIONS: These hangers cannot be modified.

CODES: See page 12 for Code Reference Key Chart.

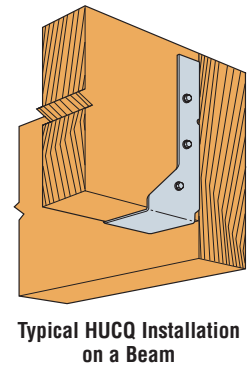
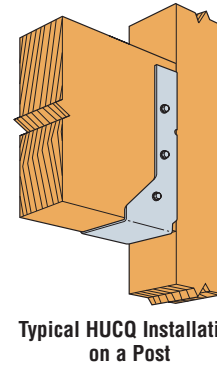
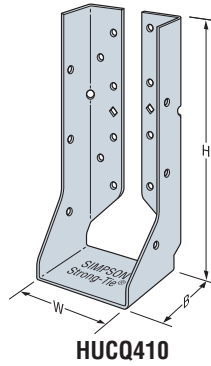

Typical HUCQ Installation on a Post

Typical HUCQ Installation on a Beam

Solid Sawn Joist Hangers

These products are available with additional corrosion protection. Additional products on this page may also be available with this option, check with Simpson Strong-Tie for details.

Model No.	Dimensions			Fasteners		Allowable Loads								Code Ref.
	W	H	B	Face	Joist	DF/SP				SPF/HF				
						Uplift (160)	Floor (100)	Snow (115)	Roof (125)	Uplift (160)	Floor (100)	Snow (115)	Roof (125)	
HUCQ310-SDS	2⅞	9	3	8-SDS ¼"x2½"	4-SDS ¼"x2½"	1370	3120	3590	3900	985	2245	2585	2810	F23
HUCQ210-2-SDS	3¼	9	3	12-SDS ¼"x2½"	6-SDS ¼"x2½"	2510	4680	4955	4955	1805	3370	3570	3570	
HUCQ410-SDS	3⅞	9	3	12-SDS ¼"x2½"	6-SDS ¼"x2½"	2510	4680	4955	4955	1805	3370	3570	3570	L12, F23, I9
HUCQ412-SDS	3⅞	11	3	14-SDS ¼"x2½"	6-SDS ¼"x2½"	2510	5460	5560	5560	1805	3930	4005	4005	F23
HUCQ210-3-SDS	4⅞	9	3	12-SDS ¼"x2½"	6-SDS ¼"x2½"	2510	4680	4955	4955	1805	3370	3570	3570	
HUCQ610-SDS	5½	9	3	12-SDS ¼"x2½"	6-SDS ¼"x2½"	2520	4680	5380	5715	1815	3370	3875	4115	I9, L12, F23
HUCQ612-SDS	5½	11	3	14-SDS ¼"x2½"	6-SDS ¼"x2½"	2520	5315	5315	5315	1815	3825	3825	3825	F23

1. Uplift loads have been increased for wind or earthquake loading. Reduce where other loads govern.
2. See page 101 for additional engineered wood product sizes.

3. Structural composite lumber columns have sides that show either the wide face or the edges of the lumber strands/veneers. Values in the tables reflect installation into the wide face. See technical bulletin T-SCLCOLUMN for values on the narrow face (edge).

LOAD TABLE EXPLANATION

This icon identifies products approved for installation with the Simpson Strong-Tie® Strong-Drive® SD Connector screw. See page 27 for more information.

Min/Max: Refers to min. or max. nailing for products with round and triangle holes. Min. nailing uses round holes, and max. nailing uses round and triangle holes to achieve maximum load.

Load Duration: Assumed duration factor used to determine the allowable load.

Allowable Design Loads: The maximum load that a connection is designed to provide. There may be multiple design loads acting in different directions (*up, down, lateral, perpendicular, etc.*) imposed on a connection.

Code Ref.: See page 12 for the Code Reference Key Chart, to determine which code reports include this product.

Joist Size: This shows the size of joist member.

Model No.: This is the Simpson Strong-Tie product name.

Gauge: Product material

Nails: This shows the fastener quantity and type required to achieve the table loads.

Uplift **Floor, Snow, Roof**

Installed Cost Index: This indicates the products relative installed cost (*combined cost and installation cost*).

Joist Size	Model No.	Ga	Dimensions (in.)				Min/Max	Fasteners		DF/SP Allowable Loads				Installed Cost Index (ICI)	Code Ref.
			W	H	B			Header	Joist	Uplift (160)	Floor (100)	Snow (115)	Roof (125)		
SAWN LUMBER SIZES															
DBL 2X6	LUS26-2	18	3⅞	4⅞	2	—	4-16d	4-16d	1165	1030	1180	1280	Lowest	I7, I27, F6, L5, L17	
	U26-2	16	3⅞	5	2	—	8-16d	4-10d	740	1150	1305	1410	+65%	I7, F6, L17	
	HUS26-2/HUSC26-2	14	3⅞	5⅞	2	—	4-16d	4-16d	1235	1065	1210	1305	+172%		
	HU26-2/HUC26-2	14	3⅞	5⅞	2½	Min	8-16d	4-10d	760	1190	1345	1445	+233%	I7, I27, F6, L5, L17	
		14	3⅞	5⅞	2½	Max	12-16d	6-10d	1135	1785	2015	2165	+254%	I7, F6, L17	

This icon identifies products that are available with additional corrosion protection. See pages 13-15 for additional information.

Dimensions W, H, B: This shows the product dimensions (*width, height and base in this case*) referenced in the product drawing.

NAILS: 16d = 0.162" dia. x 3½" long, 10d x 1½ = 0.148" dia. x 1½" long. See pages 22-23 for other nail sizes and information.

Throughout this catalog a footnote will typically be provided indicating the required nail diameter and length. All installations should be designed only in accordance with the allowable load values set forth in this catalog.

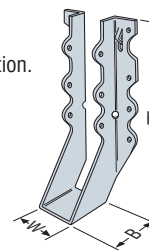

Product Drawing: Provides a graphic presentation of the product with dimensional information (*often cross referenced to the table*).

CATALOG DEFINITION:

Deflection: The distance a point moves when a load is applied.

LUS/HUS/HHUS/HGUS Double Shear Joist Hangers



This product is preferable to similar connectors because of
a) easier installation, b) higher loads, c) lower installed cost,
or a combination of these features.

See Hanger tables on pages 77-82. See Hanger Options on pages 233-243 for hanger modifications, which may result in reduced loads.

All hangers in this series have double shear nailing. This innovation distributes the load through two points on each joist nail for greater strength. It also allows the use of fewer nails, faster installation, and the use of standard nails for all connections. (Do not bend or remove tabs.)

MATERIAL: See tables, pages 77-82.

FINISH: Galvanized. Some products available in stainless steel or ZMAX® coating; see Corrosion Information, pages 13-15.

INSTALLATION • Use all specified fasteners. See General Notes.

- Nails must be driven at an angle through the joist or truss into the header to achieve the table loads.
- Not designed for welded or nailer applications.
- 16d sinkers (0.148" dia. x 3 3/4" long) may be used where 10d commons are specified with no reduction in load. Where 16d commons are specified, 10d commons or 16d sinkers (0.148" dia. x 3 3/4" long) may be used at 0.85 of the table load.
- With 3x carrying members, use 16dx2 1/2" nails into the header and 16d commons into the joist with no load reduction.
- With 2x carrying members, use 10dx1 1/2" nails into the header and 10d commons into the joist, reduce the load to 0.64 of the table value.
- Use stainless-steel (SS) nails with stainless-steel (SS) hangers.

OPTIONS: • LUS hangers cannot be modified.

- HUS hangers available with the header flanges turned in for 2-2x (3 1/8") and 4x only, with no load reduction. See the HUSC Concealed Flange illustration.

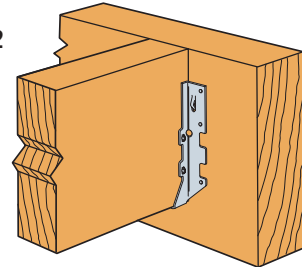
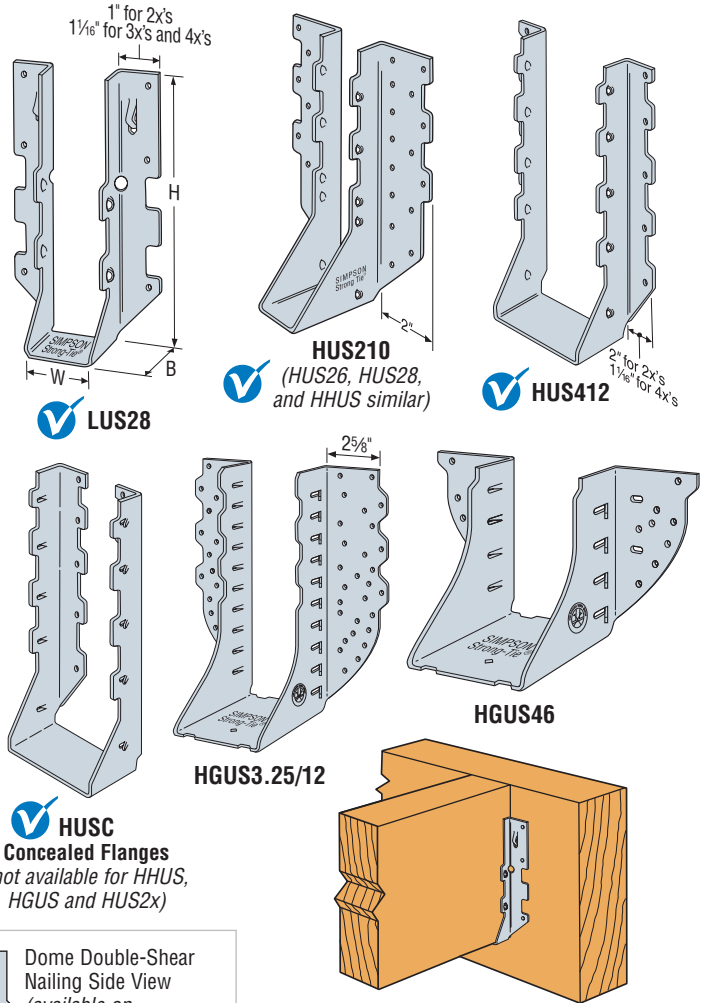

Typical LUS28 Installation
use 0.148x3" (10d common)
or 0.148x3 3/4" (16d sinker) nail



Double-Shear Nailing Top View

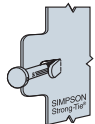

Double-Shear Nailing Side View
Do not bend tab

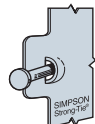

Dome Double-Shear Nailing Side View
(available on some models)
U.S. Patent 5,603,580

FACE MOUNT HANGERS – SOLID SAWN LUMBER (DF/SP)

These products are available with additional corrosion protection. Additional products on this page may also be available with this option, check with Simpson Strong-Tie for details.

These products are approved for installation with the Strong-Drive® SD Connector screw. See page 27 for more information.

Joist Size	Model No.	Ga	Dimensions (in.)			Min/Max	Fasteners		DF/SP Allowable Loads				Installed Cost Index (ICI)	Code Ref.
			W	H	B		Header	Joist	Uplift (160)	Floor (100)	Snow (115)	Roof (125)		
SAWN LUMBER SIZES														
2X4	LUS24	20	1 1/16	3 3/8	1 1/2	—	4-16d	2-10dx1 1/2	265	555	635	685	Lowest	17, I27, F6, L5, L17
	LUS24	18	1 1/16	3 3/8	1 3/4	—	4-10d	2-10d	490	670	765	825	+3%	
	U24	16	1 1/16	3 3/8	1 1/2	—	4-16d	2-10dx1 1/2	265	575	655	705	+67%	
	HU26	14	1 1/16	3 1/8	2 1/4	—	4-16d	2-10dx1 1/2	335	595	670	720	+295%	
DBL 2X4	LUS24-2	18	3 3/8	3 3/8	2	—	4-16d	2-16d	440	800	910	985	Lowest	17, I27, F6, L5, L17
	U24-2	16	3 1/8	3	2	—	4-16d	2-10d	370	575	655	705	+33%	
	HU24-2/HUC24-2	14	3 1/8	3 1/8	2 1/2	—	4-16d	2-10d	380	380	595	720	+240%	
2x6	LUS26	18	1 1/16	4 3/4	1 3/4	—	4-10d	4-10d	1165	865	990	1070	Lowest	17, I27, F6, L5, L17
	LU26	20	1 1/16	4 3/4	1 1/2	—	6-16d	4-10dx1 1/2	565	835	950	1030	+6%	
	U26	16	1 1/16	4 3/4	2	—	6-16d	4-10dx1 1/2	585	865	980	1055	+43%	
	LUC26Z	18	1 1/16	4 3/4	1 3/4	—	6-16d	4-10dx1 1/2	730	845	965	1040	+160%	
	HU26	14	1 1/16	3 1/8	2 1/4	—	4-16d	2-10dx1 1/2	335	335	595	720	+179%	
	HUS26	16	1 5/8	5 3/8	3	—	14-16d	6-16d	1550	2720	3095	3335	+276%	
DBL 2X6	LUS26-2	18	3 3/8	4 3/8	2	—	4-16d	4-16d	1165	1030	1180	1280	Lowest	17, I27, F6, L5, L17
	U26-2	16	3 3/8	5	2	—	8-16d	4-10d	740	1150	1305	1410	+65%	
	HUS26-2/HUSC26-2	14	3 1/8	5 3/8	2	—	4-16d	4-16d	1235	1065	1210	1305	+172%	
	HU26-2/HUC26-2	14	3 1/8	5 3/8	2 1/2	Min	8-16d	4-10d	760	1190	1345	1445	+233%	
		14	3 1/8	5 3/8	2 1/2	Max	12-16d	6-10d	1135	1785	2015	2165	+254%	17, F6, L17

See footnotes on page 79.

CODES: See page xx for Code Reference Key Chart.

FACE MOUNT HANGERS – SOLID SAW LUMBER (DF/SP)

These products are available with additional corrosion protection. Additional products on this page may also be available with this option, check with Simpson Strong-Tie for details.

These products are approved for installation with the Strong-Drive® SD Connector screw. See page 27 for more information.

Joist Size	Model No.	Ga	Dimensions (in.)			Min/Max	Fasteners		DF/SP Allowable Loads				Installed Cost Index (ICI)	Code Ref.	
			W	H	B		Header	Joist	Uplift (160)	Floor (100)	Snow (115)	Roof (125)			
SAWN LUMBER SIZES															
TPL 2x6	LUS26-3	18	4 ⁵ / ₁₆	4 ¹ / ₄	2		4-16d	4-16d	1165	1030	1180	1280	*	160	
	U26-3	16	4 ⁵ / ₁₆	4 ¹ / ₄	2		8-16d	4-10d	740	1150	1305	1410	*		
	HU26-3/HUC26-3	14	4 ¹¹ / ₁₆	5 ¹ / ₂	2 ¹ / ₂	Min	8-16d	4-10d	760	1190	1345	1445	*		
						Max	12-16d	6-10d	1135	1785	2015	2165	*		
2x8	LUS26	18	1 ¹ / ₁₆	4 ³ / ₄	1 ³ / ₄	—	4-10d	4-10d	1165	865	990	1070	Lowest	17, I27, F6, L5, L17	
	LU26	20	1 ¹ / ₁₆	4 ³ / ₄	1 ¹ / ₂	—	6-16d	4-10dx1 ¹ / ₂	565	835	950	1030	+6%		
	LUS28	18	1 ¹ / ₁₆	6 ⁵ / ₈	1 ³ / ₄	—	6-10d	4-10d	1165	1100	1255	1360	+23%		
	LU28	20	1 ¹ / ₁₆	6 ⁵ / ₈	1 ¹ / ₂	—	8-16d	6-10dx1 ¹ / ₂	850	1110	1270	1335	+39%		
	U26	16	1 ¹ / ₁₆	4 ³ / ₄	2	—	6-16d	4-10dx1 ¹ / ₂	585	865	980	1055	+43%		
	LUC26Z	18	1 ¹ / ₁₆	4 ³ / ₄	1 ³ / ₄	—	6-16d	4-10dx1 ¹ / ₂	730	845	965	1040	+160%		
	HU28	14	1 ¹ / ₁₆	5 ¹ / ₄	2 ¹ / ₄	—	6-16d	4-10dx1 ¹ / ₂	610	895	1005	1085	+251%		
	HUS26	16	1 ¹ / ₈	5 ³ / ₈	3	—	14-16d	6-16d	1550	2720	3095	3335	+276%		
HUS28	16	1 ¹ / ₈	7	3	—	22-16d	8-16d	2000	3965	4120	4220	+409%			
DBL 2x8	LUS26-2	18	3 ¹ / ₈	4 ⁷ / ₈	2	—	4-16d	4-16d	1165	1030	1180	1280	Lowest	17, I27, F6, L5, L17	
	LUS28-2	18	3 ¹ / ₈	7	2	—	6-16d	4-16d	1165	1315	1500	1625	+8%		
	U26-2	16	3 ¹ / ₈	5	2	—	8-16d	4-10d	740	1150	1305	1410	+65%		
	HUS28-2/HUSC28-2	14	3 ¹ / ₈	7 ³ / ₁₆	2	—	6-16d	6-16d	1550	1595	1815	1960	+188%		
	HU28-2/HUC28-2	14	3 ¹ / ₈	7	2 ¹ / ₂	Min	10-16d	4-10d	760	1490	1680	1805	+397%		
					Max	14-16d	6-10d	1135	2085	2350	2530	+418%			
TPL 2x8	LUS28-3	18	4 ⁵ / ₁₆	6 ¹ / ₄	2	—	6-16d	4-16d	1165	1315	1500	1625	*	160	
	U26-3	16	4 ⁵ / ₁₆	4 ¹ / ₄	2	—	8-16d	4-10d	740	1150	1305	1410	*		
	HU26-3/HUC26-3	14	4 ¹¹ / ₁₆	5 ¹ / ₂	2 ¹ / ₂	Min	8-16d	4-10d	760	1190	1345	1445	*		
					Max	12-16d	6-10d	1135	1785	2015	2165	*			
QUAD 2x8	HU28-4/HUC28-4	14	14	6 ¹ / ₈	6 ⁵ / ₈	Min	10-16d	4-16d	900	1490	1680	1805	*		
					Max	14-16d	6-16d	1345	2085	2350	2530	*			
2x10	LUS28	18	1 ¹ / ₁₆	6 ⁵ / ₈	1 ³ / ₄	—	6-10d	4-10d	1165	1100	1255	1360	Lowest	17, I27, F6, L5, L17	
	LU28	20	1 ¹ / ₁₆	6 ⁵ / ₈	1 ¹ / ₂	—	8-16d	6-10dx1 ¹ / ₂	850	1110	1270	1335	+13%		
	LUS210	18	1 ¹ / ₁₆	7 ¹³ / ₁₆	1 ³ / ₄	—	8-10d	4-10d	1165	1340	1525	1650	+15%		
	LU210	20	1 ¹ / ₁₆	7 ¹³ / ₁₆	1 ¹ / ₂	—	10-16d	6-10dx1 ¹ / ₂	850	1390	1585	1715	+28%		
	U210	16	1 ¹ / ₁₆	7 ¹³ / ₁₆	2	—	10-16d	6-10dx1 ¹ / ₂	1110	1440	1635	1685	+76%		
	LUC210Z	18	1 ¹ / ₁₆	7 ³ / ₄	1 ³ / ₄	—	10-16d	6-10dx1 ¹ / ₂	1100	1410	1605	1735	+180%		
	HU210	14	1 ¹ / ₁₆	7 ¹ / ₈	2 ¹ / ₄	—	8-16d	4-10dx1 ¹ / ₂	610	1190	1345	1445	+225%		
	HUS210	16	1 ¹ / ₈	9	3	—	30-16d	10-16d	3000	4255	4445	4575	+450%		
DBL 2x10	LUS28-2	18	3 ¹ / ₈	7	2	—	6-16d	4-16d	1165	1315	1500	1625	Lowest	17, I27, F6, L5, L17	
	LUS210-2	18	3 ¹ / ₈	9	2	—	8-16d	6-16d	1745	1830	2090	2265	+34%		
	U210-2	16	3 ¹ / ₈	8 ¹ / ₂	2	—	14-16d	6-10d	1110	2015	2285	2465	+88%		
	HUS210-2/HUSC210-2	14	3 ¹ / ₈	9 ³ / ₁₆	2	—	8-16d	8-16d	3295	2125	2420	2615	+217%		
	HU210-2/HUC210-2	14	3 ¹ / ₈	8 ¹³ / ₁₆	2 ¹ / ₂	Min	14-16d	6-10d	1135	2085	2350	2530	+441%		
						Max	18-16d	10-10d	1895	2680	3020	3250	+467%		
	HUCQ210-2-SDS	14	2 ⁹ / ₁₆	9	3	—	12-1/4"x2 1/2" SDS	6-1/4"x2 1/2" SDS	2510	4680	4955	4955	*		F23
HHUS210-2	14	3 ⁵ / ₁₆	9 ⁹ / ₃₂	3	—	30-16d	10-16d	4000	5635	6380	6880	*	F23		
TPL 2x10	LUS28-3	18	4 ⁵ / ₁₆	6 ¹ / ₄	2	—	6-16d	4-16d	1165	1315	1500	1625	*	160	
	LUS210-3	18	4 ⁵ / ₁₆	8 ³ / ₁₆	2	—	8-16d	6-16d	1745	1830	2090	2265	*		
	U210-3	16	4 ⁵ / ₁₆	7 ³ / ₄	2	—	14-16d	6-10d	1110	2015	2285	2465	*		
	HU210-3/HUC210-3	14	4 ¹¹ / ₁₆	8 ⁹ / ₁₆	2 ¹ / ₂	Min	14-16d	6-10d	1135	2085	2350	2530	*		
						Max	18-16d	10-10d	1895	2680	3020	3250	*		
	HHUS210-3	14	4 ¹¹ / ₁₆	8 ⁷ / ₈	3	—	30-16d	10-16d	4000	5635	6380	6880	*		
	HGUS210-3	12	4 ¹ / ₁₆	9 ¹ / ₈	4	—	46-16d	16-16d	4095	9100	9100	9100	*		
	HUCQ210-3-SDS	14	4 ⁵ / ₁₆	9	3	—	8-1/4"x2 1/2" SDS	4-1/4"x2 1/2" SDS	2510	4680	4955	4955	*		F23
	HU210-4/HUC210-4	14	6 ¹ / ₈	8 ⁵ / ₈	2 ¹ / ₂	Min	14-16d	6-16d	1345	2085	2350	2530	*		
					Max	18-16d	8-16d	1795	2680	3020	3250	*			
HHUS210-4	14	6 ¹ / ₈	8 ⁷ / ₈	3	—	30-16d	10-16d	4000	5635	6380	6880	*			
HGUS210-4	12	6 ¹ / ₁₆	9 ¹ / ₈	4	—	46-16d	16-16d	4095	9100	9100	9100	*			
2x12	LUS210	18	1 ¹ / ₁₆	7 ¹³ / ₁₆	1 ³ / ₄	—	8-10d	4-10d	1165	1340	1525	1650	Lowest	17, I27, F6, L5, L17	
	LU210	20	1 ¹ / ₁₆	7 ¹³ / ₁₆	1 ¹ / ₂	—	10-16d	6-10dx1 ¹ / ₂	850	1390	1585	1715	+11%		
	U210	16	1 ¹ / ₁₆	7 ¹³ / ₁₆	2	—	10-16d	6-10dx1 ¹ / ₂	1110	1440	1635	1685	+53%		
	LUC210Z	18	1 ¹ / ₁₆	7 ³ / ₄	1 ³ / ₄	—	10-16d	6-10dx1 ¹ / ₂	1100	1410	1605	1735	+180%		
	HU212	14	1 ¹ / ₁₆	9	2 ¹ / ₄	—	10-16d	6-10dx1 ¹ / ₂	1135	1490	1680	1805	+347%		
	HUS210	16	1 ¹ / ₈	9	3	—	30-16d	10-16d	3000	4255	4445	4575	+378%		
	LUS210-2	18	3 ¹ / ₈	9	2	—	8-16d	6-16d	1745	1830	2090	2265	Lowest		
	U210-2	16	3 ¹ / ₈	8 ¹ / ₂	2	—	14-16d	6-10d	1110	2015	2285	2465	+40%		
LUS214-2	18	3 ¹ / ₈	10 ¹ / ₁₆	2	—	10-16d	6-16d	1745	2110	2410	2610	+56%			
DBL 2x12	HUS210-2	14	3 ¹ / ₈	9 ¹ / ₁₆	2	—	8-16d	8-16d	3295	2125	2420	2615	*	17, F6, L17	
	HUS212-2/HUSC212-2	14	3 ¹ / ₈	10 ³ / ₄	2	—	10-16d	10-16d	3635	2660	3025	3265	*		
	HU212-2/HUC212-2	14	3 ¹ / ₈	10 ⁹ / ₁₆	2 ¹ / ₂	Min	16-16d	6-10d	1135	2380	2685	2890	*		
						Max	2 2-16d	10-10d	1895	3275	3695	3970	+411%		
	HUCQ210-2-SDS	14	2 ⁹ / ₁₆	9	3	—	12-1/4"x2 1/2" SDS	6-1/4"x2 1/2" SDS	2510	5460	5560	5560	*		F23

See footnotes on page 79.

CODES: See page 12 for Code Reference Key Chart.

FACE MOUNT HANGERS – SOLID SAWN LUMBER (DF/SP)

The new Joist Hanger Selector software enables you the most optimum product for your project. The software takes into consideration all the characteristics seen in this catalog. Visit www.strongtie.com/software.

Solid Sawn Joist Hangers

Joist Size	Model No.	Ga	Dimensions (in.)			Min/Max	Fasteners		DF/SP Allowable Loads				Installed Cost Index (ICI)	Code Ref.
			W	H	B		Header	Joist	Uplift (160)	Floor (100)	Snow (115)	Roof (125)		
SAWN LUMBER SIZES														
TPL 2x12	LUS210-3	18	4 ⁵ / ₁₆	8 ³ / ₁₆	2	—	8-16d	6-16d	1745	1830	2090	2265	*	160
	HUC212-3/HUC212-3	14	4 ¹¹ / ₁₆	10 ⁹ / ₁₆	2 ¹ / ₂	Min	16-16d	6-10d	1135	2380	2685	2890	*	17, F6, L17
		14	4 ¹¹ / ₁₆	10 ⁹ / ₁₆	2 ¹ / ₂	Max	2-2-16d	10-10d	1895	3275	3695	3970	*	
	U210-3	16	4 ⁵ / ₁₆	7 ³ / ₁₆	2	—	14-16d	6-10d	1110	2015	2285	2465	*	
	HUCQ210-3-SDS	14	4 ⁵ / ₁₆	9	3	—	12-1 ¹ / ₄ "x2 ¹ / ₂ " SDS	6-1 ¹ / ₄ "x2 ¹ / ₂ " SDS	2510	5460	5560	5560	*	F23
2x14	LUS210	18	1 ¹ / ₁₆	7 ¹³ / ₁₆	1 ³ / ₄	—	8-10d	4-10d	1165	1340	1525	1650	Lowest	
	LU210	20	1 ¹ / ₁₆	7 ¹³ / ₁₆	1 ³ / ₄	—	10-16d	6-10dx1 ¹ / ₂	850	1390	1585	1715	+11%	
	U210	16	1 ¹ / ₁₆	7 ¹³ / ₁₆	2	—	10-16d	6-10dx1 ¹ / ₂	1110	1440	1635	1685	+53%	
	HU214	14	1 ¹ / ₁₆	10 ¹ / ₁₆	2 ¹ / ₄	—	12-16d	6-10dx1 ¹ / ₂	1135	1785	2015	2165	+88%	
	U214	16	1 ¹ / ₁₆	10	2	—	12-16d	8-10dx1 ¹ / ₂	1115	1730	1960	2115	+147%	
DBL 2x14	U210-2	16	3 ¹ / ₈	8 ¹ / ₂	2	—	14-16d	6-10d	1110	2015	2285	2465	Lowest	
	LUS214-2	18	3 ¹ / ₈	10 ¹⁵ / ₁₆	2	—	10-16d	6-16d	1745	2110	2410	2610	+12%	17, F6, L17
	HUS212-2/HUC212-2	14	3 ¹ / ₈	10 ³ / ₁₆	2	—	10-16d	10-16d	3635	2660	3025	3265	+83%	F23
		14	3 ¹ / ₈	10 ⁹ / ₁₆	2 ¹ / ₂	Min	16-16d	6-10d	1135	2380	2685	2890	+248%	
		14	3 ¹ / ₈	10 ⁹ / ₁₆	2 ¹ / ₂	Max	2-2-16d	10-10d	1895	3275	3695	3970	+265%	
		14	3 ¹ / ₈	12 ¹ / ₁₆	2 ¹ / ₂	Min	18-16d	8-10d	1515	2680	3020	3250	+259%	
	14	3 ¹ / ₈	12 ¹ / ₁₆	2 ¹ / ₂	Max	24-16d	12-10d	2015	3570	4030	4335	+276%		
	HUCQ210-2-SDS	14	2 ⁵ / ₁₆	9	3	—	12-1 ¹ / ₄ "x2 ¹ / ₂ " SDS	6-1 ¹ / ₄ "x2 ¹ / ₂ " SDS	2510	4680	4955	4955	*	F23
TPL 2x14	U210-3	16	4 ⁵ / ₁₆	7 ³ / ₁₆	2	—	14-16d	6-10d	1110	2015	2285	2465	*	
	HU214-3/HUC214-3	14	4 ¹¹ / ₁₆	12 ¹ / ₁₆	2 ¹ / ₂	Min	18-16d	8-10d	1515	2680	3020	3250	*	17, F6, L17
		14	4 ¹¹ / ₁₆	12 ¹ / ₁₆	2 ¹ / ₂	Max	24-16d	12-10d	2015	3570	4030	4335	*	
	HUCQ210-3-SDS	14	4 ⁵ / ₁₆	9	3	—	12-1 ¹ / ₄ "x2 ¹ / ₂ " SDS	6-1 ¹ / ₄ "x2 ¹ / ₂ " SDS	2510	5460	5560	5560	*	F23
2x16	U214	16	1 ¹ / ₁₆	10	2	—	12-16d	8-10dx1 ¹ / ₂	1115	1730	1960	2115	Lowest	
	HU214	14	1 ¹ / ₁₆	10 ¹ / ₁₆	2 ¹ / ₄	—	12-16d	6-10dx1 ¹ / ₂	1135	1785	2015	2165	+130%	17, F6, L17
	HU216	14	1 ¹ / ₁₆	12 ¹⁵ / ₁₆	2 ¹ / ₄	—	18-16d	8-10dx1 ¹ / ₂	1515	2680	3020	3250	+130%	160
DBL 2x16	HUS212-2/HUC212-2	14	3 ¹ / ₈	10 ³ / ₁₆	2	—	10-16d	10-16d	3635	2660	3025	3265	Lowest	
		14	3 ¹ / ₈	13 ³ / ₁₆	2 ¹ / ₂	Min	20-16d	8-10d	1515	2975	3360	3610	+111%	17, F6, L17
	14	3 ¹ / ₈	13 ³ / ₁₆	2 ¹ / ₂	Max	26-16d	12-10d	2015	3870	4365	4695	+120%		
TPL 2x16	HU216-3/HUC216-3	14	4 ¹¹ / ₁₆	13 ³ / ₁₆	2 ¹ / ₂	Min	20-16d	8-10d	1515	2975	3360	3610	*	
		14	4 ¹¹ / ₁₆	13 ³ / ₁₆	2 ¹ / ₂	Max	26-16d	12-10d	2015	3870	4365	4695	*	
3x4	U34	16	2 ⁵ / ₁₆	3 ³ / ₈	2	—	4-16d	2-10dx1 ¹ / ₂	265	575	655	705	*	17, F8, L17
	HU34/HUC34	14	2 ⁵ / ₁₆	3 ³ / ₈	2 ¹ / ₂	—	4-16d	2-10dx1 ¹ / ₂	380	595	670	720	*	
3x6	U36	16	2 ⁵ / ₁₆	5 ³ / ₈	2	—	8-16d	4-10dx1 ¹ / ₂	585	1150	1305	1410	*	
	LUS36	18	2 ⁵ / ₁₆	5 ¹ / ₄	2	—	4-16d	4-16d	1165	1030	1180	1280	*	F23
	HU36/HUC36	14	2 ⁵ / ₁₆	5 ³ / ₈	2 ¹ / ₂	—	8-16d	4-10dx1 ¹ / ₂	610	1190	1345	1445	*	17, F6, L17
3x8	U36	16	2 ⁵ / ₁₆	5 ³ / ₈	2	—	8-16d	4-10dx1 ¹ / ₂	585	1150	1305	1410	*	
	LUS36	18	2 ⁵ / ₁₆	5 ¹ / ₄	2	—	4-16d	4-16d	1165	1030	1180	1280	*	F23
	HU38/HUC38	14	2 ⁵ / ₁₆	7 ³ / ₁₆	2 ¹ / ₂	—	10-16d	4-10dx1 ¹ / ₂	610	1490	1680	1805	*	17, F6, L17
3x10	U310	16	2 ⁵ / ₁₆	8 ³ / ₈	2	—	14-16d	6-10dx1 ¹ / ₂	1110	2015	2285	2465	*	
	LUS310	18	2 ⁵ / ₁₆	7 ¹ / ₄	2	—	6-16d	4-16d	1165	1315	1500	1625	*	F23
	HU310/HUC310	14	2 ⁵ / ₁₆	8 ³ / ₈	2 ¹ / ₂	—	14-16d	6-10dx1 ¹ / ₂	915	2085	2350	2530	*	17, F6, L17
	HUCQ310-SDS	14	2 ⁵ / ₁₆	9	3	—	8-1 ¹ / ₄ "x2 ¹ / ₂ " SDS	4-1 ¹ / ₄ "x2 ¹ / ₂ " SDS	1370	3120	3590	3900	*	F23
3x12	U310	16	2 ⁵ / ₁₆	8 ³ / ₈	2	—	14-16d	6-10dx1 ¹ / ₂	1110	2015	2285	2465	*	17, F6, L17
	LUS310	18	2 ⁵ / ₁₆	7 ³ / ₄	2	—	6-16d	4-16d	1165	1315	1500	1625	*	F23
	HU312/HUC312	14	2 ⁵ / ₁₆	10 ³ / ₁₆	2 ¹ / ₂	—	16-16d	6-10dx1 ¹ / ₂	915	2380	2685	2890	*	17, F6, L17
	HUCQ310-SDS	14	2 ⁵ / ₁₆	9	3	—	8-1 ¹ / ₄ "x2 ¹ / ₂ " SDS	4-1 ¹ / ₄ "x2 ¹ / ₂ " SDS	1370	3120	3590	3900	*	F23
3x14	U314	16	2 ⁵ / ₁₆	10 ¹ / ₂	2	—	16-16d	6-10dx1 ¹ / ₂	1110	2305	2615	2820	*	F8
	HU314/HUC314	14	2 ⁵ / ₁₆	12 ³ / ₁₆	2 ¹ / ₂	—	18-16d	8-10dx1 ¹ / ₂	1515	2680	3020	3250	*	17, F6, L17
	HUCQ310-SDS	14	2 ⁵ / ₁₆	9	3	—	8-1 ¹ / ₄ "x2 ¹ / ₂ " SDS	4-1 ¹ / ₄ "x2 ¹ / ₂ " SDS	1370	3120	3590	3900	*	F23
3x16	U314	16	2 ⁵ / ₁₆	10 ¹ / ₂	2	—	16-16d	6-10dx1 ¹ / ₂	1110	2305	2615	2820	*	
	HU316/HUC316	14	2 ⁵ / ₁₆	14 ¹ / ₁₆	2 ¹ / ₂	—	20-16d	8-10dx1 ¹ / ₂	1515	2975	3360	3610	*	
4x4	LUS44	18	3 ¹ / ₁₆	3	2	—	4-16d	2-16d	440	800	910	985	Lowest	17, F6, L17
	U44	16	3 ¹ / ₁₆	2 ⁷ / ₈	2	—	4-16d	2-10d	370	575	655	705	+20%	
	HU44/HUC44	14	3 ¹ / ₁₆	2 ⁷ / ₈	2 ¹ / ₂	—	4-16d	2-10d	380	595	670	720	+161%	
4x6	LUS46	18	3 ¹ / ₁₆	4 ³ / ₄	2	—	4-16d	4-16d	1165	1030	1180	1280	Lowest	
	U46	16	3 ¹ / ₁₆	4 ⁷ / ₈	2	—	8-16d	4-10d	740	1150	1305	1410	+37%	
	HUS46/HUC46	14	3 ¹ / ₁₆	5	2	—	4-16d	4-16d	1235	1065	1210	1305	+152%	17, F6, L17
		14	3 ¹ / ₁₆	5 ³ / ₁₆	2 ¹ / ₂	Min	8-16d	4-10d	760	1190	1345	1445	+163%	
	14	3 ¹ / ₁₆	5 ³ / ₁₆	2 ¹ / ₂	Max	12-16d	6-10d	1135	1785	2015	2165	+185%		
4x8	LUS46	18	3 ¹ / ₁₆	4 ³ / ₄	2	—	4-16d	4-16d	1165	1030	1180	1280	Lowest	
	U46	16	3 ¹ / ₁₆	4 ⁷ / ₈	2	—	8-16d	4-10d	740	1150	1305	1410	+37%	
	LUS48	18	3 ¹ / ₁₆	6 ³ / ₈	2	—	6-16d	4-16d	1165	1315	1500	1625	+40%	
	HUS48/HUC48	14	3 ¹ / ₁₆	6 ¹⁵ / ₁₆	2	—	6-16d	6-16d	1550	1595	1815	1960	+203%	17, F6, L17
		14	3 ¹ / ₁₆	6 ¹³ / ₁₆	2 ¹ / ₂	Min	10-16d	4-10d	760	1490	1680	1805	+213%	
	14	3 ¹ / ₁₆	6 ¹³ / ₁₆	2 ¹ / ₂	Max	14-16d	6-10d	1135	2085	2350	2530	+235%		

C-C-2015 © 2015 SIMPSON STRONG-TIE COMPANY INC. PRINTED 12/14 (This page has been updated since printing)

FACE MOUNT HANGERS – SOLID SAWN LUMBER (DF/SP)

These products are available with additional corrosion protection. Additional products on this page may also be available with this option, check with Simpson Strong-Tie for details.

CODES: See page 12 for Code Reference Key Chart.

Joist Size	Model No.	Ga	Dimensions (in.)				Min/Max	Fasteners		DF/SP Allowable Loads				Installed Cost Index (ICI)	Code Ref.
			W	H	B			Header	Joist	Uplift (160)	Floor (100)	Snow (115)	Roof (125)		
SAWN LUMBER SIZES															
4x10	LUS48	18	3 ¹ / ₁₆	6 ³ / ₄	2	—	6-16d	4-16d	1165	1315	1500	1625	Lowest	17, F6, L17	
	LUS410	18	3 ¹ / ₁₆	8 ³ / ₄	2	—	8-16d	6-16d	1745	1830	2090	2265	+19%		
	U410	16	3 ³ / ₁₆	8 ³ / ₈	2	—	14-16d	6-10d	1110	2015	2285	2465	+74%		
	HUS410/HUSC410	14	3 ³ / ₁₆	8 ¹ / ₁₆	2	—	8-16d	8-16d	3295	2125	2420	2615	+154%		
	HU410/HUC410	14	3 ³ / ₁₆	8 ⁵ / ₈	2 ¹ / ₂	Min	14-16d	6-10d	1135	2085	2350	2530	+232%		
			14	3 ³ / ₁₆	8 ⁵ / ₈	2 ¹ / ₂	Max	18-16d	10-10d	1895	2680	3020	3250		+253%
	HUCQ410-SDS	14	3 ³ / ₁₆	9	3	—	12-1/4"x2 1/2" SDS	6-1/4"x2 1/2" SDS	2510	4680	4955	4955	*	19, L12, F23	
4x12	LUS410	18	3 ³ / ₁₆	8 ³ / ₄	2	—	8-16d	6-16d	1745	1830	2090	2265	Lowest	17, F6, L17	
	LUS414	18	3 ³ / ₁₆	10 ³ / ₄	2	—	10-16d	6-16d	1745	2110	2410	2610	+33%		
	U410	16	3 ³ / ₁₆	8 ³ / ₈	2	—	14-16d	6-10d	1110	2015	2285	2465	+46%		
	HUS410/HUSC410	14	3 ³ / ₁₆	8 ⁵ / ₈	2	—	8-16d	8-16d	3295	2125	2420	2615	+114%		
	HUS412	14	3 ³ / ₁₆	10 ¹ / ₂	2	—	10-16d	10-16d	3635	2660	3025	3265	+129%		
	HU412/HUC412	14	3 ³ / ₁₆	10 ⁵ / ₁₆	2 ¹ / ₂	Min	16-16d	6-10d	1135	2380	2685	2890	+268%		
		14	3 ³ / ₁₆	10 ⁵ / ₁₆	2 ¹ / ₂	Max	22-16d	10-10d	1895	3275	3695	3970	+290%		
	HUCQ410-SDS	14	3 ³ / ₁₆	9	3	—	12-1/4"x2 1/2" SDS	6-1/4"x2 1/2" SDS	2510	4680	4955	4955	*	19, L12, F23	
	HUCQ412-SDS	14	3 ³ / ₁₆	11	3	—	14-1/4"x2 1/2" SDS	6-1/4"x2 1/2" SDS	2510	5460	5560	5560	*	F23	
4x14	LUS410	18	3 ³ / ₁₆	8 ³ / ₄	2	—	8-16d	6-16d	1745	1830	2090	2265	Lowest	17, F6, L17	
	LUS414	18	3 ³ / ₁₆	10 ³ / ₄	2	—	10-16d	6-16d	1745	2110	2410	2610	+33%		
	U414	16	3 ³ / ₁₆	10	2	—	16-16d	6-10d	1110	2305	2615	2820	+93%		
	HUS412/HUSC412	14	3 ³ / ₁₆	10 ¹ / ₂	2	—	10-16d	10-16d	3635	2660	3025	3265	+129%		
	HU414/HUC414	14	3 ³ / ₁₆	12 ⁵ / ₈	2 ¹ / ₂	Min	18-16d	8-10d	1515	2680	3020	3250	+333%		
			14	3 ³ / ₁₆	12 ⁵ / ₈	2 ¹ / ₂	Max	24-16d	12-10d	2015	3570	4030	4335		+355%
	HUCQ412-SDS	14	3 ³ / ₁₆	11	3	—	14-1/4"x2 1/2" SDS	6-1/4"x2 1/2" SDS	2510	5460	5560	5560	*	19, L12, F23	
4x16	U414	16	3 ³ / ₁₆	10	2	—	16-16d	6-10d	1110	2305	2615	2820	Lowest	17, F6, L17	
	HUS412/HUSC412	14	3 ³ / ₁₆	10 ¹ / ₂	2	—	10-16d	10-16d	3635	2660	3025	3265	+19%		
	HU416/HUC416	14	3 ³ / ₁₆	13 ⁵ / ₈	2 ¹ / ₂	Min	20-16d	8-10d	1515	2975	3360	3610	+167%		
		14	3 ³ / ₁₆	13 ⁵ / ₈	2 ¹ / ₂	Max	26-16d	12-10d	2015	3870	4365	4695	+178%		
6x6	U66	16	5 ¹ / ₂	5	2	—	8-16d	4-10d	740	1150	1305	1410	*	17, F6, L17	
	HU66/HUC66	14	5 ¹ / ₂	4 ³ / ₁₆	2 ¹ / ₂	Min	8-16d	4-16d	900	1190	1345	1445	*		
		14	5 ¹ / ₂	4 ³ / ₁₆	2 ¹ / ₂	Max	12-16d	6-16d	1345	1785	2015	2165	*		
6x8	U66	16	5 ¹ / ₂	5	2	—	8-16d	4-10d	740	1150	1305	1410	*	17, F6, L17	
	HU68/HUC68	14	5 ¹ / ₂	5 ¹ / ₁₆	2 ¹ / ₂	Min	10-16d	4-16d	900	1490	1680	1805	*		
		14	5 ¹ / ₂	5 ¹ / ₁₆	2 ¹ / ₂	Max	14-16d	6-16d	1345	2085	2350	2530	*		
6x10	U610	16	5 ¹ / ₂	8.5	2	—	14-16d	6-10d	1110	2015	2285	2465	*	17, F6, L17	
	HU610/HUC610	14	5 ¹ / ₂	7 ⁵ / ₈	2 ¹ / ₂	Min	14-16d	6-16d	1345	2085	2350	2530	*		
		14	5 ¹ / ₂	7 ⁵ / ₈	2 ¹ / ₂	Max	18-16d	8-16d	1795	2680	3020	3250	*		
	HUCQ610-SDS	14	5 ¹ / ₂	9	3	—	12-1/4"x2 1/2" SDS	6-1/4"x2 1/2" SDS	2520	4680	5380	5715	*	19, L12, F23	
6x12	HU612/HUC612	14	5 ¹ / ₂	9 ⁵ / ₈	2 ¹ / ₂	Min	16-16d	6-16d	1345	2380	2685	2890	*	17, F6, L17	
		14	5 ¹ / ₂	9 ⁵ / ₈	2 ¹ / ₂	Max	22-16d	8-16d	1795	3275	3695	3970	*		
	HUCQ610-SDS	14	5 ¹ / ₂	9	3	—	12-1/4"x2 1/2" SDS	6-1/4"x2 1/2" SDS	2520	4680	5380	5715	*		19, L12, F23
	HUCQ612-SDS	14	5 ¹ / ₂	11	3	—	14-1/4"x2 1/2" SDS	6-1/4"x2 1/2" SDS	2520	5315	5315	5315	*	19, L12, F23	
6x14	HU614/HUC614	14	5 ¹ / ₂	11 ⁵ / ₈	2 ¹ / ₂	Min	18-16d	8-16d	1795	2680	3020	3250	*	17, F6, L17	
		14	5 ¹ / ₂	11 ⁵ / ₈	2 ¹ / ₂	Max	24-16d	12-16d	2695	3570	4030	4335	*		
	HUCQ610-SDS	14	5 ¹ / ₂	9	3	—	12-1/4"x2 1/2" SDS	6-1/4"x2 1/2" SDS	2520	4680	5380	5715	*		19, L12, F23
	HUCQ612-SDS	14	5 ¹ / ₂	11	3	—	14-1/4"x2 1/2" SDS	6-1/4"x2 1/2" SDS	2520	5315	5315	5315	*	19, L12, F23	
6x16	HU616/HUC616	14	5 ¹ / ₂	12 ¹ / ₁₆	2 ¹ / ₂	Min	20-16d	8-16d	1795	2975	3360	3610	*	17, F6, L17	
		14	5 ¹ / ₂	12 ¹ / ₁₆	2 ¹ / ₂	Max	26-16d	12-16d	2695	3870	4365	4695	*		
	HUCQ612-SDS	14	5 ¹ / ₂	11	3	—	14-1/4"x2 1/2" SDS	6-1/4"x2 1/2" SDS	2520	5315	5315	5315	*		19, L12, F23
8x8	HU88/HUC88	14	7 ¹ / ₂	6 ⁵ / ₈	2 ¹ / ₂	Min	10-16d	4-16d	900	1490	1680	1805	*	17, F6, L17	
		14	7 ¹ / ₂	6 ⁵ / ₈	2 ¹ / ₂	Max	14-16d	6-16d	1345	2085	2350	2530	*		
8x10	HU810/HUC810	14	7 ¹ / ₂	8 ⁵ / ₈	2 ¹ / ₂	Min	14-16d	6-16d	1345	2085	2350	2530	*	17, F6, L17	
		14	7 ¹ / ₂	8 ⁵ / ₈	2 ¹ / ₂	Max	18-16d	8-16d	1795	2680	3020	3250	*		
8x12	HU812/HUC812	14	7 ¹ / ₂	10 ¹ / ₈	2 ¹ / ₂	Min	16-16d	6-16d	1345	2380	2685	2890	*	160	
		14	7 ¹ / ₂	10 ¹ / ₈	2 ¹ / ₂	Max	22-16d	8-16d	1795	3275	3695	3970	*		
8x14	HU814/HUC814	14	7 ¹ / ₂	11 ⁵ / ₈	2 ¹ / ₂	Min	18-16d	8-16d	1795	2680	3020	3250	*	17, F6, L17	
		14	7 ¹ / ₂	11 ⁵ / ₈	2 ¹ / ₂	Max	24-16d	12-16d	2695	3570	4030	4335	*		
8x16	HU816/HUC816	14	7 ¹ / ₂	13 ⁵ / ₈	2 ¹ / ₂	Min	20-16d	8-16d	1795	2975	3360	3610	*	17, F6, L17	
		14	7 ¹ / ₂	13 ⁵ / ₈	2 ¹ / ₂	Max	26-16d	12-16d	2695	3870	4365	4695	*		

- Uplift loads apply to 10d and 16d header fasteners. Uplift loads have been increased for wind or earthquake loading with no further increase allowed. Reduce where other loads govern.
- 10d commons or 16d sinkers may be used instead of the specified 16d at 0.84 of the table load value.
- 16d sinkers may be used instead of the specified 10d commons with no load reduction. (16d sinkers are not acceptable for HDG applications.)
- MIN nailing quantity and load values—fill all round holes; MAX nailing quantity and load values—fill all round and triangle holes.

- DF/SP loads can be used for SCL that has fastener holding capacity of Doug Fir.
- Truss chord cross-grain tension may limit allowable loads in accordance with ANSI/TPI 1-2007. Simpson Strong-Tie® Connector Selector™ Software includes the evaluation of cross-grain tension in its hanger allowable loads. For additional information, contact Simpson Strong-Tie.
- NAILS:** 16d = 0.162" dia. x 3 1/2" long, 10d = 0.148" dia. x 3" long, 10dx1 1/2 = 0.148" dia. x 1 1/2" long. See pages 22-23 for other nail sizes and information.

*Hangers do not have an Installed Cost Index.

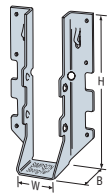

FACE MOUNT HANGERS – SOLID SAWN LUMBER (SPF/HF)

These products are available with additional corrosion protection. Additional products on this page may also be available with this option, check with Simpson Strong-Tie for details.

These products are approved for installation with the Strong-Drive® SD Connector screw. See page 27 for more information.

Solid Sawn Joist Hangers

Joist Size	Model No.	Ga	Dimensions (in.)			Min/Max	Fasteners		SPF/HF Allowable Loads			
			W	H	B		Header	Joist	Uplift (160)	Floor (100)	Snow (115)	Roof (125)
SAWN LUMBER SIZES												
2x4	LU24	20	1 ¹ / ₁₆	3 ¹ / ₈	1 ¹ / ₂	—	4-16d	2-10dx1 ¹ / ₂	230	475	545	590
	LUS24	18	1 ¹ / ₁₆	3 ¹ / ₈	1 ³ / ₄	—	4-10d	2-10d	420	575	655	705
	U24	16	1 ¹ / ₁₆	3 ¹ / ₈	1 ¹ / ₂	—	4-16d	2-10dx1 ¹ / ₂	230	495	560	605
DBL 2x4	HU26	14	1 ¹ / ₁₆	3 ¹ / ₁₆	2 ¹ / ₄	—	4-16d	2-10dx1 ¹ / ₂	290	515	580	620
	LUS24-2	18	3 ¹ / ₈	3 ¹ / ₈	2	—	4-16d	2-16d	380	680	780	845
	U24-2	16	3 ¹ / ₈	3	2	—	4-16d	2-10d	320	495	560	605
2x6	HU24-2	14	3 ¹ / ₈	3 ¹ / ₁₆	2 ¹ / ₂	—	4-16d	2-10d	325	515	580	620
	LUS26	18	1 ¹ / ₁₆	4 ³ / ₄	1 ³ / ₄	—	4-10d	4-10d	1005	740	845	915
	LU26	20	1 ¹ / ₁₆	4 ³ / ₄	1 ¹ / ₂	—	6-16d	4-10dx1 ¹ / ₂	490	715	815	885
DBL 2x6	U26	16	1 ¹ / ₁₆	4 ³ / ₄	2	—	6-16d	4-10dx1 ¹ / ₂	500	745	845	910
	LUC26Z	18	1 ¹ / ₁₆	4 ³ / ₄	1 ³ / ₄	—	6-16d	4-10dx1 ¹ / ₂	630	725	825	895
	HU26	14	1 ¹ / ₁₆	3 ¹ / ₁₆	2 ¹ / ₄	—	4-16d	2-10dx1 ¹ / ₂	290	515	580	620
DBL 2x6	HUS26	16	1 ¹ / ₈	5 ¹ / ₈	3	—	14-16d	6-16d	1335	2330	2650	2820
	LUS26-2	18	3 ¹ / ₈	4 ⁷ / ₈	2	—	4-16d	4-16d	1000	880	1010	1090
	U26-2	16	3 ¹ / ₈	5	2	—	8-16d	4-10d	640	990	1125	1210
TPL 2x6	HUS26-2/HUSC26-2	14	3 ¹ / ₈	5 ³ / ₁₆	2	—	4-16d	4-16d	1060	910	1035	1120
	HU26-2/HUC26-2	14	3 ¹ / ₈	5 ³ / ₈	2 ¹ / ₂	Min	8-16d	4-10d	655	1025	1155	1245
	HU26-2/HUC26-2	14	3 ¹ / ₈	5 ³ / ₈	2 ¹ / ₂	Max	12-16d	6-10d	980	1540	1735	1865
TPL 2x6	LUS26-3	18	4 ⁷ / ₈	4 ¹ / ₈	2	—	4-16d	4-16d	1000	880	1010	1090
	U26-3	16	4 ⁷ / ₈	4 ¹ / ₄	2	—	8-16d	4-10d	640	990	1125	1210
	HU26-3/HUC26-3	14	4 ¹ / ₁₆	5 ¹ / ₂	2 ¹ / ₂	Min	8-16d	4-10d	655	1025	1155	1245
2x8	HU26-3/HUC26-3	14	4 ¹ / ₁₆	5 ¹ / ₂	2 ¹ / ₂	Max	12-16d	6-10d	980	1540	1735	1865
	LUS26	18	1 ¹ / ₁₆	4 ³ / ₄	1 ³ / ₄	—	4-10d	4-10d	1005	740	845	915
	LU26	20	1 ¹ / ₁₆	4 ³ / ₄	1 ¹ / ₂	—	6-16d	4-10dx1 ¹ / ₂	490	715	815	885
DBL 2x8	LUS28	18	1 ¹ / ₁₆	6 ³ / ₈	1 ³ / ₄	—	6-10d	4-10d	1005	940	1075	1165
	LU28	20	1 ¹ / ₁₆	6 ³ / ₈	1 ¹ / ₂	—	8-16d	6-10dx1 ¹ / ₂	730	950	1085	1145
	U26	16	1 ¹ / ₁₆	4 ³ / ₄	2	—	6-16d	4-10dx1 ¹ / ₂	500	745	845	910
DBL 2x8	LUC26Z	18	1 ¹ / ₁₆	4 ³ / ₄	1 ³ / ₄	—	6-16d	4-10dx1 ¹ / ₂	630	725	825	895
	HU28	14	1 ¹ / ₁₆	5 ¹ / ₄	2 ¹ / ₄	—	6-16d	4-10dx1 ¹ / ₂	525	770	870	935
	HUS26	16	1 ¹ / ₈	5 ¹ / ₈	3	—	14-16d	6-16d	1335	2330	2650	2820
DBL 2x8	HUS28	16	1 ¹ / ₈	7	3	—	22-16d	8-16d	1720	2905	3035	3125
	LUS26-2	18	3 ¹ / ₈	4 ⁷ / ₈	2	—	4-16d	4-16d	1000	880	1010	1090
	LUS28-2	18	3 ¹ / ₈	7	2	—	6-16d	4-16d	1000	1125	1285	1390
TPL 2x8	U26-2	16	3 ¹ / ₈	5	2	—	8-16d	4-10d	640	990	1125	1210
	HUS28-2/HUSC28-2	14	3 ¹ / ₈	7 ³ / ₁₆	2	—	6-16d	6-16d	1335	1365	1555	1680
	HU28-2/HUC28-2	14	3 ¹ / ₈	7	2 ¹ / ₂	Min	10-16d	4-10d	655	1280	1445	1555
QUAD 2x8	HU28-2/HUC28-2	14	3 ¹ / ₈	7	2 ¹ / ₂	Max	14-16d	6-10d	980	1795	2025	2180
	LUS28-3	18	4 ⁷ / ₈	6 ¹ / ₄	2	—	6-16d	4-16d	1000	1125	1285	1390
	U26-3	16	4 ⁷ / ₈	4 ¹ / ₄	2	—	8-16d	4-10d	640	990	1125	1210
2x10	HU26-3/HUC26-3	14	4 ¹ / ₁₆	5 ¹ / ₄	2 ¹ / ₂	Min	8-16d	4-10d	655	1025	1155	1245
	HU26-3/HUC26-3	14	4 ¹ / ₁₆	5 ¹ / ₄	2 ¹ / ₂	Max	12-16d	6-10d	980	1540	1735	1865
	HU28-4/HUC28-4	14	6 ¹ / ₈	6 ³ / ₈	2 ¹ / ₂	Min	10-16d	4-16d	775	1280	1445	1555
DBL 2x10	HU28-4/HUC28-4	14	6 ¹ / ₈	6 ³ / ₈	2 ¹ / ₂	Max	14-16d	6-16d	1160	1795	2025	2180
	LUS28	18	1 ¹ / ₁₆	6 ³ / ₈	1 ³ / ₄	—	6-10d	4-10d	1005	940	1075	1165
	LU28	20	1 ¹ / ₁₆	6 ³ / ₈	1 ¹ / ₂	—	8-16d	6-10dx1 ¹ / ₂	730	950	1085	1145
DBL 2x10	LUS210	18	1 ¹ / ₁₆	7 ¹³ / ₁₆	1 ³ / ₄	—	8-10d	4-10d	1005	1145	1305	1415
	LU210	20	1 ¹ / ₁₆	7 ¹³ / ₁₆	1 ¹ / ₂	—	10-16d	6-10dx1 ¹ / ₂	730	1190	1360	1470
	U210	16	1 ¹ / ₁₆	7 ¹³ / ₁₆	2	—	10-16d	6-10dx1 ¹ / ₂	960	1240	1405	1445
DBL 2x10	LUC210Z	18	1 ¹ / ₁₆	7 ³ / ₄	1 ³ / ₄	—	10-16d	6-10dx1 ¹ / ₂	945	1210	1380	1490
	HU210	14	1 ¹ / ₁₆	7 ¹ / ₈	2 ¹ / ₄	—	8-16d	4-10dx1 ¹ / ₂	525	1025	1155	1245
	HUS210	16	1 ¹ / ₈	9	3	—	30-16d	10-16d	2580	3150	3315	3425
TPL 2x10	LUS28-2	18	3 ¹ / ₈	7	2	—	6-16d	4-16d	1000	1125	1285	1390
	LUS210-2	18	3 ¹ / ₈	9	2	—	6-16d	6-16d	1500	1565	1785	1935
	U210-2	16	3 ¹ / ₈	8 ¹ / ₂	2	—	14-16d	6-10d	960	1735	1965	2120
QUAD 2x10	HUS210-2	14	3 ¹ / ₈	9 ³ / ₁₆	2	—	8-16d	8-16d	2820	1820	2070	2240
	HU210-2/HUC210-2	14	3 ¹ / ₈	8 ¹³ / ₁₆	2 ¹ / ₂	Min	14-16d	6-10d	980	1795	2025	2180
	HU210-2/HUC210-2	14	3 ¹ / ₈	8 ¹³ / ₁₆	2 ¹ / ₂	Max	18-16d	10-10d	1635	2305	2605	2800
DBL 2x10	HHUS210-2/HUSC210-2	14	3 ³ / ₁₆	8 ⁷ / ₈	3	—	30-16d	10-16d	3525	4835	5270	5380
	HUCQ310-SDS	14	2 ⁹ / ₁₆	9	3	—	8- ¹ / ₄ "x2 ¹ / ₂ " SDS	4- ¹ / ₄ "x2 ¹ / ₂ " SDS	985	2245	2585	2810
	LUS28-3	18	4 ⁷ / ₈	6 ¹ / ₄	2	—	6-16d	4-16d	1000	1125	1285	1390
TPL 2x10	LUS210-3	18	4 ⁷ / ₈	8 ³ / ₁₆	2	—	8-16d	6-16d	1500	1565	1785	1935
	U210-3	16	4 ⁷ / ₈	7 ³ / ₄	2	—	14-16d	6-10d	960	1735	1965	2120
	HU210-3/HUC210-3	14	4 ¹ / ₁₆	8 ³ / ₁₆	2 ¹ / ₂	Min	14-16d	6-10d	980	1795	2025	2180
DBL 2x10	HU210-3/HUC210-3	14	4 ¹ / ₁₆	8 ³ / ₁₆	2 ¹ / ₂	Max	18-16d	10-10d	1635	2305	2605	2800
	HHUS210-3	14	4 ¹ / ₁₆	8 ⁷ / ₈	3	—	30-16d	10-16d	3525	4835	5480	5910
	HUCQ210-3-SDS	14	4 ⁹ / ₁₆	9	3	—	12- ¹ / ₄ "x2 ¹ / ₂ " SDS	6- ¹ / ₄ "x2 ¹ / ₂ " SDS	1805	3370	3570	3570
QUAD 2x10	HU210-4/HUC210-4	14	6 ¹ / ₈	8 ³ / ₈	2 ¹ / ₂	Min	14-16d	6-16d	1160	1795	2025	2180
	HU210-4/HUC210-4	14	6 ¹ / ₈	8 ³ / ₈	2 ¹ / ₂	Max	18-16d	8-16d	1550	2305	2605	2800
	HHUS210-4	14	6 ¹ / ₈	8 ⁷ / ₈	3	—	30-16d	10-16d	3525	4835	5480	5910

C-C-2015 © 2015 SIMPSON STRONG-TIE COMPANY INC. PRINTED 12/14

FACE MOUNT HANGERS – SOLID SAWN LUMBER (SPF/HF)

These products are available with additional corrosion protection. Additional products on this page may also be available with this option, check with Simpson Strong-Tie for details.

These products are approved for installation with the Strong-Drive® SD Connector screw. See page 27 for more information.

Joist Size	Model No.	Ga	Dimensions (in.)			Min/Max	Fasteners		SPF/HF Allowable Loads				
			W	H	B		Header	Joist	Uplift (160)	Floor (100)	Snow (115)	Roof (125)	
SAWN LUMBER SIZES													
2x12	LUS210	18	1 ¹ / ₁₆	7 ¹³ / ₁₆	1 ³ / ₄	—	8-10d	4-10d	1005	1145	1305	1415	
	LU210	20	1 ¹ / ₁₆	7 ¹³ / ₁₆	1 ¹ / ₂	—	10-16d	6-10dx1 ¹ / ₂	730	1190	1360	1470	
	U210	16	1 ¹ / ₁₆	7 ¹³ / ₁₆	2	—	10-16d	6-10dx1 ¹ / ₂	960	1240	1405	1445	
	LUC210Z	18	1 ¹ / ₁₆	7 ³ / ₄	1 ³ / ₄	—	10-16d	6-10dx1 ¹ / ₂	945	1210	1380	1490	
	HU212	14	1 ¹ / ₁₆	9	—	—	10-16d	6-10dx1 ¹ / ₂	980	1280	1445	1555	
DBL 2x12	HUS210	16	1 ⁵ / ₈	9	3	—	30-16d	10-16d	2580	3150	3315	3425	
	LUS210-2	18	3 ¹ / ₈	9	2	—	8-16d	6-16d	1500	1565	1785	1935	
	U210-2	16	3 ¹ / ₈	8 ¹ / ₂	2	—	14-16d	6-10d	960	1735	1965	2120	
	LUS214-2	18	3 ¹ / ₈	10 ¹⁵ / ₁₆	2	—	10-16d	6-16d	1500	1805	2065	2235	
	HUS210-2/HUSC210-2	14	3 ¹ / ₈	9 ³ / ₁₆	2	—	8-16d	8-16d	2820	1820	2070	2240	
	HUS212-2/HUSC212-2	14	3 ¹ / ₈	10 ³ / ₄	2	—	10-16d	10-16d	3125	2275	2590	2795	
	HU212-2/HUC212-2	14	3 ¹ / ₈	10 ⁹ / ₁₆	2 ¹ / ₂	Min	16-16d	6-10d	980	2050	2315	2490	
		14	3 ¹ / ₈	10 ⁹ / ₁₆	2 ¹ / ₂	Max	22-16d	10-10d	1635	2820	3180	3425	
	HUCQ210-2-SDS	14	2 ⁵ / ₁₆	9	3	—	12- ¹ / ₄ "x2 ¹ / ₂ " SDS	6- ¹ / ₄ "x2 ¹ / ₂ " SDS	1805	3370	3570	3570	
TPL 2x12	LUS210-3	18	4 ⁵ / ₈	8 ³ / ₁₆	2	—	8-16d	6-16d	1500	1565	1785	1935	
	HU212-3/HUC212-3	14	4 ¹ / ₁₆	10 ⁹ / ₁₆	2 ¹ / ₂	Min	16-16d	6-10d	980	2050	2315	2490	
			14	4 ¹ / ₁₆	10 ⁹ / ₁₆	2 ¹ / ₂	Max	22-16d	10-10d	1635	2820	3180	3425
	U210-3	16	4 ⁵ / ₈	7 ³ / ₄	2	—	14-16d	6-10d	960	1735	1965	2120	
		HUCQ210-3-SDS	14	4 ⁵ / ₈	9	3	—	12- ¹ / ₄ "x2 ¹ / ₂ " SDS	6- ¹ / ₄ "x2 ¹ / ₂ " SDS	1805	3370	3570	3570
2x14	LUS210	18	1 ¹ / ₁₆	7 ¹³ / ₁₆	1 ³ / ₄	—	8-10d	4-10d	1005	1145	1305	1415	
	LU210	20	1 ¹ / ₁₆	7 ¹³ / ₁₆	1 ³ / ₄	—	10-16d	6-10dx1 ¹ / ₂	730	1190	1360	1470	
	U210	16	1 ¹ / ₁₆	7 ¹³ / ₁₆	2	—	10-16d	6-10dx1 ¹ / ₂	960	1240	1405	1445	
	HU214	14	1 ¹ / ₁₆	10 ¹ / ₈	2 ¹ / ₄	—	12-16d	6-10dx1 ¹ / ₂	980	1540	1735	1865	
	U214	16	1 ¹ / ₁₆	10	2	—	12-16d	8-10dx1 ¹ / ₂	960	1485	1685	1820	
	U210-2	16	3 ¹ / ₈	8 ¹ / ₂	2	—	14-16d	6-10d	960	1735	1965	2120	
DBL 2x14	LUS214-2	18	3 ¹ / ₈	10 ¹⁵ / ₁₆	2	—	10-16d	6-16d	1500	1805	2065	2235	
	HUS212-2/HUSC212-2	14	3 ¹ / ₈	10 ³ / ₄	2	—	10-16d	10-16d	3125	2275	2590	2795	
			14	3 ¹ / ₈	10 ⁹ / ₁₆	2 ¹ / ₂	Min	16-16d	6-10d	980	2050	2315	2490
			14	3 ¹ / ₈	10 ⁹ / ₁₆	2 ¹ / ₂	Max	22-16d	10-10d	1635	2820	3180	3425
			14	3 ¹ / ₈	12 ¹³ / ₁₆	2 ¹ / ₂	Min	18-16d	8-10d	1310	2305	2605	2800
			14	3 ¹ / ₈	12 ¹³ / ₁₆	2 ¹ / ₂	Max	24-16d	12-10d	1965	3075	3470	3735
		HUCQ210-2-SDS	14	2 ⁵ / ₈	9	3	—	12- ¹ / ₄ "x2 ¹ / ₂ " SDS	6- ¹ / ₄ "x2 ¹ / ₂ " SDS	1805	3370	3570	3570
TPL 2x14	U210-3	16	4 ⁵ / ₈	7 ³ / ₄	2	—	14-16d	6-10d	960	1735	1965	2120	
	HU214-3/HUC214-3	14	4 ¹ / ₁₆	12 ¹ / ₁₆	2 ¹ / ₂	Min	18-16d	8-10d	1310	2305	2605	2800	
			14	4 ¹ / ₁₆	12 ¹ / ₁₆	2 ¹ / ₂	Max	24-16d	12-10d	1735	3075	3470	3735
		HUCQ210-3-SDS	14	4 ⁵ / ₈	9	3	—	12- ¹ / ₄ "x2 ¹ / ₂ " SDS	6- ¹ / ₄ "x2 ¹ / ₂ " SDS	1805	3370	3570	3570
2x16	U214	16	1 ¹ / ₁₆	10	2	—	12-16d	8-10dx1 ¹ / ₂	960	1485	1685	1820	
	HU214	14	1 ¹ / ₁₆	10 ¹ / ₈	2 ¹ / ₄	—	12-16d	6-10dx1 ¹ / ₂	980	1540	1735	1865	
	HU216	14	1 ¹ / ₁₆	12 ¹⁵ / ₁₆	2 ¹ / ₄	—	18-16d	8-10dx1 ¹ / ₂	1310	2305	2415	2490	
	HUS212-2	14	3 ¹ / ₈	10 ³ / ₄	2	—	10-16d	10-16d	3125	2275	2590	2795	
DBL 2x16	HU216-2/HUC216-2	14	3 ¹ / ₈	13 ⁷ / ₈	2 ¹ / ₂	Min	20-16d	8-10d	1310	2565	2895	3110	
		14	3 ¹ / ₈	13 ⁷ / ₈	2 ¹ / ₂	Max	26-16d	12-10d	1735	3330	3760	4045	
TPL 2x16	HU216-3/HUC216-3	14	4 ¹ / ₁₆	13 ⁷ / ₈	2 ¹ / ₂	Min	20-16d	8-10d	1310	2565	2895	3110	
		14	4 ¹ / ₁₆	13 ⁷ / ₈	2 ¹ / ₂	Max	26-16d	12-10d	1735	3330	3760	4045	
3x4	U34	16	2 ⁹ / ₁₆	3 ³ / ₈	2	—	4-16d	2-10dx1 ¹ / ₂	230	495	560	605	
	HU34	14	2 ⁹ / ₁₆	3 ³ / ₈	2 ¹ / ₂	—	4-16d	2-10dx1 ¹ / ₂	325	515	580	620	
3x6	U36	16	2 ⁹ / ₁₆	5 ³ / ₈	2	—	8-16d	4-10dx1 ¹ / ₂	500	990	1125	1210	
	LUS36	18	2 ⁹ / ₁₆	5 ¹ / ₄	2	—	4-16d	4-16d	1000	880	1010	1090	
	HU36	14	2 ⁹ / ₁₆	5 ³ / ₈	2 ¹ / ₂	—	8-16d	4-10dx1 ¹ / ₂	525	1025	1155	1245	
3x8	U36	16	2 ⁹ / ₁₆	5 ³ / ₈	2	—	8-16d	4-10dx1 ¹ / ₂	500	990	1125	1210	
	HU38	14	2 ⁹ / ₁₆	7 ¹ / ₈	2 ¹ / ₂	—	10-16d	4-10dx1 ¹ / ₂	525	1280	1445	1555	
3x10	U310	16	2 ⁹ / ₁₆	8 ⁷ / ₈	2	—	14-16d	6-10dx1 ¹ / ₂	960	1735	1965	2120	
	LUS310	18	2 ⁹ / ₁₆	7 ¹ / ₄	2	—	6-16d	4-16d	1000	1125	1285	1390	
	HU310	14	2 ⁹ / ₁₆	8 ⁷ / ₈	2 ¹ / ₂	—	14-16d	6-10dx1 ¹ / ₂	790	1795	2025	2180	
3x12	U310	16	2 ⁹ / ₁₆	8 ⁷ / ₈	2	—	14-16d	6-10dx1 ¹ / ₂	960	1735	1965	2120	
	HU312	14	2 ⁹ / ₁₆	10 ⁹ / ₈	2 ¹ / ₂	—	16-16d	6-10dx1 ¹ / ₂	790	2050	2315	2490	
3x14	U314	16	2 ⁹ / ₁₆	10 ¹ / ₂	2	—	16-16d	6-10dx1 ¹ / ₂	960	1980	2245	2425	
	HU314	14	2 ⁹ / ₁₆	12 ³ / ₈	2 ¹ / ₂	—	18-16d	8-10dx1 ¹ / ₂	1310	2305	2605	2800	
3x16	U314	16	2 ⁹ / ₁₆	10 ¹ / ₂	2	—	16-16d	6-10dx1 ¹ / ₂	960	1980	2245	2425	
	HU316	14	2 ⁹ / ₁₆	14 ¹ / ₈	2 ¹ / ₂	—	20-16d	8-10dx1 ¹ / ₂	1310	2565	2895	3110	
4x4	LUS44	18	3 ¹ / ₁₆	3	2	—	4-16d	2-16d	380	680	780	845	
	U44	16	3 ¹ / ₁₆	2 ⁷ / ₈	2	—	4-16d	2-10d	320	495	560	605	
	HU44	14	3 ¹ / ₁₆	2 ⁷ / ₈	2 ¹ / ₂	—	4-16d	2-10d	325	515	580	620	
4x6	LUS46	18	3 ¹ / ₁₆	4 ³ / ₄	2	—	4-16d	4-16d	1000	880	1010	1090	
	U46	16	3 ¹ / ₁₆	4 ³ / ₈	2	—	8-16d	4-10d	640	990	1125	1210	
	HUS46/HUSC46	14	3 ¹ / ₁₆	5	2	—	4-16d	4-16d	1060	910	1035	1120	
			14	3 ¹ / ₁₆	5 ³ / ₁₆	2 ¹ / ₂	Min	8-16d	4-10d	655	1025	1155	1245
		HU46/HUC46	14	3 ¹ / ₁₆	5 ³ / ₁₆	2 ¹ / ₂	Max	12-16d	6-10d	980	1540	1735	1865
4x8	LUS46	18	3 ¹ / ₁₆	4 ³ / ₄	2	—	4-16d	4-16d	1000	880	1010	1090	
	U46	16	3 ¹ / ₁₆	4 ³ / ₈	2	—	8-16d	4-10d	640	990	1125	1210	
	LUS48	18	3 ¹ / ₁₆	6 ³ / ₄	2	—	6-16d	4-16d	1000	1125	1285	1390	
	HUS48/HUSC48	14	3 ¹ / ₁₆	6 ¹⁵ / ₁₆	2	—	6-16d	6-16d	1335	1365	1555	1680	
			14	3 ¹ / ₁₆	6 ¹³ / ₁₆	2 ¹ / ₂	Min	10-16d	4-10d	655	1280	1445	1555
	HU48/HUC48	14	3 ¹ / ₁₆	6 ¹⁵ / ₁₆	2 ¹ / ₂	Max	14-16d	6-10d	980	1795	2025	2180	

See footnotes on page 82.

FACE MOUNT HANGERS – SOLID SAWN LUMBER (SPF/HF)

These products are available with additional corrosion protection. Additional products on this page may also be available with this option, check with Simpson Strong-Tie for details.

Solid Sawn Joist Hangers

Joist Size	Model No.	Ga	Dimensions (in.)			Min/Max	Fasteners		SPF/HF Allowable Loads				
			W	H	B		Header	Joist	Uplift (160)	Floor (100)	Snow (115)	Roof (125)	
SAWN LUMBER SIZES													
4x10	LUS48	18	3 ⁹ / ₁₆	6 ³ / ₄	2	—	6-16d	4-16d	1000	1125	1285	1390	
	LUS410	18	3 ⁹ / ₁₆	8 ³ / ₄	2	—	8-16d	6-16d	1500	1565	1785	1935	
	U410	16	3 ⁹ / ₁₆	8 ⁵ / ₈	2	—	14-16d	6-10d	960	1735	1965	2120	
	HUS410/HUSC410	14	3 ⁹ / ₁₆	8 ¹ / ₁₆	2	—	8-16d	8-16d	2820	1820	2070	2240	
	HU410/HUC410	14	3 ⁹ / ₁₆	8 ⁵ / ₈	2 ¹ / ₂	Min	14-16d	6-10d	980	1795	2025	2180	
			14	3 ⁹ / ₁₆	8 ⁵ / ₈	2 ¹ / ₂	Max	18-16d	10-10d	1635	2305	2605	2800
	HUCQ410-SDS	14	3 ⁹ / ₁₆	9	3	—	12-SDS ¹ / ₄ "x2 ¹ / ₂ "	6-SDS ¹ / ₄ "x2 ¹ / ₂ "	1805	3370	3570	3570	
4x12	LUS410	18	3 ⁹ / ₁₆	8 ³ / ₄	2	—	8-16d	6-16d	1500	1565	1785	1935	
	LUS414	18	3 ⁹ / ₁₆	10 ³ / ₄	2	—	10-16d	6-16d	1500	1805	2065	2235	
	U410	16	3 ⁹ / ₁₆	8 ⁵ / ₈	2	—	14-16d	6-10d	960	1735	1965	2120	
	HUS410/HUSC410	14	3 ⁹ / ₁₆	8 ¹ / ₁₆	2	—	8-16d	8-16d	2820	1820	2070	2240	
	HUS412/HUSC412	14	3 ⁹ / ₁₆	10 ¹ / ₂	2	—	10-16d	10-16d	3125	2275	2590	2795	
	HU412/HUC412	14	3 ⁹ / ₁₆	10 ⁵ / ₁₆	2 ¹ / ₂	Min	16-16d	6-10d	980	2050	2315	2490	
			14	3 ⁹ / ₁₆	10 ⁵ / ₁₆	2 ¹ / ₂	Max	22-16d	10-10d	1635	2820	3180	3425
		HUCQ410-SDS	14	3 ⁹ / ₁₆	9	3	—	12-SDS ¹ / ₄ "x2 ¹ / ₂ "	6-SDS ¹ / ₄ "x2 ¹ / ₂ "	1805	3370	3570	3570
	HUCQ412-SDS	14	3 ⁹ / ₁₆	11	3	—	14-SDS ¹ / ₄ "x2 ¹ / ₂ "	6-SDS ¹ / ₄ "x2 ¹ / ₂ "	1805	3930	4005	4005	
4x14	LUS410	18	3 ⁹ / ₁₆	8 ³ / ₄	2	—	8-16d	6-16d	1500	1565	1785	1935	
	LUS414	18	3 ⁹ / ₁₆	10 ³ / ₄	2	—	10-16d	6-16d	1500	1805	2065	2235	
	U414	16	3 ⁹ / ₁₆	10	2	—	16-16d	6-10d	960	1980	2245	2425	
	HUS412/HUSC412	14	3 ⁹ / ₁₆	10 ¹ / ₂	2	—	10-16d	10-16d	3125	2275	2590	2795	
	HU414/HUC414	14	3 ⁹ / ₁₆	12 ⁵ / ₈	2 ¹ / ₂	Min	18-16d	8-10d	1310	2305	2605	2800	
			14	3 ⁹ / ₁₆	12 ⁵ / ₈	2 ¹ / ₂	Max	24-16d	12-10d	1965	3075	3470	3735
		HUCQ410-SDS	14	3 ⁹ / ₁₆	9	3	—	12-SDS ¹ / ₄ "x2 ¹ / ₂ "	6-SDS ¹ / ₄ "x2 ¹ / ₂ "	1805	3370	3570	3570
		HUCQ412-SDS	14	3 ⁹ / ₁₆	11	3	—	14-SDS ¹ / ₄ "x2 ¹ / ₂ "	6-SDS ¹ / ₄ "x2 ¹ / ₂ "	1805	3930	4005	4005
4x16	U414	16	3 ⁹ / ₁₆	10	2	—	16-16d	6-10d	960	1980	2245	2425	
	HUS412	14	3 ⁹ / ₁₆	10 ¹ / ₂	2	—	10-16d	10-16d	3125	2275	2590	2795	
	HU416/HUC416	14	3 ⁹ / ₁₆	13 ⁵ / ₈	2 ¹ / ₂	Min	20-16d	8-10d	1310	2565	2895	3110	
			14	3 ⁹ / ₁₆	13 ⁵ / ₈	2 ¹ / ₂	Max	26-16d	12-10d	1965	3330	3760	4045
		HUCQ412-SDS	14	3 ⁹ / ₁₆	11	3	—	14-SDS ¹ / ₄ "x2 ¹ / ₂ "	6-SDS ¹ / ₄ "x2 ¹ / ₂ "	1805	3930	4005	4005
6x6	U66	16	5 ¹ / ₂	5	2	—	8-16d	4-10d	640	990	1125	1210	
	HU66/HUC66	14	5 ¹ / ₂	4 ³ / ₁₆	2 ¹ / ₂	Min	8-16d	4-16d	775	1025	1155	1245	
			14	5 ¹ / ₂	4 ³ / ₁₆	2 ¹ / ₂	Max	12-16d	6-16d	1160	1540	1735	1865
6x8	U66	16	5 ¹ / ₂	5	2	—	8-16d	4-10d	640	990	1125	1210	
	HU68/HUC68	14	5 ¹ / ₂	5 ¹ / ₁₆	2 ¹ / ₂	Min	10-16d	4-16d	775	1280	1445	1555	
		14	5 ¹ / ₂	5 ¹ / ₁₆	2 ¹ / ₂	Max	14-16d	6-16d	1160	1795	2025	2180	
6x10	U610	16	5 ¹ / ₂	8 ¹ / ₂	2	—	14-16d	6-10d	960	1735	1965	2120	
	HU610/HUC610	14	5 ¹ / ₂	7 ⁵ / ₈	2 ¹ / ₂	Min	14-16d	6-16d	1160	1795	2025	2180	
			14	5 ¹ / ₂	7 ⁵ / ₈	2 ¹ / ₂	Max	18-16d	8-16d	1550	2305	2605	2800
		HUCQ610-SDS	14	5 ¹ / ₂	9	3	—	12-SDS ¹ / ₄ "x2 ¹ / ₂ "	6-SDS ¹ / ₄ "x2 ¹ / ₂ "	1815	3370	3875	4115
6x12	HU612/HUC612	14	5 ¹ / ₂	9 ⁵ / ₈	2 ¹ / ₂	Min	16-16d	6-16d	1160	2050	2315	2490	
			14	5 ¹ / ₂	9 ⁵ / ₈	2 ¹ / ₂	Max	22-16d	8-16d	1550	2820	3180	3425
		HUCQ610-SDS	14	5 ¹ / ₂	9	3	—	12-SDS ¹ / ₄ "x2 ¹ / ₂ "	6-SDS ¹ / ₄ "x2 ¹ / ₂ "	1815	3370	3875	4115
		HUCQ612-SDS	14	5 ¹ / ₂	11	3	—	14-SDS ¹ / ₄ "x2 ¹ / ₂ "	6-SDS ¹ / ₄ "x2 ¹ / ₂ "	1815	3825	3825	3825
6x14	HU614/HUC614	14	5 ¹ / ₂	11 ⁵ / ₈	2 ¹ / ₂	Min	18-16d	8-16d	1550	2305	2605	2800	
			14	5 ¹ / ₂	11 ⁵ / ₈	2 ¹ / ₂	Max	24-16d	12-16d	2325	3075	3470	3735
		HUCQ610-SDS	14	5 ¹ / ₂	9	3	—	12-SDS ¹ / ₄ "x2 ¹ / ₂ "	6-SDS ¹ / ₄ "x2 ¹ / ₂ "	1815	3370	3875	4115
		HUCQ612-SDS	14	5 ¹ / ₂	11	3	—	14-SDS ¹ / ₄ "x2 ¹ / ₂ "	6-SDS ¹ / ₄ "x2 ¹ / ₂ "	1815	3825	3825	3825
6x16	HU616/HUC616	14	5 ¹ / ₂	12 ¹ / ₁₆	2 ¹ / ₂	Min	20-16d	8-16d	1550	2565	2895	310	
			14	5 ¹ / ₂	12 ¹ / ₁₆	2 ¹ / ₂	Max	26-16d	12-16d	2325	3330	3760	4045
	HUCQ612-SDS	14	5 ¹ / ₂	11	3	—	14-SDS ¹ / ₄ "x2 ¹ / ₂ "	6-SDS ¹ / ₄ "x2 ¹ / ₂ "	1815	3825	3825	3825	
8x8	HU88/HUC88	14	7 ¹ / ₂	6 ⁵ / ₈	2 ¹ / ₂	Min	10-16d	4-16d	775	1280	1445	1555	
			14	7 ¹ / ₂	6 ⁵ / ₈	2 ¹ / ₂	Max	14-16d	6-16d	1160	1795	2025	2180
8x10	HU810/HUC810	14	7 ¹ / ₂	8 ⁵ / ₈	2 ¹ / ₂	Min	14-16d	6-16d	1160	1795	2025	2180	
			14	7 ¹ / ₂	8 ⁵ / ₈	2 ¹ / ₂	Max	18-16d	8-16d	1550	2305	2605	2800
8x12	HU812/HUC812	14	7 ¹ / ₂	10 ¹ / ₈	2 ¹ / ₂	Min	16-16d	6-16d	1160	2050	2315	2490	
			14	7 ¹ / ₂	10 ¹ / ₈	2 ¹ / ₂	Max	22-16d	8-16d	1550	2820	3180	3425
8x14	HU814/HUC814	14	7 ¹ / ₂	11 ⁵ / ₈	2 ¹ / ₂	Min	18-16d	8-16d	1550	2305	2605	2800	
			14	7 ¹ / ₂	11 ⁵ / ₈	2 ¹ / ₂	Max	24-16d	12-16d	2325	3075	3470	3735
8x16	HU816/HUC816	14	7 ¹ / ₂	13 ⁵ / ₈	2 ¹ / ₂	Min	20-16d	8-16d	1550	2565	2895	310	
			14	7 ¹ / ₂	13 ⁵ / ₈	2 ¹ / ₂	Max	26-16d	12-16d	2325	3330	3760	4045

- Uplift loads apply to 10d and 16d header fasteners. Uplift loads have been increased for wind or earthquake loading with no further increase allowed. Reduce where other loads govern.
- 10d commons or 16d sinkers may be used instead of the specified 16d at 0.84 of the table load value.
- 16d sinkers may be used instead of the specified 10d commons with no load reduction. (16d sinkers are not acceptable for HDG applications.)
- MIN nailing quantity and load values—fill all round holes;
MAX nailing quantity and load values—fill all round and triangle holes.
- Truss chord cross-grain tension may limit allowable loads in accordance with ANSI/TPI 1-2007. Simpson Strong-Tie® Connector Selector™ Software includes the evaluation of cross-grain tension in its hanger allowable loads. For additional information, contact Simpson Strong-Tie.
- NAILS:** 16d = 0.162" dia. x 3¹/₂" long, 10d = 0.148" dia. x 3" long, 10dx1¹/₂ = 0.148" dia. x 1¹/₂" long. See pages 22-23 for other nail sizes and information.

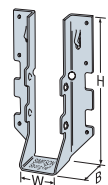

FACE MOUNT HANGERS – ROUGH LUMBER (DF & SP)

Joist Size	Model No.	Ga	Dimensions (in.)			Fasteners		DF/SP Allowable Loads				Code Ref.
			W	H	B	Header	Joist	Uplift (160)	Floor (100)	Snow (115)	Roof (125)	
SAWN LUMBER SIZES												
2x4(R)	LU24R-18	18	2	3 ¹¹ / ₁₆	1 ¹ / ₂	4-16d	2-10dx1 ¹ / ₂	265	565	640	695	IL8
	U24R	16	2	3 ⁵ / ₈	2	4-16d	2-10dx1 ¹ / ₂	265	575	655	705	I7, F6, L17
2x6(R)	LU26R-18	18	2	4 ⁹ / ₁₆	1 ¹ / ₂	6-16d	4-10dx1 ¹ / ₂	565	845	965	1040	IL8
	U26R	16	2	5 ⁵ / ₈	2	8-16d	4-10dx1 ¹ / ₂	585	1150	1305	1410	I7, F6, L17
2x8(R)	LU28R-18	18	2	6 ⁵ / ₈	1 ¹ / ₂	8-16d	6-10dx1 ¹ / ₂	865	1125	1285	1335	IL8
	U26R	16	2	5 ⁵ / ₈	2	8-16d	4-10dx1 ¹ / ₂	585	1150	1305	1410	I7, F6, L17
2x10(R)	LU210R-18	18	2	7 ⁷ / ₁₆	2	10-16d	6-10dx1 ¹ / ₂	850	1410	1605	1735	IL8
	U210R	16	2	9 ¹ / ₈	2	14-16d	6-10dx1 ¹ / ₂	1110	2015	2285	2465	I7, F6, L17
2x12(R)	U210R	16	2	9 ¹ / ₈	2	14-16d	6-10dx1 ¹ / ₂	1110	2015	2285	2465	
2x14(R)	U210R	16	2	9 ¹ / ₈	2	14-16d	6-10dx1 ¹ / ₂	1110	2015	2285	2465	
4x4(R)	U44R	16	4	2 ⁵ / ₈	2	4-16d	2-16d	440	575	655	705	
4x6(R)	U46R	16	4	4 ⁵ / ₈	2	8-16d	4-16d	885	1150	1305	1410	
4x8(R)	U46R	16	4	4 ⁵ / ₈	2	8-16d	4-16d	885	1150	1305	1410	
4x10(R)	U410R	16	4	8 ¹ / ₈	2	14-16d	6-16d	1115	2015	2285	2465	
4x12(R)	U410R	16	4	8 ¹ / ₈	2	14-16d	6-16d	1115	2015	2285	2465	
4x14(R)	U410R	16	4	8 ¹ / ₈	2	14-16d	6-16d	1115	2015	2285	2465	
6x6(R)	U66R	16	6	5	2	8-16d	4-16d	885	1150	1305	1410	
6x8(R)	U66R	16	6	5	2	8-16d	4-16d	885	1150	1305	1410	
6x10(R)	U610R	16	6	8 ¹ / ₂	2	14-16d	6-16d	1115	2015	2285	2465	
6x12(R)	U610R	16	6	8 ¹ / ₂	2	14-16d	6-16d	1115	2015	2285	2465	
6x14(R)	U610R	16	6	8 ¹ / ₂	2	14-16d	6-16d	1115	2015	2285	2465	

Solid Sawn Joist Hangers

FACE MOUNT HANGERS – ROUGH LUMBER (SPF/HF)

Joist Size	Model No.	Ga	Dimensions (in.)			Fasteners		SPF/HF Allowable Loads			
			W	H	B	Header	Joist	Uplift (160)	Floor (100)	Snow (115)	Roof (125)
SAWN LUMBER SIZES											
2x4(R)	LU24R-18	18	2	3 ¹¹ / ₁₆	1 ¹ / ₂	4-16d	2-10dx1 ¹ / ₂	230	485	550	595
	U24R	16	2	3 ⁵ / ₈	2	4-16d	2-10dx1 ¹ / ₂	230	495	560	605
2x6(R)	LU26R-18	18	2	4 ⁹ / ₁₆	1 ¹ / ₂	6-16d	4-10dx1 ¹ / ₂	490	725	825	895
	U26R	16	2	5 ⁵ / ₈	2	8-16d	4-10dx1 ¹ / ₂	500	990	1125	1210
2x8(R)	LU28R-18	18	2	6 ⁵ / ₈	1 ¹ / ₂	8-16d	6-10dx1 ¹ / ₂	745	970	1100	1145
	U26R	16	2	5 ⁵ / ₈	2	8-16d	4-10dx1 ¹ / ₂	500	990	1125	1210
2x10(R)	LU210R-18	18	2	7 ⁷ / ₁₆	2	10-16d	6-10dx1 ¹ / ₂	730	1210	1380	1490
	U210R	16	2	9 ¹ / ₈	2	14-16d	6-10dx1 ¹ / ₂	960	1735	1965	2120
2x12(R)	U210R	16	2	9 ¹ / ₈	2	14-16d	6-10dx1 ¹ / ₂	960	1735	1965	2120
2x14(R)	U210R	16	2	9 ¹ / ₈	2	14-16d	6-10dx1 ¹ / ₂	960	1735	1965	2120
4x4(R)	U44R	16	4	2 ⁵ / ₈	2	4-16d	2-16d	380	495	560	605
4x6(R)	U46R	16	4	4 ⁵ / ₈	2	8-16d	4-16d	760	990	1125	1210
4x8(R)	U46R	16	4	4 ⁵ / ₈	2	8-16d	4-16d	760	990	1125	1210
4x10(R)	U410R	16	4	8 ¹ / ₈	2	14-16d	6-16d	960	1735	1965	2120
4x12(R)	U410R	16	4	8 ¹ / ₈	2	14-16d	6-16d	960	1735	1965	2120
4x14(R)	U410R	16	4	8 ¹ / ₈	2	14-16d	6-16d	960	1735	1965	2120
6x6(R)	U66R	16	6	5	2	8-16d	4-16d	760	990	1125	1210
6x8(R)	U66R	16	6	5	2	8-16d	4-16d	760	990	1125	1210
6x10(R)	U610R	16	6	8 ¹ / ₂	2	14-16d	6-16d	960	1735	1965	2120
6x12(R)	U610R	16	6	8 ¹ / ₂	2	14-16d	6-16d	960	1735	1965	2120
6x14(R)	U610R	16	6	8 ¹ / ₂	2	14-16d	6-16d	960	1735	1965	2120

- Uplift loads apply to 10d and 16d header fasteners. Uplift loads have been increased for wind or earthquake loading with no further increase allowed. Reduce where other loads govern.
- 10d commons or 16d sinkers may be used instead of the specified 16d at 0.84 of the table load value.
- 16d sinkers may be used instead of the specified 10d commons with no load reduction.

- DF/SP loads can be used for SCL that has fastener holding capacity of Doug Fir.
- HU's can be ordered in rough sizes at full table loads. Add "X" to the model designation ex: HU28X and specify rough width or height. Maximum width 8".
- NAILS:** 16d = 0.162" dia. x 3¹/₂" long, 10d = 0.148" dia. x 3" long, 10dx1¹/₂ = 0.148" dia. x 1¹/₂" long. See pages 22-23 for other nail sizes and information.

CODES: See page 12 for Code Reference Key Chart.

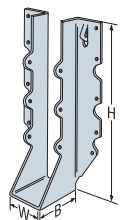

TOP FLANGE HANGERS JB/JBA/LB/LBAZ/BA/B/HHB Joist, Beam and Purlin Hangers



This product is preferable to similar connectors because of
a) easier installation, b) higher loads, c) lower installed cost,
or a combination of these features.

The new, next-generation LBAZ and JBA hangers provide higher loads for 2x10, 2x12 and 2x14 members in 14 gauge and 18 gauge steel, respectively. The new nail locations on the JBA enable effective use with nailers.

The B and BA hangers are cost effective hangers featuring min/max joist nailing option. Min Nailing featuring Positive Angle Nailing targets moderate load conditions whereas the Max Nailing generates capacities for higher loads. The unique two level embossment provides added stiffness to the top flange.

See tables on pages 87-91. See Hanger Options on pages 233-243

for hanger modifications, which may result in reduced loads.

MATERIAL: See tables, pages 87-91.

FINISH: BA, JB, JBA, LB, LBAZ and B—Galvanized; HHB—all saddle hangers and all welded sloped and special hangers—Simpson Strong-Tie® gray paint. BA, LB, B and HHB may be ordered hot-dip galvanized, specify HDG.

INSTALLATION: • Use specified fasteners. See General Notes and nailer table notes.

- LBAZ, BA, B and HHB may also be welded to steel headers with weld size to match material thickness (approximate thickness shown). The minimum required weld to the top flanges is 1/8" x 2" (1/8" x 1 1/16" for LBAZ) fillet weld to each side of each top flange tab for 14 and 12 gauge and 3/16" x 2" fillet weld to each side of each top flange tab for 7 gauge. Distribute the weld equally on both top flanges. Welding cancels the top and face nailing requirements. Consult the code for special considerations when welding galvanized steel. The area should be well-ventilated (see page 17 for welding information). Weld on applications produce the maximum allowable down load listed. For uplift loads refer to technical bulletin T-WELDUPLFT.
- Ledgers must be evaluated for each application separately. Check TF dimension, nail length and nail location on ledger.
- Refer to technical bulletin T-SLOPEJST for information regarding load reductions on selected hangers which can be used without modification to support joists which have shallow slopes (≤3/4:12).

OPTIONS: B and HHB

- Other widths are available; specify W dimension (the minimum W dimension is 1 1/16" for B and 3/4" for HHB).
- See Hanger Options, pages 233-243. BA, JB, JBA, LB and LBAZ hangers cannot be modified. Use LBV as an alternative for the JBA/LBAZ.

CODES: See page 12 for Code Reference Key Chart.

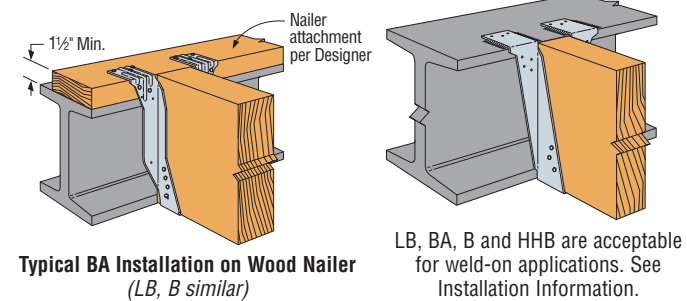
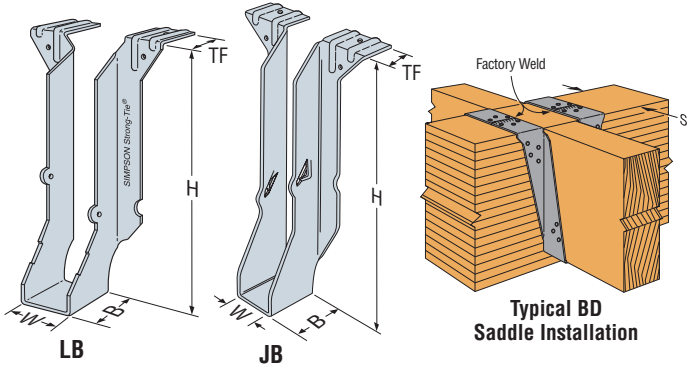
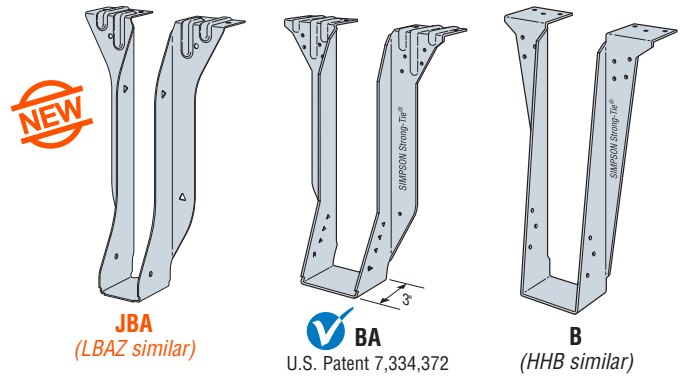

Nailer Table⁵

Model No.	Nailer	Top Flange Nailing	Joist Nailing	Allowable Loads		
				Uplift ¹ (160)	DF/SP	SPF/HF
JB210A JB212A JB214A	2x 3x	6-10dx1 1/2 6-16dx2 1/2	2-10dx1 1/2 2-10dx1 1/2	315 315	1265 1290	965 —
LB26	2x	4-10dx1 1/2	2-10dx1 1/2	—	850	—
LB28	2x	4-10dx1 1/2	2-10dx1 1/2	—	915	—
LB210AZ LB212AZ LB214AZ	2x 3x	6-10dx1 1/2 6-16dx2 1/2	2-10dx1 1/2 2-10dx1 1/2	375 375	1265 1290	1065 —
LB216	2x	4-10dx1 1/2	2-10dx1 1/2	—	1150	—
BA	2x	10-10dx1 1/2	2-10dx1 1/2	265 ³	2220	1755
	2-2x	14-10d	2-10dx1 1/2	265 ³	2695	2235
	3x	14-16dx2 1/2	2-10dx1 1/2	265 ³	3230	—
	4x	14-16d	2-10dx1 1/2	265 ³	3230	—
B	2-2x	14-10d	6-10dx1 1/2	710 ⁴	3615	2770
	3x	14-16dx2 1/2	6-10dx1 1/2	830 ⁴	3725	—
	4x	14-16d	6-10dx1 1/2	830 ⁴	3800	—

1. Uplift values are for DF/SP nailers only. Refer to technical bulletin T-NAILERUPLFT for SPF values.
2. For joist members 2 1/2" or wider, 16dx2 1/2" joist nails should be installed for additional uplift loads on the 3x and 4x nailer applications of 970 lbs. and 1010 lbs. respectively.
3. If joist nailing is increased to (8)-10dx1 1/2, higher uplift loads are allowed. See technical bulletin T-NAILERUPLFT.
4. If joist nailing is increased to (6)-16dx2 1/2, higher uplift loads are allowed for joist members at least 2 1/2" wide. See technical bulletin T-NAILERUPLFT.
5. Attachment of nailer to supporting member is by the Designer.

TOP FLANGE HANGERS JB/JBA/LB/LBAZ/BA/B/HHB Joist, Beam and Purlin Hangers

B Series With Various Header Applications

Joist or Purlin Size	Model No.	Ga	Dimensions				Fasteners		Allowable Loads by Header Type and Fastener					Code Ref.
			W	H	B	TF	Header	Joist	Uplift (160)	LVL	PSL	DF/SP	SPF/HF	
2x	JB26	18	1 ⁵ / ₁₆	see pages 87-89	1 ¹ / ₂	1 ⁵ / ₁₆	4-10d	2-prong	—	—	—	1040	815	I10, L11, F16
	JB28				1 ¹ / ₂	1 ⁵ / ₁₆	4-10d	2-prong	—	—	—	1050	820	
	JB210A JB212A JB214A				2	1 ⁵ / ₁₆	6-16d	2-10dx1 ¹ / ₂	315	—	—	1685	1190	160
					6-10d	2-10dx1 ¹ / ₂	315	—	—	1015	1015			
	2x				LB26	14	1 ⁵ / ₁₆	see pages 87-89	1 ¹ / ₂	1 ⁵ / ₁₆	4-16d	2-10dx1 ¹ / ₂	290	—
LB28		1 ¹ / ₂	1 ⁵ / ₁₆	4-16d	2-10dx1 ¹ / ₂				290	—	—	1270	790	
LB210AZ LB212AZ LB214AZ		2	1 ⁵ / ₁₆	6-16d	2-10dx1 ¹ / ₂				380	—	—	1865	1330	170
		6-10d	2-10dx1 ¹ / ₂	380	—				—	1220	1220			
4x		BA Min.	14	3 ⁵ / ₁₆	see pages 87-89				3	1 ⁵ / ₁₆	16-16d	2-10dx1 ¹ / ₂	265	3230
		16-10d				2-10dx1 ¹ / ₂	265	4015			3705	3435	2665	
	BA Max.	16-16d				2-10dx1 ¹ / ₂	1170	3555			3630	3625	2465	
		16-10d				2-10dx1 ¹ / ₂	1170	4715			4320	3800	2665	
3x, 4x	B	12	see pages 87-89	see pages 87-89	2 ¹ / ₂	2 ¹ / ₂	14-16d	6-10dx1 ¹ / ₂	990	3575	3195	3625	2190	
							14-10d	6-10dx1 ¹ / ₂	990	4135	3355	3800	2650	

- Uplift loads are based on DF/SP lumber and have been increased for wind or earthquake loading with no further increase allowed. Reduce where other loads govern.
- For SPF use 0.86 x DF/SP uplift load.
- Where noted for single-ply joist hangers use 6-10dx1¹/₂" nails.
- NAILS:** 16d = 0.162" dia. x 3¹/₂" long, 10d = 0.148" dia. x 3" long, 10dx1¹/₂" = 0.148" dia. x 1¹/₂" long. See pages 22-23 for other nail sizes and information.

Solid Sawn Joist Hangers

HUTF/HUSTF Heavy Duty and Double Shear Joist Hangers

See dimensions, material, loads on table pages. HUSTF has the double shear nailing advantage—distributing the joist load through two points on each nail for greater strength.

FINISH: Galvanized. See Corrosion Information, pages 13-15.

INSTALLATION:

- Use all specified fasteners. See General Notes.
- Not acceptable for nailer or welded applications; see W and B hangers.
- HUTF—The minimum header or ledger size that can be used with this hanger is 3¹/₂".
- HUSTF—With 3x carrying members, use 16dx2¹/₂" nails into the header and 16d commons into the joist.

OPTIONS:

- HUTF rough beam sizes are available by special order.
- See Hanger Options on pages 233-243 for slope and/or skewed hangers.
- Available with flanges turned in (2-2x and 4x only for HUSCTF. 2⁵/₁₆" or greater for HUCTF).

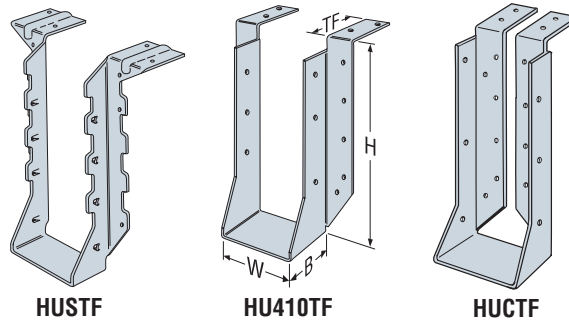

Some model configurations may differ from those shown. Production models have projected seats. Square cut seats may be ordered. Contact Simpson Strong-Tie for details.

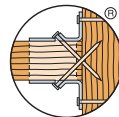

Double Shear Nailing Top View

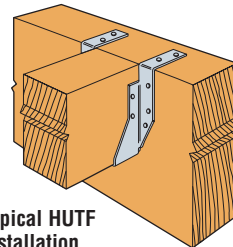

Typical HUTF Installation

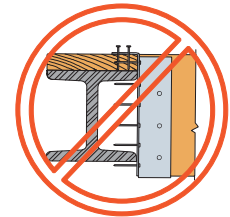

Nailer application is NOT acceptable. Fasteners cannot be installed

TOP FLANGE HANGERS W/WPU/WNP/WM/WMU/HW/HWU/GLT/HGLT

The W, WPU, HWU and HW series purlin hangers offer the greatest design flexibility and versatility. WMs are designed for use on standard 8" grouted masonry block wall construction.

MATERIAL: See tables on pages 87-91.

FINISH: Simpson Strong-Tie® gray paint; hot-dip galvanized available; specify HDG, contact Simpson Strong-Tie.

INSTALLATION: • Use all specified fasteners.

- H dimensions are sized to account for normal joist shrinkage. W dimensions are for dressed timber widths.
- Hangers may be welded to steel headers with weld size to match material thickness (approximate thickness shown) 1/8" for W, 3/16" for WNP/WPU and 1/4" for HW/HWU, by 1 1/2" fillet welds located at each end of the top flange (see page 17 for welding information). Weld-on applications produce maximum allowable load listed. For uplift loads refer to technical bulletin T-WELDUPLFT (HWU and WPU hangers only).
- GLT/HGLT may be welded to steel headers, see page 104 for requirements.
- Hangers can support multi-ply carried members; the individual members must be secured together to work as a single unit before installation into the hanger.
- WM—two 16d duplex nails must be installed into the top flange and embedded into the grouted wall. Verify that the grouted wall can take the required fasteners specified in the table.
- Embed WM into block with a minimum of one course above and one course below the top flange with one #5 vertical rebar minimum 24" long in each cell. Minimum grout strength is 2000 psi.
- **OPTIONS:** • Refer to technical bulletin T-SLOPEJST for information regarding load reductions on selected hangers which can be used without modification to support joists which have shallow slopes (≤3/4:12).
- See Hanger Options, pages 233-243 for hanger modifications and associated load reductions.
- Some model configurations may differ from those shown. Contact Simpson Strong-Tie for details.

CODES: See page 12 for Code Reference Key Chart.

Model	Nailer	Top Flange Nailing	Uplift ¹ (160)	Allowable Down Loads		
				DF/SP	SPF/HF	LSL
W	2x	2-10dx1 1/2	—	1600	1600	—
	2-2x	2-10d	—	1665	1665	—
	3x	2-16dx2 1/2	—	1765	—	—
	4x	2-10d	—	2200	—	—
WP and WNP	2x	2-10dx1 1/2	—	2525	2500	3375
	2-2x	2-10d	—	3255	3255	—
	3x	2-16dx2 1/2	—	3000	2510	3375
	4x	2-10d	—	3255	3255	—
WPU	2-2x	7-10d	700	3255	—	—
	3x	7-16dx2 1/2	970	3000	—	—
	4x	7-16d	1095	3255	—	—
HW	2-2x	4-10d	—	4860	—	—
	3x	4-16dx2 1/2	—	4845	—	—
	4x	4-16d	—	5285	—	—
HWU	2-2x	8-16dx2 1/2	710	5430	—	—
	3x	8-16dx2 1/2	970	5430	—	—
	4x	8-16d	1160	5430	—	—

NAILER TABLE

The table indicates the maximum allowable loads for W, WNP and HW hangers used on wood nailers. Nailers are wood members attached to the top of a steel I-beam, concrete or masonry wall.

1. Uplift value for the HWU hanger is for depths ≤18" and are for DF/SP values only. Refer to uplift values in table below for taller depths.
2. Attachment of nailer to supporting member is the responsibility of the Designer.

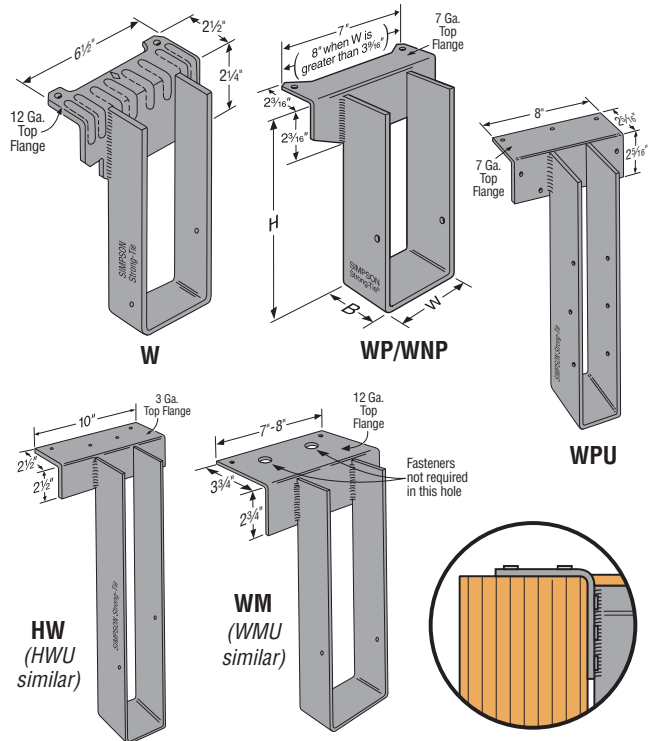

Eased Edge
Flatten edge of header to match top flange radius.

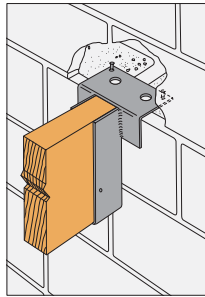

Typical WM Mid-Wall Installation
See pages 173-174 for models and information.

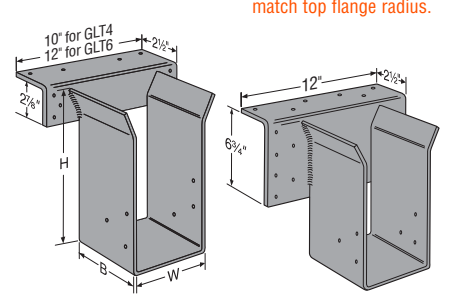

GLT (fasteners included)
See pages 104-105 for GLT and HGLT information.

HGLT (fasteners included)

W SERIES WITH VARIOUS HEADER APPLICATIONS

Model	Joist		Fasteners			Allowable Loads Header Type							Code Ref.	
	Width	Depth	Top	Face	Joist	Uplift (160)	LVL	PSL	LSL	DF/SP	SPF/HF	I-Joist		Masonry
W	1 1/2 to 4	3 1/2 to 30	2-10dx1 1/2	—	2-10dx1 1/2	—	1635	1740	—	1600	1415	—	—	170
	1 1/2 to 4	3 1/2 to 30	2-10d	—	2-10dx1 1/2	—	2150	2020	—	2200	1435	—	—	I10, F9, L14
	1 1/2 to 4	3 1/2 to 30	2-16d	—	2-10dx1 1/2	—	2335	1950	2335	1765	1435	—	—	
WM	1 1/2 to 7 1/2	3 1/2 to 30	2-16d DPLX	—	2-10dx1 1/2	—	MID-WALL INSTALLATION⁴						4175	L16
	1 1/2 to 7 1/2	3 1/2 to 30	2-1/4x1 3/4 Titens	—	2-10dx1 1/2	—	TOP OF WALL INSTALLATION						3380	L11
WMU	1 1/2 to 7 1/2	9 to 28	2-16d DPLX	4-1/4x1 3/4 Titens	6-10dx1 1/2	625	MID-WALL INSTALLATION⁴						4175	170
	1 1/2 to 7 1/2	9 to 28	2-1/4x1 3/4 Titens	4-1/4x1 3/4 Titens	6-10dx1 1/2	545	TOP OF WALL INSTALLATION						3380	
WP/WNP	1 1/2 to 7 1/2	3 1/2 to 30	2-10dx1 1/2	—	2-10dx1 1/2	—	2865	3250	—	2500	2000	2030	—	I10, I19, F9, F18, L11, L14
	1 1/2 to 7 1/2	3 1/2 to 30	2-10d	—	2-10dx1 1/2	—	2525	3250	3650	3255	2525	—	—	
	1 1/2 to 7 1/2	3 1/2 to 30	2-16d	—	2-10dx1 1/2	—	3635	3320	3650	3255	2600	—	—	
WPU/ WNPU	1 1/2 to 5 1/2	7 1/2 to 18	3-16d	4-16d	6-10dx1 1/2	1095	4700	4880	3650	4165	4165	—	—	I10, I19, F9, F18, L11, L14
	1 1/2 to 5 1/2	18 1/2 to 28	3-16d	4-16d	6-10dx1 1/2	390	4700	4880	3650	4165	4165	—	—	
HW	1 1/2 to 7 1/2	3 1/2 to 32	4-10d	—	2-10dx1 1/2	—	3100	4000	—	5285	3100	—	—	I10, I19, F9, F18, L11, L14
	1 1/2 to 7 1/2	3 1/2 to 32	4-16d	—	2-10dx1 1/2	—	5100	4000	4500	5285	3665	—	—	
HWU	1 1/2 to 3 1/2	9 to 18	4-16d	4-16d	6-10dx1 1/2	1160	6335	5500	5535	6335	5415	—	—	I10, I19, F9, F18, L11, L14
	1 1/2 to 3 1/2	18 1/2 to 28	4-16d	4-16d	6-10dx1 1/2	965	6335	5500	5535	6335	5415	—	—	
	1 1/2 to 3 1/2	28 1/2 to 32	4-16d	4-16d	8-10dx1 1/2	985	6335	5500	5535	6335	5415	—	—	
	4 1/2 to 7	9 to 18	4-16d	4-16d	6-10dx1 1/2	1160	6000	5500	5535	6000	5415	—	—	
	4 1/2 to 7	18 1/2 to 28	4-16d	4-16d	6-10dx1 1/2	965	6000	5500	5535	6000	5415	—	—	
4 1/2 to 7	28 1/2 to 32	4-16d	4-16d	8-10dx1 1/2	985	6000	5500	5535	6000	5415	—	—		

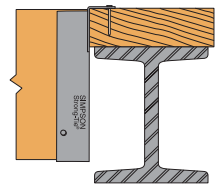

Installation on Wood Nailer

1. Code values are based on DF/SP header species.
2. WMU, WPU and HWU uplift loads have been increased for wind or earthquake loading with no further increase allowed. Reduce where other loads govern.
3. For hanger heights exceeding the joist height, the allowable load is 0.50 of the table load.
4. Mid-wall Installation requires minimum of one grouted course above and below the hanger.
5. **NAILS:** 16d = 0.162" dia. x 3 1/2" long, 10d = 0.148" dia. x 3" long, 10dx1 1/2 = 0.148" dia. x 1 1/2" long. See pages 22-23 for other nail sizes and information.

TOP FLANGE HANGERS – SOLID SAWN LUMBER (DF/SP)

DON'T FEEL LIKE SIFTING THROUGH THIS TABLE? Visit www.strongtie.com/software to learn more about our new Joist Hanger Selector software.

These products are available with additional corrosion protection. Additional products on this page may also be available with this option, check with Simpson Strong-Tie for details.

Joist or Purlin Size	Model No.	Ga	Dimensions				Fasteners		DF/SP Allowable Loads				Installed Cost Index (ICI)	Code Ref.
			W	H	B	TF	Header	Joist	Uplift (160)	Floor (100)	Snow (115)	Roof (125)		
SAWN LUMBER SIZES														
2x4	HU24TF	12	1 ⁵ / ₁₆	3 ⁵ / ₁₆	2 ¹ / ₄	2 ¹ / ₂	6-16d	2-10dx1 ¹ / ₂	295	2090	2100	2100	Lowest	I10, F9, L11
DBL 2x4	HU24-2TF	12	3 ¹ / ₂	3 ⁵ / ₁₆	2 ¹ / ₂	2 ¹ / ₂	8-16d	2-10d	375	2600	2600	2600	Lowest	
2x6	JB26	18	1 ⁵ / ₁₆	5 ⁵ / ₁₆	1 ¹ / ₂	1 ⁵ / ₁₆	4-10d	2 PRONG	—	1040	1040	1040	Lowest	
	LB26	14	1 ⁵ / ₁₆	5 ⁵ / ₁₆	1 ¹ / ₂	1 ¹ / ₂	4-16d	2-10dx1 ¹ / ₂	290	1380	1380	1380	+117%	
	HU26TF	12	1 ⁵ / ₁₆	5 ⁵ / ₁₆	2 ¹ / ₄	2 ¹ / ₂	10-16d	4-10dx1 ¹ / ₂	590	2275	2330	2335	+568%	
	W26	12	1 ⁵ / ₁₆	5 ⁵ / ₁₆	2 ¹ / ₂	2 ¹ / ₂	2-10d	2-10dx1 ¹ / ₂	—	2200	2200	2200	+890%	
DBL 2x6	HUS26-2TF	14	3 ¹ / ₈	5 ⁵ / ₈	2	1 ³ / ₄	6-16d	4-16d	1235	2820	3000	3000	Lowest	
	WNP26-2	12	3 ¹ / ₈	5 ⁵ / ₈	2 ¹ / ₂	2 ³ / ₁₆	2-10d	2-10d	—	3255	3255	3255	+33%	
	HU26-2TF	12	3 ¹ / ₈	5 ⁵ / ₈	2 ¹ / ₂	2 ¹ / ₂	10-16d	4-10d	750	3725	3900	3900	+87%	
2x8	JB28	18	1 ⁵ / ₁₆	7 ¹ / ₄	1 ¹ / ₂	1 ⁵ / ₁₆	4-10d	2 PRONG	—	1050	1050	1050	Lowest	
	LB28	14	1 ⁵ / ₁₆	7 ¹ / ₄	1 ¹ / ₂	1 ¹ / ₂	4-16d	2-10dx1 ¹ / ₂	290	1270	1270	1270	+98%	
	HU28TF	12	1 ⁵ / ₁₆	7 ⁵ / ₈	2 ¹ / ₄	2 ¹ / ₂	10-16d	4-10dx1 ¹ / ₂	590	2335	2335	2335	+563%	
	W28	12	1 ⁵ / ₁₆	7 ⁵ / ₈	2 ¹ / ₂	2 ¹ / ₂	2-10d	2-10dx1 ¹ / ₂	—	2200	2200	2200	+570%	
DBL 2x8	HUS28-2TF	14	3 ¹ / ₈	7 ¹ / ₄	2	1 ⁵ / ₈	8-16d	6-16d	1550	3455	3720	3895	Lowest	
	WNP28-2	12	3 ¹ / ₈	7 ⁵ / ₈	2 ¹ / ₂	2 ³ / ₁₆	2-10d	2-10d	—	3255	3255	3255	+16%	
	HU28-2TF	12	3 ¹ / ₈	7 ⁵ / ₈	2 ¹ / ₂	2 ¹ / ₂	12-16d	4-10d	750	3900	3900	3900	+75%	
2x10	JB210A	18	1 ⁵ / ₁₆	9 ⁵ / ₁₆	2	1 ⁵ / ₁₆	6-16d	2-10dx1 ¹ / ₂	315	1685	1685	1685	—	160
	LB210AZ	14	1 ⁵ / ₁₆	9 ⁵ / ₁₆	2	1 ⁵ / ₁₆	6-16d	2-10dx1 ¹ / ₂	380	1865	1865	1865	—	170
	HU210TF	12	1 ⁵ / ₁₆	9 ⁵ / ₁₆	2 ¹ / ₄	2 ¹ / ₂	12-16d	4-10dx1 ¹ / ₂	590	2335	2335	2335	+359%	
	W210	12	1 ⁵ / ₁₆	9 ⁵ / ₁₆	2 ¹ / ₂	2 ¹ / ₂	2-10d	2-10dx1 ¹ / ₂	—	2200	2200	2200	+360%	
DBL 2x10	HUS210-2TF	14	3 ¹ / ₈	9 ¹ / ₄	2	1 ¹ / ₂	10-16d	8-16d	2590	3585	3925	4155	Lowest	
	WNP210-2	12	3 ¹ / ₈	9 ⁵ / ₈	2 ¹ / ₂	2 ³ / ₁₆	2-10d	2-10d	—	3255	3255	3255	+9%	
	HU210-2TF	12	3 ¹ / ₈	9 ⁵ / ₈	2 ¹ / ₂	2 ¹ / ₂	14-16d	6-10d	1125	4170	4170	4170	+67%	
TPL 2x10	HU210-3TF	12	4 ¹¹ / ₁₆	9 ⁵ / ₈	2 ¹ / ₂	2 ¹ / ₂	14-16d	6-16d	1325	4150	4150	4150	Lowest	
2x12	JB212A	18	1 ⁵ / ₁₆	11 ⁵ / ₈	2	1 ⁵ / ₁₆	6-16d	2-10dx1 ¹ / ₂	315	1685	1685	1685	—	160
	LB212AZ	14	1 ⁵ / ₁₆	11 ⁵ / ₈	2	1 ⁵ / ₁₆	6-16d	2-10dx1 ¹ / ₂	380	1865	1865	1865	—	170
	W212	12	1 ⁵ / ₁₆	11	2 ¹ / ₂	2 ¹ / ₂	2-10d	2-10dx1 ¹ / ₂	—	2200	2200	2200	+317%	
	HU212TF	12	1 ⁵ / ₁₆	11	2 ¹ / ₄	2 ¹ / ₂	14-16d	6-10dx1 ¹ / ₂	885	2335	2335	2335	+339%	
DBL 2x12	HUS212-2TF	14	3 ¹ / ₈	11 ⁵ / ₈	2	2 ¹ / ₄	10-16d	8-16d	2000	4435	4535	4605	Lowest	
	WNP212-2	12	3 ¹ / ₈	11	2 ¹ / ₂	2 ³ / ₁₆	2-10d	2-10d	—	3255	3255	3255	+12%	
	HU212-2TF	12	3 ¹ / ₈	11	2 ¹ / ₂	2 ¹ / ₂	16-16d	6-10d	1125	4325	4660	4880	+48%	
TPL 2x12	HU212-3TF	12	4 ¹¹ / ₁₆	11	2 ¹ / ₂	2 ¹ / ₂	16-16d	6-16d	1325	4550	4885	5105	Lowest	
2x14	JB214A	18	1 ⁵ / ₁₆	13 ⁵ / ₈	2	1 ⁵ / ₁₆	6-16d	2-10dx1 ¹ / ₂	315	1685	1685	1685	—	160
	LB214AZ	14	1 ⁵ / ₁₆	13 ⁵ / ₈	2	1 ⁵ / ₁₆	6-16d	2-10dx1 ¹ / ₂	380	1865	1865	1865	—	170
	W214	12	1 ⁵ / ₁₆	13	2 ¹ / ₂	2 ¹ / ₂	2-10d	2-10dx1 ¹ / ₂	—	2200	2200	2200	+188%	
	HU214TF	12	1 ⁵ / ₁₆	13	2 ¹ / ₄	2 ¹ / ₂	16-16d	6-10dx1 ¹ / ₂	885	2660	2745	2800	+189%	
DBL 2x14	HUS214-2TF	14	3 ¹ / ₈	13 ⁵ / ₈	2	2 ¹ / ₄	12-16d	8-16d	2590	4435	4535	4605	Lowest	
	WNP214-2	12	3 ¹ / ₈	13	2 ¹ / ₂	2 ³ / ₁₆	2-10d	2-10d	—	3255	3255	3255	+2%	
	HU214-2TF	12	3 ¹ / ₈	13	2 ¹ / ₂	2 ¹ / ₂	18-16d	8-10d	1500	4335	4335	4335	+33%	
TPL 2x14	HU214-3TF	12	4 ¹¹ / ₁₆	13	2 ¹ / ₂	2 ¹ / ₂	18-16d	8-16d	1765	4835	5050	5050	Lowest	
2x16	LB216	14	1 ⁵ / ₁₆	15 ⁵ / ₈	2	1 ¹ / ₂	4-16d	2-10dx1 ¹ / ₂	290	1425	1425	1425	Lowest	
	W216	12	1 ⁵ / ₁₆	15	2 ¹ / ₂	2 ¹ / ₂	2-10d	2-10dx1 ¹ / ₂	—	2200	2200	2200	+122%	
	HU216TF	12	1 ⁵ / ₁₆	15	2 ¹ / ₄	2 ¹ / ₂	18-16d	8-10dx1 ¹ / ₂	1180	2845	2955	3030	+199%	
DBL 2x16	WNP216-2	12	3 ¹ / ₈	15	2 ¹ / ₂	2 ³ / ₁₆	2-10d	2-10d	—	3255	3255	3255	Lowest	
	HU216-2TF	12	3 ¹ / ₈	15	2 ¹ / ₂	2 ¹ / ₂	20-16d	8-10d	1500	4335	4335	4335	+34%	

- N54A fasteners are supplied with hangers.
- 16d sinkers may be used where 10d commons are called out with no load reduction.
- Uplift loads are based on DF/SP lumber and have been increased for wind or earthquake loading with no further increase allowed. For normal loading applications such as cantilever construction refer to Simpson Strong-Tie® Connector Selector™ software or conservatively divide the uplift load by 1.6. For SPF use 0.86 x DF/SP uplift load.
- NAILS:** 16d = 0.162" dia. x 3¹/₂" long, 10d = 0.148" dia. x 3" long, 10dx1¹/₂ = 0.148" dia. x 1¹/₂" long. See pages 22-23 for other nail sizes and information.

CODES: See page 12 for Code Reference Key Chart.

*Installed Cost Index not available on these models.

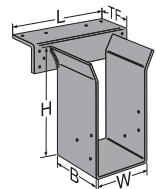

TOP FLANGE HANGERS – SOLID SAWN LUMBER (DF/SP)

These products are available with additional corrosion protection. Additional products on this page may also be available with this option, check with Simpson Strong-Tie for details.

Joist or Purlin Size	Model No.	Ga	Dimensions				Fasteners		DF/SP Allowable Loads				Installed Cost Index (ICI)	Code Ref.	
			W	H	B	TF	Header	Joist	Uplift (160)	Floor (100)	Snow (115)	Roof (125)			
SAWN LUMBER SIZES															
TPL 2x16	HU216-3TF	12	4 ¹¹ / ₁₆	15	2½	2½	20-16d	8-16d	1765	5050	5050	5050	Lowest	I10, F9, L11	
3x4	HU34TF	12	2 ⁹ / ₁₆	3 ⁷ / ₁₆	2½	2½	8-16d	2-10dx1½	295	2600	2600	2600	*		
3x6	W36	12	2 ⁹ / ₁₆	5%	2	2½	2-10d	2-10dx1½	—	2200	2200	2200	*		
	HU36TF	12	2 ⁹ / ₁₆	5%	2½	2½	10-16d	4-10dx1½	590	3725	3900	3900	*		
3x8	W38	12	2 ⁹ / ₁₆	7%	2	2½	2-10d	2-10dx1½	—	2200	2200	2200	*		
	HU38TF	12	2 ⁹ / ₁₆	7%	2½	2½	12-16d	4-10dx1½	590	3900	3900	3900	*		
3x8	B38	12	2 ⁹ / ₁₆	7%	2½	2½	14-16d	6-16dx2½	1010	3800	3800	3800	*		I19, L14
	W310	12	2 ⁹ / ₁₆	9%	2	2½	2-10d	2-10dx1½	—	2200	2200	2200	*		
3x10	HU310TF	12	2 ⁹ / ₁₆	9%	2½	2½	14-16d	6-10dx1½	885	4170	4170	4170	*		I10, F9, L11
	B310	12	2 ⁹ / ₁₆	9%	2½	2½	14-16d	6-16dx2½	1010	3800	3800	3800	*		I19, F21, L14
3x12	WNP312	12	2 ⁹ / ₁₆	11	2½	2 ³ / ₁₆	2-10d	2-10dx1½	—	3255	3255	3255	*		I10, F9, L11
	HU312TF	12	2 ⁹ / ₁₆	11	2½	2½	16-16d	6-10dx1½	885	4335	4335	4335	*		
3x12	B312	12	2 ⁹ / ₁₆	11	2½	2½	14-16d	6-16dx2½	1010	3800	3800	3800	*		I19, F21, L14
	WNP314	12	2 ⁹ / ₁₆	13	2½	2 ³ / ₁₆	2-10d	2-10dx1½	—	3255	3255	3255	*		I10, F9, L11
3x14	HU314TF	12	2 ⁹ / ₁₆	13	2½	2½	18-16d	8-10dx1½	1180	4335	4335	4335	*		
	B314	12	2 ⁹ / ₁₆	13	2½	2½	14-16d	6-16dx2½	1010	3800	3800	3800	*		I19, F21, L14
3x16	WNP316	12	2 ⁹ / ₁₆	15	2½	2 ³ / ₁₆	2-10d	2-10dx1½	—	3255	3255	3255	*	I10, F9, L11	
	HU316TF	12	2 ⁹ / ₁₆	15	2½	2½	20-16d	8-10dx1½	1180	4335	4335	4335	*		
B316	12	2 ⁹ / ₁₆	15	2½	2½	14-16d	6-16dx2½	1010	3800	3800	3800	*	I19, F21, L14		
4x3	HU43TF	12	3 ⁹ / ₁₆	3	2½	2½	8-16d	2-10d	330	2600	2600	2600	*	I10, F9, L11	
4x4	HU44TF	12	3 ⁹ / ₁₆	3 ⁷ / ₁₆	2½	2½	8-16d	2-10d	375	2600	2600	2600	Lowest		
4x6	HUS46TF	14	3 ⁹ / ₁₆	5%	2	1½	6-16d	4-16d	1235	2700	2890	3000	Lowest		
	W46	12	3 ⁹ / ₁₆	5%	2½	2½	2-10d	2-10d	—	2200	2200	2200	+12%		
	HU46TF	12	3 ⁹ / ₁₆	5%	2½	2½	10-16d	4-10d	750	3165	3165	3165	+28%		
	HW46	11	3 ⁹ / ₁₆	5%	2½	2½	4-10d	2-10d	—	5285	5285	5285	+83%		
4x8	BA48 (Min)	14	3 ⁹ / ₁₆	7½	3	2½	16-16d	2-10dx1½	265	3435	3435	3435	Lowest		I19, F21, L14
	BA48 (Max)	14	3 ⁹ / ₁₆	7½	3	2½	16-16d	8-10dx1½	1170	3800	3800	3800	+7%		
	HUS48TF	14	3 ⁹ / ₁₆	7¼	2	1 ¹¹ / ₁₆	8-16d	6-16d	1550	3225	3495	3670	+33%		I10, IL12, F9, L11
	B48	12	3 ⁹ / ₁₆	7½	2½	2½	14-16d	6-16d	1010	3800	3800	3800	+35%		I19, F21, L14
	W48	12	3 ⁹ / ₁₆	7½	2½	2½	2-10d	2-10d	—	2200	2200	2200	+54%		I10, F9, L11
	HU48TF	12	3 ⁹ / ₁₆	7½	2½	2½	12-16d	4-10d	750	3500	3500	3500	+95%		
HW48	11	3 ⁹ / ₁₆	7½	2½	2½	4-10d	2-10d	—	5285	5285	5285	+130%			
4x10	BA410 (Min)	14	3 ⁹ / ₁₆	9%	3	2½	16-16d	2-10dx1½	265	3435	3435	3435	Lowest		I19, F21
	BA410 (Max)	14	3 ⁹ / ₁₆	9%	3	2½	16-16d	8-10dx1½	1170	3800	3800	3800	+7%		
	HUS410TF	14	3 ⁹ / ₁₆	9¼	2	1½	10-16d	8-16d	2590	3365	3710	3935	+21%		I10, F9, L11
	B410	12	3 ⁹ / ₁₆	9%	2½	2½	14-16d	6-16d	1010	3800	3800	3800	+35%	I19, F21, L14	
	W410	12	3 ⁹ / ₁₆	9%	2½	2½	2-10d	2-10d	—	2200	2200	2200	+49%	I10, F9, L11	
	HU410TF	12	3 ⁹ / ₁₆	9%	2½	2½	14-16d	6-10d	1125	4150	4150	4150	+86%		
	HW410	11	3 ⁹ / ₁₆	9%	2½	2½	4-10d	2-10d	—	5285	5285	5285	+130%		
	GLT4	7	3 ⁹ / ₁₆	7½ Min.	5	2½	10-N54A	6-N54A	1865	7000	7000	7000	*	I19, F18, L14	
HGLT4	7	3 ⁹ / ₁₆	7½ Min.	6	2½	18-N54A	6-N54A	1865	12750	12750	12750	*	I19, L14		
4x12	BA412 (Min)	14	3 ⁹ / ₁₆	11	3	2½	16-16d	2-10dx1½	265	3435	3435	3435	Lowest	I19, F21, L14	
	BA412 (Max)	14	3 ⁹ / ₁₆	11	3	2½	16-16d	8-10dx1½	1170	3800	3800	3800	+6%		
	HUS412TF	14	3 ⁹ / ₁₆	11½	2	2	10-16d	8-16d	2000	4420	4760	4990	+14%	I10, F9	
	B412	12	3 ⁹ / ₁₆	11	2½	2½	14-16d	6-16d	1010	3800	3800	3800	+27%	I19, F21, L14	
	WNP412	12	3 ⁹ / ₁₆	11	2½	2 ³ / ₁₆	2-10d	2-10d	—	3255	3255	3255	+32%	I10, F9, L11	
	HU412TF	12	3 ⁹ / ₁₆	11	2½	2½	16-16d	6-10d	1125	4550	4885	5105	+84%		
	HW412	11	3 ⁹ / ₁₆	11	2½	2½	4-10d	2-10d	—	5285	5285	5285	+115%		
	HHB412	7	3 ⁹ / ₁₆	11	3	2½	4-N54A	2-N54A	650	4185	4185	4185	+174%	I19, F18, L14	
GLT4	7	3 ⁹ / ₁₆	7½ Min.	5	2½	10-N54A	6-N54A	1865	7000	7000	7000	*			
HGLT4	7	3 ⁹ / ₁₆	7½ Min.	6	2½	18-N54A	6-N54A	1865	12750	12750	12750	*	I19, L14		

TOP FLANGE HANGERS – SOLID SAWN LUMBER (DF/SP)

These products are available with additional corrosion protection. Additional products on this page may also be available with this option, check with Simpson Strong-Tie for details.

Joist or Purlin Size	Model No.	Ga	Dimensions				Fasteners		DF/SP Allowable Loads				Installed Cost Index (ICI)	Code Ref.
			W	H	B	TF	Header	Joist	Uplift (160)	Floor (100)	Snow (115)	Roof (125)		
SAWN LUMBER SIZES														
4x14	HUS414TF	14	3 ¹ / ₁₆	13 ¹ / ₈	2	2	12-16d	8-16d	2160	4765	5100	5100	Lowest	I10, F9, L11
	B414	12	3 ¹ / ₁₆	13	2 ¹ / ₂	2 ¹ / ₂	14-16d	6-16d	1010	3800	3800	3800	+8%	I19, F21, L14
	WNP414	12	3 ¹ / ₁₆	13	2 ¹ / ₂	2 ¹ / ₁₆	2-10d	2-10d	—	3255	3255	3255	+13%	I10, F9, L11
	HU414TF	12	3 ¹ / ₁₆	13	2 ¹ / ₂	2 ¹ / ₂	18-16d	8-10d	1500	4830	5050	5050	+89%	
	HW414	11	3 ¹ / ₁₆	13	2 ¹ / ₂	2 ¹ / ₂	4-10d	2-10d	—	5285	5285	5285	+108%	
	HHB414	7	3 ¹ / ₁₆	13	3	2 ¹ / ₂	6-N54A	4-N54A	1300	5135	5135	5135	+150%	I19, F18, L14
	GLT4	7	3 ¹ / ₁₆	7 ¹ / ₂ Min.	5	2 ¹ / ₂	10-N54A	6-N54A	1865	7000	7000	7000	*	
HGLT4	7	3 ¹ / ₁₆	7 ¹ / ₂ Min.	6	2 ¹ / ₂	18-N54A	6-N54A	1865	12750	12750	12750	*		
4x16	WNP416	12	3 ¹ / ₁₆	15	2 ¹ / ₂	2 ¹ / ₁₆	2-10d	2-10d	—	3255	3255	3255	Lowest	I10, F9, L11
	B416	12	3 ¹ / ₁₆	15	2 ¹ / ₂	2 ¹ / ₂	14-16d	6-16d	1010	3800	3800	3800	+23%	I19, F21, L14
	HU416TF	12	3 ¹ / ₁₆	15	2 ¹ / ₂	2 ¹ / ₂	20-16d	8-10d	1500	5050	5050	5050	+81%	I10, F9, L11
	HW416	11	3 ¹ / ₁₆	15	2 ¹ / ₂	2 ¹ / ₂	4-10d	2-10d	—	5285	5285	5285	+108%	
	HHB416	7	3 ¹ / ₁₆	15	3	2 ¹ / ₂	6-N54A	4-N54A	1300	5135	5135	5135	+109%	
	GLT4	7	3 ¹ / ₁₆	7 ¹ / ₂ Min.	5	2 ¹ / ₂	10-N54A	6-N54A	1865	7000	7000	7000	*	I19, F18, L14
	HGLT4	7	3 ¹ / ₁₆	7 ¹ / ₂ Min.	6	2 ¹ / ₂	18-N54A	6-N54A	1865	12750	12750	12750	*	
6x6	WNP66	12	5 ¹ / ₂	5 ³ / ₈	2 ¹ / ₂	2 ¹ / ₁₆	3-10d	2-10d	—	3255	3255	3255	*	I10, F9, L11
	HU66TF	12	5 ¹ / ₂	5 ³ / ₈	2 ¹ / ₂	2 ¹ / ₂	10-16d	4-16d	885	3165	3165	3165	*	
	HW66	11	5 ¹ / ₂	5 ³ / ₈	2 ¹ / ₂	2 ¹ / ₂	4-10d	2-10d	—	5285	5285	5285	*	
6x8	WNP68	12	5 ¹ / ₂	7 ¹ / ₈	2 ¹ / ₂	2 ¹ / ₁₆	3-10d	2-10d	—	3255	3255	3255	*	I10, F9, L11
	HU68TF	12	5 ¹ / ₂	7 ¹ / ₈	2 ¹ / ₂	2 ¹ / ₂	12-16d	4-16d	885	3500	3500	3500	*	
	HHB68	7	5 ¹ / ₂	7 ¹ / ₈	3	2 ¹ / ₂	4-N54A	2-N54A	650	4185	4185	4185	*	
	HW68	11	5 ¹ / ₂	7 ¹ / ₈	2 ¹ / ₂	2 ¹ / ₂	4-10d	2-10d	—	5285	5285	5285	*	
6x10	WNP610	12	5 ¹ / ₂	9 ¹ / ₈	2 ¹ / ₂	2 ¹ / ₁₆	3-10d	2-10d	—	3255	3255	3255	*	I19, F21, L14
	B610	12	5 ¹ / ₂	9 ¹ / ₈	2 ¹ / ₂	2 ¹ / ₂	14-16d	6-16d	1010	3800	3800	3800	*	
	HHB610	7	5 ¹ / ₂	9 ¹ / ₈	3	2 ¹ / ₂	4-N54A	2-N54A	650	4185	4185	4185	*	
	HU610TF	12	5 ¹ / ₂	9 ¹ / ₈	2 ¹ / ₂	2 ¹ / ₂	14-16d	6-16d	1325	4150	4150	4150	*	
	HW610	11	5 ¹ / ₂	9 ¹ / ₈	2 ¹ / ₂	2 ¹ / ₂	4-10d	2-10d	—	5285	5285	5285	*	
	GLT6	7	5 ¹ / ₁₆	7 ¹ / ₂ Min.	5	2 ¹ / ₂	10-N54A	6-N54A	1865	7000	7000	7000	*	
	HGLT6	7	5 ¹ / ₁₆	7 ¹ / ₂ Min.	6	2 ¹ / ₂	18-N54A	6-N54A	1865	12750	12750	12750	*	
6x12	HW612	11	5 ¹ / ₂	11	2 ¹ / ₂	2 ¹ / ₂	4-10d	2-10d	—	5285	5285	5285	*	I10, F9, L11
	B612	12	5 ¹ / ₂	11	2 ¹ / ₂	2 ¹ / ₂	14-16d	6-16d	1010	3800	3800	3800	*	
	HHB612	7	5 ¹ / ₂	11	3	2 ¹ / ₂	10-N54A	6-N54A	1950	6235	6235	6235	*	
	HU612TF	12	5 ¹ / ₂	11	2 ¹ / ₂	2 ¹ / ₂	16-16d	6-16d	1325	4550	4885	5105	*	
	GLT6	7	5 ¹ / ₁₆	7 ¹ / ₂ Min.	5	2 ¹ / ₂	10-N54A	6-N54A	1865	7000	7000	7000	*	
	HGLT6	7	5 ¹ / ₁₆	7 ¹ / ₂ Min.	6	2 ¹ / ₂	18-N54A	6-N54A	1865	12750	12750	12750	*	
6x14	HW614	11	5 ¹ / ₂	13	2 ¹ / ₂	2 ¹ / ₂	4-10d	2-10d	—	5285	5285	5285	*	I10, F9, L11
	B614	12	5 ¹ / ₂	13	2 ¹ / ₂	2 ¹ / ₂	14-16d	6-16d	1010	3800	3800	3800	*	
	HHB614	7	5 ¹ / ₂	13	3	2 ¹ / ₂	10-N54A	6-N54A	1950	6235	6235	6235	*	
	HU614TF	12	5 ¹ / ₂	13	2 ¹ / ₂	2 ¹ / ₂	18-16d	8-16d	1765	4830	5200	5450	*	
	GLT6	7	5 ¹ / ₁₆	7 ¹ / ₂ Min.	5	2 ¹ / ₂	10-N54A	6-N54A	1865	7000	7000	7000	*	
	HGLT6	7	5 ¹ / ₁₆	7 ¹ / ₂ Min.	6	2 ¹ / ₂	18-N54A	6-N54A	1865	12750	12750	12750	*	
6x16	HW616	11	5 ¹ / ₂	15	2 ¹ / ₂	2 ¹ / ₂	4-10d	2-10d	—	5285	5285	5285	*	I10, F9, L11
	B616	12	5 ¹ / ₂	15	2 ¹ / ₂	2 ¹ / ₂	14-16d	6-16d	1010	3800	3800	3800	*	
	HHB616	7	5 ¹ / ₂	15	3	2 ¹ / ₂	10-N54A	6-N54A	1950	6235	6235	6235	*	
	HU616TF	12	5 ¹ / ₂	15	2 ¹ / ₂	2 ¹ / ₂	20-16d	8-16d	1765	5105	5520	5795	*	
	GLT6	7	5 ¹ / ₁₆	7 ¹ / ₂ Min.	5	2 ¹ / ₂	10-N54A	6-N54A	1865	7000	7000	7000	*	
	HGLT6	7	5 ¹ / ₁₆	7 ¹ / ₂ Min.	6	2 ¹ / ₂	18-N54A	6-N54A	1865	12750	12750	12750	*	
8x6	HW86	7	7 ¹ / ₂	5 ³ / ₈	2 ¹ / ₂	2 ¹ / ₂	4-10d	2-10d	—	5285	5285	5285	*	I10, F9, L11
	HW88	7	7 ¹ / ₂	7 ¹ / ₈	2 ¹ / ₂	2 ¹ / ₂	4-10d	2-10d	—	5285	5285	5285	*	
	HW810	7	7 ¹ / ₂	9 ¹ / ₈	2 ¹ / ₂	2 ¹ / ₂	4-10d	2-10d	—	5285	5285	5285	*	
8x12	HW812	7	7 ¹ / ₂	11	2 ¹ / ₂	2 ¹ / ₂	4-10d	2-10d	—	5285	5285	5285	*	I19, F18, L14
	HHB812	7	7 ¹ / ₂	11	3	2 ¹ / ₂	10-N54A	6-N54A	1950	6235	6235	6235	*	
8x14	HW814	7	7 ¹ / ₂	13	2 ¹ / ₂	2 ¹ / ₂	4-10d	2-10d	—	5285	5285	5285	*	I10, F9, L11
	HHB814	7	7 ¹ / ₂	13	3	2 ¹ / ₂	10-N54A	6-N54A	1950	6235	6235	6235	*	
8x16	HW816	7	7 ¹ / ₂	15	2 ¹ / ₂	2 ¹ / ₂	4-10d	2-10d	—	5285	5285	5285	*	I10, F9, L11
	HHB816	7	7 ¹ / ₂	15	3	2 ¹ / ₂	10-N54A	6-N54A	1950	6235	6235	6235	*	

Solid Sawn Joist Hangers

C-C-2015 © 2015 SIMPSON STRONG-TIE COMPANY INC. PRINTED 12/14

TOP FLANGE HANGERS – SOLID SAWN LUMBER (SPF/HF)

These products are available with additional corrosion protection. Additional products on this page may also be available with this option, check with Simpson Strong-Tie for details.

Solid Sawn Joist Hangers

Joist or Purlin Size	Model No.	Ga	Dimensions (in.)				Fasteners		SPF/HF Allowable Loads			
			W	H	B	TF	Header	Joist	Uplift (160)	Floor (100)	Snow (115)	Roof (125)
SAWN LUMBER SIZES												
2x4	HU24TF	12	1 ¹ / ₆	3 ³ / ₁₆	2 ¹ / ₄	2 ¹ / ₂	6-16d	2-10dx1 ¹ / ₂	350	930	930	930
2x6	JB26	18	1 ¹ / ₆	5 ³ / ₈	1 ¹ / ₂	1 ¹ / ₂	4-10d	2 PRONG	—	815	815	815
	LB26	14	1 ¹ / ₆	5 ³ / ₈	1 ¹ / ₂	1 ¹ / ₂	4-16d	2-10dx1 ¹ / ₂	325	860	860	860
	HU26TF	12	1 ¹ / ₆	5 ³ / ₈	2 ¹ / ₄	2 ¹ / ₂	10-16d	4-10dx1 ¹ / ₂	695	1000	1000	1000
	W26	12	1 ¹ / ₆	5 ³ / ₈	2 ¹ / ₂	2 ¹ / ₂	2-10d	2-10dx1 ¹ / ₂	—	1435	1435	1435
DBL 2x6	WNP26-2	12	3 ¹ / ₈	5 ³ / ₈	2 ¹ / ₂	2 ³ / ₁₆	2-10d	2-10d	—	2525	2525	2525
2x8	JB28	18	1 ¹ / ₆	7 ¹ / ₄	1 ¹ / ₂	1 ¹ / ₂	4-10d	2 PRONG	—	820	820	820
	LB28	14	1 ¹ / ₆	7 ¹ / ₄	1 ¹ / ₂	1 ¹ / ₂	4-16d	2-10dx1 ¹ / ₂	325	790	790	790
	W28	12	1 ¹ / ₆	7 ¹ / ₈	2 ¹ / ₂	2 ¹ / ₂	2-10d	2-10dx1 ¹ / ₂	—	1435	1435	1435
DBL 2x8	WNP28-2	12	3 ¹ / ₈	7 ¹ / ₈	2 ¹ / ₂	2 ³ / ₁₆	2-10d	2-10d	—	2525	2525	2525
2x10	JB210A	18	1 ¹ / ₆	9 ³ / ₁₆	2	1 ¹ / ₆	6-16d	2-10dx1 ¹ / ₂	270	1190	1190	1190
	LB210AZ	14	1 ¹ / ₆	9 ³ / ₁₆	2	1 ¹ / ₆	6-16d	2-10dx1 ¹ / ₂	325	1330	1330	1330
	W210	12	1 ¹ / ₆	9 ¹ / ₈	2 ¹ / ₂	2 ¹ / ₂	2-10d	2-10dx1 ¹ / ₂	—	1435	1435	1435
DBL 2x10	WNP210-2	12	3 ¹ / ₈	9 ¹ / ₈	2 ¹ / ₂	2 ³ / ₁₆	2-10d	2-10d	—	2525	2525	2525
2x12	JB212A	18	1 ¹ / ₆	11 ¹ / ₈	2	1 ¹ / ₆	6-16d	2-10dx1 ¹ / ₂	270	1190	1190	1190
	LB212AZ	14	1 ¹ / ₆	11 ¹ / ₈	2	1 ¹ / ₆	6-16d	2-10dx1 ¹ / ₂	325	1330	1330	1330
	W212	12	1 ¹ / ₆	11	2 ¹ / ₂	2 ¹ / ₂	2-10d	2-10dx1 ¹ / ₂	—	1435	1435	1435
DBL 2x12	WNP212-2	12	3 ¹ / ₈	11	2 ¹ / ₂	2 ³ / ₁₆	2-10d	2-10d	—	2525	2525	2525
2x14	JB214A	18	1 ¹ / ₆	13 ³ / ₈	2	1 ¹ / ₆	6-16d	2-10dx1 ¹ / ₂	270	1190	1190	1190
	LB214AZ	14	1 ¹ / ₆	13 ³ / ₈	2	1 ¹ / ₆	6-16d	2-10dx1 ¹ / ₂	325	1330	1330	1330
	W214	12	1 ¹ / ₆	13	2 ¹ / ₂	2 ¹ / ₂	2-10d	2-10dx1 ¹ / ₂	—	1435	1435	1435
DBL 2x14	WNP214-2	12	3 ¹ / ₈	13	2 ¹ / ₂	2 ³ / ₁₆	2-10d	2-10d	—	2525	2525	2525
2x16	LB216	14	1 ¹ / ₆	15 ¹ / ₈	2	1 ¹ / ₂	4-16d	2-10dx1 ¹ / ₂	325	945	945	945
	W216	12	1 ¹ / ₆	15	2 ¹ / ₂	2 ¹ / ₂	2-10d	2-10dx1 ¹ / ₂	—	1435	1435	1435
DBL 2x16	WNP216-2	12	3 ¹ / ₈	15	2 ¹ / ₂	2 ³ / ₁₆	2-10d	2-10d	—	2525	2525	2525
TPL 2x16	HU216-3TF	12	4 ¹ / ₁₆	15	2 ¹ / ₂	2 ¹ / ₂	20-16d	8-16d				
3x6	W36	12	2 ¹ / ₆	5 ³ / ₈	2	2 ¹ / ₂	2-10d	2-10dx1 ¹ / ₂	—	1435	1435	1435
	W38	12	2 ¹ / ₆	7 ¹ / ₈	2	2 ¹ / ₂	2-10d	2-10dx1 ¹ / ₂	—	1435	1435	1435
3x8	B38	12	2 ¹ / ₆	7 ¹ / ₈	2 ¹ / ₂	2 ¹ / ₂	14-16d	6-16dx2 ¹ / ₂	865	2650	2650	2650
	W310	12	2 ¹ / ₆	9 ¹ / ₈	2	2 ¹ / ₂	2-10d	2-10dx1 ¹ / ₂	—	1435	1435	1435
3x10	B310	12	2 ¹ / ₆	9 ¹ / ₈	2 ¹ / ₂	2 ¹ / ₂	14-16d	6-16dx2 ¹ / ₂	865	2650	2650	2650
	WNP312	12	2 ¹ / ₆	11	2 ¹ / ₂	2 ³ / ₁₆	2-10d	2-10dx1 ¹ / ₂	—	2525	2525	2525
3x12	B312	12	2 ¹ / ₆	11	2 ¹ / ₂	2 ¹ / ₂	14-16d	6-16dx2 ¹ / ₂	865	2650	2650	2650
	WNP314	12	2 ¹ / ₆	13	2 ¹ / ₂	2 ³ / ₁₆	2-10d	2-10dx1 ¹ / ₂	—	2525	2525	2525
3x14	B314	12	2 ¹ / ₆	13	2 ¹ / ₂	2 ¹ / ₂	14-16d	6-16dx2 ¹ / ₂	865	2650	2650	2650
	WNP316	12	2 ¹ / ₆	15	2 ¹ / ₂	2 ³ / ₁₆	2-10d	2-10dx1 ¹ / ₂	—	2525	2525	2525
3x16	B316	12	2 ¹ / ₆	15	2 ¹ / ₂	2 ¹ / ₂	14-16d	6-16dx2 ¹ / ₂	865	2650	2650	2650

1. Uplift loads have been increased for wind or earthquake loading with no further increase allowed. For normal loading applications such as cantilever construction, refer to Simpson Strong-Tie® Connector Selector™ software or conservatively divide the uplift load by 1.6.

2. 16d sinkers may be used where 10d commons are called out with no load reduction.

3. **NAILS:** 16d = 0.162" dia. x 3¹/₂" long, 10d = 0.148" dia. x 3" long, 10dx1¹/₂ = 0.148" dia. x 1¹/₂" long. See pages 22-23 for other nail sizes and information.

TOP FLANGE HANGERS – SOLID SAWN LUMBER (SPF/HF)

These products are available with additional corrosion protection. Additional products on this page may also be available with this option, check with Simpson Strong-Tie for details.

Joist or Purlin Size	Model No.	Ga	Dimensions (in.)				Fasteners		SPF/HF Allowable Loads			
			W	H	B	TF	Header	Joist	Uplift (160)	Floor (100)	Snow (115)	Roof (125)
SAWN LUMBER SIZES												
4x6	W46	12	3 ⁹ / ₁₆	5 ³ / ₈	2 ¹ / ₂	2 ¹ / ₂	2-10d	2-10d	—	1435	1435	1435
	HW46	11	3 ⁹ / ₁₆	5 ³ / ₈	2 ¹ / ₂	2 ¹ / ₂	4-10d	2-10d	—	3235	3235	3235
4x8	BA48 (Min)	14	3 ⁹ / ₁₆	7 ¹ / ₈	3	2 ¹ / ₂	16-16d	2-10dx1 ¹ / ₂	225	2665	2665	2665
	BA48 (Max)	14	3 ⁹ / ₁₆	7 ¹ / ₈	3	2 ¹ / ₂	16-16d	8-10dx1 ¹ / ₂	1005	2665	2665	2665
	B48	12	3 ⁹ / ₁₆	7 ¹ / ₈	2 ¹ / ₂	2 ¹ / ₂	14-16d	6-16d	865	2650	2650	2650
	W48	12	3 ⁹ / ₁₆	7 ¹ / ₈	2 ¹ / ₂	2 ¹ / ₂	2-10d	2-10d	—	1435	1435	1435
	HW48	11	3 ⁹ / ₁₆	7 ¹ / ₈	2 ¹ / ₂	2 ¹ / ₂	4-10d	2-10d	—	3235	3235	3235
4x10	BA410 (Min)	14	3 ⁹ / ₁₆	9 ¹ / ₈	3	2 ¹ / ₂	16-16d	2-10dx1 ¹ / ₂	225	2665	2665	2665
	BA410 (Max)	14	3 ⁹ / ₁₆	9 ¹ / ₈	3	2 ¹ / ₂	16-16d	8-10dx1 ¹ / ₂	1005	2665	2665	2665
	B410	12	3 ⁹ / ₁₆	9 ¹ / ₈	2 ¹ / ₂	2 ¹ / ₂	14-16d	6-16d	865	2650	2650	2650
	W410	12	3 ⁹ / ₁₆	9 ¹ / ₈	2 ¹ / ₂	2 ¹ / ₂	2-10d	2-10d	—	1435	1435	1435
	HW410	11	3 ⁹ / ₁₆	9 ¹ / ₈	2 ¹ / ₂	2 ¹ / ₂	4-10d	2-10d	—	3235	3235	3235
4x12	BA412 (Min)	14	3 ⁹ / ₁₆	11	3	2 ¹ / ₂	16-16d	2-10dx1 ¹ / ₂	225	2665	2665	2665
	BA412 (Max)	14	3 ⁹ / ₁₆	11	3	2 ¹ / ₂	16-16d	8-10dx1 ¹ / ₂	1005	2665	2665	2665
	B412	12	3 ⁹ / ₁₆	11	2 ¹ / ₂	2 ¹ / ₂	14-16d	6-16d	865	2650	2650	2650
	HW412	11	3 ⁹ / ₁₆	11	2 ¹ / ₂	2 ¹ / ₂	4-10d	2-10d	—	3235	3235	3235
4x14	B414	12	3 ⁹ / ₁₆	13	2 ¹ / ₂	2 ¹ / ₂	14-16d	6-16d	865	2650	2650	2650
	WNP414	12	3 ⁹ / ₁₆	13	2 ¹ / ₂	2 ³ / ₁₆	2-10d	2-10d	—	2525	2525	2525
	HW414	11	3 ⁹ / ₁₆	13	2 ¹ / ₂	2 ¹ / ₂	4-10d	2-10d	—	3235	3235	3235
4x16	WNP416	12	3 ⁹ / ₁₆	15	2 ¹ / ₂	2 ³ / ₁₆	2-10d	2-10d	—	2525	2525	2525
	B416	12	3 ⁹ / ₁₆	15	2 ¹ / ₂	2 ¹ / ₂	14-16d	6-16d	865	2650	2650	2650
	HW416	11	3 ⁹ / ₁₆	15	2 ¹ / ₂	2 ¹ / ₂	4-10d	2-10d	—	3235	3235	3235
6x6	WNP66	12	5 ¹ / ₂	5 ³ / ₈	2 ¹ / ₂	2 ⁵ / ₁₆	3-10d	2-10d	—	2525	2525	2525
	HW66	11	5 ¹ / ₂	5 ³ / ₈	2 ¹ / ₂	2 ¹ / ₂	4-10d	2-10d	—	3235	3235	3235
6x8	WNP68	12	5 ¹ / ₂	7 ¹ / ₈	2 ¹ / ₂	2 ⁵ / ₁₆	3-10d	2-10d	—	2525	2525	2525
	HW68	11	5 ¹ / ₂	7 ¹ / ₈	2 ¹ / ₂	2 ¹ / ₂	4-10d	2-10d	—	3235	3235	3235
6x10	WNP610	12	5 ¹ / ₂	9 ¹ / ₈	2 ¹ / ₂	2 ⁵ / ₁₆	3-10d	2-10d	—	2525	2525	2525
	B610	12	5 ¹ / ₂	9 ¹ / ₈	2 ¹ / ₂	2 ¹ / ₂	14-16d	6-16d	865	2650	2650	2650
	HW610	11	5 ¹ / ₂	9 ¹ / ₈	2 ¹ / ₂	2 ¹ / ₂	4-10d	2-10d	—	3235	3235	3235
6x12	HW612	11	5 ¹ / ₂	11	2 ¹ / ₂	2 ¹ / ₂	4-10d	2-10d	—	3235	3235	3235
	B612	12	5 ¹ / ₂	11	2 ¹ / ₂	2 ¹ / ₂	14-16d	6-16d	865	2650	2650	2650
6x14	HW614	11	5 ¹ / ₂	13	2 ¹ / ₂	2 ¹ / ₂	4-10d	2-10d	—	3235	3235	3235
	B614	12	5 ¹ / ₂	13	2 ¹ / ₂	2 ¹ / ₂	14-16d	6-16d	865	2650	2650	2650
6x16	HW616	11	5 ¹ / ₂	15	2 ¹ / ₂	2 ¹ / ₂	4-10d	2-10d	—	3235	3235	3235
	B616	12	5 ¹ / ₂	15	2 ¹ / ₂	2 ¹ / ₂	14-16d	6-16d	865	2650	2650	2650
8x8	HW88	7	7 ¹ / ₂	7 ¹ / ₈	2 ¹ / ₂	2 ¹ / ₂	4-10d	2-10d	—	3235	3235	3235
8x10	HW810	7	7 ¹ / ₂	9 ¹ / ₈	2 ¹ / ₂	2 ¹ / ₂	4-10d	2-10d	—	3235	3235	3235
8x12	HW812	7	7 ¹ / ₂	11	2 ¹ / ₂	2 ¹ / ₂	4-10d	2-10d	—	3235	3235	3235
8x14	HW814	7	7 ¹ / ₂	13	2 ¹ / ₂	2 ¹ / ₂	4-10d	2-10d	—	3235	3235	3235
8x16	HW816	7	7 ¹ / ₂	15	2 ¹ / ₂	2 ¹ / ₂	4-10d	2-10d	—	3235	3235	3235

See footnotes on page 90.

LRUZ Rafter Hanger

Solid Sawn Joist Hangers

The LRUZ offers an economic alternative for those applications requiring a sloped hanger for rafter-to-ridge connections. Used with solid-sawn rafters, the LRUZ's unique design enables the hanger to be installed either before or after the rafter is in place. The field-adjustable seat helps improve job efficiency by eliminating mismatched angles in the field and lead times associated with special orders. The LRUZ offers comparable or better load capacity to other rafter hangers at a reduced cost while using fewer fasteners.

FEATURES:

- The open design and ability to field-adjust the slope makes the LRUZ ideal for both retrofit or new applications
- Accommodates roof pitches from 0:12 to 14:12
- Slopes up or down to 45° (12:12). For slopes greater than 45° up to 49° (14:12), allowable loads are 0.85 of table loads
- For added versatility, the fasteners on the face of the hanger are placed high enabling the bottom of the rafter to hang below the ridge beam (see "Max. C₁" dimension)
- Can be installed using nails or Simpson Strong-Tie® Strong-Drive® SD Connector screws

MATERIAL: 18 gauge

FINISH: ZMAX® coating (G-185)

INSTALLATION:

- Use all specified fasteners. See General Notes.
- Joist fasteners must be installed at an angle through the rafter or joist into the header to achieve the table loads.
- See alternate installation on page 93 for retrofit applications.

CODES: See page 12 for Code Reference Key Chart.

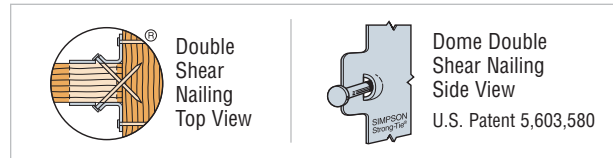
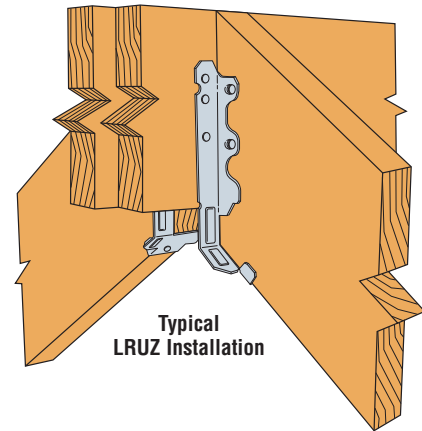
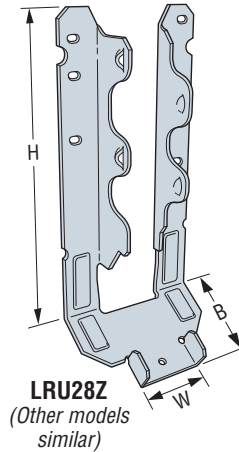

These products are available with additional corrosion protection. Additional products on this page may also be available with this option, check with Simpson Strong-Tie for details.

These products are approved for installation with the Strong-Drive® SD Connector screw. See page 27 for more information.

Standard Installation^{1,2,3}

Model No.	Dimensions (in.)				Fasteners ^{3,4}		DF/SP Allowable Loads ¹				SPF/HF Allowable Loads ¹				Code Ref.
	W	H	B	Max. C ₁	Face	Joist	Uplift ² (160)	Floor (100)	Snow (115)	Roof (125)	Uplift ² (160)	Floor (100)	Snow (115)	Roof (125)	
LRU26Z	1 1/16	5 1/4	1 1/16	1 3/4	4-16d	5-16d	880	1020	1170	1270	760	875	1000	1085	18
					4-10d	5-10d	645	855	980	990	555	730	835	850	
					4-SD #10x2 1/2	5-SD #10x2 1/2	770	1215	1395	1425	660	935	1075	1170	
					4-SD #10x1 1/2	5-SD #10x2 1/2	770	1045	1200	1305	660	830	950	1035	
LRU28Z	1 1/16	6 1/16	1 1/16	2 5/8	6-16d	5-16d	880	1300	1355	1355	760	1110	1165	1165	
					6-10d	5-10d	805	1050	1050	1050	695	900	900	900	
					6-SD #10x2 1/2	5-SD #10x2 1/2	1025	1480	1480	1480	880	1265	1270	1270	
					6-SD #10x1 1/2	5-SD #10x2 1/2	1025	1390	1480	1480	880	1105	1270	1270	
LRU210Z	1 1/16	8 3/16	1 1/16	1 3/4	6-16d	7-16d	1100	1535	1620	1620	945	1310	1395	1395	
					6-10d	7-10d	1100	1285	1430	1430	945	1095	1230	1230	
					6-SD #10x2 1/2	7-SD #10x2 1/2	1510	1805	1805	1805	1300	1405	1550	1550	
					6-SD #10x1 1/2	7-SD #10x2 1/2	1510	1570	1805	1805	1300	1240	1430	1550	
LRU212Z	1 1/16	10 1/16	1 1/16	3 1/2	6-16d	7-16d	1305	1535	1755	1905	1120	1310	1500	1625	
					6-10d	7-10d	1305	1285	1430	1430	1120	1095	1230	1230	
					6-SD #10x2 1/2	7-SD #10x2 1/2	1850	1820	1915	1915	1590	1405	1615	1645	
					6-SD #10x1 1/2	7-SD #10x2 1/2	1850	1570	1805	1915	1590	1240	1430	1555	

1. Allowable loads are based on a minimum 3" carrying member. For single 2x carrying members, use 10dx1 1/2" nails into the face and 10d commons into the joist, and reduce the allowable load to 0.81 of the tabulated value for 10d nails. Alternatively, use #10x1 1/2" Strong-Drive® SD Connector screws into the face and #10x2 1/2" Strong-Drive SD Connector screws into the joist as shown in the table.
 2. Uplift loads have been increased for wind or earthquake loading with no further increase allowed. Reduce where other loads govern.
 3. **NAILS:** 16d = 0.162" dia. x 3 1/2" long, 10d = 0.148" dia. x 3" long, 10dx1 1/2 = 0.148" dia. x 1 1/2" long. See pages 22-23 for other nail sizes and information.
 4. **SCREWS:** SD #10x2 1/2 (model SD10212) = 0.161" dia. x 2 1/2" long, SD #10x1 1/2 (model SD10112) = 0.161" dia. x 1 1/2" long.

LRUZ Rafter Hanger

Alternate Installation for Retrofit Applications

When an existing roof deck prevents the horizontal installation of fasteners, #10x2½" Strong-Drive® SD Connector screws may be installed sloped upward to match the roof pitch (49° max.). Use table values for an installation with 10d nails when Strong-Drive SD Connector screws are sloped. Nails may not be installed sloped upward.

Alternate Installation for Retrofit

Model No.	Angled Fasteners ^{3,4}		DF/SP Allowable Loads ¹				SPF/HF Allowable Loads ¹				Code Ref.
	Face	Joist	Uplift ² (160)	Floor (100)	Snow (115)	Roof (125)	Uplift ² (160)	Floor (100)	Snow (115)	Roof (125)	
LRU26Z	4-SD #10x2½	5-SD #10x2½	645	855	980	990	555	730	835	850	18
LRU28Z	6-SD #10x2½	5-SD #10x2½	805	1050	1050	1050	695	900	900	900	
LRU210Z	6-SD #10x2½	7-SD #10x2½	1100	1285	1430	1430	945	1095	1230	1230	
LRU212Z	6-SD #10x2½	7-SD #10x2½	1305	1285	1430	1430	1120	1095	1230	1230	

1. Allowable loads are based on a minimum 3" thick carrying member.
2. Uplift loads have been increased for wind or earthquake loading with no further increase allowed. Reduce where other loads govern.
3. Fasteners may be angled upward a maximum of 49°.
4. **SCREWS:** SD #10x2½ (model SD10212) = 0.161" dia. x 2½" long.

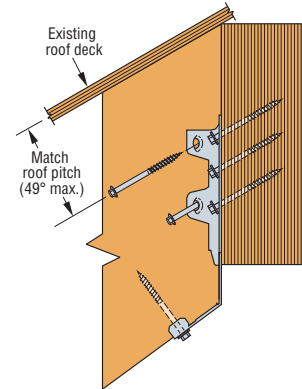

Alternate Installation for Retrofit Applications

Minimum Ridge Beam Depth (in inches)

Rafter Pitch	LRU26Z		LRU28Z			LRU210Z			LRU212Z	
	Rafter Size		Rafter Size			Rafter Size			Rafter Size	
	2x6	2x8	2x6	2x8	2x10	2x8	2x10	2x12	2x10	2x12
2:12	3¾	5¾	—	5½	7¼	—	7¾	9¾	—	9¼
3:12	3¾	5¾	—	5½	7¼	—	7¾	9¾	—	9¼
4:12	4	5¾	—	5½	7¼	—	8	10¾	—	9¼
5:12	4¼	6¾	—	5½	7¾	—	8¼	10½	—	9¼
6:12	4¾	6¾	—	5½	7¾	—	8¾	10¾	—	9¼
7:12	4¾	6¾	—	5¾	8¾	6¾	9	11¼	—	9½
8:12	4¾	7	—	6¾	8½	7	9¾	11¾	7¾	10
9:12	5¾	7¾	—	6½	9	7¾	9¾	12¾	8¾	10¾
10:12	5¾	7¾	4½	6¾	9¾	7¾	10¼	12¾	8½	11¾
11:12	5¾	8¾	4¾	7¼	9¾	8¾	10¾	13½	9	11¾
12:12	6	8½	5¾	7¾	10½	8½	11¾	14¾	9¾	12¾
13:12	6¾	9	5½	8¾	11¾	9	12	14¾	10¼	13¾
14:12	6¾	9½	5¾	8¾	11¾	9½	12½	15¾	10¾	13¾

1. Minimum ridge beam depths shown assume rafter and ridge beam are flush at the top.
2. Minimum ridge beam depths have been determined to ensure the Max C₁ dimension for the LRU is not exceeded. Deeper ridge beams may be required to support the rafter loads as determined by the Designer.
3. The International Residential Code requires the ridge to be not less in depth than the cut end of the rafter unless the ridge is designed as a beam.

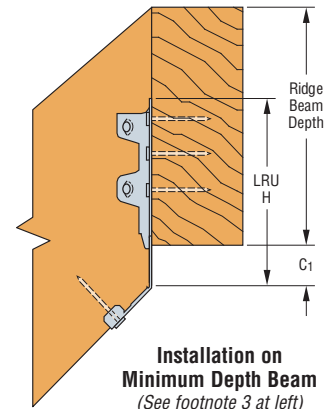

Installation on Minimum Depth Beam
(See footnote 3 at left)

PF/PFB/PFDB Post Frame Hangers

The PF series hangers have been redesigned to accommodate collated nails (0.148x1½) as well as the 10d common nail (0.148x3). The PFB and PFDB have dome-shaped joist nail holes that guide nails into the proper installation angle. The redesign also features a folded seat that raises the 2x joist very slightly above the seat radius to enable a tighter connection to the back of the hanger.

FEATURES:

- Installation prongs make setting the hanger quick and easy
- Sizes are available for 2x8 joists

MATERIAL: 20 gauge

FINISH: Galvanized. Some products available in ZMAX® coating; see Corrosion Information, pages 13-15.

INSTALLATION: • Use all specified fasteners. See General Notes.

- 10d common purlin nails must be driven at an angle through the purlin into the header. Combine with top nails to achieve table loads.
- 10dx1½ purlin nails must be driven at an angle into the purlin but do not penetrate into the header. Combine with back face fasteners and top nails to achieve table loads.

CODES: See page 12 for Code Reference Key Chart.

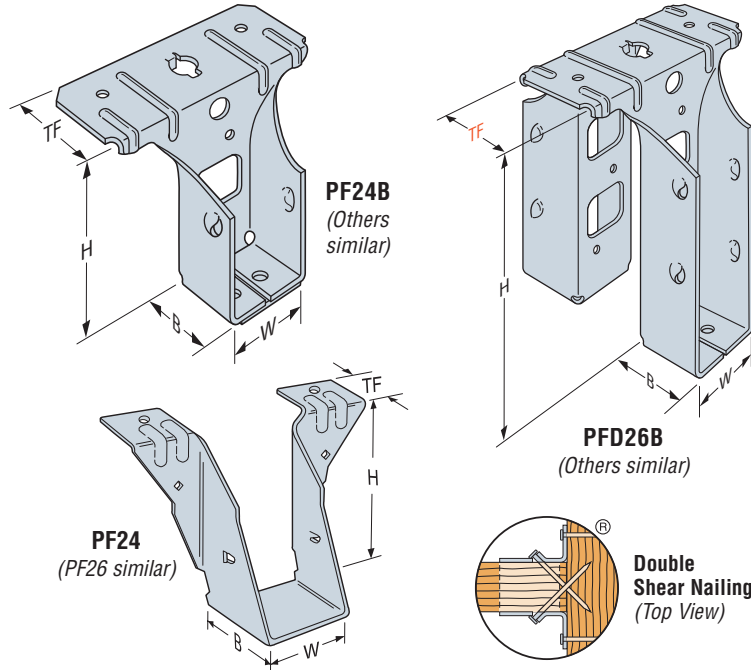

Solid Sawn Joist Hangers

These products are available with additional corrosion protection. Additional products on this page may also be available with this option, check with Simpson Strong-Tie for details.

These products are approved for installation with the Strong-Drive® SD Connector screw. See page 27 for more information.

Model No.	Dimensions (in.)				Fasteners			DF/SP Allowable Loads					SPF/HF Allowable Loads					Code Ref.
	W	H	B	TF	Top	Face	Joist	Uplift1 (160)	Floor (100)	Snow (115)	Roof (125)	Wind (160)	Uplift1 (160)	Floor (100)	Snow (115)	Roof (125)	Wind (160)	
PF24	1⅞	3⅞	1½	1⅞	2-10d	2-10d	2-10d	310	955	955	955	955	230	650	660	660	660	110, F9, L11
PF24B	1⅞	3⅞	1¼	1½	2-10dx1½	2-10dx1½	2-10dx1½	345	965	965	965	965	295	785	785	785	785	160
					2-10d	—	2-10d	375	1005	1005	1005	1005	290	680	680	680	680	
PFD24B	1⅞	3⅞	1¼	1⅞	2-10dx1½	2-10dx1½	2-10dx1½	290	985	985	985	985	230	830	830	830	830	160
					2-10d	—	2-10d	300	1090	1090	1090	1090	210	830	860	880	945	
PFDS24B	1⅞	3⅞	1¼	3⅞	4-10dx1½	2-10dx1½	2-10dx1½	290	985	985	985	985	230	830	830	830	830	160
					4-10d	—	2-10d	300	1090	1090	1090	1090	210	830	860	880	945	
PF26	1⅞	5⅞	1½	1⅞	2-10d	2-10d	2-10d	310	955	955	955	955	455	805	850	880	905	110, F9, L11
PF26B	1⅞	5⅞	1¼	1½	2-10dx1½	3-10dx1½	4-10dx1½	545	1235	1235	1235	1235	470	1005	1005	1005	1005	160
					2-10d	—	4-10d	625	1200	1200	1200	1200	480	810	810	810	810	
PFD26B	1⅞	5⅞	1¼	1⅞	2-10dx1½	3-10dx1½	4-10dx1½	525	1235	1235	1235	1235	420	1030	1040	1040	1040	160
					2-10d	—	4-10d	650	1290	1290	1290	1290	465	1030	1090	1125	1255	
PFDS26B	1⅞	5⅞	1¼	3⅞	4-10dx1½	3-10dx1½	4-10dx1½	525	1235	1235	1235	1235	420	1030	1040	1040	1040	160
					4-10d	—	4-10d	650	1290	1290	1290	1290	465	1030	1090	1125	1255	
PFDL26B	1⅞	5¼	1¼	1⅞	2-10dx1½	3-10dx1½	4-10dx1½	525	1235	1235	1235	1235	420	1030	1040	1040	1040	160
					2-10d	—	4-10d	670	1345	1350	1350	1350	465	1030	1090	1125	1255	
PF28B	1⅞	7⅞	1¼	1½	2-10dx1½	4-10dx1½	6-10dx1½	675	1335	1335	1335	1335	580	1085	1085	1085	1085	160
					2-10d	—	6-10d	850	1580	1650	1650	1650	655	1115	1115	1115	1115	
PFD28B	1⅞	7⅞	1¼	1⅞	2-10dx1½	4-10dx1½	6-10dx1½	810	1370	1370	1370	1370	680	1160	1160	1160	1160	160
					2-10d	—	6-10d	1050	1580	1680	1745	1975	730	1230	1315	1370	1570	
PFDS28B	1⅞	7⅞	1¼	3⅞	4-10dx1½	4-10dx1½	6-10dx1½	895	1370	1370	1370	1370	730	1160	1160	1160	1160	160
					4-10d	—	6-10d	1050	1580	1680	1745	1975	730	1230	1315	1370	1570	
PFDL28B	1⅞	7	1¼	1⅞	2-10dx1½	4-10dx1½	6-10dx1½	810	1370	1370	1370	1370	680	1160	1160	1160	1160	160
					2-10d	—	6-10d	1050	1580	1680	1745	1970	730	1230	1315	1370	1570	

1. Uplift loads have been increased for wind or earthquake loading with no further increase allowed; reduce where other loads govern.
 2. **NAILS:** 10d = 0.148" dia. x 3" long, 10dx1½ = 0.148" dia. x 1½" long. See pages 22-23 for other nail sizes and information.

C-C-2015 © 2015 SIMPSON STRONG-TIE COMPANY INC. PRINTED 12/14 (This page has been updated since printing)

LSU/LSSU Adjustable Light Slopeable/Skewable U Hangers



This product is preferable to similar connectors because of a) easier installation, b) higher loads, c) lower installed cost, or a combination of these features.

The LSU and LSSU series of hangers may be sloped and skewed in the field, offering a versatile solution for attaching joists and rafters. These hangers may be sloped up or down and skewed left or right, up to 45°.

MATERIAL: See table

FINISH: Galvanized. Some products available in ZMAX® coating; see Corrosion Information, pages 13-15.

INSTALLATION:

- Use all specified fasteners. See General Notes.
- Attach the sloped joist at both ends so that the horizontal force developed by the slope is fully supported by the supporting members.
- To see an installation video on this product, visit www.strongtie.com.

CODES: See page 12 for Code Reference Key Chart.

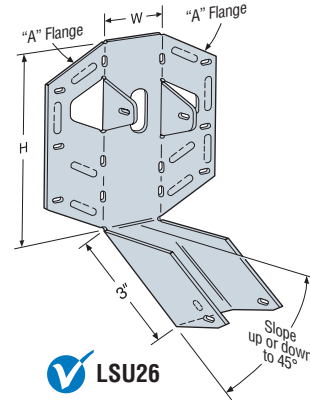

LSU26

LSU and LSSU INSTALLATION SEQUENCE

(For Skewed or Sloped/Skewed Applications)

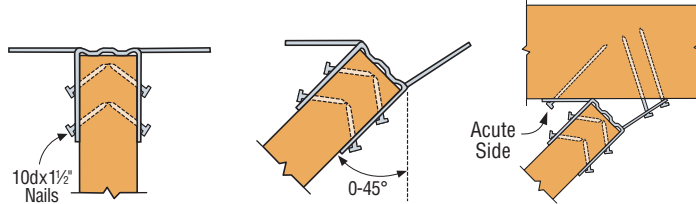

STEP 1

Nail hanger to slope-cut carried member, installing seat nail first. No bevel necessary for skewed installation. Install joist nails at 45° angle.

STEP 2

Skew flange from 0-45°. Bend other flange back along centerline of slots until it meets the header. Bend one time only.

STEP 3

Attach hanger to the carrying member, acute angle side first (see footnote 4). Install nails at an angle.

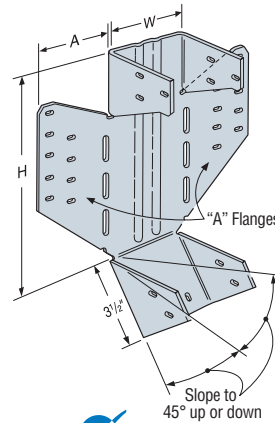

LSSU410
(LSSU210-2 similar)

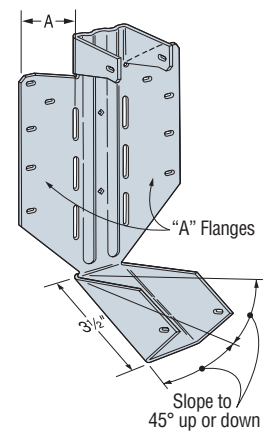

LSSU28

These products are available with additional corrosion protection. Additional products on this page may also be available with this option, check with Simpson Strong-Tie for details.

Joist Width	Model No.	Ga	Dimensions			Fasteners		DF/SP Allowable Loads				SPF/HF Allowable Loads				Code Ref.
			W	H	A	Face	Joist	Uplift ² (160)	Floor (100)	Snow (115)	Roof (125)	Uplift ² (160)	Floor (100)	Snow (115)	Roof (125)	
Sloped Only Hangers																
1½	LSU26	18	1½	4¾	1½	6-10d	5-10dx1½	535	695	810	865	415	600	695	745	I8, F7, L15
1½	LSSU28	18	1½	7½	1½	10-10d	5-10dx1½	535	1110	1275	1390	415	960	1105	1200	
1½	LSSU210	18	1½	8½	1¾	10-10d	7-10dx1½	875	1110	1275	1390	625	960	1105	1200	I8, F7, L15
2½	LSSUH310	16	2½	8½	3¾	18-16d	12-10dx1½	1150	2295	2295	2295	990	1930	1930	1930	
3	LSSU210-2	16	3¾	8½	2¾	18-16d	12-10dx1½	1150	2430	2795	3035	990	2160	2485	2700	I8, F7, L15
3½	LSSU410	16	3¾	8½	2¾	18-16d	12-10dx1½	1150	2430	2795	3035	990	2160	2485	2700	
Skewed Hangers or Sloped and Skewed																
1½	LSU26	18	1½	4¾	1½	6-10d	5-10dx1½	535	695	810	865	415	600	695	745	I8, F7, L15
1½	LSSU28	18	1½	7½	1½	9-10d	5-10dx1½	450	885	885	885	415	765	765	765	
1½	LSSU210	18	1½	8½	1¾	9-10d	7-10dx1½	785	995	1145	1205	625	860	995	1050	I8, F7, L15
2½	LSSUH310	16	2½	8½	3¾	14-16d	12-10dx1½	1150	1600	1600	1600	990	1385	1385	1385	
3	LSSU210-2	16	3¾	8½	2¾	14-16d	12-10dx1½	1150	1625	1625	1625	990	1365	1365	1365	I8, F7, L15
3½	LSSU410	16	3¾	8½	2¾	14-16d	12-10dx1½	1150	1625	1625	1625	990	1365	1365	1365	

1. Roof loads are 125% of floor loads unless limited by other criteria.
2. Uplift loads include an increase for wind or earthquake loading with no further increase allowed; reduce when other loads govern.
3. Truss chord cross-grain tension may limit allowable loads in accordance with ANSI/TPI 1-2007. Simpson Strong-Tie® Connector Selector™ Software includes the evaluation of cross-grain tension in its hanger allowable loads. For additional information, contact Simpson Strong-Tie.
4. For skewed LSSU hangers, the inner most face fasteners on the acute angle side are not installed.
5. Do not substitute 10dx1½ nails for face nails on slope and skew combinations or skewed only LSU and LSSU.
6. **NAILS:** 16d = 0.162" dia. x 3½" long, 10d = 0.148" dia. x 3" long, 10dx1½ = 0.148" dia. x 1½" long. See pages 22-23 for other nail sizes and information.

SUR/SUL/HSUR/HSUL Skewed 45° Hangers



This product is preferable to similar connectors because of a) easier installation, b) higher loads, c) lower installed cost, or a combination of these features.

The SU and HSU series of hangers are skewed 45° left or right. Angled nail slots direct nails for proper installation.

MATERIAL: SUR and SUL—16 gauge; HSUR and HSUL—14 gauge

FINISH: Galvanized. Some products available in ZMAX® coating; see Corrosion Information, pages 13-15.

INSTALLATION: • Use all specified fasteners. See General Notes.

- These hangers will normally accommodate a 40° to 50° skew.
- Illustration shows left and right skews SUR/L (SUR=skewed right; SUL=skewed left).
- The joist end may be square cut or bevel cut.
- For installations to concrete/masonry walls, see page 175.

OPTIONS:

- Available with the A2 flange turned in on the 2-2x and 4x models only (see illustration).
- To order, add "C" (for concealed) to the product name.
- For example, specify HSURC46, HSULC46, SURC46, or SULC46.

CODES: See page 12 for Code Reference Key Chart.

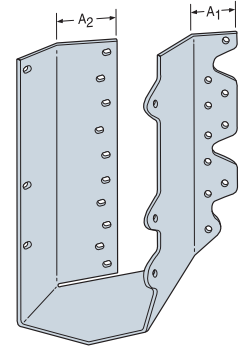
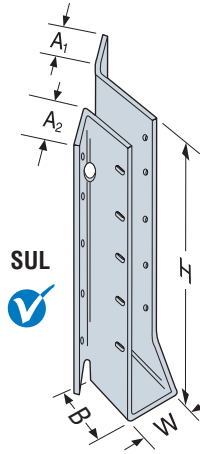

HSULC
Available for 2-2x and 4x models only

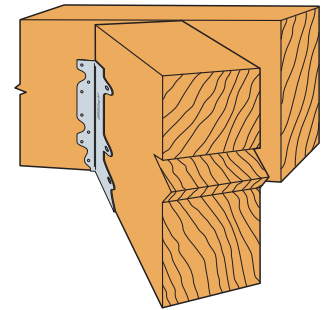
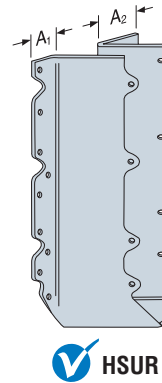

Typical SUR410 Installation

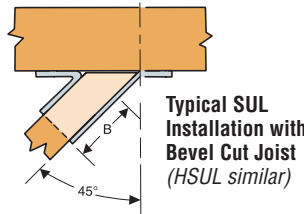
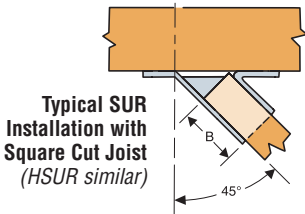

These products are available with additional corrosion protection. Additional products on this page may also be available with this option, check with Simpson Strong-Tie for details.

These products are approved for installation with the Strong-Drive® SD Connector screw. See page 27 for more information.

Joist Size	Model No.	Dimensions (in)					Fasteners		DF/SP Species Header Allowable Loads				SPF/HF Species Header Allowable Loads				Code Ref.
		W	H	B	A ₁	A ₂	Face	Joist	Uplift (160)	Floor (100)	Roof		Uplift (160)	Floor (100)	Roof		
											Snow (115)	Const (125)			Snow (115)	Const (125)	
2x4	SUR/L24	1 ¹ / ₁₆	3 ¹ / ₂	2	1 ¹ / ₈	1 ¹ / ₄	4-16d	4-10dx1 ¹ / ₂	450	575	655	705	385	495	560	605	17, F6, L17
2x6, 8	SUR/L26	1 ¹ / ₁₆	5	2	1 ¹ / ₈	1 ¹ / ₁₆	6-16d	6-10dx1 ¹ / ₂	765	865	980	1055	660	745	845	910	
2x10, 12	SUR/L210	1 ¹ / ₁₆	8 ¹ / ₈	2	1 ¹ / ₈	1 ¹ / ₁₆	10-16d	10-10dx1 ¹ / ₂	1250	1440	1635	1760	1075	1240	1405	1515	
2x14	SUR/L214	1 ¹ / ₁₆	10	2	1 ¹ / ₈	1 ¹ / ₁₆	12-16d	12-10dx1 ¹ / ₂	2165	1730	1960	2115	1860	1485	1685	1820	
3x10, 12	SUR/L2.56/9	2 ¹ / ₁₆	8 ¹³ / ₁₆	3 ³ / ₁₆	1 ¹ / ₈	2 ¹ / ₈	14-16d	2-10dx1 ¹ / ₂	225	2015	2285	2465	195	1735	1965	2120	19, L17
3x14	SUR/L2.56/11	2 ¹ / ₁₆	11 ¹ / ₁₆	3 ³ / ₁₆	1 ¹ / ₈	2 ¹ / ₈	16-16d	2-10dx1 ¹ / ₂	225	2305	2615	2665	195	1980	2245	2290	
(2) 2x6, 8	SUR/L26-2	3 ¹ / ₈	4 ¹⁵ / ₁₆	2 ⁵ / ₈	1 ¹ / ₁₆	2 ³ / ₈	8-16d	4-16dx2 ¹ / ₂	815	1150	1305	1400	700	990	1005	1005	17, F6, L17
(2) 2x6, 8	HSUR/L26-2	3 ¹ / ₈	4 ¹⁵ / ₁₆	2 ⁷ / ₁₆	1 ¹ / ₄	2 ³ / ₁₆	12-16d	4-16dx2 ¹ / ₂	815	1785	2000	2000	700	1540	1720	1720	
(2) 2x10, 12	SUR/L210-2	3 ¹ / ₈	8 ¹¹ / ₁₆	2 ⁵ / ₈	1 ¹ / ₁₆	2 ³ / ₈	14-16d	6-16dx2 ¹ / ₂	1300	2015	2285	2465	1120	1735	1780	1780	
(2) 2x10, 12	HSUR/L210-2	3 ¹ / ₈	8 ¹¹ / ₁₆	2 ⁷ / ₁₆	1 ¹ / ₄	2 ³ / ₁₆	20-16d	6-16dx2 ¹ / ₂	1300	2975	3360	3610	1120	2565	2895	3110	
(2) 2x14	HSUR/L214-2	3 ¹ / ₈	12 ¹ / ₁₆	2 ⁷ / ₁₆	1 ¹ / ₄	2 ³ / ₁₆	26-16d	8-16dx2 ¹ / ₂	1795	3870	4365	4695	1550	3330	3760	4045	
4x6, 8	SUR/L46	3 ¹ / ₁₆	4 ³ / ₄	2 ⁵ / ₈	1	2 ³ / ₈	8-16d	4-16d	815	1150	1305	1400	700	990	1005	1005	L17
4x6, 8	HSUR/L46	3 ¹ / ₁₆	4 ³ / ₄	2 ⁷ / ₁₆	1	2 ³ / ₁₆	12-16d	4-16d	815	1785	2000	2000	700	1540	1720	1720	17, F6, L12, L17
4x10, 12	SUR/L410	3 ¹ / ₁₆	8 ¹ / ₂	2 ⁵ / ₈	1	2 ³ / ₈	14-16d	6-16d	1300	2015	2285	2465	1120	1735	1780	1780	19, F8, L12
4x10, 12	HSUR/L410	3 ¹ / ₁₆	8 ¹ / ₂	2 ⁷ / ₁₆	1	2 ³ / ₁₆	20-16d	6-16d	1300	2975	3360	3610	1120	2565	2895	3110	17, F6, L17
4x14	SUR/L414	3 ¹ / ₁₆	12 ¹ / ₂	2 ⁵ / ₈	1	2 ³ / ₈	18-16d	8-16d	1765	2500	2500	2500	1520	1795	1795	1795	
4x14	HSUR/L414	3 ¹ / ₁₆	12 ¹ / ₂	2 ⁷ / ₁₆	1	2 ³ / ₁₆	26-16d	8-16d	1795	3870	4365	4695	1550	3330	3760	4045	17, F6, L12, L17

1. Uplift loads have been increased for wind or earthquake loading with no further increase allowed; reduce where other loads govern.
 2. Roof loads are 125% of floor loads unless limited by other criteria.
 3. Truss chord cross-grain tension may limit allowable loads in accordance with ANSI/TPI 1-2007.
 Simpson Strong-Tie® Connector Selector™ Software includes the evaluation of cross-grain tension in its hanger allowable loads. For additional information, contact Simpson Strong-Tie.
 4. **NAILS:** 16d = 0.162" dia. x 3¹/₂" long, 16dx2¹/₂ = 0.162" dia. x 2¹/₂" long, 10dx1¹/₂ = 0.148" dia. x 1¹/₂" long.
 See pages 22-23 for other nail sizes and information.

VPA Variable Pitch Connectors

The VPA may be sloped in the field, offering a versatile solution for attaching rafters to the top plate. It will adjust to accommodate slopes between 3:12 and 12:12, making it a complement to the versatile LSSU. This connector eliminates the need for notched rafters, beveled top plates and toe nailing.

MATERIAL: 18 gauge

FINISH: Galvanized

INSTALLATION:

- Use all specified fasteners. See General Notes.

CODES: See page 12 for Code Reference Key Chart.

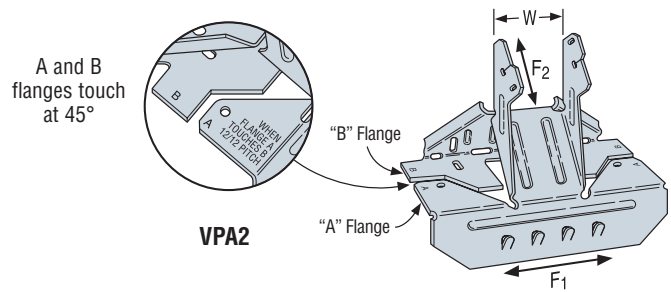

Joist Width	Model No.	W	Fasteners		DF/SP Allowable Loads				SPF/HF Allowable Loads				Code Ref.
			Carrying Member	Carried Member	Uplift (160)	Download	Lateral (160)		Uplift (160)	Download	Lateral (160)		
							F ₁	F ₂			F ₁	F ₂	
1½	VPA2	1⅞	8-10d	2-10dx1½	295	1050	375	250	250	870	325	250	18, F7, L15
2½	VPA3	2⅞	9-10d	2-10dx1½	295	1230	375	250	250	1020	325	250	
3½	VPA4	3⅞	11-10d	2-10dx1½	295	1230	375	250	250	1020	325	250	

1. Uplift loads include an increase for wind or earthquake loading with no further increase allowed; reduce where other loads govern.
2. Loads may not be increased for short-term loading.

3. **NAILS:** 10d = 0.148" dia. x 3" long, 10dx1½ = 0.148" dia. x 1½" long. See pages 22-23 for other nail sizes and information.

VPA INSTALLATION SEQUENCE

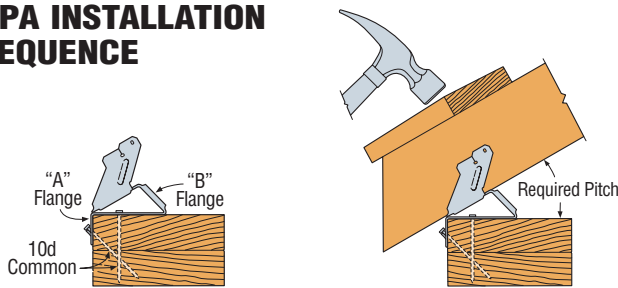

STEP 1
Install top nails and face PAN nails in "A" flange to outside wall top plate.

STEP 2
Seat rafter with a hammer, adjusting "B" flange to the required pitch.

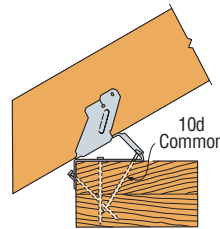

STEP 3
Install "B" flange nails in the obround nail holes, locking the pitch.

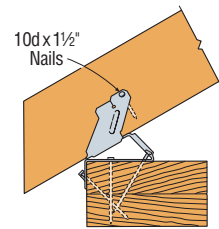

STEP 4
Install 10dx1½ nail into tab nail hole. Hammer nail in at a slight angle to prevent splitting.

HCP Hip Corner Plates

The HCP connects a rafter or joist to double top plates at a 45° angle.

MATERIAL: 18 gauge

FINISH: HCP2—galvanized or ZMAX® coating; HCP4Z—ZMAX coating

INSTALLATION: • Use all specified fasteners. See General Notes.

- Attach HCP to double top plates; birdsmouth not required for table uplift loads but may be required for download.
- Install rafter and complete nailing. Rafter may be sloped to 45°.

CODES: See page 12 for Code Reference Key Chart.

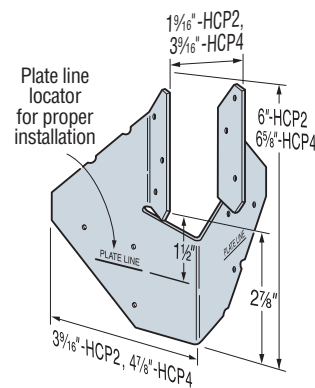

HCP2
(HCP4Z similar)
U.S. Patent 5,380,115

These products are available with additional corrosion protection. Additional products on this page may also be available with this option, check with Simpson Strong-Tie for details.

Member Size	Model No.	Fasteners		DF/SP Allowable Loads		SPF/HF Allowable Loads		Code Ref.
		To Rafters	To Plates	(160)		(160)		
				Uplift	F ₁	Uplift	F ₁	
2x	HCP2	6-10dx1½	6-10dx1½	645	300	555	260	18, F7, L15
4x	HCP4Z	8-10d	8-10d	1000	265	860	230	

1. Loads include an increase for wind or earthquake loading with no further increase allowed; reduce where other loads govern.
2. The HCP can be installed on the inside and the outside of the wall with a flat bottom chord truss and achieve twice the load capacity.
3. **NAILS:** 10d = 0.148" dia. x 3" long, 10dx1½ = 0.148" dia. x 1½" long. See pages 22-23 for other nail sizes and information.

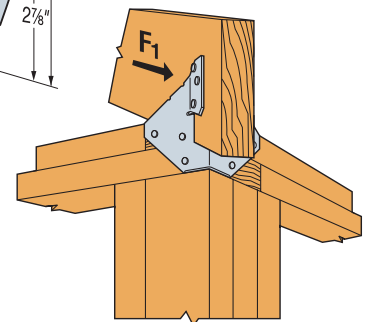

Typical HCP Installation

HRC/HHRC Hip Ridge Connectors

The HRC series are field slopeable connectors that attach hip roof beams to the end of a ridge beam. The HRC may be sloped downward a maximum of 45°.

MATERIAL: HRC22, HRC42—16 gauge;
HRC44—14 gauge; HHRC—12 gauge

FINISH: Galvanized

INSTALLATION:

- Use all specified fasteners. See General Notes.
- On end of ridge—use optional diamond holes on HRC22 and HRC42 to secure the HRC. Bend face flanges on HRC22 back flush with ridge, and complete nailing.
- HRC22 on face of ridge—adjust to correct height and install nails.
- Double bevel-cut hip members to achieve full bearing capacity with HRC.

CODES: See page 12 for Code Reference Key Chart.

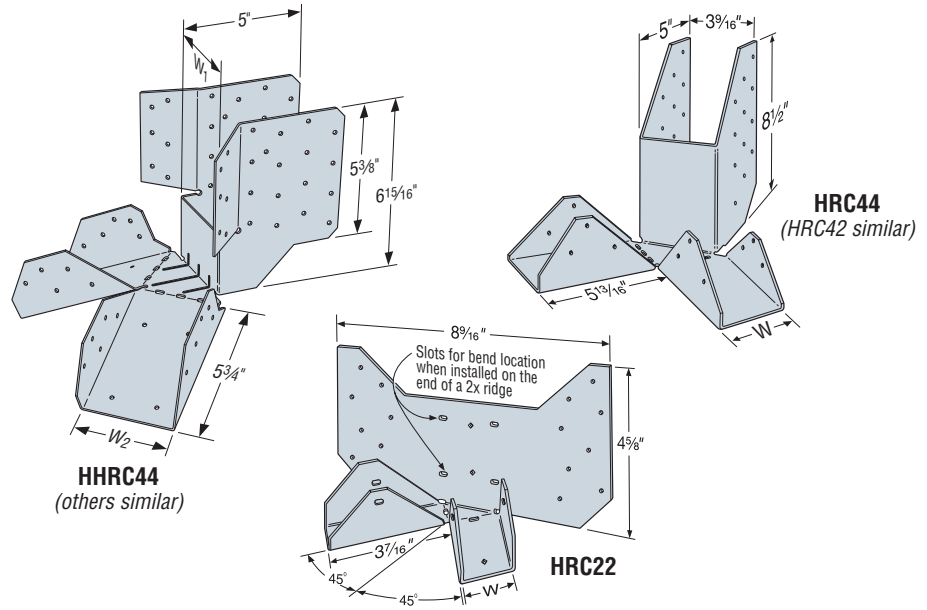

Solid Sawn Joist Hangers

HRC Allowable Loads

Model No.	Member Size		Fasteners		DF/SP Allowable Loads				SPF/HF Allowable Loads				Code Ref.
	W	Ridge	Carrying Member	Each Hip	Uplift (160)	Floor (100)	Snow (115)	Roof (125)	Uplift (160)	Floor (100)	Snow (115)	Roof (125)	
HRC22	1 5/16"	2x or 1 3/4" wide	16-10dx1 1/2"	2-10dx1 1/2"	290	720	830	900	250	625	720	780	18, F7, L15
HRC42	1 5/16"	4x	16-16d	2-10dx1 1/2"	290	1050	1050	1050	250	905	905	905	
HRC44	3 5/16"	4x	24-16d	6-16d	480	1610	1775	1775	410	1385	1525	1525	

1. Allowable loads shown are for each hip. Total load carried by the connector is double this number.
2. Uplift loads include an increase for wind or earthquake loading with no further increase allowed; reduce where other loads govern.
3. Roof loads are 125% of floor loads unless limited by other criteria.
4. **NAILS:** 16d = 0.162" dia. x 3 1/2" long, 10dx1 1/2" = 0.148" dia. x 1 1/2" long. See pages 22-23 for other nail sizes and information.

HHRC Allowable Loads

Model No.	Member Type	Connection Members		Connector Width (in.)		Fasteners ³		Allowable Loads Per Hip				Code Ref.
		Ridge	Hip	Ridge (W ₁)	Hip (W ₂)	Ridge	Each Hip	DF/SP		SPF		
								Download 100/115/125	Uplift (160)	Download 100/115/125	Uplift (160)	
HHRC44	Sawn Lumber	4x	4x	3 3/8"	3 3/8"	(40) SD10212	(22) SD10212	2800	1970	2410	1695	18, L15
	SCL	3 1/2"	3 1/2"	3 3/8"	3 3/8"	(40) SD10212	(22) SD10212	2800	1970	2410	1695	
HHRC5.37/3.56	SCL/Sawn Lumber	5 1/4"	3 1/2"	5 3/8"	3 3/8"	(40) SD10212	(22) SD10212	2800	1970	2410	1695	
HHRC64	Sawn Lumber	5 1/2"	3 1/2"	5 3/8"	3 3/8"	(40) SD10212	(22) SD10212	2800	1970	2410	1695	

1. Allowable loads shown are for each hip. Total load carried at the ridge is 2x the load listed.
2. Uplift loads include an increase for wind or earthquake loading with no further increase allowed; reduce where other loads govern.
3. **FASTENERS:** SD10212 = 0.162" dia. X 2 1/2" long Strong-Drive® SD Connector screws (provided).

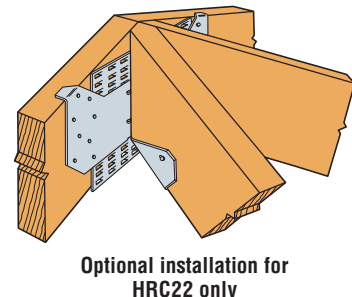
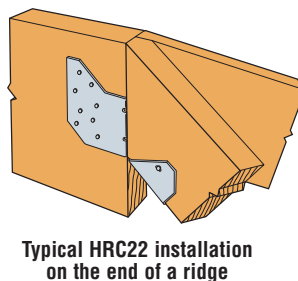
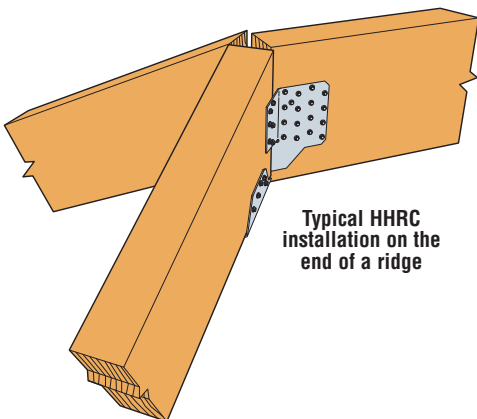

THA/THAC/THAR/L Adjustable Truss Hangers



This product is preferable to similar connectors because of a) easier installation, b) higher loads, c) lower installed cost, or a combination of these features.

The THA series' extra long straps allow full code nailing and can be field-formed to give top flange hanger convenience.

Designed for 4x2 floor trusses and 4x beams, the THAR/L422 has a standard skew of 45°. Straps must be bent for top flange hanger installation. PAN nailing helps eliminate splitting of 4x2 truss bottom chords.

MATERIAL: See table **FINISH:** Galvanized. Some products available in ZMAX® coating; see Corrosion Information, pages 13-15.

INSTALLATION: • Use all specified fasteners. See General Notes.

The following installation methods may be used:

• **Top Flange Installation**—The straps must be field formed over the header – see table for minimum top flange requirements. Install top and face nails according to the table. Top nails shall not be within 1/4" from the edge of the top flange members.

For the THA29, nails used for joist attachment must be driven at an angle so that they penetrate through the corner of the joist and into the header. For all other top flange installations, straighten the double shear nailing tabs and install the nails straight into the joist.

• **Face Mount Installation**—Install all face nails according to the table. Not all nail holes will be filled on all models. On models where there are more nail holes than required, the lowest 4 face holes must be filled. Nails used for the joist attachment must be driven at an angle so that they penetrate through the corner of the joist into the header.

• **Alternate Installation**—The THA 4x hangers may be installed in a top flange configuration using the tabulated fasteners for face mount installation and achieve the face mount installation loads. Install the tabulated face nails into the face and top of the carrying member. Nails used for the joist attachment must be driven at an angle so that they penetrate through the corner of the joist into the header.

• **Uplift**—Lowest face nails must be filled to achieve uplift loads.

OPTIONS: • THA hangers available with the header flanges turned in for 3% (except THA413) and larger, with no load reduction – order THAC hanger.

CODES: See page 12 for Code Reference Key Chart.

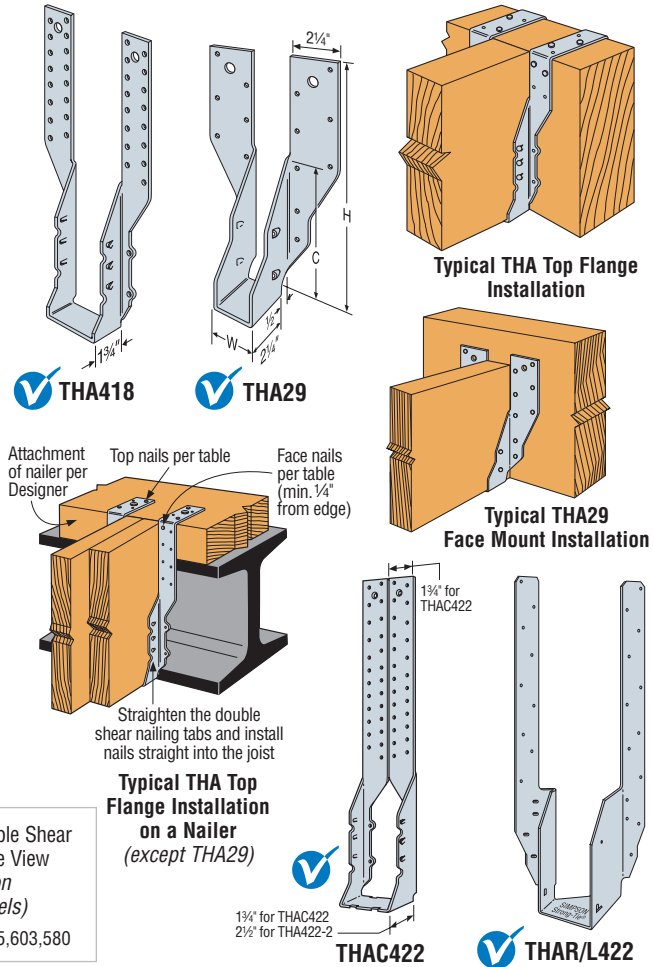

Solid Sawn Joist Hangers

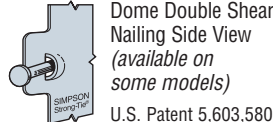
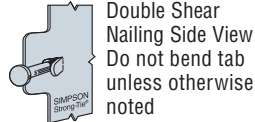

These products are available with additional corrosion protection. Additional products on this page may also be available with this option, check with Simpson Strong-Tie for details.

Minimum Carried Member	Model No.	Ga	Dimensions				Min. 7 Top Flange	Min. Header Depth	Fasteners ¹				DF/SP Allowable Loads				SPF/HF Allowable Loads				Code Ref.
			W	H	C	Carrying Member Top			Carried Member Face	Straight	Slant	Uplift ² (160)	Floor (100)	Snow (115)	Roof (125)	Uplift ² (160)	Floor (100)	Snow (115)	Roof (125)		
																				Carrying Member Top	
TOP FLANGE INSTALLATION																					
2x4	THA29	18	1 3/8	9 1/16	5 1/8	2 7/16	—	4-10d	4-10d	—	4-10d	560	2260	2310	2350	480	1740	1785	1815	18, F7, L15	
2x6	THA213	18	1 3/8	13 3/16	5 1/2	1 1/2	—	4-10d	2-10d	4-10dx1 1/2	—	—	1615	1615	1615	—	1280	1280	1280		
2x6	THA218	18	1 3/8	17 3/16	5 1/2	2	—	4-10d	2-10d	4-10dx1 1/2	—	—	1615	1615	1615	—	1280	1280	1280		
(2) 2x10	THA218-2	16	3 3/8	17 1/16	8	2	—	4-16d	2-16d	6-10d	—	—	2245	2245	2245	—	1935	1935	1935		
(2) 2x10	THA222-2	16	3 3/8	22 3/16	8	2	—	4-16d	2-16d	6-10d	—	—	2245	2245	2245	—	1935	1935	1935		
4x6	THA413	18	3 3/8	13 3/16	4 1/2	1 1/2	—	4-10d	2-10d	4-10d	—	—	1615	1615	1615	—	1280	1280	1280		
4x10	THA418	16	3 3/8	17 1/2	7 7/8	2	—	4-16d	2-16d	6-10d	—	—	2245	2245	2245	—	1935	1935	1935		
4x10	THA422	16	3 3/8	22	7 7/8	2	—	4-16d	2-16d	6-10d	—	—	2245	2245	2245	—	1935	1935	1935		
4x10	THA426	14	3 3/8	26	7 7/8	2	—	4-16d	4-16d	6-16d	—	—	2435	2435	2435	—	2095	2095	2095		F23
4x10	THAR/L422	16	3 3/8	22 3/8	8	2 1/2	—	4-10d	2-10d	1-10d	2-10dx1 1/2	—	1090 ⁴	1090 ⁴	1090 ⁴	—	915 ⁴	915 ⁴	915 ⁴		18, F7, L15
4x10	THAR/L422	16	3 3/8	22 3/8	8	2 1/2	—	4-10d	8-10d	1-10d	2-10dx1 1/2	310	1675	1675	1675	260	1405	1405	1405		
(2) 4x10	THA422-2	14	7 1/4	22 11/16	9 3/4	2	—	4-16d	4-16d	6-16d	—	—	3330	3330	3330	—	2865	2865	2865	170	
(2) 4x10	THA426-2	14	7 1/4	26 1/16	9 3/4	2	—	4-16d	4-16d	6-16d	—	—	3330	3330	3330	—	2865	2865	2865		
FACE MOUNT INSTALLATION																					
2x4	THA29	18	1 3/8	9 1/16	5 1/8	—	9 1/16	—	—	4-10d	560	2125	2310	2350	480	1740	1785	1815	18, F7, L15		
2x6	THA213	18	1 3/8	13 3/16	5 1/2	—	13 3/16	—	4-10d	1170	1940	2000	2030	780	1385	1425	1450				
2x6	THA218	18	1 3/8	17 3/16	5 1/2	—	17 3/16	—	4-10d	1170	1940	2000	2030	780	1385	1425	1450				
(2) 2x10	THA218-2	16	3 3/8	17 1/16	8	—	14 1/16	—	22-16d	1855	3695	3695	3695	1595	3185	3185	3185				
(2) 2x10	THA222-2	16	3 3/8	22 3/16	8	—	14 1/16	—	22-16d	1855	3695	3695	3695	1595	3185	3185	3185				
4x6	THA413	18	3 3/8	13 3/16	4 1/2	—	13 3/16	—	4-10d	1170	1940	2235	2400	780	1660	1910	2075				
4x10	THA418	16	3 3/8	17 1/2	7 7/8	—	14 1/16	—	22-16d	1855	3695	3695	3695	1595	3185	3185	3185				
4x10	THA422	16	3 3/8	22	7 7/8	—	14 1/16	—	22-16d	1855	3695	3695	3695	1595	3185	3185	3185				
4x10	THA426	14	3 3/8	26	7 7/8	—	16 1/16	—	30-16d	1855	4550	4550	4550	1595	3915	3915	3915	F23			
(2) 4x10	THA422-2	14	7 1/4	22 11/16	9 3/4	—	16 3/16	—	30-16d	1855	5160	5520	5520	1595	4440	4745	4745	170			
(2) 4x10	THA426-2	14	7 1/4	26 1/16	9 3/4	—	18	—	38-16d	1855	5520	5520	5520	1595	4440	4745	4745				

1. 16d sinkers may be used to replace 16d commons at 0.85 of table load.
 2. Uplift has been increased for wind or earthquake loading with no further increase allowed; reduce where other loads govern.
 3. Roof loads are 125% of floor loads unless limited by other criteria.
 4. THAR/L422 with 4-10d top nails and 2-10d face nails: When the hanger height is between 9' to 12', the allowable download is 1440 lbs. for DFL and 1210 lbs. for SPF. No further increase allowed.

5. For top flange installation on a nailer (see detail above), install joist nails straight by bending the double shear tabs.
 6. For single 2x and 3x nailers, the following THA hangers can be installed using 10dx1 1/2" top nails and 2-16d face nails with reduced allowable loads as noted: THA418/THA422: 1415 lbs. for DFL, 1215 lbs. for SPF; THA426: 2245 lbs. for DFL, 1930 lbs. for SPF.
 7. Min. Top Flange refers to the minimum length of strap that must be field-formed over the header.
 8. NAILS: 16d = 0.162" dia. x 3 1/2" long, 16dx2 1/2" = 0.162" dia. x 2 1/2" long, 10d = 0.148" dia. x 3" long, 10dx1 1/2" = 0.148" dia. x 1 1/2" long. See pages 22-23 for other nail sizes and information.

HFN/F Panelized Construction Hangers

The HF24N, HF26N, HF34N and HF36N hangers are designed for panels or components using jigs or similar devices for precision fabrication. Grip-groove feature provides positive lock into the 2x or 3x member without nailing. F series panel hangers are engineered components for panelized construction only.

MATERIAL: 18 gauge

FINISH: Galvanized. Some products available in ZMAX® coating; see Corrosion Information, pages 13-15.

STANDARD INSTALLATION:

- Use all specified fasteners in pre-manufactured holes. See General Notes.
- On the F-series hanger, the diamond hole nail is non-structural and does not contribute to the load.
- For additional information on retrofit options see flier F-RUZRNUZ.

PANELIZED INSTALLATION:

- **Installing two nails through sheathing in middle of hanger achieves full load. See illustrations for fastener location requirements. See T-HFHANGER for alternate nailing and allowable load adjustments.**

CODES: See page 12 for Code Reference Key Chart.

These products are available with additional corrosion protection. Additional products on this page may also be available with this option, check with Simpson Strong-Tie for details.

Model No.	Joist Size	Dimensions			Header Fasteners	Allowable Roof Loads (115/125)	Code Ref.
		W	H	TF			
HF24N	2x4	1 ¹ / ₁₆	3 ³ / ₈	1 ¹ / ₄	2-10dx2 ¹ / ₈	580	115, L7
F26P	DISCONTINUED - See HF26N						
HF26N	2x6	1 ¹ / ₁₆	5 ³ / ₈	1 ¹ / ₄	2-10dx2 ¹ / ₈	635	
HF34N	3x4	2 ⁵ / ₁₆	3 ³ / ₈	1 ¹ / ₄	2-10dx2 ¹ / ₈	690	
HF36N	3x6	2 ⁵ / ₁₆	5 ³ / ₈	1 ¹ / ₄	2-10dx2 ¹ / ₈	725	
F24-2	(2) 2x4	3 ¹ / ₄	3 ¹⁵ / ₃₂	1 ³ / ₈	2-10d	735	
F26-2	(2) 2x6	3 ¹ / ₄	5 ³ / ₈	1 ³ / ₁₆	2-10d	800	
F44	4x4	3 ³ / ₁₆	3 ⁷ / ₁₆	1 ¹ / ₂	2-10d	880	
F46	4x6	3 ³ / ₁₆	5 ³ / ₈	1 ⁷ / ₁₆	2-10d	785	

1. 10d common nails can be used for specified 10dx2¹/₈ nails.
2. See technical bulletin T-HFHANGER for additional applications and loads.
3. **NAILS:** 10d = 0.148" dia. x 3" long, 10dx2¹/₈ = 0.148" dia. x 2¹/₈" long. See pages 22-23 for other nail sizes and information.

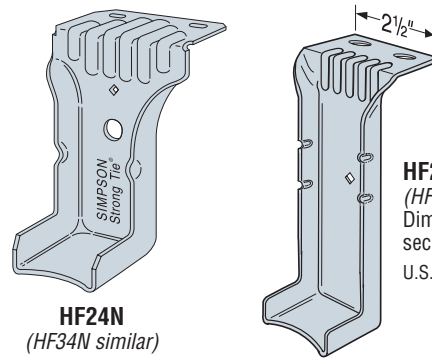

HF24N
(HF34N similar)
U.S. Patent 6,260,402

HF26N
(HF36N similar)
Dimples hold joist securely in place
U.S. Patent 6,260,402

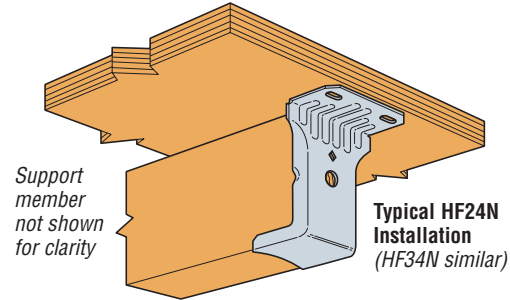

Support member not shown for clarity

Typical HF24N Installation
(HF34N similar)

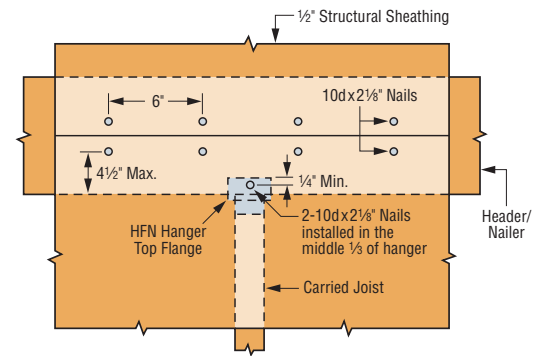

HFN Panelized Installation
(Plan View)

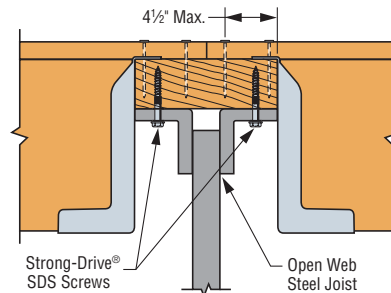

Double HF26N Nailer Installation on Hybrid Truss

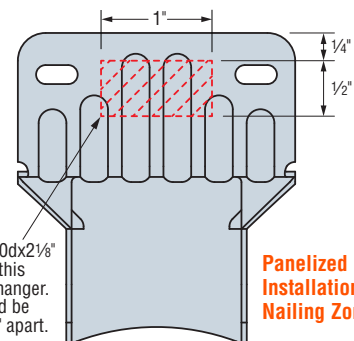

Install 2-10dx2¹/₈" nails thru this region of hanger. Nail should be at least 1/2" apart.

Panelized Installation Nailing Zone

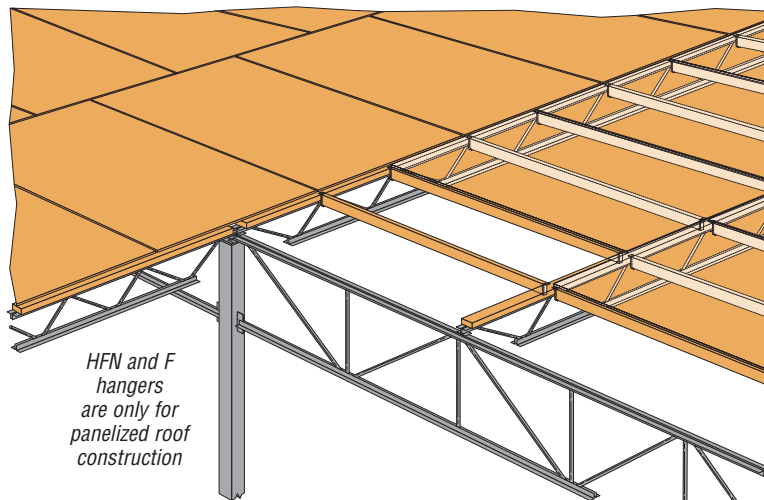

HFN and F hangers are only for panelized roof construction

Typical Hybrid Panelized Roof System

FACE MOUNT HANGERS HU/HUC/HUCQ/HGUS *Glulam Beam & Double Shear Joist Hangers*

See Hanger Options on pages 233-243 for hanger modifications, which may result in reduced loads.

HU/HUC—Most models have triangle and round holes. To achieve maximum loads, fill both round and triangle holes with common nails.

HGUS—Face mount hanger used for high load applications. All hangers in this series have double shear nailing. This innovation distributes the load through two points on each joist nail for greater strength. It also allows the use of fewer nails, faster installation, and the use of common nails for all connections.

HUCQ—Heavy duty joist hangers that incorporate Simpson Strong-Tie® Strong Drive® SDS Heavy-Duty Connector screws.

MATERIAL: See tables **FINISH:** Galvanized. Some products available in ZMAX® or HDG coating; see Corrosion Information, pages 13-15.

INSTALLATION: • Use all specified fasteners. See General Notes.

- HU/HUC—can be installed filling round holes only, or filling round and triangle holes for maximum values.
- HGUS—Nails must be driven at an angle through the joist or truss into the header to achieve the table loads.
- HUCQ—Install ¼"x2½" Strong-Drive SDS Heavy-Duty Connector screws (provided) in all round holes. Lag screws will not achieve the same load.
- With 3x carrying members, use 16d x 2½" (0.162" dia. x 2½" long) nails into the header and 16d commons into the joist with no load reduction. With 2x carrying members, use 10d x 1½" (0.148" dia. x 1½" long) nails into the header and 10d commons into the joist, and reduce the load to 0.64 of the table value.
- For installations to masonry or concrete, see page 175.

OPTIONS: • HU hangers available with the header flanges turned in for 2¾" and larger widths, with no load reduction—order HUC hanger.

- See Hanger Options on pages 233-243, for sloped and/or skewed HU models, and HUC (concealed flange) models.
- Concealed flanges are not available for HGUS.
- HGUS may be skewed only up to a maximum of 45°. See Hanger Options page 237 for load reductions.
- Other sizes available; contact Simpson Strong-Tie.
- See also HUS series.
- HUCQ hangers cannot be modified.

CODES: See page 12 for Code Reference Key Chart.

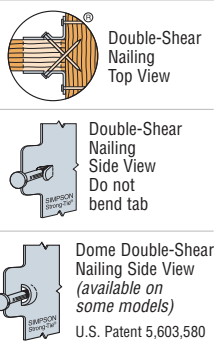
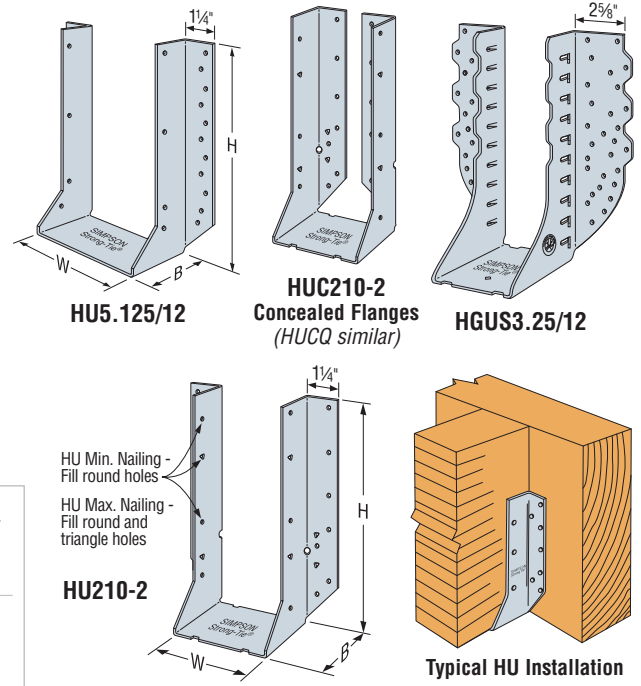

Projection seat on most models for maximum bearing and section economy. Model configurations may differ from those shown. Some HU models do not have triangle holes. Contact Simpson Strong-Tie for details.

These products are available with additional corrosion protection. Additional products on this page may also be available with this option, check with Simpson Strong-Tie for details.

Carried Member Width	Model No.	Ga	Dimensions (in.)				Fasteners		Allowable Loads						Code Ref.	
			W	H	B	Min/Max	Face	Joist	DF/SP Species Header			SPF/HF Species Header				
									Uplift (160)	Floor (100)	Snow (115)	Roof (125)	Floor (100)	Snow (115)		Roof (125)
3/8" GLULAM	HU210-2/HUC210-2	14	3 3/8	8 1/8	2 1/2	Min	14-16d	6-10d	1135	2085	2350	2530	1795	2025	2180	I9, F6, L17, L12
	HU212-2/HUC212-2		3 3/8	8 1/8	2 1/2	Max	18-16d	10-10d	1895	2680	3020	3250	2305	2605	2800	
	HU3.25/10.5/HUC3.25/10.5	14	3 3/8	10 1/4	2 1/2	—	22-16d	10-10d	1135	2380	2685	2890	2050	2315	2490	I9, L12
	HU3.25/12/HUC3.25/12		3 3/8	10 1/4	2 1/2	—	24-16d	12-10d	1895	3275	3695	3970	2820	3180	3425	
	HU216-2/HUC216-2	12	3 3/8	13 3/8	2 1/2	Min	20-16d	8-10d	1515	2975	3360	3610	2565	2895	3110	I9, F6, L17, L12
	HU3.25/16/HUC3.25/16		3 3/8	13 3/8	2 1/2	Max	26-16d	12-10d	2015	3870	4365	4695	3330	3760	4045	
	HUCQ210-2-SDS		3 3/8	9	3	—	12-SDS 1/4"x2 1/2"	6-SDS 1/4"x2 1/2"	2510	4680	4955	4955	3370	3570	3570	
HGUS3.25/10	12	3 3/8	8 3/8	4	—	46-16d	16-16d	4095	9100	9100	9100	7825	7825	7825	I9, F23, L12	
HGUS3.25/12		3 3/8	10 3/8	4	—	56-16d	20-16d	5045	9600	9600	9600	8255	8255	8255		
3 1/2" GLULAM	HU410	14	3 3/8	8 3/8	2 1/2	Max	18-16d	10-10d	1895	2680	3020	3250	2305	2605	2800	I7, I9, F8, L12
	HU414		3 3/8	12 5/8	2 1/2	Max	24-16d	12-10d	2015	3570	4030	4335	3075	3470	3735	
	HUCQ410-SDS	14	3 3/8	9	3	—	12-SDS 1/4"x2 1/2"	6-SDS 1/4"x2 1/2"	2510	4680	4955	4955	3370	3570	3570	I9, F24, L12
	HUCQ412-SDS		3 3/8	11	3	—	14-SDS 1/4"x2 1/2"	6-SDS 1/4"x2 1/2"	2510	5460	5560	5560	3930	4005	4005	
	HHUS410	12	3 3/8	9	3	—	30-16d	10-16d	3735	5635	6380	6880	4835	5480	5910	I7, I9, F8, L12
	HGUS410		3 3/8	9 1/8	4	—	46-16d	16-16d	4095	9100	9100	9100	7825	7825	7825	
	HGUS414		3 3/8	12 1/8	4	—	66-16d	22-16d	5515	10100	10100	10100	8685	8685	8685	
5 1/8" GLULAM	HU310-2/HUC310-2	14	5 1/8	8 3/8	2 1/2	—	14-16d	6-10d	1135	2085	2350	2530	1795	2025	2180	I9, F6, L17, L12
	HU5.125/12/HUC5.125/12		5 1/8	10 1/4	2 1/2	—	22-16d	8-16d	1795	3275	3695	3970	2820	3180	3425	
	HU5.125/13.5/HUC5.125/13.5	14	5 1/8	13 1/4	2 1/2	—	26-16d	12-16d	2695	3870	4365	4695	3330	3760	4045	I9, L12
	HU5.125/16/HUC5.125/16		5 1/8	13 3/8	2 1/2	—	26-16d	12-16d	2695	3870	4365	4695	3330	3760	4045	
	HUCQ5.25/9-SDS	12	5 1/8	9	3	—	12-SDS 1/4"x2 1/2"	6-SDS 1/4"x2 1/2"	2510	4680	4955	4955	3370	3570	3570	I9, F23, L12
	HUCQ5.25/11-SDS		5 1/8	11	3	—	14-SDS 1/4"x2 1/2"	6-SDS 1/4"x2 1/2"	2510	5460	5560	5560	3930	4000	4000	
	HGUS5.25/10		5 1/8	9 1/8	4	—	46-16d	16-16d	4095	9100	9100	9100	7825	7825	7825	
HGUS5.25/12	5 1/8	10 3/8	4	—	56-16d	20-16d	5045	9600	9600	9600	8255	8255	8255			
5 1/2" GLULAM	HUCQ610-SDS	14	5 1/2	9	3	—	12-SDS 1/4"x2 1/2"	6-SDS 1/4"x2 1/2"	2520	4680	5380	5715	3370	3875	4115	I9, F27, L12
	HUCQ612-SDS		5 1/2	11	3	—	14-SDS 1/4"x2 1/2"	6-SDS 1/4"x2 1/2"	2520	5315	5315	5315	3825	3825	3825	
	HHUS5.50/10	12	5 1/2	9	3	—	30-16d	10-16d	3735	5635	6380	6880	4835	5480	5910	I9, F23, L12
	HGUS5.50/10		5 1/2	8 3/8	4	—	46-16d	16-16d	4095	9100	9100	9100	7825	7825	7825	
HGUS5.50/14	5 1/2	12 1/4	4	—	66-16d	22-16d	5515	10100	10100	10100	8685	8685	8685			
6 3/4" GLULAM	HGUS6.88/10	12	6 3/4	8 3/8	4	—	46-16d	16-16d	4095	9100	9100	9100	7825	7825	7825	I9, F23, L12
	HGUS6.88/12		6 3/4	10 3/8	4	—	54-16d	20-16d	5045	9600	9600	9600	8255	8255	8255	
	HGUS6.88/14		6 3/4	12 3/8	4	—	66-16d	22-16d	5515	10100	10100	10100	8685	8685	8685	
7" GLULAM	See HHUS and HGUS in 7" Structural Composite Lumber section, page 116 or GU series on page 117.															
8 3/4" GLULAM	See HGU and HHGU on page 102.															

1. Uplift loads based on Douglas Fir and have been increased 60% for wind or earthquake loading with no further increase allowed. Reduce where other loads govern.
2. MIN nailing quantity and load values—fill all round holes; MAX nailing quantity and load values—fill all round and triangle holes.

3. For SPF/HF uplift, use 0.86 x DF/SP uplift load for products requiring nails and 0.72 for products requiring screws.
4. NAILS: 16d = 0.162" dia. x 3 1/2" long, 10d = 0.148" dia. x 3" long. See pages 22-23 for other nail sizes and information.

LGU/MGU/HGU/HHGU High-Capacity Girder Hangers

The GU hangers are high-capacity girder hangers designed for situations where the header and joist are flush at the top. These products can be used for retrofit on the framing members after they are temporarily placed in position. Simpson Strong-Tie® Strong-Drive® SDS Heavy-Duty Connector screws make installation fast and easy, with no pre-drilling required.

MATERIAL: See table

FINISH: Galvanized, HHGU—Simpson Strong-Tie® gray paint. Available in hot-dip galvanized, order as “X” version and specify HDG.

INSTALLATION: • Use all specified fasteners. See General Notes.

- Install with ¼" x 2½" Strong-Drive SDS Heavy-Duty Connector screws, which are provided with the GUs. (Note: lag screws will not achieve the same loads.)
- All multiple members must be fastened together to act as a single unit.
- Multiple member headers may require additional fasteners at the hanger locations. The quantity and location of the additional fasteners must be determined by the Designer.
- For installation to concrete or masonry walls, see LGUM and HGUM hangers page 176.

OPTIONS:

- Other seat widths available. Order as “X” version, specify width.
- See Hanger Options, pages 233-243, for one flange concealed option. MGU with W 4" or less and HGU with W 4 1/16" or less cannot be concealed.
- LGU, MGU and HGU hangers may be skewed up to 45°. See page 243.

CODES: See page 12 for Code Reference Key Chart.

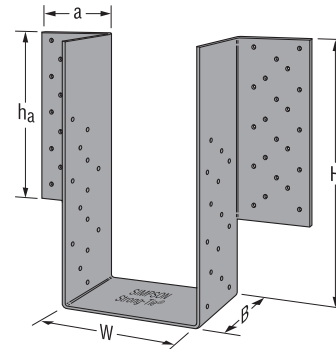

HHGU
(LGU, MGU, HGU similar)

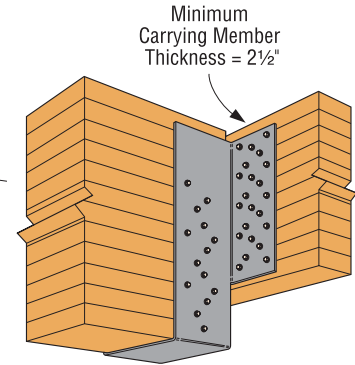

Typical HHGU Installation

Glulam Beam Connectors

These products are available with additional corrosion protection. Additional products on this page may also be available with this option, check with Simpson Strong-Tie for details.

DON'T FEEL LIKE SIFTING THROUGH THIS TABLE?

Visit www.strongtie.com/software to learn more about our new Joist Hanger Selector software.

Actual Carried Beam Width	Model No.	Ga	Dimensions					Fasteners		Allowable Loads				Code Ref.
			W	H ² (min)	B	ha ³	a	Face	Joist	DF/SP		SPF/HF		
										Uplift ¹ (160)	Download (100/115/125)	Uplift ¹ (160)	Download (100/115/125)	
3 3/8	LGU3.25-SDS	10	3 3/4	8	4 1/2	7 3/8	3 3/4	16-SDS 1/4"x2 1/2"	12-SDS 1/4"x2 1/2"	5555	6720	4000	4840	I9, L12, F23
	LGU3.63-SDS	10	3 5/8	8	4 1/2	7 3/8	3 3/4	16-SDS 1/4"x2 1/2"	12-SDS 1/4"x2 1/2"	5555	6720	4000	4840	
3 1/2	MGU3.63-SDS	10	3 5/8	9 1/4	4 1/2	8 5/8	4	24-SDS 1/4"x2 1/2"	16-SDS 1/4"x2 1/2"	7260	9450	5225	6805	I9, L12
	HGU3.63-SDS	7	3 5/8	11	5 1/4	10 3/8	4 3/4	36-SDS 1/4"x2 1/2"	24-SDS 1/4"x2 1/2"	9895	14145	7125	10185	
5 1/8	LGU5.25-SDS	10	5 1/4	8	4 1/2	7 3/8	3 3/4	16-SDS 1/4"x2 1/2"	12-SDS 1/4"x2 1/2"	5555	6720	4000	4840	I9, L12, F23
	MGU5.25-SDS	10	5 1/4	9 1/4	4 1/2	8 5/8	4	24-SDS 1/4"x2 1/2"	16-SDS 1/4"x2 1/2"	7260	9450	5225	6805	
	HGU5.25-SDS	7	5 1/4	11	5 1/4	10 3/8	4 3/4	36-SDS 1/4"x2 1/2"	24-SDS 1/4"x2 1/2"	9895	14145	7125	10185	
5 1/4	MGU5.50-SDS	10	5 1/2	9 1/4	4 1/2	8 5/8	4	24-SDS 1/4"x2 1/2"	16-SDS 1/4"x2 1/2"	7260	9450	5225	6805	I9, L12, F23
	HGU5.50-SDS	7	5 1/2	11	5 1/4	10 3/8	4 3/4	36-SDS 1/4"x2 1/2"	24-SDS 1/4"x2 1/2"	9895	14145	7125	10185	
5 1/2	HHGU5.50-SDS	3	5 1/2	13	5 1/4	12 3/8	4 3/4	44-SDS 1/4"x2 1/2"	28-SDS 1/4"x2 1/2"	14550	17845	10475	12850	I9, L12
	MGU5.62-SDS	10	5 5/8	9 1/4	4 1/2	8 5/8	4	24-SDS 1/4"x2 1/2"	16-SDS 1/4"x2 1/2"	7260	9450	5225	6805	
	HGU5.62-SDS	7	5 5/8	11	5 1/4	10 3/8	4 3/4	36-SDS 1/4"x2 1/2"	24-SDS 1/4"x2 1/2"	9895	14145	7125	10185	
6 3/4	HHGU5.62-SDS	3	5 5/8	13	5 1/4	12 3/8	4 3/4	44-SDS 1/4"x2 1/2"	28-SDS 1/4"x2 1/2"	14550	17845	10475	12850	I9, L12
	MGU7.00-SDS	10	7	9 1/4	4 1/2	8 5/8	4	24-SDS 1/4"x2 1/2"	16-SDS 1/4"x2 1/2"	7260	9450	5225	6805	
8 1/4	HGU7.00-SDS	7	7	11	5 1/4	10 3/8	4 3/4	36-SDS 1/4"x2 1/2"	24-SDS 1/4"x2 1/2"	9895	14145	7125	10185	I9, L12, F23
	HHGU7.00-SDS	3	7	13	5 1/4	12 3/8	4 3/4	44-SDS 1/4"x2 1/2"	28-SDS 1/4"x2 1/2"	14550	17845	10475	12850	
8 3/4	HGU9.00-SDS	7	9	11	5 1/4	10 3/8	4 3/4	36-SDS 1/4"x2 1/2"	24-SDS 1/4"x2 1/2"	9895	14145	7125	10185	I9, L12, F23
	HHGU9.00-SDS	3	9	13	5 1/4	12 3/8	4 3/4	44-SDS 1/4"x2 1/2"	28-SDS 1/4"x2 1/2"	14550	17845	10475	12850	
10 3/4	HHGU11.00-SDS	3	11	13	5 1/4	12 3/8	4 3/4	44-SDS 1/4"x2 1/2"	28-SDS 1/4"x2 1/2"	14550	18480 ⁴	10475	13305 ⁴	170

1. Uplift loads have been increased for wind or earthquake loading with no further increase allowed.
 2. Specify H dimension. Maximum H = 30".
 3. Header height must be at least as tall as the flange height (ha).
 4. Where noted, allowable loads may be increased for duration of load up to 20455 lbs. for DF/SP and 14725 lbs. for SPF/HF.

TOP FLANGE HANGERS HHB/GB/HGB *Beam & Purlin Hangers*

See table on page 105. See Hanger Options on pages 233-243 for hanger modifications, which may result in reduced loads.

This series of beam and purlin hangers may be used for wood to wood or wood to steel applications. Precision forming provides dimensional accuracy and helps ensure proper bearing area and connection.

MATERIAL: See table on page 105

FINISH: HHB, GB, HGB, all saddle hangers and all welded sloped and special hangers—Simpson Strong-Tie® gray paint. May be ordered hot-dip galvanized; specify HDG.

INSTALLATION: • Use specified fasteners. See General Notes.

- HHB, GB and HGB may be used for weld-on applications. The minimum required weld to the top flanges is 3/16" x 2" fillet weld to each side of each top flange tab. Distribute the weld equally on both top flanges. Welding cancels the top and face nailing requirements. Consult the code for special considerations when welding galvanized steel. The area should be well-ventilated. See page 17 for weld information. Weld on applications produce the maximum allowable load listed. Uplift loads do not apply to welded applications.
- Ledgers must be evaluated for each application separately. Check TF dimension, nail length and nail location on ledger.

- OPTIONS:** • HHB—other widths are available; specify W dimension (*the minimum W dimension is 2 1/2"*).
- Saddle hangers are made to order; add "D" to model (*e.g. HHB3D*); specify S (*for saddle*) dimension. They may be used for most conditions except at end wall locations, and are preferred for nailer applications.
 - The coating on special B hangers will depend on the manufacturing process used. Check with your Simpson Strong-Tie representative for details. Hot-dip galvanized available; specify HDG.
 - B dimensions may be increased on some models.
 - See Hanger Options, pages 233-243.

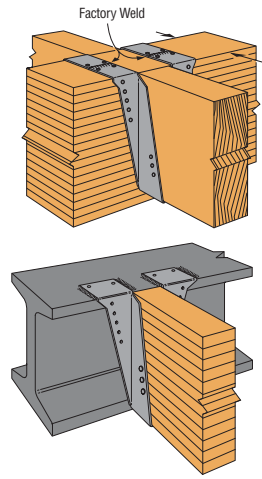

Typical HHB, GB and HGB Saddle Installation

HHB, GB and HGB are acceptable for weld-on applications. See Installation Information.

TOP FLANGE HANGERS WM/WMU/WP/WPU/HW/HWU

The WPU, HWU and HW series purlin hangers offer the greatest design flexibility and versatility.

MATERIAL: WP/WPU—7 ga. top flange, 12 ga. stirrup; HW—3 ga. top flange, 11 ga. stirrup; HWU—3 ga. top flange, 10 ga. stirrup

FINISH: Simpson Strong-Tie gray paint; hot-dip galvanized available; specify HDG.

INSTALLATION: • Hangers may be welded to steel headers with 3/16" for WPU/WP, and 1/4" for HW/HWU, by 1 1/2" fillet welds located at each end of the top flange. Weld-on applications produce maximum allowable load listed. See page 17 for weld information. For uplift loads refer to technical bulletin T-WELDUPLFT.

- Hangers can support multi-ply carried members; the individual members must be secured together to work as a single unit before installation into the hanger.
- **WM/WMU MID-WALL INSTALLATION:** Installed between blocks with duplex nails cast into grout with a minimum of one grouted course above and below the top flange and one #5 vertical rebar minimum 24" long in each adjacent cell.
- **WM/WMU TOP-OF-WALL INSTALLATION:** Install on top of wall to a grouted beam with masonry screws.

OPTIONS: See Hanger Options, pages 233-243, for hanger modifications and associated load reductions.

CODES: See page 12 for Code Reference Key Chart.

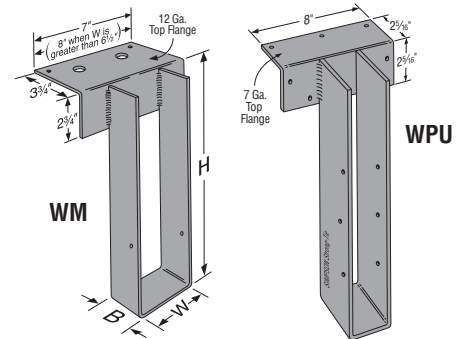

WM

WPU

Some model configurations may differ from those shown. Contact Simpson Strong-Tie for details.

NAILER TABLE

The table indicates the maximum allowable loads for WP, WPU, HW or HWU hanger used on wood nailers. Nailers are wood members attached to the top of a steel I-beam, concrete or masonry wall.

1. Uplift value for the HWU hanger is for depth ≤ 18". Refer to uplift values in table below for taller depths.
2. Attachment of nailer to supporting member is the responsibility of the Designer. See page 25 for TB screws attachment option.

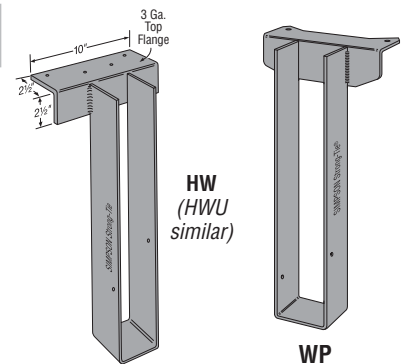

HW (HWU similar)

WP

Model	Nailer	Top Flange Nailing	Allowable Loads			
			Uplift (160)	DF/SP	SPF/HF	LSL
WP	2x	2-10dx1 1/2	—	2525	2500	3375
	2-2x	2-10d	—	3255	3255	—
	3x	2-16dx2 1/2	—	3000	2510	3375
	4x	2-10d	—	3255	3255	—
WPU	2-2x	7-10d	700	3255	—	—
	3x	7-16dx2 1/2	970	3000	—	—
	4x	4-16d	1095	3255	—	—
HW	2-2x	4-10d	—	4845	—	—
	3x	4-16dx2 1/2	—	4860	—	—
	4x	4-16d	—	5285	—	—
HWU	2-2x	8-16dx2 1/2	710	5430	—	—
	3x	8-16dx2 1/2	970	5430	—	—
	4x	8-16d	1160	5430	—	—

Model	Joist		Fasteners			Allowable Loads Header Type							Code Ref.		
	Width	Depth	Top	Face	Joist	Uplift (160)	LVL	PSL	LSL	DF/SP	SPF/HF	I-Joist		Masonry ³	
WM	1 1/2 to 7 1/2	3 1/2 to 30	2-16d DPLX	—	2-10dx1 1/2	—	MID-WALL INSTALLATIONS							4175	IL12, L16
	1 1/2 to 7 1/2	3 1/2 to 30	2-1/4x1 3/4 Titens	—	2-10dx1 1/2	—	TOP OF WALL INSTALLATIONS							3380	
WMU	1 1/2 to 7 1/2	9 to 28	2-16d DPLX	4-1/4x1 3/4 Titens	6-10dx1 1/2	625	MID-WALL INSTALLATIONS							4175	170
	1 1/2 to 7 1/2	9 to 28	2-1/4x1 3/4 Titens	4-1/4x1 3/4 Titens	6-10dx1 1/2	545	TOP OF WALL INSTALLATIONS							3380	
WP	1 1/2 to 7 1/2	3 1/2 to 30	2-10dx1 1/2	—	2-10dx1 1/2	—	2865	3250	—	2500	2000	2030	—	F18, L14	
	1 1/2 to 7 1/2	3 1/2 to 30	2-10d	—	2-10dx1 1/2	—	2525	3250	3650	3255	2525	—	—		
	1 1/2 to 7 1/2	3 1/2 to 30	2-16d	—	2-10dx1 1/2	—	3635	3320	3650	3255	2600	—	—		
WPU	1 3/4 to 5 1/2	7 1/4 to 18	3-16d	4-16d	6-10dx1 1/2	1095	4700	4880	3650	4165	4165	—	—	I19, F18, L14	
	1 3/4 to 5 1/2	18 1/2 to 28	3-16d	4-16d	6-10dx1 1/2	390	4700	4880	3650	4165	4165	—	—		
HW	1 1/2 to 7 1/2	3 1/2 to 32	4-10d	—	2-10dx1 1/2	—	3100	4000	—	5285	3100	—	—	I10, I19, F9, F18, L11, L14	
	1 1/2 to 7 1/2	3 1/2 to 32	4-16d	—	2-10dx1 1/2	—	5100	4000	4500	5285	3665	—	—		
HWU	1 3/4 to 3 1/2	9 to 18	4-16d	4-16d	6-10dx1 1/2	1160	6335	5500	5535	6335	5415	—	—	I19, F18, L11, L14	
	1 3/4 to 3 1/2	18 1/2 to 28	4-16d	4-16d	6-10dx1 1/2	965	6335	5500	5535	6335	5415	—	—		
	1 3/4 to 3 1/2	28 1/2 to 32	4-16d	4-16d	8-10dx1 1/2	985	6335	5500	5535	6335	5415	—	—		
	4 1/2 to 7	9 to 18	4-16d	4-16d	6-10dx1 1/2	1160	6000	5500	5535	6000	5415	—	—		
	4 1/2 to 7	18 1/2 to 28	4-16d	4-16d	6-10dx1 1/2	965	6000	5500	5535	6000	5415	—	—		
	4 1/2 to 7	28 1/2 to 32	4-16d	4-16d	8-10dx1 1/2	985	6000	5500	5535	6000	5415	—	—		

1. 16d sinkers (0.148" dia x 3 3/4" long) may be used where 10d commons are called out with no load reduction.
2. Uplift loads are based on DF/SP lumber and have been increased for wind or earthquake loading with no further increase allowed. Reduce where other loads govern.
3. Minimum f_m = 1500 psi. See Installation Notes on page 173.
4. For hanger heights exceeding the joist height, the allowable load is 0.50 of the table load.
5. **NAILS:** 16d = 0.162" dia x 3 1/2" long, 10d = 0.148" dia x 3" long, 10dx1 1/2 = 0.148" dia x 1 1/2" long. See pages 22-23 for other nail sizes and information.

TOP FLANGE HANGERS GLS/HGLS/GLT/HGLT *Beam & Glulam Saddle Hangers*

See table on page 105. See Hanger Options on pages 233-243 for hanger modifications, which may result in reduced loads.

GLT and HGLT accommodate typical structural requirements for timber and glulam beams. GLT top flange depth allows installation on minimum 4x ledger (*3 1/2" net*). Not acceptable for nailer applications. Funnel Flanges® allow easy installation of beams.

GLS and HGLS are heavy glulam saddle hangers.

MATERIAL: All welded GL series glulam hangers have a 3 gauge top flange. See page 105 for stirrup gauge.

FINISH: Simpson Strong-Tie® gray paint. Hot-dip galvanized available; specify HDG.

INSTALLATION: • Use all specified fasteners. See General Notes.

GLT/HGLT:

- All GLTs used with sawn timbers have a 12" L dimension.
- Fasteners are included.
- GLT may be attached to steel headers by 3/16" x 2 1/2" fillet welds at each end of the header angle to obtain the tabulated loads. HGLT may be attached to steel headers by 1/4" x 2 1/2" fillet welds at each end of the header angle to obtain the lesser of the tabulated loads or 12,000 lbs. For uplift loads refer to technical bulletin T-WELDUPLFT. See page 17 for weld information.
- Not for use with SCL or LVL headers. See GLTV, HGLTV.

GLS/HGLS:

- Use Simpson Strong-Tie® 1/4" x 2 1/2" SDS Heavy-Duty Connector screws when hangers are used with structural composite lumber.
- N54A nails are included with the hangers.
- Loads listed are per stirrup.

TO ORDER: • GLS/HGLS—Specify H₁, H₂, and S dimensions (see illustration).

- Some engineered wood sizes are also available.

OPTIONS: See Hanger Options pages 233-243.

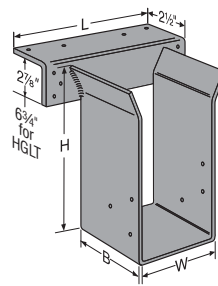

GLT
(HGLT similar)
(fasteners included)

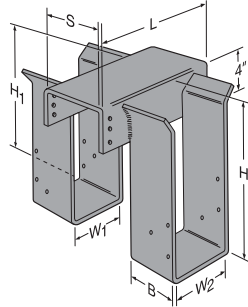

GLS
(fasteners included)

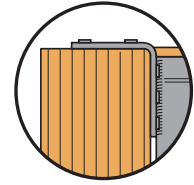

Flatten edge of header to match top flange radius.

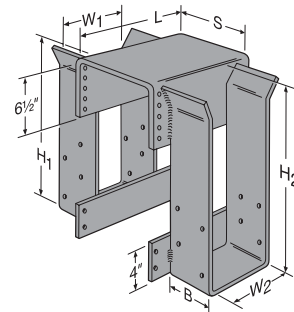

HGLS
(fasteners included)

Model	Stirrup Width (W)	Top Flange Length (L)
GLT	2 5/8 - 5 1/2	10
	5 9/16 - 6 7/8	12
HGLT	2 5/8 - 8 1/4	12
	8 7/8	14
GLS	3 1/4 - 5 3/8	9
	6 7/8	12
HGLS	5 1/4 - 8 7/8	12

Glulam Beam Connectors

TOP FLANGE HANGERS LEG/MEG/EG *Beam & Glulam Hangers*

See Hanger Options on pages 233-243 for hanger modifications, which may result in reduced loads.

Designed to support large members typically found in glulam beam construction.

MATERIAL: See table

FINISH: Simpson Strong-Tie gray paint. Hot-dip galvanized available; specify HDG.

INSTALLATION: • Use all specified fasteners. See General Notes.

- Maintain minimum 4D end distance and edge distance from bolt to end of header and nearest loaded edge per NDS requirements.

OPTIONS: • See Hanger Options, pages 233-243.

- Models available without top flanges; see table loads.

CODES: See page 12 for Code Reference Key Chart.

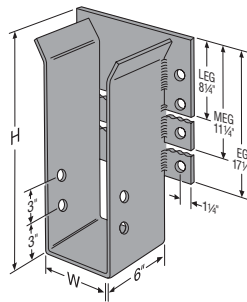

LEG/MEG/EG
without Top Flange
(see options)

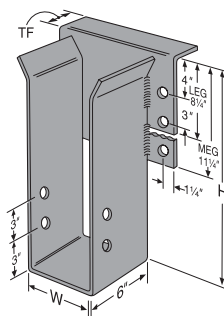

LEG and MEG

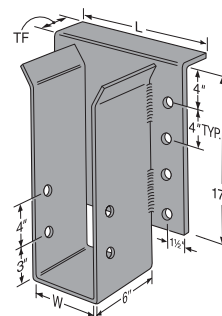

EG

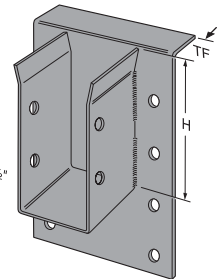

EG with "H" dimension less than the face plate height. The EG's back plate is always 17 1/2", regardless of the stirrup height.

These products are available with additional corrosion protection.

Joist or Purlin Size	Model No.	Stirrup Ga	Dimensions				Bolts				Allowable Loads				Code Ref.		
			W	Min ³ H	TF	Min. Header Depth	Header		Joist		Without Top Flange		Top Flange No Triangle Theory			Top Flange Triangle Theory	
							Qty	Dia	Qty	Dia	Floor (100)	Roof (125)	Floor (100)	Roof (125)		Floor (100)	Roof (125)
3 1/2" LAM	LEG3	7	3 1/4	9	2 1/2	10	4	3/4	2	3/4	3465	4330	12675	13215	13040	13865	I19, F18, L14
	LEG5	7	5 1/4	9	2 1/2	10	4	3/4	2	3/4	3465	4330	16290	16290	13040	13865	
5 1/2" LAM	MEG5	7	5 1/4	9	2 1/2	13	6	3/4	2	3/4	5170	6460	19710	19710	14835	16860	
	EG5	7	5 1/4	11	2 1/2	20	8	1	2	1	8870	11085	20895	21815	17885	19865	
6 1/2" LAM	LEG7	7	6 7/8	9	2 1/2	10	4	3/4	2	3/4	3465	4330	16290	16290	13040	13865	
	MEG7	7	6 7/8	9	2 1/2	13	6	3/4	2	3/4	5170	6460	19710	19710	14885	16060	
8 1/2" LAM	EG7	7	6 7/8	11	2 1/2	20	8	1	2	1	8870	11085	25320	25835	19290	21275	
	EG9	7	8 7/8	11	2 1/2	20	8	1	2	1	8870	11085	25320	25835	20080	22875	

Model	Top Flange Ga	Top Flange Length (L)
LEG/MEG	7	12
EG5	3	11 1/4
EG7		13 1/2
EG9		15 1/2

1. Roof loads are 125% of floor loads unless limited by other criteria.
2. Allowable loads assume a carrying member width of 5 1/2".
3. Specify H dimension.
4. Triangle Theory: Some code jurisdictions allow only half of the top flange bearing area to be considered when performing a top flange hanger calculation as there is non-uniform stress under the top flange (presumed to be a triangular shaped distribution). Therefore, loads are published above using the calculated "Triangle Theory". Loads are also published in the "No Triangle Theory" columns which are based on calculations assuming full bearing on the top flange which do not exceed the tested value with a reduction factor of 3.

TOP FLANGE HANGERS – GLULAM BEAM

These products are available with additional corrosion protection.

Glulam Beam Connectors

Joist or Purlin Size	Model No.	Ga	Dimensions				Fasteners		Allowable Loads				Code Ref.
			W	H	B	TF	Header	Joist	Uplift (160)	Floor (100)	Snow (115)	Roof (125)	
3½ LAM	GLT3	7	3¼	7½ MIN	5	2½	10-N54A	6-N54A	1865	8165	8165	8165	I19, F18, L14
	HGLT3	7	3¼	7½ MIN	6	2½	18-N54A	6-N54A	1865	12265	12685	12750	
	GLS3-5 ⁸	7	3¼	8½ MIN	5	5¼	6-N54A	6-N54A	1865	11555	11695	11785	
	GLS3-7 ⁸	7	3¼	8½ MIN	5	6%	6-N54A	6-N54A	1865	11555	11695	11785	
	GLS3-9 ⁸	7	3¼	8½ MIN	5	8%	6-N54A	6-N54A	1865	11555	11695	11785	I10, F9, L11
	HW3.25	11	3¼	5 MIN	4	2½	4-10d	2-10d	—	5285	5285	5285	
	HHB3	7	3¼	7½ MIN	3	2½	10-N54A	6-N54A	1950	6085	6225	6235	
	GB3	7	3¼	7½ MIN	3½	2½	14-N54A	6-N54A	1950	7795	8030	8185	
	HU3.25/12TF	12	3¼	12	2½	2½	16-16d	6-10d	1125	4310	4335	4335	170
	HU3.25/16.5TF	12	3¼	16½	2½	2½	20-16d	8-10d	1500	4860	5275	5545	
3½ LAM	GLT4	7	3¾	7½ MIN	5	2%	10-N54A	6-N54A	1865	8165	8165	8165	I19, F18, L14
	HGLT4	7	3¾	7½ MIN	6	2%	18-N54A	6-N54A	1865	12265	12685	12750	
5½ LAM	GLT5	7	5¼	7½ MIN	5	2½	10-N54A	6-N54A	1865	8165	8165	8165	I19, F18, L14
	HGLT5	7	5¼	7½ MIN	6	2½	18-N54A	6-N54A	1865	12265	12685	12750	
	GLS5-5 ⁸	7	5¼	8½ MIN	5	5¼	6-N54A	6-N54A	1865	14685	14685	14685	
	GLS5-7 ⁸	7	5¼	8½ MIN	5	6%	6-N54A	6-N54A	1865	14685	14685	14685	
	HGLS5 ⁸	7	5¼	10½ MIN	6	SPEC	14-N54A	8-N54A	2500	16835	16835	16835	I10, F9, L11
	HW5.25	11	5¼	5 MIN	2½	2½	4-10d	2-10d	—	5285	5285	5285	
	HHB5	7	5¼	7½ MIN	3	2½	10-N54A	6-N54A	1950	6085	6225	6235	I19, F18, L14
	GB5	7	5¼	7½ MIN	3½	2½	14-N54A	6-N54A	1950	7795	8030	8185	
	HGB5	7	5¼	7½ MIN	4	2½	14-N54A	6-N54A	1950	8580	8815	8970	170
	HU5.25/12TF	12	5¼	12	2½	2½	16-16d	6-16d	1325	4310	4335	4335	
HU5.25/16.5TF	12	5¼	16½	2½	2½	20-16d	8-16d	1765	4860	5275	5550		
5½ LAM	GLT6	7	5¾	7½ MIN	5	2%	10-N54A	6-N54A	1865	8165	8165	8165	I19, F18, L14
	HGLT6	7	5¾	7½ MIN	6	2%	18-N54A	6-N54A	1865	12265	12685	12750	
6¾ LAM	HHB7	7	6%	7½ MIN	3	2½	10-N54A	6-N54A	1950	6085	6225	6235	I19, F18, L14
	GB7	7	6%	7½ MIN	3½	2½	14-N54A	6-N54A	1950	7795	8030	8185	
	HGB7	7	6%	7½ MIN	4	2½	14-N54A	6-N54A	1950	8580	8815	8970	
	GLT7	7	6%	7½ MIN	5	2½	10-N54A	6-N54A	1865	8165	8165	8165	
	HGLT7	7	6%	7½ MIN	6	2½	18-N54A	6-N54A	1865	12265	12685	12750	
	GLS7-7 ⁸	7	6%	8½ MIN	5	6%	6-N54A	6-N54A	1865	14685	14685	14685	
	GLS7-9 ⁸	7	6%	8½ MIN	5	8%	6-N54A	6-N54A	1865	14685	14685	14685	
HGLS7 ⁸	7	6%	10½ MIN	6	SPEC	14-N54A	8-N54A	2500	16835	16835	16835		
7 LAM	HGLT7.12	7	7%	7½ MIN	6	2%	18-N54A	6-N54A	1865	12265	12685	12750	I19
8¾ LAM	HGLT9	7	8%	7½ MIN	6	2½	18-N54A	6-N54A	1865	12750	12750	12750	I19, F18, L14
	HGLS9 ⁸	7	8%	10½ MIN	6	SPEC	14-N54A	8-N54A	2500	16835	16835	16835	

- N54A fasteners are supplied with hangers. For GLS and HGLS saddle hangers only, Simpson Strong-Tie® ¼" x 2½" Strong-Drive® SDS Heavy-Duty Connector screws (sold separately) may be substituted using full table loads.
- Uplift loads have been increased for wind or earthquake loading with no further increase allowed. Reduce where other loads govern.
- GLT, HGLT, GLS, HGLS uplift loads only apply when "H" is 28" or less.
- Allowable loads for glulam sizes are based on 650 psi wood bearing.
- "Min H" is the minimum H dimension that may be specified. For GLT, HGLT, GLS, HGLS hanger heights that exceed the joist height, allowable load is 0.50 of the table load.
- Allowable loads are shown for each stirrup.
- GLS, HGLS fasteners listed are for one side only. Fasteners supplied are for both sides of the saddle.
- SPEC: Specify the header dimensions for the saddle hangers. ("S" dimension is illustrated on page 104.)
- NAILS:** 16d = 0.162" dia. x 3½" long, 10d = 0.148" dia. x 3" long, N54A = 0.250" dia. x 2½" long - annular ring. See pages 22-23 for other nail sizes and information.

CODES: See page 12 for Code Reference Key Chart.

GLB/HGLB/GLBT Beam Seats

The GLB Series provides a connection between beam and concrete or CMU pilaster.

FINISH: Simpson Strong-Tie® gray paint. Hot-dip galvanized available. Specify HDG.

INSTALLATION:

- Use all specified fasteners. See General Notes.
- Bolt holes in wood shall be a minimum of 1/32" to a maximum of 1/16" larger than the bolt diameter (per the 2012 NDS, section 11.1.3.2).
- Check the rebar spacing requirements on all installations.

OPTIONS:

- Beam seats for sawn timber and other sizes may be ordered by specifying special dimensions; use the letter designations shown on the illustrations.
- Specify if two-bolt GLB model is desired; see illustration.

CODES: See page 12 for Code Reference Key Chart.

These products are available with additional corrosion protection. Additional products on this page may also be available with this option, check with Simpson Strong-Tie for details.

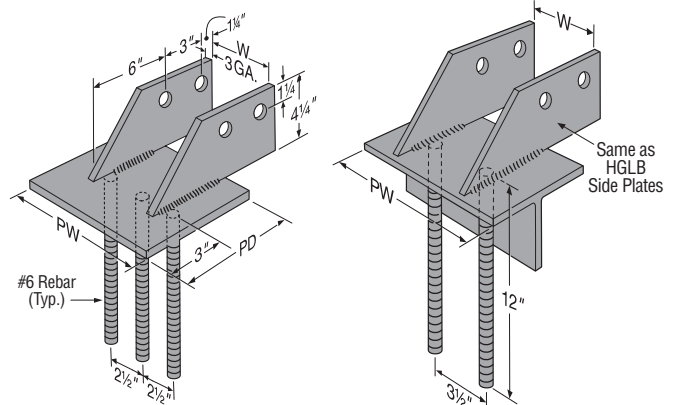

HGLB

GLBT

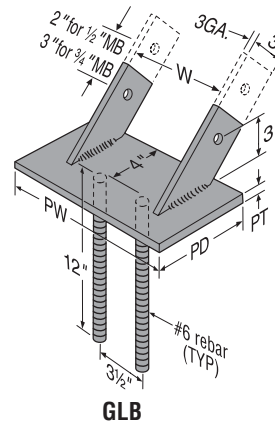

GLB

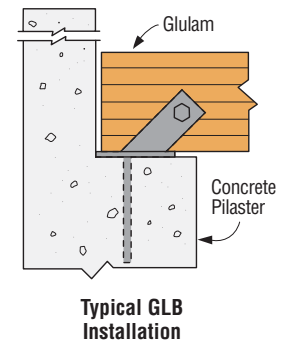

Model No.	Dimensions				Bolts	Allowable Bearing Loads ^{1,2}		Code Ref.
	W	PD	PW	PT		Masonry @ 375 psi	Wood f _c -perp	
GLB5A	5 1/4	5	7	3 ga	1 - 1/2	13125	16655	I20, L10, L16, F19
GLB5B	5 1/4	6	7	3/8	1 - 1/2	15750	19990	
GLB5C	5 1/4	7	7	3/8	1 - 1/2	18375	23320	
GLB5D	5 1/4	8	7	3/8	1 - 1/2	21000	26650	
GLB7A	6 3/8	5	9	3 ga	1 - 3/4	16875	21940	
GLB7B	6 3/8	6	9	3/8	1 - 3/4	20250	26325	
GLB7C	6 3/8	7	9	3/8	1 - 3/4	23625	30715	
GLB7D	6 3/8	8	9	3/8	1 - 3/4	27000	35100	

1. Allowable bearing stress for masonry is based on an f_m of 1500 psi using the IBC (ACI 530 2.1.9.3) Allowable Stress Design. Wood bearing is based on f_c-perp of 650 psi.
2. When installed on masonry, use the lesser of the masonry or the wood allowable load values. When installed on concrete, a minimum f_c = 2500 psi shall be used and use the wood values as the limiting allowable bearing load values.
3. Allowable horizontal loads are bolt values and include increase for wind or earthquake loading. Loads must be reduced if stresses in masonry or concrete are limiting.
4. Beams must fully bear on base plate.
5. The GLBT5 has a WT4x9 structural tee; the GLBT6 has a WT4x12 structural tee.
6. Specify "W" dimension when ordering.
7. Uplift loads do not apply for this connector.

Model No.	Dimensions (in.)				Bolts (Qty.-Dia.)	Allowable Bearing Loads ^{1,2}					Allowable Horizontal Bolt Loads ^{3,4}	Code Ref.	
	Width for Beam (W)	Bearing Plate				Masonry Bearing @ 375 psi	Wood Bearing @ 650 psi on Glulam Width						
		Depth PD	Width PW	Thickness PT			Glulam Beam Width (in.)						
HGLBA	3 1/4 to 9	5	10	3/8	2 - 3/4	18750	10155	16655	21940	28440	—	8260	I20, L10, L16, F19
HGLBB		6	10	3/8	2 - 3/4	22500	12190	19990	26325	34125	—	8260	
HGLBC		7	10	3/8	2 - 3/4	26250	14220	23320	30715	39815	—	8260	
HGLBD		8	10	3/8	2 - 3/4	30000	16250	26650	35100	45500	—	8260	
GLBT512	3 1/4 to 11	5 1/4	12	5/16	2 - 3/4	23625	10665	17490	23035	29860	36685	8260	
GLBT612		6 1/2	12	3/8	2 - 3/4	29250	13205	21655	28520	36970	45420	8260	
GLBT516	3 1/4 to 15	5 1/4	16	5/16	2 - 3/4	31500	10665	17490	23035	29860	36685	8260	
GLBT616		6 1/2	16	3/8	2 - 3/4	39000	13205	21655	28520	36970	45420	8260	
GLBT520	3 1/4 to 19	5 1/4	20	5/16	2 - 3/4	39375	10665	17490	23035	29860	36685	8260	
GLBT620		6 1/2	20	3/8	2 - 3/4	48750	13205	21655	28520	36970	45420	8260	

1. Allowable bearing stress for masonry is based on an f_m of 1500 psi using the IBC (ACI 530) Allowable Stress Design. Wood bearing is based on f_c-perp of 650 psi.
2. When installed on masonry, use the lesser of the masonry or the wood allowable load values. When installed on concrete, a minimum f_c = 2500 psi shall be used and use the wood values as the limiting allowable bearing load values.
3. Allowable horizontal loads are bolt values and include increase for wind or earthquake loading. Loads must be reduced if stresses in masonry or concrete are limiting.
4. Beams must fully bear on base plate.
5. The GLBT5 has a WT4x9 structural tee; the GLBT6 has a WT4x12 structural tee.
6. Specify "W" dimension when ordering.
7. Uplift loads do not apply for this connector.

HCA Hinge Connectors

Hinge connectors are designed to transfer loads between two beams aligned end-to-end through a combination of bearing plates, side plates and bolts. In addition to supporting vertical loads, hinge connectors can also be specified with additional slotted bolt holes to resist horizontal loads as part of a continuous load path.

MATERIAL: Side plates—7 gauge; Top and bottom plates—see PT dimensions in table.

FINISH: Simpson Strong-Tie® gray paint

INSTALLATION: • Use all specified fasteners. See General Notes.

- Bolt holes shall be a minimum of 1/32" and a maximum of 1/16" larger than the bolt diameter (per 2012 NDS 11.1.2.2).
- The model size (suffix) column in the Allowable Download Table gives the basic HCA model with two rotation bolts.
- Contact Simpson Strong-Tie for heights greater than 60".
- Position 3/4" dia. machine bolts in slots away from bearing seat to allow for wood shrinkage.

OPTIONS: The Horizontal Load Table gives other bolt options.

ORDERING: • To order, add the width and bearing plate size designation after the model name. Specify the H dimension. For dapped beams, reduce the H dimension by the PT dimension for each dap.

- Specify Model No., Model Size, and height H.
- Ordering Example: HC4C3TA5-6 H = 18"

CODES: See page 12 for Code Reference Key Chart.

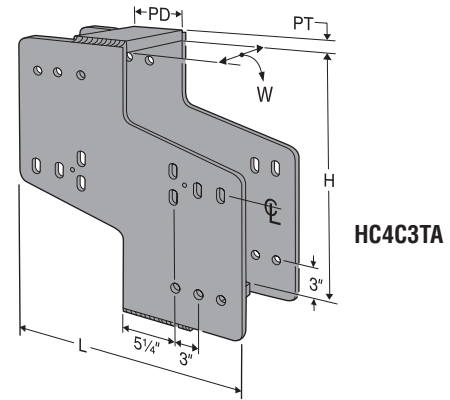

Alternate Installation with Beam Top Non-Dapped

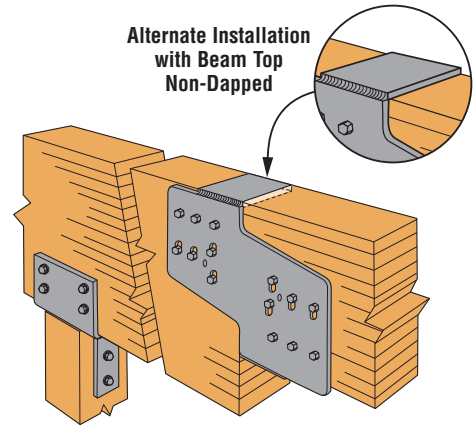

Model No. (Prefix)	L	H ³ Min	H Max	Rotation Bolts Per Beam	Slotted Tension Bolts	Allowable Horizontal Loads ^{2,3}
						(160)
HCA	19 1/2	8	60	2	—	—
HC2CTA	19 1/2	14	60	2	2	9920
HCCTA	19 1/2	14	60	2	3	14850
HC4CTA	25 1/2	14	60	2	4	19720
HC3A	25 1/2	8	60	3	—	—
HCC3TA	25 1/2	14	60	3	3	14850
HC4C3TA	25 1/2	14	60	3	4	19720

1. Loads have been increased for wind or earthquake loading with no further increase allowed.
2. Horizontal loads are for Doug Fir-larch glulams minimum W = 3 1/8". For other wood types, adjust the load according to the code.
3. H MIN is the absolute minimum height. Reduce downloads according to footnote 1 in the Allowable Download Table.

Allowable Download Table

Model Size (Suffix)	Dimensions (in.)				Bolt Dia. (in.)	Two Rotation Bolts Per Beam				Three Rotation Bolts Per Beam				Code Ref.
	Beam Width	W	PT	PD		H ₁	H ₁ Allowable Roof Loads	Min H	Min H Allowable Roof Loads	H ₁	H ₁ Allowable Roof Loads	Min H	Min H Allowable Roof Loads	
3-5	3 1/2	3 3/4	3/4	5	3/4	12	8750	8	3070	10	8750	8	4465	170
3-6	3 1/2	3 3/4	3/4	6	3/4	15	10500	12	7100	12	10500	10	7120	
3-7	3 1/2	3 3/4	3/4	7	3/4	18	12250	15	9240	14	12250	12	9235	
5-5	5 1/2	5 1/4	3/4	5	3/4	16	14350	8	3100	13	14350	8	4560	
5-6	5 1/2	5 1/4	3/4	6	3/4	20	17220	16	12345	16	17220	13	12195	
5-7	5 1/2	5 1/4	3/4	7	3/4	25	20090	20	14835	19	20090	16	15505	
5-9	5 1/2	5 1/4	3/4	9	3/4	36	25830	25	16365	27	25830	19	16030	
5.62-5	5 1/2	5 5/8	3/4	5	3/4	18	17190	8	3100	14	17190	8	4640	
5.62-7	5 1/2	5 5/8	3/4	7	3/4	28	24065	19	14495	21	24065	15	15020	
7-5	6 3/4	6 3/8	1	5	3/4	19	18900	8	3100	15	18900	8	4605	
7-6	6 3/4	6 3/8	1	6	3/4	24	22680	19	16405	18	22680	15	17035	
7-7	6 3/4	6 3/8	1	7	3/4	30	26460	24	19850	22	26460	18	19845	
7-9	6 3/4	6 3/8	1	9	3/4	40	29615	30	20905	33	34020	22	20190	
9-5	8 3/4	8 7/8	1 1/4	5	3/4	22	24500	8	3100	17	24500	8	4605	
9-6	8 3/4	8 7/8	1 1/4	6	3/4	29	29400	22	20465	22	29400	17	20275	
9-7	8 3/4	8 7/8	1 1/4	7	3/4	37	34300	29	25455	27	34300	22	26145	
9-9	8 3/4	8 7/8	1 1/4	9	3/4	40	29615	37	27000	40	43975	27	27160	
11-5	10 3/4	10 7/8	1 1/2	5	3/4	26	30100	8	3100	20	30100	8	4605	
11-6	10 3/4	10 7/8	1 1/2	6	3/4	34	36120	26	25805	25	36120	20	26630	
11-7	10 3/4	10 7/8	1 1/2	7	3/4	40	37925	34	31230	32	42140	25	30815	
11-9	10 3/4	10 7/8	1 1/2	9	3/4	40	29615	40	29615	40	43975	32	33630	
3.62-5	3 1/2	3 3/8	3/4	5	3/4	15	13125	8	3100	12	13125	8	4625	
3.62-9	3 1/2	3 3/8	3/4	9	3/4	34	23625	16	8710	25	23625	13	9125	
5.37-5	5 1/4	5 1/8	1	5	3/4	19	19690	8	3100	15	19690	8	4640	
5.37-9	5 1/4	5 1/8	1	9	3/4	40	29605	20	12190	34	35440	16	13040	
7.12-5	7	7 1/8	1 1/4	5	3/4	23	26250	8	3100	18	26250	8	4635	
7.12-9	7	7 1/8	1 1/4	9	3/4	40	29600	24	15670	40	44330	19	16950	

1. Allowable loads have been increased for roof live loads with no further increase allowed. Reduce where other loads govern.
2. Loads are based on 560 psi perpendicular to grain bearing stress.
3. H₁ is the minimum dimension required to achieve full load for the hinge connector. For H dimensions between H₁ and Minimum H, loads may be linearly interpolated.
4. See Horizontal Load Table for models available with three rotation bolts.
5. Beams must be the same width for both members in the connection.

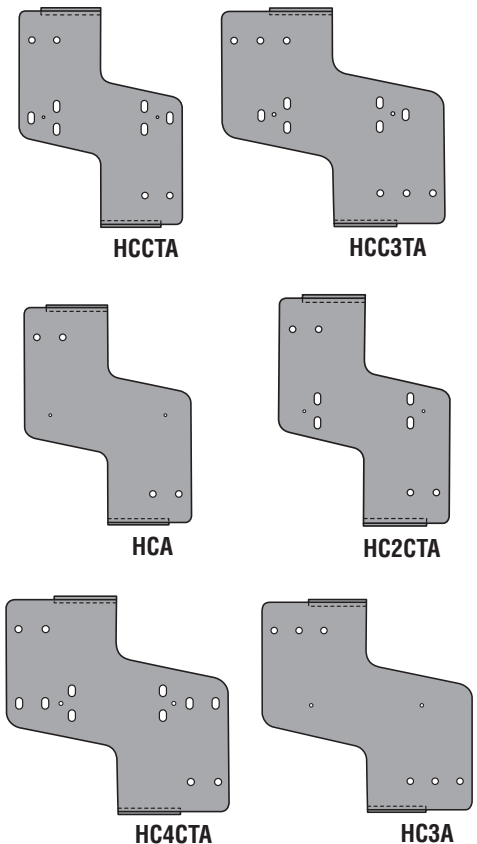

GENERAL CONNECTOR INSTALLATION

Engineered Wood & Structural Composite Lumber Connectors

TOP FLANGE HANGERS

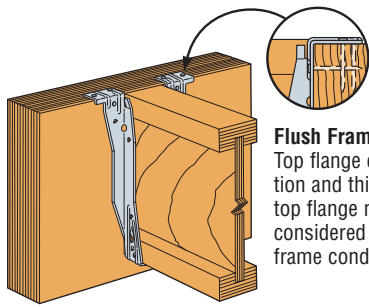

Flush Framing
Top flange configuration and thickness of top flange need to be considered for flush frame conditions.

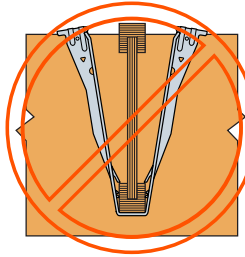

Hanger Over-Spread
If the hanger is over-spread, it can raise the I-joist above the header and may cause uneven surfaces and squeaky floors.

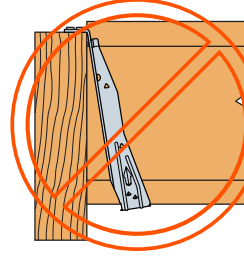

Hanger Not Plumb
A hanger "kicked-out" from the header can cause uneven surfaces and squeaky floors.

PREVENT ROTATION

Hangers provide some joist rotation resistance; however, additional lateral restraint may be required for deep joists.

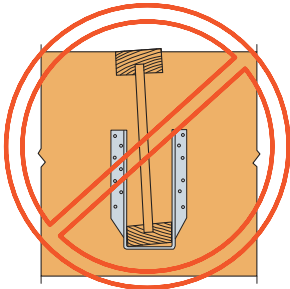

No Rotation Resistance
Lack of web stiffeners combined with short hanger allows unwanted rotation.

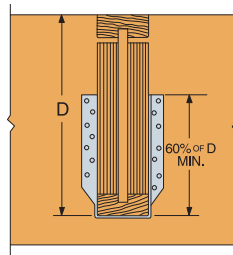

Rotation Prevented by Web Stiffeners
Hanger height should be at least 60% of the joist height.

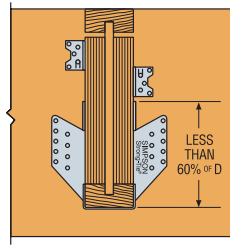

Rotation Prevented by Web Stiffeners
If hanger height is less than 60% of the joist height, add clips or blocking near the top.

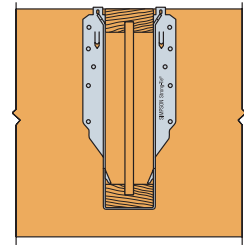

Rotation Prevented by Lateral Flange Support
Sides of hanger laterally support the top flange of the I-joist.
No web stiffeners required!

WOOD NAILERS

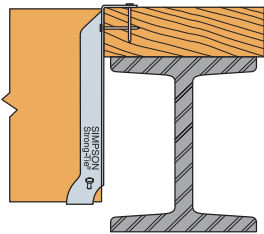

Correct Attachment

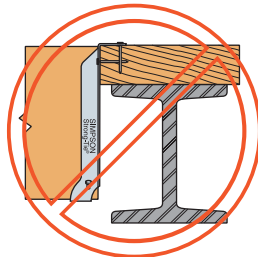

Nailer Too Wide
The loading may cause cross-grain bending. As a general rule, the maximum allowable overhang is 1/4", depending on nailer thickness.

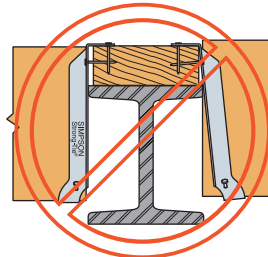

Nailer Too Narrow
Nailer should be full width.

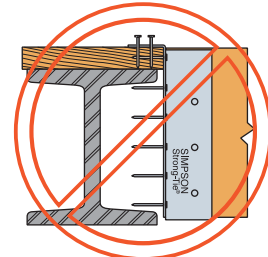

Nailer Too Thin
or the wrong hanger for the application.

TOE-NAILING

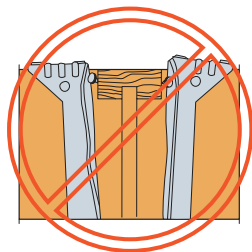

Toe nailing causes squeaks and improper hanger installations. Do not toe nail I-joists before installing top flange or face mount hangers.

POSITIVE ANGLE NAILING

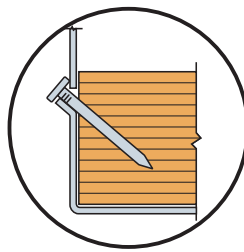

Correct Nailing
Approx. 45° angle

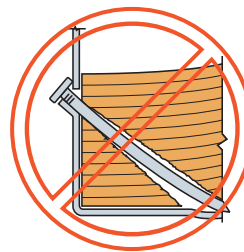

Nail too long

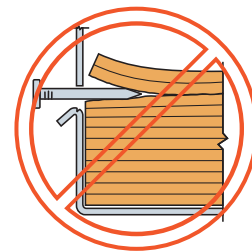

Nail at wrong angle

GENERAL CONNECTOR INSTALLATION

WOOD I-JOISTS

SLOPED JOISTS

For sloped joists up to ¼:12 there is no reduction. For slopes greater than ¼:12 see individual product pages or refer to technical bulletin T-SLOPEJST.

MULTIPLE JOISTS

Multiple joists should be adequately connected together to act as one unit.

FASTENERS

Use the correct nails. Wood may split if the nails are too large. Hanger nails into flanges should not exceed 10d common (0.148 dia.), no longer than 1½". Nails into web stiffeners should not exceed 16d commons (0.162 dia.).

ECCENTRICALLY-LOADED I-JOISTS

Supporting a top flange hanger may require bottom flange restraining straps, blocking or directly-applied ceiling systems to prevent rotation at the hanger location.

SKEWED JOISTS

Joists may be skewed up to 2½ degrees in a non-skewed hanger without any load reduction. Refer to individual hanger descriptions for information allowing any further skew applications.

I-JOIST AS A HEADER INSTALLATIONS

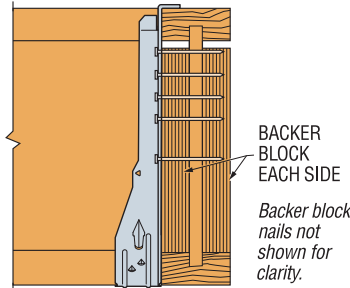

Face Mount Hanger

When face mount hangers are attached to I-joist headers, backer blocks must be installed to provide a nailing surface for the hanger nails. The backer blocks should be installed on both sides of the web and attached together with a minimum of 10-10d nails. The hanger nails should extend through the web. Contact the I-Joist manufacturer for additional design considerations.

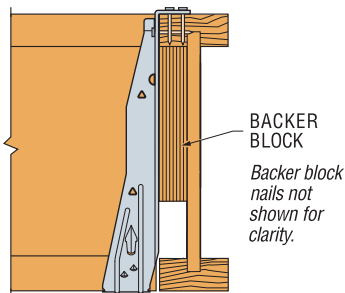

Top Flange Hanger

When top flange hangers are attached to I-joist headers, a backer block must be installed to prevent the top flange from rotating under load. The backer blocks should be installed with a minimum of 10-10d nails clinched. Check with the joist manufacturer for additional design considerations.

Engineered Wood & Structural Composite Lumber Connectors

CSC Ceiling Support Clip / FSS Furring Stabilizer Strap

Provides 1" separation between the furring channel and joist to allow for the use of Thermafiber® insulation and the attachment of the furring channel to all joists. Provides an efficient sound barrier, and a one hour U.L. listed fire rating.

- UL Listed. See Underwriters Laboratory, Inc. Design No. L530 for USG gypsum board and Weyerhaeuser/TJI® joists.
- Check ICC-ES reports for individual I-joist manufacturer approvals.

MATERIAL: 24 gauge (minimum)

FINISH: Galvanized

INSTALLATION:

- For CSC use 1-8dx1½ nail.
- For FSS use #8 self-tapping steel screw (not provided) into channel, twist 90°, bend upward and fasten to the side of joist bottom flange with screw or nail.

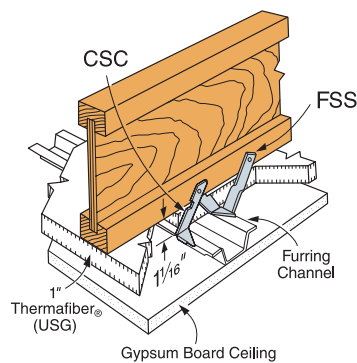

Typical CSC and FSS Installation

Thermafiber® and TJI® are registered trademarks of US Gypsum Company and Weyerhaeuser, respectively.

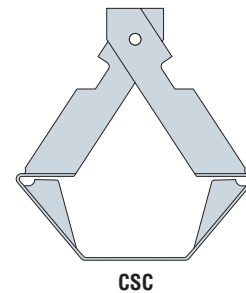

CSC

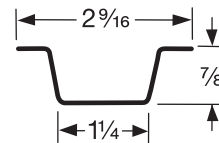

Furring Channel Detail

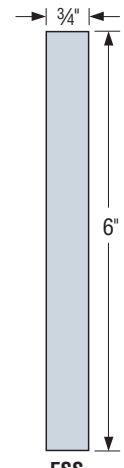

FSS

(See Installation Notes)

IUS/MIU I-Joist Hangers

Engineered Wood & Structural Composite Lumber Connectors



This product is preferable to similar connectors because of a) easier installation, b) higher loads, c) lower installed cost, or a combination of these features.

The IUS is a hybrid hanger that incorporates the advantages of the face mount and top mount hanger. Installation is fast with the Strong-Grip™ seat, easy-to-reach face nails and self-jigging locator tabs.

The MIU series hangers are designed for commercial and high load I-joist applications without requiring web stiffeners. The MIU features Positive Angle Nailing (PAN), which minimizes splitting of the flanges while permitting time-saving nailing from a better angle.

Refer to Joist Manufacturer's literature or appropriate Simpson Strong-Tie® Connector Selection Guide for actual joist sizes.

MATERIAL: See table on pages 112-116.

FINISH: Galvanized

UPLIFT LOADS: • Models have optional triangle joist nail holes for additional uplift. Properly attached web stiffeners are required.

- MIU—add four additional 10dx1½" joist nails for a total uplift load of 975 lbs.
- IUS—add web fillers and two 10dx1½" joist nails in the triangle holes for a total uplift of 365 lbs.

INSTALLATION: • Use all specified fasteners. Verify that the header can take the required fasteners specified in the table. See page 108 for more installation information.

- IUS—fasten hanger to header. Position I-joist into hanger and snap into place. No joist nailing required. Some IUS models have triangle and round header nail holes. To achieve Max. download, fill both round and triangle holes.
- IUS—Locator tabs are not structural. They may be bent back to adjust for hanger placement.
- IUS—for rimboard applications see technical bulletin T-RIMBDHGR.
- IUS— I-joists with web stiffeners or rectangular sections can be used with the installation of 2-10dx1½" nails into the optional triangle joist nails.
- IUS web stiffeners are not required with I-joists when the top flange is laterally supported by the sides of the hanger unless the manufacturer's no-web-stiffener reaction is exceeded.

OPTIONS:

These hangers cannot be modified. However, these models will normally accommodate a skew of up to 5°. For sloped joists up to ¼:12 there is no reduction, between ¼:12 and up to ½:12, tests show a 10% reduction in ultimate hanger strength. Local crushing of the bottom flange or excessive deflection may be limiting; check with joist manufacturer for specific limitations on bearing of this type.

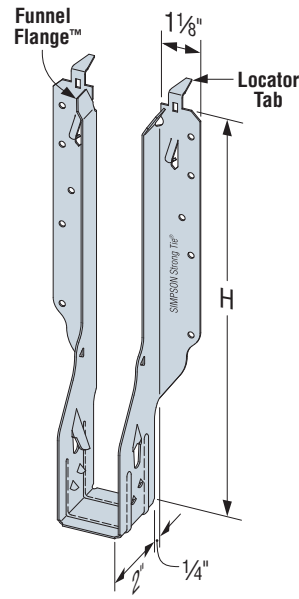

IUS
(Some IUS models have triangle holes in header flanges for Min/Max nailing)
U.S. Patent 6,523,321

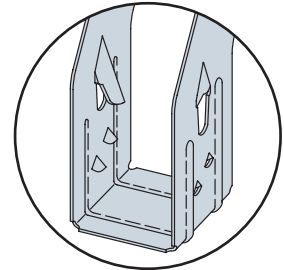

The Strong-Grip™ seat secures I-joists in position without joist nails

AVOID A MISINSTALLATION

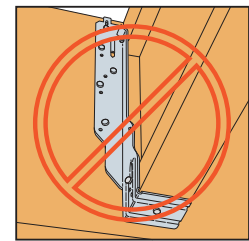

Do not make your own holes. Do not nail the bottom flange.

IUS INSTALLATION SEQUENCE

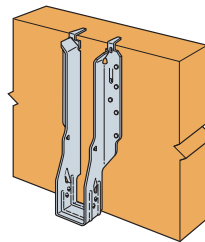

STEP 1
Attach the IUS to the header

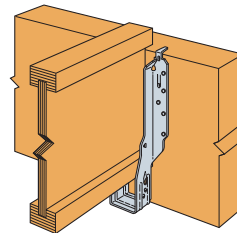

STEP 2
Slide the I-joist downward into the IUS until it rests above the large teardrop.

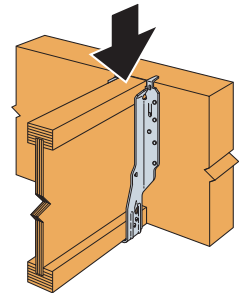

STEP 3
Firmly push or snap I-joist fully into the seat of the IUS.

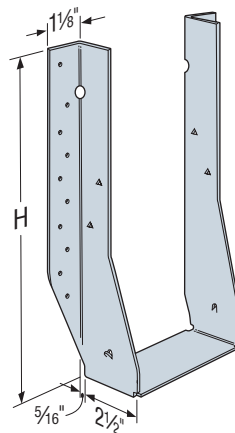

MIU

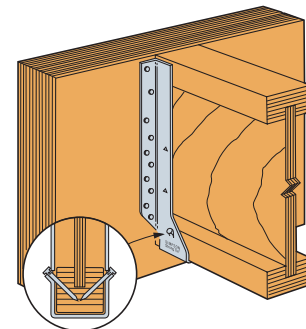

MIU with correct PAN installation

FACE MOUNT HANGERS U/HU/HUC/HUCQ I-Joist & Structural Composite Lumber Hangers

See Hanger tables on pages 112-116. See Hanger Options on pages 233-243 for hanger modifications, which may result in reduced loads.

U—The standard U hanger provides flexibility of joist to header installation. Versatile fastener selection with tested allowable loads.

HU/HUC—Most models have triangle and round holes. To achieve maximum loads, fill both round and triangle holes with common nails. These heavy-duty connectors are designed for schools and other structures requiring additional strength, longevity and safety factors.

HUCQ—Features concealed flanges so it can be installed close to the end of the supporting beam or on a post. They install with Simpson Strong-Tie® Strong-Drive® SDS Heavy-Duty Connector screws (supplied with the hanger) for high capacity and ease of installation.

MATERIAL: See tables on pages 112-116. **FINISH:** Galvanized

INSTALLATION: • Use all specified fasteners. See General Notes.

- HU/HUC—can be installed filling round holes only, or filling round and triangle holes for maximum values.
- HUCQ—When using structural composite lumber columns, the capacities shown in the tables are for fasteners applied to the wide face of the column.
- Web Stiffeners are required for all I-joists used with these hangers.
- For installation to masonry or concrete, see page 175.
- HU/HUC hangers can be welded to a steel member. Allowable loads are the lesser of the values in the Hanger tables on pages 112-116 or the weld capacity – refer to technical bulletin T-HUHUC-W.

OPTIONS: • HU is available with one flange concealed when the W dimension is less than 2 3/16" at 100% of the table load. Order HUC hanger.

- **Sloped, Skewed and Sloped/Skewed:**
 - For low-cost, code-listed 45° skews, see SUR/SUL and HSUR/HSUL. See also LSU/LSSU connectors.
 - U/HU may be skewed to a maximum of 45° and sloped to a maximum of 45°. Hangers 5 1/2" or less in width may be skewed to 67 1/2°. Hangers skewed 51°-67 1/2° require a square cut.
 - For all options, uplift loads are 0.75 of table loads.
 - For skewed hangers 3 9/16" and less in width, the allowable download is 100% of the table load. For skewed hangers over 3 9/16" in width the allowable download is 80% of the table load. For slope only, the allowable download is 100% of the table load.
 - For combined slopes and skews, the maximum allowable download is 0.80 of the table load.
- For sloped and skewed hangers, the flange on the acute side flange can be concealed at 0.80 of the table load. Contact Simpson Strong-Tie for skew limitations.
- See Hanger Options on pages 233-243 for additional information.
- See also HUS series.
- HUCQ cannot be modified.

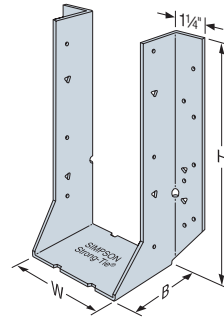

HU410

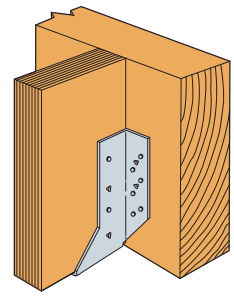

Typical HU7 Installation

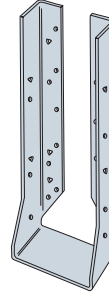

**HUC412
Concealed
Flanges**

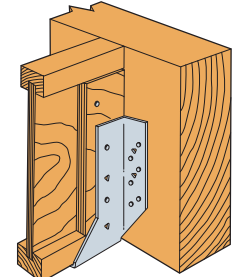

Typical HU7 Installation

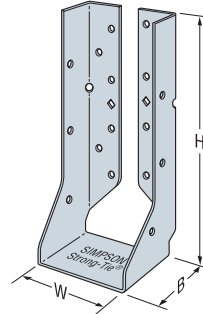

HUCQ

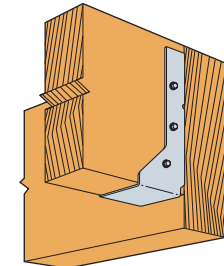

Typical HUCQ Installed on End of a Beam

Model configurations may differ from those shown. Some HU models do not have triangle holes. Contact Simpson Strong-Tie for details.

Engineered Wood & Structural Composite Lumber Connectors

FACE MOUNT HANGERS HUS/HHUS/HGUS Double Shear SCL Hangers

See Hanger tables on pages 122-126. See Hanger Options on pages 233-243 for hanger modifications, which may result in reduced loads.

These hangers are designed for applications where higher loads are needed (also see HUC and HUCQ).

All hangers in this series have double shear nailing. This patented innovation distributes the load through two points on each joist nail for greater strength. It also allows the use of fewer nails, faster installation, and the use of common nails for all connections. (Do not bend or remove tabs)

MATERIAL: See tables on pages 122-126.

FINISH: Galvanized. Some products available in stainless steel or ZMAX®; see Corrosion Information, pages 13-15.

INSTALLATION • Use all specified fasteners. See General Notes.

- Do not use double shear hangers with I-joists.
- Nails must be driven at an angle through the joist or truss into the header to achieve the table loads.
- Not designed for welded or nailer applications.
- 16d sinkers (0.148" dia. x 3 1/4" long) may be used where 10d commons are specified with no reduction in load. Where 16d commons are specified, 10d commons or 16d sinkers (0.148" dia. x 3 1/4" long) may be used at 0.85 of the table load.
- With 3x carrying members, use 16d x 2 1/2" (Simpson Strong-Tie® N16) nails into the header and 16d commons into the joist with no load reduction. With 2x carrying members, use 10d x 1 1/2" nails into the header and 10d commons into the joist, and reduce the load to 0.64 of the table value.

OPTIONS: • HUS hangers available with the header flanges turned in for 3 1/2" wide joist only, with no load reduction. See HUSC Concealed Flange illustration.

- Concealed flanges are not available for HGUS, HUS1.81/10 and HHUS.
- See Hanger Options, pages 233-243, for sloped and/or skewed HHUS and HGUS models.
- Other sizes available; contact Simpson Strong-Tie for details.

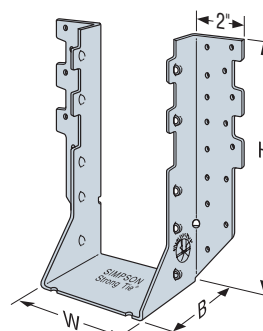

HHUS410

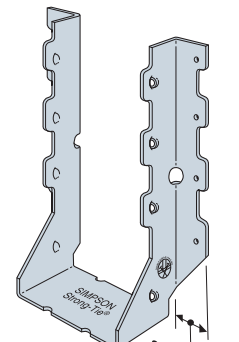

HUS410

2" for 2x's
1 1/8" for 4x's

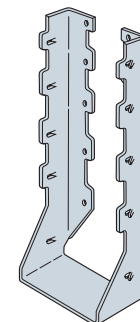

**HUSC
Concealed
Flanges**
(not available for HHUS, HGUS and HUS1.81/10)

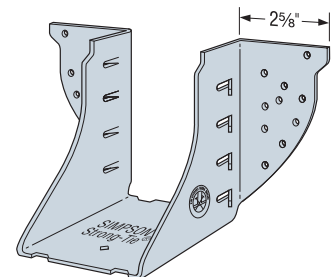

HGUS46

FACE MOUNT HANGERS – I-JOISTS

Engineered Wood & Structural Composite Lumber Connectors

Actual Joist Size	Model No. ³	Web Stiff Req'd	Ga	Dimensions				Fasteners ⁶		Allowable Loads ⁵							Code Ref.
				W	H	B	Min/Max ²	Face	Joist	DF/SP Species Header				SPF/HF Species Header			
										Uplift (160)	Floor (100)	Snow (115)	Roof (125)	Floor (100)	Snow (115)	Roof (125)	
1½ x 9½	U210	✓	16	1⅞	7⅞	2	—	6-10d	6-10dx1½	1110	1215	1375	1485	1045	1185	1275	19, F8, L12
	MIU1.56/9	—	16	1⅞	8⅞	2½	—	16-16d	2-10dx1½	230	2305	2615	2820	1980	2245	2425	
1½ x 11¼ - 11⅞	U210	✓	16	1⅞	7⅞	2	—	6-10d	6-10dx1½	1110	1215	1375	1485	1045	1185	1275	
	MIU1.56/11	—	16	1⅞	11⅞	2½	—	20-16d	2-10dx1½	230	2880	3060	3080	2475	2695	2695	
1¾ x 9½	IUS1.81/9.5	—	18	1⅞	9½	2	—	8-10d	—	75	950	1080	1165	815	925	1000	
1¾ x 9½ - 9½	MIU1.81/9	—	16	1⅞	8⅞	2½	—	16-16d	2-10dx1½	230	2305	2615	2820	1980	2245	2425	
	IUS1.81/11.88	—	18	1⅞	11⅞	2	—	10-10d	—	75	1185	1345	1455	1020	1160	1250	
1¾ x 11⅞	MIU1.81/11	—	16	1⅞	11⅞	2½	—	20-16d	2-10dx1½	230	2880	3135	3135	2475	2695	2695	
	IUS1.81/14	—	18	1⅞	14	2	Min	12-10d	—	75	1420	1615	1745	1220	1390	1500	
1¾ x 14	MIU1.81/14	—	16	1⅞	14	2	Max	14-10d	—	75	1660	1885	1980	1425	1620	1705	
	IUS1.81/16	—	18	1⅞	16	2	Min	14-10d	—	75	1660	1885	1980	1425	1620	1705	
1¾ x 16	MIU1.81/16	—	16	1⅞	16	2	Max	16-10d	—	75	1895	1980	1980	1630	1705	1705	
	IUS1.81/18	—	18	1⅞	18	2	Min	14-10d	—	75	1660	1885	1980	1425	1620	1705	
1¾ x 18 - 20	MIU1.81/18	—	16	1⅞	15⅞	2½	—	24-16d	2-10dx1½	230	3455	3530	3550	2970	3370	3480	
	IUS2.06/11.88	—	18	1⅞	17⅞	2½	—	26-16d	2-10dx1½	230	3500	3530	3550	3220	3465	3480	
2 x 9½	IUS2.06/9.5	—	18	2⅞	9½	2	—	8-10d	—	75	950	1080	1165	815	925	1000	
	IUS2.06/11.88	—	18	2⅞	11⅞	2	—	10-10d	—	75	1185	1345	1455	1020	1160	1250	
2 x 14	IUS2.06/14	—	18	2⅞	14	2	Min	12-10d	—	75	1420	1615	1745	1220	1390	1500	
	IUS2.06/16	—	18	2⅞	14	2	Max	14-10d	—	75	1660	1885	1980	1425	1620	1705	
2 x 16	IUS2.06/16	—	18	2⅞	16	2	Min	14-10d	—	75	1660	1885	1980	1425	1620	1705	
	IUS2.06/16	—	18	2⅞	16	2	Max	16-10d	—	75	1895	1980	1980	1630	1705	1705	
2⅞ x 9½	IUS2.06/9.5	—	18	2⅞	9½	2	—	8-10d	—	75	950	1080	1165	815	925	1000	
	HU2.1/9	✓	14	2⅞	9	2½	—	14-16d	6-10dx1½	915	2085	2350	2530	1795	2025	2180	
2⅞ x 11⅞	IUS2.06/11.88	—	18	2⅞	11⅞	2	—	10-10d	—	75	1185	1345	1455	1020	1160	1250	
	MIU2.1/11	—	16	2⅞	11⅞	2½	—	20-16d	2-10dx1½	230	2880	3135	3135	2475	2695	2695	
	HU2.1/11	✓	14	2⅞	11	2½	—	16-16d	6-10dx1½	915	2380	2685	2890	2050	2315	2490	
2⅞ x 14	IUS2.06/14	—	18	2⅞	14	2	—	12-10d	—	75	1420	1615	1745	1220	1390	1500	
2⅞ x 16	IUS2.06/16	—	18	2⅞	16	2	—	14-10d	—	75	1660	1885	1980	1425	1620	1705	
2¼ x 9½ to 20	2¼" wide joists use the same hangers as 2⅞" wide joists with the following load adjustments to the table loads: IUS download is the lesser of the table load or 1400 lbs. IUS uplift is 55 lbs. MIU and U downloads are the lesser of the table load or 2140 lbs.																
2⅞ x 9½	IUS2.37/9.5	—	18	2⅞	9½	2	—	8-10d	—	75	950	1080	1165	815	925	1000	
	MIU2.37/9	—	16	2⅞	9	2½	—	16-16d	2-10dx1½	230	2305	2615	2820	1980	2245	2425	
	U3510/14	✓	16	2⅞	9	2	—	14-16d	6-10dx1½	1110	2015	2285	2465	1735	1965	2120	
	HU359/HUC359	✓	14	2⅞	8⅞	2½	Min	14-16d	6-10dx1½	915	2085	2350	2530	1795	2025	2180	
✓		14	2⅞	8⅞	2½	Max	18-16d	10-10dx1½	1895	2680	3020	3250	2305	2605	2800		
2⅞ x 11⅞	IUS2.37/11.88	—	18	2⅞	11⅞	2	—	10-10d	—	75	1185	1345	1455	1020	1160	1250	
	MIU2.37/11	—	16	2⅞	11⅞	2½	—	20-16d	2-10dx1½	230	2880	3135	3135	2475	2695	2695	
	U3516/20	✓	16	2⅞	10⅞	2	—	16-16d	6-10dx1½	1110	2305	2615	2820	1980	2245	2425	
	HU3511/HUC3511	✓	14	2⅞	11⅞	2½	Min	16-16d	6-10dx1½	915	2380	2685	2890	2050	2315	2490	
✓		14	2⅞	11⅞	2½	Max	22-16d	10-10dx1½	1895	3275	3695	3970	2820	3180	3425		
2⅞ x 14	IUS2.37/14	—	18	2⅞	14	2	Min	12-10d	—	75	1420	1615	1745	1220	1390	1500	
	MIU2.37/14	—	16	2⅞	13½	2½	—	22-16d	2-10dx1½	230	3170	3595	3875	2725	3090	3335	
	HU3514/HUC3514	✓	14	2⅞	13½	2½	Min	18-16d	8-10dx1½	1515	2680	3020	3250	2305	2605	2800	
		✓	14	2⅞	13½	2½	Max	24-16d	12-10dx1½	2015	3570	4030	4335	3075	3470	3735	
2⅞ x 16	IUS2.37/16	—	18	2⅞	16	2	Min	14-10d	—	75	1660	1885	1980	1425	1620	1705	
	MIU2.37/16	—	16	2⅞	15½	2½	—	24-16d	2-10dx1½	230	3455	3920	4045	2970	3370	3480	
	HU3516/22/HUC3516/22	✓	14	2⅞	14¼	2½	—	20-16d	8-10dx1½	1515	2975	3360	3610	2565	2895	3110	

- Uplift loads based on DF/SP lumber and have been increased for wind or earthquake loading with no further increase allowed. Reduce where other loads govern. For SPF/HF use 0.86 x DF/SP uplift load.
- MIN nailing quantity and load values—fill all round holes; MAX nailing quantity and load values—fill all round and triangle holes.
- Hangers sorted in order of recommended selection for best overall performance and installation value.

- Web stiffeners are required where noted in the table or when the joist top flange isn't supported laterally by the hanger or when supporting double I-joists with flanges less than 1⅞" thick.
- Allowable downloads are based on a joist bearing capacity of 750 psi.
- NAILS:** 16d = 0.162" dia. x 3½" long, 10d = 0.148" dia. x 3" long, 10dx1½ = 0.148" dia. x 1½" long. See pages 22-23 for other nail sizes and information.

CODES: See page 12 for Code Reference Key Chart.

FACE MOUNT HANGERS – I-JOISTS

These products are available with additional corrosion protection. Additional products on this page may also be available with this option, check with Simpson Strong-Tie for details.

Actual Joist Size	Model No. ³	Web Stiff Req'd	Ga	Dimensions			Min/Max ²	Fasteners ⁶		Allowable Loads ⁵						Code Ref.		
				W	H	B		Face	Joist	DF/SP Species Header			SPF/HF Species Header					
										Uplift (160)	Floor (100)	Snow (115)	Roof (125)	Floor (100)	Snow (115)		Roof (125)	
2 5/16 x 18	MIU2.37/18	—	16	2 5/16	17 1/2	2 1/2	—	26-16d	2-10dx1 1/2	230	3745	4045	4045	3220	3480	3480	I9, F8, L12	
	HU3524/30	✓	14	2 5/16	18	2 1/2	Min	18-16d	8-10dx1 1/2	1515	2680	3020	3250	2305	2605	2800		
		✓	14	2 5/16	18	2 1/2	Max	24-16d	14-10dx1 1/2	2015	3570	4030	4335	3075	3470	3735		
2 5/16 x 20	MIU2.37/20	—	16	2 5/16	19 1/2	2 1/2	—	28-16d	2-10dx1 1/2	230	4030	4060	4060	3465	3495	3495		
2 5/16 x 22 - 30	MIU2.37/20	✓	16	2 5/16	19 1/2	2 1/2	—	28-16d	2-10dx1 1/2	230	4030	4060	4060	3465	3495	3495		
	HU3524/30		14	2 5/16	18	2 1/2	Min	18-16d	8-10dx1 1/2	1515	2680	3020	3250	2305	2605	2800		
			✓	14	2 5/16	18	2 1/2	Max	24-16d	14-10dx1 1/2	2015	3570	4030	4335	3075	3470	3735	
2 5/16 x 9 1/2 to 16	2 5/16" wide joists use the same hangers as 2 1/2" wide joists with the following load adjustments to the table loads: IUS download is same as table but not to exceed 1400 lbs. IUS uplift is 55 lbs. MIU download is same as table but not to exceed 2140 lbs.																	
2 1/2 x 9 1/4	IUS2.56/9.25	—	18	2 5/16	9 1/4	2	—	8-10d	—	75	950	1080	1165	815	925	1000	I9	
2 1/2 x 9 1/2	IUS2.56/9.5	—	18	2 5/16	9 1/2	2	—	8-10d	—	75	950	1080	1165	815	925	1000	I9, F8, L12	
2 1/2 - 2 5/16 x 9 1/4 - 9 1/2	MIU2.56/9	—	16	2 5/16	8 3/16	2 1/2	—	16-16d	2-10dx1 1/2	230	2305	2615	2820	1980	2245	2425	I9, F8, L12, L17	
	HU310/HUC310	✓	14	2 5/16	8 7/8	2 1/2	—	14-16d	6-10dx1 1/2	915	2085	2350	2530	1795	2025	2180		
2 1/2 - 2 5/16 x 11 1/8	IUS2.56/11.88	—	18	2 5/16	11 7/8	2	—	10-10d	—	75	1185	1345	1455	1020	1160	1250	I9, F8, L12	
2 1/2 x 11 1/4 - 11 1/2	MIU2.56/11	—	16	2 5/16	11 1/16	2 1/2	—	20-16d	2-10dx1 1/2	230	2880	3135	3135	2475	2695	2695	I9, F8, L12, L17	
	HU312/HUC312	✓	14	2 5/16	10 5/8	2 1/2	—	16-16d	6-10dx1 1/2	915	2380	2685	2890	2050	2315	2490		
2 1/2 x 14	IUS2.56/14	—	18	2 5/16	14	2	Min	12-10d	—	75	1420	1615	1745	1220	1390	1500	I9, F8, L12	
	MIU2.56/14	—	16	2 5/16	13 7/16	2 1/2	—	22-16d	2-10dx1 1/2	230	3170	3595	3875	2725	3090	3335		
		✓	14	2 5/16	12 3/4	2 1/2	—	18-16d	8-10dx1 1/2	1515	2680	3020	3250	2305	2605	2800		
2 1/2 x 16	IUS2.56/16	—	18	2 5/16	16	2	Min	14-10d	—	75	1660	1885	1980	1425	1620	1705		I9, F8, L12
	MIU2.56/16	—	16	2 5/16	15 1/16	2 1/2	—	24-16d	2-10dx1 1/2	230	3455	3920	4045	2970	3370	3480		
		✓	14	2 5/16	14 1/8	2 1/2	—	20-16d	8-10dx1 1/2	1515	2975	3360	3610	2565	2895	3110		
2 1/2 x 18	MIU2.56/18	—	16	2 5/16	17 1/16	2 1/2	—	26-16d	2-10dx1 1/2	230	3745	4045	4045	3220	3480	3480		
2 1/2 - 2 5/16 x 20	MIU2.56/20	—	16	2 5/16	19 1/16	2 1/2	—	28-16d	2-10dx1 1/2	230	4030	4060	4060	3465	3495	3495		
2 1/2 x 22 - 26	MIU2.56/20	✓	16	2 5/16	19 1/16	2 1/2	—	28-16d	2-10dx1 1/2	230	4030	4060	4060	3465	3495	3495		
2 5/16 x 9 1/4 to 26	2 5/16" wide joists use the same hangers as 2 1/2" wide joists.																	
3 x 9 1/4 - 9 1/2	MIU3.12/9	—	16	3 1/8	9 1/16	2 1/2	—	16-16d	2-10dx1 1/2	230	2305	2615	2820	1980	2245	2425	I9, F8, L12	
	HU210-2/HUC210-2	✓	14	3 1/8	8 3/16	2 1/2	Min	14-16d	6-10d	1135	2085	2350	2530	1795	2025	2180		
		✓	14	3 1/8	8 3/16	2 1/2	Max	18-16d	10-10d	1895	2680	3020	3250	2305	2605	2800		
3 x 11 1/4 - 11 1/2	MIU3.12/11	—	16	3 1/8	11 1/16	2 1/2	—	20-16d	2-10dx1 1/2	230	2880	3135	3135	2475	2695	2695	I9, F8, L12	
	HU212-2/HUC212-2	✓	14	3 1/8	10 9/16	2 1/2	Min	16-16d	6-10d	1135	2380	2685	2890	2050	2315	2490		
		✓	14	3 1/8	10 9/16	2 1/2	Max	22-16d	10-10d	1895	3275	3695	3970	2820	3180	3425		
3 x 14 - 20	MIU3.12/11	✓	16	3 1/8	11 1/8	2 1/2	—	20-16d	2-10dx1 1/2	230	2880	3135	3135	2475	2695	2695	I9, F8, L12	
	HU212-2/HUC212-2		14	3 1/8	10 9/16	2 1/2	Min	16-16d	6-10d	1135	2380	2685	2890	2050	2315	2490		
			✓	14	3 1/8	10 9/16	2 1/2	Max	22-16d	10-10d	1895	3275	3695	3970	2820	3180		3425
3 1/2 x 9 1/2	IUS3.56/9.5	—	18	3 3/8	9 1/2	2	—	10-10d	—	75	1185	1345	1455	1020	1160	1250		
3 1/2 x 9 1/4 - 9 1/2	MIU3.56/9	—	16	3 3/8	8 3/16	2 1/2	—	16-16d	2-10dx1 1/2	210	2305	2615	2820	1980	2245	2425		
3 1/2 x 11 1/8	IUS3.56/11.88	—	18	3 3/8	11 1/8	2	—	12-10d	—	75	1420	1615	1725	1220	1390	1485		
3 1/2 x 11 1/4 - 11 1/2	MIU3.56/11	—	16	3 3/8	11 1/8	2 1/2	—	20-16d	2-10dx1 1/2	210	2880	3135	3135	2475	2695	2695		
3 1/2 x 14	IUS3.56/14	—	18	3 3/8	14	2	Min	12-10d	—	75	1420	1615	1725	1220	1390	1485	I9, F8, L12	
	MIU3.56/14		16	3 3/8	14	2	Max	14-10d	—	75	1660	1725	1725	1425	1485	1485		
			✓	16	3 3/8	13 3/16	2 1/2	—	22-16d	2-10dx1 1/2	210	3170	3595	3875	2725	3090		3335
3 1/2 x 16	IUS3.56/16	—	18	3 3/8	16	2	Min	14-10d	—	75	1660	1725	1725	1425	1485	1485		
	MIU3.56/16		16	3 3/8	16	2	Max	16-10d	—	75	1725	1725	1725	1485	1485	1485		
3 1/2 x 18	MIU3.56/18	—	16	3 3/8	15 1/16	2 1/2	—	24-16d	2-10dx1 1/2	210	3455	3920	4045	2970	3370	3480		
3 1/2 x 20	MIU3.56/20	—	16	3 3/8	17 1/16	2 1/2	—	26-16d	2-10dx1 1/2	210	3745	4045	4045	3220	3480	3480		
3 1/2 x 22 - 30	MIU3.56/20	✓	16	3 3/8	19 1/16	2 1/2	—	28-16d	2-10dx1 1/2	210	4030	4060	4060	3465	3495	3495		

- Uplift loads based on DF/SP lumber and have been increased for wind or earthquake loading with no further increase allowed. Reduce where other loads govern. For SPF/HF use 0.86 x DF/SP uplift load.
- MIN nailing quantity and load values—fill all round holes; MAX nailing quantity and load values—fill all round and triangle holes.
- Hangers sorted in order of recommended selection for best overall performance and installation value.

- Web stiffeners are required where noted in the table or when the joist top flange isn't supported laterally by the hanger or when supporting double I-joists with flanges less than 1 5/8" thick.
- Allowable downloads are based on a joist bearing capacity of 750 psi.
- NAILS:** 16d = 0.162" dia. x 3 1/2" long, 10d = 0.148" dia. x 3" long, 10dx1 1/2 = 0.148" dia. x 1 1/2" long. See pages 22-23 for other nail sizes and information.

CODES: See page 12 for Code Reference Key Chart.

FACE MOUNT HANGERS – I-JOISTS

Engineered Wood & Structural Composite Lumber Connectors

Actual Joist Size	Model No. ³	Web Stiff Req'd	Ga	Dimensions				Fasteners ⁵		Allowable Loads ⁵						Code Ref.	
				W	H	B	Min/Max ²	Face	Joist	DF/SP Species Header				SPF/HF Species Header			
										Uplift (160)	Floor (100)	Snow (115)	Roof (125)	Floor (100)	Snow (115)		Roof (125)
4 x 9½	MIU4.12/9	—	16	4⅜	9⅛	2½	—	16-16d	2-10dx1½	210	2305	2615	2820	1980	2245	2425	I9, F8, L12
	HU4.12/9/HUC4.12/9	✓	14	4⅜	8⅝	2½	Min	14-16d	6-10d	1135	2085	2350	2530	1795	2025	2180	
4 x 11⅝ - 16	MIU4.12/11	—	16	4⅜	11⅛	2½	—	20-16d	2-10dx1½	210	2880	3135	3135	2475	2695	2695	
	HU4.12/11/HUC4.12/11	✓	14	4⅜	10⅞	2½	Min	16-16d	6-10d	1135	2380	2685	2890	2050	2315	2490	
4 x 14	MIU4.12/14	—	16	4⅜	13⅞	2½	—	22-16d	2-10dx1½	210	3170	3595	3875	2725	3090	3335	
	MIU4.12/16	—	16	4⅜	15⅞	2½	—	24-16d	2-10dx1½	210	3455	3920	4045	2970	3370	3480	
4⅝ x 9½	MIU4.28/9	—	16	4⅝	9	2½	—	16-16d	2-10dx1½	210	2305	2615	2820	1980	2245	2425	
	HU4.28/9/HUC4.28/9	✓	14	4⅝	9	2½	—	18-16d	8-10d	1515	2680	3020	3250	2305	2605	2800	
4⅝ x 11⅝	MIU4.28/11	—	16	4⅝	11⅝	2½	—	20-16d	2-10dx1½	210	2880	3135	3135	2475	2695	2695	
	HU4.28/11/HUC4.28/11	✓	14	4⅝	11	2½	—	22-16d	8-10d	1515	3275	3695	3970	2820	3180	3425	
4⅝ x 14	MIU4.28/14	—	16	4⅝	13½	2½	—	22-16d	2-10dx1½	210	3170	3595	3875	2725	3090	3335	
4⅝ x 16	MIU4.28/16	—	16	4⅝	15½	2½	—	24-16d	2-10dx1½	210	3455	3920	4045	2970	3370	3480	
4½ x 9½ to 20	4½" wide joists use the same hangers as 4⅝" wide joists with the following loads adjustments: MIU and U downloads are the lesser of the table load or 2140 lbs.																
4⅝ x 9¼ - 9½	MIU4.75/9	—	16	4¾	9⅛	2½	—	16-16d	2-10dx1½	210	2305	2615	2820	1980	2245	2425	I9, F8, L12
	U3510-2	✓	16	4¾	8¾	2	—	14-16d	6-10d	1110	2015	2285	2465	1735	1965	2120	
4⅝ x 11¼ - 11⅝	MIU4.75/11	—	16	4¾	11⅛	2½	—	20-16d	2-10dx1½	210	2880	3135	3135	2475	2695	2695	I9, F8, L12
	U3512-2	✓	16	4¾	11¼	2	—	16-16d	6-10d	1110	2305	2615	2820	1980	2245	2425	
4⅝ x 14	MIU4.75/14	—	16	4¾	13½	2½	—	22-16d	2-10dx1½	210	3170	3595	3875	2725	3090	3335	I9
	HU3514-2/HUC3514-2	✓	14	4¾	13¼	2½	—	18-16d	8-10d	1515	2680	3020	3250	2305	2605	2800	
4⅝ x 16	MIU4.75/16	—	16	4¾	15½	2½	—	24-16d	2-10dx1½	210	3455	3920	4045	2970	3370	3480	I9, F8, L12
	HU3516-2/HUC3516-2	✓	14	4¾	15¼	2½	Min	20-16d	8-10d	1515	2975	3360	3610	2565	2895	3110	
4⅝ x 18	MIU4.75/18	—	16	4¾	17½	2½	—	26-16d	2-10dx1½	210	3745	4045	4045	3220	3480	3480	I9, F8, L12
	MIU4.75/20	—	16	4¾	19½	2½	—	28-16d	2-10dx1½	210	4030	4060	4060	3465	3495	3495	
4⅝ x 20	MIU4.75/20	—	16	4¾	19¼	2½	Min	20-16d	8-10d	1515	2975	3360	3610	2565	2895	3110	I9, F8, L12
	HU3520-2	✓	14	4¾	19¼	2½	Max	26-16d	12-10d	2015	3870	4365	4695	3330	3760	4045	
4⅝ x 22 - 30	MIU4.75/20	—	16	4¾	19½	2½	—	28-16d	2-10dx1½	210	4030	4060	4060	3465	3495	3495	I9, F8, L12
	HU3520-2	✓	14	4¾	19¼	2½	Min	20-16d	8-10d	1515	2975	3360	3610	2565	2895	3110	
5 x 9¼ - 9½	MIU5.12/9	—	16	5⅝	8⅞	2½	—	16-16d	2-10dx1½	210	2305	2615	2820	1980	2245	2425	I9, F8, L12, L17
	HU310-2/HUC310-2	✓	14	5⅝	8⅞	2½	—	14-16d	6-10d	1135	2085	2350	2530	1795	2025	2180	
5 x 11¼ - 11⅝	MIU5.12/11	—	16	5⅝	11⅛	2½	—	20-16d	2-10dx1½	210	2880	3135	3135	2475	2695	2695	I9, F8, L12
	HU312-2/HUC312-2	✓	14	5⅝	10⅞	2½	—	16-16d	6-10d	1135	2380	2685	2890	2050	2315	2490	
5 x 14	MIU5.12/14	—	16	5⅝	13⅞	2½	—	22-16d	2-10dx1½	210	3170	3595	3875	2725	3090	3335	I9, F8, L12, L17
	HU314-2/HUC314-2	✓	14	5⅝	12⅞	2½	—	18-16d	8-10d	1515	2680	3020	3250	2305	2605	2800	
5 x 16	MIU5.12/16	—	16	5⅝	15⅞	2½	—	24-16d	2-10dx1½	210	3455	3920	4045	2970	3370	3480	I9, F8, L12
5 x 18	MIU5.12/18	—	16	5⅝	17⅞	2½	—	26-16d	2-10dx1½	210	3745	4045	4045	3220	3480	3480	
5 x 20	MIU5.12/20	—	16	5⅝	19⅞	2½	—	28-16d	2-10dx1½	210	4030	4060	4060	3465	3495	3495	
5 x 22 - 30	MIU5.12/20	✓	16	5⅝	19⅞	2½	—	28-16d	2-10dx1½	210	4030	4060	4060	3465	3495	3495	
7 x 9¼ - 9½	HU410-2/HUC410-2	✓	14	7⅞	9⅞	2½	Min	14-16d	6-16d	1345	2085	2350	2530	1795	2025	2180	
				7⅞	9⅞	2½	Max	18-16d	8-16d	1795	2680	3020	3250	2305	2605	2800	
7 x 11¼ - 11⅝	HU412-2/HUC412-2	✓	14	7⅞	11⅞	2½	Min	16-16d	6-16d	1345	2380	2685	2890	2050	2315	2490	
				7⅞	11⅞	2½	Max	22-16d	8-16d	1795	3275	3695	3970	2820	3180	3425	
7 x 14	HU414-2/HUC414-2	✓	14	7⅞	13⅞	2½	Min	20-16d	8-16d	1795	2975	3360	3610	2565	2895	3110	
				7⅞	13⅞	2½	Max	26-16d	12-16d	2695	3870	4365	4695	3330	3760	4045	

1. Uplift loads based on DF/SP lumber and have been increased for wind or earthquake loading with no further increase allowed. Reduce where other loads govern. For SPF/HF use 0.86 x DF/SP uplift load.
 2. MIN nailing quantity and load values—fill all round holes;
 MAX nailing quantity and load values—fill all round and triangle holes.
 3. Hangers sorted in order of recommended selection for best overall performance and installation value.

4. Web stiffeners are required where noted in the table or when the joist top flange isn't supported laterally by the hanger or when supporting double I-joists with flanges less than 1⅝" thick.
 5. Allowable downloads are based on a joist bearing capacity of 750 psi.
 6. **NAIS:** 16d = 0.162" dia. x 3½" long, 10d = 0.148" dia. x 3" long, 10dx1½ = 0.148" dia. x 1½" long. See pages 22-23 for other nail sizes and information.

CODES: See page 12 for Code Reference Key Chart.

FACE MOUNT HANGERS – STRUCTURAL COMPOSITE LUMBER

These products are available with additional corrosion protection. Additional products on this page may also be available with this option, check with Simpson Strong-Tie for details.

CODES: See page 12 for Code Reference Key Chart.

Actual Joist Size	Model No. ³	Ga	Dimensions				Fasteners ⁵		Allowable Loads ⁴						Code Ref.	
			W	H	B	Min/Max ²	Face	Joist	DF/SP Species Header				SPF/HF Species Header			
									Uplift (160)	Floor (100)	Snow (115)	Roof (125)	Floor (100)	Snow (115)		Roof (125)
1 3/4 x 5 1/2	HU1.81/5	14	1 13/16	5 3/8	2 1/2	Min	12-16d	4-10dx1 1/2	610	1785	2015	2165	1540	1735	1865	I9, L12, F8
			1 13/16	5 3/8	2 1/2	Max	16-16d	6-10dx1 1/2	915	2380	2685	2890	2050	2315	2490	
1 3/4 x 7 1/4	HU7	14	1 13/16	6 11/16	2 1/2	Min	12-16d	4-10dx1 1/2	610	1785	2015	2165	1540	1735	1865	I9, F8, L12
			1 13/16	6 11/16	2 1/2	Max	16-16d	8-10dx1 1/2	1515	2380	2685	2890	2050	2315	2490	
1 3/4 x 9 1/2	HUS1.81/10	16	1 13/16	8 7/8	3	—	30-16d	10-16d	3000	5135	5295	5400	4705	5105	5195	I9, F23
	HU9	14	1 13/16	9 5/16	2 1/2	Min	18-16d	6-10dx1 1/2	915	2680	3020	3250	2305	2605	2800	I9, F8, L12
			1 13/16	9 5/16	2 1/2	Max	24-16d	10-10dx1 1/2	1895	3570	4030	4335	3075	3470	3735	
HUCQ1.81/9-SDS	14	1 13/16	9	3	—	8-SDS 1/4"x1 3/4"	4-SDS 1/4"x1 3/4"	1505	2000	2300	2500	1440	1655	1800	I9, F23, L12	
1 3/4 x 11 1/4 - 11 3/8	HUS1.81/10	16	1 13/16	8 7/8	3	—	30-16d	10-16d	3000	5135	5295	5400	4705	5105	5195	I9, F23
	HU11	14	1 13/16	11 1/16	2 1/2	Min	22-16d	6-10dx1 1/2	915	3275	3695	3970	2820	3180	3425	I9, L12, F8
			1 13/16	11 1/16	2 1/2	Max	30-16d	10-10dx1 1/2	1895	4465	4705	4810	3845	4340	4600	
HUCQ1.81/11-SDS	14	1 13/16	11	3	—	10-SDS 1/4"x1 3/4"	4-SDS 1/4"x1 3/4"	1505	2500	2875	3125	1800	2070	2250	I9, F23, L12	
1 3/4 x 14	HUS1.81/10	16	1 13/16	8 7/8	3	—	30-16d	10-16d	3000	5135	5295	5400	4705	5105	5195	I9, F23
	U14		1 13/16	10 1/4	2	—	14-16d	6-10dx1 1/2	1110	2015	2285	2465	1735	1965	2120	
	HU14	14	1 13/16	13 11/16	2 1/2	Min	28-16d	8-10dx1 1/2	1515	4165	4420	4505	3590	4050	4335	I9, F8, L12
			1 13/16	13 11/16	2 1/2	Max	36-16d	14-10dx1 1/2	2015	5055	5275	5420	4615	5000	5130	
HUCQ1.81/11-SDS	14	1 13/16	11	3	—	10-SDS 1/4"x1 3/4"	4-SDS 1/4"x1 3/4"	1505	2500	2875	3125	1800	2070	2250	I9, F23	
3 1/2 x 7 1/4	HU48/HUC48	14	3 9/16	6 13/16	2 1/2	Min	10-16d	4-10d	760	1490	1680	1805	1280	1445	1555	I9, L17, F6, L12
	3 9/16		6 13/16	2 1/2	Max	14-16d	6-10d	1135	2085	2350	2530	1795	2025	2180		
	HUS48/HUSC48	14	3 9/16	6 13/16	2	—	6-16d	6-16d	1550	1595	1815	1960	1365	1555	1680	I9, F8, L12, L17
	HGUS46	12	3 3/8	4 7/16	4	—	20-16d	8-16d	2155	4360	4885	5230	3750	4200	4500	I9, F23, L17
	HHUS48	14	3 3/8	7 1/8	3	—	22-16d	8-16d	2000	4210	4770	5140	3615	4095	4415	I9, F8, L12, L17
HGUS48	12	3 3/8	7 1/16	4	—	36-16d	12-16d	3235	7460	7460	7460	6415	6415	6415	I9, F23, L17	
3 1/2 x 9 1/4 - 9 1/2	U410	16	3 9/16	8 3/8	2	—	14-16d	6-10d	1110	2015	2285	2465	1735	1965	2120	I9, F8, L12, L17
	HUS410/HUSC410	14	3 9/16	8 15/16	2	—	8-16d	8-16d	2990	2125	2420	2615	1820	2070	2240	
			3 9/16	8 5/8	2 1/2	Min	14-16d	6-10d	1135	2085	2350	2530	1795	2025	2180	
	3 9/16	8 5/8	2 1/2	Max	18-16d	10-10d	1895	2680	3020	3250	2305	2605	2800	I9, F23, L12		
	HHUS410	14	3 3/8	9	3	—	30-16d	10-16d	3735	5635	6380	6880	4835		5480	
	HUCQ410-SDS	14	3 9/16	9	3	—	12-SDS 1/4"x2 1/2"	6-SDS 1/4"x2 1/2"	2510	4680	4955	4955	3370	3570	3570	
HGUS48	12	3 3/8	7 1/16	4	—	36-16d	12-16d	3235	7460	7460	7460	6415	6415	6415		
HGUS410	12	3 3/8	9 1/16	4	—	46-16d	16-16d	4095	9100	9100	9100	7825	7825	7825		
3 1/2 x 11 1/4 - 11 3/8	U410	16	3 9/16	8 3/8	2	—	14-16d	6-10d	1110	2015	2285	2465	1735	1965	2120	I9, F8, L12, L17
	HUS412/HUSC412	14	3 9/16	10 1/2	2	—	10-16d	10-16d	3635	2660	3025	3265	2275	2590	2795	
			3 9/16	10 9/16	2 1/2	Min	16-16d	6-10d	1135	2380	2685	2890	2050	2315	2490	
	3 9/16	10 9/16	2 1/2	Max	22-16d	10-10d	1895	3275	3695	3970	2820	3180	3425	I9, F23, L12, L17		
	HHUS410	14	3 3/8	9	3	—	30-16d	10-16d	3735	5635	6380	6880	4835		5480	
	HUCQ412-SDS	14	3 9/16	11	3	—	14-SDS 1/4"x2 1/2"	6-SDS 1/4"x2 1/2"	2510	5460	5560	5560	3930	4000	4000	
	HGUS48	12	3 3/8	7 1/16	4	—	36-16d	12-16d	3235	7460	7460	7460	6415	6415	6415	
	HGUS410	12	3 3/8	9 1/16	4	—	46-16d	16-16d	4095	9100	9100	9100	7825	7825	7825	
HGUS412	12	3 3/8	10 7/16	4	—	56-16d	20-16d	5045	9600	9600	9600	8255	8255	8255		
3 1/2 x 14	U414	16	3 9/16	10	2	—	16-16d	6-10d	1110	2305	2615	2820	1980	2245	2425	I9, F8, L12, L17
	HUS412/HUSC412	14	3 9/16	10 1/2	2	—	10-16d	10-16d	3635	2660	3025	3265	2275	2590	2795	
			3 9/16	13 3/8	2 1/2	Min	20-16d	8-10d	1515	2975	3360	3610	2565	2895	3110	
	3 9/16	13 3/8	2 1/2	Max	26-16d	12-10d	2015	3870	4365	4695	3330	3760	4045	I9, F23, L12		
	HHUS410	14	3 3/8	9	3	—	30-16d	10-16d	3735	5635	6380	6880	4835		5480	
	HGUS410	12	3 3/8	9 1/16	4	—	46-16d	16-16d	4095	9100	9100	9100	7825	7825	7825	
	HGUS414	12	3 3/8	12 7/16	4	—	66-16d	22-16d	5515	10100	10100	10100	8685	8685	8685	
HUCQ412-SDS	14	3 9/16	11	3	—	14-SDS 1/4"x2 1/2"	6-SDS 1/4"x2 1/2"	2510	5460	5560	5560	3930	4000	4000		
3 1/2 x 16	HU416/HUC416	14	3 9/16	13 3/8	2 1/2	Min	20-16d	8-10d	1515	2975	3360	3610	2565	2895	3110	I9, F8, L12, L17
			3 9/16	13 3/8	2 1/2	Max	26-16d	12-10d	2015	3870	4365	4695	3330	3760	4045	
	HGUS412	12	3 3/8	10 7/16	4	—	56-16d	20-16d	5045	9600	9600	9600	8255	8255	8255	I9, F23, L12
			3 3/8	12 7/16	4	—	66-16d	22-16d	5515	10100	10100	10100	8685	8685	8685	
HUCQ412-SDS	14	3 9/16	11	3	—	14-SDS 1/4"x2 1/2"	6-SDS 1/4"x2 1/2"	2510	5460	5560	5560	3930	4000	4000		

1. Uplift loads based on DF/SP lumber and have been increased for wind or earthquake loading with no further increase allowed. Reduce where other loads govern. For SPF/HF, use 0.86 x DF/SP Uplift Load for products requiring nails and 0.72 x DF/SP Uplift Load for products requiring screws.
 2. MIN nailing quantity and load values—fill all round holes;
 MAX nailing quantity and load values—fill all round and triangle holes.

3. Hangers sorted in order of recommended selection for best overall performance and installation value.
 4. Allowable downloads are based on a joist bearing capacity of 750 psi.
 5. NAILS: 16d = 0.162" dia. x 3 1/2" long, 10d = 0.148" dia. x 3" long, 10dx1 1/2 = 0.148" dia. x 1 1/2" long. See pages 22-23 for other nail sizes and information.

FACE MOUNT HANGERS – STRUCTURAL COMPOSITE LUMBER

Engineered Wood & Structural Composite Lumber Connectors

Actual Joist Size	Model No. ³	Ga	Dimensions				Fasteners ⁵		Allowable Loads ⁴						Code Ref.		
			W	H	B	Min/Max ²	Face	Joist	DF/SP Species Header				SPF/HF Species Header				
									Uplift (160)	Floor (100)	Snow (115)	Roof (125)	Floor (100)	Snow (115)		Roof (125)	
3½ x 18	HU416/HUC416	14	3⅞	13⅝	2½	Min	20-16d	8-10d	1515	2975	3360	3610	2565	2895	3110	I9, F8, L12, L17	
			3⅞	13⅝	2½	Max	26-16d	12-10d	2015	3870	4365	4695	3330	3760	4045		
	HGUS412	12	3⅝	10⅞	4	—	56-16d	20-16d	5045	9600	9600	9600	8255	8255	8255		I9, F23, L12
			HGUS414	3⅝	12⅞	4	—	66-16d	22-16d	5515	10100	10100	10100	8685	8685		
5¼ x 7¼	HU68/HUC68	14	5½	5⅞	2½	Min	10-16d	4-16d	900	1490	1680	1805	1280	1445	1555	I9, L12, F6	
			5½	5⅞	2½	Max	14-16d	6-16d	1345	2085	2350	2530	1795	2025	2180		
	HGUS5.50/8	12	5½	6⅞	4	—	36-16d	12-16d	3235	7460	7460	7460	6415	6415	6415	I9	
			5½	6⅞	4	—	36-16d	12-16d	3235	7460	7460	7460	6415	6415	6415		
5¼ x 9¼ - 9½	HU610/HUC610	14	5½	7⅞	2½	Min	14-16d	6-16d	1345	2085	2350	2530	1795	2025	2180	I9, F8, L12, L17	
			5½	7⅞	2½	Max	18-16d	8-16d	1795	2680	3020	3250	2305	2605	2800		
	HHUS5.50/10	12	5½	9	3	—	30-16d	10-16d	3735	5635	6380	6880	4835	5480	5910	I9, F23, L12	
			HUCQ610-SDS	5½	9	3	—	12-SDS ¼"x2½"	6-SDS ¼"x2½"	2520	4680	5380	5715	3370	3875		4115
5¼ x 11¼ - 11⅝	HU612/HUC612	14	5½	9⅞	2½	Min	16-16d	6-16d	1345	2380	2685	2890	2050	2315	2490	I9, F8, L12, L17	
			5½	9⅞	2½	Max	22-16d	8-16d	1795	3275	3695	3970	2820	3180	3425		
	HHUS5.50/10	12	5½	9	3	—	30-16d	10-16d	3735	5635	6380	6880	4835	5480	5910	I9, F23, L12	
			HUCQ612-SDS	5½	11	3	—	14-SDS ¼"x2½"	6-SDS ¼"x2½"	2520	5315	5315	5315	3825	3825		3825
5¼ x 14	HU616/HUC616	14	5½	12⅞	2½	Min	20-16d	8-16d	1795	2975	3360	3610	2565	2895	3110	I9, F8, L12, L17	
			5½	12⅞	2½	Max	26-16d	12-16d	2695	3870	4365	4695	3330	3760	4045		
	HHUS5.50/10	12	5½	9	3	—	30-16d	10-16d	3735	5635	6380	6880	4835	5480	5910	I9, F23, L12	
			HUCQ612-SDS	5½	11	3	—	14-SDS ¼"x2½"	6-SDS ¼"x2½"	2520	5315	5315	5315	3825	3825		3825
5¼ x 16	HU616/HUC616	14	5½	12⅞	2½	Min	20-16d	8-16d	1795	2975	3360	3610	2565	2895	3110	I9, F8, L12, L17	
			5½	12⅞	2½	Max	26-16d	12-16d	2695	3870	4365	4695	3330	3760	4045		
	HHUS5.50/10	12	5½	9	3	—	30-16d	10-16d	3735	5635	6380	6880	4835	5480	5910	I9, F23, L12	
			HUCQ612-SDS	5½	11	3	—	14-SDS ¼"x2½"	6-SDS ¼"x2½"	2520	5315	5315	5315	3825	3825		3825
5¼ x 18	HU616/HUC616	14	5½	12⅞	2½	Min	20-16d	8-16d	1795	2975	3360	3610	2565	2895	3110	I9, F8, L12, L17	
			5½	12⅞	2½	Max	26-16d	12-16d	2695	3870	4365	4695	3330	3760	4045		
	HHUS5.50/10	12	5½	9	3	—	30-16d	10-16d	3735	5635	6380	6880	4835	5480	5910	I9, F23, L12	
			HUCQ612-SDS	5½	11	3	—	14-SDS ¼"x2½"	6-SDS ¼"x2½"	2520	5315	5315	5315	3825	3825		3825
7 x 9¼ - 9½	HU410-2/ HUC410-2	14	7⅞	9⅞	2½	Min	14-16d	6-16d	1345	2085	2350	2530	1795	2025	2180	I9, F8, L12, L17	
			7⅞	9⅞	2½	Max	18-16d	8-16d	1795	2680	3020	3250	2305	2605	2800		
	HHUS7.25/10	12	7¼	9	3⅞	—	30-16d	10-16d	3735	5635	6380	6880	4835	5480	5910	I9, F23, L12	
			HGUS7.25/10	7¼	8⅞	4	—	46-16d	16-16d	4095	9100	9100	9100	7825	7825		7825
7 x 11¼ - 11⅝	HU412-2/ HUC412-2	14	7⅞	11⅞	2½	Min	16-16d	6-16d	1345	2380	2685	2890	2050	2315	2490	I9, L12, F8	
			7⅞	11⅞	2½	Max	22-16d	8-16d	1795	3275	3695	3970	2820	3180	3425		
	HHUS7.25/10	12	7¼	9	3⅞	—	30-16d	10-16d	3735	5635	6380	6880	4835	5480	5910	I9, F23, L12	
			HGUS7.25/12	7¼	10⅞	4	—	56-16d	20-16d	5045	9600	9600	9600	8255	8255		8255
7 x 14	HU414-2/ HUC414-2	14	7⅞	13⅞	2½	Min	20-16d	8-16d	1795	2975	3360	3610	2565	2895	3110	I9, L12, F8	
			7⅞	13⅞	2½	Max	26-16d	12-16d	2695	3870	4365	4695	3330	3760	4045		
	HHUS7.25/10	12	7¼	9	3⅞	—	30-16d	10-16d	3735	5635	6380	6880	4835	5480	5910	I9, F23, L12	
			HGUS7.25/14	7¼	12⅞	4	—	66-16d	22-16d	5515	10100	10100	10100	8685	8685		8685
7 x 16	HU414-2/ HUC414-2	14	7⅞	13⅞	2½	Min	20-16d	8-16d	1795	2975	3360	3610	2565	2895	3110	I9, L12, F8	
			7⅞	13⅞	2½	Max	26-16d	12-16d	2695	3870	4365	4695	3330	3760	4045		
	HHUS7.25/10	12	7¼	9	3⅞	—	30-16d	10-16d	3735	5635	6380	6880	4835	5480	5910	I9, F23, L12	
			HGUS7.25/14	7¼	12⅞	4	—	66-16d	22-16d	5515	10100	10100	10100	8685	8685		8685
7 x 18	HU414-2/ HUC414-2	14	7⅞	13⅞	2½	Min	20-16d	8-16d	1795	2975	3360	3610	2565	2895	3110	I9, L12, F8	
			7⅞	13⅞	2½	Max	26-16d	12-16d	2695	3870	4365	4695	3330	3760	4045		
	HHUS7.25/10	12	7¼	9	3⅞	—	30-16d	10-16d	3735	5635	6380	6880	4835	5480	5910	I9, F23, L12	
			HGUS7.25/14	7¼	12⅞	4	—	66-16d	22-16d	5515	10100	10100	10100	8685	8685		8685

7x14 to 30 For additional hangers see HGU/HHGU on page 224.

See footnotes on page 115.

THAI I-Joist & Structural Composite Lumber Hangers

Designed for I-joists, the THAI has extra long straps and can be field-formed to give height adjustability and top flange hanger convenience. Positive angle nailing helps eliminate splitting of the I-joist's bottom flange.

MATERIAL: THAI-2—14 gauge; all others—18 gauge **FINISH:** Galvanized

INSTALLATION: • Factory-order the THAI-2 for hanger width needed. See table for allowable widths.

- Use all specified fasteners. Verify that the header can take the fasteners specified in the table.
- Web stiffeners are required for all I-joists used with these hangers.
- When a total of 20 face nails are used in THAI straps, or 30 face nails are used in THAI-2 straps, the maximum load-carrying capacity is achieved.
- Reduce load given by allowable nail shear capacity for each nail less than maximum.
- A minimum nailing configuration is shown for top nailing installations. The strap must be field-formed over the top of the header by a minimum of 2 1/2".
- Uplift—Lowest face nails must be filled to achieve uplift loads.

CODES: See page 12 for Code Reference Key Chart.

Joist Dimensions		Model No.	Hanger Dimensions			Code Ref.
Width	Depth		W ¹	H	C	
1 1/2	9 1/4 - 14"	THAI222	1 1/16	22 1/2	9 3/8	18, L15, F7
1 3/4	9 1/4 - 14"	THAI1.81/22	1 3/16	22 3/4	9 1/4	
2	9 1/4 - 14"	THAI2.06/22	2 1/16	22 5/8	9 1/8	
2 1/16	9 1/4 - 14"	THAI2.1/22	2 1/8	22 5/16	9 1/8	
2 1/4 to 2 5/16	9 1/4 - 14"	THAI3522	2 5/16	22 1/2	9	
2 1/2	9 1/4 - 14"	THAI322	2 5/16	22 3/8	8 7/8	
3 1/2	9 1/4 - 14"	THAI422	3 3/16	21 7/8	8 3/8	
3 to 5 1/4	9 1/4 - 14"	THAI-2	3 3/8 to 5 1/16	21 1 1/16	8 3/16	

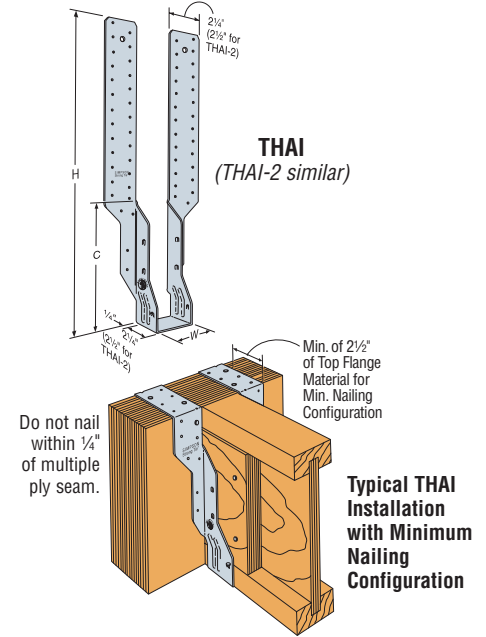

Nailing Options	Fasteners			Uplift (160)	Allowable Loads								
	Top	Face	Joist		LVL Header			DF/SP Header			SPF/HF Header		
					Floor (100)	Snow (115)	Roof (125)	Floor (100)	Snow (115)	Roof (125)	Floor (100)	Snow (115)	Roof (125)
THAI Minimum	4-10dx1 1/2	2-10dx1 1/2	2-10dx1 1/2	—	1400	1400	1400	1400	1400	1400	1060	1060	1060
	4-10d	2-10d	2-10dx1 1/2	—	1715	1715	1715	1835	1835	1835	1590	1590	1590
THAI Maximum	—	20-10d	2-10dx1 1/2	215	2200	2200	2200	2200	2200	2200	1920	2200	2200
THAI-2 Minimum	4-10d	2-10d	2-10dx1 1/2	—	2020	2020	2020	2020	2020	2020	2020	2020	2020
THAI-2 Maximum	—	30-10d	2-10dx1 1/2	215	3390	3900	4135	3390	3900	4135	2940	3310	3310

1. Uplift loads are based on DF/SP lumber and have been increased for wind or earthquake loading with no further increase allowed. Reduce where other loads govern. For SPF/HF use 0.86 x DF/SP uplift load.
2. The minimum header depth to achieve the maximum nail configuration is 16".

3. For the THAI3522 supporting a 2 1/4" joist, the download shall be the lesser of the table load or 1400 lbs.
4. **NAILS:** 10d = 0.148" dia. x 3" long, 10dx1 1/2 = 0.148" dia. x 1 1/2" long. See pages 22-23 for other nail sizes and information

LGU/MGU/HGU/HHGU High-Capacity Girder Hangers

The GU hangers are a high-capacity girder hangers designed for situations where the header and joist are flush at top. This part can be used for retrofit on the framing members after they are temporarily placed in position. It uses Simpson Strong-Tie® Strong-Drive® SDS Heavy-Duty Connector screws to make installation fast and easy, with no pre-drilling required.

MATERIAL: See table **FINISH:** Galvanized, HHGU—Simpson Strong-Tie® gray paint

INSTALLATION: • Use all specified fasteners. See General Notes.

- Install with 1/4"x2 1/2" Strong-Drive SDS Heavy-Duty Connector screws, which are provided with the GU's. (Note: lag screws will not achieve the same loads.)
- All multiple members must be fastened together to act as a single unit.
- Multiple member headers may require additional fasteners at the hanger locations. The quantity and location of the additional fasteners must be determined by the Designer.

OPTIONS: • Hot-dip galvanized available. Order as "X" version, specify HDG.

- Other seat widths available. Order as "X" version, specify width.
- See Hanger Options, pages 233-243, for one flange concealed option. MGU with W 4" or less and HGU with W 4 1/16" or less cannot be concealed.
- LGU, MGU and HGU hangers may be skewed up to 45°. See page 243.

CODES: See page 12 for Code Reference Key Chart.

These products are available with additional corrosion protection. Additional products on this page may also be available with this option, check with Simpson Strong-Tie for details.

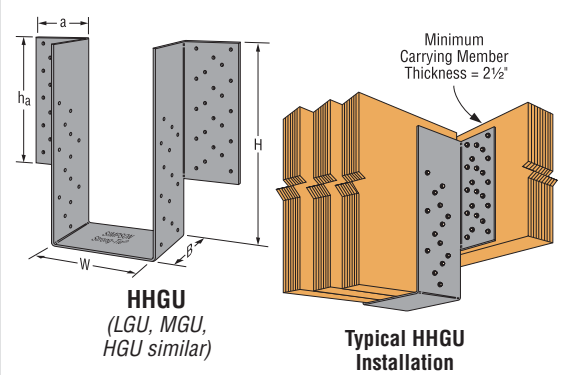

Actual Carried Beam Width	Model No.	Ga	Dimensions					Fasteners		Allowable Loads				Code Ref.
			W	H ² (min)	B	ha ³	a	Face	Joist	DF/SP		SPF/HF		
										Uplift 160	Download 100/115/125	Uplift 160	Download 100/115/125	
3 1/2	LGU3.63-SDS	10	3 3/8	8	4 1/2	7 3/8	3 3/4	16-SDS 1/4"x2 1/2"	12-SDS 1/4"x2 1/2"	5555	6720	4000	4840	19, F23, L12
3 1/2	MGU3.63-SDS	10	3 3/8	9 1/4	4 1/2	8 3/8	4	24-SDS 1/4"x2 1/2"	16-SDS 1/4"x2 1/2"	7260	9450	5225	6805	
3 1/2	HGU3.63-SDS	7	3 3/8	11	5 1/4	10 3/8	4 1 1/16	36-SDS 1/4"x2 1/2"	24-SDS 1/4"x2 1/2"	9895	14145	7125	10185	
5 1/4	MGU5.50-SDS	10	5 1/2	9 1/4	4 1/2	8 3/8	4	24-SDS 1/4"x2 1/2"	16-SDS 1/4"x2 1/2"	7260	9450	5225	6805	
5 1/4	HGU5.50-SDS	7	5 1/2	11	5 1/4	10 3/8	4 1 1/16	36-SDS 1/4"x2 1/2"	24-SDS 1/4"x2 1/2"	9895	14145	7125	10185	
5 1/4	HHGU5.50-SDS	3	5 1/2	13	5 1/4	12 3/8	4 1 1/16	44-SDS 1/4"x2 1/2"	28-SDS 1/4"x2 1/2"	14550	17845	10475	12850	
7	HGU7.25-SDS	7	7 1/4	11	5 1/4	10 3/8	4 1 1/16	36-SDS 1/4"x2 1/2"	24-SDS 1/4"x2 1/2"	9895	14145	7125	10185	
7	HHGU7.25-SDS	3	7 1/4	13	5 1/4	12 3/8	4 1 1/16	44-SDS 1/4"x2 1/2"	28-SDS 1/4"x2 1/2"	14550	17845	10475	12850	

1. Uplift loads have been increased for earthquake and wind loading, with no further increase allowed.
2. Specify H dimension. Maximum H = 30".
3. Header height must be at least as tall as flange height (ha).

TOP FLANGE HANGERS ITS/MIT/HIT Engineered Wood Products Hangers



This product is preferable to similar connectors because of a) easier installation, b) higher loads, c) lower installed cost, or a combination of these features.

Engineered Wood & Structural Composite Lumber Connectors

Simpson Strong-Tie offers a dedicated range of top flange I-joint hangers that meet the unique needs of I-joists while offering superior performance and ease of installation.

ITS

The innovative ITS sets the standard for engineered wood top flange hangers. The ITS installs faster and uses fewer nails than any other EWP top flange hanger. The new Strong-Grip™ seat and Funnel Flange™ features allow standard joist installation without requiring joist nails resulting in the lowest installed cost. The Strong-Grip seat firmly secures I-joists with flange thicknesses from 1 1/8" to 1 1/2".

MIT/HIT - Positive Angle Nailing (PAN)

PAN is specifically designed for I-joists when used with the MIT or HIT. With PAN, the nail hole material is not removed, but is formed to channel and confine the path of the nail at approximately 45°. PAN minimizes splitting of the flanges while permitting time-saving nailing from a better angle. See Top Flange tables on pages 124-132.

Refer to Joist Manufacturer's literature or appropriate Simpson Strong-Tie® Connector Selection Guide for actual joist sizes.

MATERIAL: ITS—18 gauge; MIT, HIT—16 gauge

FINISH: Galvanized

INSTALLATION:

- Use all specified fasteners. Verify that the header can take the required fasteners specified in the table.
- See product specific installation drawings on pages 108-109.
- ITS—no joist nailing required for standard I-joist installation without web stiffeners. When supporting I-joists with web stiffeners or rectangular SCL member 2-10dx1 1/2" must be installed into optional triangle joist nail holes for standard installation values.
- ITS—optional triangle nail holes may be used for additional load. See allowable load tables. Refer to technical bulletin T-OPTUPLIFT for additional options.
- MIT—optional triangle nail holes may be used for increased uplift capacity. See Optional Nailing For Increased Uplift table.
- HIT—closed PAN nail holes may be used for increased uplift capacity. See Optional Nailing For Increased Uplift table.
- For sloped joists up to 1/4:12 there is no reduction, between 1/4:12 and up to 1/2:12, tests show a 10% reduction in ultimate hanger strength. Local crushing of the bottom flange or excessive deflection may be limiting; check with joist manufacturer for specific limitations on bearing of this type.

ALLOWABLE LOADS:

- The ITS, MIT and HIT hangers have locations for optional nails if additional uplift is needed. Optional uplift nailing requires the addition of properly-secured web stiffeners. See the load tables for minimum required fasteners and allowable uplift loads.

OPTIONS:

- Because these hangers are fully die-formed, they cannot be modified. However these models will normally accommodate a skew of up to 5°.

CODES: See page 12 for Code Reference Key Chart.

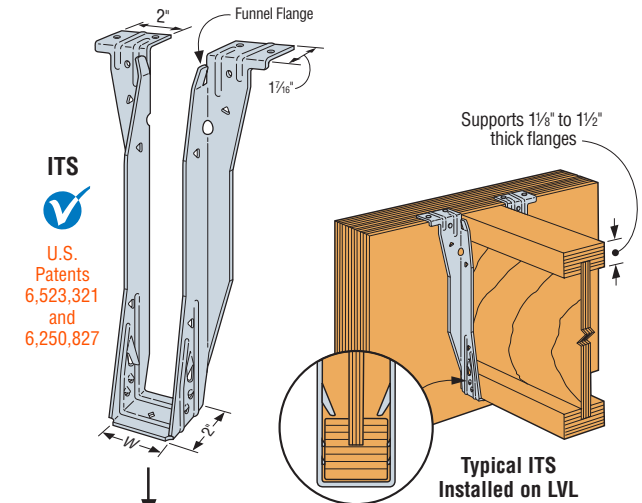

ITS
U.S. Patents 6,523,321 and 6,250,827

Supports 1 1/8" to 1 1/2" thick flanges

Typical ITS Installed on LVL

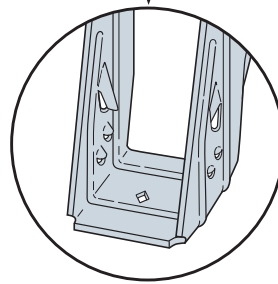

The Strong-Grip™ seat secures I-joists in position without joist nails

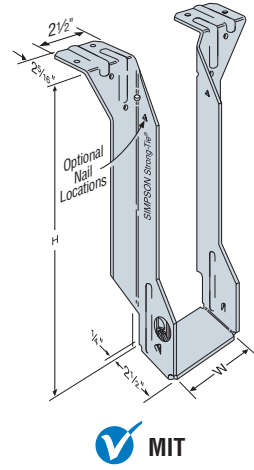

MIT

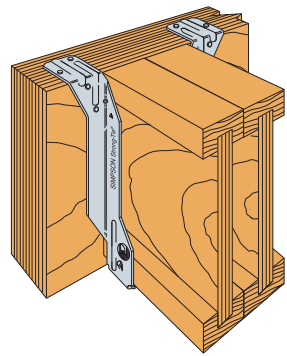

Typical MIT Installed on a Double LVL

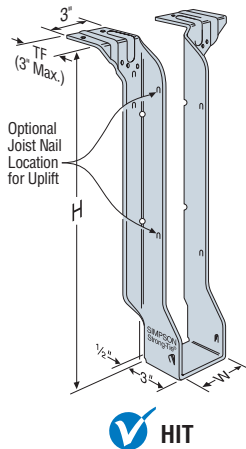

HIT

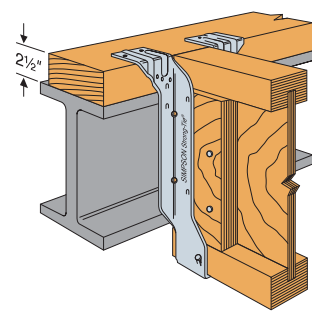

HIT Installation on a 3x Nailer mounted on a Steel Beam (ITS, MIT similar)

TOP FLANGE HANGERS ITS/MIT/HIT Engineered Wood Products Hangers

ITS INSTALLATION SEQUENCE

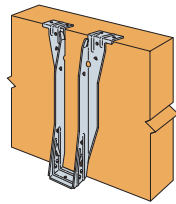

STEP 1
Attach the ITS to the header

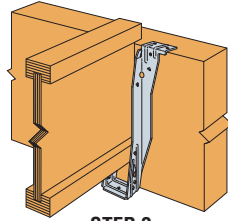

STEP 2
Slide the I-joint downward into the ITS until it rests above the Strong-Grip™ seat.

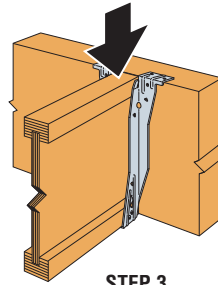

STEP 3
Firmly push or snap I-joint fully into the seat of the ITS.

POSITIVE ANGLE NAILING

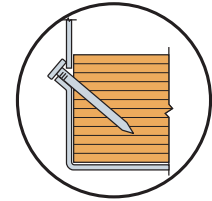

Correct Nailing
Approx. 45° angle

IT SERIES WITH VARIOUS HEADER APPLICATIONS

Model	Fasteners			Allowable Loads Header Type								Code Ref.
	Top	Face	Joist	Uplift ^{2,3} (160)	LVL ⁴	PSL	LSL	DF/SP	SPF/HF	DF/SCL ⁵ I-Joist	SPF/HF I-Joist	
ITS Series ¹⁰ (Standard Installation)	4-10dx1½	2-10dx1½	—	105	1395	1245	1625	1440	1140	1085	940	I19, L14, F18
	4-10d	2-10d	—	105	1550	1365	1780	1520	1150	—	—	
	4-16d	2-16d	—	105	1785	1735	1905	1635	1225	—	—	
ITS Series ^{7,10} (Alternate Installation)	4-10d	4-10d	—	105	1735	1595	1885	1955	1230	—	—	170
	4-16d	4-16d	—	105	1785	1735	1905	1955	1490	—	—	
	4-10d	4-10d	4-10dx1½	630	1735	1595	1885	1955	1230	—	—	
	4-16d	4-16d	4-10dx1½	630	1785	1735	1905	1955	1490	—	—	
MIT Series ¹⁰	4-10dx1½	4-10dx1½	2-10dx1½	215	2035	1500	1605	2035	1115	1230	885	I19, L14, F18
	4-10d	4-10d	2-10dx1½	215	2335	2000	1605	2245	1665	—	—	
	4-16d	4-16d	2-10dx1½	215	2550	2140	2115	2305	1665	—	—	
HIT Series	4-16d	6-16d	2-10dx1½	315	2550	2220	2500	2875	2000	—	—	

1. Loads may not be increased for duration of load.
2. Uplift loads are based on DF/SP lumber and have been increased for wind or earthquake loading with no further increase allowed. Reduce where other loads govern. For SPF/HF use 0.86 x DF/SP uplift load.
3. ITS uplift loads are valid for all lumber species and need not be reduced for duration of load.
4. Applies to LVL headers made primarily from Douglas Fir or Southern Pine. For LVL made primarily from Spruce Pine Fir or similar less dense veneers, use the values found in the SPF/HF column.
5. DF I-joists include flanges made from solid sawn Douglas Fir, LVL made primarily of Douglas Fir/Southern Pine, or LSL. For flanges with thicknesses from 1½ to 1¾, use 0.85 of the I-joint header load. For flanges with thicknesses from 1¾ to 1¼, use 0.75 of the I-joint header load.

6. SCL (structural composite lumber) is LVL, LSL, and Parallam® PSL.
 7. Web stiffeners required for the ITS Alternate Installation when installing optional joist nails for additional uplift load.
 8. Code Values are based on DF/SP header species.
 9. I-joists with flanges less than 1½" thick used in combination with hangers thinner than 14 gauge may deflect an additional ½ inch beyond the standard ⅛" limit.
 10. For 2¼" and 2⅞" wide joists, see tables on page 125 for allowable loads.
- Parallam® is a registered trademark of Weyerhaeuser.*

NAILS: 16d = 0.162" dia. x 3½" long, 16dx2½ = 0.162" dia. x 2½" long, 10d = 0.148" dia. x 3" long, 10dx1½ = 0.148" dia. x 1½" long. See pages 22-23 for other nail sizes and information.

NAILER TABLE

This table indicates various allowable loads for ITS/MIT/HIT hangers used on wood nailers. The header nail type must be substituted for those listed in other tables. See technical bulletin T-NAILERUPLFT for other uplift values and options.

Model	Nailer	Top Flange Nailing	Joist Nailing	Uplift ² (160)	Allowable Loads	
					DF/SP	SPF/HF
ITS Series	2x	6-10dx1½	—	105	1260	1260
	2x	6-10dx1½	2-10dx1½	355	1260	1260
	2-2x	6-10d	—	105	1220	1220
	2-2x	8-10d	4-10dx1½	630	1745	1530
	3x	6-16dx2½	—	105	1500	—
	3x	8-16dx2½	4-10dx1½	630	1540	—
	4x	6-16d	—	105	1525	—
MIT Series	4x	8-16d	4-10dx1½	630	1905	—
	2x	6-10dx1½	2-10dx1½	215	1475	1440
	2-2x	8-10d	2-10dx1½	215	1630	1255
	3x	8-16dx2½	2-10dx1½	215	1975	—
HIT Series	4x	8-16d	2-10dx1½	215	2250	—
	2-2x	10-10d	2-10dx1½	315	2595	—
	3x	10-16dx2½	2-10dx1½	315	2835	—
	4x	10-16d	2-10dx1½	315	2875	—

1. Uplift loads are based on DF/SP members only. See technical bulletin T-NAILERUPLFT for SPF/HF values.

OPTIONAL NAILING FOR INCREASED UPLIFT

Model	Fasteners			Allowable Uplift Loads (160)
	Top	Face	Joist	
ITS	4-10dx1½	4-10dx1½	4-10dx1½	630
	4-10d	4-10d	4-10dx1½	630
	4-16d	4-16d	4-10dx1½	630
MIT	4-10dx1½	4-10dx1½	4-10dx1½	575
	4-16d	4-16d	4-10dx1½	575
HIT	4-16d	6-16d	4-10dx1½	575
	4-16dx2½	6-16dx2½	4-10dx1½	575
	4-16d	6-16d	6-10dx1½	850

1. Loads are based on Doug Fir, and have been increased for wind or earthquake loading with no further increase allowed. Reduce where other loads govern.
2. Web stiffeners are required on I-joint for additional nailing.

TOP FLANGE HANGERS LBV/BA/B/HB I-Joist & Structural Composite Lumber Hangers



This product is preferable to similar connectors because of
a) easier installation, b) higher loads, c) lower installed cost,
or a combination of these features.

The BA hanger is a cost effective hanger targeted at high capacity I-joists and common Structural Composite Lumber applications. A min/max joist nail option gives dual use of this hanger. Minimum values featuring positive angle nailing are targeted at I-joist without web stiffeners requirement and the maximum nailing generates higher loads to support structural composite lumber. The unique two level embossment provides added stiffness to the top flange.

The newly improved LBV, B and HB hangers offer wide versatility for I-joists and structural composite lumber. The enhanced load capacity widens the range of applications for these hangers. The LBV still features positive angle nailing and does not require the use of web stiffeners for standard non modified I-joist installations.

See Top Flange tables on pages 124-132. See Hanger Options on pages 233-243 for hanger modifications, which may result in reduced loads.

MATERIAL: See tables on pages 124-132.

FINISH: LBV, B, BA and HB—Galvanized; all saddle hangers and all welded sloped and special hangers—Simpson Strong-Tie® gray paint. LBV, B, BA and HB may be ordered hot-dip galvanized; specify HDG.

INSTALLATION: • Use all specified fasteners. See General Notes and nailer table.

- LBV, B, BA and HB may be used for weld-on applications. Weld size to match material thickness (approximate thickness shown). The minimum required weld to the top flanges is 1/8" x 2" fillet weld to each side of each top flange tab for 14 and 12 gauge and 3/16" x 2" fillet weld to each side of each top flange tab for 7 gauge and 10 gauge. Distribute the weld equally on both top flanges. Welding cancels the top and face nailing requirements. Consult the code for special considerations when welding galvanized steel. The area should be well-ventilated, see page 17 for weld information. Weld on applications produce the maximum allowable down load listed. For uplift loads refer to technical bulletin T-WELDUPLFT.
- LBV hangers do not require the use of web stiffeners for non-sloped or non-skewed applications.
- B and HB hangers require the use of web stiffeners. BA MIN nailing does not require web stiffeners. BA MAX nailing requires the use of web stiffeners.
- Ledgers must be evaluated for each application separately. Check TF dimension, nail length and nail location on ledger.
- Refer to technical bulletin T-SLOPEJST for information regarding load reductions on selected hangers which can be used without modification to support joists which have shallow slopes (≤3/4:12).

OPTIONS: • LBV, B and HB

- Other widths are available; specify W dimension (the minimum W dimension is 1 1/8").
- The coating on special B hangers will depend on the manufacturing process used. Check with your Simpson Strong-Tie representative for details. Hot-dip galvanized available; specify HDG.
- Refer to technical bulletin T-BSERIES for the complete line of LBV, BA, B and HB hangers, including models not shown here, their available modification combinations and their associated reduction factors.
- Modified hangers have reduced loads, see Hanger Options, pages 233-243.

CODES: See page 12 for Code Reference Key Chart.

Model No.	Nailer	Top Flange Nailing	Uplift ¹ (160)	Allowable Loads	
				DF/SP	SPF/HF
LBV	2x	10-10dx1 1/2	265	2280	2085
	2-2x	10-10d	265	1955	1530
	3x	10-16dx2 1/2	265	2490	—
	4x	10-16d	265	2590	—
BA	2x	10-10dx1 1/2	265	2220	1755
	2-2x	14-10d	265	2695	2235
	3x	14-16dx2 1/2	265	3230	—
	4x	14-16d	265	3230	—
B	2-2x	14-10d	710	3615	2770
	3x	14-16dx2 1/2	825	3725	—
	4x	14-16d	825	3800	—
HB	4x	22-16d	1550	5500	—

NAILER TABLE

The table indicates the maximum allowable loads for LBV, BA, B and HB hangers used on wood nailers. Nailers are wood members attached to the top of a steel I-beam, concrete or masonry wall.

1. Uplift values are for DF/SP members only. LBV and BA hangers resist more uplift when web stiffeners are used. Refer to technical bulletin T-NAILERUPLFT for additional information.
2. See page 239 for reductions on modified hangers on nailers.
3. B hangers require 6-10dx1 1/2 joist nails to achieve published loads. For joist members 2 1/2" or wider, 16dx2 1/2" joist nails should be installed for additional uplift loads on the 3x and 4x nailer applications of 970 lbs. and 1010 lbs., respectively.

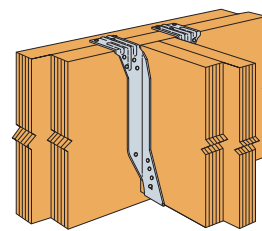
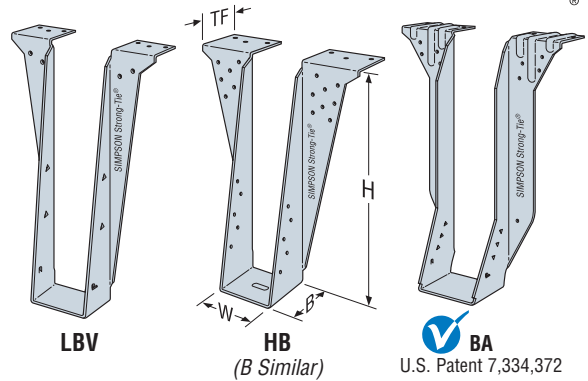

BA Installed LVL to LVL Max Nailing

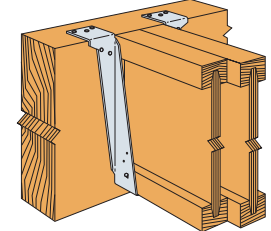

Typical Double LBV Hanger Installation

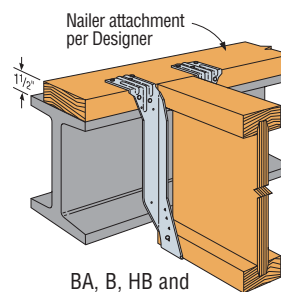

BA, B, HB and LBV are acceptable for nailer applications (BA shown on 2x nailer)

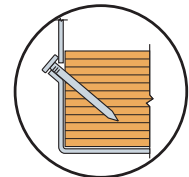

LBV features positive angle nailing, no web stiffeners are required

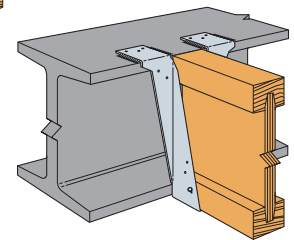

BA, B, HB and LBV are acceptable for weld-on applications (LBV shown). See Installation Information.

NAILS: 16d = 0.162" dia. x 3 1/2" long, 16dx2 1/2 = 0.162" dia. x 2 1/2" long, 10d = 0.148" dia. x 3" long, 10dx1 1/2 = 0.148" dia. x 1 1/2" long. See pages 22-23 for other nail sizes and information.

B SERIES WITH VARIOUS HEADER APPLICATIONS

Model Series	Fasteners			Allowable Loads Header Type								Code Ref.
	Top	Face	Joist	Uplift ³ (160)	LVL ⁸	PSL	LSL	DF/SP	SPF/HF	I-Joist ⁹		
										DF/SCL	SPF/HF	
LBV (Min)	6-10dx1 1/2	4-10dx1 1/2	2-10dx1 1/2	265	2295	2610	2270	1790	1835	1495	1340	I19, L14, F21
	6-10d	4-10d	2-10dx1 1/2	265	2295	2610	2645	2310	2060	—	—	
	6-16d	4-16d	2-10dx1 1/2	265	2910	2885	3190	2590	2060	—	—	
LBV (Max)	6-10dx1 1/2	4-10dx1 1/2	6-10dx1 1/2	635	2295	2610	2270	1790	1835	1495	1350	
	6-10d	4-10d	6-10dx1 1/2	785	2295	2610	2645	2310	2060	—	—	
	6-16d	4-16d	6-10dx1 1/2	895	2910	2885	3190	2590	2060	—	—	
BA (Min)	6-10dx1 1/2	10-10dx1 1/2	2-10dx1 1/2	—	—	—	—	—	—	1495	1495	
	6-10d	10-10d	2-10dx1 1/2	265	3230	3630	4005	3080	2425	—	—	
BA (Max)	6-16d	10-16d	2-10dx1 1/2	265	4015	3705	4005	3435	2665	—	—	
	6-10d	10-10d	8-10dx1 1/2	1170	3555	3630	4120	3625	2465	—	—	
B ²	6-16d	10-16d	8-10dx1 1/2	1170	4715	4320	4500	3800	2665	—	—	
	6-10d	8-10d	6-10dx1 1/2	990	3555	3195	3640	3625	2190	—	—	
HB ²	6-16d	8-16d	6-16dx2 1/2	1010	4135	3355	4500	3800	2650	—	—	
	6-16d	16-16d	10-16dx2 1/2	2610	5815	5640	6395	5650	3820	—	—	

1. This table assumes joists with F_{cL} = 750 psi. For other joists, check that bearing and joist nails are adequate.
2. Loads for B's and HB's assume a joist width of 2 1/2" or greater.
3. Uplift loads are based on DF/SP lumber and have been increased for wind or earthquake loading with no further increase allowed. Reduce where other loads govern. For SPF/HF use 0.86 x DF/SP uplift load.
4. Loads may not be increased for short term loading.
5. Web stiffeners required when more than two joist nails are used.
6. SCL (structural composite lumber) is LVL (laminated veneer lumber), LSL (laminated strand lumber), and Parallam® PSL.
7. Code values are based on DF/SP header species.
8. Applies to LVL headers made primarily from Douglas Fir or Southern Pine. For LVL made primarily from Spruce-Pine-Fir or similar less dense veneers, use the values found in the SPF/HF column.
9. DF I-joists include flanges made from solid sawn Douglas Fir, LVL made primarily of Douglas Fir/Southern Pine, or LSL. For flanges with thicknesses from 1 3/8" to 1 1/2", use 0.85 of the I-joist header load. For flanges with thicknesses from 1" to 1 1/4", use 0.75 of the I-joist header load.

Parallam® is registered trademark of Weyerhaeuser.

TOP FLANGE HANGERS W/WP/WPU/WM/WMU/HW/HWU I-Joist & Structural Composite Lumber Hangers

The W, WP, WPU, HWU and HW series are designed to hang joists, purlins or beams. WM and WMU hangers are designed for use on standard 8" grouted masonry block wall construction. Some models have an "I" in the model number which indicates a size specific for an I-Joist and have the same properties and modifications as the standard series.

MATERIAL: See tables on pages 124-132.

FINISH: Simpson Strong-Tie® gray paint; HDG available. Contact Simpson Strong-Tie.

INSTALLATION: • Use all specified fasteners. WM—two 16d duplex nails must be installed into the top flange and embedded into the grouted wall. Verify that the header can take the required fasteners specified in the table.

- Hangers may be welded to steel headers with 1/8" for W, 3/16" for WP, WPU, and 1/4" for HW, HWU by 1 1/2" fillet welds located at each end of the top flange, see page 17 for weld information. Weld-on applications produce maximum allowable load listed. For uplift loads refer to technical bulletin T-WELDUPLFT (WPU and HWU hangers only).
- Hangers can support multi-ply carried members; the individual members must be secured together to work as a single unit before installation into the hanger.
- Hangers can support joists sloped up to 1/4:12 using table loads. For joists sloping between 1/4:12 and 3/4:12 use 85% of the table loads.
- Web stiffeners are required for standard joist nailing configuration with these hangers.
- **WM/WMU MID-WALL INSTALLATION:** Installed between blocks with duplex nails cast into grout with a minimum of one grouted course above and below the top flange grouted and one #5 vertical rebar minimum 24" long in each adjacent cell.
- **WM/WMU TOP-OF-WALL INSTALLATION:** Install on top of wall to a grouted beam with Titen® masonry screws.

OPTIONS: • See Hanger Options, pages 233-243 for hanger modifications and associated load reductions.

CODES: See page 12 for Code Reference Key Chart.

Model	Nailer	Top Flange Nailing	Uplift ¹ (160)	Allowable Loads	DF/SP	SPF/HF
W	2x	2-10dx1 1/2"	—	1600	1600	—
	2-2x	2-10d	—	1665	—	—
	3x	2-16dx2 1/2"	—	1765	—	—
	4x	2-10d	—	2200	—	—
WP	2x	2-10dx1 1/2"	—	2525	2500	—
	2-2x	2-10d	—	3255	3255	—
	3x	2-16dx2 1/2"	—	3000	2510	—
	4x	2-10d	—	3255	3255	—
WPU	2-2x	7-10d	710	3255	—	—
	3x	7-16dx2 1/2"	970	3000	—	—
	4x	7-16d	1095	3255	—	—
HW	2-2x	4-10d	—	4860	—	—
	3x	4-16dx2 1/2"	—	4845	—	—
	4x	4-16d	—	5285	—	—
HWU	2-2x	8-16dx2 1/2"	710	5430	—	—
	3x	8-16dx2 1/2"	970	5430	—	—
	4x	8-16d	1160	5430	—	—

NAILER TABLE

The table indicates the maximum allowable loads for W, WP and HW hangers used on wood nailers. Nailers are wood members attached to the top of a steel I-beam, concrete or masonry wall.

1. Uplift values for the WPU and HWU hangers are for depths ≤ 18" and are for DF/SP values only. Refer to uplift values in table below for taller depths.
2. Attachment of nailer to supporting member is the responsibility of the Designer.

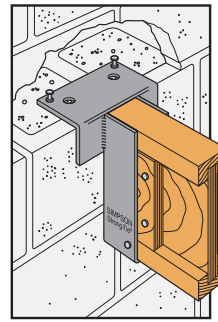
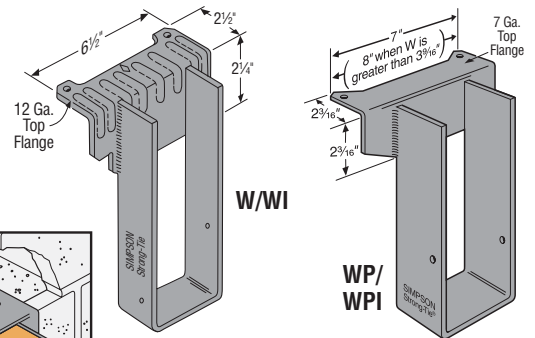
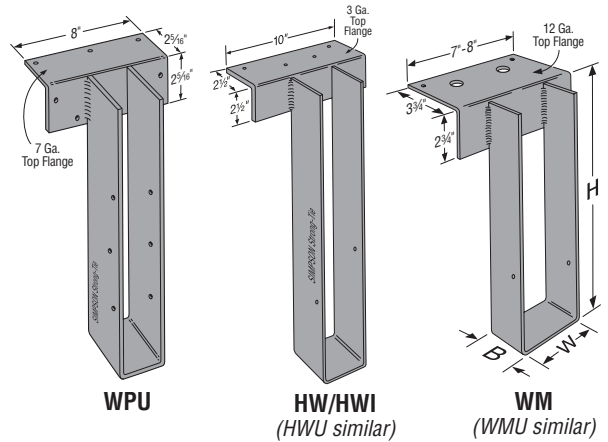

Typical WM Installation

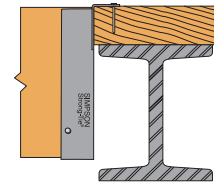

Correct Nailer Attachment

Some model configurations may differ from those shown. Contact Simpson Strong-Tie for details.

W SERIES WITH VARIOUS HEADER APPLICATIONS

Model	Joist		Fasteners			Allowable Loads Header Type							Code Ref.	
	Width	Depth	Top	Face	Joist	Uplift (160)	LVL ⁴	PSL	LSL	DF/SP	SPF/HF	I-Joist		Masonry ⁵
W	1 1/2 to 4	3 1/2 to 30	2-10dx1 1/2"	—	2-10dx1 1/2"	—	1635	1740	—	1600	1415	—	—	170
	1 1/2 to 4	3 1/2 to 30	2-10d	—	2-10dx1 1/2"	—	2150	2020	—	2200	1435	—	—	I19, L14, F18
	1 1/2 to 4	3 1/2 to 30	2-16d	—	2-10dx1 1/2"	—	2335	1950	2335	1765	1435	—	—	
WM	1 1/2 to 4	3 1/2 to 30	2-16d DPLX	—	2-10dx1 1/2"	—	MID-WALL INSTALLATION						4175	L16
	1 1/2 to 4	3 1/2 to 30	2-1/4x1 1/4" Titen ⁶	—	2-10dx1 1/2"	—	TOP-OF-WALL INSTALLATION						3380	
WMU	1 1/2 to 7 1/2	9 to 28	2-16d DPLX	4-1/4x1 1/4" Titen ⁶	6-10dx1 1/2"	625	MID-WALL INSTALLATION						4175	170
	1 1/2 to 7 1/2	9 to 28	2-1/4x1 1/4" Titen ⁶	4-1/4x1 1/4" Titen ⁶	6-10dx1 1/2"	545	TOP-OF-WALL INSTALLATION						3380	
WP	1 1/2 to 7 1/2	3 1/2 to 30	2-10dx1 1/2"	—	2-10dx1 1/2"	—	2865	3250	—	2500	2000	2030	—	I19, L14, F18
	1 1/2 to 7 1/2	3 1/2 to 30	2-10d	—	2-10dx1 1/2"	—	2525	3250	3650	3255	2525	—	—	
	1 1/2 to 7 1/2	3 1/2 to 30	2-16d	—	2-10dx1 1/2"	—	3635	3320	3650	3255	2600	—	—	
WPU	1 1/2 to 5 1/2	7 1/4 to 18	3-16d	4-16d	6-10dx1 1/2"	1095	4700	4880	3650	4165	4165	—	—	I19, L14, F18
	1 1/2 to 5 1/2	18 1/2 to 28	3-16d	4-16d	6-10dx1 1/2"	390	4700	4880	3650	4165	4165	—	—	
HW	1 1/2 to 7 1/2	3 1/2 to 32	4-10d	—	2-10dx1 1/2"	—	3100	4000	—	5285	3100	—	—	I19, L14, F18
	1 1/2 to 7 1/2	3 1/2 to 32	4-16d	—	2-10dx1 1/2"	—	5100	4000	4500	5285	3665	—	—	
HWU	1 3/4 to 3 1/2	9 to 18	4-16d	4-16d	6-10dx1 1/2"	1160	6335	5500	5535	6335	5415	—	—	I19, L14, F18
	1 3/4 to 3 1/2	18 1/2 to 28	4-16d	4-16d	6-10dx1 1/2"	965	6335	5500	5535	6335	5415	—	—	
	1 3/4 to 3 1/2	28 1/2 to 32	4-16d	4-16d	8-10dx1 1/2"	985	6335	5500	5535	6335	5415	—	—	
	4 1/2 to 7	9 to 18	4-16d	4-16d	6-10dx1 1/2"	1160	6000	5500	5535	6000	5415	—	—	
	4 1/2 to 7	18 1/2 to 28	4-16d	4-16d	6-10dx1 1/2"	965	6000	5500	5535	6000	5415	—	—	
	4 1/2 to 7	28 1/2 to 32	4-16d	4-16d	8-10dx1 1/2"	985	6000	5500	5535	6000	5415	—	—	

1. Uplift loads are based on DF/SP lumber and have been increased 60% for wind or earthquake loading with no further increase allowed. For normal loading applications such as cantilever construction refer to Simpson Strong-Tie® Connector Selector™ software or conservatively divide the uplift load by 1.6. For SPF/HF use 0.86 x DF/SP uplift load.
2. Applies to LVL headers made primarily from Douglas Fir or Southern Pine. For LVL made primarily from Spruce Pine Fir or similar less dense veneers, use the values found in the SPF/HF column.
3. WP quantity of nail holes in top flange varies.
4. Top Flange Hangers on the following pages with "I" in the model name (e.g. HWI) use the same design information in the above tables for the models without the "I" in the name (e.g. HW).
5. Minimum F_m = 1500 psi. See Installation Notes on page 173.
6. For hanger heights exceeding the joist height, the allowable load is 0.50 of the table load.
7. **NAILS:** 16d and 16d DPLX = 0.162" dia. x 3 1/2" long, 10d = 0.148" dia. x 3" long, 10dx1 1/2 = 0.148" dia. x 1 1/2" long. See pages 22-23 for other nail sizes and information. Parallax® is a registered trademark of Weyerhaeuser.

GLTV/HGLTV Heavy Duty Hangers

GLTV and HGLTV hangers are designed for structural composite lumber header applications that require high loads. The top flange nails are sized and specifically located to prevent degradation of the header due to splitting of laminations.

For heavy loads with a face-mount application, see the HGUS and GU series.

MATERIAL: Top flange—3 gauge; Stirrups—7 gauge

FINISH: Simpson Strong-Tie® gray paint; HDG available. Contact Simpson Strong-Tie.

INSTALLATION: • Use all specified fasteners. Verify that the header can take the required fasteners specified in the table.

- This series may be used for weld-on applications. Minimum required weld is $\frac{3}{16}$ " x $2\frac{1}{2}$ " fillet weld at each end of the top flange for GLTV, and a $\frac{1}{4}$ " x $2\frac{1}{2}$ " fillet weld at each end of the top flange for HGLTV, see page 17 for weld information. Weld-on applications produce maximum loads listed. For uplift loads refer to T-WELDUPLFT.
- Web stiffeners are required with I-joists using this hanger style.
- GLTV or HGLTV hangers may be installed on ledgers provided the ledgers are made of 4x solid sawn or $3\frac{1}{2}$ " SCL shown in the table below. Thinner lumber must be evaluated by the building Designer.
- HGLTV hangers should not be attached to nailers.

OPTIONS: • Hot-dip galvanized: specify HDG.

- See Hanger Options, pages 233-243. Saddle hanger versions are available in some engineered wood sizes.

CODES: See page 12 for Code Reference Key Chart.

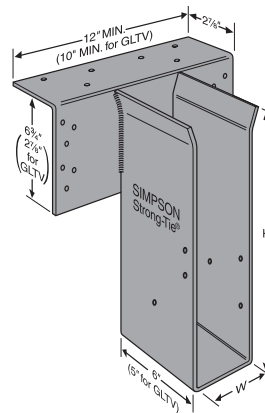

HGLTV
(GLTV similar)

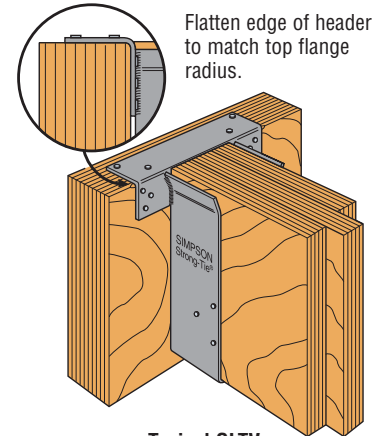

Typical GLTV Installation

These products are available with additional corrosion protection. Additional products on this page may also be available with this option, check with Simpson Strong-Tie for details.

Model No.	Fasteners			Allowable Loads Header Type							Code Ref.
	Top	Face	Joist	Uplift (160)	LVL ⁴	PSL	LSL	DF/SP	SPF/HF	Nailer ⁵	
GLTV series	4-16d	6-16d	6-16d	1295	7500	7400	5915	7200	5145	5930	I19, L14, F18
HGLTV series	6-16d	12-16d	6-16d	1295	10585	9485	9500	8835	6770	—	

1. Uplift loads have been increased for wind or earthquake loading with no further increase allowed. Reduce where other loads govern.
2. Uplift loads only apply when "H" is 28" or less. Uplift loads for nailer applications is limited to 710 lbs.
3. For hanger heights exceeding the joist height, the allowable load is 0.50 of the table load.

4. Applies to LVL headers made primarily from Douglas Fir or Southern Pine. For LVL made primarily from Spruce Pine Fir or similar less dense veneers, use the values found in the SPF/HF column.
5. Nailer shall be minimum 2-2x, 3x or 4x DF/SP. Use 16dx2 $\frac{1}{2}$ " nails.
6. For SCL products made primarily from Douglas Fir or Southern Pine use 1640 lbs. for uplift. For SPF member use 1115 lbs. for uplift.
7. **NAILS:** 16d = 0.162" dia. x 3 $\frac{1}{2}$ " long. See pages 22-23 for other nail sizes and information.

EGQ High Capacity Hanger



This product is preferable to similar connectors because of a) easier installation, b) higher loads, c) lower installed cost, or a combination of these features.

The EGQ hanger is a high capacity top flange connector designed for use with Structural Composite Lumber beams. It utilizes Simpson Strong-Tie® Strong-Drive® SDS Heavy-Duty Connector screws for higher capacity and ease of installation. Available in standard SCL widths and made to specified heights. SDS screws are included.

MATERIAL: Top flange—3 gauge; Stirrups—7 gauge

FINISH: Simpson Strong-Tie gray paint; HDG available. Contact Simpson Strong-Tie.

INSTALLATION: • Use all specified fasteners. See General Notes.

- Install with $\frac{1}{4}$ " x 3" Strong-Drive SDS Heavy-Duty Connector screws, which are provided with the EGQ. (Lag screws will not achieve the same load.)
- All multiple members must be fastened together to act as a single unit.
- Multiple member headers may require additional fasteners at hanger locations. Quantity and location to be determined by designer. See Strong-Drive SDS Heavy-Duty Connector screw section for additional information and applications.

OPTIONS: • See Hanger Options pages 233-243.

CODES: See page 12 for Code Reference Key Chart.

These products are available with additional corrosion protection. Additional products on this page may also be available with this option, check with Simpson Strong-Tie for details.

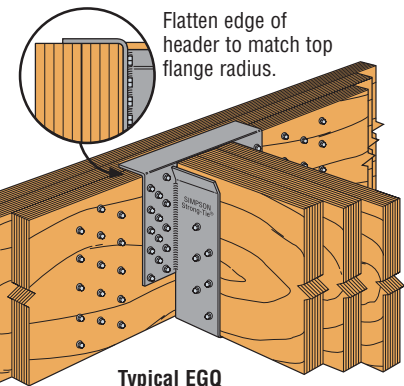

3 $\frac{1}{2}$ x 11 $\frac{1}{8}$ Minimum

Typical EGQ Installation

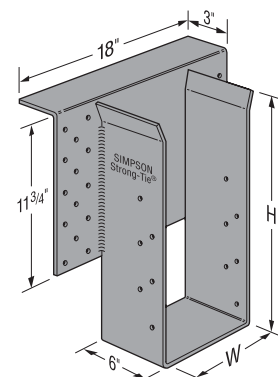

EGQ

Model No.	Joist or Purlin Size	Dimensions			Fasteners		Allowable Loads Header Type				Code Ref.
		W	Min H	Header	Joist	Uplift (160)	LVL/LSL	PSL	DF/SP		
EGQ3.62-SDS3	3 $\frac{1}{2}$	3 $\frac{3}{8}$	11 $\frac{1}{4}$	28-SDS $\frac{1}{4}$ "x3"	12-SDS $\frac{1}{4}$ "x3"	6365	19800	18680	19800	I19, L14	
EGQ5.50-SDS3	5 $\frac{1}{4}$	5 $\frac{1}{2}$	11 $\frac{1}{4}$	28-SDS $\frac{1}{4}$ "x3"	12-SDS $\frac{1}{4}$ "x3"	6365	19800	18680	19800		
EGQ7.25-SDS3	7	7 $\frac{1}{4}$	11 $\frac{1}{4}$	28-SDS $\frac{1}{4}$ "x3"	12-SDS $\frac{1}{4}$ "x3"	6365	19800	18680	19800		

1. Loads are based on 750 psi wood bearing for SCL.
2. "Min H" is the minimum H dimension that may be specified.
3. Uplift loads have been increased for wind or earthquake loading with no further increase allowed. For normal loading such as in cantilever construction use an uplift value of 4800 lbs.

MSC Multiple Seat Connector

The MSC supports the ridge and two valleys for roof construction. Ideal for dormer roof applications.

MATERIAL: Top flange—3 gauge, Stirrups—11 gauge (MSC2 and MSC1.81), 7 gauge (MSC4 and MSC5)

FINISH: Simpson Strong-Tie® gray paint; HDG available. Contact Simpson Strong-Tie.

INSTALLATION: • Distribute the total load evenly about the centerline to avoid eccentric loading.

- Fasten all built-up members together as one unit.
- Net height will be calculated based on specified valley member depth and slope by the factory unless noted otherwise.

SLOPED AND/OR SKEWED VALLEYS

- The valley stirrups can be sloped **down** to 45° and skewed from 25° to 45°. (MSC5 skewed 20°-45°.)
- The total design load of the hanger is split between the ridge (20%) and each valley (40%).
- MSC connectors can be used for two valley connections with no ridge member. Divide the total load by two for each valley load.
- Many combinations of joist sizes, slopes and skews can be manufactured (refer to worksheet T-MSC-WS).

CODES: See page 12 for Code Reference Key Chart.

These products are available with additional corrosion protection. Additional products on this page may also be available with this option, check with Simpson Strong-Tie for details.

Model No.	Dimensions				Fasteners		Hips		Allowable Loads DF/SP			Code Ref.
	W	H (Min)	TF	L	Header	Joist	Max. Skew	Max. Slope	Floor/Snow/Roof (100/115/125)			
									Valley	Ridge	Total	
MSC2	1 1/16"	5 1/2"	2 7/8"	12"	10-16d	18-10dx1 1/2"	45°	0°	2535	1265	6335	I19, L14, F18
								45°	2010	1005	5025	
MSC1.81	1 1/16"	5 1/2"	2 7/8"	12"	10-16d	18-10dx1 1/2"	45°	0°	2535	1265	6335	
								45°	2010	1005	5025	
MSC4	3 9/16"	7 1/2"	2 7/8"	18"	10-16d	18-10d	45°	0°	3335	1665	8335	
								45°	3335	1665	8335	
MSC5	5 1/4"	9 1/2"	2 7/8"	26"	13-16d	18-16d	45°	0°	6450	3220	16125	
								45°	6290	3145	15725	

1. Valley loads are for each valley.
2. Other valley-ridge load distributions are allowed provided the sum of all three carried members is distributed symmetrically about the center of the hanger and combined do not exceed the total load.
3. MSC4 is also available in 3 1/8" Glulam width.
4. MSC5 is also available in widths up to 5 1/2". W2 minimum width is 3 1/2".
5. MSC4 is also available in widths down to 1 1/16". Use 10dx1 1/2" nails and MSC2 allowable loads.
6. Refer to technical bulletin T-MSC-WS for the hip valley rafter pitch conversion table.
7. **NAILS:** 16d = 0.162" dia. x 3 1/2" long, 10d = 0.148" dia. x 3" long, 10dx1 1/2" = 0.148" dia. x 1 1/2" long. See pages 22-23 for other nail sizes and information.

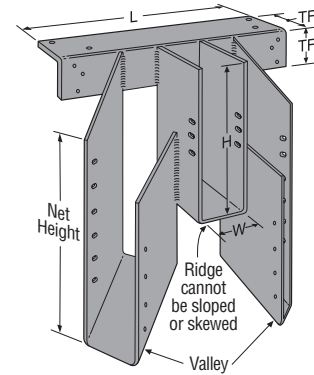

MSC4 with Valley Sloped and Skewed 45°

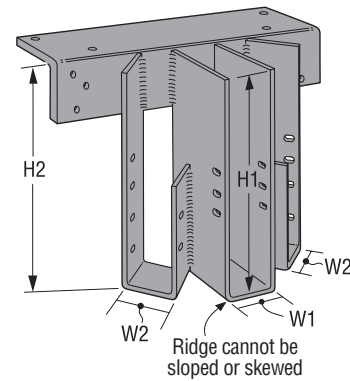

MSC1.81 with Valley Skewed 45° and Sloped 0°

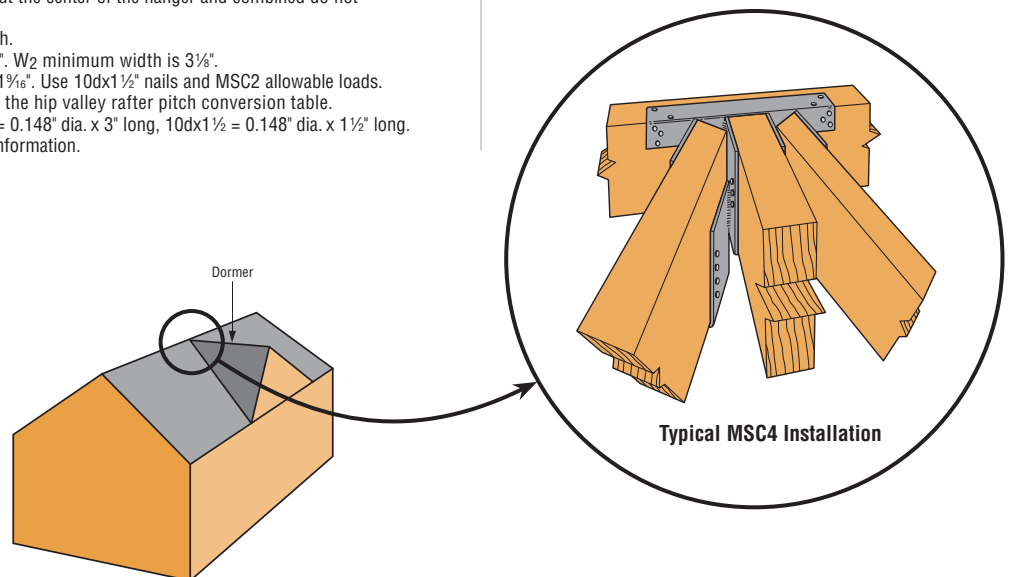

TOP FLANGE HANGERS – I-JOISTS & SCL

Engineered Wood & Structural Composite Lumber Connectors

Actual Joist Size	Model No.	Web/Stiff Req'd	Ga	Dimensions				Fasteners ⁵			Allowable Loads Header Type ^{1,2,6}						
				W	H	B	TF	Solid Header		Joist	Uplift (160)	LVL	PSL	LSL	DF/SP	SPF/HF	DF/SCL I-Joist ³
								Top	Face								
1½ x 9¼	ITS1.56/9.25	—	18	1⅝	9⅞	2	1⅞	4-10d	2-10d	—	105	1550	1365	1780	1520	1150	1085
	LBV1.56/9.25	—	14	1⅝	9¼	3	2½	6-16d	4-16d	2-10dx1½	265	2910	2885	3190	2590	1925	1495
	WP29.25	✓	12	1⅝	9¼	4	2⅞	2-16d	—	2-10dx1½	—	3635	3320	3635	3255	2600	2030
1½ x 9½	ITS1.56/9.5	—	18	1⅝	9⅞	2	1⅞	4-10d	2-10d	—	105	1550	1365	1780	1520	1150	1085
	LBV1.56/9.5	—	14	1⅝	9½	3	2½	6-16d	4-16d	2-10dx1½	265	2910	2885	3190	2590	1925	1495
	WP29.5	✓	12	1⅝	9½	4	2⅞	2-16d	—	2-10dx1½	—	3635	3320	3635	3255	2600	2030
1½ x 11¼	LBV1.56/11.25	—	14	1⅝	11¼	3	2½	6-16d	4-16d	2-10dx1½	265	2910	2885	3190	2590	1925	1495
	WP211.25	✓	12	1⅝	11¼	4	2⅞	2-16d	—	2-10dx1½	—	3635	3320	3635	3255	2600	2030
1½ x 11⅞	ITS1.56/11.88	—	18	1⅝	11⅞	2	1⅞	4-10d	2-10d	—	105	1550	1365	1780	1520	1150	1085
	LBV1.56/11.88	—	14	1⅝	11⅞	3	2½	6-16d	4-16d	2-10dx1½	265	2910	2885	3190	2590	1925	1495
	WP211.88	✓	12	1⅝	11⅞	4	2⅞	2-16d	—	2-10dx1½	—	3635	3320	3635	3255	2600	2030
1½ x 14	LBV1.56/14	—	14	1⅝	14	3	2½	6-16d	4-16d	2-10dx1½	265	2910	2885	3190	2590	1925	1495
1½ x 16	LBV1.56/16	—	14	1⅝	16	3	2½	6-16d	4-16d	2-10dx1½	265	2910	2885	3190	2590	1925	1495
1¾ x 7¼	BA1.81/7.25 (Min.)	—	14	1⅝	7¼	3	2½	6-16d	10-16d	2-10dx1½	265	4015	3705	4005	3435	2665	1495
	BA1.81/7.25 (Max.)	✓	14	1⅝	7¼	3	2½	6-16d	10-16d	8-10dx1½	1170	4715	4320	4500	3800	2665	1495
	LBV1.81/7.25	—	14	1⅝	7¼	3	2½	6-16d	4-16d	2-10dx1½	265	2910	2885	3190	2590	2060	1495
	WP1.81/7.25	✓	12	1⅝	7¼	3½	2⅞	2-16d	—	2-10dx1½	—	3635	3320	3635	3255	2600	2030
1¾ x 9¼	LBV1.81/9.25	—	14	1⅝	9¼	3	2½	6-16d	4-16d	2-10dx1½	265	2910	2885	3190	2590	2060	1495
	WP9.25	✓	12	1⅝	9¼	3½	2⅞	2-16d	—	2-10dx1½	—	3635	3320	3635	3255	2600	2030
	WPU1.81/9.25	✓	12	1⅝	9¼	4	2⅞	3-16d	4-16d	6-10dx1½	1095	4700	4880	3650	4165	4165	—
1¾ x 9½	ITS1.81/9.5	—	18	1⅝	9⅞	2	1⅞	4-10d	2-10d	—	105	1550	1365	1780	1520	1150	1085
	MIT9.5	—	16	1⅝	9½	2½	2⅞	4-16d	4-16d	2-10dx1½	215	2550	2140	2115	2305	1665	1230
	BA1.81/9.5 (Min.)	—	14	1⅝	9½	3	2½	6-16d	10-16d	2-10dx1½	265	4015	3705	4005	3435	2665	1495
	BA1.81/9.5 (Max.)	✓	14	1⅝	9½	3	2½	6-16d	10-16d	8-10dx1½	1170	4715	4320	4500	3800	2665	1495
	LBV1.81/9.5	—	14	1⅝	9½	3	2½	6-16d	4-16d	2-10dx1½	265	2910	2885	3190	2590	2060	1495
	WP9	✓	12	1⅝	9½	4½	2⅞	2-16d	—	2-10dx1½	—	3635	3320	3635	3255	2600	2030
1¾ x 11¼	LBV1.81/11.25	—	14	1⅝	11¼	3	2½	6-16d	4-16d	2-10dx1½	265	2910	2885	3190	2590	2060	1495
	WPU1.81/11.25	✓	12	1⅝	11¼	4	2⅞	3-16d	4-16d	6-10dx1½	1095	4700	4880	3650	4165	4165	—
1¾ x 11⅞	ITS1.81/11.88	—	18	1⅝	11⅞	2	1⅞	4-10d	2-10d	—	105	1550	1365	1780	1520	1150	1085
	MIT11.88	—	16	1⅝	11⅞	2½	2⅞	4-16d	4-16d	2-10dx1½	215	2550	2140	2115	2305	1665	1230
	BA1.81/11.88 (Min)	—	14	1⅝	11⅞	3	2½	6-16d	10-16d	2-10dx1½	265	4015	3705	4005	3435	2665	1495
	BA1.81/11.88 (Max)	✓	14	1⅝	11⅞	3	2½	6-16d	10-16d	8-10dx1½	1170	4715	4320	4500	3800	2665	1495
	LBV1.81/11.88	—	14	1⅝	11⅞	3	2½	6-16d	4-16d	2-10dx1½	265	2910	2885	3190	2590	2060	1495
	WP11	✓	12	1⅝	11⅞	3½	2⅞	2-16d	—	2-10dx1½	—	3635	3320	3635	3255	2600	2030
	WPU1.81/11.88	✓	12	1⅝	11⅞	4	2⅞	3-16d	4-16d	6-10dx1½	1095	4700	4880	3650	4165	4165	—
1¾ x 14	ITS1.81/14	—	18	1⅝	13⅞	2	1⅞	4-10d	2-10d	—	105	1550	1365	1780	1520	1150	1085
	MIT1.81/14	—	16	1⅝	14	2½	2⅞	4-16d	4-16d	2-10dx1½	215	2550	2140	2115	2305	1665	1230
	BA1.81/14 (Min.)	—	14	1⅝	14	3	2½	6-16d	10-16d	2-10dx1½	265	4015	3705	4005	3435	2665	1495
	BA1.81/14 (Max.)	✓	14	1⅝	14	3	2½	6-16d	10-16d	8-10dx1½	1170	4715	4320	4500	3800	2665	1495
	LBV1.81/14	—	14	1⅝	14	3	2½	6-16d	4-16d	2-10dx1½	265	2910	2885	3190	2590	2060	1495
	WP14	✓	12	1⅝	14	3½	2⅞	2-16d	—	2-10dx1½	—	3635	3320	3635	3255	2600	2030

- Loads may not be increased for duration of load.
- Uplift loads are based on DF/SP lumber and have been increased for wind or earthquake loading with no further increase allowed. Reduce where other loads govern. For SPF/HF use 0.86 x DF/SP uplift load.
- When I-joist is used as header, all nails must be 10dx1½ and allowable loads assume flanges that are at least 1½" thick made of Douglas Fir, LVL or LSL. For other flange thicknesses, apply load adjustment factors found in the table below.
- Hangers sorted in order of recommended selection for best overall performance and installation value.
- Other nail schedules and loads are listed on pages 121-123.
- See pages 119-122 for Code reference numbers.
- Web stiffeners are required where noted and when supporting double I-joists with flanges less than 1⅝" thick in hangers that are 14 gauge and thinner.
- For 2¼"x22" and 24" joist sizes, refer to technical bulletin T-BSERIES.
- NAILS:** 16d = 0.162" dia. x 3⅞" long, 10d = 0.148" dia. x 3" long, 10dx1½ = 0.148" dia. x 1½" long. See pages 22-23 for other nail sizes and information.

Flange Material or Thickness	Hanger Series				
	ITS	MIT	LBV	WP	BA
1½" to 1¾"	0.75	0.75	0.75	0.75	0.75
1⅝" to 1⅞"	0.85	0.85	0.85	0.85	0.85
SPF	0.86	0.72	0.90	1.00	1.00

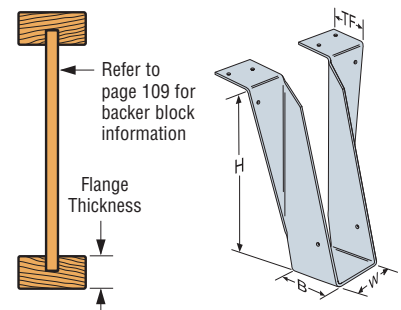

Parallam® is a registered trademark of Weyerhaeuser.

TOP FLANGE HANGERS – I-JOISTS & SCL

DON'T FEEL LIKE SIFTING THROUGH THIS TABLE?

Visit www.strongtie.com/software to learn more about our new Joist Hanger Selector software.

Actual Joist Size	Model No.	Web ⁷ Stiff Req ^d	Ga	Dimensions				Fasteners ⁵			Allowable Loads Header Type ^{1,2,6}						
				W	H	B	TF	Solid Header		Joist	Uplift (160)	LVL	PSL	LSL	DF/SP	SPF/HF	DF/SCL I-Joist ³
								Top	Face								
1 3/4 x 16	ITS1.81/16	—	18	1 1/2	15 1/4	2	1 1/2	4-10d	2-10d	—	105	1550	1365	1780	1520	1150	1085
	MIT1.81/16	—	16	1 3/4	16	2 1/2	2 3/4	4-16d	4-16d	2-10dx1 1/2	215	2550	2140	2115	2305	1665	1230
	LBV1.81/16	—	14	1 3/4	16	3	2 1/2	6-16d	4-16d	2-10dx1 1/2	265	2910	2885	3190	2590	2060	1495
	B1.81/16	✓	12	1 3/4	16	3	2 1/2	6-16d	8-16d	6-10dx1 1/2	990	4135	3355	4500	3640	2650	—
	WP16	✓	12	1 3/4	16	3 1/2	2 3/4	2-16d	—	2-10dx1 1/2	—	3635	3320	3635	3255	2600	2030
2 x 9 1/2	ITS2.06/9.5	—	18	2 1/2	9 1/4	2	1 1/2	4-10d	2-10d	—	105	1550	1365	1780	1520	1150	1085
	LBV2.06/9.5	—	14	2 1/2	9 1/2	2 1/2	2 1/2	6-16d	4-16d	2-10dx1 1/2	265	2910	2885	3190	2590	2060	1495
2 x 11 1/8	ITS2.06/11.88	—	18	2 1/2	11 3/8	2	1 1/2	4-10d	2-10d	—	105	1550	1365	1780	1520	1150	1085
	LBV2.06/11.88	—	14	2 1/2	11 7/8	2 1/2	2 1/2	6-16d	4-16d	2-10dx1 1/2	265	2910	2885	3190	2590	2060	1495
2 x 14	ITS2.06/14	—	18	2 1/2	13 1/4	2	1 1/2	4-10d	2-10d	—	105	1550	1365	1780	1520	1150	1085
	LBV2.06/14	—	14	2 1/2	14	2 1/2	2 1/2	6-16d	4-16d	2-10dx1 1/2	265	2910	2885	3190	2590	2060	1495
2 x 16	ITS2.06/16	—	18	2 1/2	15 1/4	2	1 1/2	4-10d	2-10d	—	105	1550	1365	1780	1520	1150	1085
	LBV2.06/16	—	14	2 1/2	16	2 1/2	2 1/2	6-16d	4-16d	2-10dx1 1/2	265	2910	2885	3190	2590	2060	1495
2 1/2 x 9 1/2	ITS2.06/9.5	—	18	2 1/2	9 1/4	2	1 1/2	4-10d	2-10d	—	105	1550	1365	1780	1520	1150	1085
	LBV2.1/9.5	—	14	2 1/2	9 1/2	2 1/2	2 1/2	6-16d	4-16d	2-10dx1 1/2	265	2910	2885	3190	2590	2060	1495
2 1/2 x 11 1/8	ITS2.06/11.88	—	18	2 1/2	11 3/8	2	1 1/2	4-10d	2-10d	—	105	1550	1365	1780	1520	1150	1085
	LBV2.1/11.88	—	14	2 1/2	11 7/8	2 1/2	2 1/2	6-16d	4-16d	2-10dx1 1/2	265	2910	2885	3190	2590	2060	1495
2 1/2 x 14	ITS2.06/14	—	18	2 1/2	13 1/4	2	1 1/2	4-10d	2-10d	—	105	1550	1365	1780	1520	1150	1085
	LBV2.1/14	—	14	2 1/2	14	2 1/2	2 1/2	6-16d	4-16d	2-10dx1 1/2	265	2910	2885	3190	2590	2060	1495
2 1/2 x 16	ITS2.06/16	—	18	2 1/2	15 1/4	2	1 1/2	4-10d	2-10d	—	105	1550	1365	1780	1520	1150	1085
	LBV2.1/16	—	14	2 1/2	16	2 1/2	2 1/2	6-16d	4-16d	2-10dx1 1/2	265	2910	2885	3190	2590	2060	1495
2 1/4 x 9 1/2 to 20 ⁸	2 1/4" wide joists use the same hangers as 2 5/8" wide joists with the following load adjustments to the table loads: ITS download is the lesser of the table load or 1400 lbs. ITS uplift is 85 lbs. MIT and HIT downloads are the lesser of the table load or 2140 lbs.																
2 5/8 x 9 1/2	ITS2.37/9.5	—	18	2 1/2	9 1/4	2	1 1/2	4-10d	2-10d	—	105	1550	1365	1780	1520	1150	1085
	LBV2.37/9.5	—	14	2 1/2	9 1/2	2 1/2	2 1/2	6-16d	4-16d	2-10dx1 1/2	265	2910	2885	3190	2590	2060	1495
2 5/8 x 11 1/8	ITS2.37/11.88	—	18	2 1/2	11 3/8	2	1 1/2	4-10d	2-10d	—	105	1550	1365	1780	1520	1150	1085
	MIT3511.88	—	16	2 3/8	11 7/8	2 1/2	2 3/4	4-16d	4-16d	2-10dx1 1/2	215	2550	2140	2115	2305	1665	1230
	LBV2.37/11.88	—	14	2 3/8	11 7/8	2 1/2	2 1/2	6-16d	4-16d	2-10dx1 1/2	265	2910	2885	3190	2590	2060	1495
	W3511.88	✓	12	2 5/8	11 7/8	2 1/2	2 1/2	2-16d	—	2-10dx1 1/2	—	2335	1950	2335	1765	1435	—
2 5/8 x 14	ITS2.37/14	—	18	2 1/2	13 1/4	2	1 1/2	4-10d	2-10d	—	105	1550	1365	1780	1520	1150	1085
	MIT3514	—	16	2 3/8	14	2 1/2	2 3/4	4-16d	4-16d	2-10dx1 1/2	215	2550	2140	2115	2305	1665	1230
	LBV2.37/14	—	14	2 3/8	14	2 1/2	2 1/2	6-16d	4-16d	2-10dx1 1/2	265	2910	2885	3190	2590	2060	1495
	WP3514	✓	12	2 5/8	14	2 1/2	2 3/4	2-16d	—	2-10dx1 1/2	—	3635	3320	3635	3255	2600	2030
2 5/8 x 16	ITS2.37/16	—	18	2 1/2	15 1/4	2	1 1/2	4-10d	2-10d	—	105	1550	1365	1780	1520	1150	1085
	MIT3516	—	16	2 3/8	16	2 1/2	2 3/4	4-16d	4-16d	2-10dx1 1/2	215	2550	2140	2115	2305	1665	1230
	LBV2.37/16	—	14	2 3/8	16	2 1/2	2 1/2	6-16d	4-16d	2-10dx1 1/2	265	2910	2885	3190	2590	2060	1495
	WP3516	✓	12	2 5/8	16	2 1/2	2 3/4	2-16d	—	2-10dx1 1/2	—	3635	3320	3635	3255	2600	2030
2 5/8 x 18	MIT3518	—	16	2 3/8	18	2 1/2	2 3/4	4-16d	4-16d	2-10dx1 1/2	215	2550	2140	2115	2305	1665	1230
	LBV2.37/18	—	14	2 3/8	18	2 1/2	2 1/2	6-16d	4-16d	2-10dx1 1/2	265	2910	2885	3190	2590	2060	1495
	WP3518	✓	12	2 5/8	18	2 1/2	2 3/4	2-16d	—	2-10dx1 1/2	—	3635	3320	3635	3255	2600	2030
2 5/8 x 20	MIT3520	—	16	2 3/8	20	2 1/2	2 3/4	4-16d	4-16d	2-10dx1 1/2	215	2550	2140	2115	2305	1665	1230
	LBV2.37/20	—	14	2 3/8	20	2 1/2	2 1/2	6-16d	4-16d	2-10dx1 1/2	265	2910	2885	3190	2590	2060	1495
	WP3520	✓	12	2 5/8	20	2 1/2	2 3/4	2-16d	—	2-10dx1 1/2	—	3635	3320	3635	3255	2600	2030
2 1/2 x 9 1/2 to 16	2 1/2" wide joists use the same hangers as 2 1/2" wide joists with the following load adjustments to the table loads: ITS download is same as table but not to exceed 1400 lbs. ITS uplift is 85 lbs. MIT download is same as table but not to exceed 2140 lbs.																
2 1/2 x 9 1/4	ITS2.56/9.25	—	18	2 1/2	9 1/4	2	1 1/2	4-10d	2-10d	—	105	1550	1365	1780	1520	1150	1085
	LBV2.56/9.25	—	14	2 1/2	9 1/4	2 1/2	2 1/2	6-16d	4-16d	2-10dx1 1/2	265	2910	2885	3190	2590	2060	1495
	WI39.25	✓	12	2 1/2	9 1/4	2	2 1/2	2-16d	—	2-10dx1 1/2	—	2335	1950	2335	1765	1435	—
2 1/2 - 2 5/8 x 9 1/2	ITS2.56/9.5	—	18	2 1/2	9 1/4	2	1 1/2	4-10d	2-10d	—	105	1550	1365	1780	1520	1150	1085
	BA2.56/9.5 (Min.)	—	14	2 1/2	9 1/2	3	2 1/2	6-16d	10-16d	2-10dx1 1/2	265	4015	3705	4005	3435	2665	1495
	BA2.56/9.5 (Max.)	✓	14	2 1/2	9 1/2	3	2 1/2	6-16d	10-16d	8-10dx1 1/2	1170	4715	4320	4500	3800	2665	1495
	LBV2.56/9.5	—	14	2 1/2	9 1/2	2 1/2	2 1/2	6-16d	4-16d	2-10dx1 1/2	265	2910	2885	3190	2590	2060	1495
	WI39.5	✓	12	2 1/2	9 1/2	2	2 1/2	2-16d	—	2-10dx1 1/2	—	2335	1950	2335	1765	1435	—

See footnotes on page 124.

TOP FLANGE HANGERS – I-JOISTS & SCL

Engineered Wood & Structural Composite Lumber Connectors

Actual Joist Size	Model No.	Web/ Stiff Req'd	Ga	Dimensions				Fasteners ⁵			Allowable Loads Header Type ^{1,2,6}						
				W	H	B	TF	Solid Header		Joist	Uplift (160)	LVL	PSL	LSL	DF/SP	SPF/ HF	DF/SCL I-Joist ³
								Top	Face								
2½ x 11¼	ITS2.56/11.25	—	18	2½	11¼	2	1⅞	4-10d	2-10d	—	105	1550	1365	1780	1520	1150	1085
	LBV2.56/11.25	—	14	2⅞	11¼	2½	2½	6-16d	4-16d	2-10dx1½	265	2910	2885	3190	2590	2060	1495
	WI311.25	✓	12	2⅞	11¼	2	2½	2-16d	—	2-10dx1½	—	2335	1950	2335	1765	1435	—
2½ - 2⅞ x 11⅝	ITS2.56/11.88	—	18	2½	11⅝	2	1⅞	4-10d	2-10d	—	105	1550	1365	1780	1520	1150	1085
	MIT311.88	—	16	2⅞	11⅝	2½	2⅞	4-16d	4-16d	2-10dx1½	215	2550	2140	2115	2305	1665	1230
	BA2.56/11.88 (Min)	—	14	2⅞	11⅝	3	2½	6-16d	10-16d	2-10dx1½	265	4015	3705	4005	3435	2665	1495
	BA2.56/11.88 (Max)	✓	14	2⅞	11⅝	3	2½	6-16d	10-16d	8-10dx1½	1170	4715	4320	4500	3800	2665	1495
	LBV2.56/11.88	—	14	2⅞	11⅝	2½	2½	6-16d	4-16d	2-10dx1½	265	2910	2885	3190	2590	2060	1495
	WPI311.88	✓	12	2⅞	11⅝	2½	2⅞	2-16d	—	2-10dx1½	—	3635	3220	3695	3255	2600	2030
2½ - 2⅞ x 14	ITS2.56/14	—	18	2½	13⅞	2	1⅞	4-10d	2-10d	—	105	1550	1365	1780	1520	1150	1085
	MIT314	—	16	2⅞	14	2½	2⅞	4-16d	4-16d	2-10dx1½	215	2550	2140	2115	2305	1665	1230
	BA2.56/14 (Min)	—	14	2⅞	14	3	2½	6-16d	10-16d	2-10dx1½	265	4015	3705	4005	3435	2665	1495
	BA2.56/14 (Max)	✓	14	2⅞	14	3	2½	6-16d	10-16d	8-10dx1½	1170	4715	4320	4500	3800	2665	1495
	LBV2.56/14	—	14	2⅞	14	2½	2½	6-16d	4-16d	2-10dx1½	265	2910	2885	3190	2590	2060	1495
	WPI314	✓	12	2⅞	14	2½	2⅞	2-16d	—	2-10dx1½	—	3635	3320	3635	3255	2600	2030
2½ - 2⅞ x 16	ITS2.56/16	—	18	2½	15⅞	2	1⅞	4-10d	2-10d	—	105	1550	1365	1780	1520	1150	1085
	MIT316	—	16	2⅞	16	2½	2⅞	4-16d	4-16d	2-10dx1½	215	2550	2140	2115	2305	1665	1230
	BA2.56/16 (Min)	—	14	2⅞	16	3	2½	6-16d	10-16d	2-10dx1½	265	4015	3705	4005	3435	2665	1495
	BA2.56/16 (Max)	✓	14	2⅞	16	3	2½	6-16d	10-16d	8-10dx1½	1170	4715	4320	4500	3800	2665	1495
	LBV2.56/16	—	14	2⅞	16	2½	2½	6-16d	4-16d	2-10dx1½	265	2910	2885	3190	2590	2060	1495
	WPI316	✓	12	2⅞	16	2½	2⅞	2-16d	—	2-10dx1½	—	3635	3320	3635	3255	2600	2030
2½ x 18	MIT318	—	16	2⅞	18	2½	2⅞	4-16d	4-16d	2-10dx1½	215	2550	2140	2115	2305	1665	1230
	HIT318	—	16	2⅞	18	3	2⅞	4-16d	6-16d	2-10dx1½	315	2550	2220	2500	2875	1950	—
	LBV2.56/18	—	14	2⅞	18	2½	2½	6-16d	4-16d	2-10dx1½	265	2910	2885	3190	2590	2060	1495
	WPI318	✓	12	2⅞	18	2½	2⅞	2-16d	—	2-10dx1½	—	3635	3320	3635	3255	2600	2030
2½ x 20	MIT320	—	16	2⅞	20	2½	2⅞	4-16d	4-16d	2-10dx1½	215	2550	2140	2115	2305	1665	1230
	HIT320	—	16	2⅞	20	3	2⅞	4-16d	6-16d	2-10dx1½	315	2550	2220	2500	2875	1950	—
	LBV2.56/20	—	14	2⅞	20	2½	2½	6-16d	4-16d	2-10dx1½	265	2910	2885	3190	2590	2060	1495
	WPI320	✓	12	2⅞	20	2½	2⅞	2-16d	—	2-10dx1½	—	3635	3320	3635	3255	2600	2030
2½ x 22	HIT322	✓	16	2⅞	22	3	2⅞	4-16d	6-16d	2-10dx1½	315	2550	2220	2500	2875	1950	—
	LBV2.56/22	—	14	2⅞	22	2½	2½	6-16d	4-16d	2-10dx1½	265	2910	2885	3190	2590	2060	1495
	WPI322	✓	12	2⅞	22	2½	2⅞	2-16d	—	2-10dx1½	—	3635	3320	3635	3255	2600	2030
	HWI322	✓	11	2⅞	22	4	2½	4-16d	—	4-10dx1½	—	5100	4000	4500	5285	3665	—
2½ x 24	HIT324	✓	16	2⅞	24	3	2⅞	4-16d	6-16d	2-10dx1½	315	2550	2220	2500	2875	1950	—
	LBV2.56/24	—	14	2⅞	24	2½	2½	6-16d	4-16d	2-10dx1½	265	2910	2885	3190	2590	2060	1495
	WPI324	✓	12	2⅞	24	2½	2⅞	2-16d	—	2-10dx1½	—	3635	3320	3635	3255	2600	2030
2½ x 26	LBV2.56/26	—	14	2⅞	26	2½	2½	6-16d	4-16d	2-10dx1½	265	2910	2885	3190	2590	2060	1495
	WPI326	✓	12	2⅞	26	2½	2⅞	2-16d	—	2-10dx1½	—	3635	3320	3635	3255	2600	2030
2½ x 28	LBV2.56/28	—	14	2⅞	28	2½	2½	6-16d	4-16d	2-10dx1½	265	2910	2885	3190	2590	2060	1495
	WPI328	✓	12	2⅞	28	2½	2⅞	2-16d	—	2-10dx1½	—	3635	3320	3635	3255	2600	2030
2½ x 30	LBV2.56/30	—	14	2⅞	30	2½	2½	6-16d	4-16d	2-10dx1½	265	2910	2885	3190	2590	2060	1495
	WPI330	✓	12	2⅞	30	2½	2⅞	2-16d	—	2-10dx1½	—	3635	3320	3635	3255	2600	2030
3 x 9¼	LBV3.12/9.25	—	14	3⅞	9¼	2½	2½	6-16d	4-16d	2-10dx1½	265	2910	2885	3190	2590	2060	1495
	WP29.25-2	✓	12	3⅞	9¼	2½	2⅞	2-16d	—	2-10dx1½	—	3635	3320	3635	3255	2600	2030
3 x 9½	LBV3.12/9.5	—	14	3⅞	9½	2½	2½	6-16d	4-16d	2-10dx1½	265	2910	2885	3190	2590	2060	1495
	WP29.5-2	✓	12	3⅞	9½	2½	2⅞	2-16d	—	2-10dx1½	—	3635	3320	3635	3255	2600	2030
3 x 11¼	LBV3.12/11.25	—	14	3⅞	11¼	2½	2½	6-16d	4-16d	2-10dx1½	265	2910	2885	3190	2590	2060	1495
	WP211.25-2	✓	12	3⅞	11¼	2½	2⅞	2-16d	—	2-10dx1½	—	3635	3320	3635	3255	2600	2030
3 x 11⅝	LBV3.12/11.88	—	14	3⅞	11⅝	2½	2½	6-16d	4-16d	2-10dx1½	265	2910	2885	3190	2590	2060	1495
	WP211.88-2	✓	12	3⅞	11⅝	2½	2⅞	2-16d	—	2-10dx1½	—	3635	3320	3635	3255	2600	2030

See footnotes on page 124.

TOP FLANGE HANGERS – I-JOISTS & SCL

Engineered Wood & Structural Composite Lumber Connectors

Actual Joist Size	Model No.	Web ⁷ Stiff Req'd	Ga	Dimensions				Fasteners ⁵			Allowable Loads Header Type ^{1,2,6}						
				W	H	B	TF	Solid Header		Joist	Uplift (160)	LVL	PSL	LSL	DF/SP	SPF/ HF	DF/SCL I-Joist ³
								Top	Face								
3 x 14	LBV3.12/14	—	14	3 3/8	14	2 1/2	2 1/2	6-16d	4-16d	2-10dx1 1/2	265	2910	2885	3190	2590	2060	1495
3 x 16	LBV3.12/16	—	14	3 3/8	16	2 1/2	2 1/2	6-16d	4-16d	2-10dx1 1/2	265	2910	2885	3190	2590	2060	1495
3 1/2 x 7 1/4	LBV3.56/7.25	—	14	3 3/8	7 1/4	2 1/2	2 1/2	6-16d	4-16d	2-10dx1 1/2	265	2910	2885	3190	2590	2060	1495
	WPU3.56/7.25	✓	12	3 3/8	7 1/4	3	2 5/16	3-16d	4-16d	6-10dx1 1/2	1095	4700	4880	3650	4165	4165	—
3 1/2 x 9 1/4	LBV3.56/9.25	—	14	3 3/8	9 1/4	2 1/2	2 1/2	6-16d	4-16d	2-10dx1 1/2	265	2910	2885	3190	2590	2060	1495
	HB3.56/9.25	✓	10	3 3/8	9 1/4	3 1/2	3	6-16d	16-16d	10-16d	2610	5815	5640	6395	5650	3820	—
	WPI49.25	✓	12	3 3/8	9 1/4	2 1/2	2 5/16	2-16d	—	2-10dx1 1/2	—	3635	3320	3635	3255	2600	2030
	HWI49.25	✓	11	3 3/8	9 1/4	2 1/2	2 1/2	4-16d	—	2-10d	—	5100	4000	4500	5285	3665	—
	HWU3.56/9.25	✓	10	3 3/8	9 1/4	3 1/4	2 1/2	4-16d	4-16d	6-10d	1135	6335	5500	5535	6335	5415	—
	GLTV3.56/9.25	✓	7	3 3/8	9 1/4	5	2 7/8	4-16d	6-16d	6-16d	1295	7500	7400	5750	7200	5145	—
	HGLTV3.56/9.25	✓	7	3 3/8	9 1/4	6	2 7/8	6-16d	12-16d	6-16d	1295	10500	9485	9000	8835	6770	—
3 1/2 x 9 1/2	ITS3.56/9.5	—	18	3 3/8	9 1/2	2	1 1/16	4-10d	2-10d	—	105	1550	1365	1780	1520	1150	1085
	MIT49.5	✓	16	3 3/8	9 1/2	2 1/2	2 5/16	4-16d	4-16d	2-10dx1 1/2	215	2550	2140	2115	2305	1665	1230
	BA3.56/9.5 (Min.)	—	14	3 3/8	9 1/2	3	2 1/2	6-16d	10-16d	2-10dx1 1/2	265	4015	3705	4005	3435	2665	1495
	BA3.56/9.5 (Max.)	✓	14	3 3/8	9 1/2	3	2 1/2	6-16d	10-16d	8-10dx1 1/2	1170	4715	4320	4500	3800	2665	1495
	LBV3.56/9.5	—	14	3 3/8	9 1/2	2 1/2	2 1/2	6-16d	4-16d	2-10dx1 1/2	265	2910	2885	3190	2590	2060	1495
	HB3.56/9.5	✓	10	3 3/8	9 1/2	3 1/2	3	6-16d	16-16d	10-16d	2610	5815	5640	6395	5650	3820	—
	WPI49.5	✓	12	3 3/8	9 1/2	2 1/2	2 5/16	2-16d	—	2-10dx1 1/2	—	3635	3320	3635	3255	2600	2030
	HUI49.5TF	✓	12	3 3/8	9 1/2	2 1/2	2 1/2	4-16d	12-16d	6-10d	1125	4550	4550	4550	4550	—	—
	HWI49.5	✓	11	3 3/8	9 1/2	2 1/2	2 1/2	4-16d	—	2-10d	—	5100	4000	4500	5285	3665	—
	HWU3.56/9.5	✓	10	3 3/8	9 1/2	3 1/4	2 1/2	4-16d	4-16d	6-10d	1160	6335	5500	5535	6335	5415	—
	GLTV3.59	✓	7	3 3/8	9 1/2	5	2 7/8	4-16d	6-16d	6-16d	1295	7500	7400	5750	7200	5145	—
	HGLTV3.59	✓	7	3 3/8	9 1/2	6	2 7/8	6-16d	12-16d	6-16d	1295	10500	9485	9000	8835	6770	—
3 1/2 x 11 1/4	LBV3.56/11.25	—	14	3 3/8	11 1/4	2 1/2	2 1/2	6-16d	4-16d	2-10dx1 1/2	265	2910	2885	3190	2590	2060	1495
	HB3.56/11.25	✓	10	3 3/8	11 1/4	3 1/2	3	6-16d	16-16d	10-16d	2610	5815	5640	6395	5650	3820	—
	WPI411.25	✓	12	3 3/8	11 1/4	2 1/2	2 5/16	2-16d	—	2-10dx1 1/2	—	3635	3320	3635	3255	2600	2030
	HWI411.25	✓	11	3 3/8	11 1/4	2 1/2	2 1/2	4-16d	—	2-10d	—	5100	4000	4500	5285	3665	—
	HWU3.56/11.25	✓	10	3 3/8	11 1/4	3 1/4	2 1/2	4-16d	4-16d	6-10d	1135	6335	5500	5535	6335	5415	—
	GLTV3.56/11.25	✓	7	3 3/8	11 1/4	5	2 7/8	4-16d	6-16d	6-16d	1295	7500	7400	5750	7200	5145	—
	HGLTV3.56/11.25	✓	7	3 3/8	11 1/4	6	2 7/8	6-16d	12-16d	6-16d	1295	10500	9485	9000	8835	6770	—
3 1/2 x 11 1/8	ITS3.56/11.88	—	18	3 3/8	11 3/8	2	1 1/16	4-10d	2-10d	—	105	1550	1365	1780	1520	1150	1085
	MIT411.88	✓	16	3 3/8	11 3/8	2 1/2	2 5/16	4-16d	4-16d	2-10dx1 1/2	215	2550	2140	2115	2305	1665	1230
	BA3.56/11.88 (Min)	—	14	3 3/8	11 3/8	3	2 1/2	6-16d	10-16d	2-10dx1 1/2	265	4015	3705	4005	3435	2665	1495
	BA3.56/11.88 (Max)	✓	14	3 3/8	11 3/8	3	2 1/2	6-16d	10-16d	8-10dx1 1/2	1170	4715	4320	4500	3800	2665	1495
	LBV3.56/11.88	—	14	3 3/8	11 3/8	2 1/2	2 1/2	6-16d	4-16d	2-10dx1 1/2	265	2910	2885	3190	2590	2060	1495
	B3.56/11.88	✓	12	3 3/8	11 3/8	2 1/2	2 1/2	6-16d	8-16d	6-16d	1010	4135	3355	4500	3800	2650	—
	HB3.56/11.88	✓	10	3 3/8	11 3/8	3 1/2	3	6-16d	16-16d	10-16d	2610	5815	5640	6395	5650	3820	—
	WPI411.88	✓	12	3 3/8	11 3/8	2 1/2	2 5/16	2-16d	—	2-10dx1 1/2	—	3635	3320	3635	3255	2600	2030
	HUI411.88TF	✓	12	3 3/8	11 3/8	2 1/2	2 1/2	4-16d	12-16d	6-10d	1125	4550	4550	4550	4550	—	—
	WPU3.56/11.88	✓	12	3 3/8	11 3/8	3	2 5/16	3-16d	4-16d	6-10dx1 1/2	1095	4700	4880	—	4165	4165	—
	HWI411.88	✓	11	3 3/8	11 3/8	2 1/2	2 1/2	4-16d	—	2-10d	—	5100	4000	4500	5285	3665	—
	HWU3.56/11.88	✓	10	3 3/8	11 3/8	3 1/4	2 1/2	4-16d	4-16d	6-10d	1160	6335	5500	5535	6335	5415	—
	GLTV3.511	✓	7	3 3/8	11 3/8	5	2 7/8	4-16d	6-16d	6-16d	1295	7500	7400	5750	7200	5145	—
	HGLTV3.511	✓	7	3 3/8	11 3/8	6	2 7/8	6-16d	12-16d	6-16d	1295	10500	9485	9000	8835	6770	—
3 1/2 x 12	LBV3.56/12	—	14	3 3/8	12	2 1/2	2 1/2	6-16d	4-16d	2-10dx1 1/2	265	2910	2885	3190	2590	2060	1495
	HB3.56/12	✓	10	3 3/8	12	3 1/2	3	6-16d	16-16d	10-16d	2610	5815	5640	6395	5650	3820	—
	WPI412	✓	12	3 3/8	12	2 1/2	2 5/16	2-16d	—	2-10dx1 1/2	—	3635	3320	3650	3255	2600	2030
	HWI412	✓	11	3 3/8	12	2 1/2	2 1/2	4-16d	—	2-10d	—	5100	4000	4500	5285	3665	—
	GLTV3.512	✓	7	3 3/8	12	5	2 7/8	4-16d	6-16d	6-16d	1295	7500	7400	5750	7200	5145	—
	HGLTV3.512	✓	7	3 3/8	12	6	2 7/8	6-16d	12-16d	6-16d	1295	10500	9485	9000	8835	6770	—

See footnotes on page 124.

TOP FLANGE HANGERS – I-JOISTS & SCL

Engineered Wood & Structural Composite Lumber Connectors

Actual Joist Size	Model No.	Web/ Stiff Req'd	Ga	Dimensions				Fasteners ⁵			Allowable Loads Header Type ^{1,2,6}						
				W	H	B	TF	Solid Header		Joist	Uplift (160)	LVL	PSL	LSL	DF/SP	SPF/ HF	DF/SCL I-Joist ³
								Top	Face								
3½ x 14	ITS3.56/14	—	18	3¾	13⅞	2	1⅞	4-10d	2-10d	—	105	1550	1365	1780	1520	1150	1085
	MIT414	✓	16	3¾	14	2½	2⅞	4-16d	4-16d	2-10dx1½	215	2550	2140	2115	2305	1665	1230
	BA3.56/14 (Min)	—	14	3¾	14	3	2½	6-16d	10-16d	2-10dx1½	265	4015	3705	4005	3435	2665	1495
	BA3.56/14 (Max)	✓	14	3¾	14	3	2½	6-16d	10-16d	8-10dx1½	1170	4715	4320	4500	3800	2665	1495
	LBV3.56/14	—	14	3¾	14	2½	2½	6-16d	4-16d	2-10dx1½	265	2910	2885	3190	2590	2060	1495
	B3.56/14	✓	12	3¾	14	2½	2½	6-16d	8-16d	6-16d	1010	4135	3355	4500	3800	2650	—
	HB3.56/14	✓	10	3¾	14	3½	3	6-16d	16-16d	10-16d	2610	5815	5640	6395	5650	3820	—
	WPI414	✓	12	3¾	14	2½	2⅞	2-16d	—	2-10dx1½	—	3635	3320	3650	3255	2600	2030
	HUI414TF	✓	12	3¾	14	2½	2½	4-16d	14-16d	8-10d	1500	4830	4830	4830	4830	—	—
	WPU3.56/14	✓	12	3¾	14	3	2⅞	3-16d	4-16d	6-10dx1½	1095	4700	4880	—	4165	4165	—
	HWI414	✓	11	3¾	14	2½	2½	4-16d	—	2-10d	—	5100	4000	4500	5285	3665	—
	HWU3.56/14	✓	10	3¾	14	¾	2½	4-16d	4-16d	6-10d	1135	6335	5500	5535	6335	5415	—
GLTV3.514	✓	7	3¾	14	5	2⅞	4-16d	6-16d	6-16d	1295	7500	7400	5750	7200	5145	—	
HGLTV3.514	✓	7	3¾	14	6	2⅞	6-16d	12-16d	6-16d	1295	10500	9485	9000	8835	6770	—	
3½ x 16	ITS3.56/16	—	18	3¾	15⅞	2	1⅞	4-10d	2-10d	—	105	1550	1365	1780	1520	1150	1085
	MIT416	✓	16	3¾	16	2½	2⅞	4-16d	4-16d	2-10dx1½	215	2550	2140	2115	2305	1665	1230
	BA3.56/16 (Min)	—	14	3¾	16	3	2½	6-16d	10-16d	2-10dx1½	265	4015	3705	4005	3435	2665	1495
	BA3.56/16 (Max)	✓	14	3¾	16	3	2½	6-16d	10-16d	8-10dx1½	1170	4715	4320	4500	3800	2665	1495
	LBV3.56/16	—	14	3¾	16	2½	2½	6-16d	4-16d	2-10dx1½	265	2910	2885	3190	2590	2060	1495
	B3.56/16	✓	12	3¾	16	2½	2½	6-16d	8-16d	6-16d	1010	4135	3355	4500	3800	2650	—
	HB3.56/16	✓	10	3¾	16	3½	3	6-16d	16-16d	10-16d	2610	5815	5640	6395	5650	3820	—
	WPI416	✓	12	3¾	16	2½	2⅞	2-16d	—	2-10dx1½	—	3635	3320	3650	3255	2600	2030
	WPU3.56/16	✓	12	3¾	16	3	2⅞	3-16d	4-16d	6-10dx1½	1095	4700	4880	—	4165	4165	—
	HWI416	✓	11	3¾	16	2½	2½	4-16d	—	2-10d	—	5100	4000	4500	5285	3665	—
	HWU3.56/16	✓	10	3¾	16	¾	2½	4-16d	4-16d	6-10d	1160	6335	5500	5535	6335	5415	—
	GLTV3.516	✓	7	3¾	16	5	2⅞	4-16d	6-16d	6-16d	1295	7500	7400	5750	7200	5145	—
HGLTV3.516	✓	7	3¾	16	6	2⅞	6-16d	12-16d	6-16d	1295	10500	9485	9000	8835	6770	—	
3½ x 18	MIT418	✓	16	3¾	18	2½	2⅞	4-16d	4-16d	2-10dx1½	215	2550	2140	2115	2305	1665	1230
	HIT418	—	16	3¾	18	3	2⅞	4-16d	6-16d	2-10dx1½	315	2550	2220	2500	2875	1950	—
	LBV3.56/18	—	14	3¾	18	2½	2½	6-16d	4-16d	2-10dx1½	265	2910	2885	3190	2590	2060	1495
	HB3.56/18	✓	10	3¾	18	3½	3	6-16d	16-16d	10-16d	2610	5815	5640	6395	5650	3820	—
	WPI418	✓	12	3¾	18	2½	2⅞	2-16d	—	2-10dx1½	—	3635	3320	3650	3255	2600	2030
	WPU3.56/18	✓	12	3¾	18	3	2⅞	3-16d	4-16d	6-10dx1½	1095	4700	4880	—	4165	4165	—
	HWI418	✓	11	3¾	18	2½	2½	4-16d	—	2-10d	—	5100	4000	4500	5285	3665	—
	HWU3.56/18	✓	10	3¾	18	¾	2½	4-16d	4-16d	6-10d	1160	6335	5500	5535	6335	5415	—
	GLTV3.518	✓	7	3¾	18	5	2⅞	4-16d	6-16d	6-16d	1295	7500	7400	5750	7200	5145	—
	HGLTV3.518	✓	7	3¾	18	6	2⅞	6-16d	12-16d	6-16d	1295	10500	9485	9000	8835	6770	—
3½ x 18¾	GLTV3.56/18.75	✓	7	3¾	18¾	5	2⅞	4-16d	6-16d	6-16d	1295	7500	7400	5750	7200	5145	—
	HGLTV3.56/18.75	✓	7	3¾	18¾	6	2⅞	6-16d	12-16d	6-16d	1295	10500	7800	9000	8835	6770	—
3½ x 20	MIT420	✓	16	3¾	20	2½	2⅞	4-16d	4-16d	2-10dx1½	215	2550	2140	2115	2305	1665	1230
	HIT420	—	16	3¾	20	3	2⅞	4-16d	6-16d	2-10dx1½	315	2550	2220	2500	2875	1950	—
	LBV3.56/20	—	14	3¾	20	2½	2½	6-16d	4-16d	2-10dx1½	265	2910	2885	3190	2590	2060	1495
	HB3.56/20	✓	10	3¾	20	3½	3	6-16d	16-16d	10-16d	2610	5815	5640	6395	5650	3820	—
	WPI420	✓	12	3¾	20	2½	2⅞	2-16d	—	2-10dx1½	—	3635	3320	3650	3255	2600	2030
	WPU3.56/20	✓	12	3¾	20	3	2⅞	3-16d	4-16d	6-10dx1½	390	4700	4880	—	4165	4165	—
	HWI420	✓	11	3¾	20	2½	2½	4-16d	—	2-10d	—	5100	4000	4500	5285	3665	—
	HWU3.56/20	✓	10	3¾	20	¾	2½	4-16d	4-16d	6-10d	965	6335	5500	5535	6335	5415	—
	GLTV3.520	✓	7	3¾	20	5	2⅞	4-16d	6-16d	6-16d	1295	7500	7400	5750	7200	5145	—
HGLTV3.520	✓	7	3¾	20	6	2⅞	6-16d	12-16d	6-16d	1295	10500	9485	9000	8835	6770	—	

See footnotes on page 124.

TOP FLANGE HANGERS – I-JOISTS & SCL

Engineered Wood & Structural Composite Lumber Connectors

Actual Joist Size	Model No.	Web ⁷ Stiff Req'd	Ga	Dimensions				Fasteners ⁵			Allowable Loads Header Type ^{1,2,6}						
				W	H	B	TF	Solid Header		Joist	Uplift (160)	LVL	PSL	LSL	DF/SP	SPF/HF	DF/SCL I-Joist ³
								Top	Face								
3½ x 22	HIT422	—	16	3¼	22	3	2¾	4-16d	6-16d	2-10dx1½	315	2550	2220	2500	2875	1950	—
	LBV3.56/22	—	14	3¼	22	2½	2½	6-16d	4-16d	2-10dx1½	265	2910	2885	3190	2590	2060	1495
	HB3.56/22	✓	10	3¼	22	3½	3	6-16d	16-16d	10-16d	2610	5815	5640	6395	5650	3820	—
	WPI422	✓	12	3¼	22	2½	2¾	2-16d	—	2-10dx1½	—	3635	3320	3650	3255	2600	2030
	WPU3.56/22	✓	12	3¼	22	3	2¾	3-16d	4-16d	6-10dx1½	390	4700	4880	—	4165	4165	—
HWI422	✓	11	3¼	22	2½	2½	4-16d	—	4-10d	—	5100	4000	4500	5285	3665	—	
3½ x 24	HIT424	—	16	3¼	24	3	2¾	4-16d	6-16d	2-10dx1½	315	2550	2220	2500	2875	1950	—
	LBV3.56/24	—	14	3¼	24	2½	2½	6-16d	4-16d	2-10dx1½	265	2910	2885	3190	2590	2060	1495
	HB3.56/24	✓	10	3¼	24	3½	3	6-16d	16-16d	10-16d	2610	5815	5640	6395	5650	3820	—
	WPI424	✓	12	3¼	24	2½	2¾	2-16d	—	2-10dx1½	—	3635	3320	3650	3255	2600	2030
	WPU3.56/24	✓	12	3¼	24	3	2¾	3-16d	4-16d	6-10dx1½	390	4700	4880	—	4165	4165	—
HWI424	✓	11	3¼	24	2½	2½	4-16d	—	4-10d	—	5100	4000	4500	5285	3665	—	
3½ x 26	LBV3.56/26	—	14	3¼	26	2½	2½	6-16d	4-16d	2-10dx1½	265	2910	2885	3190	2590	2060	1495
	HB3.56/26	✓	10	3¼	26	3½	3	6-16d	16-16d	10-16d	2610	5815	5640	6395	5650	3820	—
	WPI426	✓	12	3¼	26	2½	2¾	2-16d	—	2-10dx1½	—	3635	3320	3650	3255	2600	2030
	WPU3.56/26	✓	12	3¼	26	3	2¾	3-16d	4-16d	6-10dx1½	390	4700	4880	—	4165	4165	—
	HWI426	✓	11	3¼	26	2½	2½	4-16d	—	4-10d	—	5100	4000	4500	5285	3665	—
3½ x 28	LBV3.56/28	—	14	3¼	28	2½	2½	6-16d	4-16d	2-10dx1½	265	2910	2885	3190	2590	2060	1495
	HB3.56/28	✓	10	3¼	28	3½	3	6-16d	16-16d	10-16d	2610	5815	5640	6395	5650	3820	—
	WPI428	✓	12	3¼	28	2½	2¾	2-16d	—	2-10dx1½	—	3635	3320	3650	3255	2600	2030
	WPU3.56/28	✓	12	3¼	28	3	2¾	3-16d	4-16d	6-10dx1½	390	4700	4880	—	4165	4165	—
	HWI428	✓	11	3¼	28	2½	2½	4-16d	—	4-10d	—	5100	4000	4500	5285	3665	—
3½ x 30	LBV3.56/30	—	14	3¼	30	2½	2½	6-16d	4-16d	2-10dx1½	265	2910	2885	3190	2590	2060	1495
	HB3.56/30	✓	10	3¼	30	3½	3	6-16d	16-16d	10-16d	2610	5815	5640	6395	5650	3820	—
	WPI430	✓	12	3¼	30	2½	2¾	2-16d	—	2-10dx1½	—	3635	3320	3650	3255	2600	2030
	HWI430	✓	11	3¼	30	2½	2½	4-16d	—	4-10d	—	5100	4000	4500	5285	3665	—
	WPI432	✓	12	3¼	32	2½	2¾	2-16d	—	2-10dx1½	—	3635	3320	3650	3255	2600	2030
HWI432	✓	11	3¼	32	2½	2½	4-16d	—	4-10d	—	5100	4000	4500	5285	3665	—	
4 x 9½	MIT4.12/9.5	✓	16	4½	9½	2½	2¾	4-16d	4-16d	2-10dx1½	215	2550	2140	2115	2305	1665	1230
	LBV4.12/9.5	—	14	4½	9½	2½	2½	6-16d	4-16d	2-10dx1½	265	2910	2885	3190	2590	2060	1495
4 x 11½	MIT4.12/11.88	✓	16	4½	11½	2½	2¾	4-16d	4-16d	2-10dx1½	215	2550	2140	2115	2305	1665	1230
	LBV4.12/11.88	—	14	4½	11½	2½	2½	6-16d	4-16d	2-10dx1½	265	2910	2885	3190	2590	2060	1495
4 x 14	MIT4.12/14	✓	16	4½	14	2½	2¾	4-16d	4-16d	2-10dx1½	215	2550	2140	2115	2305	1665	1230
	LBV4.12/14	—	14	4½	14	2½	2½	6-16d	4-16d	2-10dx1½	265	2910	2885	3190	2590	2060	1495
4 x 16	LBV4.12/16	—	14	4½	16	2½	2½	6-16d	4-16d	2-10dx1½	265	2910	2885	3190	2590	2060	1495
	MIT4.28/9.5	— ⁷	16	4¾	9½	2½	2¾	4-16d	4-16d	2-10dx1½	215	2550	2140	2115	2305	1665	1230
4½ x 9½	LBV4.28/9.5	—	14	4¾	9½	2½	2½	6-16d	4-16d	2-10dx1½	265	2910	2885	3190	2590	2060	1495
	MIT4.28/11.88	— ⁷	16	4¾	11½	2½	2¾	4-16d	4-16d	2-10dx1½	215	2550	2140	2115	2305	1665	1230
4½ x 11½	LBV4.28/11.88	—	14	4¾	11½	2½	2½	6-16d	4-16d	2-10dx1½	265	2910	2885	3190	2590	2060	1495
	MIT4.28/14	— ⁷	16	4¾	14	2½	2¾	4-16d	4-16d	2-10dx1½	215	2550	2140	2115	2305	1665	1230
4½ x 14	LBV4.28/14	—	14	4¾	14	2½	2½	6-16d	4-16d	2-10dx1½	265	2910	2885	3190	2590	2060	1495
	LBV4.28/16	—	14	4¾	16	2½	2½	6-16d	4-16d	2-10dx1½	265	2910	2885	3190	2590	2060	1495
4½ x 9½ to 20	4½" wide joists use the same hangers as 4" wide joists with the following loads adjustments: MIT downloads are the lesser of the table load or 2140 lbs.																
4½ x 9½	MIT359.5-2	— ⁷	16	4¾	9½	2½	2¾	4-16d	4-16d	2-10dx1½	215	2550	2140	2115	2305	1665	1230
	LBV4.75/9.5	—	14	4¾	9½	2½	2½	6-16d	4-16d	2-10dx1½	265	2910	2885	3190	2590	2060	1495
	WP359.5-2	✓	12	4¾	9½	2½	2¾	3-16d	—	2-10d	—	3635	3320	3650	3255	2600	2030
4½ x 11½	MIT3511.88-2	— ⁷	16	4¾	11½	2½	2¾	4-16d	4-16d	2-10dx1½	215	2550	2140	2115	2305	1665	1230
	LBV4.75/11.88	—	14	4¾	11½	2½	2½	6-16d	4-16d	2-10dx1½	265	2910	2885	3190	2590	2060	1495
	WP3511.88-2	✓	12	4¾	11½	2½	2¾	3-16d	—	2-10dx1½	—	3635	3320	3650	3255	2600	2030
4½ x 14	MIT3514-2	— ⁷	16	4¾	14	2½	2¾	4-16d	4-16d	2-10dx1½	215	2550	2140	2115	2305	1665	1230
	LBV4.75/14	—	14	4¾	14	2½	2½	6-16d	4-16d	2-10dx1½	265	2910	2885	3190	2590	2060	1495
	WP3514-2	✓	12	4¾	14	2½	2¾	3-16d	—	2-10dx1½	—	3635	3320	3650	3255	2600	2030
4½ x 16	MIT4.75/16	— ⁷	16	4¾	16	2½	2¾	4-16d	4-16d	2-10dx1½	215	2550	2140	2115	2305	1665	1230
	LBV4.75/16	—	14	4¾	16	2½	2½	6-16d	4-16d	2-10dx1½	265	2910	2885	3190	2590	2060	1495
	WP3516-2	✓	12	4¾	16	2½	2¾	3-16d	—	2-10dx1½	—	3635	3320	3650	3255	2600	2030
4½ x 18	LBV4.75/18	—	14	4¾	18	2½	2½	6-16d	4-16d	2-10dx1½	265	2910	2885	3190	2590	2060	1495
	WP3518-2	✓	12	4¾	18	2½	2¾	3-16d	—	2-10dx1½	—	3635	3320	3650	3255	2600	2030
4½ x 20	LBV4.75/20	—	14	4¾	20	2½	2½	6-16d	4-16d	2-10dx1½	265	2910	2885	3190	2590	2060	1495
	WP3520-2	✓	12	4¾	20	2½	2¾	3-16d	—	2-10dx1½	—	3635	3320	3650	3255	2600	2030
5 x 9¼	LBV5.12/9.25	—	14	5½	9¼	2½	2½	6-16d	4-16d	2-10dx1½	265	2910	2885	3190	2590	2060	1495

See footnotes on page 124.

TOP FLANGE HANGERS – I-JOISTS & SCL

Engineered Wood & Structural Composite Lumber Connectors

Actual Joist Size	Model No.	Web/Stiff Req'd	Ga	Dimensions				Fasteners ⁵			Allowable Loads Header Type ^{1,2,6}						
				W	H	B	TF	Solid Header		Joist	Uplift (160)	LVL	PSL	LSL	DF/SP	SPF/HF	DF/SCL I-Joist ³
								Top	Face								
5 x 9½	MIT39.5-2	— ⁷	16	5½	9½	2½	2¾	4-16d	4-16d	2-10dx1½	215	2550	2140	2115	2305	1665	1230
	LBV5.12/9.5	—	14	5½	9½	2½	2¾	6-16d	4-16d	2-10dx1½	265	2910	2885	3190	2590	2060	1495
	WPI39.5-2	✓	12	5½	9½	2½	2¾	3-16d	—	2-10dx1½	—	3635	3320	3650	3255	2600	2030
5 x 11¼	LBV5.12/11.25	—	14	5½	11¼	2½	2¾	6-16d	4-16d	2-10dx1½	265	2910	2885	3190	2590	2060	1495
5 x 11½	MIT311.88-2	— ⁷	16	5½	11½	2½	2¾	4-16d	4-16d	2-10dx1½	215	2550	2140	2115	2305	1665	1230
	LBV5.12/11.88	—	14	5½	11½	2½	2¾	6-16d	4-16d	2-10dx1½	265	2910	2885	3190	2590	2060	1495
	WPI311.88-2	✓	12	5½	11½	2½	2¾	3-16d	—	2-10dx1½	—	3635	3320	3650	3255	2600	2030
5 x 14	MIT314-2	— ⁷	16	5½	14	2½	2¾	4-16d	4-16d	2-10dx1½	215	2550	2140	2115	2305	1665	1230
	LBV5.12/14	—	14	5½	14	2½	2¾	6-16d	4-16d	2-10dx1½	265	2910	2885	3190	2590	2060	1495
	WPI314-2	✓	12	5½	14	2½	2¾	3-16d	—	2-10dx1½	—	3635	3320	3650	3255	2600	2030
5 x 16	MIT5.12/16	— ⁷	16	5½	16	2½	2¾	4-16d	4-16d	2-10dx1½	215	2550	2140	2115	2305	1665	1230
	LBV5.12/16	—	14	5½	16	2½	2¾	6-16d	4-16d	2-10dx1½	265	2910	2885	3190	2590	2060	1495
	HB5.12/16	✓	10	5½	16	3½	3	6-16d	16-16d	10-16d	2610	5815	5640	6395	5650	3820	—
	WPI316-2	✓	12	5½	16	2½	2¾	3-16d	—	2-10dx1½	—	3635	3320	3650	3255	2600	2030
5 x 18	B5.12/18	✓	12	5½	18	2½	2¾	6-16d	8-16d	6-16d	1010	4135	3355	4500	3800	2650	—
	HB5.12/18	✓	10	5½	18	3½	3	6-16d	16-16d	10-16d	2610	5815	5640	6395	5650	3820	—
	WPI318-2	✓	12	5½	18	2½	2¾	3-16d	—	2-10dx1½	—	3635	3320	3650	3255	2600	2030
5 x 20	B5.12/20	✓	12	5½	20	2½	2¾	6-16d	8-16d	6-16d	1010	4135	3355	4500	3800	2650	—
	HB5.12/20	✓	10	5½	20	3½	3	6-16d	16-16d	10-16d	2610	5815	5640	6395	5650	3820	—
	WPI320-2	✓	12	5½	20	2½	2¾	3-16d	—	2-10dx1½	—	3635	3320	3650	3255	2600	2030
5 x 22	B5.12/22	✓	12	5½	22	2½	2¾	6-16d	8-16d	6-16d	1010	4135	3355	4500	3800	2650	—
	HB5.12/22	✓	10	5½	22	3½	3	6-16d	16-16d	10-16d	2610	5815	5640	6395	5650	3820	—
	WPI322-2	✓	12	5½	22	2½	2¾	3-16d	—	2-10dx1½	—	3635	3320	3650	3255	2600	2030
5 x 24	B5.12/24	✓	12	5½	24	2½	2¾	6-16d	8-16d	6-16d	1010	4135	3355	4500	3800	2650	—
	HB5.12/24	✓	10	5½	24	3½	3	6-16d	16-16d	10-16d	2610	5815	5640	6395	5650	3820	—
	WPI324-2	✓	12	5½	24	2½	2¾	3-16d	—	2-10dx1½	—	3635	3320	3650	3255	2600	2030
5 x 26	B5.12/26	✓	12	5½	26	2½	2¾	6-16d	8-16d	6-16d	1010	4135	3355	4500	3800	2650	—
	HB5.12/26	✓	10	5½	26	3½	3	6-16d	16-16d	10-16d	2610	5815	5640	6395	5650	3820	—
	WPI326-2	✓	12	5½	26	2½	2¾	3-16d	—	2-10dx1½	—	3635	3320	3650	3255	2600	2030
5 x 28	B5.12/28	✓	12	5½	28	2½	2¾	6-16d	8-16d	6-16d	1010	4135	3355	4500	3800	2650	—
	HB5.12/28	✓	10	5½	28	3½	3	6-16d	16-16d	10-16d	2610	5815	5640	6395	5650	3820	—
5 x 30	B5.12/30	✓	12	5½	30	2½	2¾	6-16d	8-16d	6-16d	1010	4135	3355	4500	3800	2650	—
	HB5.12/30	✓	10	5½	30	3½	3	6-16d	16-16d	10-16d	2610	5815	5640	6395	5650	3820	—
5¼ x 7¼	WPU5.50/7.25	✓	12	5½	7¼	3	2¾	3-16d	4-16d	6-10d	1095	4700	4880	—	4165	4165	—
5¼ x 9¼	HB5.50/9.25	✓	10	5½	9¼	3½	3	6-16d	16-16d	10-16d	2610	5815	5640	6395	5650	3820	—
	HWU5.50/9.25	✓	10	5½	9¼	3¼	2½	4-16d	4-16d	6-10d	1160	6000	5500	5535	6000	5415	—
	GLTV5.50/9.25	✓	7	5½	9¼	5	2¾	4-16d	6-16d	6-16d	1295	7500	7400	5750	7200	5145	—
5¼ x 9½	HB5.50/9.5	✓	10	5½	9½	3½	3	6-16d	16-16d	10-16d	2610	5815	5640	6395	5650	3820	—
	WP5.50/9.5	✓	12	5½	9½	2½	2¾	3-16d	—	2-10d	—	3635	3320	3650	3255	2600	2030
	HWU5.50/9.5	✓	10	5½	9½	3¼	2½	4-16d	4-16d	6-10d	1160	6000	5500	5535	6000	5415	—
	GLTV5.59	✓	7	5½	9½	5	2¾	4-16d	6-16d	6-16d	1295	7500	7400	5750	7200	5145	—
	HGLTV5.59	✓	7	5½	9½	6	2¾	6-16d	12-16d	6-16d	1295	10500	9485	9000	8835	6770	—
5¼ x 11¼	HB5.50/11.25	✓	10	5½	11¼	3½	3	6-16d	16-16d	10-16d	2610	5815	5640	6395	5650	3820	—
	HWU5.50/11.25	✓	10	5½	11¼	3¼	2½	4-16d	4-16d	6-10d	1160	6000	5500	5535	6000	5415	—
	GLTV5.50/11.25	✓	7	5½	11¼	5	2¾	4-16d	6-16d	6-16d	1295	7500	7400	5750	7200	5145	—
5¼ x 11½	HB5.50/11.88	✓	10	5½	11½	3½	3	6-16d	16-16d	10-16d	2610	5815	5640	6395	5650	3820	—
	WP5.50/11.88	✓	12	5½	11½	2½	2¾	3-16d	—	2-10d	—	3635	3320	3650	3255	2600	2030
	HWU5.50/11.88	✓	10	5½	11½	3¼	2½	4-16d	4-16d	6-10d	1160	6000	5500	5535	6000	5415	—
	GLTV5.511	✓	7	5½	11½	5	2¾	4-16d	6-16d	6-16d	1295	7500	7400	5750	7200	5145	—
	HGLTV5.511	✓	7	5½	11½	6	2¾	6-16d	12-16d	6-16d	1295	10500	9485	9000	8835	6770	—
5¼ x 12	HB5.50/12	✓	10	5½	12	3½	3	6-16d	16-16d	10-16d	2610	5815	5640	6395	5650	3820	—
	HWU5.50/12	✓	10	5½	12	3¼	2½	4-16d	4-16d	6-10d	1160	6000	5500	5535	6000	5415	—
	GLTV5.512	✓	7	5½	12	5	2¾	4-16d	6-16d	6-16d	1295	7500	7400	5750	7200	5145	—
	HGLTV5.512	✓	7	5½	12	6	2¾	6-16d	12-16d	6-16d	1295	10500	9485	9000	8835	6770	—
5¼ x 14	HB5.50/14	✓	10	5½	14	3½	3	6-16d	16-16d	10-16d	2610	5815	5640	6395	5650	3820	—
	HWU5.50/14	✓	10	5½	14	3¼	2½	4-16d	4-16d	6-10d	1160	6000	5500	5535	6000	5415	—
	GLTV5.514	✓	7	5½	14	5	2¾	4-16d	6-16d	6-16d	1295	7500	7400	5700	7200	5145	—
	HGLTV5.514	✓	7	5½	14	6	2¾	6-16d	12-16d	6-16d	1295	10500	9485	9000	8835	6770	—

See footnotes on page 124.

TOP FLANGE HANGERS – I-JOISTS & SCL

Engineered Wood & Structural Composite Lumber Connectors

Actual Joist Size	Model No.	Web ⁷ Stiff Req'd	Ga	Dimensions				Fasteners ⁵			Allowable Loads Header Type ^{1,2,6}						
				W	H	B	TF	Solid Header		Joist	Uplift (160)	LVL	PSL	LSL	DF/SP	SPF/HF	DF/SCL I-Joist ³
								Top	Face								
5¼ x 16	HB5.50/16	✓	10	5½	16	3½	3	6-16d	16-16d	10-16d	2610	5815	5640	6395	5650	3820	—
	HWU5.50/16	✓	10	5½	16	3¼	2½	4-16d	4-16d	6-10d	1160	6000	5500	5535	6000	5415	—
	GLTV5.516	✓	7	5⅝	16	5	2⅝	4-16d	6-16d	6-16d	1295	7500	7400	5750	7200	5145	—
	HGLTV5.516	✓	7	5⅝	16	6	2⅝	6-16d	12-16d	6-16d	1295	10500	9485	9000	8835	6770	—
5¼ x 18	HB5.50/18	✓	10	5½	18	3½	3	6-16d	16-16d	10-16d	2610	5815	5640	6395	5650	3820	—
	HWU5.50/18	✓	10	5½	18	3¼	2½	4-16d	4-16d	6-10d	1160	6000	5500	5535	6000	5415	—
	GLTV5.518	✓	7	5⅝	18	5	2⅝	4-16d	6-16d	6-16d	1295	7500	7400	5750	7200	5145	—
5¼ x 18¾	GLTV5.50/18.75	✓	7	5½	18¾	5	2⅝	4-16d	6-16d	6-16d	1295	7500	7400	5750	7200	5145	—
	HGLTV5.50/18.75	✓	7	5½	18¾	6	2⅝	6-16d	12-16d	6-16d	1295	10500	9485	9000	8835	6770	—
5¼ x 20	HB5.50/20	✓	10	5½	20	3½	3	6-16d	16-16d	10-16d	2610	5815	5640	6395	5650	3820	—
	HWU5.50/20	✓	10	5½	20	3¼	2½	4-16d	4-16d	6-10d	965	6000	5500	5535	6000	5415	—
	GLTV5.520	✓	7	5⅝	20	5	2⅝	4-16d	6-16d	6-16d	1295	7500	7400	5750	7200	5145	—
	HGLTV5.520	✓	7	5⅝	20	6	2⅝	6-16d	12-16d	6-16d	1295	10500	9485	9000	8835	6770	—
7 x 7¼	HWU7.12/7.25	✓	10	7⅞	7¼	3¼	2½	4-16d	4-16d	6-10d	1160	6000	5500	5535	6000	5415	—
7 x 9¼	HB7.12/9.25	✓	10	7⅞	9¼	3½	3	6-16d	16-16d	10-16d	2610	5815	5640	6395	5650	3820	—
	WPI49.25-2	✓	12	7⅞	9¼	2½	2⅝	3-16d	—	2-10dx1½	—	3635	3320	3650	3255	2600	2030
	HWU7.12/9.25	✓	10	7⅞	9¼	3¼	2½	4-16d	4-16d	6-10d	1160	6000	5500	5535	6000	5415	—
	GLTV49.25-2	✓	7	7⅞	9¼	5	2⅝	4-16d	6-16d	6-16d	1295	7500	7400	5750	7200	5145	—
7 x 9½	B7.12/9.5	✓	12	7⅞	9½	2½	2½	6-16d	8-16d	6-16d	1010	4135	3355	4500	3800	2650	—
	HB7.12/9.5	✓	10	7⅞	9½	3½	3	6-16d	16-16d	10-16d	2610	5815	5640	6395	5650	3820	—
	WPI49.5-2	✓	12	7⅞	9½	2½	2⅝	3-16d	—	2-10dx1½	—	3635	3320	3650	3255	2600	2030
	HWU7.12/9.5	✓	10	7⅞	9½	3¼	2½	4-16d	4-16d	6-10d	1160	6000	5500	5535	6000	5415	—
7 x 11¼	GLTV49.5-2	✓	7	7⅞	9½	5	2⅝	4-16d	6-16d	6-16d	1295	7500	7400	5750	7200	5145	—
	HB7.12/11.25	✓	10	7⅞	11¼	3½	3	6-16d	16-16d	10-16d	2610	5815	5640	6395	5650	3820	—
	WPI411.25-2	✓	12	7⅞	11¼	2½	2⅝	3-16d	—	2-10dx1½	—	3635	3320	3650	3255	2600	2030
	HWU7.12/11.25	✓	10	7⅞	11¼	3¼	2½	4-16d	4-16d	6-10d	1160	6000	5500	5535	6000	5415	—
	GLTV411.25-2	✓	7	7⅞	11¼	5	2⅝	4-16d	6-16d	6-16d	1295	7500	7400	5750	7200	5145	—
7 x 11⅝	HGLTV411.25-2	✓	7	7⅞	11¼	6	2⅝	6-16d	12-16d	6-16d	1295	10500	9485	9000	8835	6770	—
	B7.12/11.88	✓	12	7⅞	11⅝	2½	2½	6-16d	8-16d	6-16d	1010	4135	3355	4500	3800	2650	—
	HB7.12/11.88	✓	10	7⅞	11⅝	3½	3	6-16d	16-16d	10-16d	2610	5815	5640	6395	5650	3820	—
	WPI411.88-2	✓	12	7⅞	11⅝	2½	2⅝	3-16d	—	2-10dx1½	—	3635	3320	3650	3255	2600	2030
	HWU7.12/11.88	✓	10	7⅞	11⅝	3¼	2½	4-16d	4-16d	6-10d	1160	6000	5500	5535	6000	5415	—
	GLTV411.88-2	✓	7	7⅞	11⅝	5	2⅝	4-16d	6-16d	6-16d	1295	7500	7400	5750	7200	5145	—
7 x 14	HGLTV411.88-2	✓	7	7⅞	11⅝	6	2⅝	6-16d	12-16d	6-16d	1295	10500	9485	9000	8835	6770	—
	B7.12/14	✓	12	7⅞	14	2½	2½	6-16d	8-16d	6-16d	1010	4135	3355	4500	3800	2650	—
	HB7.12/14	✓	10	7⅞	14	3½	3	6-16d	16-16d	10-16d	2610	5815	5640	6395	5650	3820	—
	WPI414-2	✓	12	7⅞	14	2½	2⅝	3-16d	—	2-10dx1½	—	3635	3320	3650	3255	2600	2030
	HWU7.12/14	✓	10	7⅞	14	3¼	2½	4-16d	4-16d	6-10d	1160	6000	5500	5535	6000	5415	—
	GLTV414-2	✓	7	7⅞	14	5	2⅝	4-16d	6-16d	6-16d	1295	7500	7400	5750	7200	5145	—
7 x 16	HGLTV414-2	✓	7	7⅞	14	6	2⅝	6-16d	12-16d	6-16d	1295	10500	9485	9000	8835	6770	—
	B7.12/16	✓	12	7⅞	16	2½	2½	6-16d	8-16d	6-16d	1010	4135	3355	4500	3800	2650	—
	HB7.12/16	✓	10	7⅞	16	3½	3	6-16d	16-16d	10-16d	2610	5815	5640	6395	5650	3820	—
	WPI416-2	✓	12	7⅞	16	2½	2⅝	3-16d	—	2-10dx1½	—	3635	3320	3650	3255	2600	2030
	HWU7.12/16	✓	10	7⅞	16	3¼	2½	4-16d	4-16d	6-10d	1160	6000	5500	5535	6000	5415	—
	GLTV416-2	✓	7	7⅞	16	5	2⅝	4-16d	6-16d	6-16d	1295	7500	7400	5750	7200	5145	—
7 x 18	HGLTV416-2	✓	7	7⅞	16	6	2⅝	6-16d	12-16d	6-16d	1295	10500	9485	9000	8835	6770	—
	B7.12/18	✓	12	7⅞	18	2½	2½	6-16d	8-16d	6-16d	1010	4135	3355	4500	3800	2650	—
	HB7.12/18	✓	10	7⅞	18	3½	3	6-16d	16-16d	10-16d	2610	5815	5640	6395	5650	3820	—
	HWI418-2	✓	11	7⅞	18	2½	2½	4-16d	—	2-10d	—	5100	4000	4500	5285	3665	—
	HWU7.12/18	✓	10	7⅞	18	3¼	2½	4-16d	4-16d	6-10d	1160	6000	5500	5535	6000	5415	—
	GLTV418-2	✓	7	7⅞	18	5	2⅝	4-16d	6-16d	6-16d	1295	7500	7400	5750	7200	5145	—
7 x 18¾	HGLTV418-2	✓	7	7⅞	18	6	2⅝	6-16d	12-16d	6-16d	1295	10500	9485	9000	8835	6770	—
	GLTV418.75-2	✓	7	7⅞	18¾	5	2⅝	4-16d	6-16d	6-16d	1295	7500	7400	5750	7200	4260	—

See footnotes on page 124.

TOP FLANGE HANGERS – I-JOISTS & SCL

Engineered Wood & Structural Composite Lumber Connectors

Actual Joist Size	Model No.	Web/ Stiff Req'd	Ga	Dimensions				Fasteners ⁵			Allowable Loads Header Type ^{1,2,6}						
				W	H	B	TF	Solid Header		Joist	Uplift (160)	LVL	PSL	LSL	DF/SP	SPF/ HF	DF/SCL I-Joist ³
								Top	Face								
7 x 20	B7.12/20	✓	12	7½	20	2½	2½	6-16d	8-16d	6-16d	1010	4135	3355	4500	3800	2650	—
	HB7.12/20	✓	10	7½	20	3½	3	6-16d	16-16d	10-16d	2610	5815	5640	6395	5650	3820	—
	HWI420-2	✓	11	7½	20	2½	2½	4-16d	—	2-10d	—	5100	4000	4500	5285	3665	—
	HWU7.12/20	✓	10	7½	20	¾	2½	4-16d	4-16d	6-10d	965	6000	5500	5535	6000	5415	—
	GLTV420-2	✓	7	7½	20	5	2½	4-16d	6-16d	6-16d	1295	7500	7400	5700	7200	5145	—
	HGLTV420-2	✓	7	7½	20	6	2½	6-16d	12-16d	6-16d	1295	10500	9485	9000	8835	6770	—
7 x 22	B7.12/22	✓	12	7½	22	2½	2½	6-16d	8-16d	6-16d	1010	4135	3355	4500	3800	2650	—
	HB7.12/22	✓	10	7½	22	3½	3	6-16d	16-16d	10-16d	2610	5815	5640	6395	5650	3820	—
	HWI422-2	✓	11	7½	22	2½	2½	4-16d	—	4-10d	—	5100	4000	4500	5285	3665	—
	GLTV422-2	✓	7	7½	22	5	2½	4-16d	6-16d	6-16d	1295	7500	7400	5750	7200	5145	—
	HGLTV7.12/22	✓	7	7½	22	6	2½	6-16d	12-16d	6-16d	1295	10500	9485	9000	8835	6770	—
7 x 24	B7.12/24	✓	12	7½	24	2½	2½	6-16d	8-16d	6-16d	1010	4135	3355	4500	3800	2650	—
	HB7.12/24	✓	10	7½	24	3½	3	6-16d	16-16d	10-16d	2610	5815	5640	6395	5650	3820	—
	HWI424-2	✓	11	7½	24	2½	2½	4-16d	—	4-10d	—	5100	4000	4500	5285	3665	—
	GLTV424-2	✓	7	7½	24	5	2½	4-16d	6-16d	6-16d	1295	7500	7400	5750	7200	5145	—
	HGLTV7.12/24	✓	7	7½	24	6	2½	6-16d	12-16d	6-16d	1295	10500	9485	9000	8835	6770	—
7 x 26	B7.12/26	✓	12	7½	26	2½	2½	6-16d	8-16d	6-16d	1010	4135	3355	4500	3800	2650	—
	HB7.12/26	✓	10	7½	26	3½	3	6-16d	16-16d	10-16d	2610	5815	5640	6395	5650	3820	—
	HWI426-2	✓	11	7½	26	2½	2½	4-16d	—	6-10d	—	5100	4000	4500	5285	3665	—
	GLTV426-2	✓	7	7½	26	5	2½	4-16d	6-16d	6-16d	1295	7500	7400	5750	7200	5145	—
	HGLTV426-2	✓	7	7½	26	6	2½	6-16d	12-16d	6-16d	1295	10500	9485	9000	8835	6770	—
7 x 28	B7.12/28	✓	12	7½	28	2½	2½	6-16d	8-16d	6-16d	1010	4135	3355	4500	3800	2650	—
	HB7.12/28	✓	10	7½	28	3½	3	6-16d	16-16d	10-16d	2610	5815	5640	6395	5650	3820	—
	HWI428-2	✓	11	7½	28	2½	2½	4-16d	—	6-10d	—	5100	4000	4500	5285	3665	—
	GLTV428-2	✓	7	7½	28	5	2½	4-16d	6-16d	6-16d	1295	7500	7400	5750	7200	5145	—
	HGLTV428-2	✓	7	7½	28	6	2½	6-16d	12-16d	6-16d	1295	10500	9485	9000	8835	6770	—
7 x 30	HWI430-2	✓	11	7½	30	2½	2½	4-16d	—	6-10d	—	5100	4000	4500	5285	3665	—
	GLTV430-2	✓	7	7½	30	5	2½	4-16d	6-16d	6-16d	1295	7500	7400	5750	7200	5145	—
	HGLTV430-2	✓	7	7½	30	6	2½	6-16d	12-16d	6-16d	1295	10500	9485	9000	8835	6770	—
7 x 32	HWI432-2	✓	11	7½	32	2½	2½	4-16d	—	6-10d	—	5100	4000	4500	5285	3665	—
	GLTV432-2	✓	7	7½	32	5	2½	4-16d	6-16d	6-16d	1295	7500	7400	5750	7200	5145	—
	HGLTV432-2	✓	7	7½	32	6	2½	6-16d	12-16d	6-16d	1295	10500	9485	9000	8835	6770	—

See footnotes on page 124.

RC Ripper Clip

The Ripper Clip is designed to connect ripped 2x framing to the top of another wood joist.

MATERIAL: 20 gauge **FINISH:** Galvanized

INSTALLATION: • Use all specified fasteners. Refer to General Notes.

• Attach RC to ripper, then attach ripper/RC assembly to roof joist.

CODES: See page 12 for Code Reference Key Chart.

Model No.	W (in.)	Fasteners		Allowable Uplift Load (160)	F ₁	F ₂	Code Ref.
		Ripper	Joist				
RC1.56	1⅞	2-10dx1½	2-10dx1½	205	240	205	170
RC1.81	1⅜						
RC2.1	2⅞						

1. Allowable loads are for DFL ripper members.
2. Uplift loads have been increased for wind or earthquake loading with no other increase allowed. Reduce where other loads govern.
3. Designer to consider stability/blocking requirements for system, if necessary.
4. Spacing of RC per Designer.
5. **NAILS:** 10dx1½ = 0.148" dia. x 1½" long. See pages 22-23 for other nail sizes and information.

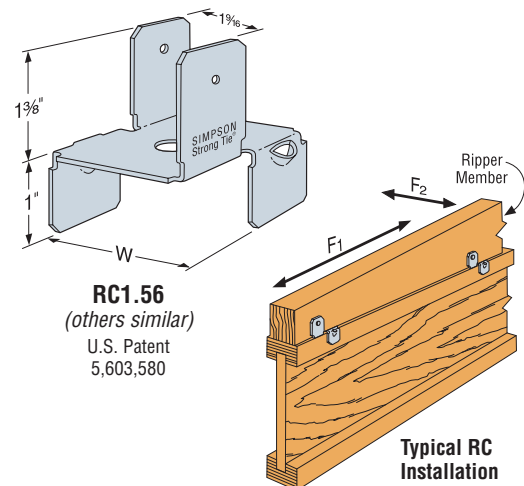

DU/DHU/DHUTF Drywall Hanger

The DU/DHU face-mount and the DHUTF top-mount hangers are designed to carry joist floor loads to a wood stud wall through two layers of 5/8" gypsum board (drywall). These hangers install after the drywall is in place. The hangers come in sizes that accommodate most joists used in multi-family construction including I-joists and trusses.

MATERIAL: DU—14 gauge; DHU and DHUTF—12 gauge

FINISH: Galvanized

INSTALLATION: • Use all specified fasteners. See General Notes.

- Simpson Strong-Tie® Strong-Drive® SDS Heavy-Duty Connector screws are provided with the hanger.
- Drywall is installed first.
- DU and DHU are mounted with top of hanger flush with top of wall and tight to the drywall.
- Wall top plates must be restrained to prevent rotation. Use an SSP stud plate tie connector at the back of each stud or provide equivalent restraint by another method as determined by Designer.
- Upper plate splices must occur at a stud location.

OPTIONS: • The DHU may be ordered with one flange concealed for widths at least 2 1/2" wide; specify which flange when ordering. Use 74% of the table downloads and 100% of table uplift loads.

CODES: See page 12 for Code Reference Key Chart.

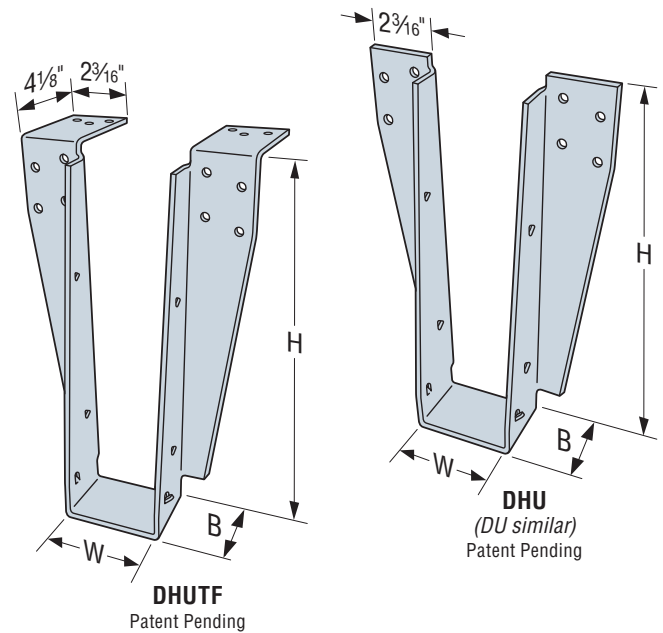

Fastener Table

Model	Gauge	B	Fasteners		
			Joist	Face	Top
DU	14	2	(2) 10d x 1 1/2"	(4) 1/4" x 3.5" SDS	—
DHU	12	2.5	(2) 10d x 1 1/2"	(8) 1/4" x 3.5" SDS	—
DHUTF	12	2.5	(2) 10d x 1 1/2"	(8) 1/4" x 3.5" SDS	(6) 10d x 1 1/2"

Allowable Loads

Model	Condition ¹	DF/SP Allowable Loads		SPF/HF Allowable Loads		Code Ref.
		Uplift (160) ^{3,4}	Down (100) ²	Uplift (160) ³	Down (100) ²	
DU	Over (1) layer 5/8" drywall	95	1110	170	880	160
	Over (2) layers 5/8" drywall	95	1110	170	880	
	Two-sided over (2) layers 5/8" drywall (minimum 2x6 wall)	95	1075	170	880	
	Over (1) layer 5/8" structural sheathing and (2) layers 5/8" drywall	95	1110	170	880	
DHU DHUTF	Over (1) layer 5/8" drywall	95	1250	170	1050	160
	Over (2) layers 5/8" drywall	95	1590 ⁵	170	1395 ⁵	
	Two-sided over (2) layers 5/8" drywall (minimum 2x6 wall)	95	1200	170	1005	
	Over (1) layer 5/8" structural sheathing and (2) layers 5/8" drywall	95	1975	170	1660	

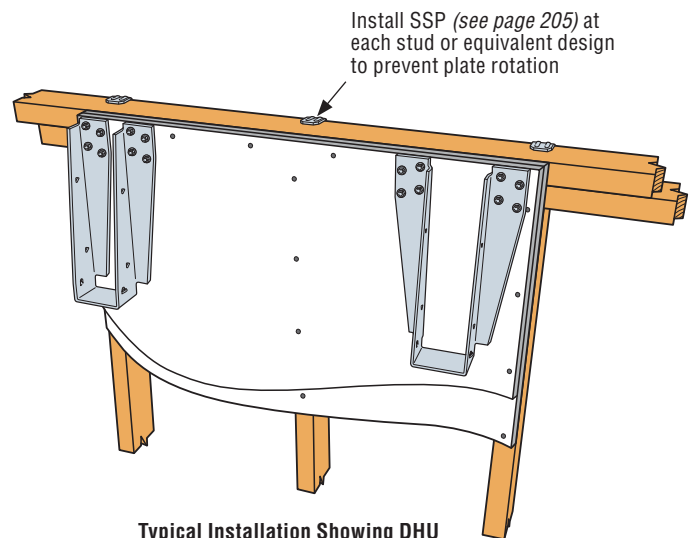

Typical Installation Showing DHU with Concealed Flange Option (at left) and a DHU Standard Installation

1. Loads assume 5/8" Type X drywall attached per IBC. Wall assembly must consist of minimum two 2x4 plate members with studs spaced not more than 16" o.c. For alternate solutions to mounting over single layer of drywall, refer to the technical bulletin T-C-TFWALL13 at www.strongtie.com.
2. Hangers spaced closer than 16" o.c. shall reduce capacity proportionately.
3. Triangle nail holes may be filled with (4) additional 10dx1 1/2" to achieve an Allowable Uplift Load of 750 lbs.
4. DF carried members with minimum 1 1/2" x 2 1/2" solid sawn chord dimension may increase Allowable Uplift Load to 170 lbs.
5. Allowable downloads may be increased to 1885 lbs. for DF/SP and 1585 lbs. for SPF/HF using the DHU3.56/24 or DHUTF3.56/24 models.

C-C-2015 © 2015 SIMPSON STRONG-TIE COMPANY INC. PRINTED 12/14 (This page has been updated since printing)

Engineered Wood & Structural Composite Lumber Connectors

DU/DHU/DHUTF Drywall Hanger

Engineered Wood & Structural Composite Lumber Connectors

Joist Size	Face Mount		Top Flange	Dimensions (in.)	
	DU Models	DHU Models	DHUTF Models	W	H
2x10	DU210	DHU210	DHU210TF	1 ¹ / ₁₆	9 ⁷ / ₁₆
2x12	DU212	DHU212	DHU212TF	1 ¹ / ₁₆	11 ¹ / ₁₆
1 ³ / ₄ x 9 ¹ / ₂	DU1.81/9.5	DHU1.81/9.5	DHU1.81/9.5TF	1 ¹³ / ₁₆	9 ⁷ / ₁₆
1 ³ / ₄ x 11 ⁵ / ₁₆	DU1.81/11.88	DHU1.81/11.88	DHU1.81/11.88TF	1 ¹³ / ₁₆	11 ¹³ / ₁₆
1 ³ / ₄ x 14	DU1.81/14	DHU1.81/14	DHU1.81/14TF	1 ¹³ / ₁₆	13 ¹⁵ / ₁₆
1 ³ / ₄ x 16	DU1.81/16	DHU1.81/16	DHU1.81/16TF	1 ¹³ / ₁₆	15 ¹⁵ / ₁₆
2 x 9 ¹ / ₂	DU2.1/9.5	DHU2.1/9.5	DHU2.1/9.5TF	2 ¹ / ₈	9 ⁷ / ₁₆
2 x 1 ¹ / ₈	DU2.1/11.88	DHU2.1/11.88	DHU2.1/11.88TF	2 ¹ / ₈	11 ¹³ / ₁₆
2 x 14	DU2.1/14	DHU2.1/14	DHU2.1/14TF	2 ¹ / ₈	13 ¹⁵ / ₁₆
2 x 16	DU2.1/16	DHU2.1/16	DHU2.1/16TF	2 ¹ / ₈	15 ¹⁵ / ₁₆
2 ¹ / ₁₆ x 9 ¹ / ₂	DU2.1/9.5	DHU2.1/9.5	DHU2.1/9.5TF	2 ¹ / ₈	9 ⁷ / ₁₆
2 ¹ / ₁₆ x 11 ⁵ / ₁₆	DU2.1/11.88	DHU2.1/11.88	DHU2.1/11.88TF	2 ¹ / ₈	11 ¹³ / ₁₆
2 ¹ / ₁₆ x 14	DU2.1/14	DHU2.1/14	DHU2.1/14TF	2 ¹ / ₈	13 ¹⁵ / ₁₆
2 ¹ / ₁₆ x 16	DU2.1/16	DHU2.1/16	DHU2.1/16TF	2 ¹ / ₈	15 ¹⁵ / ₁₆
2 ³ / ₁₆ x 9 ¹ / ₂	DU2.37/9.5	DHU2.37/9.5	DHU2.37/9.5TF	2 ³ / ₈	9 ⁷ / ₁₆
2 ³ / ₁₆ x 11 ⁵ / ₁₆	DU2.37/11.88	DHU2.37/11.88	DHU2.37/11.88TF	2 ³ / ₈	11 ¹³ / ₁₆
2 ³ / ₁₆ x 14	DU2.37/14	DHU2.37/14	DHU2.37/14TF	2 ³ / ₈	13 ¹⁵ / ₁₆
2 ³ / ₁₆ x 16	DU2.37/16	DHU2.37/16	DHU2.37/16TF	2 ³ / ₈	15 ¹⁵ / ₁₆
2 ⁵ / ₁₆ x 9 ¹ / ₂	—	DHU2.37/9.5	DHU2.37/9.5TF	2 ⁵ / ₁₆	9 ⁷ / ₁₆
2 ⁵ / ₁₆ x 11 ⁵ / ₁₆	—	DHU2.37/11.88	DHU2.37/11.88TF	2 ⁵ / ₁₆	11 ¹³ / ₁₆
2 ⁵ / ₁₆ x 14	—	DHU2.37/14	DHU2.37/14TF	2 ⁵ / ₁₆	13 ¹⁵ / ₁₆
2 ⁵ / ₁₆ x 16	—	DHU2.37/16	DHU2.37/16TF	2 ⁵ / ₁₆	15 ¹⁵ / ₁₆
2 ⁵ / ₁₆ x 18	—	DHU2.37/18	DHU2.37/18TF	2 ⁵ / ₁₆	17 ¹⁵ / ₁₆
2 ⁵ / ₁₆ x 20	—	DHU2.37/20	DHU2.37/20TF	2 ⁵ / ₁₆	19 ¹⁵ / ₁₆
2 ¹ / ₂ x 9 ¹ / ₂	—	DHU2.56/9.5	DHU2.56/9.5TF	2 ¹ / ₂	9 ⁷ / ₁₆
2 ¹ / ₂ x 11 ⁵ / ₁₆	—	DHU2.56/11.88	DHU2.56/11.88TF	2 ¹ / ₂	11 ¹³ / ₁₆
2 ¹ / ₂ x 14	—	DHU2.56/14	DHU2.56/14TF	2 ¹ / ₂	13 ¹⁵ / ₁₆
2 ¹ / ₂ x 16	—	DHU2.56/16	DHU2.56/16TF	2 ¹ / ₂	15 ¹⁵ / ₁₆
2 ¹ / ₂ x 18	—	DHU2.56/18	DHU2.56/18TF	2 ¹ / ₂	17 ¹⁵ / ₁₆
2 ¹ / ₂ x 20	—	DHU2.56/20	DHU2.56/20TF	2 ¹ / ₂	19 ¹⁵ / ₁₆
3 ¹ / ₂ x 9 ¹ / ₂	—	DHU3.56/9.5	DHU3.56/9.5TF	3 ¹ / ₂	9 ⁷ / ₁₆
3 ¹ / ₂ x 11 ⁵ / ₁₆	—	DHU3.56/11.88	DHU3.56/11.88TF	3 ¹ / ₂	11 ¹³ / ₁₆
3 ¹ / ₂ x 14	—	DHU3.56/14	DHU3.56/14TF	3 ¹ / ₂	13 ¹⁵ / ₁₆
3 ¹ / ₂ x 16	—	DHU3.56/16	DHU3.56/16TF	3 ¹ / ₂	15 ¹⁵ / ₁₆
3 ¹ / ₂ x 18	—	DHU3.56/18	DHU3.56/18TF	3 ¹ / ₂	17 ¹⁵ / ₁₆
3 ¹ / ₂ x 20	—	DHU3.56/20	DHU3.56/20TF	3 ¹ / ₂	19 ¹⁵ / ₁₆
3 ¹ / ₂ x 22	—	DHU3.56/22	DHU3.56/22TF	3 ¹ / ₂	21 ¹⁵ / ₁₆
3 ¹ / ₂ x 24	—	DHU3.56/24	DHU3.56/24TF	3 ¹ / ₂	23 ¹⁵ / ₁₆

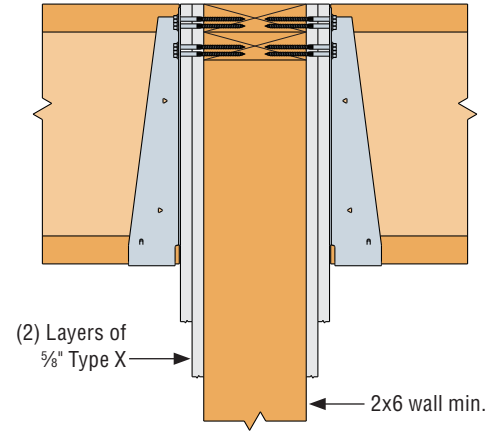

Two-Sided Installation Over (2) Layers of Drywall

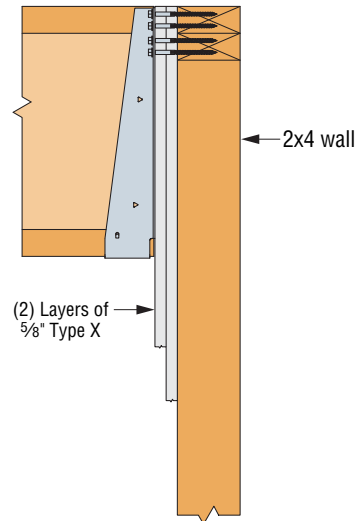

Typical Installation over (2) Layers of Drywall

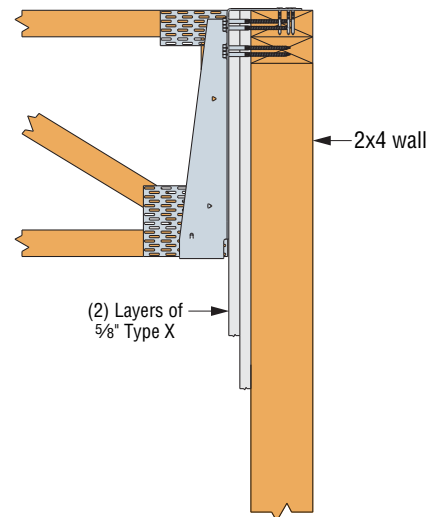

Typical Installation over (2) Layers of Drywall

HRC Hip Ridge Connectors

For complementary top plate connection, see page 138

The HRC series are field slopeable connectors that attach hips to ridge members or trusses. The HRC may be sloped to 45° with no reduction in loads.

MATERIAL: 16 gauge

FINISH: Galvanized

INSTALLATION:

- Use all specified fasteners. See General Notes.
- On end of ridge—use optional diamond holes to secure the HRC. Bend face flanges back flush with ridge, and complete nailing.
- On face of ridge—adjust to correct height and install nails.
- Double bevel-cut hip members to achieve full bearing capacity.
- The HRC may be sloped to 45° with no reduction in loads.

CODES: See page 12 for Code Reference Key Chart.

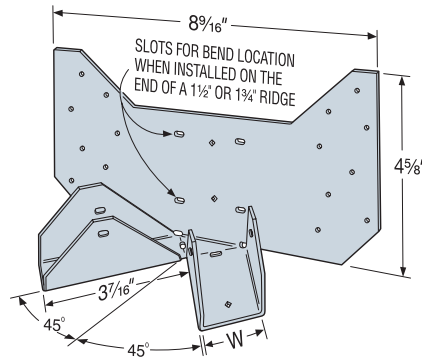

HRC1.81
U.S. Patent
5,380,116

Model No.	W	Member Size		Fasteners		DF/SP Allowable Loads				SPF/HF Allowable Loads				Code Ref.
		Hip	Ridge	Carrying Member	Each Hip	Uplift (160)	Floor (100)	Snow (115)	Roof (125)	Uplift (160)	Floor (100)	Snow (115)	Roof (125)	
HRC1.81	1 13/16	1 3/4	2x or 1 3/4" wide	16-10dx1 1/2	2-10dx1 1/2	290	720	830	900	250	625	720	780	I8, L15, F7

1. Allowable loads shown are for each hip. Total load carried by the connector is double this number.
2. Uplift loads include a 60% increase for wind or earthquake loading with no further increase allowed; reduce where other loads govern.
3. Roof loads are 125% of floor loads unless limited by other criteria.
4. **NAILS:** 10dx1 1/2 = 0.148" dia. x 1 1/2" long. See pages 22-23 for other nail sizes and information.

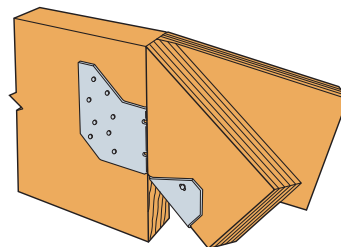

Typical HRC Installation on the End of a Ridge

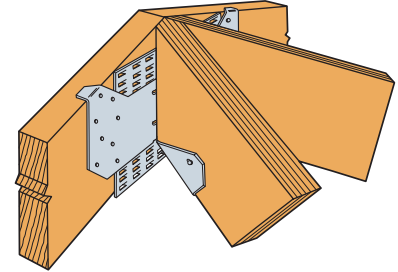

Optional HRC1.81 Installation

For additional SCL sizes, see page 98.

Engineered Wood & Structural Composite Lumber Connectors

SUR/SUL/HSUR/HSUL Skewed 45° Hangers for I-Joist and SCL



This product is preferable to similar connectors because of a) easier installation, b) higher loads, c) lower installed cost, or a combination of these features.

The SUR/L1.81, 2.06, 2.1, 2.37, 2.56 and HSUR/L series are 45° skewed hangers designed specifically to ease the installation of single and double I-joists. In addition to Positive Angle Nailing these hangers encapsulate the top flange of the I-joist, so no web stiffeners are required for standard installation.

The full range of 45° skewed hangers feature obround nail holes on the acute side allowing nails to be easily installed parallel to the joist. Installation is further simplified with no required bevel cuts.

MATERIAL: See table on page 136.

FINISH: Galvanized. Some products available in ZMAX® coating; see Corrosion Information, pages 13-15.

INSTALLATION: • Use all specified fasteners. See General Notes.

- Illustrations show left and right skews SUR/L (*SUR* = skewed right; *SUL* = skewed left).
- The joist end may be square cut or bevel cut.
- Fill all round and obround nail holes with specified fasteners to achieve table loads. Where noted, triangle holes in the joist flange may be filled for additional uplift capacity (see footnote on page 136).
- For I-joists with flanges less than 1 1/4", web stiffeners are required for all double joist hangers when using hangers that are 14 gauge and lighter.
- For installations to masonry or concrete, see page 175.

OPTIONS: • These hangers will accommodate a 40° to 50° skew.

- Available with the A₂ flange turned in on 2-2x and 4x models only (see illustration). For example, specify HSURC410, HSULC410, SURC210-2, or SULC210-2.

CODES: See page 12 for Code Reference Key Chart.

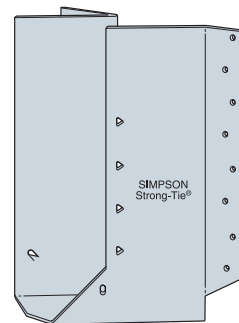

SUR2.56/11

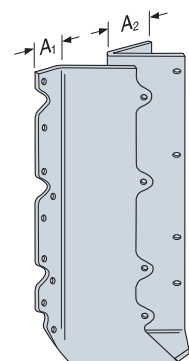

HSUR414

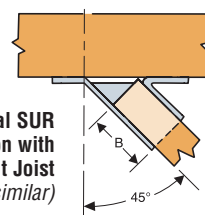

Typical SUR Installation with Square Cut Joist (HSUR similar)

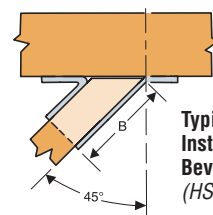

Typical SUL Installation with Bevel Cut Joist (HSUL similar)

SUR/SUL/HSUR/HSUL Skewed 45° Hangers for I-Joist and SCL

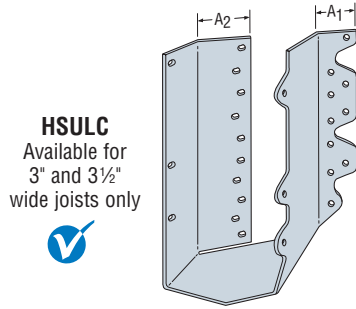

HSULC
Available for
3" and 3½"
wide joists only

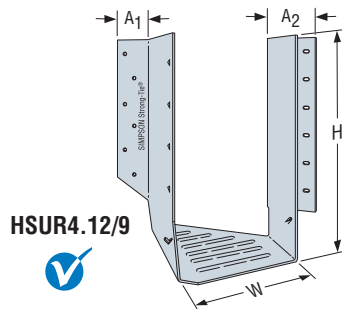

HSUR4.12/9

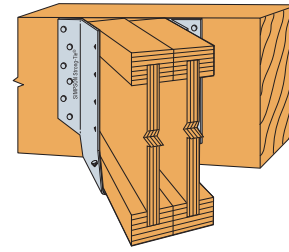

Typical HSUR4.12/9 Installation

These products are available with additional corrosion protection. Additional products on this page may also be available with this option, check with Simpson Strong-Tie for details.

These products are approved for installation with the Strong-Drive® SD Connector screw. See page 27 for more information.

Engineered Wood & Structural Composite Lumber Connectors

Actual Joist Size	Model No.	Web Stiff Req'd	Ga	Dimensions					Fasteners		Allowable Loads				Code Ref.				
				W	H	B	A1	A2	Face	Joist	DF/SP Species Header		SPF/HF Species Header						
											Uplift ² (160)	Floor (100)	Snow (115)	Roof (125)		Uplift ² (160)	Floor (100)	Snow (115)	Roof (125)
1½x9¼-12	SUR/L210	✓	16	1⅞	8	2	1⅞	1⅞	10-16d	10-10dx1½	1250	1440	1635	1760	1075	1240	1405	1515	I9, F6, L12, L17
1½x10-16	SUR/L214	✓	16	1⅞	10	2	1⅞	1⅞	12-16d	12-10dx1½	2165	1730	1960	2115	1860	1485	1685	1820	I9, L12
1¾x9¼-9½	SUR/L1.81/9	—	16	1⅞	9	3	1⅞	2⅞	12-16d	2-10dx1½	195	1730	1960	2030	170	1485	1685	1745	I9, L12
1¾x11¼-11⅞	SUR/L1.81/11	—	16	1⅞	11	3	1⅞	2⅞	16-16d	2-10dx1½	195	2305	2615	2730	170	1980	2245	2350	I9
1¾x14	SUR/L1.81/14	—	16	1⅞	13¼	3	1⅞	2⅞	20-16d	2-10dx1½	195	2500	2500	2500	170	2150	2150	2150	I9, L12
2x9½	SUR/L2.06/9	—	16	2⅞	9⅞	3⅞	1⅞	2⅞	14-16d	2-10dx1½	195	2015	2285	2465	170	1735	1965	2120	I9, F8, L12
2x11⅞	SUR/L2.06/11	—	16	2⅞	11¼	3⅞	1⅞	2⅞	16-16d	2-10dx1½	195	2305	2615	2665	170	1980	2245	2290	I9, L12
2x14	SUR/L2.06/14	—	16	2⅞	13¾	3⅞	1⅞	2⅞	18-16d	2-10dx1½	195	2590	2665	2665	170	2230	2290	2290	I9, L12
2x16	SUR/L2.06/14	✓	16	2⅞	13¾	3⅞	1⅞	2⅞	18-16d	2-10dx1½	195	2590	2665	2665	170	2230	2290	2290	I9, L12
2⅞x9½	SUR/L2.1/9	—	16	2⅞	9⅞	3⅞	1⅞	2⅞	14-16d	2-10dx1½	195	2015	2285	2465	170	1735	1965	2120	I9, L12
2⅞x11⅞	SUR/L2.1/11	—	16	2⅞	11⅞	3⅞	1⅞	2⅞	16-16d	2-10dx1½	195	2305	2615	2665	170	1980	2245	2290	I9, L12
2⅞x14	SUR/L2.1/14	—	16	2⅞	13¾	3⅞	1⅞	2⅞	18-16d	2-10dx1½	195	2590	2665	2665	170	2230	2290	2290	I9, L12
2⅞x16	SUR/L2.1/14	✓	16	2⅞	13¾	3⅞	1⅞	2⅞	18-16d	2-10dx1½	195	2590	2665	2665	170	2230	2290	2290	I9, L12
2¼-2⅞x9½	SUR/L2.37/9	—	16	2⅞	8⅞	3⅞	1⅞	2⅞	14-16d	2-10dx1½	195	2015	2285	2465	170	1735	1965	2120	I9, L12
2¼-2⅞x11⅞	SUR/L2.37/11	—	16	2⅞	11⅞	3⅞	1⅞	2⅞	16-16d	2-10dx1½	195	2305	2615	2665	170	1980	2245	2290	I9, L12
2¼-2⅞x14	SUR/L2.37/14	—	16	2⅞	13¾	3⅞	1⅞	2⅞	18-16d	2-10dx1½	195	2590	2665	2665	170	2230	2290	2290	I9, L12
2¼-2⅞x16	SUR/L2.37/14	✓	16	2⅞	13¾	3⅞	1⅞	2⅞	18-16d	2-10dx1½	195	2590	2665	2665	170	2230	2290	2290	I9, L12
2⅞x9½ (3x10,12)	SUR/L2.56/9	—	16	2⅞	8⅞	3⅞	1⅞	2⅞	14-16d	2-10dx1½	225	2015	2285	2465	195	1735	1965	2120	I9, L12, L17
2⅞-2⅞x11¼-11⅞	SUR/L2.56/11	—	16	2⅞	11⅞	3⅞	1⅞	2⅞	16-16d	2-10dx1½	225	2305	2615	2665	195	1980	2245	2290	I9, L12, L17
2⅞x14 (3x14)	SUR/L2.56/14	—	16	2⅞	13¾	3⅞	1⅞	2⅞	18-16d	2-10dx1½	225	2590	2665	2665	195	2230	2290	2290	I9, L12, L17
2⅞x16	SUR/L2.56/14	✓	16	2⅞	13¾	3⅞	1⅞	2⅞	18-16d	2-10dx1½	225	2590	2665	2665	195	2230	2290	2290	I9, L12, L17
3x9¼-14	SUR/L210-2	✓	16	3⅞	8⅞	2⅞	1⅞	2⅞	14-16d	6-16dx2½	1300	2015	2285	2465	1120	1735	1965	2120	I9, F6, L12, L17
	HSUR/L210-2	✓	14	3⅞	8⅞	2⅞	1⅞	2⅞	20-16d	6-16dx2½	1300	2975	3360	3610	1120	2565	2895	3110	I9, L12, L17
3x14-20	SUR/L214-2	✓	16	3⅞	12⅞	2⅞	1⅞	2⅞	18-16d	8-16dx2½	1765	2500	2500	2500	1520	2150	2150	2150	I9, F6, L12, L17
	HSUR/L214-2	✓	14	3⅞	12⅞	2⅞	1⅞	2⅞	26-16d	8-16dx2½	1795	3870	4365	4695	1550	3330	3760	4045	I9, F6, L12, L17
3½x9¼-14	SUR/L410	✓	16	3⅞	8⅞	2⅞	1	2⅞	14-16d	6-16d	1300	2015	2285	2465	1120	1735	1965	2120	I9, F8, L12
	HSUR/L410	✓	14	3⅞	8⅞	2⅞	1	2⅞	20-16d	6-16d	1300	2975	3360	3610	1120	2565	2895	3110	I9, F8, L12, L17
3½x14-20	SUR/L414	✓	16	3⅞	12⅞	2⅞	1	2⅞	18-16d	8-16d	1765	2500	2500	2500	1520	2150	2150	2150	I9, F8, L12
	HSUR/L414	✓	14	3⅞	12⅞	2⅞	1	2⅞	26-16d	8-16d	1795	3870	4365	4695	1550	3330	3760	4045	I9, F8, L12, L17
4x9½	HSUR/L4.12/9	—	14	4⅞	9	3	1⅞	2⅞	12-16d	2-10dx1½	165	1785	2015	2025	140	1540	1735	1740	I9, L12
4x11⅞	HSUR/L4.12/11	—	14	4⅞	11⅞	3	1⅞	2⅞	16-16d	2-10dx1½	165	2380	2685	2890	140	2050	2315	2490	I9, L12
4x14	HSUR/L4.12/14	—	14	4⅞	13¼	3	1⅞	2⅞	20-16d	2-10dx1½	165	2975	3330	3330	140	2565	2865	2865	I9, L12
4x16	HSUR/L4.12/16	—	14	4⅞	15¼	3	1⅞	2⅞	24-16d	2-10dx1½	165	3330	3330	3330	140	2865	2865	2865	I9, L12
4⅞x9½	HSUR/L4.28/9	—	14	4⅞	9	3	1⅞	2⅞	12-16d	2-10dx1½	165	1785	2015	2025	140	1540	1735	1740	I9, L12
4⅞x11⅞	HSUR/L4.28/11	—	14	4⅞	11⅞	3	1⅞	2⅞	16-16d	2-10dx1½	165	2380	2685	2890	140	2050	2315	2490	I9, L12
4⅞x14-16	HSUR/L4.28/11	✓	14	4⅞	11⅞	3	1⅞	2⅞	16-16d	2-10dx1½	165	2380	2685	2890	140	2050	2315	2490	I9, L12
4⅞x9½	HSUR/L4.75/9	—	14	4⅞	8⅞	2⅞	1⅞	2⅞	12-16d	2-10dx1½	165	1785	2015	2025	140	1540	1735	1740	I9, L12
4⅞x11⅞	HSUR/L4.75/11	—	14	4⅞	10⅞	2⅞	1⅞	2⅞	16-16d	2-10dx1½	165	2380	2685	2890	140	2050	2315	2490	I9, L12
4⅞x14	HSUR/L4.75/14	—	14	4⅞	13¼	2⅞	1⅞	2⅞	20-16d	2-10dx1½	165	2975	3330	3330	140	2565	2865	2865	I9, L12
4⅞x16	HSUR/L4.75/16	—	14	4⅞	15¼	2⅞	1⅞	2⅞	24-16d	2-10dx1½	165	3330	3330	3330	140	2865	2865	2865	I9, L12
5x9½	HSUR/L5.12/9	—	14	5⅞	9	2⅞	1⅞	2⅞	12-16d	2-10dx1½	165	1785	2015	2025	140	1540	1735	1740	I9, L12
5x11⅞	HSUR/L5.12/11	—	14	5⅞	11	2⅞	1⅞	2⅞	16-16d	2-10dx1½	165	2380	2685	2890	140	2050	2315	2490	I9, L12
5x14	HSUR/L5.12/14	—	14	5⅞	13¼	2⅞	1⅞	2⅞	20-16d	2-10dx1½	165	2975	3330	3330	140	2565	2865	2865	I9, L12
5x16	HSUR/L5.12/16	—	14	5⅞	15¼	2⅞	1⅞	2⅞	24-16d	2-10dx1½	165	3330	3330	3330	140	2865	2865	2865	I9, L12

1. Uplift loads have been increased for wind or earthquake loading with no further increase allowed; reduce where other loads govern.
 2. Triangle nail holes may be filled (requires web stiffeners) with 10dx1½ nails for additional uplift.
 • SUR/SUL 9- and 11-inch, SUR/SUL1.81/14 and all HSUR/HSUL models have additional holes, that when filled can resist 795 lbs. for Douglas Fir or Southern Pine or 685 lbs. for SPF/HF.
 • SUR/SUL 14-inch models have (6) additional holes, that when filled can resist 1190 lbs. for DF/SP and 1025 lbs. for SPF/HF.
 3. When the supported member is an I-joist with flanges less than 1⅞ inches thick, the allowable uplift shall not exceed 190 lbs. without web stiffeners.
 4. Allowable downloads are based on a joist bearing capacity of 750 psi.
 5. **NAILS:** 16d = 0.162" dia. x 3½" long, 10dx1½ = 0.148" dia. x 1½" long. See pages 22-23 for other nail sizes and information.

LSU/LSSU/LSSUI Light Slopeable/Skewable U Hangers for I-Joists and SCL



This product is preferable to similar connectors because of
a) easier installation, b) higher loads, c) lower installed cost,
or a combination of these features.

This series attaches joists or rafters to headers, sloped up or down, and skewed left or right, up to 45°.

MATERIAL: See table

FINISH: Galvanized

INSTALLATION: • Use all specified fasteners.

See General Notes.

- Attach the sloped joist at both ends so that the horizontal force developed by the slope is fully supported by the supporting members.
- Web stiffeners required for I-joist applications.
- To see an installation video on this product, visit www.strongtie.com.

CODES: See page 12 for Code Reference Key Chart.

LSU and LSSU INSTALLATION SEQUENCE

(For Skewed or Sloped/Skewed Applications)

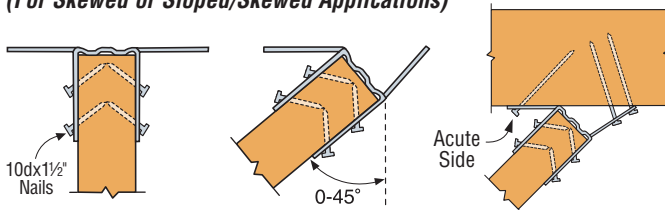

STEP 1
Nail hanger to slope-cut carried member, installing seat nail first. No bevel necessary. Install joist nails at 45° angle.

STEP 2
Skew flange from 0-45°. Bend other flange back along centerline of slots until it meets the header. Bend one time only.

STEP 3
Attach hanger to the carrying member, acute angle side first (see footnote 5). Install nails at an angle.

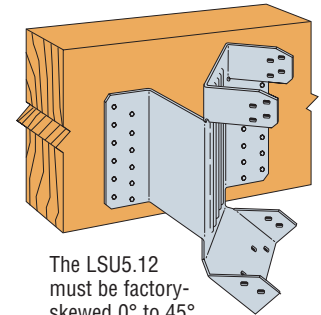
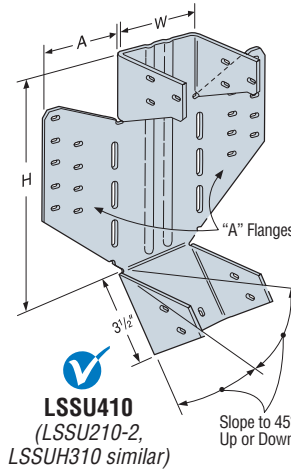

The LSU5.12 must be factory-skewed 0° to 45°. It may be field-sloped to 45°. (LSU4.12, LSU4.28 and LSU3510-2 similar)

Hanger shown skewed right

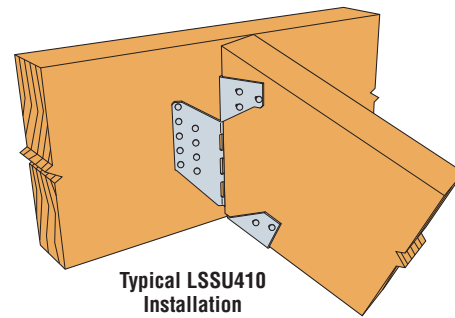

Typical LSSU410 Installation

Engineered Wood & Structural Composite Lumber Connectors

These products are available with additional corrosion protection. Additional products on this page may also be available with this option, check with Simpson Strong-Tie for details.

Actual Joist Width	Model No.	Ga	Dimensions			Fasteners		Allowable Loads								Code Ref.
			W	H	A	Face	Joist	DF/SP Species Header				SPF/HF Species Header				
								Uplift (160)	Floor (100)	Snow (115)	Const. (125)	Uplift (160)	Floor (100)	Snow (115)	Const. (125)	
SLOPED ONLY HANGERS																
1½	LSSU210	18	1⅞	8½	1½	10-10d	7-10dx1½	875	1110	1275	1390	625	960	1105	1200	18, L15, F7
1¾	LSSU25	18	1⅞	8½	1½	10-10d	7-10dx1½	875	1110	1275	1390	625	960	1105	1200	
2	LSSU2.06	18	2⅞	8½	1¾	10-10d	7-10dx1½	875	1110	1275	1390	625	960	1105	1200	170
2¼	LSSU2.1	18	2⅞	8½	1¾	10-10d	7-10dx1½	875	1110	1275	1390	625	960	1105	1200	18, L15, F7
2½ - 2⅝	LSSU35	18	2⅞	8½	1¾	10-10d	7-10dx1½	875	1110	1275	1390	625	960	1105	1200	
2½ - 2⅝	LSSUH310	16	2⅞	8½	3½	18-16d	12-10dx1½	1150	2295	2295	2295	990	1930	1930	1930	170
3	LSSU210-2	16	3⅞	8½	2½	18-16d	12-10dx1½	1150	2430	2795	3035	990	2160	2485	2700	18, L15, F7
3½	LSSU410	16	3⅞	8½	2½	18-16d	12-10dx1½	1150	2430	2795	3035	990	2160	2485	2700	
4	LSU4.12	14	4⅞	9	2¼	24-16d	16-10dx1½	1150	3215	3700	4020	990	2785	3200	3480	170
4½	LSU4.28	14	4⅞	9	2½	24-16d	16-10dx1½	1150	3215	3700	4020	990	2785	3200	3480	
4½ - 4¾	LSU3510-2	14	4⅞	8⅞	3½	24-16d	16-10dx1½	1150	3215	3700	4020	990	2785	3200	3480	
5	LSU5.12	14	5⅞	9	2¼	24-16d	16-10dx1½	885	3215	3700	3785	760	2785	3200	3280	
SKewed HANGERS OR SLOPED AND SKewed HANGERS																
1½	LSSU210	18	1⅞	8½	1½	9-10d	7-10dx1½	785	995	1145	1205	625	860	995	1050	18, L15, F7
1¾	LSSU25	18	1⅞	8½	1½	9-10d	7-10dx1½	785	995	1145	1205	625	860	995	1050	
2	LSSU2.06	18	2⅞	8½	1¾	9-10d	7-10dx1½	785	995	1145	1205	625	860	995	1050	170
2¼	LSSU2.1	18	2⅞	8½	1¾	9-10d	7-10dx1½	785	995	1145	1205	625	860	995	1050	18, L15, F7
2½ - 2⅝	LSSU35	18	2⅞	8½	1¾	9-10d	7-10dx1½	785	995	1145	1205	625	860	995	1050	
2½ - 2⅝	LSSUH310	16	2⅞	8½	3½	14-16d	12-10dx1½	1150	1600	1600	1600	990	1385	1385	1385	170
3	LSSU210-2	16	3⅞	8½	2½	14-16d	12-10dx1½	1150	1625	1625	1625	990	1365	1365	1365	18, L15, F7
3½	LSSU410	16	3⅞	8½	2½	14-16d	12-10dx1½	1150	1625	1625	1625	990	1365	1365	1365	
4	LSU4.12 ³	14	4⅞	9	2¼	24-16d	16-10dx1½	1150	2300	2300	2300	990	1990	1990	1990	170
4½	LSU4.28 ³	14	4⅞	9	2½	24-16d	16-10dx1½	1150	2300	2300	2300	990	1990	1990	1990	
4½ - 4¾	LSU3510-2 ³	14	4⅞	8⅞	3½	24-16d	16-10dx1½	1150	2300	2300	2300	990	1990	1990	1990	
5	LSU5.12 ³	14	5⅞	9	2¼	24-16d	16-10dx1½	885	1790	1790	1790	760	1550	1550	1550	

1. Roof loads are 125% of floor loads unless limited by other criteria.
2. Uplift loads include a 60% increase for wind or earthquake loading with no further increase is allowed; reduce where other loads govern.
3. LSU3510-2, LSU4.12, LSU4.28 and LSU5.12 skew option must be factory-ordered.
4. Minimum 11" joist height for LSU3510-2, LSU4.12, LSU5.12; 9½" for all others.
5. For skewed LSSU/LSSUI hangers, the inner most face fasteners on the acute angle side are not installed.
6. Do not substitute 10dx1½" nails for face nails on slope and skew combinations or skewed only LSU, LSSU and LSSUI. See pages 22-23 for other nail sizes and information.
7. **NAILS:** 16d = 0.162" dia. x 3½" long, 10d = 0.148" dia. x 3" long, 10dx1½" = 0.148" dia. x 1½" long. See pages 22-23 for other nail sizes and information.

VPA Variable Pitch Connector

The VPA may be sloped in the field, offering a versatile solution for attaching rafters to the top plate. It will adjust to accommodate slopes between 3:12 and 12:12, making it a complement to the versatile LSSU. This connector eliminates the need for notched rafters, beveled top plates and toe nailing.

MATERIAL: 18 gauge

FINISH: Galvanized

INSTALLATION: • Use all specified fasteners. See General Notes.

CODES: See page 12 for Code Reference Key Chart.

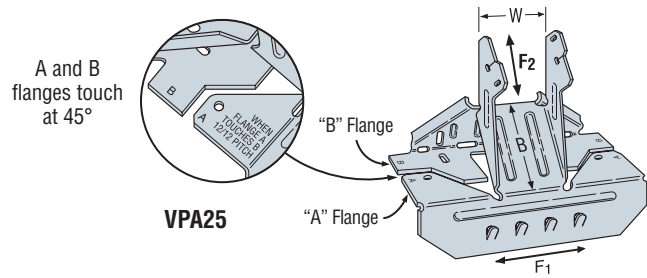

Actual Joist Width	Model No.	W	B	Fasteners		Allowable Loads								Code Ref.
				Carrying Member	Carried Member	Uplift		Download		Lateral				
						DF/SP Species	SPF Species			DF/SP Species (160)		SPF/HF Species (160)		
						(160)	(160)	F ₁	F ₂	F ₁	F ₂			
1½	VPA2	1⅞	2	8-10d	2-10dx1½	295	250	1050	870	375	250	325	250	18, L15, F7
1¾	VPA25	1⅞	2	8-10d	2-10dx1½	295	250	1050	870	375	250	325	250	
2	VPA2.06	2⅞	2	9-10d	2-10dx1½	295	250	1230	1020	375	250	325	250	170
2⅞	VPA2.1	2⅞	2	9-10d	2-10dx1½	295	250	1230	1020	375	250	325	250	
2¼ - 2⅞	VPA35	2⅞	2	9-10d	2-10dx1½	295	250	1230	1020	375	250	325	250	18, L15, F7
2½ - 2⅞	VPA3	2⅞	2	9-10d	2-10dx1½	295	250	1230	1020	375	250	325	250	
3½	VPA4	3⅞	2	11-10d	2-10dx1½	295	250	1230	1020	375	250	325	250	

1. Uplift loads include a 60% increase for wind or earthquake loading with no further increase allowed; reduce where other loads govern.
2. Loads may not be increased for short-term loading.
3. **NAILS:** 10d = 0.148" dia. x 3" long, 10dx1½ = 0.148" dia. x 1½" long. See pages 22-23 for other nail sizes and information.

VPA INSTALLATION SEQUENCE

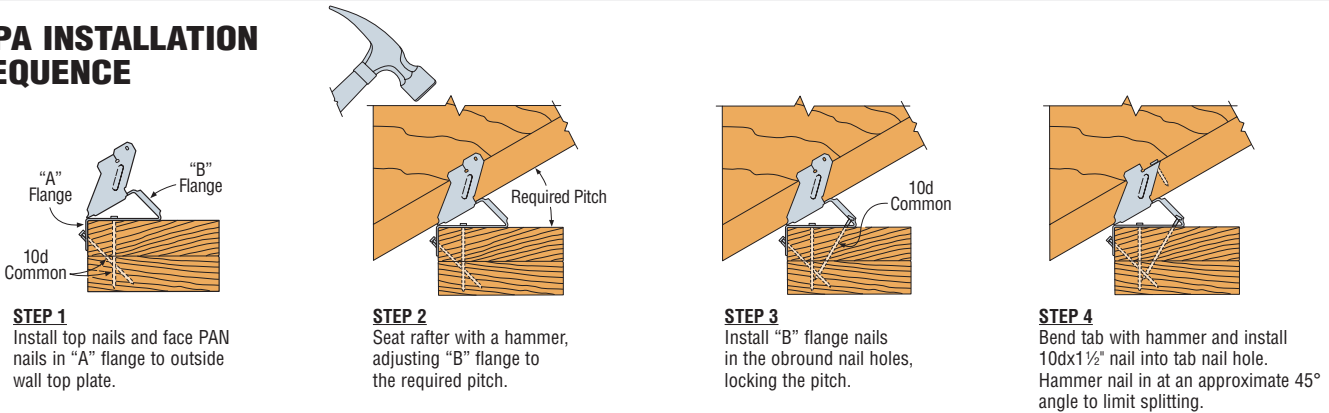

HCP Hip Corner Plates

For complementary ridge connection, see page 135

The HCP connects a rafter or joist to double top plates at a 45° angle.

MATERIAL: 18 gauge

FINISH: Galvanized

INSTALLATION: • Use all specified fasteners. See General Notes.

- Attach HCP to double top plates.
- Birdsmouth not required for table uplift loads but may be required for download.
- Install rafter and complete nailing. Rafter may be sloped to 45°.

CODES: See page 12 for Code Reference Key Chart.

Member Size	Model No.	Fasteners		DF/SP Allowable Loads (160)		SPF/HF Allowable Loads (160)		Code Ref.
		To Rafters	To Plates	Uplift	F ₁	Uplift	F ₁	
		1¾	HCP1.81	6-10dx1½	6-10dx1½	645	300	
3½	HCP4Z	8-10d	8-10d	1000	265	860	230	

1. Loads include a 60% increase for wind or earthquake loading with no further increase allowed; reduce where other loads govern.
2. The HCP can be installed on the inside and the outside of the wall with a flat bottom chord truss and achieve twice the load capacity.
3. **NAILS:** 10dx1½ = 0.148" dia. x 1½" long. See pages 22-23 for other nail sizes and information.

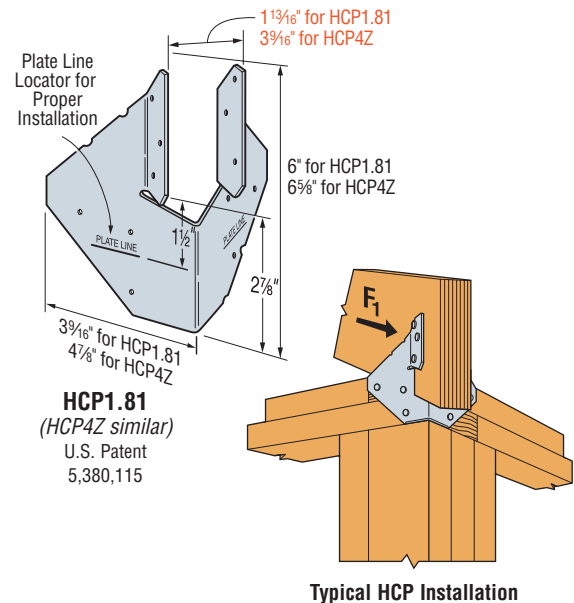

PAI/MPAI Purlin Anchors

Wood-to-concrete and wood-to-CMU connectors that satisfy code requirements for wind and seismic design categories (SDC) A-F. The PA's dual embedment line allows installation in concrete or CMU wall. The PAI and MPAI are code listed under the 2009 and 2012 IBC and IRC ESR-2920 and have been tested to meet the requirements of ICC-ES acceptance criteria AC-308 for cracked and un-cracked concrete.

MATERIAL: MPAI—14 gauge; PAI—12 gauge

FINISH: Galvanized. Some products available HDG or ZMAX® coating.

INSTALLATION:

- Use all specified fasteners; some models have extra fastener holes. See General Notes.
- Allowable loads are for a horizontal installation into the side of a concrete or CMU wall.

EDGE DISTANCE—Minimum concrete edge distance is 5". Minimum CMU wall left-to-right edge distance is 20".

CONCRETE CMU WALLS—The minimum wall specifications are:

- A** One #4 vertical rebar, 32" long, 16" each side of anchor;
- B** Two courses of grout filled block above and below the anchor (no cold joints allowed);
- C** A horizontal bond beam with two #4 rebars, 40" long, a maximum of two courses above or below the anchor.
- D** Minimum CMU compressive strength, $f'_m = 1500$ psi.

OPTIONS: See LTT and HTT Tension Ties.

CODES: See page 12 for Code Reference Key Chart.

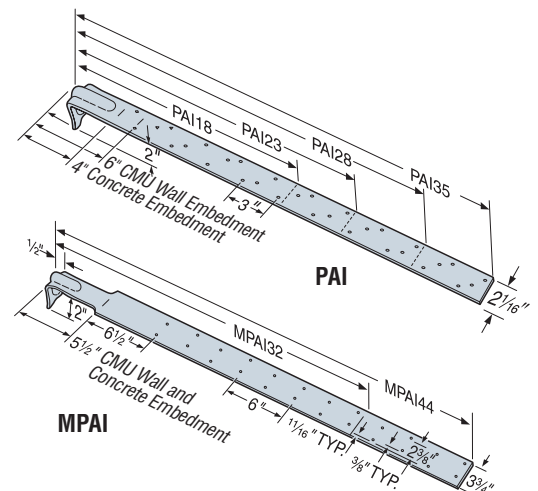

ASCE 7-10 12.11.2.2.5 states:

Diaphragm to structural wall anchorage using embedded straps shall be attached to, or hooked around the reinforcing steel, or otherwise terminated to effectively transfer forces to the reinforcing steel.

WIND AND SDC A & B – ALLOWABLE TENSION LOADS

Max. Ledger Size	Model No.	Strap Length, L (in.)	Embed. Length, l_e (in.)		Non-Cracked Concrete		Cracked Concrete		CMU Wall		Max. Allowable Strap Tensile Capacity	Code Ref.
			Concrete	CMU	Required Nails	Tension	Required Nails	Tension	Required Nails	Tension		
4x Ledger	PAI18	18½	4	6	9 -10dx1½	1820	9 -10dx1½	1820	9 -10dx1½	1055	NA	125
	PAI23	23¾	4	6	14 -10dx1½	2835	12 -10dx1½	2360	14 -10dx1½	1805	NA	
	PAI28	29	4	6	16 -10dx1½	3370	12 -10dx1½	2360	16 -10dx1½	2705	NA	
	PAI35	35	4	6	18 -10dx1½	3370	12 -10dx1½	2360	18 -10dx1½	2815	NA	
	MPAI32	32	5½		16 -10dx1½	2355	—	—	16 -10dx1½	2355	—	
	MPAI44	44	5½		24 -10dx1½	2865	—	—	24 -10dx1½	2865	—	

SDC C-F – ALLOWABLE TENSION LOADS

Max. Ledger Size	Model No.	Strap Length, L (in.)	Embed. Length, l_e (in.)		Non-Cracked Concrete		Cracked Concrete		CMU Wall		Max. Allowable Strap Tensile Capacity	Code Ref.
			Concrete	CMU	Required Nails	Tension	Required Nails	Tension	Required Nails	Tension		
4x Ledger	PAI18	18½	4	6	9 -10dx1½	1820	9 -10dx1½	1820	9 -10dx1½	1055	4180	125
	PAI23	23¾	4	6	14 -10dx1½	2830	10 -10dx1½	1980	14 -10dx1½	1805	4180	
	PAI28	29	4	6	20 -10dx1½	2830	10 -10dx1½	1980	16 -10dx1½	2705	5070	
	PAI35	35	4	6	26 -10dx1½	2830	10 -10dx1½	1980	18 -10dx1½	2815	5070	
	MPAI32	32	5½		—	—	—	—	16 -10dx1½	2355	—	
	MPAI44	44	5½		—	—	—	—	24 -10dx1½	2865	—	

1. Allowable loads have been increased for earthquake or wind load durations with no further increases allowed.
2. Deflection at highest allowable loads for standard installation are as follows: PAI18 = 0.10", PAI23 = 0.158", PAI28 = 0.167" and PAI35 = 0.13".
3. Multiply Seismic and Wind ASD load values by 1.4 or 1.6 respectively to obtain LRFD capacities.
4. Minimum center-to-center spacing is 3 times the required embedment for PA/HPA's acting in tension simultaneously, where l_e = embedment depth. Standard installation is based on minimum 5" end distance.
5. For wall anchorage systems in SDC C-F, the maximum allowable strap tensile capacity shall not be less than 1.4 times the ASD anchor design load.
6. Nail quantities are based on Douglas Fir (DF) or equivalent specific gravity of 0.50 or better. For use on Spruce-Pine-Fir (SPF) or Hem Fir (HF) nail quantities must be increased by 1.15 to achieve allowable loads.
7. Structural composite lumber beams have sides that show either the wide face or the lumber strands/veneers. Values in the tables reflect installation in the wide face.
8. Concrete shall have a minimum concrete strength, f'_c of 3000 psi. Minimum $f'_m = 1500$ psi for masonry.
9. 10dx1½ installation directly to framing. For installation over wood structural panel sheathing, use 2½" minimum nail lengths for ½" nominal sheathing.
10. **NAILS:** 10d = 0.148" dia. x 3" long, 10dx1½ = 0.148" dia. x 1½" long. See pages 22-23 for other nail sizes and information.

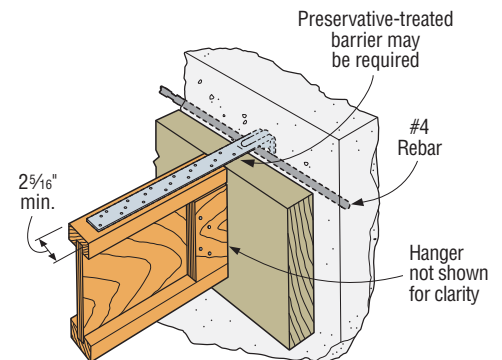

PAI Purlin to Concrete Wall
(MPAI similar)

STRONG-DRIVE® SDW TRUSS-PLY & EWP-PLY Screws

Engineered Wood & Structural Composite Lumber Connectors

The Strong-Drive® SDW Truss-Ply and EWP-Ply screws are a 0.22" diameter, high-strength structural wood screws specifically designed for fastening multi-ply wood members such as plated trusses, engineered-lumber products and solid-sawn lumber. The Strong-Drive SDW Truss-Ply and EWP-Ply screws install easily with no pre-drilling and is available in optimized lengths for fastening 2, 3 and 4-ply trusses or 1¼" engineered lumber such as structural composite lumber (SCL). The Strong-Drive SDW Truss-Ply and EWP-Ply screws enable single-side fastening, while still allowing concurrent loading on both sides of the assembly to the full allowable head or point-side load of the fastener.

- Low-profile head for reduced interference during handling or installation of hardware on the assembly
- High shear values enable wider screw spacing
- Bold thread design firmly cinches plies together to close gaps in multi-ply assemblies
- Optimal screw lengths provide maximum penetration

MATERIAL: Heat-treated carbon steel **FINISH:** Black E-coat™

WARNING: Industry studies show that hardened fasteners can experience performance problems in wet or corrosive environments. Accordingly, the Strong-Drive SDW Truss-Ply and EWP-Ply screws should only be used in dry, interior and non-corrosive environments.

INSTALLATION: • Use all specified fasteners. See General Notes.

- Strong-Drive SDW Truss-Ply and EWP-Ply screws install best with a low-speed ½" drill motor and a T-40 6-lobe bit. The matched bit included with the screws is recommended for best results.
- Pre-drilling is typically not required. Strong-Drive SDW Truss-Ply and EWP-Ply screws may be installed through metal truss plates as approved by the Truss Designer, provided the requirements of ANSI/TPI 1-2007 Section 8.9.2 are met (*pre-drilling required through the plate using a maximum of ½" bit*).
- Screw heads that are countersunk flush to the wood surface are acceptable if the screw has not spun out.
- Individual screw locations may be adjusted up to 3" to avoid conflicts with other hardware or to avoid lumber defects.

NOTES TO THE DESIGNER:

1. Single-fastener shear loads and withdrawal loads in this section, are based on testing per ICC-ES AC233. Allowable withdrawal load for DF/SP/SCL is 200 pounds per inch (lbs./in.) and for SPF/HF withdrawal is 150 lbs./in. of thread length penetration into the main member. Total allowable withdrawal load is based on actual thread penetration into the main member.
2. Allowable loads in tables are shown at the load duration factor of $C_D = 1.00$ and shall be multiplied by all applicable adjustment factors per the NDS. Loads may be increased for load duration per the building code up to a C_D of 1.6.
3. Minimum fastener spacing requirements: 6" end distance, 1¼" edge distance, ¾" between staggered rows of fasteners, 4" between non-staggered rows of fasteners and 6" between fasteners in a row. Note exceptions in the application drawing at the top of page 142.
4. Maximum fastener spacing is recommended not to exceed 24" on-center except as approved by a qualified Designer.
5. Structural composite lumber (SCL = LVL, PSL or LSL) loads assume an equivalent Specific Gravity of 0.50 or higher for fastener shear in the wide face (*unless otherwise noted*).
6. Tabular loads in this document are based on the capacity of the Simpson Strong-Tie Strong-Drive SDW Truss-Ply and EWP-Ply screws. The capacity of the multi-ply assembly must be checked by a qualified Designer.
7. For top loaded solid sawn 2x built-up assemblies that are evenly loaded across the entire assembly width, the recommended fastener spacing is two rows at 32" o.c.. For top-loaded SCL 1¼" built up assemblies that are evenly loaded across the entire assembly width, the recommended fastener spacing is two rows at 24" o.c. for up to 18" deep members, and 3 rows at 24" o.c. for members deeper than 18".

CODES: IAPMO-UES ER-192; City of L.A. RR25906

Product Information

Model No. ^{2,3}	Head Stamp Length	Nominal Screw Length (L) (in.)	Typical Application ¹	Thread Length (TL) (in.)	Retail Box ³ Quantity (1 Bit)	Retail Boxes/ Carton	Mini-Bulk Bucket Quantity ² (1 Bit)	Bulk Bucket Quantity (2 Bits)
SDW22300	3.00	2½"	2x/Truss	1⅞"	50	6	250	950
SDW22338	3.37	3"	SCL	1⅞"	50	6	250	900
SDW22438 ⁴	4.37	4"	2x/Truss Desert	1⅞"	50	4	200	600
SDW22458 ⁴	4.62	4"	2x/Truss	1⅞"	50	4	200	600
SDW22500	5.00	5"	SCL/3x2PCT	1⅞"	50	4	200	600
SDW22600 ⁵	6.00	6"	2x/Truss Desert	1⅞"	50	4	200	500
SDW22638 ⁵	6.37	6"	2x/Truss	1⅞"	50	4	200	500
SDW22634	6.75	6"	SCL/4x2PCT	1⅞"	50	4	200	500

1. Typical screw application key:
2x/Truss = Solid-sawn dimensional lumber and plated wood trusses.
2x/Truss Desert = Solid-sawn dimensional lumber and plated wood trusses in desert environments (*scant lumber*).
SCL = 1¼" plies of structural-composite lumber.
SCL/3x2PCT = 1¼" plies of structural-composite lumber or double 3x2 parallel-chord trusses.
SCL/4x2PCT = 1¼" or 3½" plies of structural-composite lumber or double 4x2 parallel-chord trusses.
2. To order mini-bulk buckets add the letters MB to the model number, e.g. SDW22458MB.
3. To order retail pack boxes add "-R50" to the model number, e.g. SDW22458-R50.
4. If assembly is less than or equal to 4⅞" thick, use the SDW22438.
5. If assembly is less than or equal to 6⅞" thick, use the SDW22600.

Table 1 – Strong-Drive® SDW TRUSS-PLY and EWP-PLY Screws Allowable Shear Loads – DF, SP, SPF, HF Lumber and 2x Truss Loaded on Head Side

Assembly	Model No.	Nominal Screw Length (in.)	Thread Length (in.)	Nominal Side Member Thickness (in.)	Main Member Penetration (in.)	DF/SP Allowable Shear	SPF/HF Allowable Shear	Code Ref.
2-ply 2x/Truss	SDW22300	2½"	1⅞"	1½"	1¾"	325	255	IP4, F32, L23
3-ply 2x/Truss Desert	SDW22438	4"	1⅞"	1½"	2"	400	325	
3-ply 2x/Truss	SDW22458	4"	1⅞"	1½"	2"	400	325	
4-ply 2x/Truss Desert	SDW22600	6"	1⅞"	1½"	4½"	400	340	
4-ply 2x/Truss	SDW22638	6"	1⅞"	1½"	4½"	400	340	

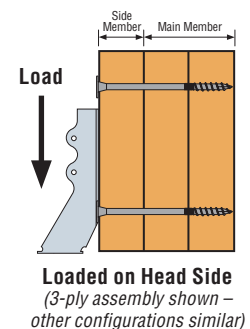

1. For minimum penetration into main member of 1⅞", use 235 lbs. for DF/SP and 210 lbs. for SPF/HF.

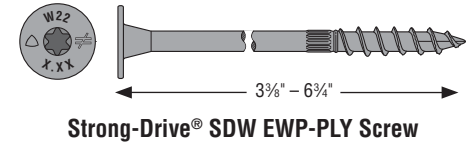
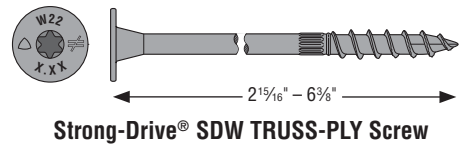

U.S. Patents 5,897,280;
7,101,133 and 6,109,850



T-40 Driver Bit
(included)
BIT40-R1

STRONG-DRIVE® SDW TRUSS-PLY & EWP-PLY Screws

Table 2 – Strong-Drive® SDW TRUSS-PLY and EWP-PLY Screws Allowable Shear Loads – DF, SP, SPF, HF Lumber and 2x Truss Loaded on Point Side

Assembly	Model No.	Nominal Screw Length (in.)	Thread Length (in.)	Nominal Side Member Thickness (in.)	Main Member Penetration (in.)	DF/SP Allowable Shear	SPF/HF Allowable Shear	Code Ref.
2-ply 2x/Truss	SDW22300	2 ¹ / ₆	1 ¹ / ₆	1 ¹ / ₂	1 ³ / ₈ ¹	325	255	IP4, F32
3-ply 2x/Truss Desert	SDW22438	4 ³ / ₈	1 ¹ / ₆	3	1 ³ / ₈ ¹	275	255	170
3-ply 2x/Truss	SDW22458	4 ³ / ₈	1 ¹ / ₆	3	1 ³ / ₈ ¹	275	255	
4-ply 2x/Truss Desert	SDW22600	6	1 ¹ / ₆	4 ¹ / ₂	1 ³ / ₈ ¹	275	255	
4-ply 2x/Truss	SDW22638	6 ³ / ₈	1 ¹ / ₆	4 ¹ / ₂	1 ³ / ₈ ¹	275	255	

1. For minimum penetration into main member of 1¹/₂" use 235 lbs. for DF/SP and 210 lbs. for SPF/HF.

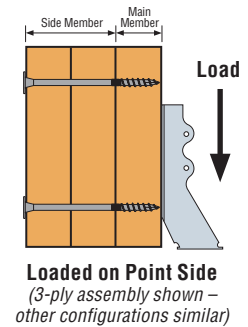

LUMBER FASTENING IN DRY CLIMATES

The highlighted regions on this map may experience drier conditions which can result in reduced lumber thickness (*scant lumber*) due to wood shrinkage. To help ensure optimum thread penetration into the main (*last*) member without excessive protrusion, Simpson Strong-Tie offers the 4³/₈" and 6" lengths of the SDW screw, which are sized for the thinner members common in these “desert” climates (*see table above*). It is the responsibility of the Truss Manufacturer or contractor/installer to determine the appropriate fastener length for any given application. (*See tables and footnotes for minimum required penetration.*)

Engineered Wood & Structural Composite Lumber Connectors

Table 3 – Strong-Drive® SDW TRUSS-PLY and EWP-PLY Screws Allowable Shear Loads – LVL, PSL and LSL Loaded on Head Side

Assembly	Model No.	Nominal Screw Length (in.)	Thread Length (in.)	Nominal Side Member Thickness (in.)	Main Member Penetration (in.)	Equivalent Specific Gravity 0.50 Allowable Shear	Equivalent Specific Gravity 0.42 Allowable Shear	Code Ref.
2-ply 1 ¹ / ₄ " SCL	SDW22338	3 ³ / ₈	1 ¹ / ₆	1 ¹ / ₄	1 ³ / ₈ ¹	400	255	IP4, F32
3-ply 1 ¹ / ₄ " SCL	SDW22500	5	1 ¹ / ₆	1 ¹ / ₄	3 ¹ / ₄	400	325	
4-ply 1 ¹ / ₄ " SCL	SDW22634	6 ³ / ₈	1 ¹ / ₆	1 ¹ / ₄	5	400	385	
2-ply 3 ¹ / ₂ " SCL	SDW22634	6 ³ / ₈	1 ¹ / ₆	3 ¹ / ₂	3 ¹ / ₄	400	—	

1. For minimum penetration into main member of 1¹/₂", use 300 lbs.

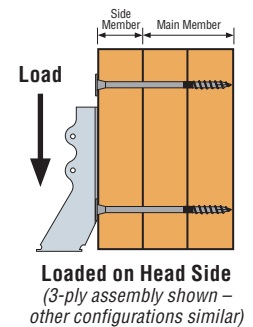
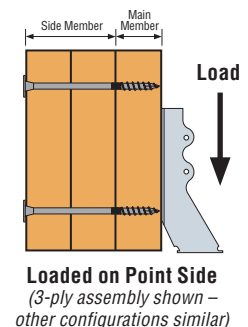

Table 4 – Strong-Drive® SDW TRUSS-PLY and EWP-PLY Screws Allowable Shear Loads – LVL, PSL and LSL Loaded on Point Side

Assembly	Model No.	Nominal Screw Length (in.)	Thread Length (in.)	Nominal Side Member Thickness (in.)	Main Member Penetration (in.)	Equivalent Specific Gravity 0.50 Allowable Shear	Equivalent Specific Gravity 0.42 Allowable Shear	Code Ref.
2-ply 1 ¹ / ₄ " SCL	SDW22338	3 ³ / ₈	1 ¹ / ₆	1 ¹ / ₄	1 ³ / ₈ ¹	400	255	IP4, F32
3-ply 1 ¹ / ₄ " SCL	SDW22500	5	1 ¹ / ₆	3 ¹ / ₂	1 ¹ / ₂	300	255	170
4-ply 1 ¹ / ₄ " SCL	SDW22634	6 ³ / ₈	1 ¹ / ₆	5 ¹ / ₄	1 ¹ / ₂	300	255	
2-ply 3 ¹ / ₂ " SCL	SDW22634	6 ³ / ₈	1 ¹ / ₆	3 ¹ / ₂	3 ¹ / ₄	400	—	IP4, F32

1. For minimum penetration into main member of 1¹/₂", use 300 lbs.



STRONG-DRIVE® SDW TRUSS-PLY & EWP-PLY Screws

Table 5 – Strong-Drive® SDW TRUSS-PLY and EWP-PLY Screws Allowable Shear Loads – Two-Ply 3x2/4x2 Parallel-Chord Trusses Loaded on Either Side

Assembly	Model No.	Nominal Screw Length (in.)	DF/SP Allowable Shear	SPF/HF Allowable Shear	Code Ref.
2-ply 3x2 PCT	SDW22500	5	280	200	170
2-ply 4x2 PCT	SDW22634	6¾	280	200	

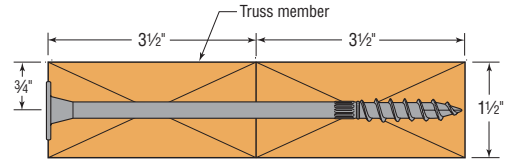

Strong-Drive® SDW Screw Position in 2-Ply 4x2 Truss (2-ply 3x2 similar)

- To transfer uniform or concentrated loads applied to simply supported spans on assembly top chord:
 - Space screws as required to transfer half the load into the supporting truss.
 - Minimum screw spacing shall be 4" o.c.
- To transfer concentrated loads applied to simply supported spans on an assembly top chord or vertical web:
 - Concentrated loads must be applied at a panel point.
 - Screws to be installed within 12" of the concentrated load on top-chord assembly.
- Gap between the trusses shall not exceed 1/8".
- Floor sheathing shall be screwed or nailed to each top-chord ply. (*Fastener spacing per the applicable Code requirements, or 12" o.c.*)
- Strong-Drive® SDW screws shall not be installed in areas where lumber wane exceeds 1/4".
- Hangers on skewed girders:
 - Hanger loads not exceeding 34" o.c. on a skewed girder (*resulting from uniformly spaced joists up to 24" o.c.*) may be converted to a uniform load.
 - For girders with hanger load spacing in excess of 34" o.c. the loads shall be considered as concentrated loads at the applicable locations.
- Other configurations acceptable as long as approved by Truss Designer.

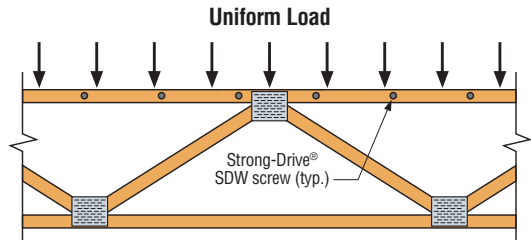
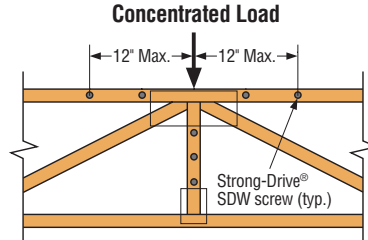

Table 6 – Strong-Drive® SDW TRUSS-PLY and EWP-PLY Screws Allowable Uniform Load Applied to Either Outside Member – Side-Loaded Multi-Ply Assemblies

Multiple Members		Nominal Screw Length (in.)	Loaded Side	DF/SP						SPF/HF					
Assembly	Components			12" o.c.		16" o.c.		24" o.c.		12" o.c.		16" o.c.		24" o.c.	
				2 Rows	3 Rows	2 Rows	3 Rows	2 Rows	3 Rows	2 Rows	3 Rows	2 Rows	3 Rows	2 Rows	3 Rows
A-W	2-ply 2x/Truss	2¾	Either	1300	1950	975	1465	650	975	1020	1530	765	1150	510	765
B-W	3-ply 2x/Truss	4¾ or 4¾	Head	1200	1800	900	1350	600	900	975	1465	730	1095	490	730
			Point	825	1240	620	930	415	620	765	1150	575	860	385	575
C-W	4-ply 2x/Truss	6 or 6¾	Head	1065	1600	800	1200	535	800	905	1360	680	1020	455	680
			Point	735	1100	550	825	365	550	680	1020	510	765	340	510

- Each ply is assumed to carry same proportion of load.
- Loads may be applied to the head side and point side concurrently provided neither published allowable load is exceeded. (*Example: a 3-ply DF assembly with a head side load of 1300 plf and point side load of 900 plf may be fastened together with 3 rows of SDW @ 16" o.c.*)
- When hangers are installed on point side, hanger face fasteners must be a minimum of 3" long.
- Tables are based on Main Member Penetration as noted in Tables 1 and 2.
- Hanger load spacing on the multi-ply assembly should not exceed 24" o.c. Exception: On a skewed girder, hanger loads up to 34" o.c. (*resulting from joists uniformly spaced up to 24" o.c.*) may be converted to a uniform load.

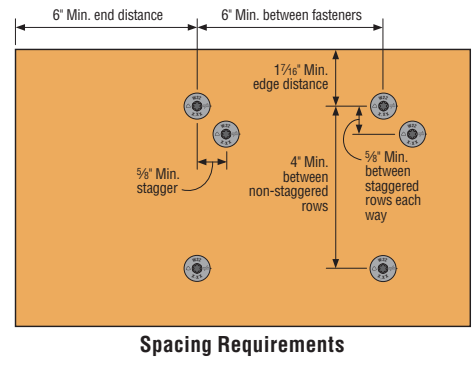
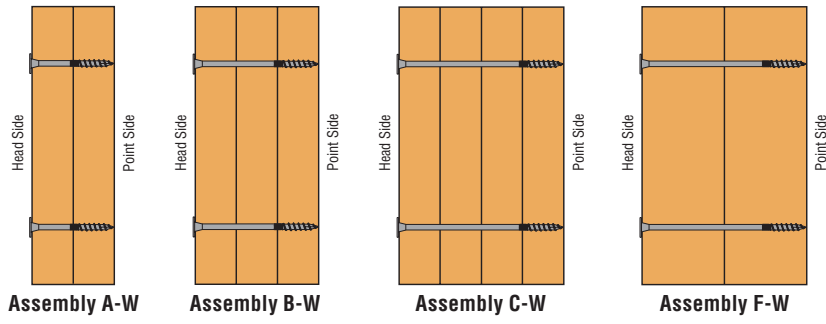

Table 7 – Strong-Drive® SDW TRUSS-PLY and EWP-PLY Screws Allowable Uniform Load Applied to Either Outside Member – Side-Loaded Multi-Ply LVL, PSL and LSL Assemblies

Multiple Members		Nominal Screw Length (in.)	Loaded Side	12" o.c.		16" o.c.		24" o.c.	
Assembly	Components			2 Rows	3 Rows	2 Rows	3 Rows	2 Rows	3 Rows
A-W	2-ply SCL	3¾	Either	1600	2400	1200	1800	800	1200
B-W	3-ply SCL	5	Head	1200	1800	900	1350	600	900
			Point	900	1350	675	1015	450	675
C-W	4-ply SCL	6¾	Head	1065	1600	800	1200	535	800
			Point	800	1200	600	900	400	600
F-W	2-ply 3½" SCL	6¾	Either	1600	2400	1200	1800	800	1200

- Each ply is assumed to carry same proportion of load.
- Loads may be applied to the head side and point side concurrently provided neither published allowable load is exceeded. (*Example: a 3-ply assembly with a head side load of 1300 plf and point side load of 1000 plf may be fastened together with 3 rows of SDW @ 16" o.c.*)
- When hangers are installed on point side, hanger face fasteners must be a minimum of 3" long.
- Tables are based on Main Member Penetration as noted in single-fastener load tables 3 and 4.

THA/THAC Adjustable Truss Hangers



This product is preferable to similar connectors because of a) easier installation, b) higher loads, c) lower installed cost, or a combination of these features.

The THA series have extra long straps that can be field-formed to give height adjustability and top flange hanger convenience. THA hangers can be installed as top flange or face mount hangers.

THA4x and THA2x-2 models feature a dense nail pattern in the straps, which provides more installation options and allows for easy top flange installation.

MATERIAL: See table

FINISH: Galvanized. Some products available in ZMAX® coating; see Corrosion Information, pages 13-15.

INSTALLATION: • Use all specified fasteners. See General Notes.

The following installation methods may be used:

- **Top Flange Installation**—The straps must be field formed over the header – see table for minimum top flange requirements. Install top and face nails according to the table. Top nails shall not be within 1/4" from the edge of the top flange members. For the THA29, nails used for joist attachment must be driven at an angle so that they penetrate through the corner of the joist and into the header. For all other top flange installations, straighten the double shear nailing tabs and install the nails straight into the joist.
- **Face Mount Installation**—Install all face nails according to the table. Not all nail holes will be filled on all models. On models where there are more nail holes than required, the lowest 4 face holes must be filled. Nails used for the joist attachment must be driven at an angle so that they penetrate through the corner of the joist into the header.
- **Alternate Installation**—The THA 4x hangers may be installed in a top flange configuration using the tabulated fasteners for face mount installation and achieve the face mount installation loads. Install the tabulated face nails into the face and top of the carrying member. Nails used for the joist attachment must be driven at an angle so that they penetrate through the corner of the joist into the header.
- **Uplift**—Lowest face nails must be filled to achieve uplift loads.

OPTIONS: • THA hangers available with the header flanges turned in for 3/8" (except THA413) and larger, with no load reduction – order THAC hanger.

CODES: See page 12 for Code Reference Key Chart.



Double-Shear Nailing Top View

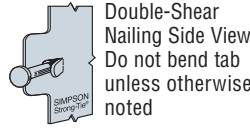

Double-Shear Nailing Side View
Do not bend tab unless otherwise noted

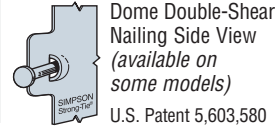

Dome Double-Shear Nailing Side View (available on some models)
U.S. Patent 5,603,580

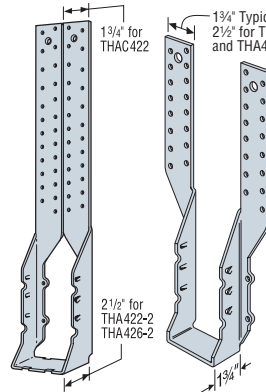

THAC422

THA418



THA29

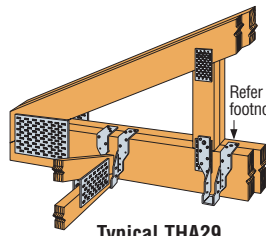

Typical THA29 Top Flange Installation

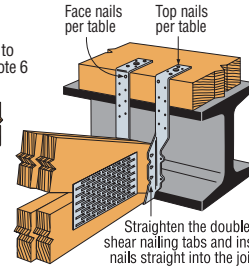

Typical THA422 Top Flange Installation on a 4x2 Floor Truss

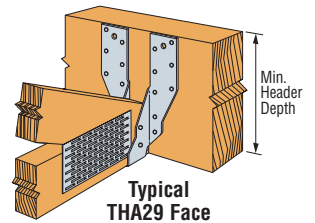

Typical THA29 Face Mount Installation

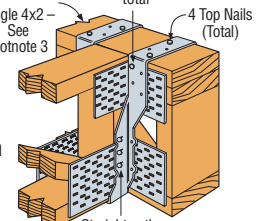

Typical THA Top Flange Installation on a Nailers (except THA29)

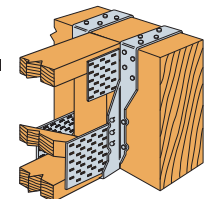

Alternate Installation of THA422

Plated Truss Connectors

These products are available with additional corrosion protection. Additional products on this page may also be available with this option, check with Simpson Strong-Tie for details.

Model No.	Ga	Dimensions			Min. ⁵ Top Flange	Min. Header Depth	Fasteners				DF/SP Allowable Loads					SPF/HF Allowable Loads					Code Ref.	
		W	H	C			Carrying Member		Carried Member		Uplift (160)	Floor (100)	Snow (115)	Roof (125)	Wind (160)	Uplift (160)	Floor (100)	Snow (115)	Roof (125)	Wind (160)		
							Top	Face	Straight	Slant												
TOP FLANGE INSTALLATION³																						
THA29	18	1 1/8	9 1/16	5 1/2	2 1/16	—	4-10d	4-10d	—	4-10d	560	2260	2310	2350	2350	480	1740	1785	1815	1815	18, L15, F7	
THA213	18	1 1/8	13 3/16	5 1/2	1 1/2	—	4-10d	2-10d	4-10dx1 1/2	—	—	1615	1615	1615	1615	—	1280	1280	1280	1280		
THA218	18	1 1/8	17 3/16	5 1/2	2	—	4-10d	2-10d	4-10dx1 1/2	—	—	1615	1615	1615	1615	—	1280	1280	1280	1280		
THA218-2	16	3/8	17 1/16	8	2	—	4-16d	2-16d	6-10d	—	—	2245	2245	2245	2245	—	1935	1935	1935	1935		
THA222-2	16	3/8	22 3/16	8	2	—	4-16d	2-16d	6-10d	—	—	2245	2245	2245	2245	—	1935	1935	1935	1935		
THA413	18	3/8	13 3/16	4 1/2	1 1/2	—	4-10d	2-10d	4-10d	—	—	1615	1615	1615	1615	—	1280	1280	1280	1280		
THA418	16	3/8	17 1/2	7 1/2	2	—	4-16d	2-16d	6-10d	—	—	2245	2245	2245	2245	—	1935	1935	1935	1935		
THA422	16	3/8	22	7 1/2	2	—	4-16d	2-16d	6-10d	—	—	2245	2245	2245	2245	—	1935	1935	1935	1935		
THA426	14	3/8	26	7 1/2	2	—	4-16d	4-16d	6-16d	—	—	2435	2435	2435	2435	—	2095	2095	2095	2095		F23
THA422-2	14	7/16	22 1/16	9 3/4	2	—	4-16d	4-16d	6-16d	—	—	3330	3330	3330	3330	—	2865	2865	2865	2865		170
THA426-2	14	7/16	26 1/16	9 3/4	2	—	4-16d	4-16d	6-16d	—	—	3330	3330	3330	3330	—	2865	2865	2865	2865	170	
FACE MOUNT INSTALLATION⁴																						
THA29	18	1 1/8	9 1/16	5 1/2	—	9 1/16	—	16-10d	—	4-10d	560	2125	2310	2350	2350	480	1740	1785	1815	1815	18, L15, F7	
THA213	18	1 1/8	13 3/16	5 1/2	—	13 3/16	—	14-10d	—	4-10d	1170	1940	2000	2030	2030	780	1385	1425	1450	1450		
THA218	18	1 1/8	17 3/16	5 1/2	—	17 3/16	—	18-10d	—	4-10d	1170	1940	2000	2030	2030	780	1385	1425	1450	1450		
THA218-2	16	3/8	17 1/16	8	—	14 1/16	—	22-16d	—	6-16d	1855	3695	3695	3695	3695	1595	3185	3185	3185	3185		
THA222-2	16	3/8	22 3/16	8	—	14 1/16	—	22-16d	—	6-16d	1855	3695	3695	3695	3695	1595	3185	3185	3185	3185		
THA413	18	3/8	13 3/16	4 1/2	—	13 3/16	—	14-10d	—	4-10d	1170	1940	2235	2400	2400	780	1660	1910	2075	2210		
THA418	16	3/8	17 1/2	7 1/2	—	14 1/16	—	22-16d	—	6-16d	1855	3695	3695	3695	3695	1595	3185	3185	3185	3185		
THA422	16	3/8	22	7 1/2	—	14 1/16	—	22-16d	—	6-16d	1855	3695	3695	3695	3695	1595	3185	3185	3185	3185		
THA426	14	3/8	26	7 1/2	—	16 1/16	—	30-16d	—	6-16d	1855	4550	4550	4550	4550	1595	3915	3915	3915	3915		F23
THA422-2	14	7/16	22 1/16	9 3/4	—	16 3/16	—	30-16d	—	6-16d	1855	5160	5520	5520	5520	1595	4440	4745	4745	4745		170
THA426-2	14	7/16	26 1/16	9 3/4	—	18	—	38-16d	—	6-16d	1855	5520	5520	5520	5520	1595	4745	4745	4745	4745	170	

- Uplift has been increased 60% for wind or earthquake loading with no further increase allowed; reduce where other loads govern.
- Wind (160) is a download rating.
- For single 4x2 top chord carrying members or single 2x nailers, the following THA hangers can be installed using 10dx1 1/2" top nails and 2-16d face nails with reduced allowable loads as noted: THA418/THA422: 1415 lbs. for DF/SP, 1215 lbs. for SPF; THA426: 2245 lbs. for DF/SP, 1930 lbs. for SPF; THA422-2/THA426-2: 2345 lbs. for DF/SP, 2015 lbs. for SPF. Loads are based on hanger installations at panel points.
- Face mount installation loads are based on minimum of 2-ply 2x

- carrying member. For single 2x carrying members, use 10dx1 1/2" nails into the carrying member and tabulated fasteners on the carried member, and use 0.80 of the table value for 18 gauge, and 0.68 of the table value for 16 gauge and 14 gauge.
- Min. Top Flange refers to the minimum length of strap that must be field formed over the header.
- For the THA 2x models, one strap may be installed vertically according to the face mount nailing requirements and the other strap wrapped over the truss chord according to the top flange nailing requirements (see drawing above) and achieve full tabulated top flange installation loads.
- NAILS:** 16d = 0.162" dia. x 3 1/2" long, 10d = 0.148" dia. x 3" long, 10dx1 1/2 = 0.148" dia. x 1 1/2" long. See pages 22-23 for other nail sizes and information.

THASR/L Adjustable/Skewable Truss Hangers

The THASR/L hangers combine the height adjustability of THA hangers with field skewability, offering maximum flexibility for the installer, and eliminating the need for special orders. Shipped at 22½° right or left, the THASR/L hangers can be field skewed from 22½° to 75° (up to 85° for the THASR/L29 and THASR/L29-2).

The new THASR/L29, 29-2 and 422 are replacing the former 218, 218-2 and 418 versions.

- FEATURES:**
- The THASR/L single and two-ply versions have straps 9" tall.
 - The 4x version has 22" straps to fit more parallel-chord truss applications.
 - The new versions have only one acute side bend line to ease design and installation.
 - Joist fasteners are only required from one side for skews greater than 22½°.
 - Rated for installation with either nails or Simpson Strong-Tie® Strong-Drive® SD Connector screws.

MATERIAL: 16 gauge **FINISH:** Galvanized

INSTALLATION: • Use all specified fasteners. See General Notes.

- Product is factory skewed to 22½° and may be field skewed from 22½° to 75° (up to 85° for the THASR/L29 and THASR/L29-2). See Installation Sequence below for skews greater than 22½°.
- For 22½° skew installations, fill all triangle holes. Triangle holes do not need to be filled for skews greater than 22½°.
- For all installations, fill the fastener hole(s) in the bottom of the hanger seat (THASR/L29 has one and all other models have two).
- For top flange installations, the straps must be field-formed over the header a minimum of 2".
- THASR/L29 and THASR/L29-2—For installations where either strap cannot be field-formed over the header, install the strap(s) vertical and fill all holes. Loads must be reduced as noted in the table footnotes.
- THASR/L422—For face-mount installations, install the carrying member fasteners into the lowest holes.

CODES: See page 12 for Code Reference Key Chart.

INSTALLATION SEQUENCE FOR SKEWS > 22½°

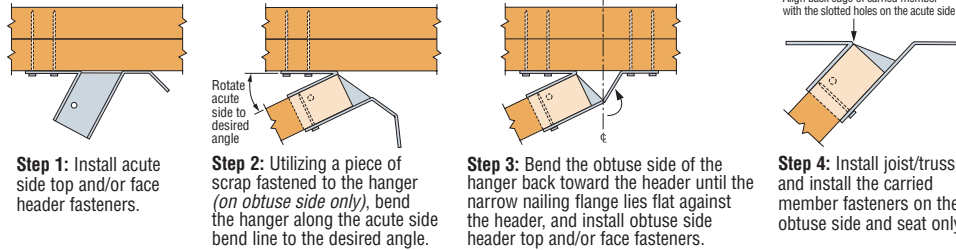

These products are available with additional corrosion protection. Additional products on this page may also be available with this option, check with Simpson Strong-Tie for details.

These products are approved for installation with the Strong-Drive® SD Connector screw. See page 27 for more information.

Allowable Loads for Installation with Nails

Min. Carried Member	Model No.	Dimensions		Min. Heff ⁴	Skew (Degree)	Fasteners			DF/SP Allowable Loads					SPF/HF Allowable Loads					Code Ref.
		W	H			Carrying Member		Carried Member	Uplift (160)	Floor (100)	Snow (115)	Roof (125)	Wind (160)	Uplift (160)	Floor (100)	Snow (115)	Roof (125)	Wind (160)	
						Top	Face												
TOP FLANGE INSTALLATION⁵																			
2x Truss	THASR/L29	1%	9%	5½"	22½°	4-10d	8-10d	7-10dx1½"	795	1975	1975	1975	1975	685	1695	1700	1700	1700	
					23 to 74	4-10d	8-10d	4-10dx1½"	385	1485	1485	1485	1485	330	1275	1275	1275	1275	
					75 to 85	4-10d	8-10d	4-10dx1½"	385	1850	1895	1895	1895	330	1380	1420	1445	1545	
2-2x Truss	THASR/L29-2	3%	9%	5½"	22½°	4-10d	8-10d	8-10d	825	1660	1660	1660	1660	710	1425	1425	1425	1425	
					23 to 45	4-10d	8-10d	5-10d	295	1285	1285	1285	1285	255	1105	1105	1105	1105	
					46 to 85	4-10d	8-10d	5-10d	260	1285	1285	1285	1285	225	1105	1105	1105	1105	
4x Truss	THASR/L422	3%	22"	8"	22½°	4-10d	4-10d	8-10d	—	1115	1115	1115	1115	—	960	960	960	960	
					23 to 45	4-10d	4-10d	5-10d	—	925	925	925	925	—	795	795	795	795	
					46 to 75	4-10d	4-10d	5-10d	—	745	745	745	745	—	640	640	640	640	
FACE MOUNT INSTALLATION																			
4x Truss	THASR/L422	3%	22"	5½"	22½°	—	8-10d	8-10d	—	810	810	810	810	—	700	700	700	700	
					23 to 45	—	8-10d	5-10d	—	730	730	730	730	—	625	625	625	625	
					46 to 75	—	8-10d	5-10d	—	730	730	730	730	—	625	625	625	625	

Allowable Loads for Installation with Strong-Drive® SD Connector Screws

Min. Carried Member	Model No.	Dimensions		Min. Heff ⁴	Skew (Degree)	Fasteners			DF/SP Allowable Loads					SPF/HF Allowable Loads					Code Ref.
		W	H			Carrying Member		Carried Member	Uplift (160)	Floor (100)	Snow (115)	Roof (125)	Wind (160)	Uplift (160)	Floor (100)	Snow (115)	Roof (125)	Wind (160)	
						Top	Face												
TOP FLANGE INSTALLATION⁵																			
2x Truss	THASR/L29	1%	9%	5½"	22½°	4-SD #9x2½"	8-SD #9x2½"	7-SD #9x1½"	1085	2510	2665	2765	2790	935	1735	1835	1905	2140	
					23 to 45	4-SD #9x2½"	8-SD #9x2½"	4-SD #9x1½"	660	1995	2075	2125	2220	540	1400	1450	1485	1600	
					46 to 85	4-SD #9x2½"	8-SD #9x2½"	4-SD #9x1½"	535	1995	2075	2125	2220	460	1400	1450	1485	1600	
2-2x Truss	THASR/L29-2	3%	9%	5½"	22½°	4-SD #9x2½"	8-SD #9x2½"	8-SD #9x2½"	1450	2745	2745	2745	2745	1075	2360	2360	2360	2360	
					23 to 45	4-SD #9x2½"	8-SD #9x2½"	5-SD #9x2½"	530	1915	1915	1915	1915	455	1645	1645	1645	1645	
					46 to 85	4-SD #9x2½"	8-SD #9x2½"	5-SD #9x2½"	665	1530	1530	1530	1530	540	1315	1315	1315	1315	
4x Truss	THASR/L422	3%	22"	5½"	22½°	4-SD #9x2½"	4-SD #9x2½"	8-SD #9x2½"	—	1140	1140	1140	1140	—	980	980	980	980	
					23 to 45	4-SD #9x2½"	4-SD #9x2½"	5-SD #9x2½"	—	1065	1065	1065	1065	—	915	915	915	915	
					46 to 75	4-SD #9x2½"	4-SD #9x2½"	5-SD #9x2½"	—	870	870	870	870	—	750	750	750	750	
FACE MOUNT INSTALLATION																			
4x Truss	THASR/L422	3%	22"	5½"	22½°	—	8-SD #9x2½"	8-SD #9x2½"	—	1600	1720	1720	1720	—	895	1030	1120	1435	
					23 to 45	—	8-SD #9x2½"	5-SD #9x2½"	—	1330	1330	1330	1330	—	895	1030	1120	1145	
					46 to 75	—	8-SD #9x2½"	5-SD #9x2½"	—	1330	1330	1330	1330	—	895	1030	1120	1145	

1. Uplift loads have been increased for wind or earthquake loading with no further increase allowed. Reduce where other loads govern.
2. Wind (160) is a download rating.
3. Minimum carried member heel height shall be 4½".
4. Heff⁴ is the distance from the top of the hanger seat to the top of the carried member.
5. For tabulated top flange installation loads, the straps must be wrapped over the header a minimum of 2". Allowable downloads for the THASR/L29 and THASR/L29-2 with one or both straps installed vertically (with all holes filled) are 90% of the tabulated downloads for skews greater than 22½° and 85% of the tabulated downloads for 22½° skews. Allowable uplift capacities are 100% of the tabulated uplift load capacities.
6. Allowable downloads for 75°-85° skews with one or both straps installed vertically (with all holes filled) shall be limited to 75% of these loads.
7. **NAILS:** 10d = 0.148" dia. x 3" long, 10dx1½" = 0.148" dia. x 1½" long. See pages 22-23 for other nail sizes and information.
8. **SCREWS:** SD #9x1½" (model SD9112) = 0.131" dia. x 1½" long, SD #9x2½" (model SD9212) = 0.131" dia. x 2½" long.

UPDATED 03/27/15

W/WP/WM Plated Truss Top Flange Hangers

The W and WP hangers offer design flexibility and versatility supporting trusses off of wood or steel. WM hangers are designed for use on standard 8" grouted masonry block wall construction.

MATERIAL: W, WM—12 gauge top flange and stirrup,
WP—7 gauge top flange and 12 gauge stirrup

FINISH: Simpson Strong-Tie® gray paint; hot-dip galvanized available; specify HDG.

INSTALLATION: • Use all specified fasteners.

- Hangers may be welded to steel headers with 1/8" for W, and 3/16" for WP, by 1 1/2" fillet welds located at each end of the top flange. Weld-on applications produce maximum allowable load listed. Uplift loads do not apply to this application.
- Hangers can support multi-ply carried members; the individual members must be secured together to work as a single unit before installation into the hanger.
- **MID-WALL INSTALLATION:** Installed between blocks with duplex nails cast into grout with a minimum of one grouted course above and below the top flange and one #5 vertical rebar minimum 24" long in each adjacent cell.
- **TOP OF WALL INSTALLATION:** Install on top of wall to a grouted beam with masonry screws.

OPTIONS: For 4x2 trusses, specify "alternate nail pattern" (ANP) which relocates the nails to the bottom of the joist. See Hanger Options, pages 233-243 for hanger modifications.

CODES: See page 12 for Code Reference Key Chart.

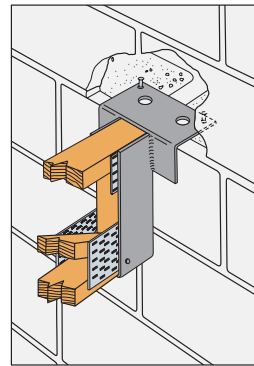
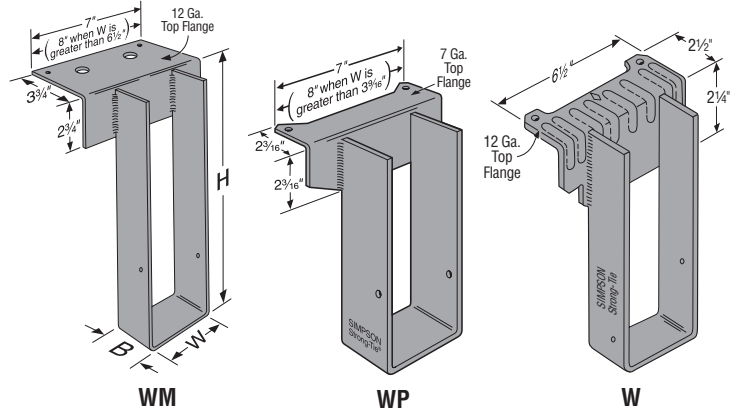

Typical WM Installation with Alternate Nail Pattern (ANP) for 4x2 Truss

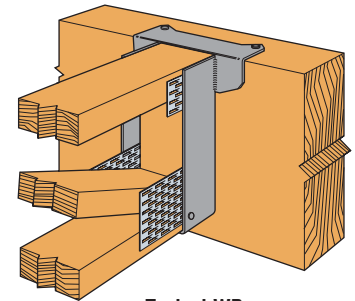

Typical WP Installation with Alternate Nail Pattern (ANP) for 4x2 Truss

Model	Nailer	Top Flange Nailing	Allowable Loads		
			DF/SP	SPF/HF	LSL
W	2x	2-10dx1 1/2	1600	1600	—
	2-2x	2-10d	1665	1665	—
	3x	2-16dx2 1/2	1765	1740	—
	4x	2-10d	2200	2200	—
WP	2x	2-10dx1 1/2	2525	2500	3375
	2-2x	2-10d	3255	3255	—
	3x	2-16dx2 1/2	3000	2510	3375
	4x	2-10d	3255	3255	—

NAILER TABLE

The table indicates the maximum allowable loads for W and WP hangers used on wood nailers. Nailers are wood members attached to the top of a steel I-beam, concrete or masonry wall.

These products are available with additional corrosion protection. Additional products on this page may also be available with this option, check with Simpson Strong-Tie for details.

W SERIES WITH VARIOUS HEADERS

Model	Joist		Fasteners			Allowable Loads Header Type								Code Ref.
	Width ⁴	Depth	Top	Face	Joist	Uplift (160)	LVL	PSL	LSL	DF/SP	SPF/HF	I-Joist	Masonry	
W	1 1/2 to 3 1/2	3 1/2 to 30	2-10dx1 1/2	—	2-10dx1 1/2	—	1635	1740	—	1600	1415	—	—	170
	1 1/2 to 3 1/2	3 1/2 to 30	2-10d	—	2-10dx1 1/2	—	2150	2020	—	2200	1435	—	—	I10, L11, F9
	1 1/2 to 3 1/2	3 1/2 to 30	2-16d	—	2-10dx1 1/2	—	2335	1950	2335	1765	1435	—	—	—
WM	1 1/2 to 7	3 1/2 to 30	2-16d DPLX	—	2-10dx1 1/2	—	—	—	—	—	—	—	4175	IL12, L16
WP	1 1/2 to 7	3 1/2 to 30	2-10dx1 1/2	—	2-10dx1 1/2	—	2865	3250	—	2500	2000	2030	—	170
	1 1/2 to 7	3 1/2 to 30	2-10d	—	2-10dx1 1/2	—	2525	3250	3650	3255	2600	—	—	I19, L14, F18
	1 1/2 to 7	3 1/2 to 30	2-16d	—	2-10dx1 1/2	—	3635	3320	3650	3255	2600	—	—	—

1. Uplift loads have been increased for wind or earthquake loading with no further increase allowed. Reduce where other loads govern.
2. WM hangers are limited based on joist bearing capacity for the specific wood species, up to the maximum test value of 4175 lbs. All headers are grouted masonry block.

3. Joist dimensions do not include truss plate thickness.
4. **NAILS:** 16d and 16d DPLX = 0.162" dia. x 3 1/2" long, 10d = 0.148" dia. x 3" long, 10dx1 1/2 = 0.148" dia. x 1 1/2" long. See pages 22-23 for other nail sizes and information.

Model No.	Ga	Dimensions				Fasteners		DF/SP Allowable Loads				SPF/HF Allowable Loads			
		W	Min. ³ H	B	TF	Carrying Member	Carried Member	Floor (100)	Snow (115)	Roof (125)	Wind (160)	Floor (100)	Snow (115)	Roof (125)	Wind (160)
W1.62x	12	1 1/8	4	2 1/2	2 1/2	2-10d	2-10dx1 1/2	2200	2200	2200	2200	1435	1435	1435	1435
WM1.62x	12	1 1/8	4	2	3 3/4	2-16d DPLX	2-10dx1 1/2	1890	1920	1940	1955	1445	1470	1485	1500
WP3.31x	12	3 3/16	4	2 1/2	2 3/16	2-10d	2-10d	3255	3255	3255	3255	2600	2600	2600	2600
WM3.31x	12	3 3/16	4	2	3 3/4	2-16d DPLX	2-10d	3635	3675	3700	3720	2765	2795	2820	2835
W3.62x	12	3 3/8	4	2 1/2	2 1/2	2-10d	2-10d	2200	2200	2200	2200	1435	1435	1435	1435
WP3.62x	12	3 3/8	4	2 1/2	2 3/16	2-10d	2-10d	3255	3255	3255	3255	2600	2600	2600	2600
WM3.62x	12	3 3/8	4	2	3 3/4	2-16d DPLX	2-10d	4175	4175	4175	4175	3190	3220	3240	3260
WP7.25x	12	7 1/4	4	2 1/2	2 3/16	2-10d	2-10d	3255	3255	3255	3255	2600	2600	2600	2600
WM7.25x	12	7 1/4	4	2	3 3/4	2-16d DPLX	2-10d	4175	4175	4175	4175	4175	4175	4175	4175

1. WM hangers are limited based on joist bearing capacity for the specific wood species, up to the maximum test value of 4175 lbs. All headers are grouted masonry block.
2. Wind (160) is a download rating.
3. "Min. H" is the minimum H dimension that may be ordered and desired H dimension should be specified. For hanger heights exceeding the joist height, the allowable load is 0.50 of the table load.
4. **NAILS:** 16d DPLX = 0.162" dia. x 3 1/2" long, 10d = 0.148" dia. x 3" long, 10dx1 1/2 = 0.148" dia. x 1 1/2" long. See pages 22-23 for other nail sizes and information.

LUS/MUS/HUS/HHUS/HGUS/HUSC Double Shear Joist Hangers



This product is preferable to similar connectors because of a) easier installation, b) higher loads, c) lower installed cost, or a combination of these features.

All hangers in this series have double shear nailing – an innovation that distributes the load through two points on each joist nail for greater strength. This allows for fewer nails, faster installation, and the use of all common nails for the same connection.

Double shear hangers range from the light capacity LUS hangers to the highest capacity HGUS hangers. For medium load truss applications, the MUS offers a lower cost alternative and easier installation than the HUS or THA hangers, while providing greater load capacity and bearing than the LUS.

MATERIAL: See tables below and on page 147.

FINISH: Galvanized. Some products available in stainless steel or ZMAX® coating; see Corrosion Information, pages 13-15.

INSTALLATION • Use all specified fasteners. See General Notes.

- Nails must be driven at an angle through the joist or truss into the header to achieve the table loads.
- Not designed for welded or nailer applications.

OPTIONS: • LUS and MUS hangers cannot be modified.

- HUS hangers available with the header flanges turned in for 2-2x (3 1/8") and 4x only, with no load reduction. See HUSC Concealed Flange illustration.
- Concealed flanges are not available for HGUS and HHUS.

- See Hanger Options, page 237, for sloped and/or skewed HHUS models.
- Other sizes available; consult your Simpson Strong-Tie representative.

CODES: See page 12 for Code Reference Key Chart.

These products are available with additional corrosion protection. Additional products on this page may also be available with this option, check with Simpson Strong-Tie for details.

These products are approved for installation with the Strong-Drive® SD Connector screw. See page 27 for more information.

Model No.	Min. Heel Height	Ga	Dimensions			Fasteners	
			W	H	B	Carrying Member	Carried Member
SINGLE 2x SIZES							
LUS24	2 1/2"	18	1 1/8"	3 1/2"	1 1/4"	4-10d	2-10d
LUS26	4 1/4"	18	1 1/8"	4 3/4"	1 3/4"	4-10d	4-10d
MUS26	4 1/16"	18	1 1/8"	5 3/16"	2	6-10d	6-10d
HUS26	4 3/8"	16	1 1/8"	5 1/2"	3	14-16d	6-16d
HGUS26	4 9/16"	12	1 1/8"	5 1/2"	5	20-16d	8-16d
LUS28	4 3/8"	18	1 1/8"	6 1/2"	1 3/4"	6-10d	4-10d
MUS28	6 1/16"	18	1 1/8"	6 3/16"	2	8-10d	8-10d
HUS28	6 1/2"	16	1 1/8"	7"	3	22-16d	8-16d
HGUS28	6 9/16"	12	1 1/8"	7 1/2"	5	36-16d	12-16d
LUS210	4 1/4"	18	1 1/8"	7 1/16"	1 1/4"	8-10d	4-10d
HUS210	8"	16	1 1/8"	9"	3	30-16d	10-16d

1. See table on page 147 for allowable loads.

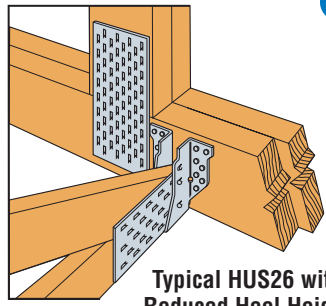
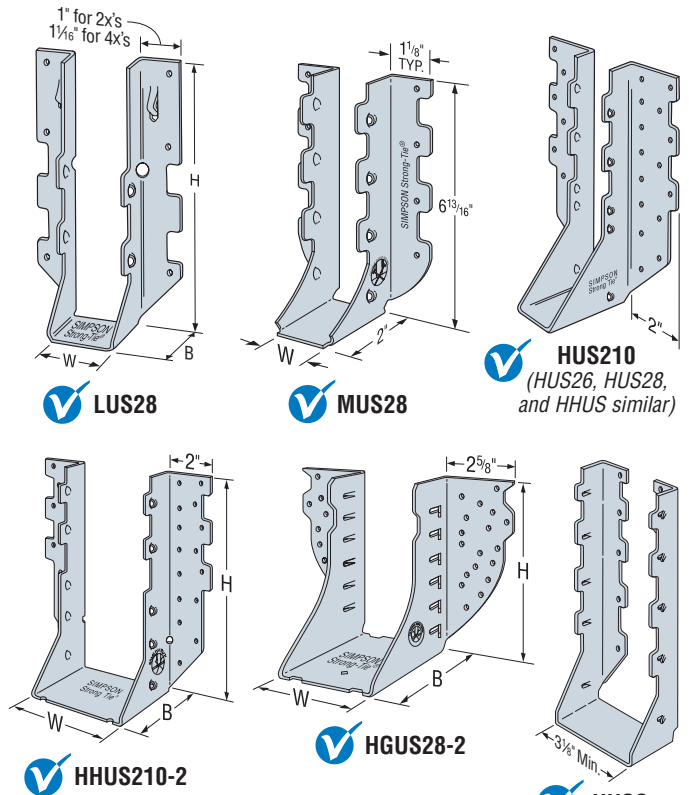

Typical HUS26 with Reduced Heel Height

(Truss Designer to provide fastener quantity for connecting multiple members together)

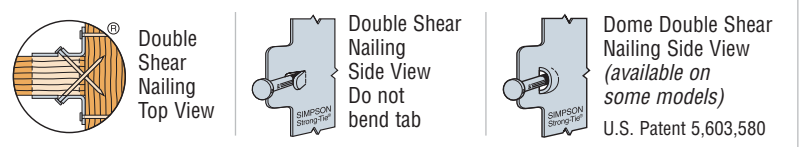

HUSC Concealed Flanges (not available for HHUS, HGUS and HUS2x)

Dome Double Shear Nailing Side View (available on some models)
U.S. Patent 5,603,580

Model No.	DF Allowable Loads					SP Allowable Loads					SPF/HF Allowable Loads					Code Ref.
	Uplift' (160)	Floor (100)	Snow (115)	Roof (125)	Wind (160)	Uplift' (160)	Floor (100)	Snow (115)	Roof (125)	Wind (160)	Uplift' (160)	Floor (100)	Snow (115)	Roof (125)	Wind (160)	
SINGLE 2x SIZES																
LUS24	490	670	765	825	1045	490	725	830	895	1135	420	575	655	705	895	I7, F6, L17
LUS26	1165	865	990	1070	1355	1165	940	1075	1165	1475	1005	740	845	915	1160	
MUS26	1090	1295	1480	1605	1825	1090	1410	1610	1745	1825	940	1110	1265	1370	1570	
HUS26	1550	2720	3095	3335	3335	1550	2950	3335	3335	3335	1335	2330	2650	2820	2865	
HGUS26	1765	4360	4885	5230	5390	1765	4725	5290	5390	5390	1520	3750	4200	4500	4635	
LUS28	1165	1100	1255	1360	1725	1165	1200	1365	1480	1835	1005	940	1075	1165	1475	I7, F6, L17
MUS28	1555	1730	1975	2140	2645	1555	1880	2150	2330	2645	1335	1475	1690	1830	2275	
HUS28	2000	3965	4120	4220	4335	2000	3790	3960	4070	4335	1720	2905	3035	3125	3435	
HGUS28	3015	6745	6970	7125	7275	3015	6460	6705	6870	7275	2595	4960	5160	5290	5745	
LUS210	1165	1340	1525	1650	2090	1165	1445	1660	1795	2270	1005	1145	1305	1415	1745	
HUS210	3000	4255	4445	4575	5020	3000	4105	4310	4450	4930	2580	3150	3315	3425	3815	

Note: For dimensions and fastener information, see table above. See table footnotes on page 147.

Plated Truss Connectors

C-C-2015 © 2015 SIMPSON STRONG-TIE COMPANY INC. PRINTED 12/14

FACE MOUNT HANGERS

These products are available with additional corrosion protection. Additional products on this page may also be available with this option, check with Simpson Strong-Tie for details.

These products are approved for installation with the Strong-Drive® SD Connector screw. See page 27 for more information.

Model No.	Min. Heel Height	Ga	Dimensions			Fasteners		DF/SP Allowable Loads					SPF/HF Allowable Loads					Code Ref.
			W	H	B	Carrying Member	Carried Member	Uplift ¹ (160)	Floor (100)	Snow (115)	Roof (125)	Wind (160)	Uplift ¹ (160)	Floor (100)	Snow (115)	Roof (125)	Wind (160)	
DOUBLE 2x SIZES																		
LUS24-2	2¼	18	3½	3½	2	4-16d	2-16d	440	800	910	985	1250	380	680	780	845	1070	I7, F6, L17
LUS26-2	4⅞	18	3½	4⅞	2	4-16d	4-16d	1165	1030	1180	1280	1625	1000	880	1010	1090	1385	
HHUS26-2	4⅞	14	3⅞	5⅞	3	14-16d	6-16d	1550	2785	3155	3405	4265	1335	2390	2710	2925	3665	I7, L17, F23
HGUS26-2	4⅞	12	3⅞	5⅞	4	20-16d	8-16d	2155	4355	4875	5230	5575	1855	3750	4200	4500	4795	
LUS28-2	4⅞	18	3½	7	2	6-16d	4-16d	1165	1315	1500	1625	2060	1000	1125	1285	1390	1765	I7, F6, L17
HHUS28-2	6⅞	14	3⅞	7¼	3	22-16d	8-16d	2000	4210	4770	5140	6440	1720	3615	4095	4415	5375	
HGUS28-2	6⅞	12	3⅞	7⅞	4	36-16d	12-16d	3235	7460	7460	7460	7460	2785	6415	6415	6415	6415	I7, L17, F23
LUS210-2	6⅞	18	3½	9	2	8-16d	6-16d	1745	1830	2090	2265	2870	1500	1565	1785	1935	2455	I7, F6, L17
HHUS210-2	8⅞	14	3⅞	8⅞	3	30-16d	10-16d	4000	5635	6380	6880	7165	3525	4835	5270	5380	5765	I7, L17, F23
HGUS210-2	8⅞	12	3⅞	9⅞	4	46-16d	16-16d	4095	9100	9100	9100	9100	3525	7465	7730	7825	7825	
TRIPLE 2x SIZES																		
HGUS26-3	4⅞	12	4⅞	5½	4	20-16d	8-16d	2155	4355	4875	5230	5575	1855	3750	4200	4500	4795	I7, L17, F23
HGUS28-3	6⅞	12	4⅞	7¼	4	36-16d	12-16d	3235	7460	7460	7460	7460	2785	6415	6415	6415	6415	
HGUS210-3	8⅞	12	4⅞	9¼	4	46-16d	16-16d	4095	9100	9100	9100	9100	3525	7825	7825	7825	7825	
HGUS212-3	10⅞	12	4⅞	10¾	4	56-16d	20-16d	5045	9600	9600	9600	9600	4335	8255	8255	8255	8255	
HGUS214-3	12⅞	12	4⅞	12¾	4	66-16d	22-16d	5515	10100	10100	10100	10100	4745	8685	8685	8685	8685	
QUADRUPLE 2x SIZES																		
HGUS26-4	5½	12	6⅞	5⅞	4	20-16d	8-16d	2155	4355	4875	5230	5575	1855	3750	4200	4500	4795	I7, L17, F23
HGUS28-4	7¼	12	6⅞	7⅞	4	36-16d	12-16d	3235	7460	7460	7460	7460	2785	6415	6415	6415	6415	
HGUS210-4	9¼	12	6⅞	9⅞	4	46-16d	16-16d	4095	9100	9100	9100	9100	3525	7825	7825	7825	7825	
HGUS212-4	10⅞	12	6⅞	10⅞	4	56-16d	20-16d	5045	9600	9600	9600	9600	4335	8255	8255	8255	8255	
HGUS214-4	12⅞	12	6⅞	12⅞	4	66-16d	22-16d	5515	10100	10100	10100	10100	4745	8685	8685	8685	8685	
4x SIZES																		
LUS46	4¾	18	3⅞	4¾	2	4-16d	4-16d	1165	1030	1180	1280	1625	1000	880	1010	1090	1385	I7, F6, L17
HGUS46	4⅞	12	3¾	4⅞	4	20-16d	8-16d	2155	4355	4875	5230	5575	1855	3750	4200	4500	4795	I7, L17, F23
HHUS46	4⅞	14	3¾	5⅞	3	14-16d	6-16d	1550	2790	3160	3410	4265	1335	2390	2710	2925	3665	
LUS48	4¾	18	3⅞	6¾	2	6-16d	4-16d	1165	1315	1500	1625	2060	1000	1125	1285	1390	1765	I7, F6, L17
HUS48	6⅞	14	3⅞	7	2	6-16d	6-16d	1550	1595	1815	1960	2470	1550	1365	1555	1680	2115	
HHUS48	6½	14	3¾	7⅞	3	22-16d	8-16d	2000	4215	4770	5150	6440	1720	3615	4095	4415	5335	I7, L17, F23
HGUS48	6⅞	12	3¾	7⅞	4	36-16d	12-16d	3235	7460	7460	7460	7460	2785	6415	6415	6415	6415	
LUS410	6¼	18	3⅞	8¾	2	8-16d	6-16d	1745	1830	2090	2265	2870	1500	1565	1785	1935	2455	I7, F6, L17
HHUS410	8¾	14	3¾	9	3	30-16d	10-16d	3745	5640	6385	6890	7165	3440	4835	5480	5910	6165	
HGUS410	8⅞	12	3¾	9⅞	4	46-16d	16-16d	4095	9100	9100	9100	9100	3525	7825	7825	7825	7825	I7, L17, F23
HGUS412	10⅞	12	3¾	10⅞	4	56-16d	20-16d	5045	9600	9600	9600	9600	4335	8255	8255	8255	8255	I7, L17
HGUS414	11⅞	12	3¾	12⅞	4	66-16d	22-16d	5515	10100	10100	10100	10100	4745	8685	8685	8685	8685	

- Uplift loads have been increased 60% for wind or earthquake loading with no further increase allowed. For normal loading applications such as cantilever construction refer to Simpson Strong-Tie® Connector Selector™ software or conservatively divide the uplift load by 1.6.
- Wind (160) is a download rating.
- Minimum heel height shown is required to achieve full table loads. For less than minimum heel height, see technical bulletin T-REDHEEL.
- Truss chord cross-grain tension may limit allowable loads in accordance with

ANSI/TPI 1-2007. Simpson Strong-Tie® Connector Selector™ Software includes the evaluation of cross-grain tension in its hanger allowable loads. For additional information, contact Simpson Strong-Tie.

- Loads shown are based on minimum of 2-ply 2x carrying member. With 3x carrying members, use 16d x 2½" nails into the header and 16d commons into the joist with no load reduction. With single 2x carrying members, use 10d x 1½" nails into the header and 10d commons into the joist, and reduce the load to 0.64 of the table value.
- NAILS:** 16d = 0.162" dia. x 3½" long. See pages 22-23 for other nail sizes and information.

HTU Face Mount Truss Hangers

The HTU face mount truss hangers have nail patterns designed specifically for shallow heel heights, so that full allowable loads (*with minimum nailing*) apply to heel heights as low as 3³/₈". Minimum and maximum nailing options provide solutions for varying heel heights and end conditions.

Alternate allowable loads are provided for gaps between the end of the truss and the carrying member up to 1/2" max. to allow for greater construction tolerances (*maximum gap for standard allowable loads is 1/8" per ASTM D1761 and D7147*). See technical bulletin T-HANGERGAPS for more information.

MATERIAL: 16 gauge

FINISH: Galvanized

INSTALLATION:

- Use all specified fasteners. See General Notes.
- Can be installed filling round holes only, or filling round and triangle holes for maximum values.
- See alternate installation for applications using the HTU26 on a 2x4 carrying member or HTU28 or HTU210 on a 2x6 carrying member for additional uplift capacity.

OPTIONS: • HTU may be skewed up to 67¹/₂%.

See Hanger Options on pages 233-243 for allowable loads.

CODES: See page 12 for Code Reference Key Chart.

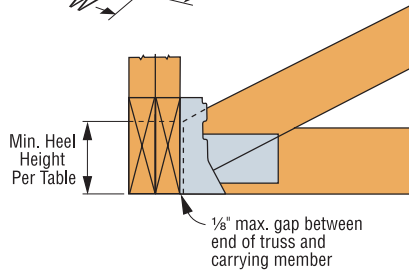
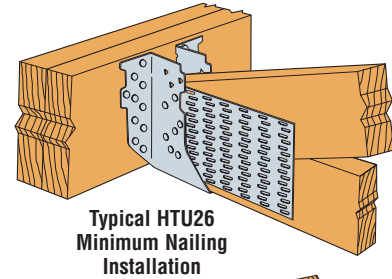
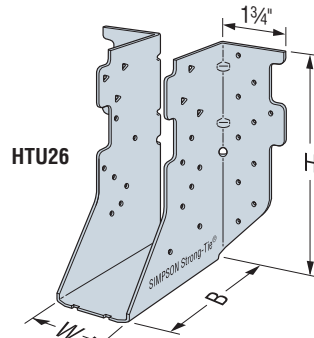

HTU Installation for Standard Allowable Loads
(For 1/2" maximum gap, use Alternate Allowable Loads.)

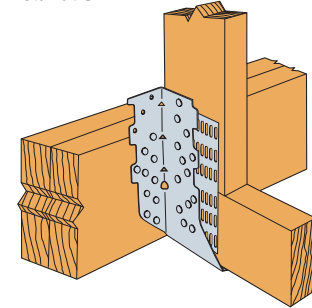

Alternate Installation - HTU28 installed on 2x6 carrying member (HTU210 similar)

Standard Allowable Loads (1/8" Maximum Hanger Gap)

Model No.	Min. Heel Height	Dimensions			Fasteners		DF/SP Allowable Loads					SPF/HF Allowable Loads					Code Ref.
		W	H	B	Carrying Member	Carried Member	Uplift (160)	Floor (100)	Snow (115)	Roof (125)	Wind (160)	Uplift (160)	Floor (100)	Snow (115)	Roof (125)	Wind (160)	
SINGLE 2x SIZES																	
HTU26	3 ³ / ₈ "	1 ¹ / ₂ "	5 ¹ / ₁₆ "	3 ¹ / ₂ "	20-16d	11-10dx1 ¹ / ₂ "	730	2940	3045	3045	3045	630	1920	1920	1920	1920	17, L17, F22
HTU26 (Min)	3 ³ / ₈ "	1 ¹ / ₂ "	5 ¹ / ₁₆ "	3 ¹ / ₂ "	20-16d	14-10dx1 ¹ / ₂ "	1250	2940	3200	3200	3200	1075	2015	2015	2015	2015	
HTU26 (Max)	5 ¹ / ₂ "	1 ¹ / ₂ "	5 ¹ / ₁₆ "	3 ¹ / ₂ "	20-16d	20-10dx1 ¹ / ₂ "	1555	2940	3340	3600	4010	1335	2530	2870	3095	3450	
HTU28 (Min)	3 ³ / ₈ "	1 ¹ / ₂ "	7 ¹ / ₁₆ "	3 ¹ / ₂ "	26-16d	14-10dx1 ¹ / ₂ "	1235	3820	3895	3895	3895	1060	2920	2920	2920	2920	
HTU28 (Max)	7 ¹ / ₄ "	1 ¹ / ₂ "	7 ¹ / ₁₆ "	3 ¹ / ₂ "	26-16d	26-10dx1 ¹ / ₂ "	2140	3820	4340	4680	5435	1840	3285	3730	4025	4675	
HTU210 (Min)	3 ³ / ₈ "	1 ¹ / ₂ "	9 ¹ / ₁₆ "	3 ¹ / ₂ "	32-16d	14-10dx1 ¹ / ₂ "	1330	4355	4355	4355	4355	1145	3265	3265	3265	3265	
HTU210 (Max)	9 ¹ / ₄ "	1 ¹ / ₂ "	9 ¹ / ₁₆ "	3 ¹ / ₂ "	32-16d	32-10dx1 ¹ / ₂ "	3315	4705	5345	5760	5995	2850	4045	4595	4955	5155	
DOUBLE 2x SIZES																	
HTU26-2 (Min)	3 ³ / ₈ "	3 ³ / ₈ "	5 ¹ / ₁₆ "	3 ¹ / ₂ "	20-16d	14-10d	1515	2940	3340	3600	3910	1305	2465	2465	2465	2465	17, L17, F22
HTU26-2 (Max)	5 ¹ / ₂ "	3 ³ / ₈ "	5 ¹ / ₁₆ "	3 ¹ / ₂ "	20-16d	20-10d	2175	2940	3340	3600	4485	1870	2530	2870	3095	3855	
HTU28-2 (Min)	3 ³ / ₈ "	3 ³ / ₈ "	7 ¹ / ₁₆ "	3 ¹ / ₂ "	26-16d	14-10d	1530	3820	4310	4310	4310	1315	3235	3235	3235	3235	
HTU28-2 (Max)	7 ¹ / ₄ "	3 ³ / ₈ "	7 ¹ / ₁₆ "	3 ¹ / ₂ "	26-16d	26-10d	3485	3820	4340	4680	5850	2995	3285	3730	4025	5030	
HTU210-2 (Min)	3 ³ / ₈ "	3 ³ / ₈ "	9 ¹ / ₁₆ "	3 ¹ / ₂ "	32-16d	14-10d	1755	4705	4815	4815	4815	1510	3610	3610	3610	3610	
HTU210-2 (Max)	9 ¹ / ₄ "	3 ³ / ₈ "	9 ¹ / ₁₆ "	3 ¹ / ₂ "	32-16d	32-10d	4110	4705	5345	5760	7200	3535	4045	4595	4955	6190	

1. The maximum hanger gap is measured between the joist (*or truss*) end and the carrying member.
2. Minimum heel heights required for full table loads are based on a minimum 2/12 pitch.
3. Uplift has been increased for wind or earthquake loading with no further increase allowed; reduce where other loads govern.
4. Wind (160) is a download rating.
5. For hanger gaps between 1/8" and 1/2", use the Alternate Allowable Loads.
6. Truss chord cross-grain tension may limit allowable loads in accordance with

- ANSI/TPI 1-2007. Simpson Strong-Tie® Connector Selector™ Software includes the evaluation of cross-grain tension in its hanger allowable loads. For additional information, contact Simpson Strong-Tie.
7. Loads shown are based on a minimum 2-ply 2x carrying member. For single 2x carrying members, use N10 (10dx1¹/₂") nails into the header and reduce the allowable download to 0.70 of the table value. The allowable uplift is 100% of the table load.
 8. **NAILS:** 16d = 0.162" dia. x 3¹/₂" long, 10d = 0.148" dia. x 3" long, 10dx1¹/₂" = 0.148" dia. x 1¹/₂" long. See pages 22-23 for other nail sizes and information.

Alternate Installation Table for 2x4 and 2x6 Carrying Member

Model No.	Min. Heel Height (in.)	Minimum Carrying Member	Fasteners		DF/SP Allowable Loads					SPF/HF Allowable Loads					Code Ref.
			Carrying Member	Carried Member	Uplift (160)	Floor (100)	Snow (115)	Roof (125)	Wind (160)	Uplift (160)	Floor (100)	Snow (115)	Roof (125)	Wind (160)	
HTU26 (Min)	3 ³ / ₈ "	2-2x4	10-16d	14-10dx1 ¹ / ₂ "	925	1470	1670	1800	2040	795	1265	1435	1550	1755	17, L17, F22
HTU26 (Max)	5 ¹ / ₂ "	2-2x4	10-16d	20-10dx1 ¹ / ₂ "	1310	1470	1670	1800	2250	1125	1265	1435	1550	1935	
HTU28 (Max)	7 ¹ / ₄ "	2-2x6	20-16d	26-10dx1 ¹ / ₂ "	1970	2940	3340	3600	3905	1695	2530	2870	3095	3360	
HTU210 (Max)	9 ¹ / ₄ "	2-2x6	20-16d	32-10dx1 ¹ / ₂ "	2760	2940	3340	3600	3905	2375	2530	2870	3095	3360	

1. See table above for dimensions and additional footnotes.
2. Maximum hanger gap for the alternate installation is 1/2".
3. Wind (160) is a download rating.
4. **NAILS:** 16d = 0.162" dia. x 3¹/₂" long, 10dx1¹/₂" = 0.148" dia. x 1¹/₂" long. See pages 22-23 for other nail sizes and information.

HTU Face Mount Truss Hangers

Alternate Allowable Loads (1/2" Maximum Hanger Gap)

Model No.	Min. Heel Height	Dimensions			Fasteners		DF/SP Allowable Loads					SPF/HF Allowable Loads					Code Ref.
		W	H	B	Carrying Member	Carried Member	Uplift (160)	Floor (100)	Snow (115)	Roof (125)	Wind (160)	Uplift (160)	Floor (100)	Snow (115)	Roof (125)	Wind (160)	
SINGLE 2x SIZES																	
HTU26 ^s	3 1/2	1 1/8	5 1/8	3 1/2	20-16d	11-10dx1 1/2	670	2735	2735	2735	2735	575	1725	1725	1725	1725	17, L17, F22
HTU26 (Min)	3 3/8	1 1/8	5 1/8	3 1/2	20-16d	14-10dx1 1/2	1175	2940	3100	3100	3100	1010	1955	1955	1955	1955	
HTU26 (Max)	5 1/2	1 1/8	5 1/8	3 1/2	20-16d	20-10dx1 1/2	1215	2940	3340	3600	3760	1045	2370	2370	2370	2370	
HTU28 (Min)	3 3/8	1 1/8	7 1/8	3 1/2	26-16d	14-10dx1 1/2	1125	3770	3770	3770	3770	970	2825	2825	2825	2825	
HTU28 (Max)	7 1/4	1 1/8	7 1/8	3 1/2	26-16d	26-10dx1 1/2	1920	3820	4340	4680	5015	1695	3285	3730	3765	3765	
HTU210 (Min)	3 3/8	1 1/8	9 1/8	3 1/2	32-16d	14-10dx1 1/2	1250	3600	3600	3600	3600	1075	2700	2700	2700	2700	
HTU210 (Max)	9 1/4	1 1/8	9 1/8	3 1/2	32-16d	32-10dx1 1/2	3255	4705	5020	5020	5020	2800	3765	3765	3765	3765	
DOUBLE 2x SIZES																	
HTU26-2 (Min)	3 3/8	3 3/8	5 1/8	3 1/2	20-16d	14-10d	1515	2940	3340	3500	3500	1305	2205	2205	2205	2205	17, L17, F22
HTU26-2 (Max)	5 1/2	3 3/8	5 1/8	3 1/2	20-16d	20-10d	1910	2940	3340	3500	3500	1645	2205	2205	2205	2205	
HTU28-2 (Min)	3 3/8	3 3/8	7 1/8	3 1/2	26-16d	14-10d	1490	3820	3980	3980	3980	1280	2985	2985	2985	2985	
HTU28-2 (Max)	7 1/4	3 3/8	7 1/8	3 1/2	26-16d	26-10d	3035	3820	4340	4680	5555	2610	3285	3730	4025	4165	
HTU210-2 (Min)	3 3/8	3 3/8	9 1/8	3 1/2	32-16d	14-10d	1755	4255	4255	4255	4255	1510	3190	3190	3190	3190	
HTU210-2 (Max)	9 1/4	3 3/8	9 1/8	3 1/2	32-16d	32-10d	3855	4705	5345	5760	6470	3315	4045	4595	4855	4855	

See table footnotes on page 148.

HGUQ Multi-Ply Girder Truss Hangers

HGUQ hangers provide similar capacities as HGUS double shear hangers, but they use Simpson Strong-Tie® Strong-Drive® SDS Heavy-Duty Connector screws instead of nails for faster and easier installation. In addition, the Strong-Drive SDS Heavy-Duty Connector screws help transfer the load between the plies of the supporting girder when they penetrate all plies.

MATERIAL: 12 gauge **FINISH:** Galvanized. **HGD available.** Contact Simpson Strong-Tie.

INSTALLATION: • Use all specified fasteners. See General Notes.

- Simpson Strong-Tie Strong-Drive SDS Heavy-Duty Connector screws supplied.
- Not designed for welded or nailer applications.
- The thickness of the supporting girder must be equal to or greater than the screw length. For applications where the length of the supplied screws exceeds the thickness of the supporting girder, 3" or 4 1/2" screws may be substituted for the longer length screws with no load reduction, or a shim block may be used as approved by the Designer.

OPTIONS: These hangers cannot be modified.

CODES: See page 12 for Code Reference Key Chart.

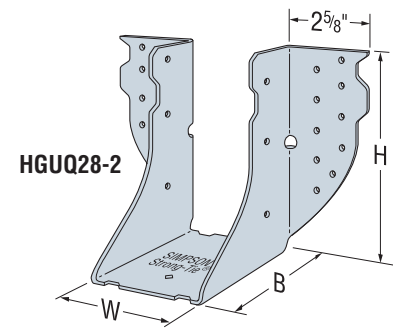

These products are available with additional corrosion protection. Additional products on this page may also be available with this option, check with Simpson Strong-Tie for details.

Model No.	Ga	Dimensions			SDS Fasteners		DF/SP Allowable Loads					SPF/HF Allowable Loads					Code Ref.
		W	H	B	Carrying Member	Carried Member	Uplift ¹ (160)	Floor (100)	Snow (115)	Roof (125)	Wind (160)	Uplift ¹ (160)	Floor (100)	Snow (115)	Roof (125)	Wind (160)	
DOUBLE 2x SIZES																	
HGUQ26-2-SDS3	12	3 3/8	5 1/8	4	(12) 1/4"x3"	(4) 1/4"x3"	1635	5040	5565	5565	5565	1175	3630	4005	4005	4005	F23
HGUQ28-2-SDS3	12	3 3/8	7 1/8	4	(20) 1/4"x3"	(6) 1/4"x3"	2565	7330	7330	7330	7330	1845	5280	5280	5280	5280	
HGUQ210-2-SDS3	12	3 3/8	9 1/8	4	(28) 1/4"x3"	(8) 1/4"x3"	3440	7415	7415	7415	7415	2475	5340	5340	5340	5340	
TRIPLE 2x SIZES																	
HGUQ26-3-SDS4.5	12	4 1/8	5 1/2	4	(12) 1/4"x4 1/2"	(4) 1/4"x4 1/2"	1635	5040	5165	5165	5165	1175	3630	3720	3720	3720	F23
HGUQ28-3-SDS4.5	12	4 1/8	7 1/4	4	(20) 1/4"x4 1/2"	(6) 1/4"x4 1/2"	2565	8400	9175	9175	9175	1845	6050	6605	6605	6605	
HGUQ210-3-SDS4.5	12	4 1/8	9 1/4	4	(28) 1/4"x4 1/2"	(8) 1/4"x4 1/2"	3440	9745	9745	9745	9745	2475	7015	7015	7015	7015	
QUADRUPLE 2x SIZES																	
HGUQ26-4-SDS6	12	6 3/8	5 7/8	4	(12) 1/4"x6"	(4) 1/4"x6"	2375	5040	5165	5165	5165	1710	3630	3720	3720	3720	F23
HGUQ28-4-SDS6	12	6 3/8	7 3/8	4	(20) 1/4"x6"	(6) 1/4"x6"	4020	8400	8860	8860	8860	2890	6050	6380	6380	6380	
HGUQ210-4-SDS6	12	6 3/8	9 3/8	4	(28) 1/4"x6"	(8) 1/4"x6"	4170	10260	10260	10260	10260	3000	7385	7385	7385	7385	
4x SIZES																	
HGUQ46-SDS3	12	3 3/8	4 7/8	4	(12) 1/4"x3"	(4) 1/4"x3"	1635	5040	5165	5165	5165	1175	3630	3720	3720	3720	F23
HGUQ48-SDS3	12	3 3/8	6 3/8	4	(20) 1/4"x3"	(6) 1/4"x3"	2565	7330	7330	7330	7330	1845	5280	5280	5280	5280	
HGUQ410-SDS3	12	3 3/8	8 3/8	4	(28) 1/4"x3"	(8) 1/4"x3"	3440	7415	7415	7415	7415	2475	5340	5340	5340	5340	

- Uplift loads have been increased for wind or earthquake loading with no further increase allowed. Reduce where other loads govern.
- Wind (160) is a download rating.
- Truss chord cross-grain tension may limit allowable loads in accordance with ANSI/TPI 1-2007. Simpson Strong-Tie® Connector Selector™ Software includes the evaluation of cross-grain tension in its hanger allowable loads. For additional information, contact Simpson Strong-Tie.
- Simpson Strong-Tie® Strong-Drive® SDS Heavy-Duty Connector screws are permitted to be installed through metal truss plates as approved by the Truss Designer, provided the requirements of ANSI/TPI 1-2007 Sections 7.5.3.4 and 8.9.2 are met (pre-drilling required through the plate using a maximum of 3/32" bit).
- Strong-Drive SDS Heavy-Duty Connector screws that penetrate all plies of the supporting girder (screws must penetrate a minimum of 1" into the last truss ply) may also be used to transfer the load through all the plies of the supporting girder. When Strong-Drive SDS Heavy-Duty Connector screws do not penetrate all plies of the supporting girder truss, supplemental Strong-Drive SDS Heavy-Duty Connector screws at the hanger locations may be required to transfer the load to the truss plies not penetrated by the face fasteners, as determined by the Designer.
- The supporting girder truss must have adequate thickness to accommodate the screw length, so that the screw does not protrude out the back of the girder. 3" or 4 1/2" long Strong-Drive SDS Heavy-Duty Connector screws may be substituted for the longer Strong-Drive SDS Heavy-Duty Connector screws with no load reduction.
- For installations to LSL, use the DF/SP table loads.

HHSUQ Heavy Severe Skew Truss Hanger

The HHSUQ is a high-load, face-mount, truss-to-truss hanger designed to accommodate severe skews (45°-84°) for hip trusses, enabling a greater range of installation applications. Fastening the HHSUQ with Simpson Strong-Tie® Strong-Drive® SDS Heavy-Duty Connector screws makes installation fast and easy, while eliminating the inconvenience of bolted applications.

MATERIAL: Back plate—3 gauge; stirrup—7 gauge

FINISH: Simpson Strong-Tie® gray paint

INSTALLATION: • Use all specified fasteners. See General Notes.

- The joist/truss end may be square cut or bevel cut. 3/8" minimum heel height.
- Strong-Drive SDS Heavy-Duty Connector screws supplied for all round holes.
- All multiple members must be fastened together to act as a single unit.

TO ORDER: Left or right skew must be specified.

CODES: See page 12 for Code Reference Key Chart.

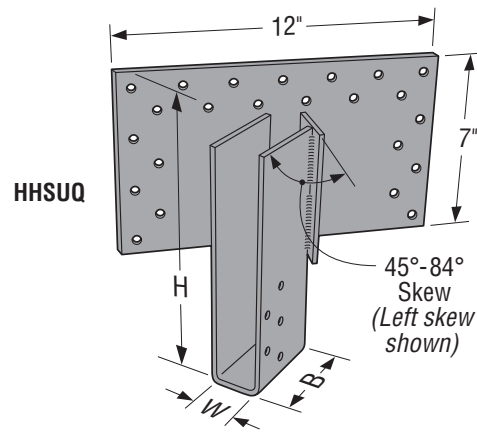

Plated Truss Connectors

Model Number	Dimensions (in.)			SDS Fasteners		DF/SP Allowable Loads				SPF/HF Allowable Loads				Code Ref.
	W	H	B	Face	Joist	Uplift (160)	Floor (100)	Snow (115)	Roof (125)	Uplift (160)	Floor (100)	Snow (115)	Roof (125)	
HHSUQ28-SDS	1 5/8	7 1/4	3 1/2	23 - 1/4"x3"	5 - 1/4"x1 1/2"	1170	4215	4405	4530	1005	3025	3160	3250	160
HHSUQ28-2-SDS	3 3/16	7 1/4	3 1/2	23 - 1/4"x3"	5 - 1/4"x3"	1250	5065	5065	5065	1075	5065	5065	5065	
HHSUQ210-SDS	1 5/8	9 1/4	3 1/2	23 - 1/4"x3"	5 - 1/4"x1 1/2"	1170	4215	4405	4530	1005	3025	3160	3250	
HHSUQ210-2-SDS	3 3/16	9 1/4	3 1/2	23 - 1/4"x3"	5 - 1/4"x3"	1250	5065	5065	5065	1075	5065	5065	5065	
HHSUQ212-SDS	1 5/8	11 1/4	3 1/2	23 - 1/4"x3"	5 - 1/4"x1 1/2"	1170	4215	4405	4530	1005	3025	3160	3250	
HHSUQ212-2-SDS	3 3/16	11 1/4	3 1/2	23 - 1/4"x3"	5 - 1/4"x3"	1250	5065	5065	5065	1075	5065	5065	5065	
HHSUQ214-SDS	1 5/8	13 1/4	3 1/2	23 - 1/4"x3"	5 - 1/4"x1 1/2"	1170	4215	4405	4530	1005	3025	3160	3250	
HHSUQ214-2-SDS	3 3/16	13 1/4	3 1/2	23 - 1/4"x3"	5 - 1/4"x3"	1250	5065	5065	5065	1075	5065	5065	5065	
HHSUQ48-SDS	3 5/8	7 1/4	3 1/2	23 - 1/4"x3"	5 - 1/4"x3"	1250	5065	5065	5065	1075	5065	5065	5065	
HHSUQ410-SDS	3 5/8	9 1/4	3 1/2	23 - 1/4"x3"	5 - 1/4"x3"	1250	5065	5065	5065	1075	5065	5065	5065	
HHSUQ412-SDS	3 5/8	11 1/4	3 1/2	23 - 1/4"x3"	5 - 1/4"x3"	1250	5065	5065	5065	1075	5065	5065	5065	
HHSUQ414-SDS	3 5/8	13 1/4	3 1/2	23 - 1/4"x3"	5 - 1/4"x3"	1250	5065	5065	5065	1075	5065	5065	5065	
HHSUQ1.81/7-SDS	1 13/16	7 1/4	3 1/2	23 - 1/4"x3"	5 - 1/4"x1 1/2"	1170	5065	5065	5065	1005	5065	5065	5065	
HHSUQ1.81/9-SDS	1 13/16	9 1/2	3 1/2	23 - 1/4"x3"	5 - 1/4"x1 1/2"	1170	5065	5065	5065	1005	5065	5065	5065	
HHSUQ1.81/11-SDS	1 13/16	11 5/8	3 1/2	23 - 1/4"x3"	5 - 1/4"x1 1/2"	1170	5065	5065	5065	1005	5065	5065	5065	
HHSUQ1.81/14-SDS	1 13/16	13 1/4	3 1/2	23 - 1/4"x3"	5 - 1/4"x1 1/2"	1170	5065	5065	5065	1005	5065	5065	5065	

1. Allowable Uplift loads have been increased for wind or earthquake loading with no further increase allowed; reduce where other loads govern.
2. Strong-Drive® SDS Heavy-Duty Connector screws that penetrate all plies of the supporting girder (screws must penetrate a minimum of 1" into the last truss ply) may also be used to transfer the load through all the plies of the supporting girder. When Strong-Drive SDS Heavy-Duty Connector screws do not penetrate all plies of the supporting girder truss, supplemental Strong-Drive SDS Heavy-Duty Connector screws at the hanger locations may be required to transfer the load to the truss plies not penetrated by the face fasteners, as determined by the Designer. 3" long Strong-Drive SDS Heavy-Duty Connector screws into face may be replaced with 4 1/2" or 6" long Strong-Drive SDS Heavy-Duty Connector screws with no load reduction.
3. Loads shown are based on a minimum 2-ply 2x8 carrying member. For single 2x carrying members, replace 3" long Strong-Drive SDS Heavy-Duty Connector screws face fasteners with 1 1/2" long Strong-Drive SDS Heavy-Duty Connector screws and

4. reduce the allowable download to 2630 lbs. for DF/SP and 1895 lbs. for SPF/HF. The tabulated allowable uplift load is not reduced.
4. Girders must be adequately laterally braced to prevent excessive displacement due to secondary torsional stresses (Ref ANSI/TPI 1-2007 Section 7.5.3.5).
5. Truss chord cross-grain tension may limit allowable loads. Designer to refer to ANSI/TPI Section 7.5.3.2 for connection details, limitations, and reductions.
6. Simpson Strong-Tie® Strong-Drive SDS Heavy-Duty Connector screws are permitted to be installed through metal truss plates as approved by the Truss Designer, provided the requirements of ANSI/TPI 1-2007 Sections 7.5.3.4 and 8.9.2 are met (pre-drilling required through the plate using a maximum of 5/32" bit).
7. For installations into LSL or PSL, use DF/SP table loads.

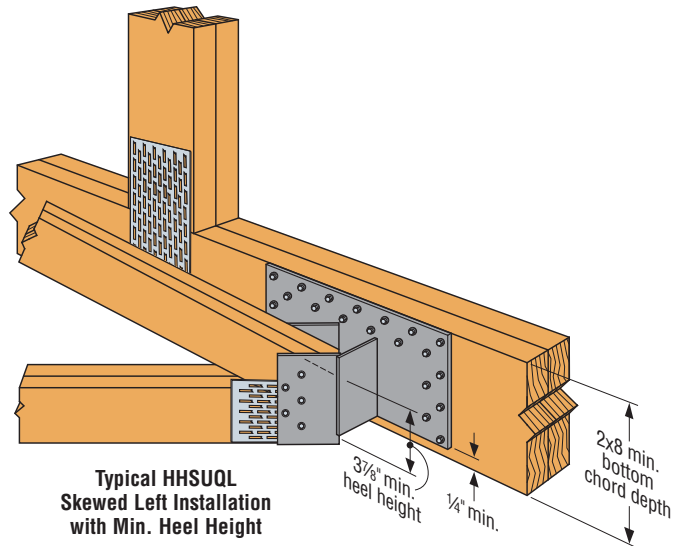
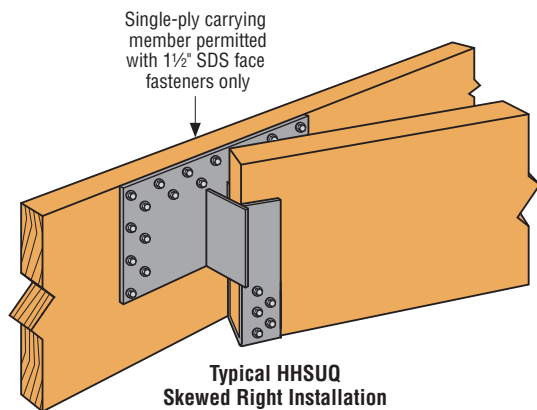

THAR/L422 Skewed Truss Hangers

Designed for 4x2 floor trusses and 4x beams, the THAR/L422 has a standard skew of 45°. Straps must be bent for top flange installation. PAN nailing helps eliminate splitting of 4x2 truss bottom chords.

MATERIAL: 16 gauge

FINISH: Galvanized

INSTALLATION: • Use all specified fasteners.

See General Notes.

- Straps must be field-formed over the header a minimum of 2½".
- Minimum and maximum nailing configurations available – see table for nailing requirements.

CODES: See page 12 for Code Reference Key Chart.

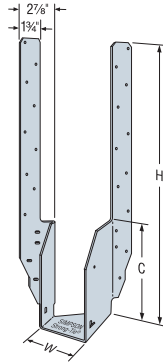

THAL422

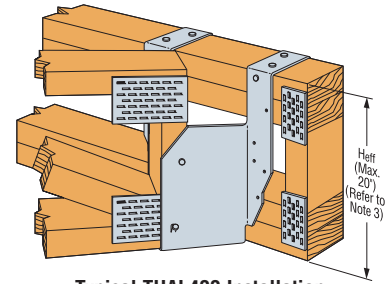

Typical THAL422 Installation with Minimum Nailing on a Floor Truss with Double 4x2 Top Chord

Model No.	Ga	Dimensions (in.)			Minimum Top Chord on Carrying Member	Effective Height H _{eff} ³	Fasteners				DF/SP Allowable Loads				SPF/HF Allowable Loads				Code Ref.
		W	H	C			Carrying Member		Carried Member		Uplift (160)	Floor (100)	Snow (115)	Roof (125)	Uplift (160)	Floor (100)	Snow (115)	Roof (125)	
							Top	Face	Straight	Slant									
THAR/L422 (Min)	16	3%	22%	8	Single 4x2	9 min.	4-10dx1½	2-10dx1½	1-10dx1½	2-10dx1½	—	880	880	880	—	755	755	755	18, L15, F7
						9 to 12	4-10d	2-10d	1-10d	2-10dx1½	—	1525	1525	1525	—	1315	1315	1315	
> 12	—	1090	1090	1090	—		935	935	935										
THAR/L422 (Max)	16	3%	22%	8	Double 4x2	9 min.	4-10d	8-10d	1-10d	2-10dx1½	310	1675	1675	1675	265	1440	1440	1440	

1. Uplift has been increased for wind or earthquake loading with no further increase allowed; reduce where other loads govern.
2. Roof loads are 125% of floor loads unless limited by other criteria. Floor loads may be adjusted for load durations according to the code provided they do not exceed those in the roof column.

3. Where the top of the carried member is flush with the top of the carrying member, H_{eff} is equal to the depth of the carried member. Otherwise, H_{eff} shall be measured from the top of the bearing seat to the top of the carrying member.
4. **NAILS:** 10d = 0.148" dia. x 3" long, 10dx1½ = 0.148" dia. x 1½" long. See pages 22-23 for other nail sizes and information.

LTHMA Multiple Truss Hangers

Light capacity hanger designed to carry 2 or 3 trusses in a terminal hip installation.

MATERIAL: 16 gauge

FINISH: Galvanized

INSTALLATION: • Use all specified fasteners. See General Notes.

- The total load must be symmetrically distributed about the centerline to avoid eccentric loading of the connector.
- Fill round holes for girder trusses with 2x4 bottom chords.
- Fill round and triangle holes for girder trusses with 2x6 bottom chords.

CODES: See page 12 for Code Reference Key Chart.

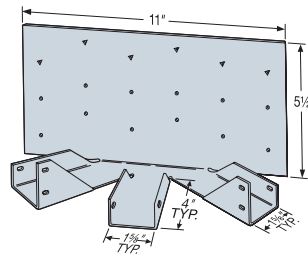

LTHMA

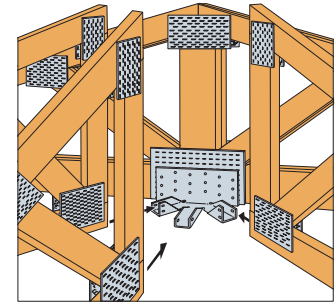

Typical LTHMA Installation

Model No.	Header	Fasteners			DF/SP Allowable Loads												Code Ref.
		Header	Hips (Total)	Jack	Uplift (160)			Floor (100)			Snow (115)			Roof (125/160)			
					Hip	Jack	Total	Hip	Jack	Total	Hip	Jack	Total	Hip	Jack	Total	
LTHMA	1 ply 2x4	12-10dx1½	6-10dx1½	2-10dx1½	55	20	130	485	110	1080	540	125	1205	540	125	1205	IL15, F12
	2 ply 2x4	12-10d	6-10dx1½	2-10dx1½	55	20	130	600	130	1330	675	150	1500	675	150	1500	
	1 ply 2x6	18-10dx1½	6-10dx1½	2-10dx1½	55	20	130	635	140	1410	635	140	1410	635	140	1410	
	2 ply 2x6	18-10d	6-10dx1½	2-10dx1½	85	25	195	900	200	2000	1035	230	2300	1050	240	2340	

Model No.	Header	Fasteners			SPF/HF Allowable Loads												Code Ref.
		Header	Hips (Total)	Jack	Uplift (160)			Floor (100)			Snow (115)			Roof (125/160)			
					Hip	Jack	Total	Hip	Jack	Total	Hip	Jack	Total	Hip	Jack	Total	
LTHMA	1 ply 2x4	12-10dx1½	6-10dx1½	2-10dx1½	50	10	110	440	55	935	485	65	1035	485	65	1035	IL15, F12
	2 ply 2x4	12-10d	6-10dx1½	2-10dx1½	50	10	110	540	70	1150	570	75	1215	570	75	1215	
	1 ply 2x6	18-10dx1½	6-10dx1½	2-10dx1½	50	10	110	570	75	1215	570	75	1215	570	75	1215	
	2 ply 2x6	18-10d	6-10dx1½	2-10dx1½	85	15	185	815	100	1730	930	125	1985	940	120	2000	

1. Allowable loads have been increased for wind or earthquake loading with no further increase allowed; reduce where other loads govern.
2. Hip loads are for each hip.
3. Load distribution is 45% for each hip and 10% for jack. Other hip/jack load distributions are allowed if the sum of all three carried members does not exceed the total load and the hip members are equally loaded.

4. Truss chord cross-grain tension may limit allowable loads in accordance with ANSI/TPI 1-2007. Simpson Strong-Tie® Connector Selector™ Software includes the evaluation of cross-grain tension in its hanger allowable loads. For additional information, contact Simpson Strong-Tie.
5. **NAILS:** 10d = 0.148" dia. x 3" long, 10dx1½ = 0.148" dia. x 1½" long. See pages 22-23 for other nail sizes and information.

THJU Truss Hip/Jack Hanger

The THJU hip/jack hanger offers the most flexibility and ease of installation without sacrificing performance. The U-shaped hanger works for right and left hand hips and can be ordered to fit a range of hip skews (up to 67½ degrees) as well as various single and 2-ply hip/jack combinations. Also can be installed before or after the hip and jack.

THJU26 is sized for the standard hip/jack combination with a 45-degree left or right-hand hip. The wide seat of THJU26-W accommodates a 2-ply hip and 2-ply jack combination with a 45 degree maximum hip skew, or a standard single-ply hip/jack configuration with a maximum 67½-degree hip skew. Intermediate seat widths are available for other hip/jack or hip/hip combinations.

MATERIAL: 12 gauge

FINISH: Galvanized

INSTALLATION: • Use all specified fasteners.
See General Notes.

OPTIONS:

- THJU is available in intermediate seat widths between 5½" (THJU26 width) and 8½" (THJU26-W width) with no load reduction.
- For double hip installation, divide the total allowable load by 2 to determine the allowable load for each hip. Order as THJU26X and specify width; see table page 237 for reference.

CODES: See page 12 for Code Reference Key Chart.

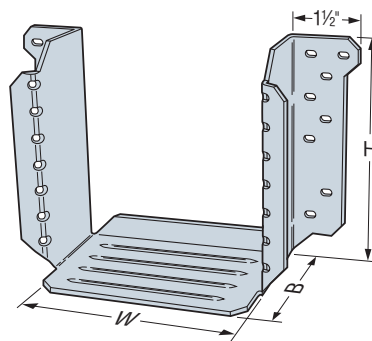

THJU26

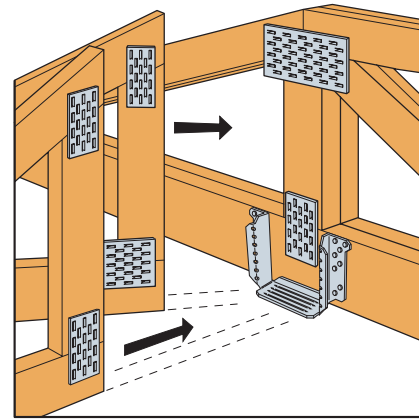

Typical THJU26 Installation

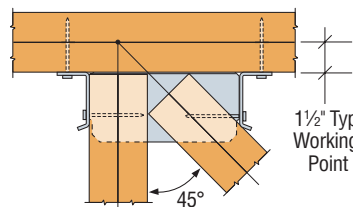

THJU26-W Top View
2-Ply Hip/2-Ply Jack Installation

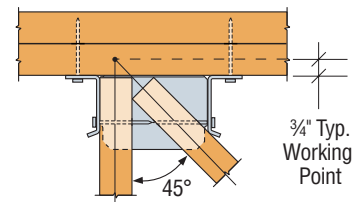

THJU26 Top View
Right Hand Hip Installation

Plated Truss Connectors

Model No.	Min. Carried Member	Dimensions (in.)			Fasteners			DF/SP Allowable Loads					SPF/HF Allowable Loads					Code Ref.
		W	H	B	Carrying Member	Hip	Jack	Uplift (160)	Download				Uplift (160)	Download				
									Floor (100)	Snow (115)	Roof (125)	Wind (160)		Floor (100)	Snow (115)	Roof (125)	Wind (160)	
THJU26	2x4	5½	5½	3½	16-10d	4-10d	4-10d	745	1915	1915	1915	1915	645	1645	1645	1645	1645	F23
	2x6 or End. Vert. ³				16-10d	7-10d	7-10d	1310	2255	2350	2350	2350	1125	1935	2020	2020	2020	
THJU26-W	2x4	8½	5½	3½	16-10d	4-10d	4-10d	710	1825	1825	1825	1825	610	1570	1570	1570	1570	
	2x6 or End. Vert. ³				16-10d	7-10d	7-10d	1240	1965	1965	1965	1965	1065	1690	1690	1690	1690	

1. Tabulated loads are the total allowable loads of the hip and jack members combined; 65%-85% of the total load shall be distributed to the hip member, and the remaining percentage of total load shall be distributed to the jack. The combined hip and jack load may not exceed the published total load.
2. Uplift loads have been increased 60% for wind or earthquake loading with no further increase allowed.
3. For full load, the jack requires either a min. 2x6 bottom chord or a min. 2x4 end vertical; the hip requires either a min. 2x6 bottom chord or a min. 2x6 end vertical for hip skews up to 60°. For hip skews greater than 60° (THJU26-W only), a min. 2x6 bottom chord or min. 2x8 end vertical is required.
4. With single 2x carrying members use 10dx1½" nails and use 100% of the table value.
5. For single 2x jacks, 10dx1½" nails may be substituted for the specified 10d commons with no reduction in load.
6. Truss chord cross-grain tension may limit allowable loads.
7. **NAILS:** 10d = 0.148" dia. x 3" long. See pages 22-23 for other nail sizes and information.

TJC Jack Truss Connector

TJC is a versatile connector for jack trusses. Adjustable from 0 to 85 degree (shipped with 67.5 degree bend). Nail hole locations allow for easy installation. Minimum nailing option on TJC37 provides faster installation and lower installed cost.

MATERIAL: 16 gauge

FINISH: Galvanized

INSTALLATION: • Use all specified fasteners; see General Notes.

- TJC37 can be installed filling round holes only, or filling round and triangle holes for maximum values.
- To reduce the potential for splitting, install the TJC with a minimum 3/16" edge distance on the chord members.
- Position the jack truss on the inside of the bend line with the end of the jack truss flush with the bend line.
- Bend the TJC to the desired position (one bend cycle only).
- No bevel cut required.
- Attachment of TJC to the top chord requires the Designer to check connection geometry for placement on both carried and carrying chord members. See Top Chord Member Sizes table below for suggested chord sizes.
- Supported jack member is a single 2x.

CODES: See page 12 for Code Reference Key Chart.

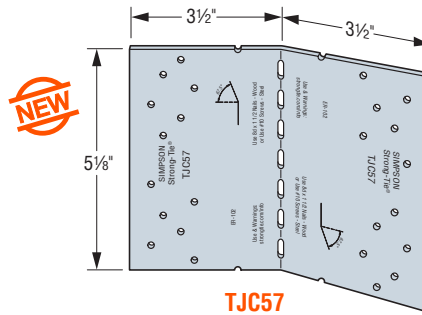

TJC57

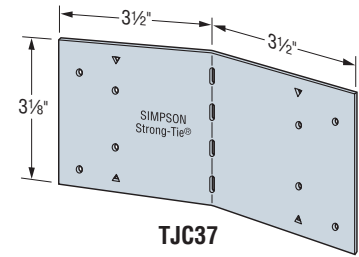

TJC37

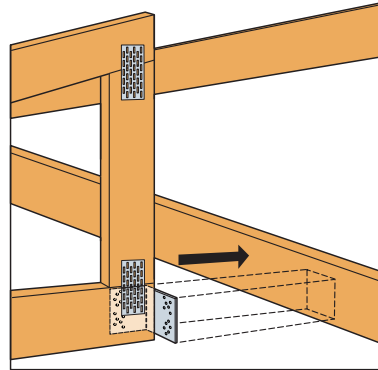

Typical TJC57 Standard Installation (TJC37 similar)

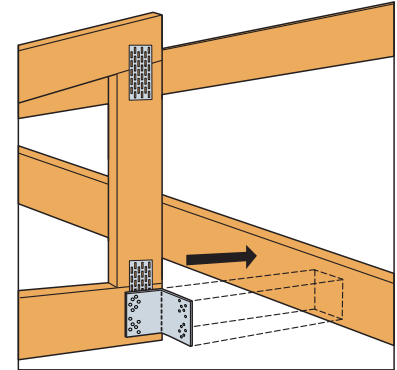

Typical TJC57 Alternate Installation (TJC37 similar)

Standard Installation

Model No.	Fasteners		Allowable Loads								Code Ref.
	Carrying Member	Carried Member	DF/SP				SPF/HF				
			0°	1°-60°	61°-67.5°	68°-85°	0°	1°-60°	61°-67.5°	68°-85°	
TJC37 (Min)	4-8dx1½	4-8dx1½	340	300	320	285	290	260	275	245	IP1, L18, F25
TJC37 (Max)	6-8dx1½	6-8dx1½	580	485	425	425	500	415	365	365	
TJC57	12-8dx1½	12-8dx1½	865	830	850	850	745	715	730	730	
	12-SD9112	12-SD9112	1140	990	990	990	980	850	850	850	

Alternate Installation

Model No.	Fasteners		Allowable Loads			
	Carrying Member	Carried Member	DF/SP		SPF/HF	
			0°	1°-45°	0°	1°-45°
TJC37 (Alt. Min)	4-8dx1½	4-8dx1½	255	225	220	195
TJC37 (Alt. Max)	6-8dx1½	6-8dx1½	435	365	375	310
TJC57 (Alt.)	12-8dx1½	12-8dx1½	785	740	675	635

1. No load duration increase allowed.
2. Allowable loads are for forward or downward direction.
3. TJC37 and TJC57 require single-ply carried members with minimum 2x4 and 2x6 cord members, respectively.
4. For back-to-back installation on a single-ply girder/hip member, use a 0.70 reduction of table loads.
5. **NAILS:** 8dx1½ = 0.131" dia. x 1½" long. See pages 22-23 for other nail sizes and information.
SCREWS: SD9112 = 0.131" dia. x 1½" long.

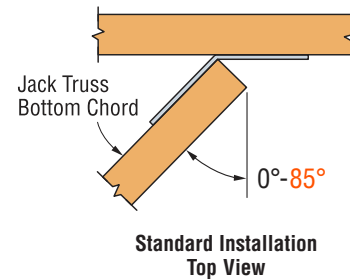

Standard Installation Top View

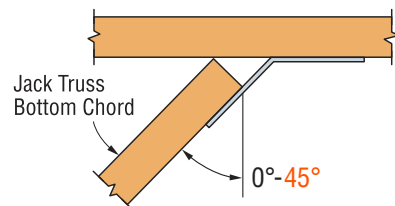

Alternate Installation Top View

Top Chord Member Sizes			
Part	Pitch		
	≤ 3:12	≤ 7:12	≤ 12:12
TJC37	2x6	2x6	2x8
TJC57	2x8	2x8	2x10

LTHJA26 Truss Hip/Jack Hangers



This product is preferable to similar connectors because of a) easier installation, b) higher loads, c) lower installed cost, or a combination of these features.

The LTHJA26 is a lighter capacity version of the THJA26 and offers the lowest cost alternative for light hip/jack load applications.

MATERIAL: 18 gauge

FINISH: Galvanized

INSTALLATION:

- Use all specified fasteners. See General Notes.
- Shall be attached to a double girder truss to allow for required minimum nail penetration. See footnote 3.
- 10dx1½" nails must be installed into bottom of hip members through bottom of hanger seat for table loads.

OPTIONS: These hangers can not be modified.

CODES: See page 12 for Code Reference Key Chart.

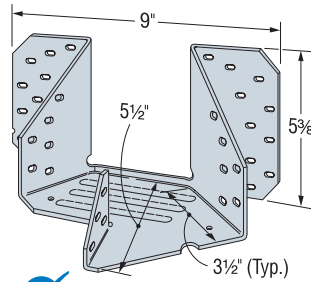

LTHJA26
US Patent 7,913,472

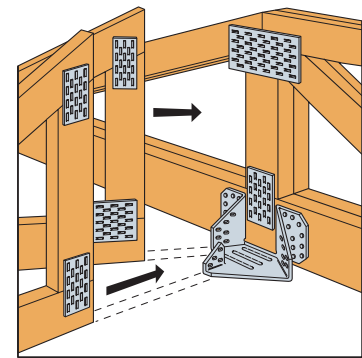

Typical LTHJA26 Installation

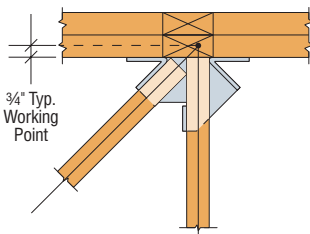

Top View
Left Hand Hip Installation

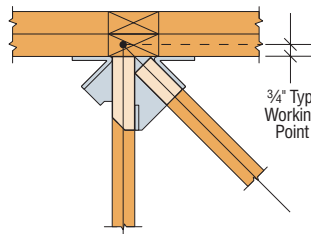

Top View
Right Hand Hip Installation

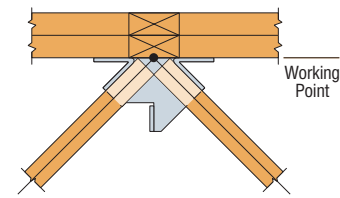

Top View
Terminal Hip without
Center Common Jack

Model No.	Carried Member Combination	Fasteners			Carried Member	DF/SP Allowable Loads					SPF/HF Allowable Loads					Code Ref.
		Carrying Member	Hip (each)	Jack		Uplift (160)	Floor (100)	Snow (115)	Roof (125)	Wind (160)	Uplift (160)	Floor (100)	Snow (115)	Roof (125)	Wind (160)	
LTHJA26	Side Hip & Center Jack	20-10d	7-10dx1½	4-10dx1½	Jack	75	290	290	290	290	65	245	245	245	245	I11, F10
					Hip	220	875	875	875	875	185	735	735	735	735	
					Hip & Jack	295	1165	1165	1165	1165	250	980	980	980	980	
	Double (Terminal) Hip	20-10d	7-10dx1½	—	Hip (each)	290	635	635	635	635	245	535	535	535	535	
Two Hips					580	1270	1270	1270	1270	490	1070	1065	1065	1065		

1. Uplift loads have been increased 60% for wind or earthquake loading with no further increase allowed; reduce where other loads govern.
2. Wind (160) is a download rating.
3. Loads shown are based on a minimum 2-2x6 carrying member. For single 2x carrying members (min. 2x6), use 10dx1½" nails and use 0.67 of the table value.
4. Tabulated hip and jack allowable loads assume that 75% of the total load is distributed to the hip and 25% to the jack. It is permitted to distribute 65% to 85% of the tabulated total load to the hip, and the remaining percentage of total load to the jack. The combined hip and jack load may not exceed the published Total Load.
5. Truss chord cross-grain tension may limit allowable loads in accordance with ANSI/TPI 1-2007. Simpson Strong-Tie® Connector Selector™ Software includes the evaluation of cross-grain tension in its hanger allowable loads. For additional information, contact Simpson Strong-Tie.
6. **NAILS:** 10d = 0.148" dia. x 3" long, 10dx1½ = 0.148" dia. x 1½" long. See pages 22-23 for other nail sizes and information.

THJA26 Truss Hip/Jack Hangers

The versatile THJA26 can accommodate right or left hand hips (at 45-degree skews), and can be installed before or after the hip and jack. Can also be used for double (terminal) hips.

MATERIAL: 14 gauge

FINISH: Galvanized

INSTALLATION: • Use all specified fasteners.
See General Notes.

- All multiple members must be fastened together to act as a single unit.
- Shall be attached to a double girder truss to allow for required minimum nail penetration. See footnote 3.

OPTIONS: These hangers cannot be modified.

CODES: See page 12 for Code Reference Key Chart.

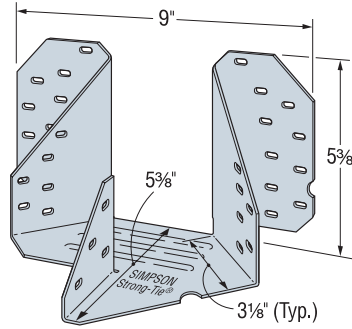

THJA26

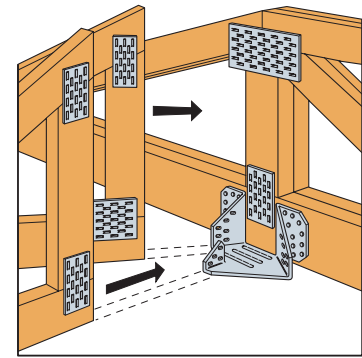

Typical THJA26 Installation

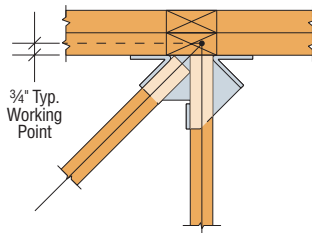

Top View
Left Hand Hip Installation

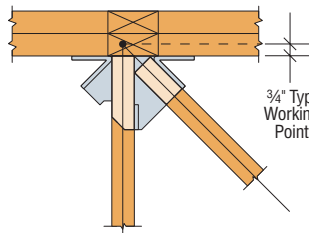

Top View
Right Hand Hip Installation

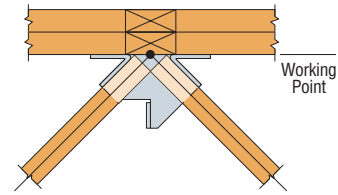

Top View
Terminal Hip without
Center Common Jack

Model No.	Fasteners			Carried Member	DF/SP Allowable Loads					SPF/HF Allowable Loads					Code Ref.
	Carrying Member	Hip	Jack		Uplift (160)	Floor (100)	Snow (115)	Roof (125)	Wind (160)	Uplift (160)	Floor (100)	Snow (115)	Roof (125)	Wind (160)	
THJA26	20-16d	6-10dx1½	4-10dx1½	Hip	720	2010	2310	2450	2450	590	1740	2000	2100	2100	I11, F10
				Jack	240	670	770	815	815	195	580	670	700	700	
				Total	960	2680	3080	3265	3265	785	2320	2670	2800	2800	

1. Uplift loads have been increased for wind or earthquake loading with no further increase allowed; reduce where other loads govern.
2. Wind (160) is a download rating.
3. Loads shown are based on a minimum 2-2x6 carrying member. For single 2x carrying members (min. 2x6), use 10dx1½" nails and use 0.67 of the table value. For 2-2x4 carrying members, multiply the download by 0.50.
4. 16d sinkers (0.148" dia. x 3¼" long) may be substituted for the specified 16d commons at 0.85 of the table load.
5. Tabulated hip and jack allowable loads assume that 75% of the total load is distributed to the hip and 25% to the jack. It is permitted to distribute 65% to 85% of the tabulated total load to the hip, and the remaining percentage of total load to the jack. The combined hip and jack load may not exceed the published Total Load.
6. For terminal hips, divide the total allowable load by 2 to determine the allowable load for each hip.
7. Truss chord cross-grain tension may limit allowable loads in accordance with ANSI/TPI 1-2007. Simpson Strong-Tie® Connector Selector™ Software includes the evaluation of cross-grain tension in its hanger allowable loads. For additional information, contact Simpson Strong-Tie.
8. **NAILS:** 16d = 0.162" dia. x 3½" long, 10dx1½ = 0.148" dia. x 1½" long. See pages 22-23 for other nail sizes and information.

MTHMQ/MTHMQ-2 Multiple Truss Hangers

The MTHMQ and MTHMQ-2 are redesigned versions of our medium-to-high load capacity hangers for carrying 2 or 3 trusses. The new design offers concealed flanges and installs with Simpson Strong-Tie® Strong-Drive® SDS Heavy-Duty Connector screws for easier installation.

MATERIAL: 12 gauge
FINISH: Galvanized (G90)

INSTALLATION:

- Use all specified fasteners. See General Notes.
- Can be installed filling round holes only, or filling round and triangle holes for maximum load. For all installations, fill the fastener holes in the bottom of the hanger seat.
- For installations at panel points with 2x6 bottom chords, do not fill the triangle holes unless approved by the Truss Designer.

CODES: See page 12 for Code Reference Key Chart.

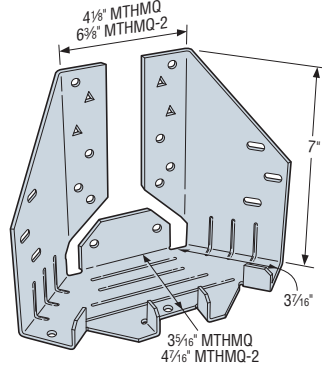

MTHMQ-SDS3
(MTHMQ-2-SDS3 similar)

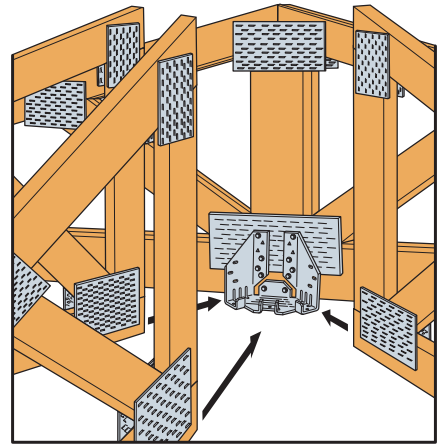

Typical MTHMQ Min. Installation at Panel Point

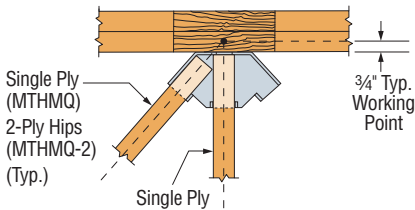

MTHMQ Top View Left Hand Hip Installation
(MTHMQ-2 similar)

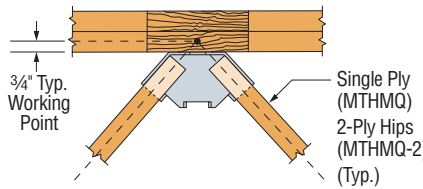

MTHMQ Top View Terminal Installation without Center Common Jack
(MTHMQ-2 similar)

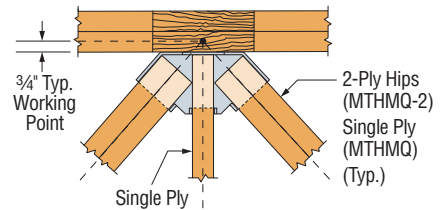

MTHMQ-2 Top View Terminal Installation with Center Common Jack
(MTHMQ similar)

Right or Left Hand Hip Installation (Two-Member Connection)^{3,4}

Model No.	Min. Carrying Member ^{2,3}	Fasteners			DF/SP Allowable Loads						SPF/HF Allowable Loads						Code Ref.
		Carrying Member	Hip	Jack	Uplift (160)			Download (100/115/125/160)			Uplift (160)			Download (100/115/125/160)			
					Hip	Jack	Total	Hip	Jack	Total	Hip	Jack	Total	Hip	Jack	Total	
MTHMQ-SDS3 (Min)	(2)-2x6	10-1/4"x3" SDS	4-1/4"x3" SDS	1-1/4"x3" SDS	440	145	585	1965	655	2620	315	105	420	1415	470	1885	170
MTHMQ-SDS3 (Max)	(2)-2x8	14-1/4"x3" SDS	4-1/4"x3" SDS	1-1/4"x3" SDS	440	145	585	2715	905	3620	315	105	420	1955	650	2605	
MTHMQ-2-SDS3 (Min)	(2)-2x6	12-1/4"x3" SDS	5-1/4"x3" SDS	1-1/4"x3" SDS	800	265	1065	2905	970	3875	575	190	765	2090	700	2790	
MTHMQ-2-SDS3 (Max)	(2)-2x8	16-1/4"x3" SDS	5-1/4"x3" SDS	1-1/4"x3" SDS	800	265	1065	3330	1110	4440	575	190	765	2395	800	3195	

Terminal Type Installation (Three-Member Connection)⁵

Model No.	Min. Carrying Member ^{2,3}	Fasteners			DF/SP Allowable Loads						SPF/HF Allowable Loads						Code Ref.
		Carrying Member	Hips (Total)	Jack	Uplift (160)			Download (100/115/125/160)			Uplift (160)			Download (100/115/125/160)			
					Hip (Ea)	Jack	Total	Hip (Ea)	Jack	Total	Hip (Ea)	Jack	Total	Hip (Ea)	Jack	Total	
MTHMQ-SDS3 (Min)	(2)-2x6	10-1/4"x3" SDS	8-1/4"x3" SDS	1-1/4"x3" SDS	505	250	1260	1470	730	3670	360	185	905	1055	530	2640	170
MTHMQ-SDS3 (Max)	(2)-2x8	14-1/4"x3" SDS	8-1/4"x3" SDS	1-1/4"x3" SDS	505	250	1260	1985	995	4965	360	185	905	1430	715	3575	
MTHMQ-2-SDS3 (Min)	(2)-2x6	12-1/4"x3" SDS	10-1/4"x3" SDS	1-1/4"x3" SDS	685	340	1710	2015	1010	5040 ⁷	490	250	1230	1450	730	3630 ⁷	
MTHMQ-2-SDS3 (Max)	(2)-2x8	16-1/4"x3" SDS	10-1/4"x3" SDS	1-1/4"x3" SDS	685	340	1710	2655	1330	6640	490	250	1230	1910	960	4780	

1. Allowable loads have been increased for wind or earthquake loading with no further increase allowed; reduce where other loads govern.
2. A minimum 2-ply carrying member is required for the tabulated loads. With single 2x carrying members, use 1/4"x1 1/2" Strong-Drive® SDS Heavy-Duty Connector screws into the carrying member and reduce the load to 0.60 of the table value.
3. For installations on 2x6 carrying members not at a panel point, the four uppermost face fasteners are not installed. For installations on 2x6 carrying members at a panel point, fasteners are installed into the round holes only (minimum vertical member sizes are 2x6 and 2x8 for the MTHMQ and MTHMQ-2, respectively).
4. Tabulated two-member allowable loads assume that 75% of the total load is distributed to the hip and 25% to the jack. It is permitted to distribute 65% to 85% of the tabulated total load to the hip, and the remaining percentage of total load to the jack. The combined hip and jack load may not exceed the published Total Load.

5. For terminal hips divide the total allowable load by 2 to determine the allowable load for each hip.
6. Tabulated three-member loads assume that each hip carries 40% of the total load and the jack carries 20% of the total load. Other hip/jack load distributions are allowed if the sum of all three carried members does not exceed the total load and the hip members are equally loaded.
7. The total allowable download for the MTHMQ-2-SDS3 (Min) for a 3-member connection at the 115/125/160 load duration is 5400 lbs. (DF/SP) and 3890 lbs. (SPF/HF).
8. Truss chord cross-grain tension may limit allowable loads as determined by the Designer in accordance with ANSI/TPI 1-2007.
9. Simpson Strong-Tie Strong-Drive SDS Heavy-Duty Connector screws are permitted to be installed through metal truss plates as approved by the Truss Designer, provided the requirements of ANSI/TPI 1-2007 Section 7.5.3.4 and 8.9.2 are met (pre-drilling required through the plate using a maximum of 5/32" bit).

THJM Multiple Truss Hip Jack Hanger

The THJM is a non-welded hanger designed to carry radial-end jack framing and provide optimal efficiency for those multi-plane, angled bay roofs over breakfast, study and library alcoves. The unique patent pending design of the THJM accommodates 2x4 girder bottom chords and uses our Strong-Drive® SDS Heavy-Duty Connector screws for easy installation with minimal fasteners.

FEATURES:

- The THJM hangers are designed for installation with ¼"x3" Strong-Drive® SDS Heavy-Duty Connector screws that are included with the parts.
- The THJM2-4-SDS3 is designed for four incoming jack trusses with the outer jacks being 22½° from the face of the girder and the inner jacks being 45° from each other and the outer jacks.
- The THJM2-5-SDS3 is designed for five jacks coming into the hanger at 30° from the girder and each other.
- Tabs on the seats of the THJM assist in the placement of the jacks and also include obround holes for optional slant nails (10dx1½") when increased uplift is required.

MATERIAL: 12 gauge **FINISH:** Galvanized

INSTALLATION: • Use all specified fasteners. See General Notes.

- Each carried jack truss requires one ¼"x3" Strong-Drive SDS Heavy-Duty Connector screw installed into the bottom chord through the bottom of the hanger seat.
- For installation on girders with 2x6 or 2x8 bottom chords, install one additional ¼"x3" Strong-Drive SDS Heavy-Duty Connector screw in the triangular hole on each vertical strap.
- Install two (2) 10dx1½" slant nails in the obround holes on each of the seat tabs to achieve the additional uplift load noted in the footnote.

CODES: See page 12 for Code Reference Key Chart.

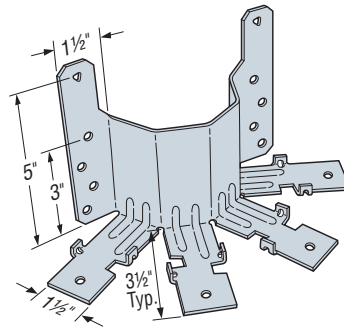

THJM2-4-SDS3
(THJM2-5-SDS3 similar)
U.S. Patent Pending

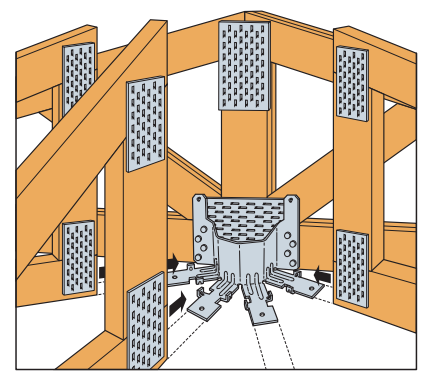

Typical THJM Installation

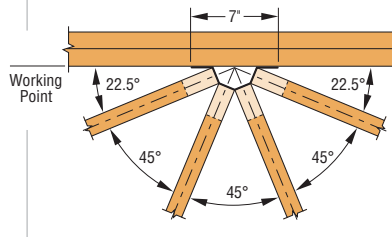

THJM2-4-SDS3
Top View Installation

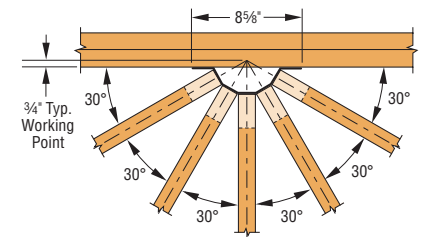

THJM2-5-SDS3
Top View Installation

Model No.	Fasteners		DF/SP Allowable Loads				SPF/HF Allowable Loads				Code Ref.		
	Carrying Member ³	Carried Members (Total)	Total Uplift (160) ⁶	Total Download				Total Uplift (160) ⁶	Total Download				
				Floor (100)	Snow (115)	Roof (125)	Wind (160)		Floor (100)	Snow (115)		Roof (125)	Wind (160)
THJM2-4-SDS3	8-¼"x1½" SDS	4-¼"x3" SDS	535	2000	2300	2500	3030	535	1440	1655	1800	2180	I13, F12
	8-¼"x3" SDS	4-¼"x3" SDS	535	3270	3270	3270	3270	535	2355	2355	2355	2355	
THJM2-5-SDS3	8-¼"x1½" SDS	5-¼"x3" SDS	620	2000	2300	2500	3030	445	1440	1665	1800	2180	
	8-¼"x3" SDS	5-¼"x3" SDS	620	3360	3765	3765	3765	620	2420	2710	2710	2710	

1. Tabulated loads are the total allowable loads of all carried members combined; the load on any single carried member shall not exceed 25% of the total published load for the THJM2-4 or 20% of the total published load for the THJM2-5.
2. Uplift loads have been increased for wind or earthquake loading with no further increase allowed. Reduce where other loads govern.
3. A minimum 2-ply carrying member is required for the ¼"x3" Strong-Drive® SDS Heavy-Duty Connector screws (provided). For single 2x carrying members, use ¼"x1½" Strong-Drive SDS screws (not supplied) with corresponding loads.
4. A minimum 2-ply carrying member is required for the tabulated loads.
5. Truss chord cross-grain tension may limit allowable loads per ANSI/TPI 1-2007. The optional triangle holes may be used for installation on 2x6 and larger carrying members, for a total of 10 fasteners into the carrying member, to resist cross-grain tension forces when no other mechanical reinforcement is available.
6. Tabs on the seats of the THJM hangers have obround holes for optional 10dx1½" slant nails (2 per carried member) when additional uplift capacity is required. Total allowable uplift with the optional 10dx1½" slant nailing is 970 lbs. (DF/SP/SPF/HF).

DSC Drag Strut Connector

The DSC drag-strut connector transfers the diaphragm shear forces from the girder truss or beam to the shearwalls. The new DSC5 has been designed to optimize fastener location, resulting in a connector that outperforms the DSC4 with fewer fasteners. The DSC2 is a smaller, lighter version that installs with fewer screws.

FEATURES

- The DSC5 requires 40% fewer fasteners than our previous DSC4, and gets 12% higher loads
- Left hand and right hand versions available
- DSCs install with the ¼"x3" Simpson Strong-Tie® Strong-Drive® SDS Heavy-Duty Connector screws provided

MATERIAL: DSC2—7 gauge, DSC5—3 gauge

FINISH: DSC2—Galvanized; DSC5—Simpson Strong-Tie® gray paint

INSTALLATION: • Use all specified fasteners; see General Notes.
• Strong-Drive SDS Heavy-Duty Connector screws are provided.

CODES: See page 12 for Code Reference Key Chart.

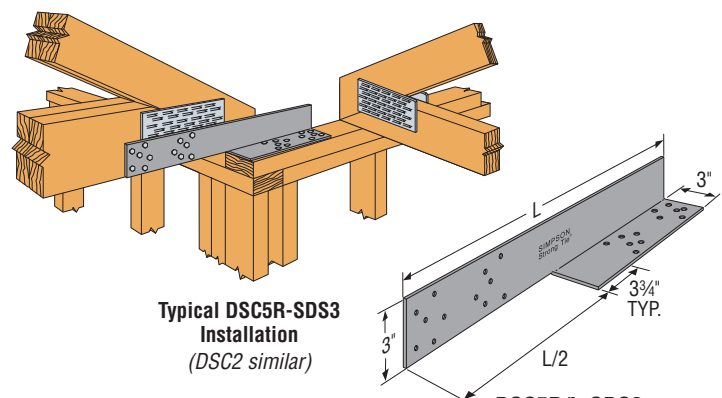

Typical DSC5R-SDS3
Installation
(DSC2 similar)

DSC5R/L-SDS3

(DSC2 similar)
(Right hand DSC shown; specify right or left hand when ordering)
U.S. Patent 6,655,096

Model No.	L (in.)	Fasteners	DF/SP Allowable Loads		SPF/HF Allowable Loads		Code Ref.
			Compression (160)	Tension (160)	Compression (160)	Tension (160)	
DSC2R/L-SDS3	16	20-¼"x3" SDS	2590	3720	1865	2680	F12
DSC5R/L-SDS3	21	24-¼"x3" SDS	4745	5925	3415	4265	

1. Allowable loads have been increased 60% for wind or earthquake loading with no further increase allowed; reduce where other loads govern.
2. Simpson Strong-Tie® Strong-Drive® SDS Heavy-Duty Connector screws minimum penetration is 2¾", minimum end distance is 2½" for DSC2 and 3¾" for DSC5 and minimum edge distance is ¾" for full load values.
3. Simpson Strong-Tie Strong-Drive SDS Heavy-Duty Connector screws are permitted to be installed through metal truss plates as approved by the Truss Designer, provided the requirements of ANSI/TPI 1-2007 Section 7.5.3.4 are met (pre-drilling required through the plate using a maximum of ½" bit).

THGQ/THGQH/HTHGQ SCL-to-Truss Girder Hangers



This product is preferable to similar connectors because of a) easier installation, b) higher loads, c) lower installed cost, or a combination of these features.

A lower cost alternative to bolted hangers, the THGQ and THGQH hangers for multi-ply girder trusses use Simpson Strong-Tie® Strong-Drive® SDS Heavy-Duty Connector screws to provide high load capacities and easier installation compared to bolts. The Strong-Drive® SDS Heavy-Duty Connector screws help transfer the load between the plies of the supporting girder when they penetrate all plies.

THGQ and THGQH models offer minimum and optional maximum fastener quantities to accommodate varying design needs. Allowable loads for various girder web member sizes provide additional installation options.

The HTHGQ is a high-load version designed to carry multi-ply trusses or composite lumber up to 5-ply girder trusses. For high-load capacities and easier installation compared to bolts, the HTHGQ is designed for use with Simpson Strong-Tie Strong-Drive SDS Heavy-Duty Connector screws.

MATERIAL: THGQ—7 gauge, THGQH/HTHGQ—3 gauge
FINISH: THGQ—Galvanized, THGQH/HTHGQ—Simpson Strong-Tie® gray paint

- INSTALLATION:**
- Use all specified fasteners. See General Notes.
 - Can be installed filling round holes only, or filling round and triangle holes for maximum values.
 - Strong-Drive SDS Heavy-Duty Connector screws supplied for all round and triangle holes. Installation may not require use of all Strong-Drive SDS Heavy-Duty Connector screws.
 - All multiple members must be fastened together to act as a single unit.
 - The thickness of the supporting girder must be equal to or greater than the screw length. For applications where the length of the supplied screws exceeds the thickness of the supporting girder, 3" or 4½" screws may be substituted for the longer length screws with no load reduction, or a shim block may be used as approved by the Designer.
 - Girders must be adequately laterally braced to prevent excessive displacement due to secondary torsional stresses (Ref ANSI/TPI 1-2007 Section 7.5.3.5).

OPTIONS: THGQH hangers for multi-ply truss girders may be skewed 45 degrees. THGQH for structural composite lumber (SCL) cannot be skewed. See Hanger Options on pages 233-243.

CODES: See page 12 for Code Reference Key Chart.

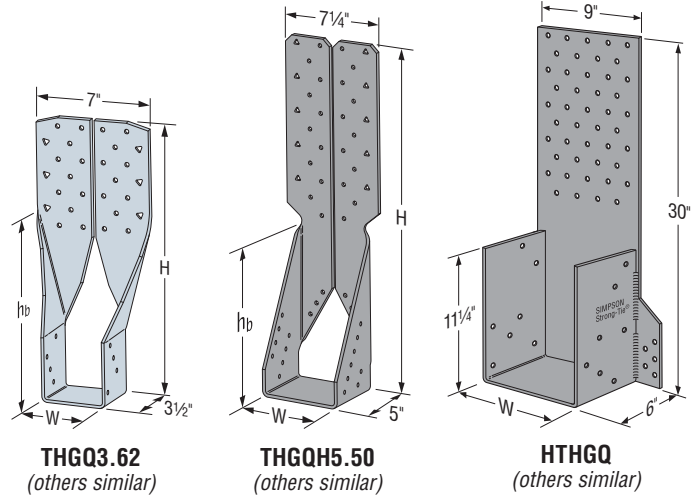

U.S. Patent Pending

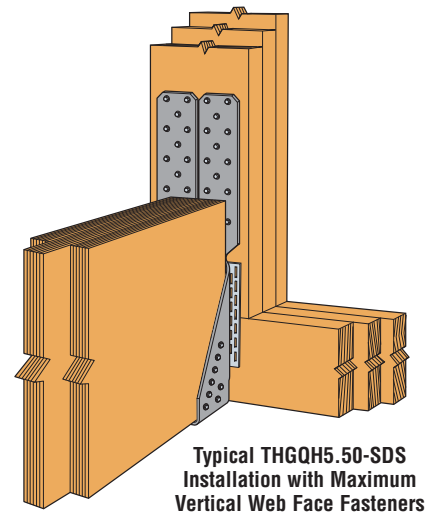
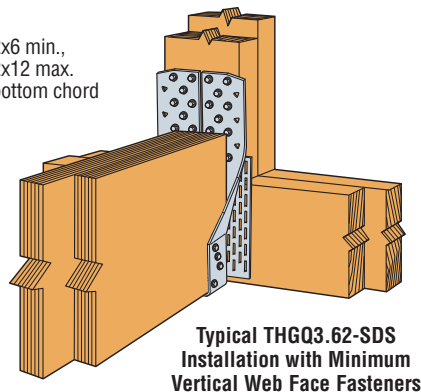
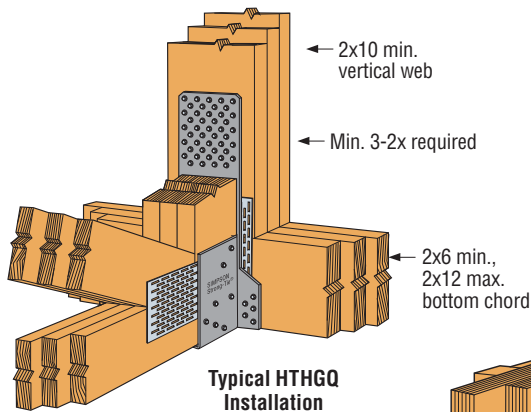
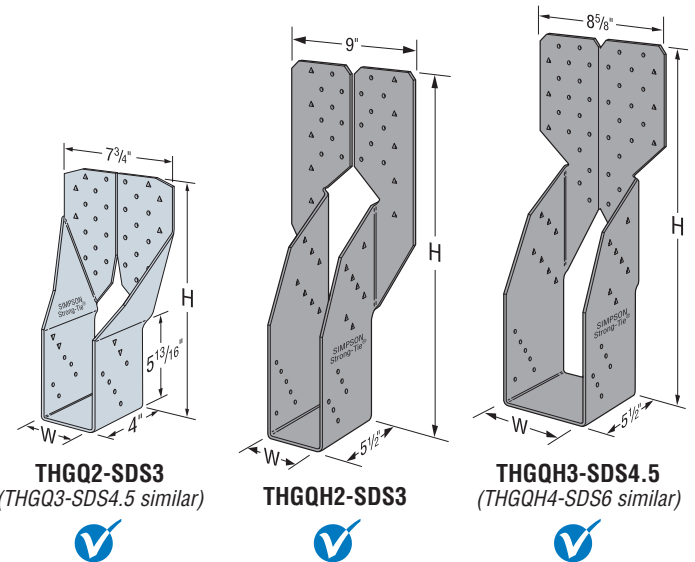

THGQ/THGQH/HTHGQ SCL-to-Truss Girder Hangers

Allowable Loads for Multi-Ply Truss Girder

Model No.	Dim. (in.)		Max. B.C. Depth	Min. Vert. Web Size	SDS Fasteners		DF/SP Allowable Loads					SPF/HF Allowable Loads					Code Ref.
	W	H			Face	Joist	Uplift (160)	Floor (100)	Snow (115)	Roof (125)	Wind (160)	Uplift (160)	Floor (100)	Snow (115)	Roof (125)	Wind (160)	
THGQ2-SDS3 (Min)	3 ⁹ / ₁₆	16	2x8	2x6	(22) 1/4"x3"	(10) 1/4"x3"	3600	7920	7920	7920	7920	2590	5700	5700	5700	F23	
					2x8		(28) 1/4"x3"	3600	10080	10080	10080	10080	2590	7260	7260		7260
THGQ2-SDS3 (Max)	3 ⁹ / ₁₆	16	2x8	2x6	(22) 1/4"x3"	(14) 1/4"x3"	4535	9240	9770	9770	9770	3265	6655	7035	7035		
				2x8	(28) 1/4"x3"		4535	11760	12435	12435	12435	3265	8465	8955	8955		
THGQH2-SDS3 (Min)	3 ⁹ / ₁₆	25	2x10	2x6	(18) 1/4"x3"	(12) 1/4"x3"	3875	7560	8275	8275	8275	2790	5445	5960	5960		
				2x8	(28) 1/4"x3"		3875	11760	11950	11950	11950	2790	8465	8605	8605		
THGQH2-SDS3 (Max)	3 ⁹ / ₁₆	25	2x10	2x6	(18) 1/4"x3"	(26) 1/4"x3"	7635	7560	7940	7940	7940	5495	5445	5715	5715		
				2x8	(28) 1/4"x3"		9900	11760	12350	12350	12350	7130	8465	8890	8890		
THGQ3-SDS4.5 (Min)	4 ¹⁵ / ₁₆	16	2x8	2x6	(22) 1/4"x4 1/2"	(10) 1/4"x4 1/2"	3600	7920	7920	7920	7920	2590	5700	5700	5700		
				2x8	(28) 1/4"x4 1/2"		3600	10080	10080	10080	10080	2590	7260	7260	7260		
THGQ3-SDS4.5 (Max)	4 ¹⁵ / ₁₆	16	2x8	2x6	(22) 1/4"x4 1/2"	(14) 1/4"x4 1/2"	4535	9140	9140	9140	9140	3265	6580	6580	6580		
				2x8	(28) 1/4"x4 1/2"		4535	11635	11635	11635	11635	3265	8375	8375	8375		
THGQH3-SDS4.5 (Min)	4 ¹⁵ / ₁₆	25	2x10	2x8	(32) 1/4"x4 1/2"	(12) 1/4"x4 1/2"	3875	12565	12565	12565	12565	2790	9045	9045	9045		
				2x10	(38) 1/4"x4 1/2"		3875	14920	14920	14920	14920	2790	10740	10740	10740		
THGQH3-SDS4.5 (Max)	4 ¹⁵ / ₁₆	25	2x10	2x8	(32) 1/4"x4 1/2"	(26) 1/4"x4 1/2"	9900	12980	12980	12980	12980	7130	9345	9345	9345		
				2x10	(38) 1/4"x4 1/2"		9900	15415	15415	15415	15415	7130	11100	11100	11100		
THGQH4-SDS6 (Min)	6 ⁹ / ₁₆	25	2x12	2x8	(34) 1/4"x6"	(12) 1/4"x6"	3875	13875	13875	13875	13875	2790	9990	9990	9990		
				2x10	(40) 1/4"x6"		3875	16320	16320	16320	16320	2790	11750	11750	11750		
THGQH4-SDS6 (Max)	6 ⁹ / ₁₆	25	2x12	2x8	(34) 1/4"x6"	(26) 1/4"x6"	9900	14280	14335	14335	14335	7130	10280	10320	10320		
				2x10	(40) 1/4"x6"		9900	16800	16865	16865	16865	7130	12095	12145	12145		

1. Allowable uplift loads have been increased for wind or earthquake loading with no further increase allowed; reduce where other loads govern.
2. Connector must be installed centered on girder vertical webs.
3. Simpson Strong-Tie® Strong-Drive® SDS Heavy-Duty Connector screws are permitted to be installed through metal truss plates as approved by the Truss Designer, provided the requirements of ANSI/TPI 1-2007 Section 7.5.3.4 and 8.9.2 are met (*pre-drilling required through the plate using a maximum of 3/32" bit*).
4. Strong-Drive SDS Heavy-Duty Connector screws that penetrate all plies of the supporting girder (*screws must penetrate a minimum of 1" into the last truss ply*) may also be used to transfer the load through all the plies of

- the supporting girder. When Strong-Drive SDS Heavy-Duty Connector screws do not penetrate all plies of the supporting girder truss, supplemental Strong-Drive SDS Heavy-Duty Connector screws at the hanger locations may be required to transfer the load to the truss plies not penetrated by the face fasteners, as determined by the Designer.
5. The supporting girder truss must have adequate thickness to accommodate the screw length, so that the screw does not protrude out the back of the girder. 3" or 4 1/2" long Strong-Drive SDS Heavy-Duty Connector screws may be substituted for the longer Strong-Drive SDS screws with no load reduction.
6. For installations to LSL, use 1/4"x3" Strong-Drive SDS Heavy-Duty Connector screws and use the DF/SP table loads.
7. Wind (160) is a download rating.

Model No.	Width (W)	SDS Fasteners		DF/SP Allowable Loads					SPF/HF Allowable Loads					Code Ref.
		Carrying Member	Carried Member	Uplift (160)	Floor (100)	Snow (115)	Roof (125)	Wind (160)	Uplift (160)	Floor (100)	Snow (115)	Roof (125)	Wind (160)	
HTHGQ2-SDS	3 ⁹ / ₁₆	(55) 1/4"x 4 1/2"	(14) 1/4"x 3"	3940	17130	18010	18600	20660	3390	11885	12520	12940	14425	170
HTHGQ3-SDS	4 ¹⁵ / ₁₆			3940	20735	20735	20735	20735	3390	15710	16345	16765	17835	
HTHGQ4-SDS	6 ⁹ / ₁₆			3940	20735	20735	20735	20735	3390	16630	17835	17835	17835	
HTHGQ5-SDS	8 ¹ / ₂			3940	20735	20735	20735	20735	3390	16630	17835	17835	17835	

1. Tabulated allowable loads must be selected based on duration of load as permitted by the applicable building code.
2. The uplift loads have been increased for wind or earthquake loading with no further increase allowed. Reduce when other load durations govern.
3. Wind (160) is a download rating.
4. Connector must be installed centered on minimum 2x10 vertical web.
5. A minimum 3-ply carrying member is required for the tabulated loads.

6. Carrying truss plies must be adequately fastened together as determined by Designer.
7. Truss chord cross-grain tension may limit allowable loads as determined by the Designer in accordance with ANSI/TPI 1-2007.
8. Simpson Strong-Tie® Strong-Drive® SDS Heavy-Duty Connector screws are permitted to be installed through metal truss plates as approved by the Truss Designer, provided the requirements of ANSI/TPI 1-2007 Section 7.5.3.4 and 8.9.2 are met (*pre-drilling required through the plate using a maximum of 3/32" bit*).

Allowable Loads for Structural Composite Lumber (SCL)

Model No.	Dimensions (in.)			Bottom Chord Size	Min. Vert. Web Size	SDS Fasteners		DF/SP Allowable Loads					SPF/HF Allowable Loads					Code Ref.
	W	H	h _b			Face	Joist	Uplift (160)	Floor (100)	Snow (115)	Roof (125)	Wind (160)	Uplift (160)	Floor (100)	Snow (115)	Roof (125)	Wind (160)	
THGQ3.62-SDS (Min)	3%	16 1/16	10	2x8 Max	2x6	(22) 1/4" x 3"	(8) 1/4" x 3"	2620	6310	6310	6310	6310	2250	5425	5425	5425	5425	
THGQ3.62-SDS (Max)					2x8	(28) 1/4" x 3"	(8) 1/4" x 3"	2620	8825	8825	8825	8825	2250	7360	7590	7590	7590	
THGQH3.62-SDS (Min)	3%	24 1/2	11	2x8 or 2x10	2x6	(26) 1/4" x 3"	(18) 1/4" x 3"	3525	10920	11080	11080	11080	3030	7800	8970	9530	9530	
THGQH3.62-SDS (Max)					2x8	(36) 1/4" x 3"	(18) 1/4" x 3"	3525	12080	12080	12080	12080	3030	10390	10390	10390	10390	
THGQ5.50-SDS (Min)	5 1/2	17 1/4	8 1/4	2x8 Max	2x6	(24) 1/4" x 4 1/2"	(8) 1/4" x 4 1/2"	2620	7315	7315	7315	7315	2250	6295	6295	6295	6295	
THGQ5.50-SDS (Max)					2x8	(32) 1/4" x 4 1/2"	(8) 1/4" x 4 1/2"	2620	8655	8655	8655	8655	2250	7445	7445	7445	7445	
THGQH5.50-SDS (Min)	5 1/2	25	11 1/4	2x8 or 2x10	2x6	(28) 1/4" x 4 1/2"	(16) 1/4" x 4 1/2"	3525	10640	10640	10640	10640	3030	8400	9150	9150	9150	
THGQH5.50-SDS (Max)					2x8	(38) 1/4" x 4 1/2"	(16) 1/4" x 4 1/2"	3525	15960	17325	17325	17325	3030	11400	13110	14250	14900	
THGQH7.25-SDS (Min)	7 1/4	24 1/2	11 1/4	2x8 or 2x10	2x6	(28) 1/4" x 6"	(16) 1/4" x 6"	3525	11760	12070	12070	12070	3030	8400	9660	10380	10380	
THGQH7.25-SDS (Max)					2x8	(38) 1/4" x 6"	(16) 1/4" x 6"	3525	15565	15565	15565	15565	3030	11400	13110	13385	13385	
					2x10	(46) 1/4" x 6"	(16) 1/4" x 6"	3525	18360	18360	18360	18360	3030	13800	15790	15790	15790	

See THGQ footnotes above.

THGBV/THGBHV/THGWV SCL-to-Truss Girder Hangers

An extension of the THGB/THGBH/THGW series, these high-capacity hangers are designed for attaching 2-ply, 3-ply or 4-ply sized structural composite lumber (SCL) to a girder truss. The THGBV offers optional installation with Simpson Strong-Tie® Strong-Drive® SDS Heavy-Duty Connector screws, while the bolted THGBHV and THGWV offer higher load capacities. Two bucket heights are available for each width to accommodate a range of SCL sizes. Options for skewing or dropping the buckets for conditions where the SCL joist is lower than the girder bottom chord provide additional design flexibility for a variety of SCL-to-truss connections.

MATERIAL: 3 gauge

FINISH: Simpson Strong-Tie® gray paint

INSTALLATION: • Use all specified fasteners. See General Notes.

- All multiple members must be fastened together to act as a single unit.
- Maximum 11 7/8" bottom chord in the carrying member to allow for the minimum bolt end distance.
- Bolts must be installed symmetrically when using less than 8 bolts on the 8-bolt backplate.
- Girders must be adequately laterally braced to prevent excessive displacement due to secondary torsional stresses (Ref. ANSI/TPI 1-2007 Section 7.5.3.5).
- Shall be attached to a 2-ply girder truss to allow for required minimum screw penetration. See footnote 4.

OPTIONS: • THGB/THGBH/THGBV/THGBHV hangers can be skewed to a maximum of 45°. Allowable download or uplift is 0.87 of table load. See Hanger Options pages 233-243 for additional options.

CODES: See page 12 for Code Reference Key Chart.

Joist Dimensions		Model No.	Hanger Dimensions		
Width	Depth		W	h _b	
3 1/2	9 1/4 - 14	THGBV3.62/9	3 3/4	9	
		THGBHV3.62/9		11	
	11 1/4 - 20	THGBV3.62/11			5 1/2
		THGBHV3.62/11			
5 1/4	9 1/4 - 14	THGBV5.50/9	7 1/4	9	
		THGBHV5.50/9		11	
		THGWV5.50/9			
	11 1/4 - 20	THGBV5.50/11			7 1/4
		THGBHV5.50/11			
		THGWV5.50/11			
7	9 1/4 - 14	THGBHV7.25/9	7 1/4	9	
		THGWV7.25/9		11	
	11 1/4 - 20	THGBHV7.25/11			
		THGWV7.25/11			

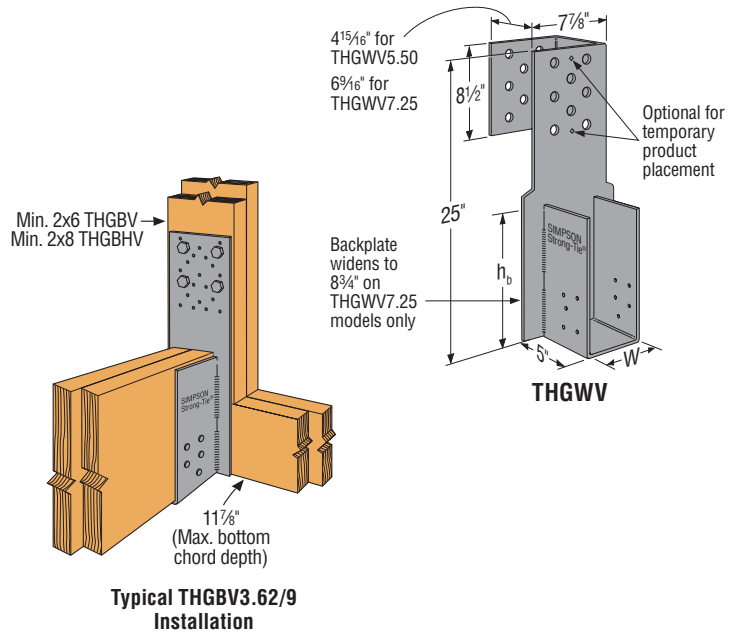
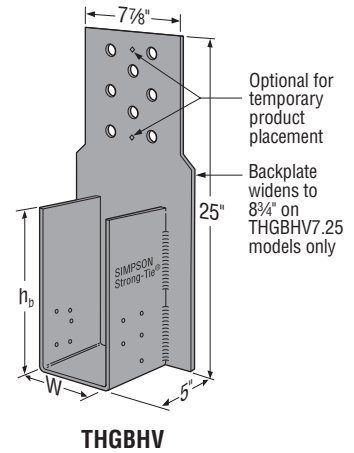
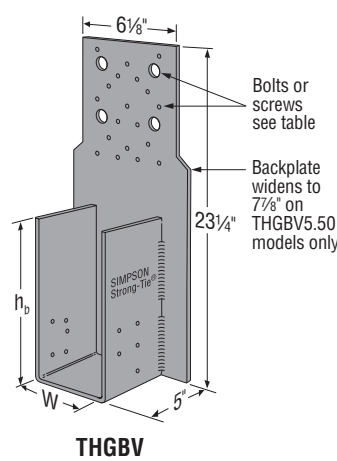

Plated Truss Connectors

QUIK DRIVE® AUTO-FEED SYSTEM FOR 2-PLY AND 3-PLY GIRDERS

Simpson Strong-Tie® Strong-Drive® WSNTL Wood screws are a safe, fast and reliable method for attaching multi-ply trusses. The WSNTL screws, like their Strong-Drive® SDW Truss-Ply and EWP-Ply screws counterpart, virtually eliminate ply separation during handling.



See the *Fastening Systems* catalog (form C-F-14) for more information.



Simpson Strong-Tie Strong-Drive WSNTL WOOD Screw

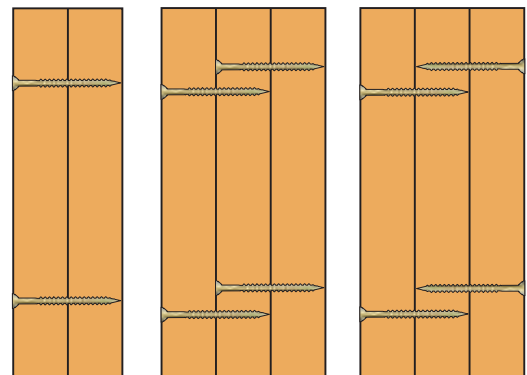

WSNTL Installation in 2-ply and 3-ply Assemblies

THGBV/THGBHV/THGWV SCL-to-Truss Girder Hangers

Model No.	Width (W)	Fasteners		Length of Bolt in Carrying Member	DF/SP Allowable Loads					SPF/HF Allowable Loads					Code Ref.
		Carried Member	Carrying Member		Uplift (160)	Floor (100)	Snow (115)	Roof (125)	Wind (160)	Uplift (160)	Floor (100)	Snow (115)	Roof (125)	Wind (160)	
THGBV3.62/9 THGBV3.62/11	3%	10-10d	4-3/4" MB	3	2570	6030	6835	7375	8715	2570	5160	5840	6290	7320	160
				4 1/2		6910	7780	8350	8715		6385	7185	7320	7320	
				6		6910	7780	8350	8715		6400	7200	7320	7320	
				19-SDS 1/4"x3"		7980	8675	8675	8675		5700	6245	6245	6245	
THGBHV3.62/9 THGBHV3.62/11	3%	10-10d	8-3/4" MB	3	2570	10105	10345	10505	10915	2570	7465	7675	7815	8285	160
				4 1/2		10915	10915	10915	10915		9165	9165	9165	9165	
				6		10915	10915	10915	10915		9165	9165	9165	9165	
THGBV5.50/9 THGBV5.50/11	5 1/4	10-10d	4-3/4" MB	3	2570	6030	6835	7375	8715	2570	5160	5840	6290	7320	160
				4 1/2		6910	7780	8350	8715		6385	7185	7320	7320	
				6		6910	7780	8350	8715		6400	7200	7320	7320	
				19-SDS 1/4"x3"		7980	8675	8675	8675		5700	6245	6245	6245	
THGBHV5.50/9 THGBHV5.50/11	5 1/4	10-10d	8-3/4" MB	3	2570	10915	10915	10915	10915	2570	9165	9165	9165	9165	160
				4 1/2		12665	12665	12665	12665		10500	10640	10640	10640	
				6		12815	12815	12815	12815		10500	10710	10765	10765	
THGBHV7.25/9 THGBHV7.25/11	7	10-10d	4-3/4" MB	3	2570	6040	6850	7390	8715	2570	5165	5845	6295	7320	160
				4 1/2		6910	7780	8350	8715		6385	7185	7320	7320	
				6		6910	7780	8350	8715		6400	7200	7320	7320	
THGBHV7.25/9 THGBHV7.25/11	7	10-10d	6-3/4" MB	3	2570	9065	10010	10010	10010	2570	7750	8410	8410	8410	160
				4 1/2		10010	10010	10010	10010		8410	8410	8410	8410	
				6		10010	10010	10010	10010		8410	8410	8410	8410	
THGBHV7.25/9 THGBHV7.25/11	7	10-10d	8-3/4" MB	3	2570	10915	10915	10915	10915	2570	9165	9165	9165	9165	160
				4 1/2		13830	15060	15060	15060		12650	12650	12650	12650	
				6		13830	15060	15060	15060		12650	12650	12650	12650	
THGWV5.50/9 THGWV5.50/11	5 1/4	10-10d	8-3/4" MB	4 1/2	2570	21320	21835	21835	21835	2570	18340	18340	18340	18340	160
THGWV7.25/9 THGWV7.25/11	7	10-10d	8-3/4" MB	6	2570	24165	24165	24165	24165	2570	20300	20300	20300	20300	160

- Allowable loads are based on a SCL (LVL, PSL or LSL) carried member with an allowable $F_c \perp$ of 750 psi and equivalent Specific Gravity of 0.50 or higher.
- Uplift loads have been increased for earthquake or wind loading with no further increase allowed. Reduce where other loads govern.
- A 3-ply carrying member is required for the THGWV5.50/9 and THGWV5.50/11; a 4-ply carrying member is required for the THGWV7.25/9 and THGWV7.25/11.
- Simpson Strong-Tie® Strong-Drive® SDS Heavy-Duty Connector screws require a minimum 2-ply (3") carrying member.
- Bolts and Simpson Strong-Tie Strong-Drive SDS Heavy-Duty Connector screws are permitted to be installed through metal truss connector plates as approved by the Truss Designer, provided the requirements of ANSI/TPI 1-2007 Sections 7.5.3.4 and 8.9.2 are met.
- Wind (160) is a download rating.
- To achieve published loads, machine bolts (MB) into the girder truss shall be installed with the nut on the opposite side of the hanger with a standard cut washer (except THGWVs). Standard cut washers are required for THGBV and THGBHV.
- NAILS:** 10d = 0.148" dia. x 3" long. See pages 22-23 for other nail sizes and information.

THGB/THGBH/THGW Truss Girder Hangers

High capacity, welded hangers for multi-ply girder trusses. The THGB series offers optional installation with Simpson Strong-Tie® Strong-Drive® SDS Heavy-Duty Connector screws, and the bolted THGBH and THGW hangers offer higher design loads. For a lower cost alternative that uses Strong-Drive SDS Heavy-Duty Connector screws instead of bolts and offers high load capacities, see the THGQ/THGQH series.

MATERIAL: 3 gauge

FINISH: Simpson Strong-Tie® gray paint

INSTALLATION: • Use all specified fasteners. See General Notes.

- All multiple members must be fastened together to act as a single unit.
- Maximum 11 7/8" bottom chord in the carrying member to allow for the minimum bolt end distance.
- Bolts must be installed symmetrically when using less than 8 bolts on the 8-bolt backplate.
- Girders must be adequately laterally braced to prevent excessive displacement due to secondary torsional stresses (Ref ANSI/TPI 1-2007 Section 7.5.3.5).

OPTIONS: • See Hanger Options, page 238 for THGB/THGBH skew options.

CODES: See page 12 for Code Reference Key Chart.

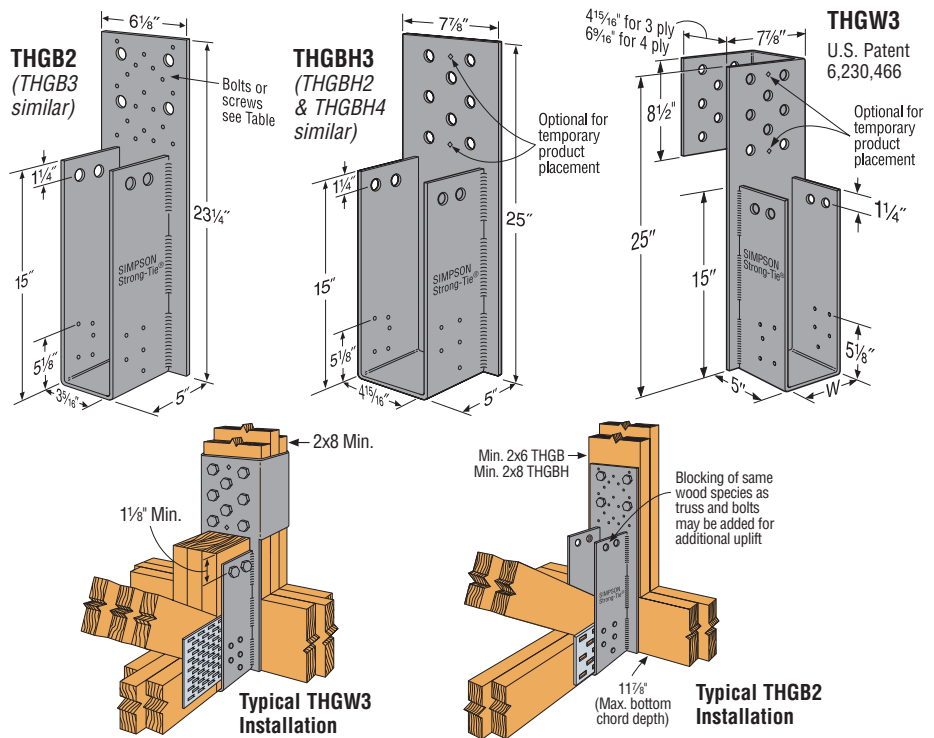

Plated Truss Connectors

Model No.	Width (W)	Fasteners		Length of Bolt in Carrying Member	DF/SP Allowable Loads					SPF/HF Allowable Loads					Code Ref.
		Carried Member	Carrying Member		Uplift ¹ (160)	Floor (100)	Snow (115)	Roof (125)	Wind (160)	Uplift ¹ (160)	Floor (100)	Snow (115)	Roof (125)	Wind (160)	
THGB2	3 5/8	10-10d & 2-3/4" MB	4-3/4" MB	3	9700	6030	6835	7375	8715	8145	5160	5840	6290	7320	F23
				4 1/2	9700	6910	7780	8350	8715	8145	6385	7185	7320	7320	
				6	9700	6910	7780	8350	8715	8145	6400	7200	7320	7320	
THGB2	3 5/8	10-10d & 2-3/4" MB	19-1/4"x3" SDS	—	8675	7980	8675	8675	8675	6245	5700	6245	6245	6245	
THGBH2	3 5/8	10-10d & 2-3/4" MB	8-3/4" MB	3	9700	10105	10345	10505	10915	8145	7465	7675	7815	8285	
				4 1/2	9700	10915	10915	10915	10915	8145	9165	9165	9165	9165	
				6	9700	10915	10915	10915	10915	8145	9165	9165	9165	9165	
THGB3	4 1/8	10-10d & 2-3/4" MB	4-3/4" MB	3	9700	6030	6835	7375	8715	8145	5160	5840	6290	7320	
				4 1/2	9700	6910	7780	8350	8715	8145	6385	7185	7320	7320	
				6	9700	6910	7780	8350	8715	8145	6400	7200	7320	7320	
THGB3	4 1/8	10-10d & 2-3/4" MB	19-1/4"x3" SDS	—	8675	7980	8675	8675	8675	6245	5700	6245	6245	6245	
THGBH3	4 1/8	10-10d & 2-3/4" MB	8-3/4" MB	3	9700	10915	10915	10915	10915	8145	9165	9165	9165	9165	
				4 1/2	9700	12665	12665	12665	12665	8145	10500	10640	10640	10640	
				6	9700	12815	12815	12815	12815	8145	10500	10710	10765	10765	
THGBH4	6 1/8	10-10d & 2-3/4" MB	4-3/4" MB	3	9700	6040	6850	7390	8715	8145	5165	5845	6295	7320	
				4 1/2	9700	6910	7780	8350	8715	8145	6385	7185	7320	7320	
				6	9700	6910	7780	8350	8715	8145	6400	7200	7320	7320	
THGBH4	6 1/8	10-10d & 2-3/4" MB	6-3/4" MB	3	9700	9065	10010	10010	10010	8145	7750	8410	8410	8410	
				4 1/2	9700	10010	10010	10010	10010	8145	8410	8410	8410	8410	
				6	9700	10010	10010	10010	10010	8145	8410	8410	8410	8410	
THGBH4	6 1/8	10-10d & 2-3/4" MB	8-3/4" MB	3	9700	10915	10915	10915	10915	8145	9165	9165	9165	9165	
				4 1/2	9700	13830	15060	15060	15060	8145	12650	12650	12650	12650	
				6	9700	13830	15060	15060	15060	8145	12650	12650	12650	12650	
THGW3-3 ⁶	4 1/8	10-10d & 2-3/4" MB	8-3/4" MB	4 1/2	9700	21830	21830	21830	21830	8145	18340	18340	18340	18340	
6				9700	21830	21830	21830	21830	8145	18340	18340	18340	18340		
THGW4-3 ⁶	6 1/8	10-10d & 2-3/4" MB	8-3/4" MB	4 1/2	9700	24165	24165	24165	24165	8145	20300	20300	20300	20300	
6				9700	24165	24165	24165	24165	8145	20300	20300	20300	20300		

1. Uplift loads have been increased for wind or earthquake loading with no further increase allowed; reduce where other loads govern.
2. A 3-ply carrying member is required for the THGW3-3 and THGW4-3; a 4-ply carrying member is required for the THGW3-4 and THGW4-4. For all other models, a minimum 2-ply carrying member is required.
3. Simpson Strong-Tie® Strong Drive® SDS Heavy-Duty Connector screws require a minimum 2-ply (3") carrying member.
4. Bolts and Simpson Strong-Tie Strong Drive screws are permitted to be installed through metal truss connector plates as approved by the Truss Designer, provided the requirements of ANSI/TPI 1-2007 Sections 7.5.3.4 and 8.9.2 are met.

5. 10-10d nails for the carried member will achieve the maximum down loads. Uplift loads are 2570 lbs. for DF/SP and 2210 lbs. for SPF/HF. To achieve maximum uplift, install nails and bolts listed in the table.
6. Loads for THGW models require that the supported member have minimum 2x6 end verticals to ensure end-grain bearing. Contact Simpson Strong-Tie for loads when horizontal members are bearing in the hanger seat.
7. Wind (160) is a download rating.
8. To achieve published loads, machine bolts (MB) into the girder truss shall be installed with the nut on the opposite side of the hanger with a standard cut washer (except THGWs). Standard cut washers are required for THGB and THGBH.
9. NAILS: 10d = 0.148" dia. x 3" long. See pages 22-23 for other nail sizes and information.

HTHMQ Heavy Multiple Truss Hangers

The HTHMQ is a versatile, high-capacity truss hanger designed for various lumber types and multiple-ply trusses. The truss hanger accommodates a greater range of structural designs while accommodating right or left hand hips (at 30°-60° skews), which can be used for terminal hips with or without the center common jack. The HTHMQ can accommodate various widths of lumber.

FEATURES:

- Available in various stirrup widths to accommodate various lumber types and multiple ply trusses
- Installed with Simpson Strong-Tie® Strong-Drive® SDS Heavy-Duty Connector screws that eliminate the inconvenience of bolted installation
- Enables 2-3 member connection for a broader range of structural designs

MATERIAL: Back plate—3 gauge; stirrup—7 gauge

FINISH: Simpson Strong-Tie® gray paint

INSTALLATION: • Use all specified fasteners.

See General Notes.

- Strong-Drive SDS Heavy-Duty Connector screws supplied with connector.
- All multiple members must be fastened together to act as a single unit.
- Shall be attached to a **minimum** double girder truss to allow for required minimum screw penetration. See footnote 5.
- Girders must be adequately laterally braced to prevent excessive displacement due to secondary torsional stresses (Ref ANSI/TPI 1-2007 Section 7.5.3.5).
- See below for different installation options.

CODES: See page 12 for Code Reference Key Chart.

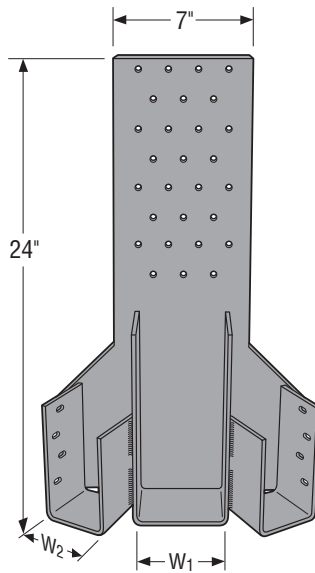

HTHMQ

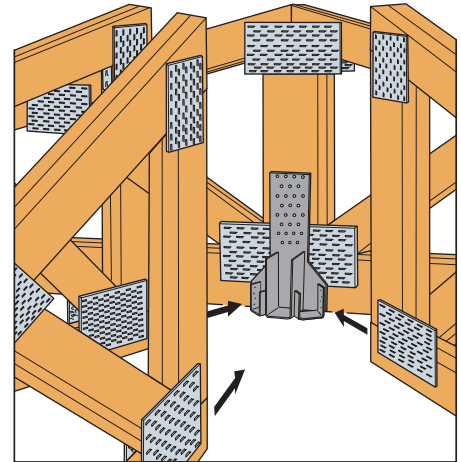

Typical HTHMQ Installation

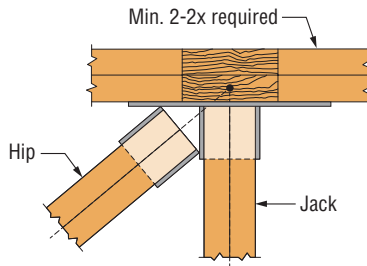

HTHMQL Top View
Left Hand Hip Installation

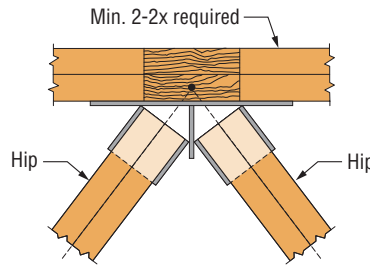

HTHMQN Top View
Terminal Hip Installation
without Common Center Jack

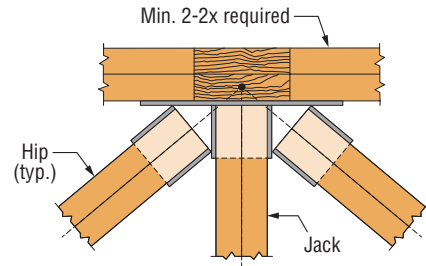

HTHMQ Top View
Terminal Installation
with Center Common Jack

Model No.	Dimensions (in.)			Fasteners			DF/SP Allowable Loads						SPF/HF Allowable Loads						Code Ref.
	W ₁	W ₂	Hip Skew Angle	Carrying Member	Hips (Total)	Jack	Uplift (160)			Down (100/115/125/160)			Uplift (160)			Down (100/115/125/160)			
							Hip (ea)	Jack	Total	Hip (ea)	Jack	Total	Hip (ea)	Jack	Total	Hip (ea)	Jack	Total	
HTHMQ-SDS	1½ - 4 1/16	1½	30°-60°	34-¼"x3" SDS	8-¼"x1½" SDS	4-¼"x1½" SDS	1085	545	2715	4045	2020	10110	935	470	2340	2790	1395	6975	170
HTHMQ-2-SDS	1½ - 4 1/16	3 3/16	30°-60°	34-¼"x3" SDS	8-¼"x2½" SDS	4-¼"x1½" SDS	1085	545	2715	4585	2290	11460	935	470	2340	3945	1970	9860	
HTHMQN-SDS	—	1½	30°-60°	34-¼"x3" SDS	8-¼"x1½" SDS	—	920	—	1840	4045	—	8090	790	—	1580	2790	—	5580	
HTHMQN-2-SDS	—	3 3/16	30°-60°	34-¼"x3" SDS	8-¼"x2½" SDS	—	920	—	1840	4695	—	9390	790	—	1580	4040	—	8080	
HTHMQR/L-SDS	1½ - 4 1/16	1½	30°-60°	34-¼"x3" SDS	4-¼"x1½" SDS	4-¼"x1½" SDS	1470	490	1960	4045	1350	5395	1265	420	1685	2790	930	3720	
HTHMQR/L-2-SDS	1½ - 4 1/16	3 3/16	30°-60°	34-¼"x3" SDS	4-¼"x2½" SDS	4-¼"x1½" SDS	1470	490	1960	6190	2065	8255	1265	420	1685	4865	1620	6485	

1. Tabulated allowable loads must be selected based on duration of load as permitted by the applicable building code.
2. The uplift loads have been increased for wind or earthquake loading with no further increase allowed. Reduce when other load durations govern.
3. Specify W₁ where applicable and Hip Skew Angle.
4. Connector must be installed centered on minimum 2x8 vertical web.
5. A minimum 2-ply carrying member is required for the tabulated loads.
6. Carrying truss plies must be adequately fastened together as determined by Designer.
7. Truss chord cross-grain tension may limit allowable loads as determined by the Designer in accordance with ANSI/TPI 1-2007.

8. Tabulated allowable loads for three-member configurations assume that each hip carries 40% of the total load and the jack carries 20% of the total load. Tabulated allowable loads for single hip-jack configurations assume that 75% of the total load is distributed to the hip and 25% to the jack.
9. Simpson Strong-Tie® Strong-Drive® SDS Heavy-Duty Connector screws are permitted to be installed through metal truss plates as approved by the Truss Designer, provided the requirements of ANSI/TPI 1-2007 Section 7.5.3.4 and 8.9.2 are met (pre-drilling required through the plate using a maximum of 5/32" bit).
10. ¼" x 2½" Strong-Drive SDS Heavy-Duty Connector screw may be substituted for the ¼" x 3" Strong-Drive SDS Heavy-Duty Connector screw provided with the HTHMQ with no load reduction. Back-to-back installations require a 3-ply minimum girder.

ALTERNATE INSTALLATIONS

- Block(s) should be of similar size/grade as the truss member to which it is attached. Blocking should be designed to act as one unit with the truss members.
- Block(s) should be of sufficient size to accept all carried/carrying member nails, and develop full seat bearing as specified in Simpson Strong-Tie publications.
- Truss Designer is to confirm blocking size/grade, fasteners required and application.
- Fasteners used to attach the additional blocking should be independent of the truss hanger fasteners.

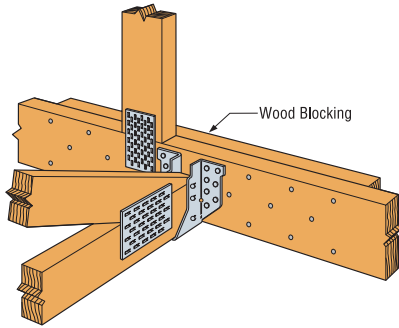

1 Use of Wood Blocking to Achieve the Full Design Load Value of a Face Mount Hanger Attached to a Single Ply Carrying (Girder) Member. (Block designed by Engineer of Record or Truss Designer)

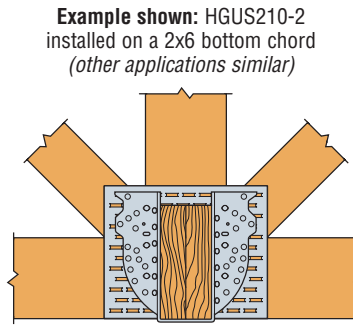

2 Connection Design to Achieve Specified Nailing of a Face Mount Hanger at a Panel Point.

Nails located in joints formed by the intersection of wood members or with edge or end distances less than suggested by NDS have no load resistance. The hanger allowable load value shall be reduced by the nail shear value for each header nail less than the specified quantity. Connection shall be approved by the Truss Designer.

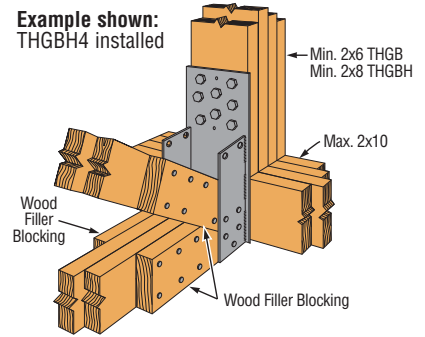

3 Use of Wood Filler Blocking for Carried Member Width Less than Hanger Width. (Block designed by Designer or Truss Designer)

MSCPT Multiple Truss Hangers

The MSCPT is a high capacity, top flange welded hanger designed to carry 2 or 3 trusses in a terminal hip installation. The top flange is notched at the center to accommodate vertical and diagonal web members in the girder truss.

MATERIAL: Top flange—3 gauge; stirrup—11 gauge (MSCPT2, MSCPT2N), 7 gauge (MSCPT2-2, MSCPT2-2N)

FINISH: Simpson Strong-Tie® gray paint

INSTALLATION: • Use all specified fasteners. See General Notes.

- The total load must be evenly distributed about the centerline to avoid eccentric loading.
- All multiple members must be fastened together to act as a single unit.
- Minimum vertical carrying member sizes are 2x6 for MSCPT2 and MSCPT2N, and 2x8 for MSCPT2-2 and MSCPT2-2N.
- Minimum carrying member bottom chord is a 2-ply 2x6.

OPTIONS: • H_1 and H_2 should be equal to the bottom chord depth of the carrying member in order to maintain all members flush at the bottom.
• Hip stirrups can be skewed from 25° to 45°.
• The W_1 and W_2 of the MSCPT2 may be increased up to 3 $\frac{1}{8}$ ", provided the stirrups' configuration remains symmetrical.

CODES: See page 12 for Code Reference Key Chart.

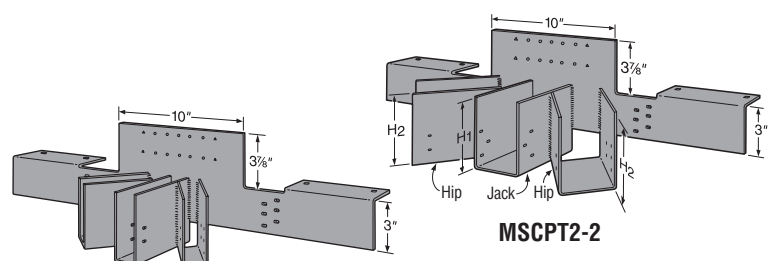

MSCPT2

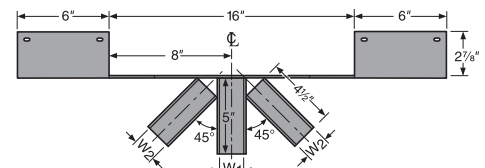

MSCPT2 Top View (MSCPT2-2 similar)

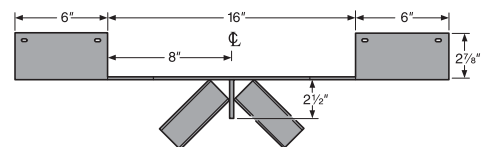

MSCPT2N Top View (MSCPT2-2N similar)

Model No.	Dimensions			Fasteners			DF/SP Allowable Loads ^{1,2}						Code Ref.
	W_1 & W_2	H_1 & H_2 (min.)	TF	Header	Joists	Uplift (160)			Floor/Snow/Roof/Wind (100/115/125/160)				
						Hip	Jack	Total	Hip	Jack	Total		
MSCPT2	1 $\frac{1}{8}$ "	5 $\frac{1}{4}$ "	2 $\frac{1}{2}$ "	26-16d	18-10dx1 $\frac{1}{2}$ "	750	370	1870	3145	1570	7860	F23	
MSCPT2N	1 $\frac{1}{8}$ "	5 $\frac{1}{4}$ "	2 $\frac{1}{2}$ "	26-16d	14-10dx1 $\frac{1}{2}$ "	750	—	1500	3930	—	7860		
MSCPT2-2	3 $\frac{3}{16}$ "	5 $\frac{1}{4}$ "	2 $\frac{1}{2}$ "	30-16d	20-10d	750	370	1870	3470	1735	8675		
MSCPT2-2N	3 $\frac{3}{16}$ "	5 $\frac{1}{4}$ "	2 $\frac{1}{2}$ "	30-16d	14-10d	750	—	1500	4335	—	8675		

Model No.	Dimensions			Fasteners			SPF/HF Allowable Loads ^{1,2}						Code Ref.
	W_1 & W_2	H_1 & H_2 (min.)	TF	Header	Joists	Uplift (160)			Floor/Snow/Roof/Wind (100/115/125/160)				
						Hip	Jack	Total	Hip	Jack	Total		
MSCPT2	1 $\frac{1}{8}$ "	5 $\frac{1}{4}$ "	2 $\frac{1}{2}$ "	26-16d	18-10dx1 $\frac{1}{2}$ "	645	320	1610	3000	1500	7500	F23	
MSCPT2N	1 $\frac{1}{8}$ "	5 $\frac{1}{4}$ "	2 $\frac{1}{2}$ "	26-16d	14-10dx1 $\frac{1}{2}$ "	645	—	1290	3470	—	6940		
MSCPT2-2	3 $\frac{3}{16}$ "	5 $\frac{1}{4}$ "	2 $\frac{1}{2}$ "	30-16d	20-10d	645	320	1610	3000	1500	7500		
MSCPT2-2N	3 $\frac{3}{16}$ "	5 $\frac{1}{4}$ "	2 $\frac{1}{2}$ "	30-16d	14-10d	645	—	1290	3750	—	7500		

1. For MSCPT2 and MSCPT2-2 models, allowable hip loads are 0.40 x Total Loads, and Jack Loads are 0.20 x Total Loads.
2. Uplift loads have been increased for wind or earthquake loading with no further increase allowed; reduce where other loads govern.
3. Wind (160) is a download rating.
4. **NAILS:** 16d = 0.162" dia. x 3 $\frac{1}{2}$ " long, 10d = 0.148" dia. x 3" long, 10dx1 $\frac{1}{2}$ " = 0.148" dia. x 1 $\frac{1}{2}$ " long. See pages 22-23 for other nail sizes and information.

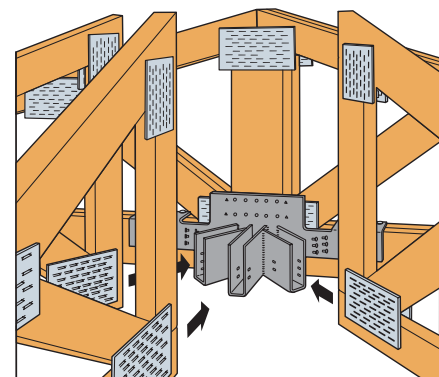

Typical MSCPT2 Installation

AHEP Adjustable Hip-End Purlin

For wood and cold-formed steel trusses, the Simpson Strong-Tie® AHEP is a structural purlin that also serves as an installation lateral restraint and spacer during the truss erection process. The AHEP attaches to the leading edge of step-down hip trusses, eliminating the need for drop-top chords, 2x lumber or gable end fillers. The interlocking design of the AHEP allows them to install linearly, aligned with the end jacks, to maintain framing spacing from eave to hip or peak. Roof sheathing/decking attaches directly to the purlin with knurled pneumatic fasteners or low-profile head, self-drilling screws. Adjustable in length, the AHEP is designed to accommodate a pitch range of 3/12 to 9/12 as a structural purlin and up to 12/12 as an installation lateral restraint and spacer.

- FEATURES:**
- A structural purlin to which sheathing can be directly attached – no need to remove temporary bracing
 - Accurately spaces the installed trusses and helps meet the temporary top-chord lateral restraint recommendations of WTCA/TPI BCSI on step-down hip ends
 - Adjustable in length to accommodate a wide pitch range

MATERIAL: 20 gauge (33 mil) **FINISH:** Galvanized

- INSTALLATION:**
- Use all specified fasteners; see General Notes.
 - Prior to installation, the AHEP must be set to the proper length and the two tubes fastened together with four #10x¾" self-drilling screws through the round holes in the side flanges for pitches between 3/12 and 9/12; and in the triangular and upper round hole when the AHEP will be used as an installation restraint and spacer at pitches 9/12 up to 12/12.
 - For trusses spaced 24" o.c., the pitch markings on the inner tube may be used to line up the tubes to the correct length for a given pitch. For other spacings, the length of the AHEP must be set to the calculated sloping length (*from leading edge to leading edge of the framing members*).
 - To install the AHEPs on wood trusses, use four 10d (.148"x3") nails. The two nails at the bottom of the part (*the yoke end*) must be clinched.
 - Sheathing is attached to the AHEP with knurled pneumatic fasteners or low-profile-head, self-drilling screws.
 - For efficiency, the AHEPs should be installed in line with the end jacks so that framing alignment can be maintained from eave to hip/ridge.

CODES: See page 12 for Code Reference Key Chart.

Online Calculator for AHEP Installation

A Web-based calculator is available to help Designers check AHEP applicability based on the actual hip-end roof pitch, input live and dead loads, truss and purlin spacing and the selected sheathing and deflection criteria. To view the calculator, visit www.strongtie.com/webapps/ahep.

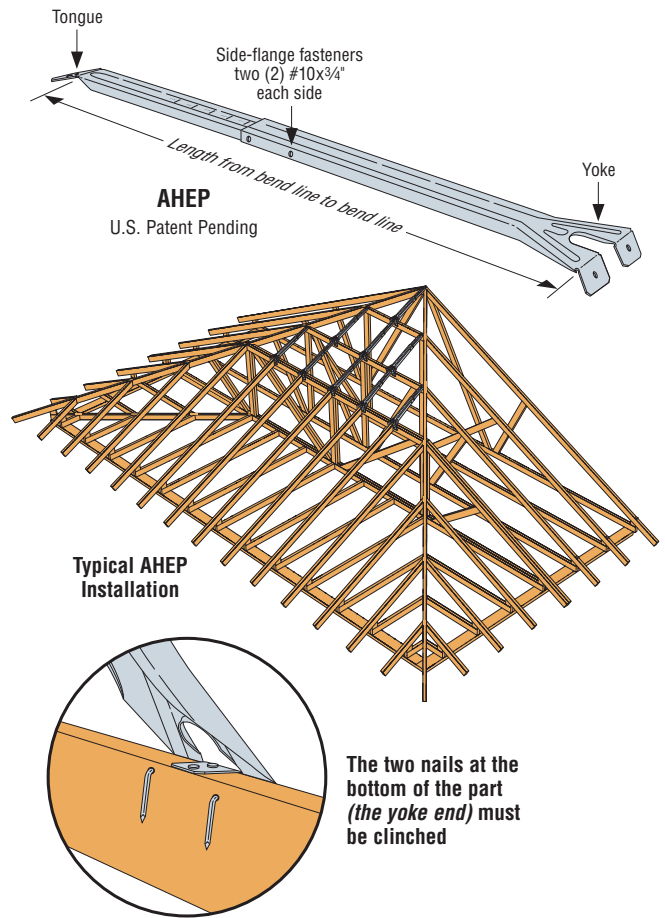

Model No.	Fasteners		Sheathing Option	Allowable Down Loads						Code Ref.
	AHEP Side Flanges	To Hip Trusses		3/12 Pitch		3.1/12 Pitch		9/12 Pitch		
				L/180	¾"	L/180	¾"	L/180	¾"	
AHEP	4 - #10	4 - 10d	None	180	240	180	240	135	150	I13, F12
			1½" (Min.) Wood Sheathing	250	345	210	275	160	175	

1. No load duration increase allowed.
2. Allowable loads apply to wood with a specific gravity of 0.42 or greater.
3. Designer shall insure attached members are adequately designed to resist applied loads.
4. Straight line interpolation can be used to determine allowable loads for pitches between 3.1/12 and 9/12.
5. **Nails:** 10d = 0.148 dia. x 3" long.
Screws: #10 = #10 x ¾" long self-drilling screws.
See pages 22-23 for other nail sizes and information.

TSF Truss Spacer

The TSF is a fast and accurate method for spacing trusses that eliminates layout marking of top plates and can be left in place under the sheathing. Accuracy is improved, spacing errors are minimized, and it is easy to use.

MATERIAL: 24 gauge **FINISH:** Galvanized

INSTALLATION: • See Installation Sequence below.

- TSF Truss Spacers do not provide bracing of any kind and are not structural members. The TSF is for spacing only. Refer to instructions from architect, engineer, truss manufacturer or other for bracing and installation information.

CODES: See page 12 for Code Reference Key Chart.

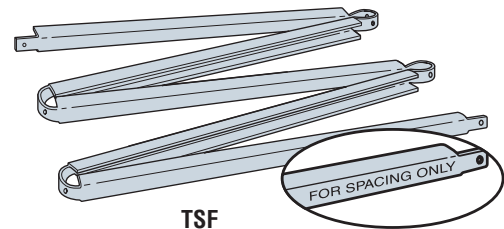

Model No.	Dimensions			Code Ref.
	W	O.C. Spacing	Total Length	
TSF2-16	1½	16	8'	180
TSF2-24	1½	24	10'	

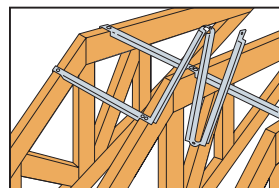

STEP 1
Nail starting notch to first member.

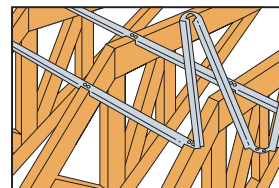

STEP 2
As each successive member is positioned, unfold TSF to next notch. The notch teeth grip member and align it for nailing.

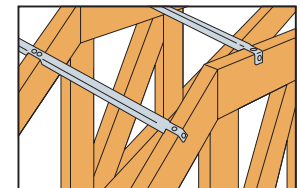

STEP 3
If spacer does not align with end truss, break spacer off at notch. Then, hammer spacer flat, fold it under and nail.

TSBR Truss Spacer-Restraint

The Simpson Strong-Tie® TSBR truss spacer-restraint is a time-saving lateral-restraint product for wood and CFS framing that improves quality and safety while helping to meet the prescriptive recommendations of the WTCA/TPI. Easier to install than wood bracing, the TSBR firmly grips the trusses, capturing on-center spacing and keeping them vertical and plumb after placement, resulting in a better truss installation. The unique design eliminates additional time spent measuring truss spacing and laying out temporary lateral bracing. And once installed, the TSBR can remain in place to be sheathed over, thereby eliminating the need to remove temporary bracing and creating a safer, more stable work platform.

- FEATURES:**
- Enables the quick and accurate spacing of trusses without measuring or adjusting
 - Helps meet prescriptive temporary bracing recommendations of the BCSI
 - Easily “grabs” onto the truss – may be put in place with one hand
 - Stays in place during sheathing, saving time and making the roof more stable for workers
 - Installs in less time and requires less total bracing material than prescriptive wood bracing methods – reducing labor costs
 - The TSBR is a direct replacement for the TSB Truss Spacer Bracer.

MATERIAL: 22 gauge **FINISH:** Galvanized

INSTALLATION: • Use all specified fasteners; see General Notes.

- TSBR lateral restraint locations are as recommended in Table B2-1 of WTCA/TPI BCSI or the BCSI B2 Summary Sheet. For more information see the Simpson Strong-Tie Wood Truss Bracing and Restraint Guide (F-TSBR22).

CODES: See page 12 for Code Reference Key Chart.

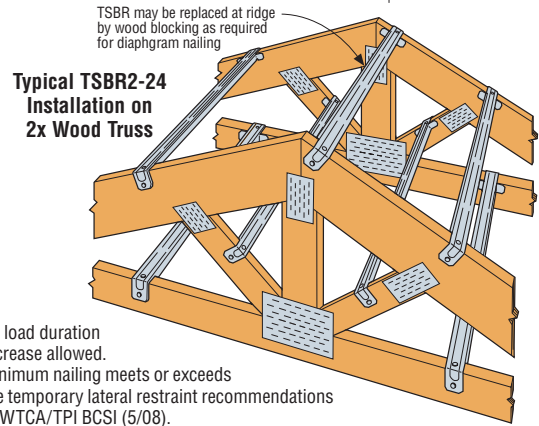
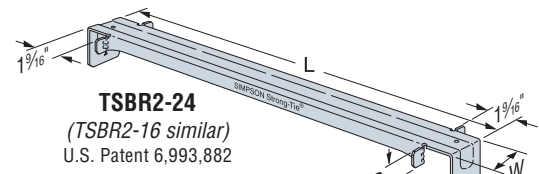

1. No load duration increase allowed.
2. Minimum nailing meets or exceeds the temporary lateral restraint recommendations of WTCA/TPI BCSI (5/08).
3. **NAILS:** 10dx1 1/2 = 0.148" dia. x 1 1/2" long, 10d = 0.148" dia. x 3" long. See pages 22-23 for other nail sizes and information.

Model No.	Dimensions (in)			Fasteners (Total)	Allowable Loads (lbs)				Code Ref.
	L	W	D		DF/SP		SPF/HF		
					Compression	Tension	Compression	Tension	
TSBR2-16 ² (Min)	17 1/2	1 1/4	1 1/4	2-10d	540	180	465	155	170
TSBR2-16 (Max)	17 1/2	1 1/4	1 1/4	4-10dx1 1/2	540	455	465	390	
TSBR2-24 ² (Min)	25 1/2	1 1/4	1	2-10d	500	180	430	155	I13,
TSBR2-24 (Max)	25 1/2	1 1/4	1	4-10dx1 1/2	500	455	430	390	F12

TBD22 Diagonal Brace

The TBD22 diagonal truss brace offers a time-saving substitute for 2x4 diagonal bracing that helps meet the recommendations of WTCA/TPI BCSI. The TBD travels in a box like a flat strap, and is formed into an A-shape as it is pulled from the carton to provide rigidity and prevent sagging between trusses during installation. As it is fastened to the trusses the brace flattens, allowing sheathing to be installed right over it and saving the time typically needed to remove 2x4 bracing.

When installed on the top and bottom chords as well as the web planes, the TBD captures the lateral construction and wind forces delivered by the TSBR truss spacer restraints and transfers it diagonally in tension to the edge of the braced-truss system. When used in conjunction with the TSBR, the TBD22 meets or exceeds the the recommendations set forth by the WTCA/TPI BCSI.

- FEATURES:**
- Helps meet prescriptive temporary bracing recommendations of the WTCA/TPI BCSI.
 - Rigid A-shape design virtually eliminates sagging between trusses spaced 16"-24" on center.
 - Can be sheathed over after installation, no need to remove bracing.
 - Dimpled nailing grid allows installation with standard pneumatic fasteners.
 - 160' of bracing in an easy-to-handle carton.

MATERIAL: 22 gauge **FINISH:** Galvanized

INSTALLATION: • Use all specified fasteners; see General Notes.

- Strap does not have holes for fasteners. Nails shall be installed in the dimpled areas and placed to maintain a minimum of 1/4" strap edge distance and a minimum of 1/2" center to center distance. Nails should be installed in the center of the lumber narrow face and with a minimum edge distance of 1" on the lumber wide face.
- TBD22 straps span diagonally at approximately 45°.
- Strap shall not be slack, but tight and ready to engage in tension.
- To resist construction forces, diagonal X-bracing is required at each end and every 10 truss spaces (20' max). Refer to WTCA/TPI BCSI for additional information.
- At the end of the TBD braces trusses shall be laterally braced to resist out of plane forces.
- Bracing locations shown in the drawing are recommendations for temporary bracing only. Installation of TBD braces for permanent lateral bracing shall be per the Building Designer.

CODES: See page 12 for Code Reference Key Chart.

Model No.	Fasteners		Allowable Tension Loads		Code Ref.
	Strap Ends	Intermediate Trusses	DF/SP	SPF/HF	
TBD22 ² (Min)	1-10dx1 1/2 in face and 1-10dx1 1/2 in edge	1-10dx1 1/2	430	390	170
TBD22 (Max)	2-10dx1 1/2 in face and 1-10dx1 1/2 in edge	1-10dx1 1/2	565	520	

1. Allowable loads have been increased for construction and wind loading with no further increase allowed.
2. Minimum nailing meets or exceeds the temporary bracing recommendations of WTCA/TPI BCSI.
3. **NAILS:** 10dx1 1/2 = 0.148" dia. x 1 1/2" long. See pages 22-23 for other nail sizes and information.

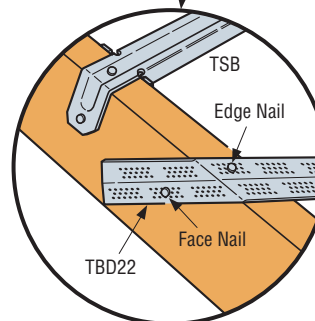
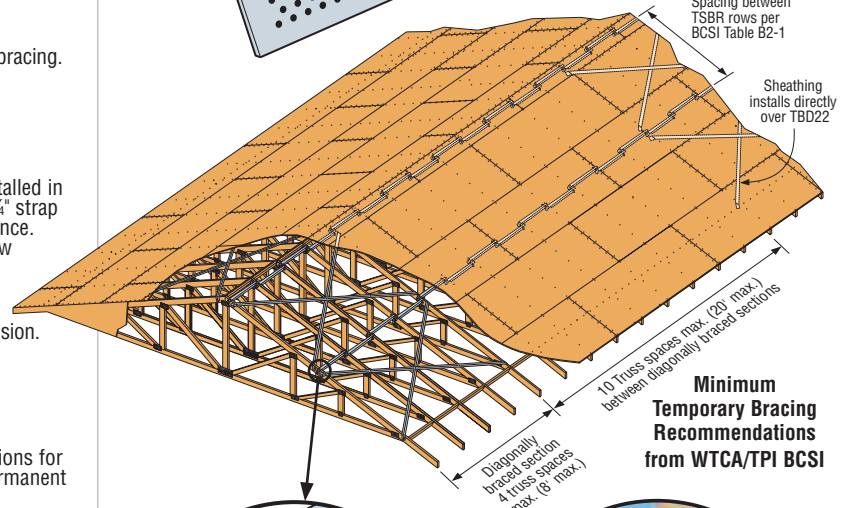
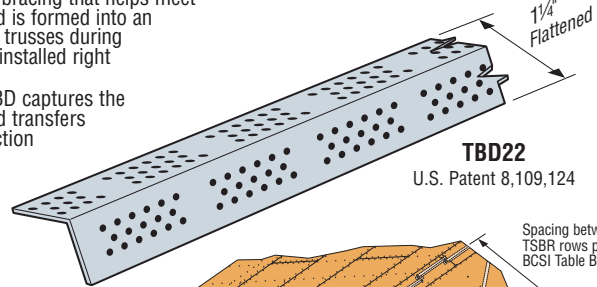

Typical TBD22 Top Chord Installation with Minimum Nailing



TBD22 Dispenser Detail

TBE Truss Bearing Enhancers

The TBE transfers load from the truss or girder to plates for bearing-limited conditions and provides exceptional uplift capacity. Replaces nail-on scabs that provide lower load transfer, or in some cases, an additional ply when needed for bearing. One size works with any number of girder plies.

The table lists allowable loads for TBE4 used on 2x4 and TBE6 used on 2x6 top plates. The table gives the different loads calculated for TBE with and without wood bearing. See Fastener Schedule below and page 168 for Alternate Installation.

MATERIAL: 18 gauge

FINISH: Galvanized. See Corrosion Information, pages 13-15.

INSTALLATION: • Use all specified fasteners. See General Notes.

- TBE must be installed in pairs.
- Top plate size is 2x4 for TBE4, 2x6 for TBE6. Use alternate installation for TBE4 and TBE6 on larger plates or pre-sheathed walls. See page 168.

CODES: See page 12 for Code Reference Key Chart.

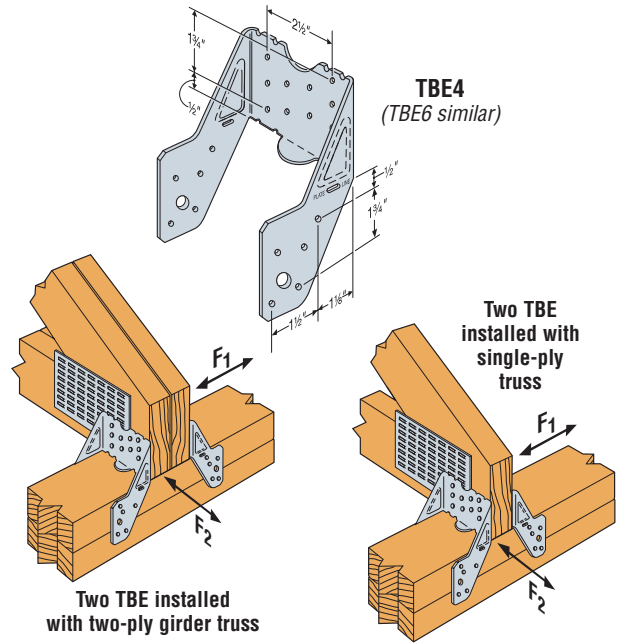

TBE FASTENER SCHEDULE

Model No.	Truss Plies	Fasteners per each TBE	
		Rafter	Plate
TBE4	1	10-10dx1 1/2	10-10dx1 1/2
	2 or more	10-10d	10-10d
TBE6	1	10-10dx1 1/2	10-10dx1 1/2
	2 or more	10-10d	10-10d

NAILS:

10d = 0.148" dia. x 3" long,
10dx1 1/2 = 0.148" dia. x 1 1/2" long.
See pages 22-23 for other nail sizes and information.

Model No.	Wall Top Plate	Top Plate or Truss Wood Species ²	No. of Truss Plies	Allowable Loads ^{1,2,3}										Equivalent Bearing Length ⁷ of TBE and Top Plate (in.)				Code Ref.	
				Uplift	Download				Lateral (160)		(100)	(115)	(125)	(160)					
					(160)	(100)	(115)	(125)	(160)	(100)					(115)	(125)	(160)		F ₁
TBE4	2x4	Douglas Fir Larch	1	850	1820	2095	2230	2230	5100	5375	5510	5510	400	1000	5.44	5.73	5.88	5.88	113, F12
			2	850	2220	2230	2230	2230	8785	8795	8795	8795	400	1000	4.68	4.69	4.69	4.69	
			3	850	2220	2230	2230	2230	12065	12075	12075	12075	400	1000	4.29	4.29	4.29	4.29	
			4	850	2220	2230	2230	2230	15345	15355	15355	15355	400	1000	4.09	4.09	4.09	4.09	
		Southern Pine	1	850	1820	2095	2230	2230	4785	5060	5195	5195	400	1000	5.65	5.97	6.13	6.13	
			2	850	2220	2230	2230	2230	8155	8165	8165	8165	400	1000	4.81	4.82	4.82	4.82	
			3	850	2220	2230	2230	2230	11120	11130	11130	11130	400	1000	4.37	4.38	4.38	4.38	
			4	850	2220	2230	2230	2230	14085	14095	14095	14095	400	1000	4.15	4.16	4.16	4.16	
		Spruce-Pine-Fir	1	850	1560	1795	1950	2080	3790	4025	4180	4310	375	1000	5.95	6.32	6.56	6.76	
			2	850	1920	2100	2100	2100	6385	6565	6565	6565	375	1000	5.01	5.15	5.15	5.15	
			3	850	1920	2100	2100	2100	8615	8795	8795	8795	375	1000	4.50	4.60	4.60	4.60	
			4	850	1920	2100	2100	2100	10845	11025	11025	11025	375	1000	4.25	4.32	4.32	4.32	
		Hem Fir	1	850	1560	1795	1950	2080	3685	3920	4075	4205	375	1000	6.07	6.45	6.71	6.92	
			2	850	1920	2100	2100	2100	6175	6355	6355	6355	375	1000	5.08	5.23	5.23	5.23	
			3	850	1920	2100	2100	2100	8300	8480	8480	8480	375	1000	4.55	4.65	4.65	4.65	
			4	850	1920	2100	2100	2100	10425	10605	10605	10605	375	1000	4.29	4.36	4.36	4.36	
TBE6	2x6	Douglas Fir Larch	1	935	1820	2095	2275	2425	6975	7250	7430	7580	300	1000	7.44	7.73	7.93	8.09	
			2	935	2220	2555	2735	2735	12535	12870	13050	13050	300	1000	6.68	6.86	6.96	6.96	
			3	935	2220	2555	2735	2735	17690	18025	18205	18205	300	1000	6.29	6.41	6.47	6.47	
			4	935	2220	2555	2735	2735	22845	23180	23360	23360	300	1000	6.09	6.71	6.82	6.90	
		Southern Pine	1	935	1820	2095	2275	2425	6480	6755	6935	7085	300	1000	7.65	7.97	8.18	8.36	
			2	935	2220	2555	2735	2735	11545	11880	12060	12060	300	1000	6.81	7.01	7.11	7.11	
			3	935	2220	2555	2735	2735	16205	16540	16720	16720	300	1000	6.37	6.50	6.58	6.58	
			4	935	2220	2555	2735	2735	20865	21200	21380	21380	300	1000	6.15	6.25	6.31	6.31	
		Spruce-Pine-Fir	1	935	1560	1795	1950	2080	5065	5300	5455	5585	300	965	7.95	8.32	8.55	8.76	
			2	935	1920	2210	2400	2560	8935	9225	9415	9575	300	965	7.01	7.23	7.38	7.51	
			3	935	1920	2210	2400	2560	12440	12730	12920	13080	300	965	6.50	6.66	6.75	6.84	
			4	935	1920	2210	2400	2560	15945	16235	16425	16585	300	965	6.25	6.37	6.44	6.50	
		Hem Fir	1	935	1560	1795	1950	2080	4900	5135	5290	5420	300	965	8.07	8.45	8.70	8.92	
			2	935	1920	2210	2400	2560	8605	8895	9085	9245	300	965	7.08	7.32	7.48	7.61	
			3	935	1920	2210	2400	2560	11945	12235	12485	12645	300	965	6.55	7.32	7.48	7.61	
			4	935	1920	2210	2400	2560	15285	15575	15765	15925	300	965	6.29	6.41	6.49	6.55	

1. Loads are for a pair of TBEs.
2. When truss chord wood species is different than the wall top plate wood species, choose the tabulated allowable loads based on the species with the lower tabulated download capacity.
3. Uplift and lateral loads have been increased for wind or earthquake loading with no further increase allowed; reduce where other loads govern.

4. Allowable loads are determined only by nail shear calculations or tests of the metal connectors based on the lowest of 0.125" of deflection or the ultimate load with a 3 times factor of safety. The attached wood members must be designed to withstand the loads imposed by the nails.
5. Perpendicular to Plate loads are reduced for Alternate Installation.
6. Parallel to Plate loads are not reduced for Alternate Installation.
7. Equivalent Top Plate Bearing Width is the actual top plate width (TBE4 = 3 1/2", TBE6 = 5 1/2") plus the enhanced bearing width provided by the TBE.

TBE Truss Bearing Enhancers

ALTERNATE INSTALLATION

(See illustrations at right)

Model No.	Alternate Installation Allowable Loads ^{5,6} Perpendicular to Plate			
	DF/SP (160)		SPF/HF (160)	
	F ₂	F ₃	F ₂	F ₃
TBE4	1000	300	860	260
TBE6				

1. Use full table loads for uplift and parallel-to-plate allowable loads.
2. Download capacities are 0.80 of table loads.
3. See additional footnotes on page 167.

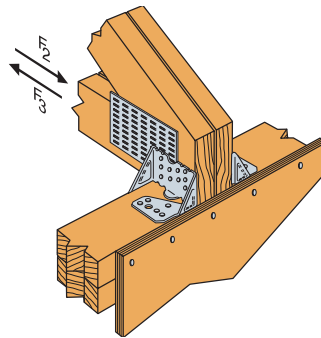

Pre-sheathed shearwall. Bend tab along slot and nail one leg to top of the plate.

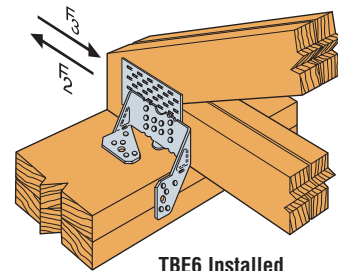

TBE6 Installed on Double 2x8 Top Plate

Alternate Installation Allowable Down Loads are 0.80 and Allowable Uplift Loads are 1.0 of the TBE only table loads on page 167.

TC Truss Connectors

The TC truss connector is an ideal connector for scissor trusses and can allow horizontal movement up to 1/4". The TC also attaches plated trusses to top plates or sill plates to resist uplift forces. Typically used on one or both ends of truss as determined by the Designer.

MATERIAL: 16 gauge **FINISH:** Galvanized

INSTALLATION:

- Use all specified fasteners. See General Notes.
- Drive 10d nails into the truss at the inside end of the slotted holes (*inside end is towards the center of the truss and clinch on back side*). Do not seat these nails into the truss—allow room under the nail head for movement of the truss with respect to the wall.
- After installation of roofing materials nails may be required to be fully seated into the truss. (*As required by the Designer or Truss Designer.*)

Optional TC Installation

- Bend one flange up 90°. Drive specified nails into the top and face of the top plates or install Titen® screws into the top and face of masonry wall. See optional load tables and installation details.

CODES: See page 12 for Code Reference Key Chart.

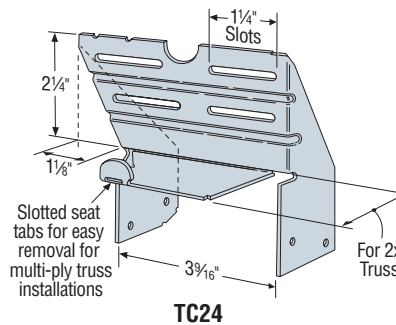

TC24

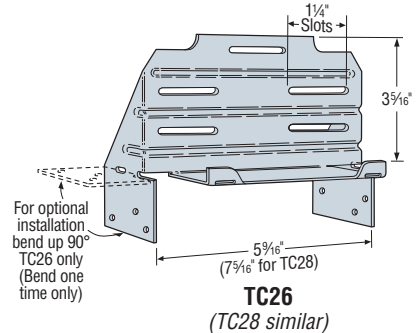

TC26 (TC28 similar)

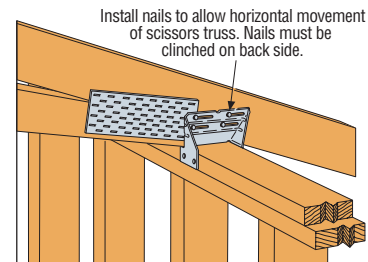

Typical TC24 Installation

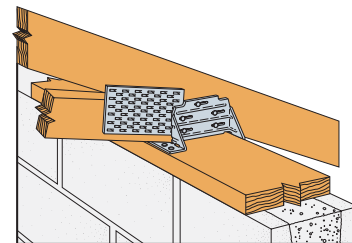

Optional TC26 Installation for Grouted Concrete Block using a Wood Nailer (8", 10", 12" Wall Installation similar)

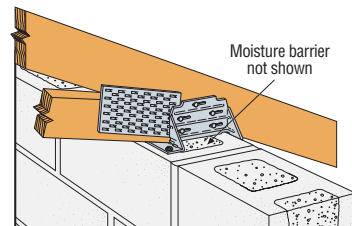

Optional TC26 Installation for Grouted Concrete Block using Titen Screws

Model No.	Fasteners		DF/SP Allowable Loads	SPF/HF Allowable Loads	Code Ref.
	Truss	Plate	Uplift (160)	Uplift (160)	
TC24	4-10d	4-10d	400	345	I13, F12
TC26	5-10d	6-10d	665	570	
TC28	5-10d	6-10d	665	570	

See footnotes below.

OPTIONAL TC INSTALLATION TABLE

Model No.	Fasteners		DF/SP Allowable Loads	SPF/HF Allowable Loads	Masonry Allowable Loads	Code Ref.
	Truss	Plate	Uplift (160)	Uplift (160)	Uplift (160)	
TC26	5-10dx1 1/2	6-10dx1 1/2	430	350	—	I13, F12
	5-10d	6-10d	450	390	—	
	5-10d	6-3/16x2 1/4 Titen	—	—	195	

1. Loads have been increased for wind or earthquake loading with no further increase allowed; reduce where other loads govern.
2. Grout strength is 2000 psi minimum.
3. Nail values based on single 2x truss. 10d joist nails must be clinched.
4. Optional TC26 installation with 10d nails requires minimum 3" top plate thickness.
5. **NAILS:** 10d = 0.148" dia. x 3" long, 10dx1 1/2 = 0.148" dia. x 1 1/2" long. See pages 22-23 for other nail sizes and information.

HTC Heavy Truss Clips

For alignment control between a roof truss and nonbearing walls; the 2½" slot permits vertical truss chord movement when loads are applied.

MATERIAL: 18 gauge

FINISH: Galvanized

INSTALLATION: • Use all specified fasteners; see General Notes.

- The HTC has a 2½" slot to accommodate truss movement
- This connector has high lateral capacity.
- The S/HTC is available for steel truss applications.

CODES: See page 12 for Code Reference Key Chart.

Model No.	Dimensions			Fasteners		Allowable Loads ¹ (160)				Code Ref.
	Top Plate	Base	Slot	Without Gap ²		With 1¼" Gap ³		F ₁	F ₂	
				F ₁	F ₂	F ₁	F ₂			
HTC4	2x4 Plate	6-10d	3-10d	390	305	85	280	170		
	2x6 Plate	6-10d	3-10d	485	280	155	280			

1. Loads may not be increased for short-term loading.
2. Truss or rafter must be bearing on top plate to achieve the allowable loads under "WITHOUT GAP."
3. When installed with maximum 1¼" space between rafter or truss and top plate use loads under "WITH 1¼" GAP." Where loads are not required, space is not limited to 1¼".
4. **NAILS:** 10d = 0.148" dia. x 3" long.
See pages 22-23 for other nail sizes and information.

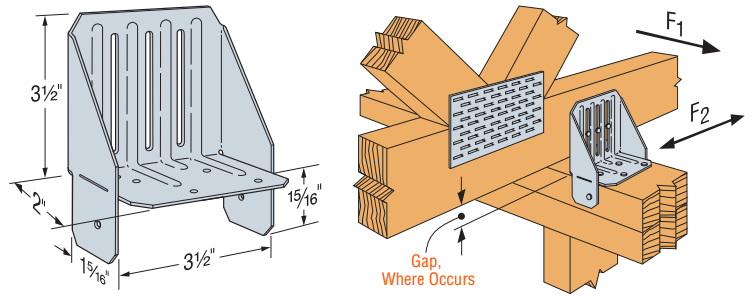

HTC4

Typical HTC4 Installation on a 2x4 Plate

Allow 1/16" gap between nail head and truss clip to help prevent squeaking

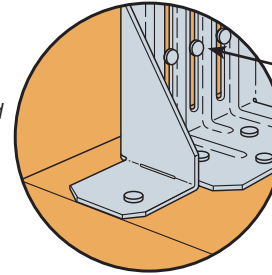

Typical HTC4 Installation on a 2x6 or Larger Plate

Nails should not be driven completely flush against the connector, to allow vertical truss movement.

STC/STCT/DTC Roof Truss Clips

For alignment control between a roof truss and nonbearing walls; the 1½" slot permits vertical truss chord movement when loads are applied.

MATERIAL: 18 gauge

FINISH: Galvanized

INSTALLATION: • Use all specified fasteners; see General Notes.

- Use STC or DTC depending on required loads. STC, installed with Drywall Stop (DS), helps prevent fasteners tearing through the ceiling sheetrock (see illustration).
- Use STCT where truss or rafter is separated from the top plate of the nonbearing wall.
- Install slot nails in the middle of the slot.
- Products not intended for floor applications due to the frequency of floor joist deflections and potential for squeaks.

CODES: See page 12 for Code Reference Key Chart.

Model No.	Fasteners		Allowable Loads ¹ (160)						Code Ref.
	Base	Slot	Without Gap ²		¼" Max Gap		¼" < Gap ≤ ½"		
			F ₁	F ₂	F ₁	F ₂	F ₁	F ₂	
STC	2-8d	1-8d	85	55	35	35	30	40	170
STCT	2-8d	1-8d	—	—	—	—	—	—	
DTC	4-8d	2-8d	125	210	85	135	55	70	

1. Loads may not be increased for short-term loading.
2. Truss or rafter must be bearing on top plate to achieve the allowable loads under "WITHOUT GAP."
3. Clips are required on both sides of the truss to achieve F₁ loads in both directions (stagger parts to avoid nail interferences).
4. **NAILS:** 8d = 0.131" dia. x 2½" long.
See pages 22-23 for other nail sizes and information.

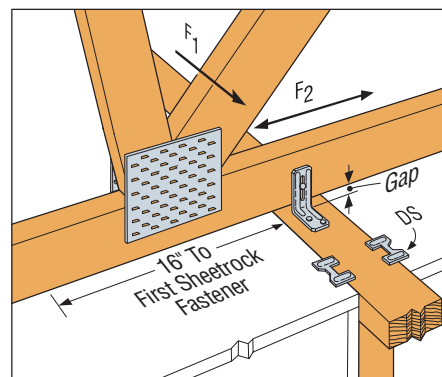
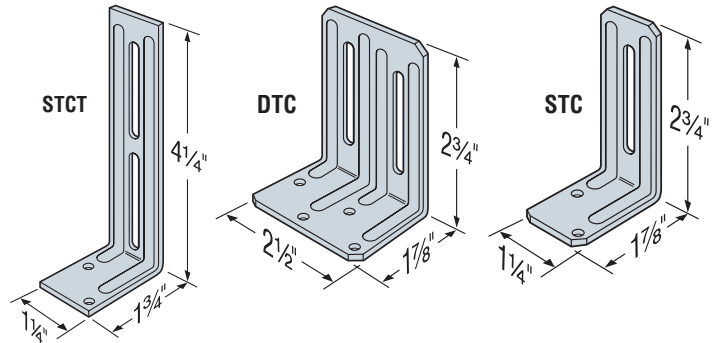

Typical STC Installation with DS

To allow vertical truss movement, nails should not be driven completely flush against the connector.

VTCR Single-Sided Valley Truss Clip



This product is preferable to similar connectors because of a) easier installation, b) higher loads, c) lower installed cost, or a combination of these features.

The VTCR is single-sided valley truss clip that provides a positive connection between the valley truss and the supporting framing below. Installed on top of the roof sheathing, it eliminates the need to add a support wedge under the valley truss or to bevel the bottom chord to match the roof pitch.

- Single-sided for new construction or retrofit applications – can be installed after the valley truss is set in place
- Accommodates pitches from 0/12 to 12/12
- Can be installed on either beveled or non-beveled bottom chords
- Installs with nails or Simpson Strong-Tie® Strong-Drive® SD Connector screws

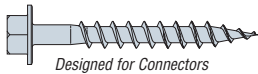

MATERIAL: 18 gauge **FINISH:** Galvanized

INSTALLATION:

- The dome holes assist in installing the fasteners into the supporting framing at approximately 45°.

CODES: See page 12 for Code Reference Key Chart.

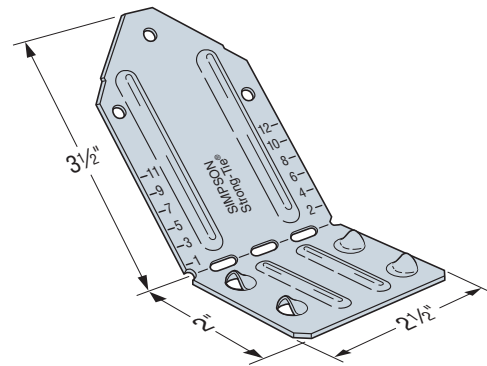

These products are approved for installation with the Strong-Drive® SD Connector screw. See page 27 for more information.

Model No.	Fasteners		Supporting Roof Pitch	DF/SP Allowable Loads		SPF/HF Allowable Loads		Code Ref.
	Supporting Framing	Valley Truss		Uplift ³ (160)	Download ⁵ (100/115/125/160)	Uplift ³ (160)	Download ⁶ (100/115/125/160)	
VTCR	4-10d	3-10dx1½"	< 4/12	370	790	320	655	I13, F12
			4/12 to 12/12	370	790	320	655	
	4-SD #9x2½"	3-SD #9x1½"	< 4/12	390	790	335	655	
			4/12 to 12/12	500	790	430	655	

1. Uplift loads have been increased 60% for wind or earthquake loading with no further increase allowed.
2. Loads are based on installation over 7/16" or 1/32" sheathing. For installation over 1/32" or 5/8" sheathing, allowable uplift loads are 285 lbs. (DF/SP) and 245 lbs. (SPF/HF) when installed with nails, or 370 lbs. (DF/SP) and 320 lbs. (SPF/HF) when installed with screws.
3. When attached directly to the supporting framing with either screws or nails, the allowable uplift for pitches less than 4/12 is 240 lbs. (DF/SP) and 205 lbs. (SPF/HF). For pitches 4/12 to 12/12, use the tabulated uplift loads.
4. Allowable uplift loads are based on the lower of the test loads at 3/16" deflection or the ultimate load divided by 3.
5. Southern pine allowable download is 750 lbs.
6. Hem fir allowable download is 625 lbs.
7. When the valley truss and supporting framing are of different species, use the lower tabulated values.
8. **NAILS:** 10d = 0.148" dia. x 3" long, 10dx1½" = 0.148" dia. x 1½" long. See pages 22-23 for other nail sizes and information.
9. **SCREWS:** SD #9x1½" (model SD9112) = 0.131" dia. x 1½" long, SD #9x2½" (model SD9212) = 0.131" dia. x 2½" long.

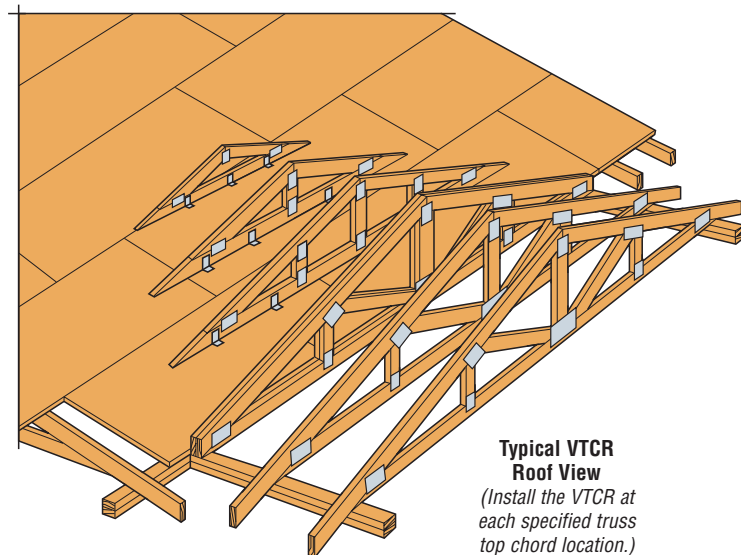
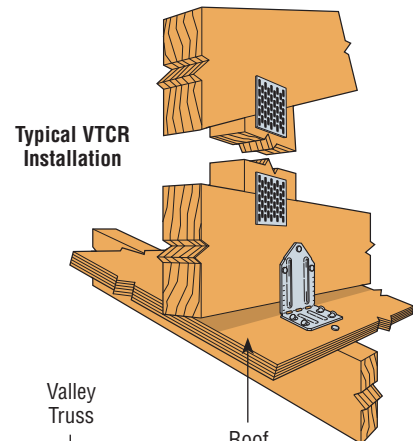

Typical VTCR Roof View
(Install the VTCR at each specified truss top chord location.)

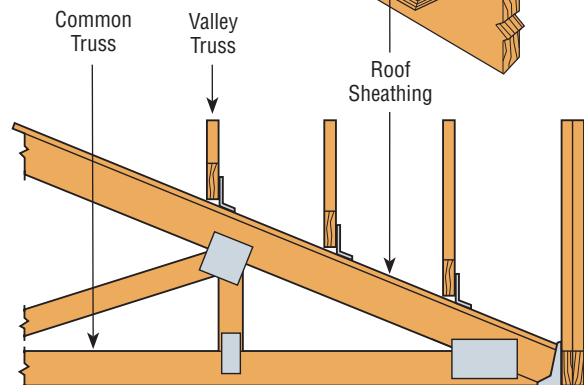

Typical VTCR Side View

GBC Gable Brace Connector



This product is preferable to similar connectors because of a) easier installation, b) higher loads, c) lower installed cost, or a combination of these features.

The GBC provides a proven, tested connection for the anchorage of building stability bracing to the top of the gable end wall. With allowable bracing installation angles between 40° to 60°, the GBC offers greater flexibility in a connector rated for both tension and compression loads.

MATERIAL: 16 gauge

FINISH: Galvanized

INSTALLATION:

- Use all specified fasteners. See General Notes.
- The GBC must be installed in pairs to achieve full load capacity.

CODES: See page 12 for Code Reference Key Chart.

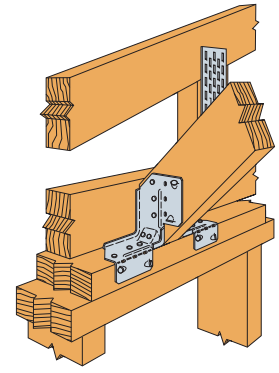
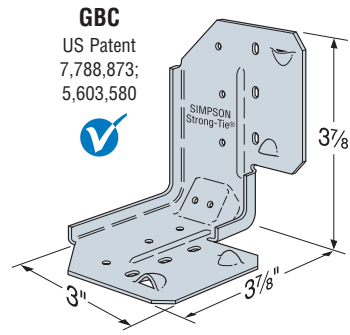

Typical GBC Installation

Model No.	Qty Req'd	Fasteners per Connector		DF/SP Allowable Loads (160) Perpendicular to Endwall (F ₂)				SPF/HF Allowable Loads (160) Perpendicular to Endwall (F ₂)				Code Ref.
				Toward GBC		Away from GBC		Toward Anchors		Away from Anchors		
		Gable Brace	Top Plates	Gable Brace Angle	Gable Brace Angle	Gable Brace Angle	Gable Brace Angle	Gable Brace Angle	Gable Brace Angle	Gable Brace Angle	Gable Brace Angle	
				40°-45°	46°-60°	40°-45°	46°-60°	40°-45°	46°-60°	40°-45°	46°-60°	
GBC	2	5-8dx1½	7-8d	635	570	425	325	535	480	355	275	113, F12

1. For 1½ x 3½ (or larger) LVL gable brace, the allowable load at 40° to 45° is 635 lbs. towards anchors, 515 lbs. away from anchors.
2. Loads have been increased 60% for wind or earthquake loading with no further increase allowed; reduce where other loads govern.
3. Use a minimum 2x4 gable brace. Larger members may be used.
4. **NAILS:** 8d = 0.131" dia. x 2½" long, 8dx1½ = 0.131" dia. x 1½" long. See pages 22-23 for other nail sizes and information.

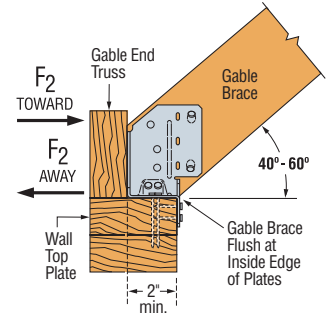

Typical Sloped Installation

GBC INSTALLATION SEQUENCE

Slope	H Dimension
40°	2 15/16"
50°	3 1/16"
60°	3 9/16"

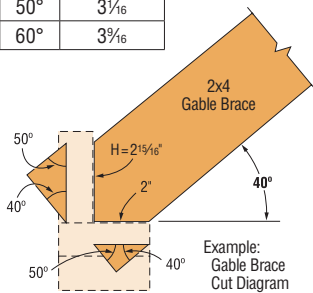

STEP 1

Double angle cut the gable brace to sit flat on the wall double top plate and flush against the gable end truss for 2x4 top plate. The double angle cuts should form a 90° angle on the end of the gable brace.

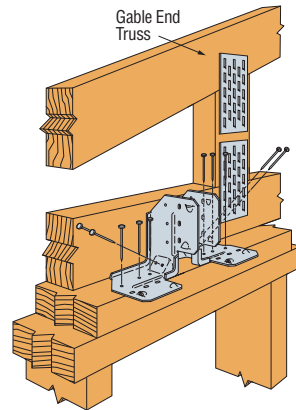

STEP 2

Set each GBC on top of the double top plate so that the bend line slots are flush with the inside edge of the double top plate. Install fasteners into the top of the double top plate.

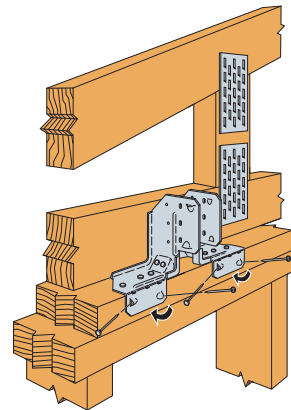

STEP 3

Bend GBC legs (*one time only*) over the inside of the double top plate and install fasteners.

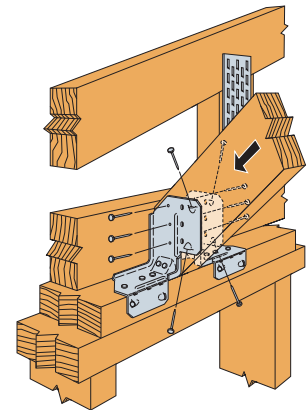

STEP 4

Install fasteners into the gable brace.

NOTE: Attach the other end of the gable brace to blocking at the roof diaphragm as directed by the Designer.

CHC Component Hoist Clip

The CHC component hoist clip provides a tested, load-rated solution for the safe lifting and placement of assembled wood components. The CHC is load-rated with Simpson Strong-Tie® Strong-Drive® SDS Heavy-Duty Connector screws for easy installation and removal, and superior shear and withdrawal strength during lifting.

FEATURES:

- Attaches easily to wood members using Strong-Drive SDS Heavy-Duty Connector screws (*sold separately*)
- May be used alone or in pairs for increased load
- Tested in multiple load directions for versatility

MATERIAL: 12 gauge **FINISH:** Galvanized

INSTALLATION:

- Use all specified fasteners. See General Notes.
- Fasteners require full penetration into the framing members.
- Use one time only.
- Lifting devices should be connected to the CHC with a closed-loop attachment of sufficient strength to carry the allowable load.

CODES: See page 12 for Code Reference Key Chart.

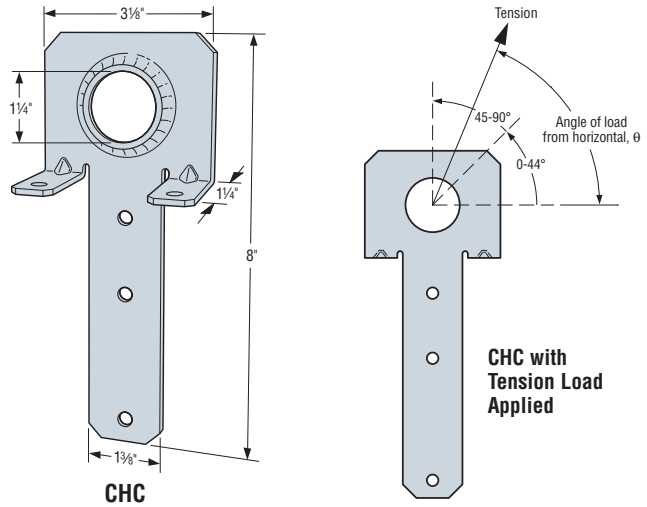

CHC
U.S. Patent 8,720,129

Single Part Allowable Loads

Model No.	Fasteners ⁴		Angle from Horizontal, θ	Allowable Tension DF/SP/SPF/HF (125)	Code Ref.
	Top	Face			
CHC	2-SDS 1/4"x3"	3-SDS 1/4"x3"	0-44	610	170
			45-90	975	

1. Allowable loads are based on the lowest ultimate test load of 3 test specimens, or the average of 6 specimens, divided by 5.
2. No load duration increase allowed.
3. Allowable loads are based on installation over sheathing on stud walls with double 2x top plates and max. 5/8" sheathing.
4. Fasteners require full penetration into the framing members.
5. All lifting devices and spreader bars that are used in conjunction with the CHC shall be of sufficient strength to carry the required load. Spreader bars must also have sufficient rigidity to resist bending of the lifted component.

Allowable Loads for Two Parts

Model No.	Type of Connection	Angle from Horizontal, θ	Line Angle, α	Total Allowable Vertical Load DF/SP/SPF/HF (125)	Code Ref.
CHC	1	30	120	610	170
		45	90	1380	
		60	60	1690	
	2	90	—	1950	

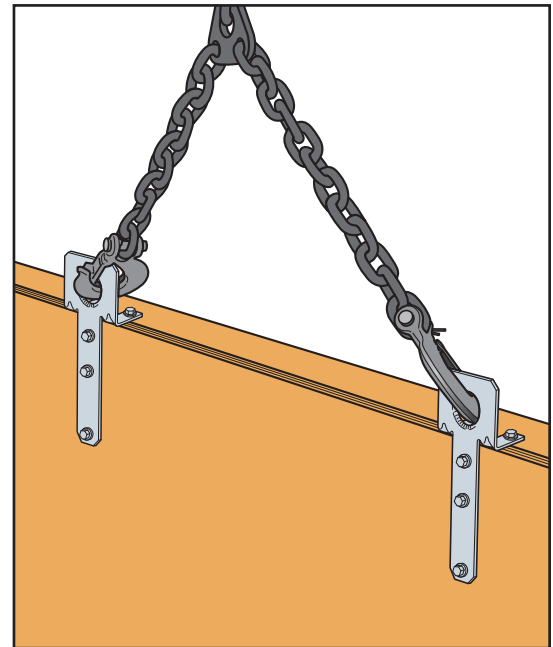

Typical CHC Installation Using Two Parts

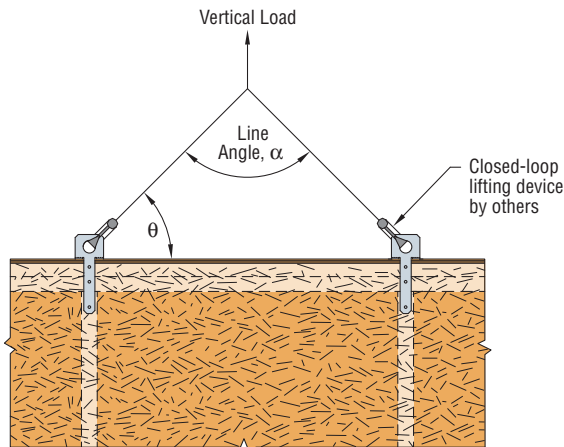

1 Typical CHC Installation with Angular Loading

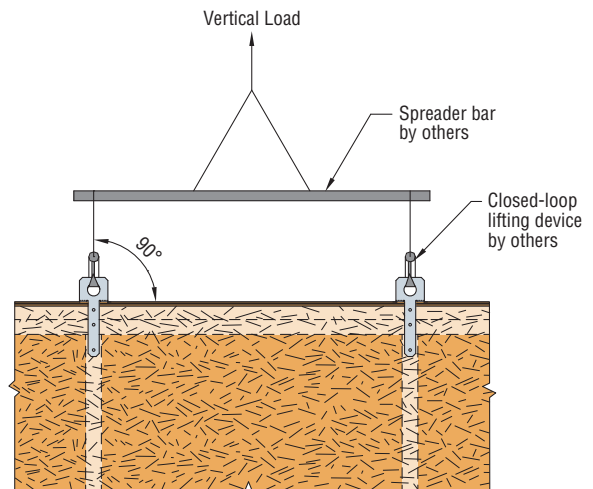

2 Typical CHC Installation with Spreader Bar

TITEN® Screws

Titen screws are 3/16" and 1/4" diameter masonry screws for attaching various components to concrete and masonry. Available in hex and phillips head and both carbon and stainless steel (see the Simpson Strong-Tie® *Anchoring and Fastening Systems for Concrete and Masonry* catalog for information on stainless steel versions). Use with appropriately sized Titen drill bits included with each box.

CODES: FL 2355.1

WARNING: Industry studies show that hardened fasteners can experience performance problems in wet or corrosive environments. Accordingly, use this product in dry and noncorrosive environments only or provide a moisture barrier.

Titen Screw Anchors for Concrete

Titen Diameter (in.)	Drill Bit Diameter (in.)	Embed. Depth (in.)	Critical Spacing (in.)	Critical Edge Dist. (in.)	Allowable Loads				Code Ref.
					Concrete		CMU		
					Tension	Shear	Tension	Shear	
3/16	5/32	1	2 1/4	1 1/8	125	255	110	205	F35
3/16	5/32	1 1/2	2 1/4	1 1/8	305	415	—	—	
1/4	3/16	1	3	1 1/2	145	225	150	250	
1/4	3/16	1 1/2	3	1 1/2	365	400	—	—	

1. Allowable loads may not be increased for short term loading due to wind or seismic forces.
2. Concrete shall have a minimum $f'_c = 2000$ psi. CMU is based on installation into face shell of hollow and grout-filled CMU.
3. The attached member or element may govern the allowable load. The designer shall verify allowable load.
4. Refer to the Simpson Strong-Tie® *Anchoring and Fastening Systems for Concrete and Masonry* catalog (form C-SAS) for complete information on the Titen screws.



Titen Hex Head

WM/WMI/WMU Hangers

See page 174 for sizes, fasteners and load information.

WMs are designed for use on standard 8" grouted masonry block wall construction.

MATERIAL: See table on page 174; WM, WMI, WMU—12 ga. top flange and stirrup

FINISH: Simpson Strong-Tie® gray paint; hot-dip galvanized available; specify HDG.

INSTALLATION:

- Use all specified fasteners.
- WM—two 16d duplex nails must be installed into the top flange and embedded into the grouted wall. Verify that the grouted wall can take the required fasteners specified in the table.
- **MID-WALL INSTALLATION:**
Installed between blocks with duplex nails cast into grout with a minimum of one grouted course above and below the top flange and one #5 vertical rebar minimum 24" long in each adjacent cell.
- **TOP OF WALL INSTALLATION:**
Install on top of wall to a grouted beam with masonry screws.
- Refer to technical bulletin T-SLOPEJST for information regarding load reductions on selected hangers which can be used without modification to support joists which have shallow slopes (3/4:12).

OPTIONS:

- WM/WMI may be skewed and/or sloped to 45° maximum with no reduction. WM/WMI top flange may be offset left or right for placement at the end of a header. The allowable load is 0.50 of the table roof load.
- See Hanger Options pages 233-243 for additional information.
- WMU may not be modified.

CODES: See page 12 for Code Reference Key Chart.

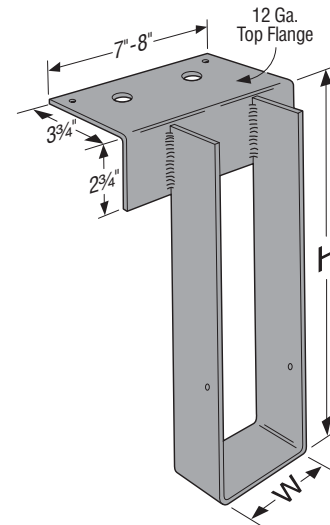

WM

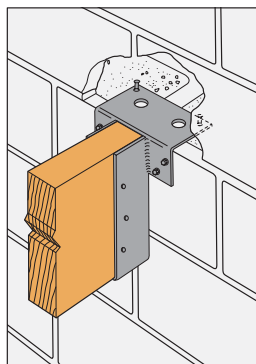

WMU Mid-Wall Installation

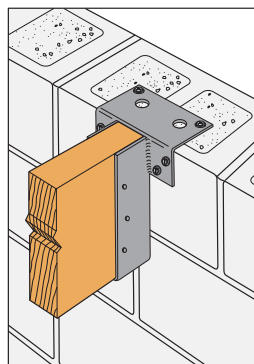

WMU Top-of-Wall Installation

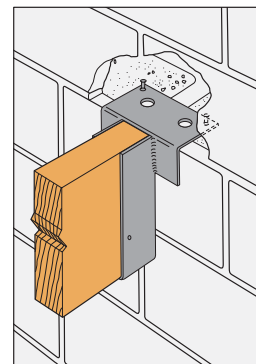

WM Mid-Wall Installation

WM/WMI/WMU Hangers

Joist Size	Model No.	Dimensions		Fasteners				Masonry Allowable Loads						Code Ref.
		W	H	Top Fasteners Mid-Wall Installation	Top Fasteners Top-Of-Wall Installation	Face	Joist	Mid-Wall Installation			Top-of-Wall Installation			
								Uplift	Download (100/115)	Download (125)	Uplift	Download (100/115)	Download (125)	
STANDARD LUMBER SIZES - UPLIFT														
Specify	WMU	1½ to 7½	9 to 28	2-16d Duplex	2-¼x1¼ Titen	4-¼x1¼ Titen	6-10dx1½	625	4175	4175	545	3380	3380	170
STANDARD LUMBER SIZES														
2x6	WM26	1½	5%	2-16d Duplex	2-¼x1 ¾ Titen	—	2-10dx1½	—	4175	4175	—	3380	3380	I21, L16
2x8	WM28	1½	7%	2-16d Duplex	2-¼x1 ¾ Titen	—	2-10dx1½	—	4175	4175	—	3380	3380	
2x10	WM210	1½	9%	2-16d Duplex	2-¼x1 ¾ Titen	—	2-10dx1½	—	4175	4175	—	3380	3380	
2x12	WM12	1½	11	2-16d Duplex	2-¼x1 ¾ Titen	—	2-10dx1½	—	4175	4175	—	3380	3380	
2x14	WM12	1½	13	2-16d Duplex	2-¼x1 ¾ Titen	—	2-10dx1½	—	4175	4175	—	3380	3380	
2x16	WM12	1½	15	2-16d Duplex	2-¼x1 ¾ Titen	—	2-10dx1½	—	4175	4175	—	3380	3380	
2x6 double	WM26-2	3½	5%	2-16d Duplex	2-¼x1 ¾ Titen	—	2-10dx1½	—	4175	4175	—	3380	3380	
2x8 double	WM28-2	3½	7%	2-16d Duplex	2-¼x1 ¾ Titen	—	2-10dx1½	—	4175	4175	—	3380	3380	
2x10 double	WM210-2	3½	9%	2-16d Duplex	2-¼x1 ¾ Titen	—	2-10dx1½	—	4175	4175	—	3380	3380	
2x12 double	WM212-2	3½	11	2-16d Duplex	2-¼x1 ¾ Titen	—	2-10dx1½	—	4175	4175	—	3380	3380	
3x6	WM36	2½	5%	2-16d Duplex	2-¼x1 ¾ Titen	—	2-10dx1½	—	4175	4175	—	3380	3380	
3x8	WM38	2½	7%	2-16d Duplex	2-¼x1 ¾ Titen	—	2-10dx1½	—	4175	4175	—	3380	3380	
3x10	WM310	2½	9%	2-16d Duplex	2-¼x1 ¾ Titen	—	2-10dx1½	—	4175	4175	—	3380	3380	
3x12	WM312	2½	11	2-16d Duplex	2-¼x1 ¾ Titen	—	2-10dx1½	—	4175	4175	—	3380	3380	
3x14	WM314	2½	13	2-16d Duplex	2-¼x1 ¾ Titen	—	2-10dx1½	—	4175	4175	—	3380	3380	
3x16	WM316	2½	15	2-16d Duplex	2-¼x1 ¾ Titen	—	2-10dx1½	—	4175	4175	—	3380	3380	
4x6	WM46	3½	5%	2-16d Duplex	2-¼x1 ¾ Titen	—	2-10dx1½	—	4175	4175	—	3380	3380	
4x8	WM48	3½	7%	2-16d Duplex	2-¼x1 ¾ Titen	—	2-10dx1½	—	4175	4175	—	3380	3380	
4x10	WM410	3½	9%	2-16d Duplex	2-¼x1 ¾ Titen	—	2-10dx1½	—	4175	4175	—	3380	3380	
4x12	WM412	3½	11	2-16d Duplex	2-¼x1 ¾ Titen	—	2-10dx1½	—	4175	4175	—	3380	3380	
4x14	WM414	3½	13	2-16d Duplex	2-¼x1 ¾ Titen	—	2-10dx1½	—	4175	4175	—	3380	3380	
4x16	WM416	3½	15	2-16d Duplex	2-¼x1 ¾ Titen	—	2-10dx1½	—	4175	4175	—	3380	3380	
6x6	WM66	5½	5%	2-16d Duplex	2-¼x1 ¾ Titen	—	2-10dx1½	—	4175	4175	—	3380	3380	
6x8	WM68	5½	7%	2-16d Duplex	2-¼x1 ¾ Titen	—	2-10dx1½	—	4175	4175	—	3380	3380	
6x10	WM610	5½	9%	2-16d Duplex	2-¼x1 ¾ Titen	—	2-10dx1½	—	4175	4175	—	3380	3380	
ENGINEERED LUMBER SIZES														
1½x9¼	WM29.25	1½	9¼	2-16d Duplex	2-¼x1 ¾ Titen	—	2-10dx1½	—	4175	4175	—	3380	3380	I21, L16
1½x9½	WM29.5	1½	9½	2-16d Duplex	2-¼x1 ¾ Titen	—	2-10dx1½	—	4175	4175	—	3380	3380	
1½x11¼	WM211.25	1½	11¼	2-16d Duplex	2-¼x1 ¾ Titen	—	2-10dx1½	—	4175	4175	—	3380	3380	
1½x11½	WM211.88	1½	11½	2-16d Duplex	2-¼x1 ¾ Titen	—	2-10dx1½	—	4175	4175	—	3380	3380	
1¾x9½	WM9	1¾	9½	2-16d Duplex	2-¼x1 ¾ Titen	—	2-10dx1½	—	4175	4175	—	3380	3380	
1¾x11½	WM11	1¾	11½	2-16d Duplex	2-¼x1 ¾ Titen	—	2-10dx1½	—	4175	4175	—	3380	3380	
1¾x14	WM14	1¾	14	2-16d Duplex	2-¼x1 ¾ Titen	—	2-10dx1½	—	4175	4175	—	3380	3380	
1¾x16	WM16	1¾	16	2-16d Duplex	2-¼x1 ¾ Titen	—	2-10dx1½	—	4175	4175	—	3380	3380	
2¾x11½	WM3511.88	2¾	11½	2-16d Duplex	2-¼x1 ¾ Titen	—	2-10dx1½	—	4175	4175	—	3380	3380	
2¾x14	WM3514	2¾	14	2-16d Duplex	2-¼x1 ¾ Titen	—	2-10dx1½	—	4175	4175	—	3380	3380	
2¾x16	WM3516	2¾	16	2-16d Duplex	2-¼x1 ¾ Titen	—	2-10dx1½	—	4175	4175	—	3380	3380	
2¾x18	WM3518	2¾	18	2-16d Duplex	2-¼x1 ¾ Titen	—	2-10dx1½	—	4175	4175	—	3380	3380	
2¾x20	WM3520	2¾	20	2-16d Duplex	2-¼x1 ¾ Titen	—	2-10dx1½	—	4175	4175	—	3380	3380	
2½x14	WMI314	2½	14	2-16d Duplex	2-¼x1 ¾ Titen	—	2-10dx1½	—	4175	4175	—	3380	3380	
2½x16	WMI316	2½	16	2-16d Duplex	2-¼x1 ¾ Titen	—	2-10dx1½	—	4175	4175	—	3380	3380	
2½x18	WMI318	2½	18	2-16d Duplex	2-¼x1 ¾ Titen	—	2-10dx1½	—	4175	4175	—	3380	3380	
2½x20	WMI320	2½	20	2-16d Duplex	2-¼x1 ¾ Titen	—	2-10dx1½	—	4175	4175	—	3380	3380	
3x9¼	WM29.25-2	3	9¼	2-16d Duplex	2-¼x1 ¾ Titen	—	2-10dx1½	—	4175	4175	—	3380	3380	
3x9½	WM29.5-2	3	9½	2-16d Duplex	2-¼x1 ¾ Titen	—	2-10dx1½	—	4175	4175	—	3380	3380	
3x11¼	WM211.25-2	3	11¼	2-16d Duplex	2-¼x1 ¾ Titen	—	2-10dx1½	—	4175	4175	—	3380	3380	
3x11½	WM211.88-2	3	11½	2-16d Duplex	2-¼x1 ¾ Titen	—	2-10dx1½	—	4175	4175	—	3380	3380	
3½x9½	WM3.56/9.5	3½	9½	2-16d Duplex	2-¼x1 ¾ Titen	—	2-10dx1½	—	4175	4175	—	3380	3380	
3½x11½	WM3.56/11.88	3½	11½	2-16d Duplex	2-¼x1 ¾ Titen	—	2-10dx1½	—	4175	4175	—	3380	3380	
3½x12	WMI412	3½	12	2-16d Duplex	2-¼x1 ¾ Titen	—	2-10dx1½	—	4175	4175	—	3380	3380	
3½x14	WMI414	3½	14	2-16d Duplex	2-¼x1 ¾ Titen	—	2-10dx1½	—	4175	4175	—	3380	3380	
3½x16	WMI416	3½	16	2-16d Duplex	2-¼x1 ¾ Titen	—	2-10dx1½	—	4175	4175	—	3380	3380	
3½x18	WMI418	3½	18	2-16d Duplex	2-¼x1 ¾ Titen	—	2-10dx1½	—	4175	4175	—	3380	3380	
3½x20	WMI420	3½	20	2-16d Duplex	2-¼x1 ¾ Titen	—	2-10dx1½	—	4175	4175	—	3380	3380	
4½x11½	WM3511.88-2	4½	11½	2-16d Duplex	2-¼x1 ¾ Titen	—	2-10dx1½	—	4175	4175	—	3380	3380	
4½x14	WM3514-2	4½	14	2-16d Duplex	2-¼x1 ¾ Titen	—	2-10dx1½	—	4175	4175	—	3380	3380	
4½x16	WM3516-2	4½	16	2-16d Duplex	2-¼x1 ¾ Titen	—	2-10dx1½	—	4175	4175	—	3380	3380	
4½x18	WM3518-2	4½	18	2-16d Duplex	2-¼x1 ¾ Titen	—	2-10dx1½	—	4175	4175	—	3380	3380	
4½x20	WM3520-2	4½	20	2-16d Duplex	2-¼x1 ¾ Titen	—	2-10dx1½	—	4175	4175	—	3380	3380	
5½x9½	WM5.50/9.5	5½	9½	2-16d Duplex	2-¼x1 ¾ Titen	—	2-10dx1½	—	4175	4175	—	3380	3380	
5½x11½	WM5.50/11.88	5½	11½	2-16d Duplex	2-¼x1 ¾ Titen	—	2-10dx1½	—	4175	4175	—	3380	3380	
7x9½	WMI49.5-2	7	9½	2-16d Duplex	2-¼x1 ¾ Titen	—	2-10dx1½	—	4175	4175	—	3380	3380	
7x11¼	WM411.25-2	7	11¼	2-16d Duplex	2-¼x1 ¾ Titen	—	2-10dx1½	—	4175	4175	—	3380	3380	
7x11½	WM411.88-2	7	11½	2-16d Duplex	2-¼x1 ¾ Titen	—	2-10dx1½	—	4175	4175	—	3380	3380	
7x14	WM414-2	7	14	2-16d Duplex	2-¼x1 ¾ Titen	—	2-10dx1½	—	4175	4175	—	3380	3380	
7x16	WM416-2	7	16	2-16d Duplex	2-¼x1 ¾ Titen	—	2-10dx1½	—	4175	4175	—	3380	3380	
7x18	WM418-2	7	18	2-16d Duplex	2-¼x1 ¾ Titen	—	2-10dx1½	—	4175	4175	—	3380	3380	
7x20	WM420-2	7	20	2-16d Duplex	2-¼x1 ¾ Titen	—	2-10dx1½	—	4175	4175	—	3380	3380	

1. Uplift loads have been increased for wind or earthquake loading with no further increase allowed. Reduce where other loads govern.
 2. See figures for Top-of-Wall and Mid-Wall installation. Minimum $f_m = 1500$ psi.
 3. Products shall be installed such that Titen® screws are not exposed to weather.

4. For hanger heights that exceed the joist height, the allowable download is 0.50 of the table load.
 5. **NAILS:** 16d Duplex = 0.162" dia. x 3½" long, 10dx1½ = 0.148" dia. x 1½" long. See pages 22-23 for other nail sizes and information.

HU/HUC/HSUR/L Hangers

HU and HUC products are heavy duty face mount joist hangers made from 14 gauge galvanized steel.

- The HUC is a concealed flange version of the HU. Concealed flange hangers have the header flanges turned in.
- HU is available with header flanges concealed, provided the W dimension is 2 5/16" or greater, at 100% of the table load. Specify HUC.
- HU is available with one header flange concealed when the W dimension is less than 2 5/16" at 100% of the table load.
- For allowable loads on HU products not listed in the table, request technical bulletin T-HUHUCTTN.

MATERIAL: 14 gauge

FINISH: Galvanized, ZMAX® and stainless steel available

INSTALLATION: • These hangers are attached to grouted CMU walls using 1/4"x2 3/4" hex head Simpson Strong-Tie® Titen® screws or for concrete walls using 1/4"x1 1/4" hex head Titen screws. Titen screws are not provided.

- Drill the 3/16" diameter hole to the specified embedment depth plus 1/2".
- Alternatively, drill the 3/16" diameter hole to the specified embedment depth and blow it clean using compressed air.
- Caution: Oversized holes in the base material will reduce or eliminate the mechanical interlock of the threads with the base material and will reduce the anchor's load capacity.
- The hangers should be installed such that a minimum end and edge distance of 1 1/2" is maintained.
- Provide moisture barrier between beam and wall per jurisdictional requirements.

CODES: See page 12 for Code Reference Key Chart.

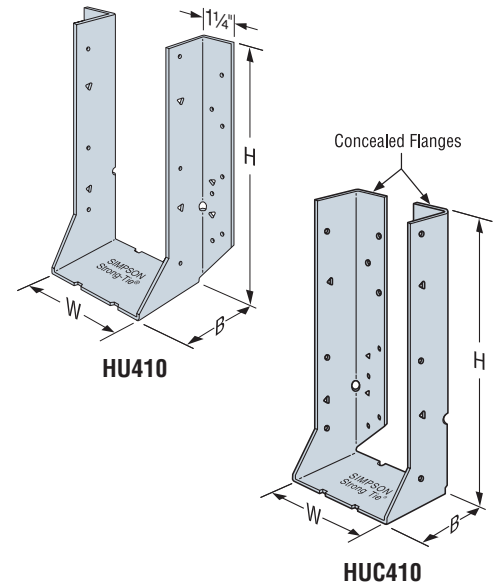

These products are available with additional corrosion protection. Additional products on this page may also be available with this option, check with Simpson Strong-Tie for details.

Model No.	Dimensions			Fasteners			Allowable Loads (DF/SP)		Code Ref.
	W	H	B	CMU	Concrete	Joist	Uplift (160)	Down (100/115/125)	
HU26	1 5/16	3 1/16	2 1/4	4-1/4x2 3/4 Titen	4-1/4x1 1/4 Titen	2-10dx1 1/2	290	1545	170
HU28 ³	1 5/16	5 1/4	2 1/4	6-1/4x2 3/4 Titen	6-1/4x1 1/4 Titen	4-10dx1 1/2	575	2400	
HU210	1 5/16	7 1/8	2 1/4	8-1/4x2 3/4 Titen	8-1/4x1 1/4 Titen	4-10dx1 1/2	575	2400	
HU46	3 3/16	5 3/16	2 1/2	12-1/4x2 3/4 Titen	12-1/4x1 1/4 Titen	6-10d	1085	3950	
HU26-2	3 3/8	5 3/8	2 1/2	12-1/4x2 3/4 Titen	12-1/4x1 1/4 Titen	6-10d	1085	3950	
HU48	3 3/16	6 3/16	2 1/2	14-1/4x2 3/4 Titen	14-1/4x1 1/4 Titen	6-10d	1085	4350	
HU28-2	3 3/8	7	2 1/2	14-1/4x2 3/4 Titen	14-1/4x1 1/4 Titen	6-10d	1085	4350	
HU410	3 3/16	8 3/8	2 1/2	18-1/4x2 3/4 Titen	18-1/4x1 1/4 Titen	10-10d	1810	5085	
HU210-2	3 3/8	8 3/16	2 1/2	18-1/4x2 3/4 Titen	18-1/4x1 1/4 Titen	10-10d	1810	5085	
HSUR/L26-2	3 3/8	4 13/16	2 1/16	12-1/4x2 3/4 Titen	12-1/4x1 1/4 Titen	4-16dx2 1/2	815	2625 ⁵	

1. Uplift loads have been increased for wind or earthquake loading with no further increase is allowed. Reduce where other loads govern.
2. Minimum concrete strength f'c shall be 2500 psi. CMU shall have a minimum grout strength of 2500 psi with standard ASTM C90 units and type N or S mortar.
3. The HU28 can be ordered skewed 45° and achieve the same loads.
4. See page 173 for Titen screw information. Use stainless-steel Titen® screws and products in exposed applications. Tabulated loads apply to stainless-steel applications.
5. Noted loads for the HSUR/L shall be 0.8 the table loads for concrete applications.
6. Table allowable loads were determined using tested lowest ultimate/3 or fastener calculation values.
7. **NAILS:** 16dx2 1/2 = 0.162" dia. x 2 1/2" long, 10d = 0.148" dia. x 3" long, 10dx1 1/2 = 0.148" dia. x 1 1/2" long. See pages 22-23 for other nail sizes and information.

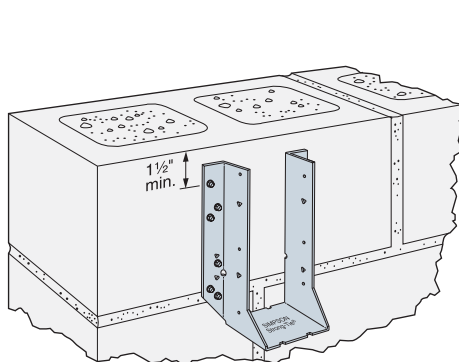

HU410 Installed on Masonry Block Sidewall

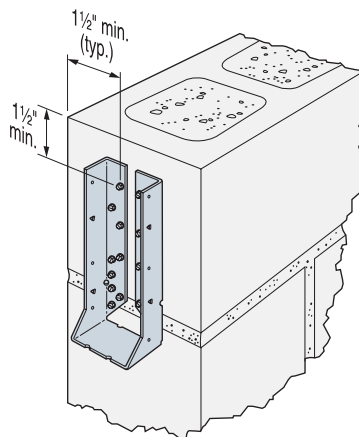

HUC410 Installed on Masonry Block End Wall

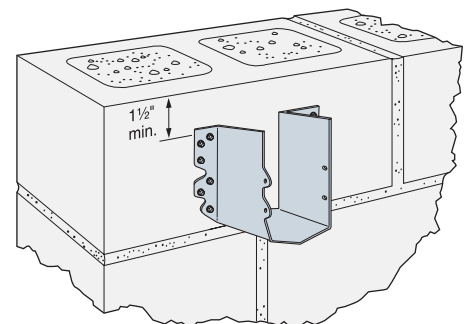

HSUR/L26-2 Installed on Masonry Block Sidewall

LGUM/HGUM High Capacity Beam/Girder Hangers for Concrete/Masonry

High-capacity beam or girder hangers for concrete or masonry applications. Installation is made easier using Simpson Strong-Tie® Strong-Drive® SDS Heavy-Duty Connector screws (provided) into the wood member and Titen HD® anchors (provided) into the masonry.

MATERIAL: See table **FINISH:** Galvanized

INSTALLATION: • Use all specified fasteners (included).

- Attach hanger to a concrete or grouted CMU wall using Titen HD anchors. Note the following:
 - Drill holes using drill bits equal in diameter to the specified Titen HD anchor.
 - Holes shall be drilled 1/2" deeper than the specified Titen HD length (i.e. 4 1/2" for a 4" long Titen HD anchor)
 - Caution: Oversized holes in the base material will reduce or eliminate the mechanical interlock of the threads with the base material and will reduce the anchor's load capacity.
- Titen HD is not recommended for exposed exterior applications.
- Provide moisture barrier between beam and wall per jurisdictional requirements.

OPTIONS: • For HGUM only—Other seat widths available. Order as "X" version.

- HGUM available with one flange concealed.
 - LGUM/HGUM available in skews up to 45°.
- See Hanger Options, pages 233-243.

CODES: See page 12 for Code Reference Key Chart.

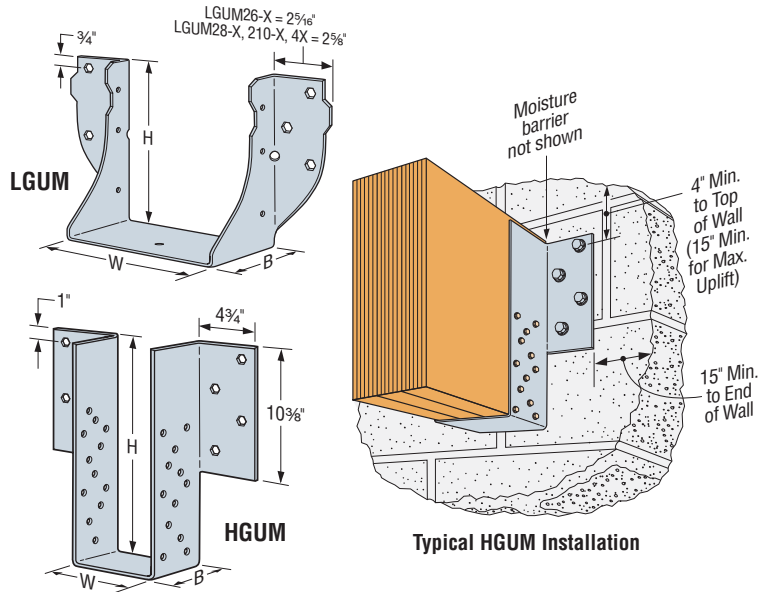

Model No.	Ga	Dimensions			Fasteners		Allowable Loads				Code Ref.
		W	H	B	CMU/Concrete	Joist	Uplift (160)		Download (DF, SP, LVL, PSL, LSL)		
					Titen HD Anchors	SDS Screws	4" Min. to Top of Wall	15" Min. to Top of Wall	CMU	Concrete	
DOUBLE 2x SIZES											F27
LGUM26-2-SDS	12	3 5/16	5 7/16	4	4 - 3/8" x 4"	4 - 1/4" x 2 1/2"	1430	1430	5595		
LGUM28-2-SDS	12	3 5/16	7 3/16	4	6 - 3/8" x 4"	6 - 1/4" x 2 1/2"	2435	2435	8250		
LGUM210-2-SDS	12	3 5/16	9 3/16	4	8 - 3/8" x 4"	8 - 1/4" x 2 1/2"	3575	3575	9575		
TRIPLE 2x SIZES											
LGUM26-3-SDS	12	4 1 5/16	5 1/2	4	4 - 3/8" x 4"	4 - 1/4" x 2 1/2"	1430	1430	5610		
LGUM28-3-SDS	12	4 1 5/16	7 1/4	4	6 - 3/8" x 4"	6 - 1/4" x 2 1/2"	2435	2435	8290		
LGUM210-3-SDS	12	4 1 5/16	9 1/4	4	8 - 3/8" x 4"	8 - 1/4" x 2 1/2"	3575	3575	9715		
QUADRUPLE 2x SIZES											
LGUM26-4-SDS	12	6 9/16	5 7/16	4	4 - 3/8" x 4"	4 - 1/4" x 2 1/2"	1430	1430	5625		
LGUM28-4-SDS	12	6 9/16	7 3/16	4	6 - 3/8" x 4"	6 - 1/4" x 2 1/2"	2435	2435	8335		
LGUM210-4-SDS	12	6 9/16	9 3/16	4	8 - 3/8" x 4"	8 - 1/4" x 2 1/2"	3575	3575	9860		
4x SIZES											
LGUM46-SDS	12	3 3/8	4 7/8	4	4 - 3/8" x 4"	4 - 1/4" x 2 1/2"	1430	1430	5600		
LGUM48-SDS	12	3 3/8	6 1/8	4	6 - 3/8" x 4"	6 - 1/4" x 2 1/2"	2435	2435	8260		
LGUM410-SDS	12	3 3/8	8 1/8	4	8 - 3/8" x 4"	8 - 1/4" x 2 1/2"	3575	3575	9620		
ENGINEERED WOOD & STRUCTURAL COMPOSITE LUMBER SIZES (Heavy Duty)											
HGUM5.25-SDS	7	5 1/4	11 to 30	5 1/4	8 - 3/8" x 5"	24 - 1/4" x 2 1/2"	4230 ²	6180 ²	14965	16015	
HGUM5.50-SDS	7	5 1/2		5 1/4	8 - 3/8" x 5"	24 - 1/4" x 2 1/2"	4230 ²	6180 ²	14940	16015	
HGUM7.00-SDS	7	7		5 1/4	8 - 3/8" x 5"	24 - 1/4" x 2 1/2"	4230 ²	6180 ²	14770	16015	
HGUM7.25-SDS	7	7 1/4		5 1/4	8 - 3/8" x 5"	24 - 1/4" x 2 1/2"	4230 ²	6180 ²	14740	16015	
HGUM9.00-SDS	7	9		5 1/4	8 - 3/8" x 5"	24 - 1/4" x 2 1/2"	4230 ²	6180 ²	14545	16015	

1. Uplift loads have been increased for wind or earthquake loading with no further increase is allowed.
2. HGUM uplift loads for concrete applications are 5840 lbs. with a 4" min. distance to top of wall and 6960 lbs. with a 15" min. distance to top of wall.
3. Minimum $f_m = 1500$ psi and $f'_c = 2500$ psi.
4. LGUM must be installed on minimum 6" thick wall and HGUM on minimum 8" thick wall. (Nominal values for CMU)
5. Titen HD anchors may be installed into the head or bed joints.
6. Simpson Strong-Tie Strong-Drive SDS Heavy-Duty Connector screws are permitted to be installed through metal truss plates as approved by the Truss Designer, provided the requirements of ANSI/TPI 1-2007 Sections 7.5.3.4 and 8.9.2 are met (pre-drilling required through the plate using a maximum of 5/32" bit).

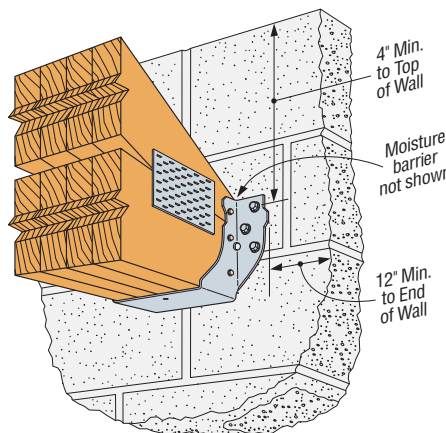

Typical LGUM Installation

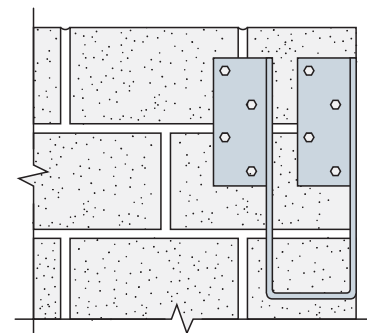

HGUM with right flange concealed
(See page 243 for reduction factors)

MBHU *Masonry Beam Hangers*

The new MBHU beam hanger provides a face-mounted solution for connecting beams to masonry or concrete walls. A non-welded, one-piece connector, the MBHU is suitable for solid sawn and engineered wood beams as well as trusses. Installation is simplified because the Titen HD® heavy-duty screw anchor and Strong-Drive® SDS Heavy-Duty Connector screws are included with the hanger. Since the Titen HD anchor is installed after the wall is built, locating the anchor in the right spot is easier than with cast-in-place bolts.

MATERIAL: 10 gauge

FINISH: Galvanized

INSTALLATION: • Use all specified fasteners (included).

- Attach hanger to a concrete or grouted CMU wall using Titen HD anchors. Note the following:
 - Drill holes using drill bits equal in diameter to the specified Titen HD anchor.
 - Holes shall be drilled ½" deeper than the specified Titen HD length (i.e. 5½" for a 5" long Titen HD anchor)
 - Caution: Oversized holes in the base material will reduce or eliminate the mechanical interlock of the threads with the base material and will reduce the anchor's load capacity.
- Titen HD is not recommended for exposed exterior applications.
- Provide moisture barrier between beam and wall per jurisdictional requirements.

CODES: See page 12 for Code Reference Key Chart.

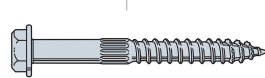
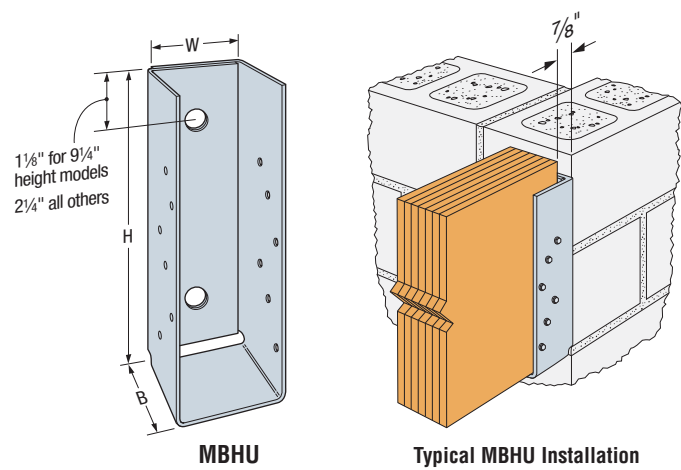

¼"x2½" Strong-Drive® SDS HEAVY-DUTY CONNECTOR Screw

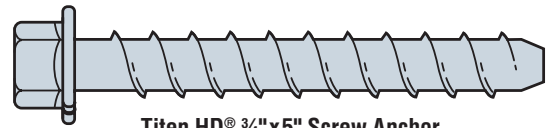

Titen HD® ¾"x5" Screw Anchor

Model No.	Dimensions	
	Width (W) (in.)	Height (H) (in.)
MBHU3.56/9.25KT	3⅞	9¼
MBHU3.56/11.25KT	3⅞	11¼
MBHU3.56/11.88KT	3⅞	11⅞
MBHU3.56/14KT	3⅞	14
MBHU3.56/16KT	3⅞	16
MBHU3.56/18KT	3⅞	18
MBHU5.50/9.25KT	5½	9¼
MBHU5.50/11.25KT	5½	11¼
MBHU5.50/11.88KT	5½	11⅞
MBHU5.50/14KT	5½	14
MBHU5.50/16KT	5½	16
MBHU5.50/18KT	5½	18

Series Model No.	Ga	Dimensions (in.)			Fasteners		Allowable Loads End of Wall / Outside Corner DF/SP				Allowable Loads Away from Edge DF/SP		Code Ref.
		W	H	B	CMU/Concrete	Joist	CMU		Concrete		CMU/Concrete		
							Uplift ³	Download	Uplift	Download	Uplift	Download	
MBHU3.56	10	3⅞	9¼ to <14	3⅞	2-¾"x5"	12-¼"x2½"	(160)	(100/115/125)	(160)	(100/115/125)	(160)	(100/115/125)	F24
			14 to 18				1720	2440	2715	4190	2210	4005	
MBHU5.50	10	5½	9¼ to <14	3⅞	2-¾"x5"	12-¼"x2½"	1720	2440	2715	4190	2210	4005	
			14 to 18				2175	3260	3485	6970	3345	6065	

1. Uplift loads have been increased for wind or earthquake loading with no further increase allowed; reduce where other loads govern.
2. Minimum CMU compressive strength f_m shall be 1500 psi and concrete compressive strength f_c shall be 2500 psi.
3. Structural composite lumber (SCL) shall have a minimum specific gravity of 0.5.
4. Allowable loads only apply to installation on 8" nominal grouted CMU walls, with minimum one horizontal #5 rebar located in the top course.
5. Products shall be installed such that the Titen HD® anchors are not exposed to the weather.
6. Allowable loads are based upon the tested ultimate load with a safety factor of 3.

1. Each MBHU hanger includes (2) ¾"x5" Titen HD® anchors and (12) ¼"x2½" Strong-Drive® SDS Heavy-Duty Connector screws.

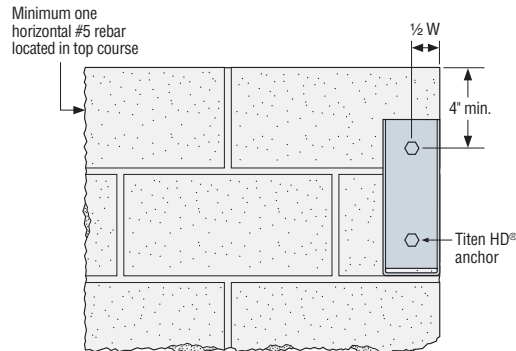

Installation at Outside Corner (Minimum Load)

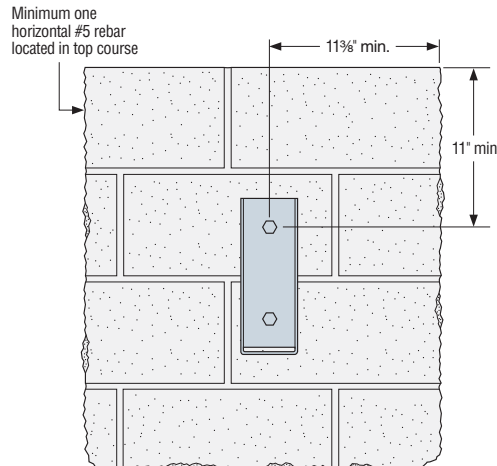

Installation Away from Edge of Wall (Maximum Load)

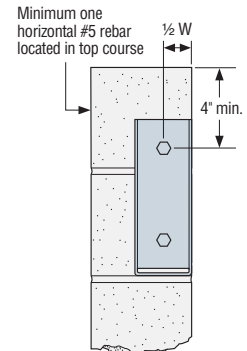

Installation on End of Wall (Minimum Load)

MBHA Masonry Hangers

The MBHA is a single piece, non-welded connector available for solid sawn, truss and engineered wood products.

MATERIAL: 10 gauge **FINISH:** Galvanized

INSTALLATION: • Use all specified fasteners. See General Notes.

OPTIONS: • Seat can be skewed at 45° only. The maximum allowable download is 3495 lbs. and 1585 lbs. uplift for height 7¼". For all other models, use the table listed download and uplift of 2390 lbs. Order MBHAR for skew right and MBHAL for skew left.

CODES: See page 12 for Code Reference Key Chart.

Model No.	C	Dimensions	
		W	H
MBHA3.12/9.25	1⅞	3⅜	9¼
MBHA3.12/11.25	1⅞	3⅜	11¼
MBHA3.56/7.25	1¾	3⅞	7¼
MBHA3.56/9.25	1¾	3⅞	9¼
MBHA3.56/11.25	1¾	3⅞	11¼
MBHA3.56/11.88	1¾	3⅞	11⅞
MBHA3.56/14	1¾	3⅞	14
MBHA3.56/16	1¾	3⅞	16
MBHA3.56/18	1¾	3⅞	18
MBHA5.50/7.25	2¾	5½	7¼
MBHA5.50/9.25	2¾	5½	9¼
MBHA5.50/11.25	2¾	5½	11¼
MBHA5.50/11.88	2¾	5½	11⅞
MBHA5.50/14	2¾	5½	14
MBHA5.50/16	2¾	5½	16
MBHA5.50/18	2¾	5½	18

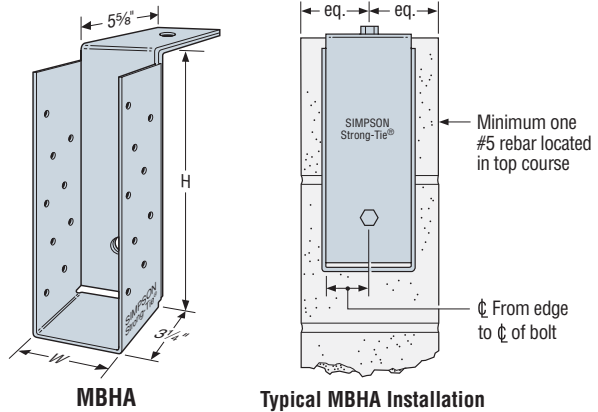

Model No.	Fasteners ¹			Solid Concrete Allowable Loads DF/SP		Grouted CMU Allowable Loads DF/SP		Code Ref.
	Header		Joist	Uplift ⁷ (160)	Maximum Down Load	Uplift ⁷ (160)	Maximum Down Load	
	Top	Face						
MBHA	1-ATR¾"	1-ATR¾"	18-10d	3775	6050	3475	5330	I20, L16, F19
MBHA models with H = 7¼"	1-ATR¾"	1-ATR¾"	18-10d	1885	4380	1885	4380	

- ATR is all threaded rod.
- Minimum concrete strength f_c shall be 2500 psi. CMU shall have a minimum grout strength of 2500 psi with standard ASTM C90 units and type N or S mortar.
- Uplift loads have been increased 60% for wind or earthquake loading with no further increase allowed; reduce where other loads govern.
- Loads are based on installation using Simpson Strong-Tie® ET Epoxy-Tie® adhesive 6¼" minimum embedment required. All thread rods to be ¾" diameter, grade A307 or better. Refer to the Simpson Strong-Tie® Anchoring and Fastening

- Systems for Concrete and Masonry catalog (form C-SAS).
- MBHA hangers with height of 7¼" require a 3½" minimum embedment of the face bolt using ET Epoxy-Tie adhesive. All thread rods to be ¾" diameter, grade A307 or better.
- Additional anchorage products to be designed by others.
- Uplift loads are for Southern Pine. For Doug Fir use 3515 lbs.
- Table allowable loads were determined using test ultimate/3 or fastener calculation values.
- NAILS:** 10d = 0.148" dia. x 3" long. See pages 22-23 for other nail sizes and information.

Masonry Connectors

H Seismic & Hurricane Ties / **LTA2** Lateral Truss Anchor

The Hurricane Tie series features various configurations of wind and seismic ties for trusses and rafters.

The H10S provides a high capacity connection from truss/rafter to wall. Also suitable for wood-to-wood applications (see page 196).

The HM9 is designed to retrofit roof truss/rafters for block construction. The HM9 hurricane tie provides high uplift and lateral capacity using Simpson Strong-Tie® concrete fasteners.

The presloped 5/12 seat of the H16 provides for a tight fit and reduced deflection. The strap length provides for various truss heights up to a maximum of 13½". Minimum heel height for H16 series is 4".

The new LTA2 is an embedded truss anchor for grouted CMU and concrete walls that develops high loads with shallow embedment. Designed for 2x4 minimum truss chords, the LTA2 resists uplift and lateral loads parallel and perpendicular to the wall with a minimum heel height requirement.

FEATURES:

- Simplified design of the embedded portion allows for easy positioning close to rebar
- Ideal for anchoring trusses running perpendicular or parallel to the wall
- Embedment line stamped on part simplifies installation and helps avoid installation errors

MATERIAL: H Ties—see table; LTA2—18 gauge

FINISH: Galvanized; see Corrosion Information, pages 13-15.

INSTALLATION: • Use all specified fasteners. See General Notes.

H Ties:

- Connectors attached using hex head Simpson Strong-Tie® Titen® screws.
- Attach to grouted concrete block with a minimum one #5 rebar horizontal in the course.
- Hurricane Ties do not replace solid blocking.

LTA2:

- Whether in grouted CMU or concrete, the LTA2 must be embedded to the depth of the embedment line stamped on the part.
- A minimum of one horizontal #5 rebar is required at top of concrete or in the top course of grouted CMU.
- For parallel-to-wall applications, install the LTA2 with flanges facing the center of the wall. Minimum edge distance of 1½" required.

CODES: See page 12 for Code Reference Key Chart.

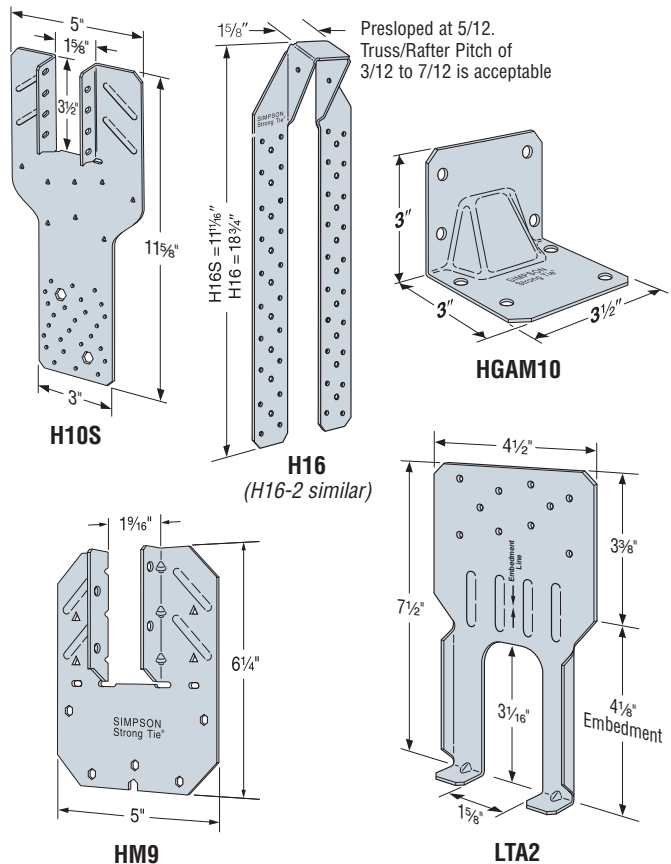

H Seismic & Hurricane Ties / **LTA2** Lateral Truss Anchor

Model No.	Ga	W	L	Fasteners			DF/SP Allowable Loads ^{1,2}			SPF/HF Allowable Loads ^{1,2}			Code Ref.		
				To Rafters/Truss	To CMU	To Concrete	Uplift ⁴		Lateral (160)		Uplift ⁴			Lateral (160)	
							(160)	F ₁	F ₂	(160)	F ₁	F ₂			
HM9KT ³	18	1 ⁹ / ₁₆	6 ³ / ₄	4-SDS 1/4"x1 1/2"	5-1/4x2 1/4 Titen	5-1/4x1 1/4 Titen	595	425	200	595	425	200	F27		
HGAM10KTA ³	14	—	—	4-SDS 1/4"x1 1/2"	4-1/4x2 3/4 Titen	4-1/4x1 1/4 Titen	850	1005	1105 ⁷	610	725	795 ⁷			
H10S	18	1 ⁵ / ₈	11 ⁵ / ₈	8-8dx1 1/2	2-3/8x4 Titen HD	2-3/8x4 Titen HD	1065	—	—	915	—	—	IP1, F25		
LTA2 Perpendicular to Wall Installation	18	—	—	10-10dx1 1/2	Embed	Embed	1210 ⁸	415	875	1015	415	735	F24		
LTA2 Parallel to Wall Installation	18	—	—	10-10dx1 1/2	Embed	Embed	1210 ⁸	950	220	1015	800	220			
H16	18	1 ⁵ / ₈	18 ³ / ₄	2-10dx1 1/2	6-1/4x2 1/4 Titen	6-1/4x1 1/4 Titen	1470	—	—	1265	—	—	F26		
H16S	18	1 ⁵ / ₈	11 ¹ / ₁₆	2-10dx1 1/2	6-1/4x2 1/4 Titen	6-1/4x1 1/4 Titen	1470	—	—	1265	—	—			
H16-2	18	3 ¹ / ₄	18 ³ / ₄	2-10dx1 1/2	6-1/4x2 1/4 Titen	6-1/4x1 1/4 Titen	1470	—	—	1265	—	—			
H16-2S	18	3 ¹ / ₄	11 ¹ / ₁₆	2-10dx1 1/2	6-1/4x2 1/4 Titen	6-1/4x1 1/4 Titen	1470	—	—	1265	—	—			

1. Loads have been increased for wind or earthquake loading with no further increase allowed. Reduce where other loads govern.
2. Allowable loads are for one anchor. A minimum rafter thickness of 2 1/2" must be used when framing anchors are installed on each side of the joist and on the same side of the plate.
3. The HM9KT and HGAM10KTA are kits with (20) HM9 and (10) HGAM10 connectors packaged with Simpson Strong-Tie® Strong-Drive® SDS Heavy-Duty Connector screws and 2 1/4" and 2 3/4" Titen® screws, respectively. (1 1/4" Titen screws for concrete installations sold separately.)
4. See page 173 for Titen screw information.
5. Table allowable loads were determined using test ultimate/3 or fastener calculation values.
6. Products shall be installed such that the Titen screws and Titen HD® anchors are not exposed to the weather.
7. HGAM10 F₂ loads are for forces into the connector. See illustration 2 for loads away from the connector.
8. LTA2 allowable uplift on SP is 1425 lbs. for perpendicular to wall installation and 1390 lbs. for parallel to wall installation.
9. **NAILS:** 10dx1 1/2 = 0.148" dia. x 1 1/2" long, 8dx1 1/2 = 0.131" dia. x 1 1/2" long. See pages 22-23 for other nail sizes and information.

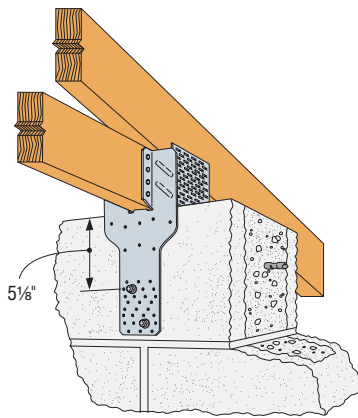

Typical H10S Installation

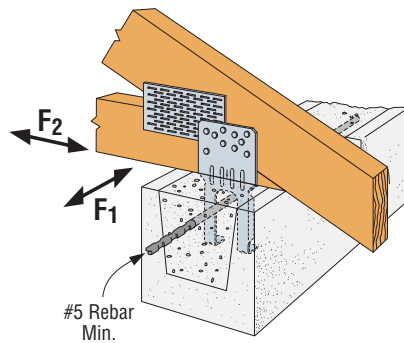

LTA2 Perpendicular to Wall Installation

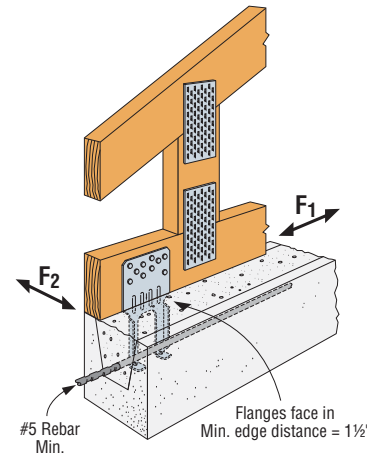

LTA2 Parallel to Wall Installation

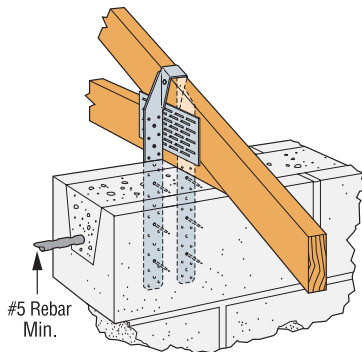

1 H16S Installed into Masonry

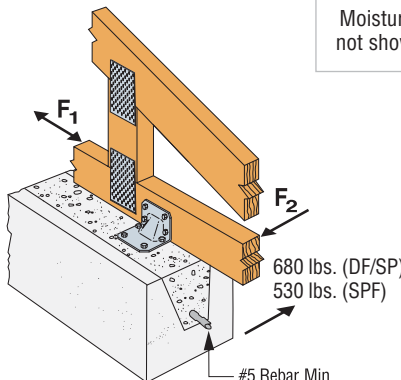

2 HGAM10 Installed into Masonry

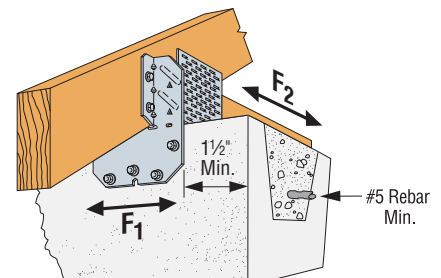

3 HM9 Attaching Truss to Masonry

META/HETA/HHETA/HETAL/DETAL/TSS Embedded Truss Anchors and Truss Seat Snap-In

The embedded truss anchor series provides an engineered method to properly attach roof trusses to concrete and masonry walls. The products are designed with staggered nail patterns for greater uplift resistance. Information regarding the use of two anchors on single- and multi-ply trusses is included.

The TSS, a companion product of the META, provides a moisture barrier between the concrete and truss. The preassembled unit is riveted with no height adjustment.

The DETAL20 is a high capacity embedded truss anchor for attachment of single-ply trusses to concrete and masonry walls. It combines dual embedded anchors with a structural moisture-barrier seat that is partially embedded in the concrete or grout. This seat serves to protect the truss and also provides additional lateral and uplift capacity. The embedded anchors are pre-attached to the moisture barrier through slots that allow for a slight amount of adjustability, providing flexibility during installation to avoid rebar. The moisture-barrier seat includes tabs at each end for optional attachment to the form board in concrete tie-beam applications.

MATERIAL: HHETA-14 gauge; HETA-16 gauge; HETAL-strap 16 gauge, truss seat 18 gauge; META-18 gauge; TSS-22 gauge; DETAL-16 gauge (Barrier-18 gauge)

FINISH: Galvanized. Some products available in ZMAX® coating; see Corrosion Information, pages 13-15.

INSTALLATION: • Use all specified fasteners. See General Notes.

- The META, HETA and HHETA are embedded 4" into a 6" min. concrete beam or 8" nominal grouted block wall; HETAL is embedded 5 1/16"; DETAL is embedded 4 1/2".
- The DETAL20 is installed centered and flush on top of an 8" masonry bond beam or concrete tie beam. The moisture barrier seat bears on masonry face shell or concrete tie beam form boards; the two flanges embed into grout or concrete.
- The TSS moisture barrier may be preattached to the truss using 6d commons.
- For mislocated truss anchors which are greater than 1/8" but less than 1 1/2" from the face of the truss, a shim must be provided. Shim design by Truss Engineer. When gap is greater than 1 1/2", install new anchors.
- In double embedded anchor installations, do not install fasteners where the straps overlap when wrapped over the truss heel.

CODES: See page 12 for Code Reference Key Chart.

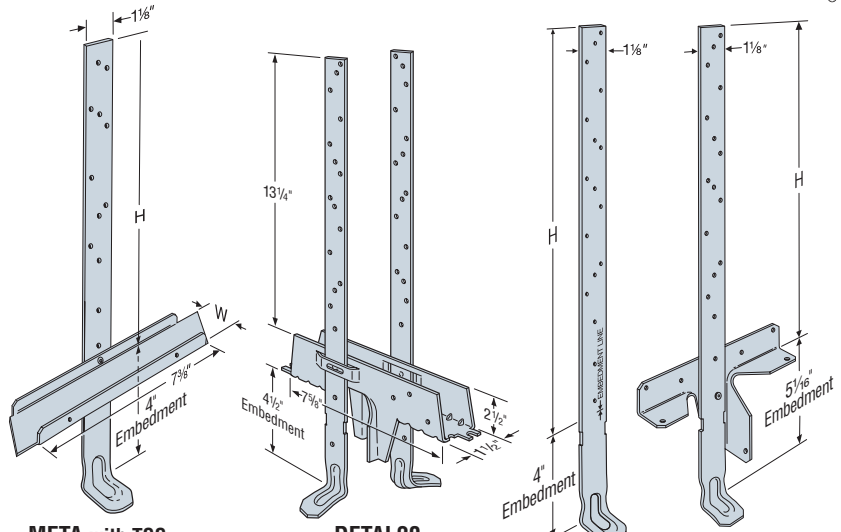

META with TSS

DETAL20
U.S. Patent 7,987,636

HETA20
(HHETA similar)

HETAL

Model No.	W
TSS2	1 3/4"
TSS2-2	3 1/4"
TSS4	3 3/4"

Moisture barrier not shown (Typ.)

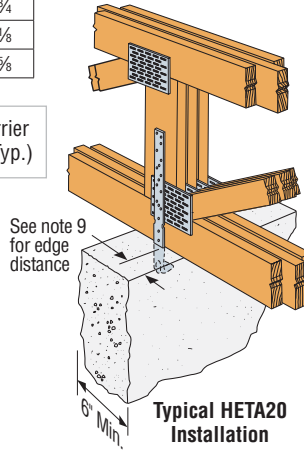

Typical HETA20 Installation

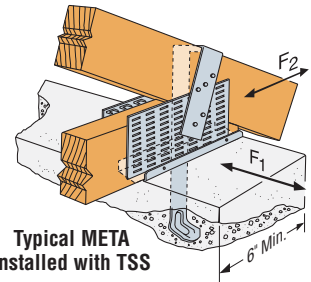

Typical META Installed with TSS

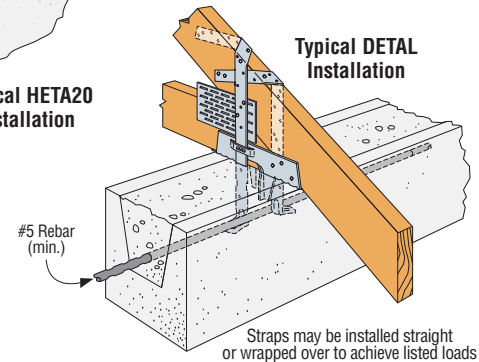

Typical DETAL Installation

These products are available with additional corrosion protection. Additional products on this page may also be available with this option, check with Simpson Strong-Tie for details.

Single Embedded Anchor Installation

Model No.	H (in.)	SP Uplift Load 160 Load Duration Increase				Lateral Loads (160)		Code Ref.
		10dx1 1/2"		16d		F ₁	F ₂	
		Quantity	Load	Quantity	Load			
META12	8	7	1450	6	1450	340	725	F27
META14	Discontinued - See META12 and META16							
META16	12	7	1450	6	1450	340	725	
META18	14	7	1450	6	1450	340	725	
META20 ⁶	16	7	1450	6	1450	340	725	
META22	18	7	1450	6	1450	340	725	
META24	20	7	1450	6	1450	340	725	
META40	36	7	1450	6	1450	340	725	
HETA12	8	7	1520	7	1780	340 ⁷	725	
HETA16	12	9	1810	8	1810	340	725	
HETA20 ⁶	16	9	1810	8	1810	340	725	
HETA24	20	9	1810	8	1810	340	725	
HETA40	36	9	1810	8	1810	340	725	
HHETA16	12	10	2235	9	2235	340 ⁷	815	
HHETA20 ⁶	16	10	2235	9	2235	340 ⁷	815	
HHETA24	20	10	2235	9	2235	340 ⁷	815	
HHETA40	36	10	2235	9	2235	340 ⁷	815	
HETAL12	7	10 ⁴	1085	10 ⁴	1270	415 ⁵	1100	
HETAL16	11	14 ⁴	1810	13 ⁴	1810	415 ⁵	1100	
HETAL20	15	14 ⁴	1810	13 ⁴	1810	415 ⁵	1100	

1. Loads have been increased for wind or seismic loading. Reduce where other loads govern.
2. Minimum f'_c = 2500 psi. Minimum f'_m = 1500 psi.
3. For simultaneous loads in more than one direction, the connector must be evaluated as described in Note e, page xx under Instructions to the Designer.
4. Five nails must be installed into the truss seat of the HETAL.
5. Parallel-to-wall load towards face of HETAL is 1975 lbs.
6. It is acceptable to use a reduced number of fasteners provided that there is a reduction in uplift load capacity. See example on page 190. Lateral loads do not apply when fewer than 7 fasteners are used with the HETA and HHETA anchors or less than 6-16d or 7-10dx1 1/2 fasteners are used with the META anchor.
7. The HHETA allowable F₁ load can be increased to 435 lbs. if the strap is wrapped over the truss and a minimum of 12 nails are installed.
8. Minimum spacing for multiple anchor installation is 2 times the embedment depth for full load. See Double Embedded Anchor Installation table on page 181 for loads on closer spaced anchors.
9. Minimum edge distance for HETA/META is 1 1/2" for concrete and 2" for masonry.
10. **NAILS:** 16d = 0.162" dia. x 3 1/2" long, 10dx1 1/2 = 0.148" dia. x 1 1/2" long. See pages 22-23 for other nail sizes and information.

META/HETA/HHETA/HETAL/DETAL/TSS Embedded Truss Anchors and Truss Seat Snap-In

Double Embedded Anchor Installation

Model No.	Qty.	Application	SP Uplift Load Capacity (160)				Lateral Loads (160) ⁹		Code Ref.
			1 Ply		2 or 3 Ply		F ₁	F ₂	
			Fasteners ⁵	Load	Fasteners ⁵	Load			
DETAL20	1	CMU	18-10dx1½	2480	—	—	2000 ⁹	1370	F27
		Concrete	18-10dx1½	2480	—	—	2000	1505	
META	2	CMU	10-10dx1½	1985	14-16d	1900	1210 ⁷	1160	
		Concrete	10-10dx1½	1985	14-16d	2565	1210 ⁷	1160	
HETA	2	CMU	10-10dx1½	2035	12-16d	2500	1225 ⁷	1520	
		Concrete	10-10dx1½	2035	12-16d	2700	1225 ⁷	1520	
HHETA	2	CMU	10-10dx1½	2035	12-16d	2500	1225 ⁷	1520	
		Concrete	10-10dx1½	2035	14-16d ⁸	3350	1225 ⁷	1520	

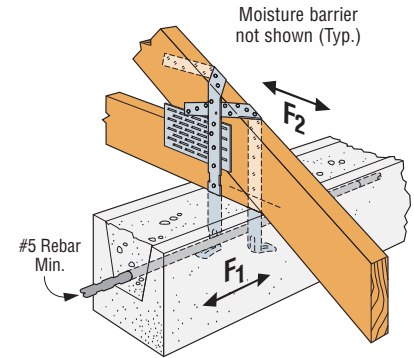

Typical Installation with two METAs

1. Loads include a 60% load duration increase on the fasteners for wind or seismic loading.
2. Minimum $f_c = 2500$ psi. Minimum $f_m = 1500$ psi.
3. For simultaneous loads in more than one direction, the connector must be evaluated as described in Note e, page xx under General Instructions for the Designer.
4. Install with spoons facing outward and straps spaced no more than ½" wider than the truss width.
5. The DETAL20 requires 6-10dx1½" nails in the truss seat and 6-10dx1½" nails into each strap. For all other models, install half of the required fasteners in each strap.
6. Lateral loads for META, HETA and HHETA anchors apply only to 2- or 3-ply applications with anchors spaced a minimum of 3" apart. For single-ply applications use lateral loads from the Single Embedded Anchor Installation table on page 180. DETAL lateral loads apply for single-ply application.
7. F₁ lateral loads listed may cause an additional ¼" deflection beyond the standard ½" limit where the straps are installed not wrapped over the heel as shown.
8. Two HHETA anchors may be installed in a concrete tie beam on a 2- or 3-ply truss with 2 fewer nails for an allowable uplift load of 3050 lbs.
9. Noted F₁ lateral loads for the DETAL20 may cause an additional ½" deflection beyond the standard ½" limit.
10. Single-ply trusses may use either 10dx1½ or 16d nails with allowable loads limited to the single-ply column. 2- or 3-ply trusses shall use 16d nails.
11. **NAILS:** 16d = 0.162" dia. x 3½" long, 10dx1½ = 0.148" dia. x 1½" long. See pages 22-23 for other nail sizes and information.

MSTAM/MSTCM Straps Ties

MSTAM and MSTCM models are designed for wood to masonry applications.

The MSTC series has countersunk nail slots for a lower nailing profile.

FINISH: Galvanized. Some products are available in stainless steel or ZMAX[®] coating; see Corrosion Information, pages 13-15.

INSTALLATION:

- Use all specified fasteners. See General Notes.
- Attaches to grouted concrete block and wood framing.
- Minimum end and edge distance for Titen[®] screws is 1½".

CODES: See page 12 for Code Reference Key Chart.

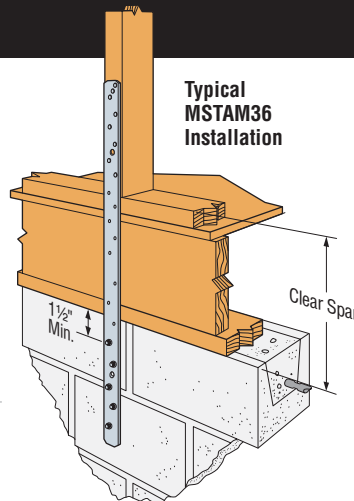

Typical MSTAM36 Installation

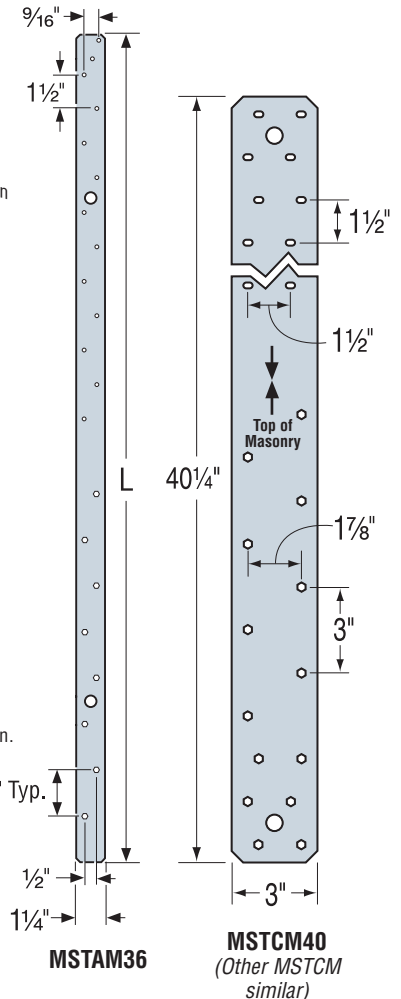

These products are available with additional corrosion protection. Additional products on this page may also be available with this option, check with Simpson Strong-Tie for details.

Masonry Application

Model No.	Ga	Dimensions		Fasteners (Total)			Allowable Tension/Uplift Loads		Code Ref.
		W	L	Nails	CMU	Concrete	DF/SP (160)	SPF/HF (160)	
MSTAM24	18	1¼	24	9-10d	5-¼x2¼ Titen	5-¼x1¾ Titen	1500	1500	F27
MSTAM36	16	1¼	36	13-10d	8-¼x2¼ Titen	8-¼x1¾ Titen	1870	1870	
MSTCM40	16	3	40¼	26-16d sinkers	14-¼x2¼ Titen	14-¼x1¾ Titen	4220	4220	
MSTCM60	16	3	59½	26-16d sinkers	14-¼x2¼ Titen	14-¼x1¾ Titen	4220	4220	

1. Loads include a 60% load duration increase on the fasteners for wind or earthquake loading.
2. Minimum edge distance 1½" using Titen[®] screws.
3. Minimum $f_m = 1500$ psi and $f_c = 2500$ psi.
4. Products shall be installed such that the Titen screws are not exposed to the weather.
5. See page 173 for Titen screw information.
6. **NAILS:** 16d Sinker = 0.148" dia. x 3¼" long, 10d = 0.148" dia. x 3" long. See pages 22-23 for other nail sizes and information.

Floor-to-Floor Clear Span Table

Model No.	Clear Span	Fasteners (Total)			Allowable Tension/Uplift Loads		Code Ref.
		Nails	CMU	Concrete	DF/SP (160)	SPF/HF (160)	
MSTAM36	16 or 18	7-10d	4-¼x2¼ Titen	4-¼x1¾ Titen	1400	1210	F27
MSTCM40	16 or 18	14-16d sinkers	10-¼x2¼ Titen	10-¼x1¾ Titen	2800	2420	
MSTCM60	22¼	26-16d sinkers	14-¼x2¼ Titen	14-¼x1¾ Titen	4220	4220	
MSTCM60	26¼	20-16d sinkers	14-¼x2¼ Titen	14-¼x1¾ Titen	3840	3320	

See notes above.

MTSM/HTSM Twist Straps

The MTSM and HTSM offer high strength truss-to-masonry connections.

MATERIAL: MTSM—16 gauge; HTSM—14 gauge

FINISH: Galvanized. See Corrosion Information, pages 13-15.

INSTALLATION:

- Use all specified fasteners. See General Notes.
- Installs with hex-head Titen® screws.
- Attach to either side of grouted concrete block with a minimum one #5 rebar horizontal.

CODES: See page 12 for Code Reference Key Chart.

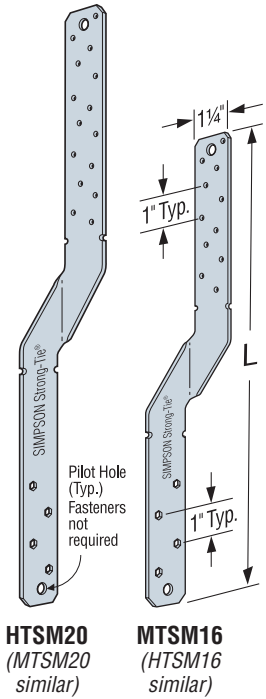
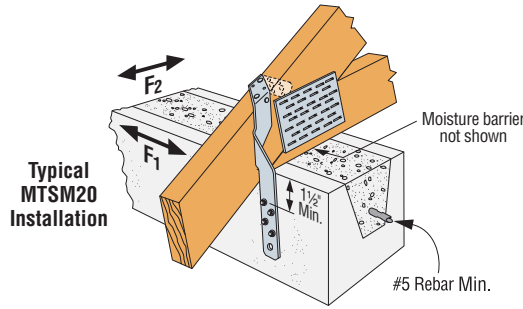

Model No.	L	Fasteners ²			DF/SP Allowable Uplift Loads ¹		SPF/HF Allowable Uplift Loads ¹		Allowable Lateral Loads (DF/SP/SPF/HF)		Code Ref.
		Truss	CMU	Concrete	10d	10dx1½	10d	10dx1½	F1	F2	
					(160)	(160)	(160)	(160)	(160)	(160)	
MTSM16	16	7-10d	4-¼x2¼ Titen	4-¼x1¼ Titen	860	860	750	750	235 ⁸	90 ⁸	F27
MTSM20	20	7-10d	4-¼x2¼ Titen	4-¼x1¼ Titen	860	860	750	750			
HTSM16	16	8-10d	4-¼x2¼ Titen	4-¼x1¼ Titen	1175	1175	1020	1020			
HTSM20	20	10-10d	4-¼x2¼ Titen	4-¼x1¼ Titen	1175	1175	1020	1020			

1. Loads have been increased for wind or earthquake loading with no further increase allowed. Reduce where other loads govern.
2. Twist straps do not have to be wrapped over the truss to achieve the allowable load.
3. Minimum edge distance for Titen screw is 1½".
4. See page 173 for Titen screw information.
5. Table allowable loads were determined using test ultimate/3 or fastener calculation values.
6. Products shall be installed such that the Titen screws are not exposed to the weather.
7. Minimum f_m = 1500 psi and f_c = 2500 psi.
8. Lateral loads apply when on the wall side Titen screws are installed into the first four hexagonal holes from the bend line and on the truss/rafter the first seven nail holes near the bend line are filled. Any other fasteners required can be installed in any open hole.
9. **NAILS:** 10d = 0.148" dia. x 3" long, 10dx1½ = 0.148" dia. x 1½" long. See pages 22-23 for other nail sizes and information.

MGT/HGT Girder Tiedowns

The MGT and HGT series are girder tie downs for moderate to high load applications that are typically installed prior to roof sheathing. The MGT wraps over the heel and is anchored on one side of the truss. The HGT straddles the heel and anchors on both sides of the truss. The HGT is field adjustable, making it suitable for trusses with top chord slopes up to 8/12. The HGT is available in sizes for 2-, 3- and 4-ply widths.

MATERIAL: MGT—12 gauge; HGT—7 gauge

FINISH: MGT—Galvanized; HGT—Simpson Strong-Tie® gray paint

INSTALLATION: • Use all specified fasteners. See General Notes.

- When the HGT-3 is used with a 2-ply girder or beam, shimming is required and must be fastened to act as one unit.
- Attach to grouted concrete block with a minimum one #5 rebar horizontal in the top lintel block.
- See page 204 for wood applications.

CODES: See page 12 for Code Reference Key Chart.

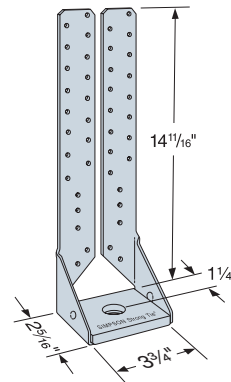

MGT

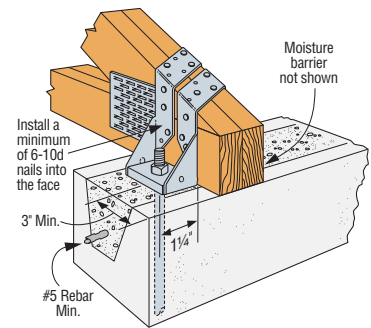

Typical MGT Installation

Model No.	W	O.C. Dim Between Anchors	Fasteners		DF/SP Allowable Uplift Loads (160)	SPF/HF Allowable Uplift Loads (160)	Code Ref.
			Concrete/CMU	Girder			
MGT	3¾	—	1-5/8	22-10d	3965	3330	F26
HGT-2	3 5/16	5¾	2-3/4	16-10d	10980	6485	I20, F19
HGT-3	4 5/16	7¾	2-3/4	16-10d	10530	9035	
HGT-4	6 5/16	9	2-3/4	16-10d	9250	9250	

1. Attached members must be designed to resist applied loads.
2. Minimum f_m = 1500 psi and f_c = 2500 psi.
3. To achieve the loads listed for the MGT and HGT, anchorage into a 8" wide concrete tie-beam or grouted and reinforced CMU tie-beam can be made using Simpson Strong-Tie® SET Epoxy-Tie® adhesive with a minimum embedment depth of 12". Vertical reinforcement may be required to transfer the loads per Designer.
4. Allowable loads have been increased for wind or earthquake loading with no further increase allowed; reduce where other loads govern.
5. The MGT can be installed with straps vertical for full table load provided all specified nails are installed to either a solid header or minimum double 2x6 web.
6. Table allowable loads were determined using tested lowest ultimate/3 or fastener calculation values.
7. **NAILS:** 10d = 0.148" dia. x 3" long. See pages 22-23 for other nail sizes and information.

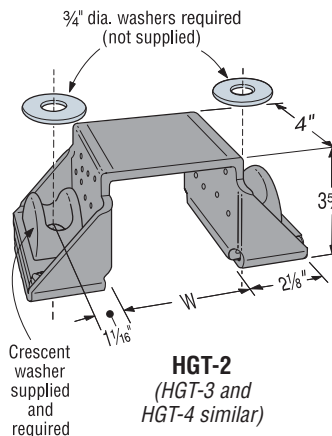

HGT-2 (HGT-3 and HGT-4 similar)

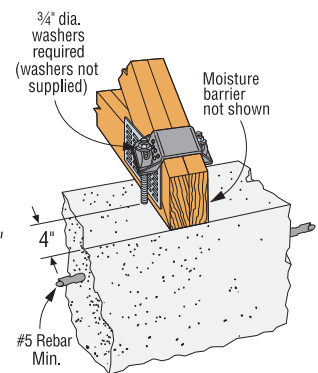

Typical HGT-2 Installation into Concrete

FGTR/LGT/VGT Retrofit Girder Tie-downs



The LGT, VGT and FGTR products are moderate to high load capacity girder tie-downs for new or retrofit applications.

LGT connectors provide a low profile connection to the wall for easy installation of drywall. Simple to install and can be installed on the inside or outside of the wall.

The Variable Girder Tie-down (VGT) is a higher capacity alternative to the LGT and MGT for girder trusses. It attaches with Simpson Strong-Tie® Strong-Drive® SDS Heavy-Duty Connector screws to the side of truss and features a predeflected crescent washer that allows it to accommodate top chord pitches up to 8/12. The VGT is also available with one flange concealed for attachment to trusses with no tail.

The Face Mount Girder Tie-Down (FGTR) is a non-pitch specific girder tie-down that offers the highest uplift capacity for retrofit applications. The FGTRHL/R is designed for corner hip applications.

MATERIAL: VGT—7 gauge; LGT2—14 gauge; LGT3/LGT4—12 gauge; FGTR—Straps: 7 gauge, Plate: 3 gauge

FINISH: VGT, LGT—Galvanized; FGTR—Powder Coated

INSTALLATION: • Use all specified fasteners. See General Notes.

- Connectors attached using Titen® screws shall have hex heads.
- To achieve the loads listed in the table below, the product shall be attached to a grouted and reinforced block wall or a reinforced concrete wall designed by others to transfer the high concentrated uplift loads to the foundation.
- Strong-Drive SDS screws included with LGT3, LGT4, VGT Series and FGTR Series.

VGT/FGTR:

- Screw holes are configured to allow for double installation on a two-ply (minimum) truss.
- The product can be installed in a single application or in pairs to achieve a higher uplift capacity.
- Can be installed on roof pitches up to 8/12 or on a bottom chord designed to transfer the loads.
- FGTR —Only 2 of the 4 holes provided on each strap are required to be filled to achieve the catalog loads. The first Titen HD® anchor ½"x5" (THD) shall be installed a minimum of 4" from the top of the wall. Fasteners shall not be installed in adjacent holes.
- VGT—When installed on trusses with no overhangs, specify VGTR/L.
- VGT—Install washer component (provided) so that top of washer is horizontal as well as parallel with top of wall.

OPTIONS: LGT3 is available with reduced widths of $W = 4\frac{13}{16}$ — order as LGT3N-SDS2.5.

CODES: See page 12 for Code Reference Key Chart.

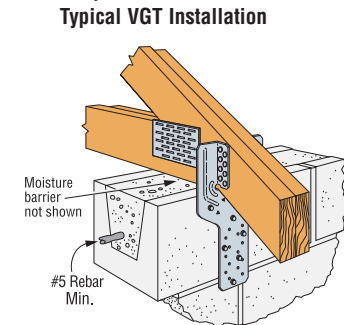
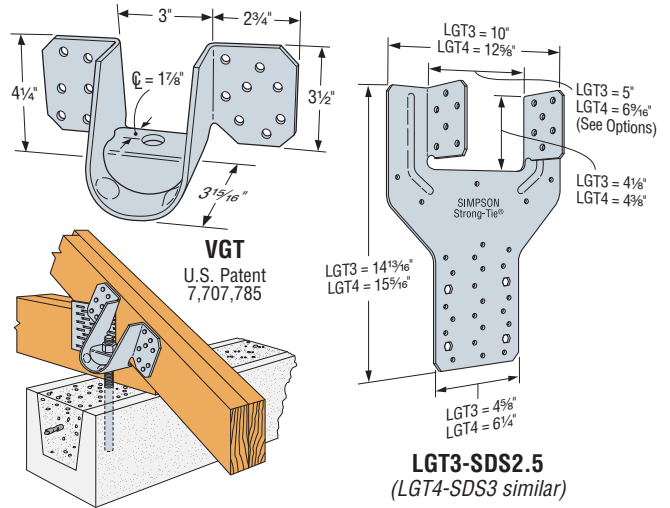

Model No.	Qty.	No. of Plies	Fasteners		Allowable Uplift Load (160)		Code Ref.	
			To Girder	To Wall	DF/SP	SPF/HF		
LGT2	1	2 ply	16-16d Sinker	7-¼x2¼ Titen ¹¹	2150	1850	F26	
LGT3-SDS2.5	1	3 ply	12-SDS ¼"x2½"	4-¾x5 Titen HD	3285	2365		
LGT4-SDS3	1	4 ply	16-SDS ¼"x3"	4-¾x5 Titen HD	3285	2365		
VGT	1	2 ply min.	16-SDS ¼"x3"	1-5/8"	4940	3555		
		2 ply min.	32-SDS ¼"x3"	2-5/8"	7185	5175		
		3 ply min.	32-SDS ¼"x3"	2-5/8"	8890	6400		
VGTL/R	1	2 ply min.	16-SDS ¼"x3"	1-5/8"	2230	1605		
			32-SDS ¼"x3"	2-5/8"	5545	3990		
FGTR	1	2 ply min.	18-SDS ¼"x3"	2-½x5 Titen HD	5000	3600		F27
			36-SDS ¼"x3"	4-½x5 Titen HD	9400	6770		
FGTRHL/R	1	2 ply min.	18-SDS ¼"x3"	2-½x5 Titen HD	3850	2770		

1. Allowable loads have been increased 60% for wind or earthquake loading with no further increase allowed; reduce where other loads govern.
2. To achieve the loads listed for the VGT single and double connector options, anchorage into a 8" wide concrete tie-beam or grouted and reinforced CMU tie-beam can be made using Simpson Strong-Tie® SET Epoxy-Tie® adhesive with a minimum embedment depth of 12", a minimum end distance of 12" and centered in the 8" member. Vertical reinforcement may be required to transfer the loads per Designer.
3. Minimum concrete strength f'_c shall be 2500 psi. CMU shall have a minimum grout strength of 2500 psi with standard ASTM C90 units and type N or S mortar.
4. FGTR—Minimum edge distance for Titen HD anchor is 4".
5. FGTR—Titen HD anchors should be spaced in every other hole on the part.
6. FGTR—The Titen HD anchors and SDS Heavy-Duty Connector screws are provided with the part.

7. LGT2— F_1 load = 700, F_2 load = 170.
8. See page 173 for Titen screw information.
9. Table allowable loads were determined using tested lowest ultimate/3 or fastener calculation values.
10. Products shall be installed such that the Titen screws and Titen HD anchors are not exposed to the weather.
11. For concrete wall applications use ¼x1¼ Titen screws.
12. Simpson Strong-Tie® Strong-Drive® SDS Heavy-Duty Connector screws are permitted to be installed through metal truss plates as approved by the Truss Designer, provided the requirements of ANSI/TPI 1-2007 Sections 7.5.3.4 and 8.9.2 are met (pre-drilling required through the plate using a maximum of 5/32" bit).
13. **NAILS:** 16d Sinker = 0.148" dia. x 3¼" long.
See pages 22-23 for other nail sizes and information.

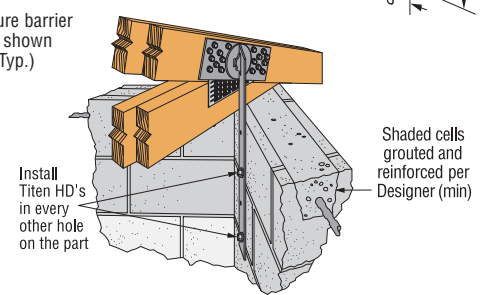
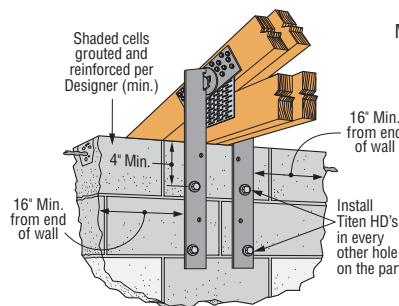
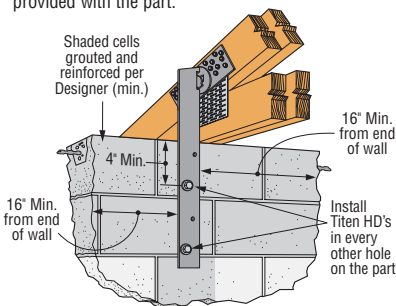

C-C-2015 © 2015 SIMPSON STRONG-TIE COMPANY INC. PRINTED 12/14

Masonry Connectors

CCQM/CCTQM/ECCLQM/CCCQM/ECCLQMD Column Caps for CMU and Concrete Piers

The CCQM/CCTQM/CCCQM/ECCLQM embedded column caps are designed for use in raised pier foundations and applications where heavy timbers rest on concrete or concrete block columns. The heavy-gauge beam seats and unique SSTB-style anchor bolts provide the high uplift and lateral resistance needed to help resist high wind events. The new ECCLQMD is a variation that incorporates an additional seat to support a third member at the corner connection. **The new CCCQM is a variation that incorporates a stirrup on each side for intermediate support beams perpendicular to the main channel.**

Framing is fastened with Simpson Strong-Tie® Strong-Drive® SDS Heavy-Duty Connector screws (included) that install with no pre-drilling and feature a corrosion-resistant double barrier coating.

CCQM – Intended for use along a floor support beam and non-corner locations.

CCTQM – Also for use along a floor support beam and non-corner locations with a side stirrup that accommodates intermediate support beams coming at 90 degrees.

CCCQM – For use along a floor support beam with a stirrup on each side of the main channel that accommodates intermediate support beams coming at 90 degrees.

ECCLQM-KT – Intended for use at the corners with MSTQM straps to make the connection from the ECCLQM to the wall framing above.

ECCLL/RQMD-KT – Ideal for applications where a member is needed off the corner of the structure, such as a deck joist/beam.

MATERIAL: Column caps—7 gauge; strap (MSTQM)—12 gauge

FINISH: Column caps—Hot-dip galvanized or Simpson Strong-Tie® gray paint; strap (MSTQM) = galvanized (ZMAX®)

INSTALLATION: • Use all specified fasteners. See General Notes.

• Reference F-C-CCQM-WS special order worksheet for ordering assistance.

OPTIONS: • For variable widths on side stirrups specify W3 or W4 (3/4" to 7") and add an "X" to the end of the core model name.

Example: CCTQM5.50X-SDSG, W3 = 3/8"

CODES: See page 12 for Code Reference Key Chart.

Dimensions

Model No.	Main Channel Width (W1)	Side Stirrup Width (W3 & W4)	Main Channel Length (L1)	Side Stirrup Length (L2)
CCQM3.62-SDSHDG	3 3/8"	—	11"	—
CCQM4.62-SDSHDG	4 1/8"	—	11"	—
CCQM5.50-SDSHDG	5 1/2"	—	11"	—
CCTQM3.62-SDSG	3 3/8"	3 3/8"	11 1/2"	4"
CCTQM4.62-SDSG	4 1/8"	4 1/8"	13 1/2"	4"
CCTQM5.50-SDSG	5 1/2"	5 1/2"	13 1/2"	4"
CCCQM3.62-SDSG	3 3/8"	3 3/8"	11 1/2"	4"
CCCQM4.62-SDSG	4 1/8"	4 1/8"	13 1/2"	4"
CCCQM5.50-SDSG	5 1/2"	5 1/2"	13 1/2"	4"
ECCLQM3.62G-KT ¹	3 3/8"	3 3/8"	11 1/2"	7 3/4"
ECCLQM4.62G-KT ¹	4 1/8"	4 1/8"	11 1/2"	7 3/4"
ECCLQM5.50G-KT ¹	5 1/2"	5 1/2"	11 1/2"	7 3/4"
ECCLQMD3.62G-KT	3 3/8"	3 3/8"	16 1/2"	7 3/4"
ECCLQMD4.62G-KT	4 1/8"	4 1/8"	16 1/2"	7 3/4"
ECCLQMD5.50G-KT	5 1/2"	5 1/2"	16 1/2"	7 3/4"

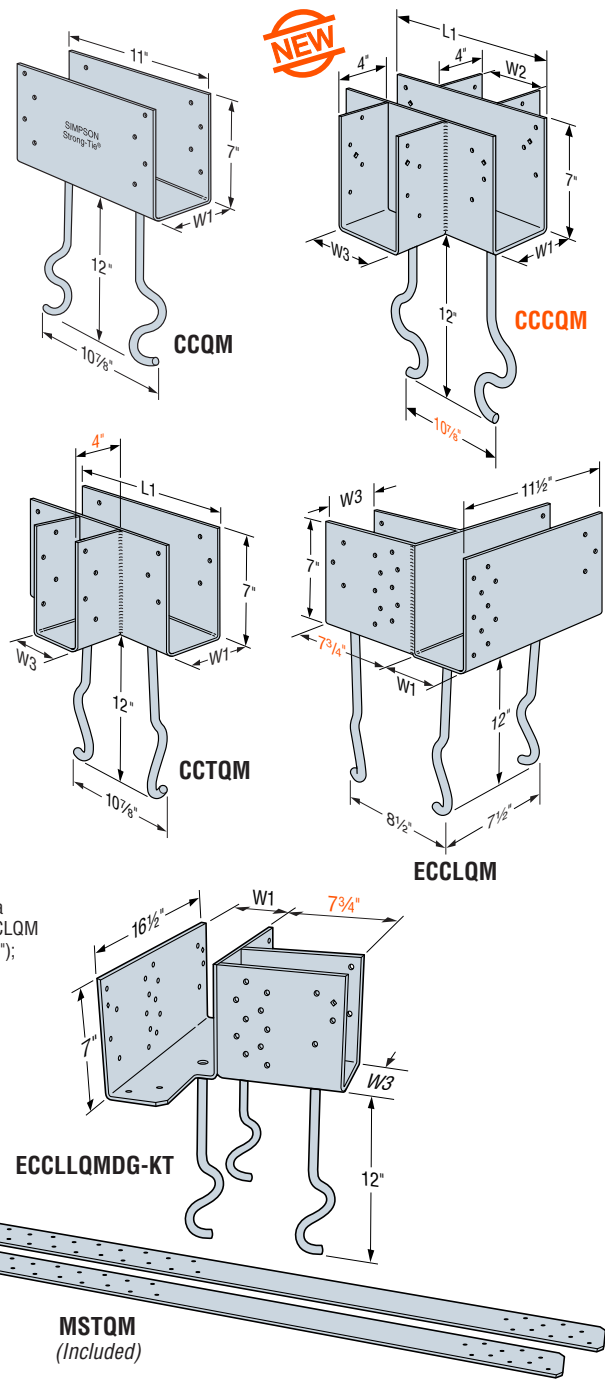

1. The MSTQM strap is a component of the ECCLQM kits. It is 12 ga. (0.101"); 3" wide and 48" long.

These products feature additional corrosion protection.

Model No.	No. of 1/4"x2 1/2" SDS Screws			16" Square Grout-Filled CMU Pier ^{3,6}				16" Square CMU Shell Filled with 3000 psi Concrete ^{3,7}				Deck Joist Connection		Code Ref.
				Uplift (160)			Lateral (160)	Uplift (160)			Lateral (160)	Download	Uplift	
	Main Beam	Side Beam	Deck Beam	Main Beam	Side Beam	Total		Main Beam	Side Beam	Total				
CCQM-SDSHDG	12	—	—	6750	—	6750	2460	6855	—	6855	2770	—	—	F24
CCTQM-SDSG	12	8	—	6750	5375	6750	2460	6855	6720	6855	2770	—	—	
CCCQM-SDSG	12	8	—	6750	5375	6750	2460	6855	6720	6855	2770	—	—	
ECCLQMG-KT ⁸	16	16	—	6240	6240	7300	2220	6240	6240	8260	2680	—	—	
ECCLQMDG-KT	16	16	6	6240	6240	7300	2220	6240	6240	8260	2680	5475	2010	

- The allowable loads have been increased for wind or earthquake loading with no further increase allowed.
- Total uplift load and lateral load is based on tested anchor failure in the pier.
- Allowable loads are based on either a 16" square grout-filled CMU pier with f_m of 1500 psi or a 16" square CMU shell filled with 3000 psi concrete. A minimum of (4) #7 vertical rebars are required. The Designer shall design and detail the CMU/concrete pier to resist all forces including uplift, shear, and moment.
- Pier height per Designer.
- Side beam and main beam uplift loads assume DF members and are not additive.

- The allowable loads listed for grout-filled CMU apply to solid concrete piers of 2500 psi concrete a minimum of 16" square.
- The allowable loads listed for CMU shell-filled with 3000 psi concrete apply to solid concrete piers of 3000 psi concrete a minimum of 12" square.
- The ECCLQM-KT is a kit packaged with (2) MSTQM straps and (32) Strong-Drive 1/4"x2 1/2" SDS Heavy-Duty Connector screws. One strap may be installed on each face of the ECCLQM (as shown), using the Strong-Drive SDS Heavy-Duty Connector screws into the beams and 26-16dx2 1/2" nails (not provided) into the wall framing. The MSTQM strap's allowable tension load is 6240 lbs.
- Any side stirrup not fully supported by grout or concrete filled CMU has an allowable down load of 7000 lbs.

CCQM/CCTQM/ECCLQM/CCCQM/ECCLQMD Column Caps for CMU and Concrete Piers

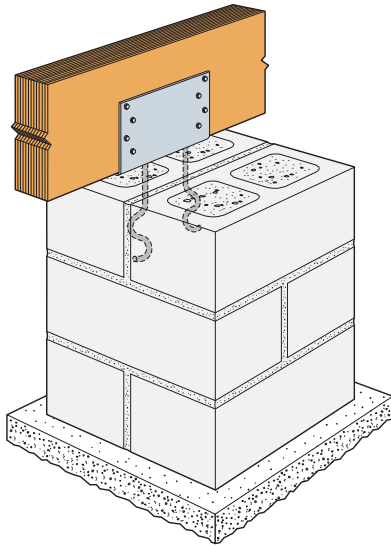

Typical CCQM Installation

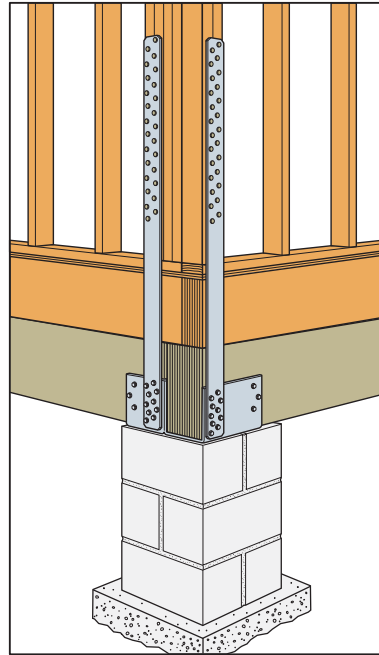

Typical ECCLQM Installation

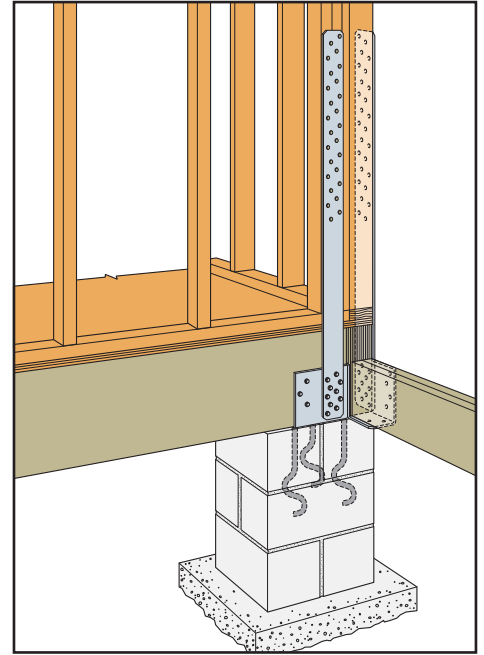

Typical ECCLQMD-KT Installation

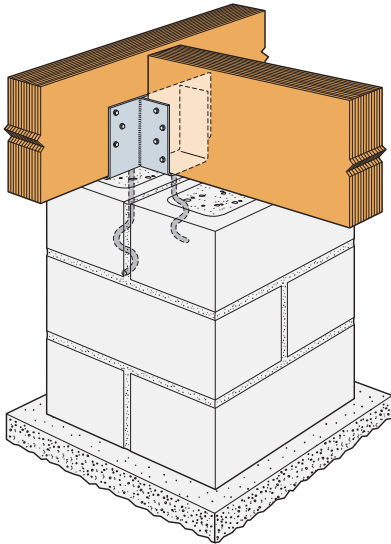

Typical CCTQM Installation

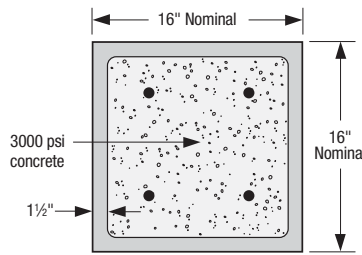

16" Square CMU Pilaster Filled with 3000 psi Concrete
(Plan View)

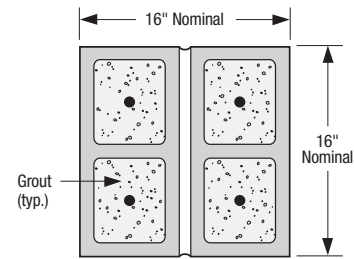

16" Square Grout-Filled CMU
(Plan View)

Main channel of CCCQM cannot be centered when installed into 16" grout-filled CMU piers, layout considerations should be made accordingly

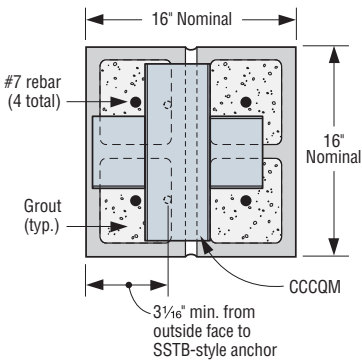

CCCQM Installed on 16" Square Grout-Filled CMU
(Plan View)

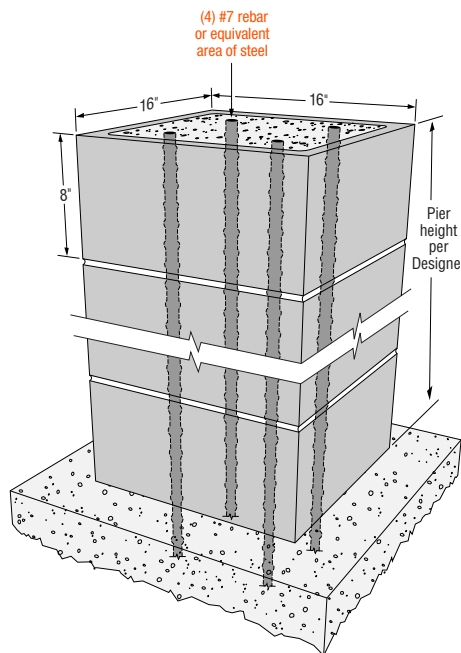

16" Square CMU Pilaster Filled with 3000 psi Concrete

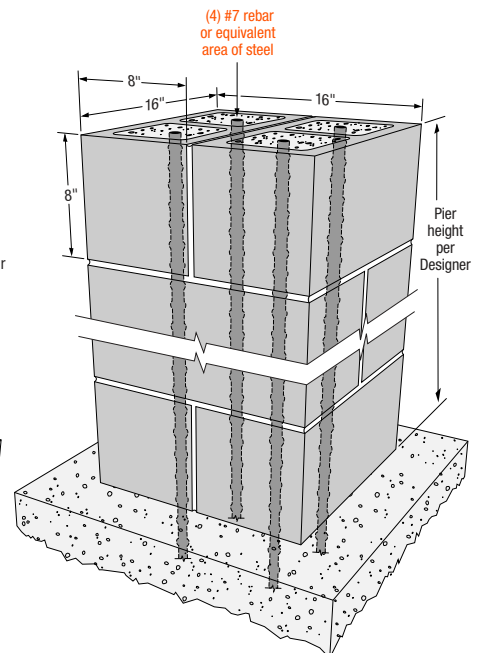

16" Square Grout-Filled CMU

HRS/ST/PS/HST/HTP/LSTA/LSTI/MST/MSTA/MSTC/MSTI Strap Ties

Straps are designed to transfer tension loads in a wide variety of applications.

HRS—A 12 gauge strap with a nailing pattern designed for installation on the edge of 2x members. The HRS416Z installs with Simpson Strong-Tie® Strong-Drive® SDS Heavy-Duty Connector screws.

LSTA and **MSTA**—Designed for use on the edge of 2x members, with a nailing pattern that reduces the potential for splitting.

LSTI—Light straps that are suitable where pneumatic-nailing is necessary through diaphragm decking and wood chord open web trusses.

MST—Splitting may be a problem with installations on lumber smaller than 3½"; either fill every nail hole with 10d x 1½" nails or fill every-other hole with 16d common nails. Reduce the allowable load based upon the size and quantity of fasteners used.

MSTC—High Capacity strap which utilizes a staggered nail pattern to help minimize wood splitting. Nail slots have been countersunk to provide a lower nail head profile.

FINISH: PS—HDG; HST3 and HST6—Simpson Strong-Tie® gray paint; all others—galvanized. Some products are available in stainless steel or ZMAX® coating; see Corrosion Information, pages 13-15.

INSTALLATION: Use all specified fasteners. See General Notes.
OPTIONS: Special sizes can be made to order. Contact Simpson Strong-Tie.

CODES: See page 12 for Code Reference Key Chart.
MSTC and RPS meet code requirements for reinforcing cut members (16 gauge) at top plate and RPS at sill plate. International Residential Code®— 2000/2006 R602.6.1 International Building Code®— 2000/2006 2308.9.8 (For RPS, refer to page 223.)

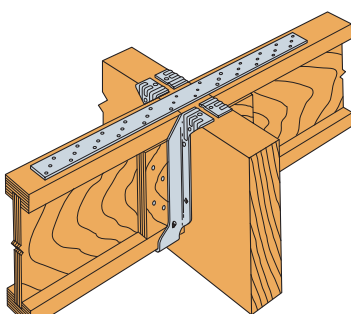
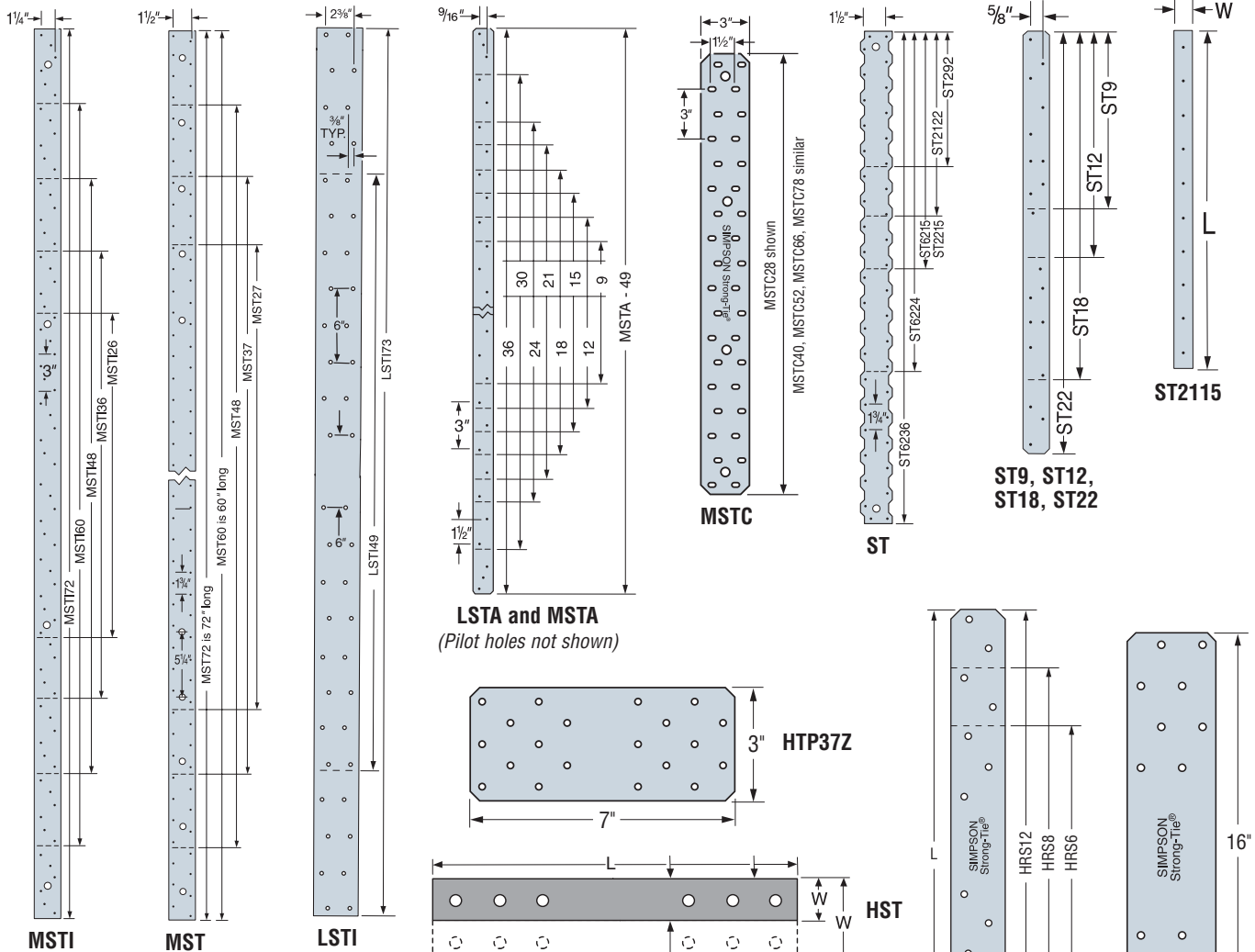

Typical MSTI Installation
(MIT hanger shown)
LSTI similar

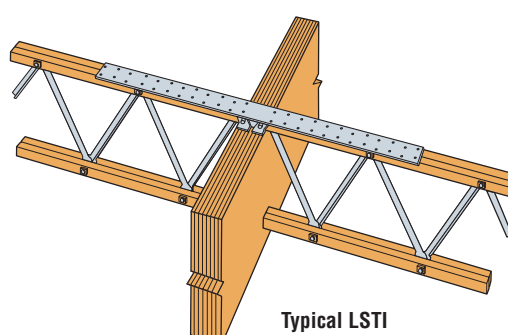

Typical LSTI Installation

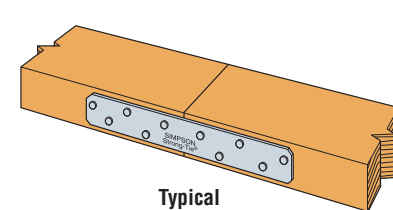

Typical HRS Installation

HRS/ST/PS/HST/HTP/LSTA/LSTI/MST/MSTA/MSTC/MSTI Strap Ties

CODES: See page 12 for Code Reference Key Chart.

These products are available with additional corrosion protection. Additional products on this page may also be available with this option, check with Simpson Strong-Tie for details.

These products are approved for installation with the Strong-Drive® SD Connector screw. See page 27 for more information.

Model No.	Ga	Dimensions		Fasteners (Total)	Allowable Tension Loads (DF/SP) (160)	Allowable Tension Loads (SPF/HF) (160)	Code Ref.
		W	L				
LSTA9	20	1¼	9	8-10d	740	635	I4, L3, L5, F2
LSTA12		1¼	12	10-10d	925	795	
LSTA15		1¼	15	12-10d	1110	950	
LSTA18		1¼	18	14-10d	1235	1110	
LSTA21		1¼	21	16-10d	1235	1235	
LSTA24		1¼	24	18-10d	1235	1235	
ST292		2½	9¾	12-16d	1265	1120	
ST2122		2½	12¼	16-16d	1530	1505	
ST2115		¾	16¾	10-16d	660	660	
ST2215		2½	16¾	20-16d	1875	1875	
LSTA30	18	1¼	30	22-10d	1640	1640	I4, L3, L5, F2
LSTA36		1¼	36	24-10d	1640	1640	
LSTI49		¾	49	32-10dx1½	2975	2555	
LSTI73		¾	73	48-10dx1½	4205	3830	
MSTA9		1¼	9	8-10d	750	645	
MSTA12		1¼	12	10-10d	940	810	
MSTA15		1¼	15	12-10d	1130	970	
MSTA18		1¼	18	14-10d	1315	1130	
MSTA21		1¼	21	16-10d	1505	1290	
MSTA24		1¼	24	18-10d	1640	1455	
MSTA30	16	1¼	30	22-10d	2050	1820	I4, L3, L5, F2
MSTA36		1¼	36	26-10d	2050	2050	
MSTA49		1¼	49	26-10d	2020	2020	
ST6215		2½	16¾	20-16d	2095	1900	
ST6224		2½	23¾	28-16d	2540	2540	
ST9		1¼	9	8-16d	885	760	
ST12		1¼	11¾	10-16d	1105	950	
ST18		1¼	17¾	14-16d	1420	1330	
ST22		1¼	21¾	18-16d	1420	1420	
MSTC28		3	28¼	36-16d sinkers	3455	2980	
MSTC40	3	40¼	52-16d sinkers	4745	4305		
MSTC52	3	52¼	62-16d sinkers	4745	4745		
HTP37Z	3	7	20-10dx1½	1850	1600	L5	
MSTC66	14	3	65¾	76-16d sinkers	5860	5860	I4, L3, L5, F2
MSTC78		3	77¾	76-16d sinkers	5860	5860	
ST6236		2½	33¼	40-16d	3845	3845	
HRS6	12	1½	6	6-10d	605	525	I4, L3, L5, F2
HRS8		1½	8	10-10d	1010	880	
HRS12		1½	12	14-10d	1415	1230	
MSTI26		2½	26	26-10dx1½	2745	2325	
MSTI36		2½	36	36-10dx1½	3800	3220	
MSTI48		2½	48	48-10dx1½	5065	4290	
MSTI60		2½	60	60-10dx1½	5080	5080	
MSTI72		2½	72	72-10dx1½	5080	5080	
HRS416Z	¾	16	16-SDS ¼"x1½"	2835	2305	170	

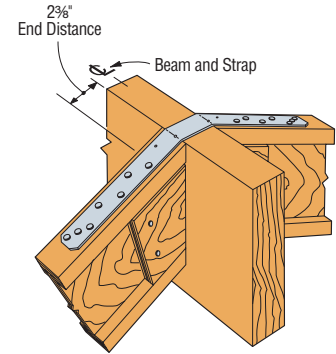

Typical LSTA Installation
(Hanger not shown)
Bend strap one time only,
max 12/12 joist pitch.

Model No.	Material Thickness Gauge	Dim.		Bolts Qty	Bolts Dia	Code Ref.
		W	L			
PS218	7 ga	2	18	4	¾	180
PS418		4	18	4	¾	
PS720		6¾	20	8	½	

- PS strap design loads must be determined by the Designer for each installation. Bolts are installed both perpendicular and parallel-to-grain. Hole diameter in the part may be oversized to accommodate the HDG. Designer must determine if the oversize creates an unacceptable installation.
- For allowable tension loads, see page 230.

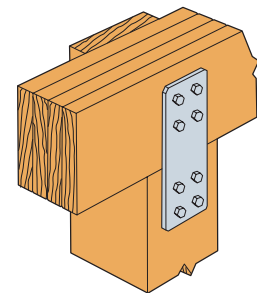
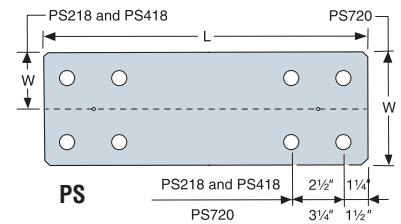

Typical PS720 Installation

- Loads include a 60% load duration increase on the fasteners for wind or earthquake loading.
- 10dx1½" nails may be substituted where 16d sinkers or 10d are specified at 100% of the table loads except where straps are installed over sheathing.
- 10d commons may be substituted where 16d sinkers are specified at 100% of table loads.
- 16d sinkers (0.148" dia. x 3¼" long) or 10d commons may be substituted where 16d commons are specified at 0.84 of the table loads.
- Use half of the nails in each member being connected to achieve the listed loads.
- Tension loads apply for uplift when installed vertically.
- NAILS:** 16d = 0.162" dia. x 3¾" long, 16d Sinker = 0.148" dia. x 3¼" long, 10d = 0.148" dia. x 3" long, 10dx1½" = 0.148" dia. x 1½" long. See pages 22-23 for other nail sizes and information.

HST/MST/MSTC/MSTA Strap Ties

CODES: See page 12 for Code Reference Key Chart.

These products are approved for installation with the Strong-Drive® SD Connector screw. See page 27 for more information.

Floor-to-Floor Clear Span Table

Model No.	Clear Span	Fasteners (Total)	Allowable Tension Loads (DF/SP)	Allowable Tension Loads (SPF/HF)
			(160)	(160)
MSTA49	18	26-10d	2020	2020
	16	26-10d	2020	2020
MSTC28	18	12-16d sinkers	1155	995
	16	16-16d sinkers	1540	1325
MSTC40	24	20-16d sinkers	2310	1985
	18	28-16d sinkers	2695	2320
	16	32-16d sinkers	3080	2650
	24	36-16d sinkers	3465	2980
MSTC52	18	44-16d sinkers	4235	3645
	16	48-16d sinkers	4620	3975
MSTC66	30	48-16d sinkers	4780	4120
	24	54-16d sinkers	5380	4640
	18	64-16d sinkers	5860	5495
	16	68-16d sinkers	5860	5840
MSTC78	30	64-16d sinkers	5860	5495
	24	72-16d sinkers	5860	5860
	18	76-16d sinkers	5860	5860
	24	14-16d	1725	1495
MST37	18	20-16d	2465	2135
	16	22-16d	2710	2345
MST48	24	26-16d	3215	2780
	18	32-16d	3960	3425
	16	34-16d	4205	3640
	30	34-16d	4605	3995
MST60	24	40-16d	5240	4700
	18	46-16d	6235	5405
MST72	30	48-16d	6505	5640
	24	54-16d	6730	6345
	18	62-16d	6730	6475

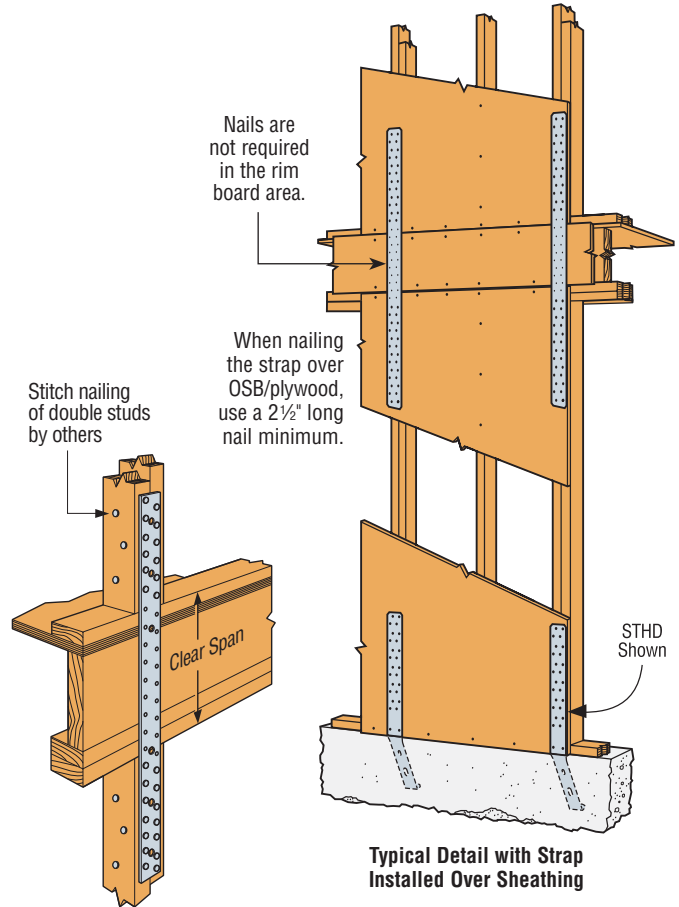

Floor-to-Floor Tie Installation showing a Clear Span

These products are available with additional corrosion protection. Additional products on this page may also be available with this option, check with Simpson Strong-Tie for details.

Model No.	Ga	Dimensions		Fasteners (Total)			Allowable Tension Loads (DF/SP)		Allowable Tension Loads (SPF/HF)		Code Ref.
		W	L	Nails	Bolts		Nails (160)	Bolts (160)	Nails (160)	Bolts (160)	
					Qty	Dia					
MST27	12	2 1/16	27	30-16d	4	1/2	3700	2165	3200	2000	14, L3, F2
MST37		2 1/16	37 1/2	42-16d	6	1/2	5080	3025	4480	2805	
MST48		2 1/16	48	50-16d	8	1/2	5310	3675	5190	3410	
MST60	10	2 1/16	60	68-16d	10	1/2	6730	4485	6475	4175	
MST72		2 1/16	72	68-16d	10	1/2	6730	4485	6475	4175	
HST2	7	2 1/2	21 1/4	—	6	5/8	—	5220	—	4835	
HST5		5	21 1/4	—	12	5/8	—	10650	—	9870	
HST3	3	3	25 1/2	—	6	3/4	—	7680	—	6660	
HST6		6	25 1/2	—	12	3/4	—	15470	—	13320	

1. Loads include a 60% load duration increase on the fasteners for wind or earthquake loading.
2. Install bolts or nails as specified by Designer. Bolt and nail values may not be combined.
3. Allowable bolt loads are based on parallel-to-grain loading and these minimum member thicknesses: MST-2 1/2"; HST2 and HST5-4"; HST3 and HST6-4 1/2".
4. Use half of the required nails in each member being connected to achieve the listed loads.
5. When installing strap over wood structural panel sheathing, use 2 1/2" long nail minimum.
6. Tension loads apply for uplift as well when installed vertically.
7. **NAILS:** 16d = 0.162" dia. x 3 1/2" long, 16d Sinker = 0.148" dia. x 3 1/4" long, 10dx1 1/2 = 0.148" dia. x 1 1/2" long. See pages 22-23 for other nail sizes and information.

CS/CMST Coiled Straps

CMSTC provides nail slots for easy installation; it can be cut to length. CS are continuous utility straps which can be cut to length on the job site. Packaged in lightweight (about 40 pounds) cartons.
FINISH: Galvanized. Some products available in ZMAX® coating; see Corrosion Information, page xx-xx.
INSTALLATION: • Use all specified fasteners. See General Notes.

- Wood shrinkage after strap installation across horizontal wood members may cause strap to buckle outward.
- Refer to the applicable code for minimum nail penetration and minimum wood edge and end distances.
- The table shows the maximum allowable loads and the nails required to obtain them. Fewer nails may be used; reduce the allowable load as shown in footnote #3.
- The cut length of the strap shall be equal to twice the “End Length” noted in the table plus the clear span dimension.
- CMST only—Use every other round hole if the wood tends to split. Use round and triangle holes for comparable MST loads, providing wood does not tend to split.
- For lap splice and alternate nailing information, refer to technical bulletin T-CMST.
- CS straps are available in 25' lengths, order CS14-R, CS16-R, CS18-R, CS20-R or CS22-R.

CODES: See page 12 for Code Reference Key Chart.

These products are available with additional corrosion protection. Additional products on this page may also be available with this option, check with Simpson Strong-Tie for details.

These products are approved for installation with the Strong-Drive® SD Connector screw. See page 27 for more information.

Model No.	Total L	Ga	DF/SP		SPF/HF		Allowable Tension Loads (160)	Code Ref.
			Fasteners	End Length	Fasteners	End Length		
CMST12	40'	12	74 - 16d	33"	84 - 16d	38"	9215	I4, L3, F2
			86 - 10d	39"	98 - 10d	44"	9215	
CMST14	52½'	14	56 - 16d	26"	66 - 16d	30"	6490	
			66 - 10d	30"	76 - 10d	34"	6490	
CMSTC16	54'	16	50 - 16d sinker	20"	58 - 16d sinker	25"	4585	
CS14	100'	14	26 - 10d	15"	30 - 10d	16"	2490	
			30 - 8d	16"	36 - 8d	19"	2490	
CS16	150'	16	20-10d	11"	22 - 10d	13"	1705	
			22 - 8d	13"	26 - 8d	14"	1705	
CS18	200'	18	16 - 10d	9"	18 - 10d	11"	1370	
			18 - 8d	11"	22 - 8d	12"	1370	
CS20	250'	20	12 - 10d	6"	14 - 10d	9"	1030	
			14 - 8d	9"	16 - 8d	9"	1030	
CS22	300'	22	10 - 10d	7"	12 - 10d	7"	845	
			12 - 8d	7"	14 - 8d	8"	845	

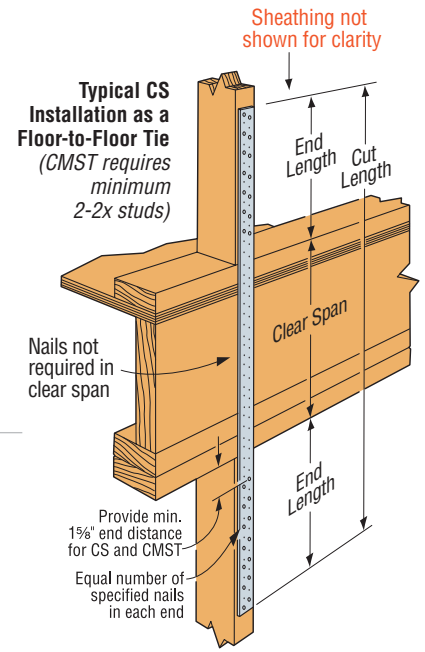

CS16 Hole Pattern
(all other CS straps similar)

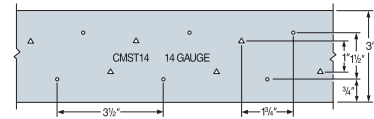

CMST14 Hole Pattern
(CMST12 similar)

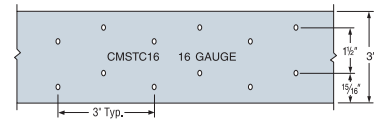

CMSTC16 Hole Pattern

Gauge stamped on part for easy identification

1. Fastener quantities and end lengths are calculated using an increase for wind or seismic loading.
2. Use half of the required nails in each member being connected to achieve the listed loads.
3. Calculate the connector value for a reduced number of nails as follows: Allowable Load = $\frac{\text{No. of Nails Used}}{\text{No. of Nails in Table}} \times \text{Table Load}$
 Example: CMSTC16 in DF/SP with 40 nails total.
 (Half of the nails in each member being connected) Allowable Load = $\frac{40 \text{ Nails (Used)}}{50 \text{ Nails (Table)}} \times 4585 \text{ lbs} = 3668 \text{ lbs}$
4. Tension loads apply for uplift when installed vertically.
5. **NAILS:** 16d = 0.162" dia. x 3 1/2" long,
 16d Sinker = 0.148" dia. x 3 1/4" long, 10d = 0.148" dia. x 3" long.
 See pages 22-23 for other nail sizes and information.

NOT SURE HOW MUCH COIL STRAP YOU NEED?
 Simpson Strong-Tie has a web-based app, the Coil Strap Length Calculator, which can help you quickly determine the cut length of each strap and the total amount of coil strap needed for each application on a project.
 For more information or to access, go to www.strongtie.com/software.

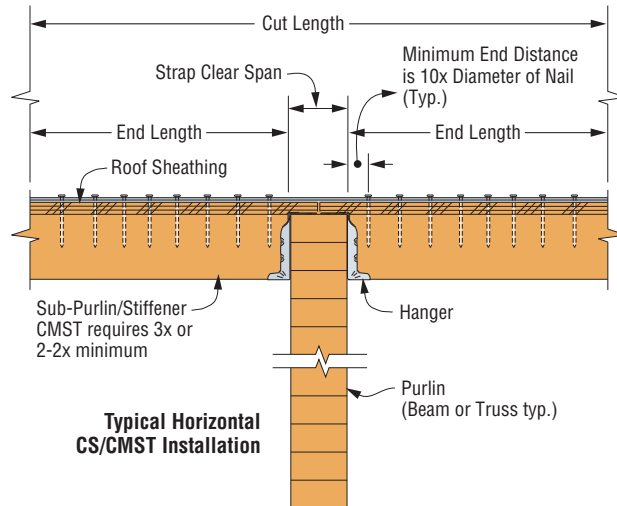

Typical Horizontal CS/CMST Installation

TS Twist Straps

Twist straps provide a tension connection between two wood members. An equal number of right and left hand units are supplied in each carton.

MATERIAL: 16 gauge.

FINISH: Galvanized. See Corrosion Information, pages 13-15.

INSTALLATION: • Use all specified fasteners. See General Notes.

- TS should be installed in pairs to reduce eccentricity.

CODES: See page 12 for Code Reference Key Chart.

Model No.	L	Fasteners (Total)	Allowable Loads (160)	Code Ref.
TS9	9	8-16d	530	170
TS12	11%	10-16d	665	
TS18	17%	14-16d	930	
TS22	21%	18-16d	1215	

1. Install half of the fasteners on each end of the strap to achieve full loads.
2. Loads have been increased 60% for wind or earthquake loading with no further increase allowed; reduce where other loads govern.
3. 16d sinkers (0.148" dia. x 3 3/4") may be substituted for the specified 16d commons at 0.84 of the table loads.
4. Loads are for a single TS.
5. **NAILS:** 16d = 0.162" dia. x 3 1/2" long, See pages 22-23 for other nail sizes and information.

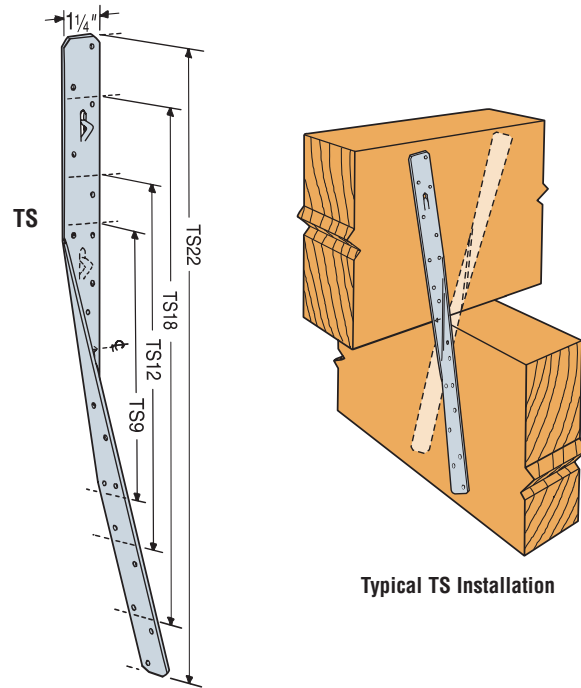

SA Strap Connectors

A seismic tie for horizontal ties across intervening members.

FINISH: Galvanized

INSTALLATION:

- Use all specified fasteners. See General Notes.
- May not be suitable for floor diaphragms which protrude above beams.
- SA36 can be field-bent for other intermediate beam widths.

CODES: See page 12 for Code Reference Key Chart.

Model No.	Strap Section	L	Fasteners (Total)			Allowable Horizontal Loads		Code Ref.
			Nails	Bolts		Nails (160)	Bolts (160)	
				Qty.	Dia.			
SA36	12 ga x 2 1/16	36	22-16d	4	1/2	1900	1900	I15, L7

1. Allowable loads have been increased 60% for wind or earthquake loading with no further increase allowed; reduce where other loads govern.
2. Allowable loads assume a restrained member of 3 1/2" min. thickness with bolts in single shear.
3. Bolt and nail values may not be combined.
4. **NAILS:** 16d = 0.162" dia. x 3 1/2" long, See pages 22-23 for other nail sizes and information.

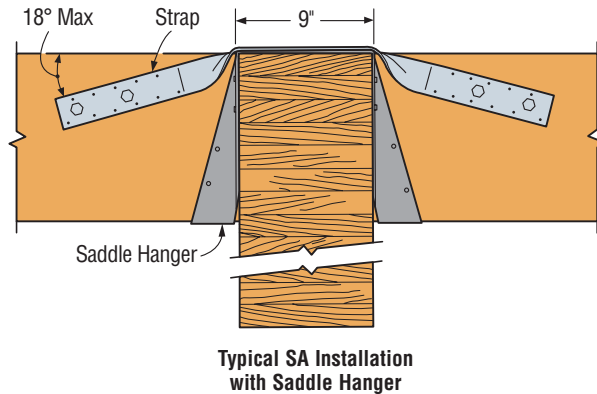

STRONG-DRIVE® SDWF FLOOR-TO-FLOOR Screw

The Simpson Strong-Tie® Strong-Drive® SDWF Floor-to-Floor screw is designed to simplify the floor-to-floor, wind-uplift restraint connection while providing superior performance over the life of the structure. The unique design of the Strong-Drive SDWF Floor-to-Floor screw enables it to attach upper and lower walls together from the top, spanning the floor system and providing an easy-to-install connection within the continuous uplift load path of the structure.

The innovative TUV take-up washer plays a key role in the long-term performance of the Strong-Drive SDWF Floor-to-Floor screw when installed between the screw and the sole plate of the upper floor. As the structure settles because of shrinkage and construction loading, the threaded portion under the head of the screw ratchets up through the tabs of the TUV, which is fastened with Strong-Drive SD Connector screws. The interlock between the tabs of the take-up washer and the threads under the head of the Strong-Drive SDWF Floor-to-Floor screw prevent the screw from sliding back under load, providing a simple yet reliable means of shrinkage compensation up to 3/4" per story.

MATERIAL: SDWF – carbon steel, TUV – 10 gauge

FINISH: SDWF—E-Coat™; TUV—Galvanized

INSTALLATION: • Use all specified fasteners. See General Notes.

- Refer to flier F-SDWFTUV, or the [Simpson Strong-Tie Fastening Systems catalog](#) or visit www.strongtie.com.

KIT CONTAINS: 25—Strong-Drive SDWF Floor-to-Floor screws,
25—TUV take-up washers, 100—#9x2½ Strong-Drive SD Connector screws, 3/16" hex driver bit and screw depth guide.

CODES: See page 12 for Code Reference Key Chart.

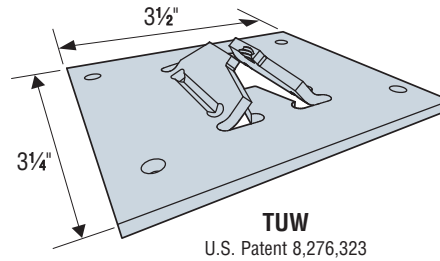

TUV
U.S. Patent 8,276,323

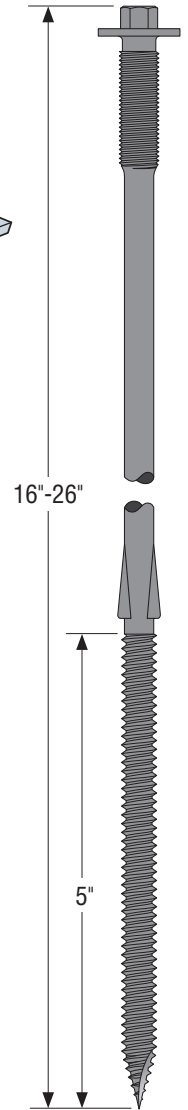

Strong-Drive® SDWF
U.S. Patent 8,276,323

Product Information and Withdrawal Loads

Model No	Size (in.)	Thread Length (in.)	Allowable Joist Depth Below (in.)				Allowable Withdrawal per Thread Penetration (lbs./in.) (100)			Code Ref.
			Single Bottom Plate		Double Bottom Plate		SP	DF	SPF	
			Min.	Max.	Min.	Max.				
SDWF2716-TUV	0.27 x 16	5	8½	10½	6¾	9	295	250	180	I24, I26, F31, L24
SDWF2720-TUV	0.27 x 20	5	12½	14½	10¾	13				
SDWF2724-TUV	0.27 x 24	5	16½	18½	14¾	17				
SDWF2726-TUV	0.27 x 26	5	18½	20½	16¾	19				

1. Allowable loads may be increased for load duration up to $C_D = 1.6$.
2. Joist depth listed based on the 3/4" subfloor and 3" of thread penetration into double top plates.

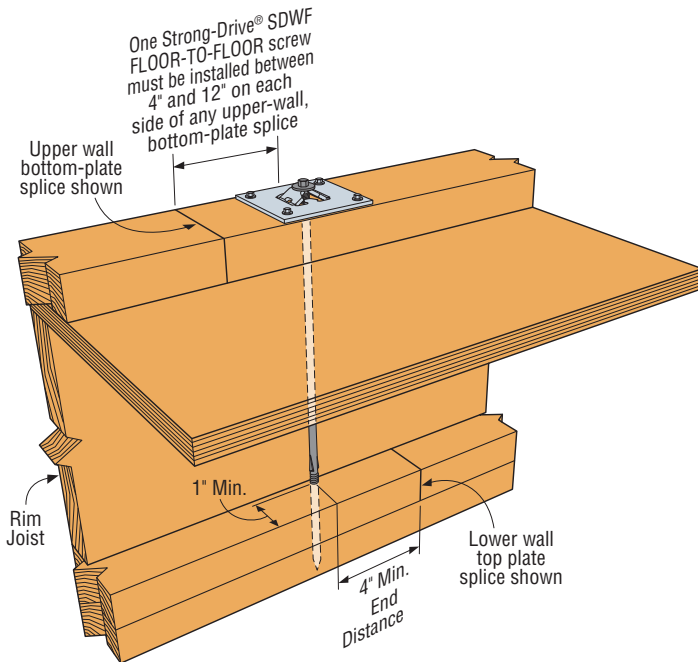

Typical Strong-Drive® SDWF FLOOR-TO-FLOOR and TUV Installation

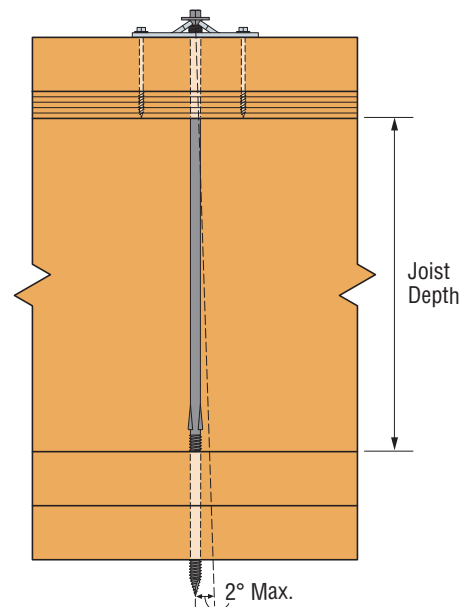

Typical Strong-Drive® SDWF FLOOR-TO-FLOOR Angle Limit Installation

STRONG-DRIVE® SDWF FLOOR-TO-FLOOR Screw

Uniform Uplift Loads

Maximum Strong-Drive SDWF FLOOR-TO-FLOOR Screw Spacing (in.) Along Wall Bottom Plate for Wind Uplift											
Bottom Plate	Interstory Unit Wind Uplift Lbs. Per Lineal Foot (plf)										
Single 2x4	100 plf	150 plf	200 plf	250 plf	300 plf	350 plf	400 plf	450 plf	500 plf	550 plf	600 plf
SP	46	40	36	34	30	28	26	24	24	22	22
DF	48	42	38	34	32	30	30	26	24	22	20
SPF	46	40	36	34	32	30	26	22	20	18	16
Single 2x6	100 plf	150 plf	200 plf	250 plf	300 plf	350 plf	400 plf	450 plf	500 plf	550 plf	600 plf
SP	56	48	44	40	38	36	34	34	32	30	28
DF	56	48	44	40	38	34	30	26	24	22	20
SPF	52	46	42	38	34	30	26	22	20	18	16

1. Spacing listed based on lesser of: single bottom plate bending allowable load, single bottom plate deflection limited to spacing/240 and ¼" max, screw allowable withdrawal load, and take-up washer allowable load.
2. Withdrawal load is based on a $C_D = 1.6$ and minimum 3" penetration into lower wall double top plates.
3. Stud-to-plate connections are required to complete the load path. These connections shall not exceed the lesser of 48" o.c. or Strong-Drive SDWF Floor-To-Floor spacing.
4. Spacing values listed for SP lumber consider new base values adopted by AWC on June 1, 2013.

Concentrated Uplift Loads

Model No	Single Strong-Drive SDWF-TUW				Double Strong-Drive SDWF-TUW			
	Allowable Tension Load (160)			Deflection at Highest Allowable Load (in.)	Allowable Tension Load (160)			Deflection at Highest Allowable Load (in.)
	SP	DF	SPF		SP	DF	SPF	
SDWF2716-TUW	1410	1200	865	0.095	2270	2125	1730	0.142
SDWF2720-TUW								
SDWF2724-TUW								
SDWF2726-TUW								

1. Allowable loads listed include a wood load duration factor of $C_D = 1.6$ for wind or earthquake loading with no further increase allowed.
2. Single and double Strong-Drive SDWF-TUW applications listed are for concentrated load uplift restraint conditions (i.e. end of header, at girders, or at the end of shearwalls).

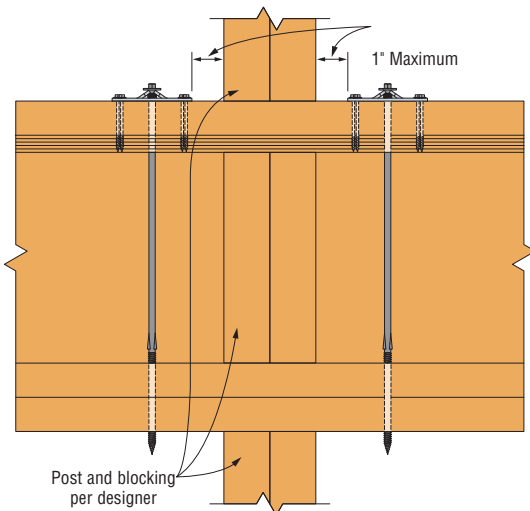

Double Strong-Drive SDWF-TUW Concentrated Load Restraint Detail at Continuous Wall
(Single Strong-Drive SDWF-TUW similar)

Note: Stud-to-plate connections are required to complete the load path and are the responsibility of the Designer.

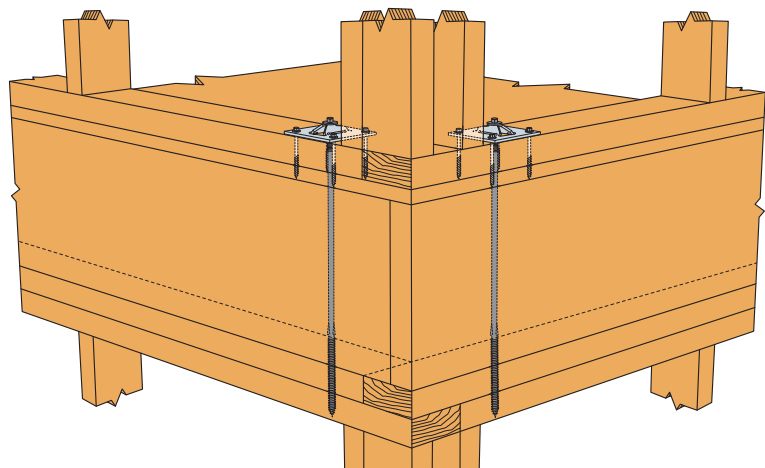

Perspective View of Corner Conditions with Double Strong-Drive SDWF-TUW
(Single Strong-Drive SDWF-TUW similar)

FSC Floor Span Connector

As an alternative to coil strap, our new FSC-Floor Span Connector connects upper floors to lower floors from the inside of the wall. The convenient obround holes make installation in narrow wall cavities easy. Installs with a 3/8" all thread rod, nut and washer (not included).

MATERIAL: See table

FINISH: Galvanized

INSTALLATION:

- Can be used on a single 2x stud.
- Threaded rod, washers and nuts are not supplied with the FSC.
- Use 3/8" threaded rod grade A307 or better, with matching nuts and cut washers.
- FSC may be installed a maximum of 18" from the sill or top plates.
- Drill 1/2" to 3/4" diameter hole through the plates for threaded rod access, hole should be located approximately 1 1/2" away from the face of stud used for FSC attachment.
- Nails can be installed up to 30 degree angle with no reduction in load capacity.

CODES: See page 12 for Code Reference Key Chart.

Model No.	Ga	Fasteners		Allowable Tension Load		Code Ref.
		Stud	Anchor	DF/SP (160)	SPF/HF (160)	
FSC	12	15-10dx1 1/2"	3/8" ATR	1830	1570	IP1, L18, F25

1. The allowable loads have been increased for wind or earthquake loading with no further increase allowed. Reduce where other loads govern.
2. Load values are based on a minimum lumber thickness of 1 1/2".
3. Standard cut washer is required with the 3/8" all thread rod.
4. The FSC can be used on offset studs provided the horizontal offset is no greater than 3". Refer to flier F-FSC for more information.
5. **NAILS:** 10dx1 1/2" = 0.148" dia. x 1 1/2" long.
See pages 22-23 for other nail sizes and information.

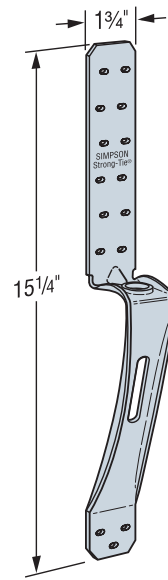

FSC
Patent Pending

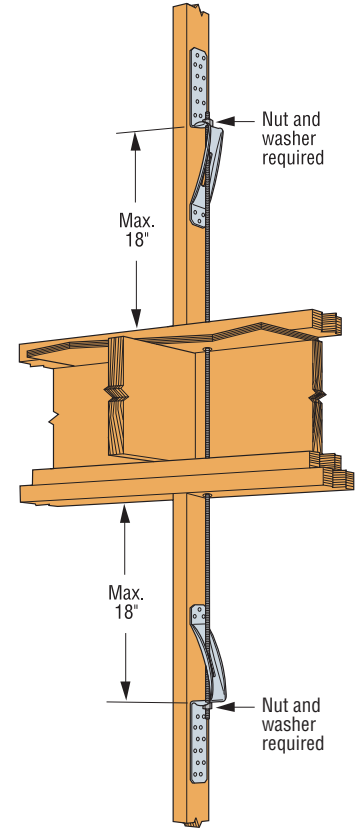

Typical FSC Installation

MSTC48B3/MSTC66B3 Pre-Bent Straps

The MSTC48B3 and MSTC66B3 are pre-bent straps designed to transfer tension load from an upper story shearwall to a beam on the story below.

MATERIAL: 14 gauge

FINISH: Galvanized. Contact Simpson Strong-Tie.

CODES: See page 12 for Code Reference Key Chart.

These products are available with additional corrosion protection. Additional products on this page may also be available with this option, check with Simpson Strong-Tie for details.

Model No.	Min. Wood Beam Dim.		Fasteners			Allowable Tension Loads		Code Ref.
	Width (min)	Depth (min)	Beam		Studs/Post	DF/SP (160)	SPF/HF (160)	
			Face	Bottom				
MSTC48B3	3	9/4"	12-10d	4-10d	38-10d	3975	3420	14, F26
MSTC66B3	3 1/2"	11 1/4"	14-10d	4-10d	38-10d	4505	3875	

1. Using fewer than 38 nails in the studs/post will reduce the capacity of the connection. To calculate a reduced capacity use 199 lbs. per nail for DF/SP or 172 lbs. per nail for HF/SPF. Minimum length of extent of reduced nails may not be less than a 21" as is shown in graphic.
2. Nails in studs/post shall be installed symmetrically. Nails may be installed over the entire length of the strap over the studs/post.
3. The minimum 3" wide beam may be made up by double 2x members.
4. MSTC48B3 and MSTC66B3 installed over wood structural panel sheathing up to 1/2" thick achieve 0.85 of table loads.
5. PSL beam may be used in lieu of standard dimension lumber beam with no load reductions.
6. Multiply allowable loads by 1.85 to attain an allowable load for installations where two straps have been installed with a 1 1/2" clear space between straps.
7. Structural composite lumber columns have sides that either show the wide face or the edges of the lumber strands/veneers known as the narrow face. Values in the tables reflect installation into the wide face. See Technical Bulletin T-C-SCLCLM for load reductions due to narrow face installations.
8. **NAILS:** 10d = 0.148" dia. x 3" long. See pages 22-23 for other nail sizes and information.

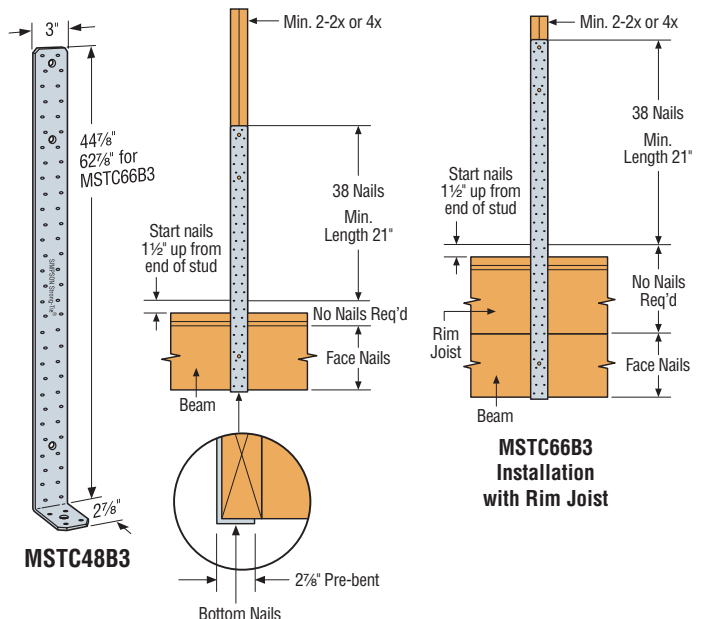

MSTC48B3

MSTC48B3
Installation with no Rim Joist

MSTC66B3
Installation with Rim Joist

FTA/LFTA Floor Tie Anchors

Designed for use as a floor-to-floor tension tie, one FTA replaces two comparably sized holdowns and the threaded rod.

The LFTA Light Floor Tie Anchor is for nailed installations.

MATERIAL: See table

FINISH: LFTA—galvanized;

FTA—Simpson Strong-Tie® gray paint

INSTALLATION: • Use all specified fasteners. See General Notes.

- Washers required on side opposite FTA for full loads.
- Nail holes between floors allow preattachment to the joist during installation; these nails are not required.

OPTIONS:

- The standard model's clear span of 17" will accommodate up to a 12" joist. The clear span of the FTA may be increased with a corresponding increase in overall length.

CODES: See page 12 for Code Reference Key Chart.

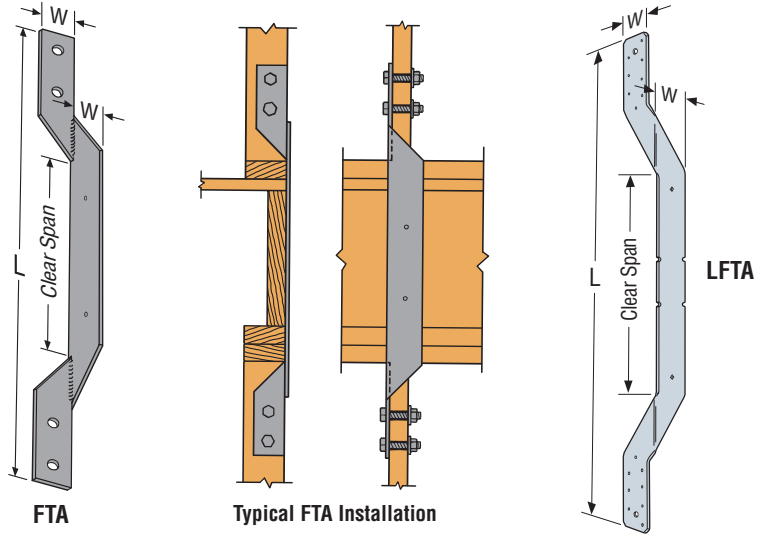

Model No.	Ga	Dimensions			Fasteners (Total)		Allowable Uplift Loads ¹ (160)					Code Ref.	
		W	Clear Span	L	Qty	Dia	Vertical Member Thickness						
							1½	2	2½	3	3½		LFTA ²
LFTA	16	2¼	17	38½	16-10d	—	—	—	—	—	—	1205	I17, L6, F16
FTA2	10	3	17	37½	4	⅝	1890	2515	3120	3385	3385	—	
FTA5	10	3½	17	45½	4	¾	2240	3000	3750	4400	4400	—	
FTA7	3	3½	17	56	6	⅞	3715	5020	6210	7600	7600	—	

1. Allowable loads have been increased for wind or earthquake loading with no further increase allowed. Reduce where other loads govern.
2. Reduce the allowable load for the LFTA according to the code when nails penetrate wood less than 1¼".
3. **NAILS:** 10d = 0.148" dia. x 3" long. See pages 22-23 for other nail sizes and information.

T and L Strap Ties

T and L Strap Ties are versatile utility straps. See Architectural Products Group for aesthetically pleasing options with black powder-coated paint.

FINISH: Galvanized. See Corrosion Information, pages 13-15.

CODES: See page 12 for Code Listing Key Chart.

Model No.	Ga	Dimensions			Fasteners			Code Ref.
		L	H	W	Nails	Bolts		
						Qty	Dia	
55L	16	4¾	4¾	1¼	5-10d	—	—	180
66L	14	6	6	1½	10-16d	3	⅜	
88L	14	8	8	2	12-16d	3	½	
1212L	14	12	12	2	14-16d	3	½	
66T	14	6	5	1½	8-16d	3	⅜	
128T	14	12	8	2	12-16d	3	½	
1212T	14	12	12	2	12-16d	3	½	

1. These connectors are not load-rated.
2. **NAILS:** 16d = 0.162" dia. x 3½" long, 10d = 0.148" dia. x 3" long. See pages 22-23 for other nail sizes and information.

These products are available with additional corrosion protection. Additional products on this page may also be available with this option, check with Simpson Strong-Tie for details.

Model No.	Ga	Dimensions			Minimum Bolt End & Edge Distances		Bolts		Allowable Loads ^{1,2}		Code Ref.
		W	H	L	d ₁	d ₂	Qty	Dia	Tension/Uplift	F ₁	
									(100/160)	(100/160)	
1212HL	7	2½	12	12	2½	4¾	5	⅝	1535	565	170
1616HL	7	2½	16	16	2½	4¾	5	⅝	1535	565	
1212HT	7	2½	12	12	2½	4¾	6	⅝	2585	815	
1616HT	7	2½	16	16	2½	4¾	6	⅝	2585	815	

1. 1212HL, 1616HL, 1212HT and 1616HT are to be installed in pairs with machine bolts in double shear. A single part with machine bolts in single shear is not load-rated.
2. Allowable loads are based on a minimum member thickness of 3½".
3. 1212HT, 1616HT loads assume a continuous beam.

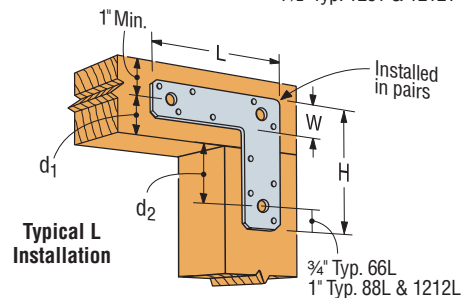
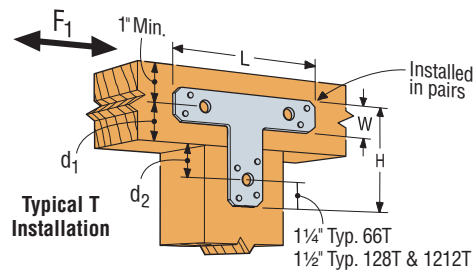
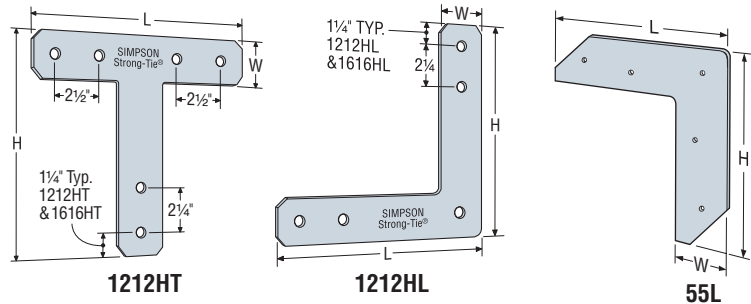

PCT Purlin Cross Ties

Designed using a section that works in both tension and compression.

MATERIAL: 1½" square tube steel
ASTM A500 Grade B

FINISH: Simpson Strong-Tie® gray paint
INSTALLATION: • Use all specified fasteners.
See General Notes.

- PCT18 and 23 are sized to span a maximum hanger seat depth ("B" dimension) of 4".
- PCT27 and 38 are sized to span a maximum hanger seat depth ("B" dimension) of 6".
- Tube section helps with drilling alignment, through the purlin.
- Offset angle to allow drilling access through glulam.
- 2½" or a 2⅞" diameter hole required for the PCT to pass through the carrying member.
- Install in pairs.

OPTIONS: Contact Simpson Strong-Tie for other lengths.

CODES: See page 12 for Code Reference Key Chart.

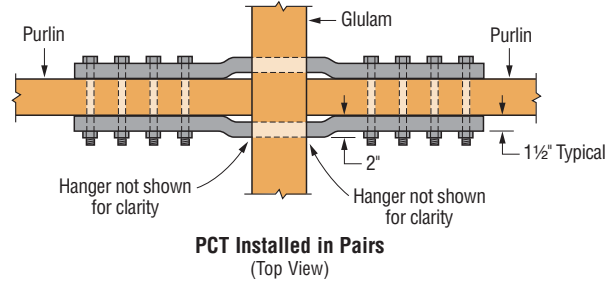
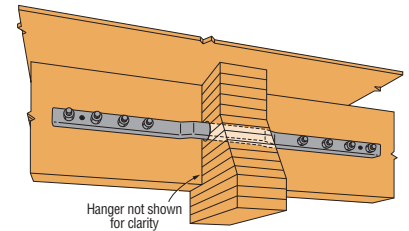
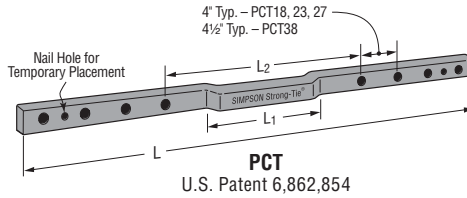

Model No.	Tube Thickness	Total Length L	L ₁	L ₂	No. and Size of Fasteners	Allowable Loads per Pair of PCTs					Code Ref.		
						Steel Tension	Steel Compression	Capacity Based on Double Shear Application and Length of Bolt in Purlin - DF/SP (160)					
								3⅞	3½	5⅞		5½	6¾
PCT18	⅝	44¾	14	17¾	8-⅝ MB	24665	19165	17235	19110	19110	19090	19050	115, L7
PCT23	⅝	52¾	14	17¾	10-⅝ MB	24665	19165	21390	23645	23645	23620	23525	
PCT27	⅜	66¾	19½	23½	12-⅝ MB	39665	28665	24855	27705	28400	28430	28255	
PCT38	⅜	71¾	19½	23½	12-¾ MB	39665	26030	29105	33020	40485	40570	40190	

1. Allowable loads have been increased 60% for wind or earthquake loading with no further increase allowed; reduce where other loads govern.
2. Install in pairs.
3. Minimum bolt length is (Purlin width + 3" (PCT) + 1" (nut)).
4. Bolt value assume minimum 10½" deep purlin.
5. Engineer of record is responsible for evaluating the glulam.

HCSTR Hinge Connector Straps

Use Hinge Connector Straps for retrofit applications to strap horizontal wood members together where a hinge connector interferes.

All bolt holes shall be ⅜" (minimum) and ⅝" (maximum) larger than the bolt diameter (2012 NDS 11.1.3.2).

MATERIAL: HCSTR2, HCSTR3—7 gauge; HCSTR4—3 gauge
FINISH: HCSTR4—Simpson Strong-Tie® gray paint.
All others—Galvanized

OPTIONS:

- Contact Simpson Strong-Tie for longer lengths.
For use with Simpson Strong-Tie hinge connectors.

CODES: See page 12 for Code Reference Key Chart.

These products are available with additional corrosion protection. Additional products on this page may also be available with this option, check with Simpson Strong-Tie for details.

Model No.	Fasteners (Total)		Allowable Loads (160)	Code Ref.
	Qty	Dia		
HCSTR2	4	⅜	9725	170
HCSTR3	6	⅜	14170	
HCSTR4	8	⅜	18770	

1. Allowable loads are for straps used in pairs and include a 60% increase for wind or earthquake loading with no further increase allowed; reduce where other loads govern.
2. Allowable loads assume a carrying member of 5⅞" minimum thickness with bolts in double shear.
3. Designed for HC style hinge connectors; contact Simpson Strong-Tie for lengths for HCA and HC3A (only) style hinge connectors.

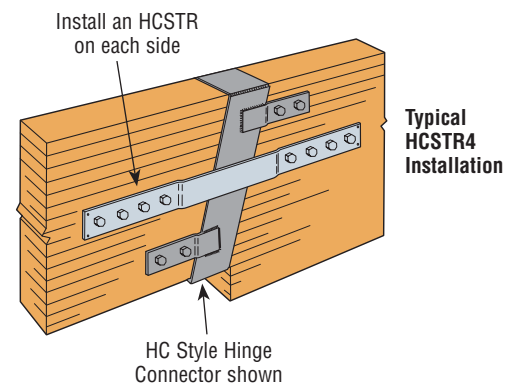
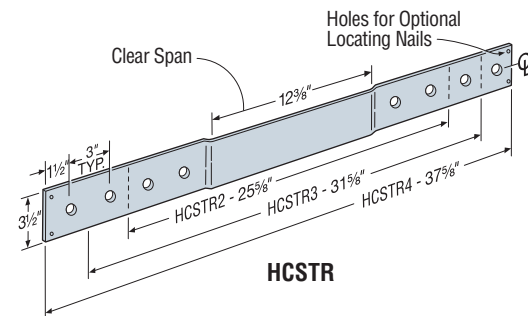

H/TSP Seismic & Hurricane Ties

Simpson Strong-Tie® hurricane ties provide a positive connection between truss/rafter and the wall of the structure to resist wind and seismic forces. New additions to the line provide even more options.

- H10AR – The heavy-duty design of the H10A available with a 2" wide throat to accommodate rough lumber
- H10A-2 – The H10A design with a 3" throat for double 2x members
- H2ASS, H2.5ASS and H10ASS – Popular ties now available in stainless steel.

MATERIAL: See table.

FINISH: Galvanized. H7Z and H11Z—ZMAX® coating. Some models available in stainless steel or ZMAX; see Corrosion Information, pages 13-15 or visit www.strongtie.com.

INSTALLATION: • Use all specified fasteners. See General Notes.

- H1 can be installed with flanges facing inward (*reverse of H1 installation drawing; number 1*).
- H2.5T, H3, H4, H5 and H6 ties are shipped in equal quantities of right and left versions (*right versions shown*).
- Hurricane ties do not replace solid blocking.
- When installing ties on plated trusses (*on the side opposite the truss plate*) do not fasten through the truss plate from behind. This can force the truss plate off of the truss and compromise truss performance.
- H10A optional nailing to connect shear blocking, use 8d nails. Slots allow maximum field bending up to a pitch of 6:12, use H10A sloped loads for field bent installation.

CODES: See page 12 for Code Reference Key Chart.

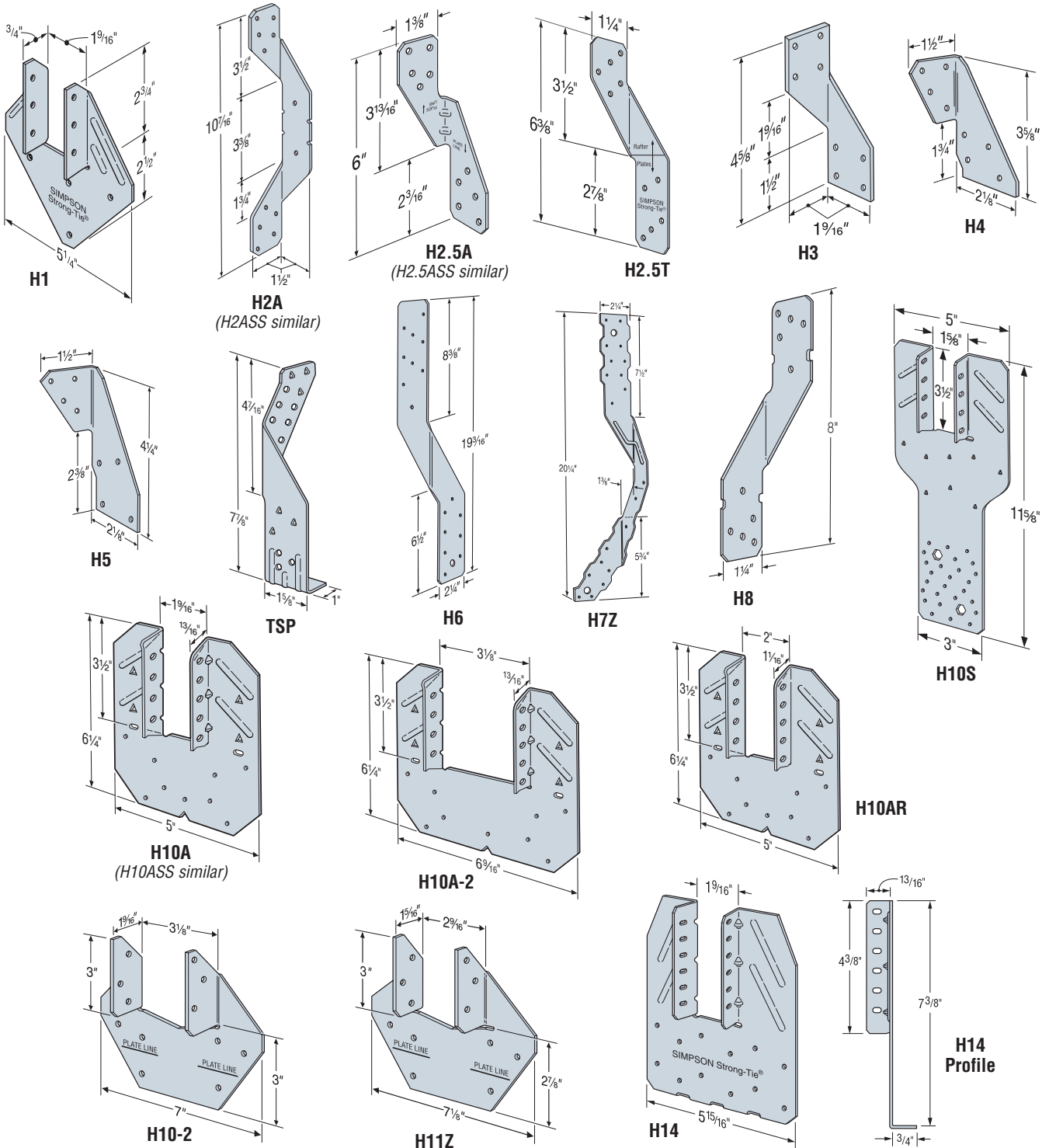

H/TSP Seismic & Hurricane Ties

These products are available with additional corrosion protection. Additional products on this page may also be available with this option, check with Simpson Strong-Tie for details.

These products are approved for installation with the Strong-Drive® SD Connector screw. See page 27 for more information.

Model No.	Ga	Fasteners			DF/SP Allowable Loads			Uplift with 8dx1½ Nails (160)	SPF/HF Allowable Loads			Uplift with 8dx1½ Nails (160)	Code Ref.
		To Rafters/Truss	To Plates	To Studs	Uplift (160)	Lateral (160) F ₁	Lateral (160) F ₂		Uplift (160)	Lateral (160) F ₁	Lateral (160) F ₂		
H1	18	6-8dx1½	4-8d	—	585	485	165	455	400	415	140	370	I17, L5, L6, F16
H2A	18	5-8dx1½	2-8dx1½	5-8dx1½	575	130	55	—	495	130	55	—	IP1, L18, F25
H2ASS	18	5-SS8D	2-SS8D	5-SS8D	400	130	55	400	345	130	55	345	170
H2.5A	18	5-8d	5-8d	—	600	110	110	575	535	110	110	495	I17, L5, L6, F16
H2.5ASS	18	5-SS8d	5-SS8d	—	440	75	70	365	380	75	70	310	170
H2.5T	18	5-8d	5-8d	—	545	135	145	425	545	135	145	425	IP1, L18, F25
H3	18	4-8d	4-8d	—	455	125	160	415	320	105	140	290	I17, L6, F16
H4	20	4-8d	4-8d	—	360	165	160	360	235	140	135	235	I17, L5, L6, F16
H5	18	4-8d	4-8d	—	455	115	200	455	265	100	170	265	I17, L5, L6, F16
H6	16	—	8-8d	8-8d	950	—	—	—	820	—	—	—	I17, F16
H7Z	16	4-8d	2-8dx1½	8-8d	985	400	—	—	845	345	—	—	I17, F16
H8	18	5-10dx1½	5-10dx1½	—	745	75	—	630	565	75	—	510	L5, L10, L18, F26
H10A Sloped	18	9-10dx1½	9-10dx1½	—	855	590	285	—	760	505	285	—	I17, L5, L18, F25
H10A	18	9-10dx1½	9-10dx1½	—	1140 ⁷	590	285	—	1015	505	285	—	I17, L5, L18, F25
H10ASS	18	9-SSN10	9-SSN10	—	970	565	170	—	835	485	170	—	170
H10AR	18	9-10dx1½	9-10dx1½	—	1050	490	285	—	905	420	285	—	170
H10S ^{9,10}	18	8-8dx1½	8-8dx1½ ¹⁰	8-8d	1010	660	215	550	870	570	185	475	IP1, L18, F25
H10A-2	18	9-10dx1½	9-10dx1½	—	1245	815	260	—	1070	700	225	—	L18, F25
H10-2	18	6-10d	6-10d	—	760	455	395	—	655	390	340	—	I17, L6, F16
H11Z	18	6-16dx2½	6-16dx2½	—	830	525	760	—	715	450	655	—	170
H14	18	1 12-8dx1½	13-8d	—	1350 ⁷	515	265	—	1050	480	245	—	IP1, L18, F25
		2 12-8dx1½	15-8d	—	1350 ⁷	515	265	—	1050	480	245	—	
TSP	16	9-10dx1½	6-10dx1½	—	740	310	190	—	635	265	160	—	F26
		9-10dx1½	6-10d	—	890	310	190	—	765	265	160	—	

1. Loads have been increased for wind or earthquake loading with no further increase allowed; reduce where other loads govern.
2. Allowable loads are for one anchor. A minimum rafter thickness of 2½" must be used when framing anchors are used on each side of the joist and on the same side of the plate (exception: connectors installed such that nails on opposite side don't interfere).
3. Allowable DF/SP uplift load for stud to bottom plate installation (see detail 15) is 390 lbs. (H2.5A); 265 lbs. (H2.5ASS); 360 lbs. (H4) and 310 lbs. (H8). For SPF/HF values multiply these values by 0.86.
4. Allowable loads in the F₁ direction are not intended to replace diaphragm boundary members or cross grain bending of the truss or rafter members.
5. When cross-grain bending or cross-grain tension cannot be avoided in the members, mechanical reinforcement to resist such forces may be considered.
6. Hurricane Ties are shown on the outside of the wall for clarity and assume a minimum overhang of 3½". Installation on the inside of the wall is acceptable (see General Instructions for the Installer notes u on page 17). For uplift

- Continuous Load Path, connections in the same area (i.e. truss to plate connector and plate to stud connector) must be on the same side of the wall. See T-HTIECONPATH for more information.
7. Southern Pine allowable uplift loads for H10A = 1340 lbs. and for the H14 = 1465 lbs.
8. Refer to Simpson Strong-Tie® technical bulletin T-HTIEBEARING for allowable bearing enhancement loads.
9. H10S can have the stud offset a maximum of 1" from rafter (center to center) for a reduced uplift of 890 lbs. (DF/SP) and 765 lbs. (SPF).
10. H10S nails to plates are optional for uplift but required for lateral loads.
11. Some load values for the stainless-steel connectors shown here are lower than those for the carbon-steel versions. Ongoing test programs have shown this to also be the case with other stainless-steel connectors in the product line that are installed with nails. Visit www.strongtie.com/corrosion for updated information.
12. NAILS: 16dx2½ = 0.162" dia. x 2½" long, 10d = 0.148" dia. x 3" long, 10dx1½ = 0.148" dia. x 1½" long, 8d = 0.131" dia. x 2½" long, 8dx1½ = 0.131" dia. x 1½" long. See pages 22-23 for other nail sizes and information.
13. SCREWS: Strong-Drive® SD #9x1½" (model SD9112) = 0.131" dia. x 1½" long (for the models marked with the orange flag only). Full table loads apply.

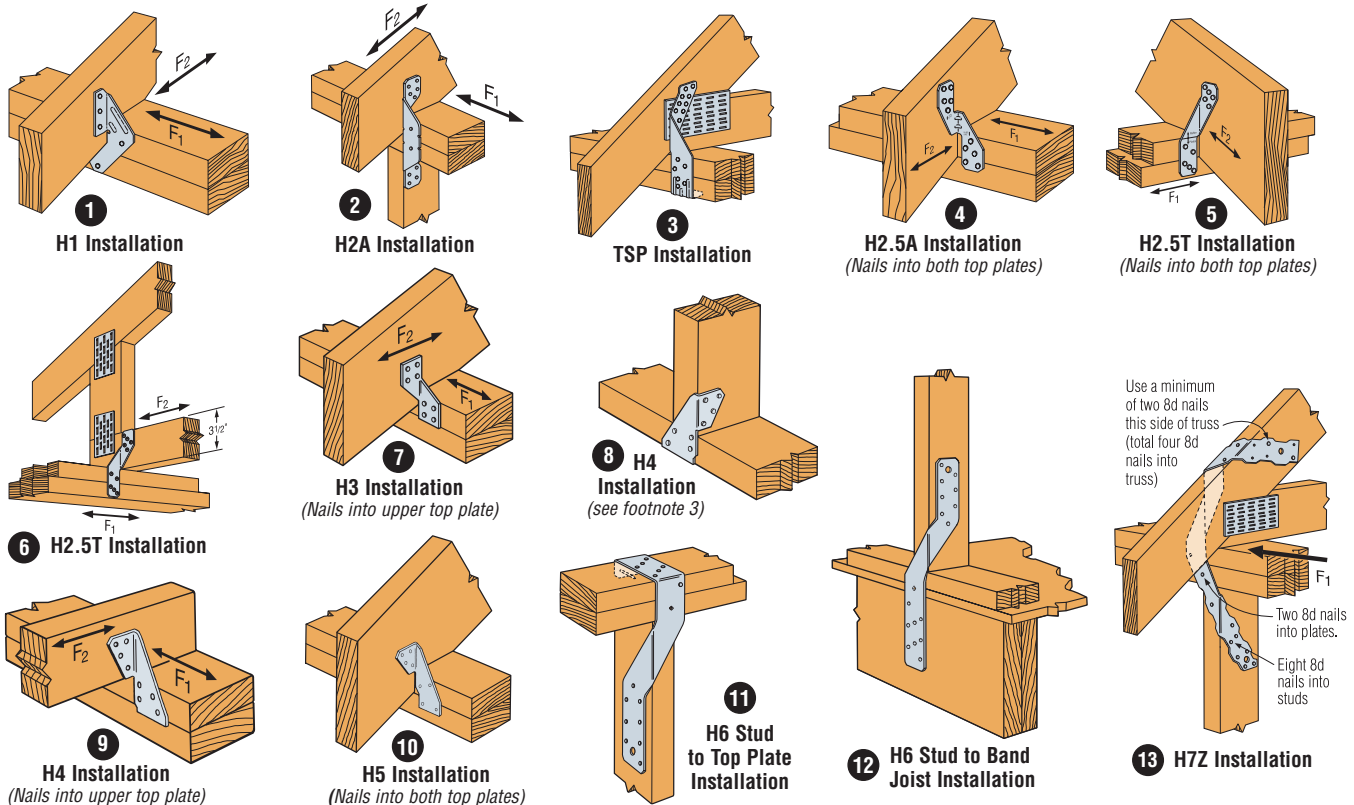

H/TSP Seismic & Hurricane Ties

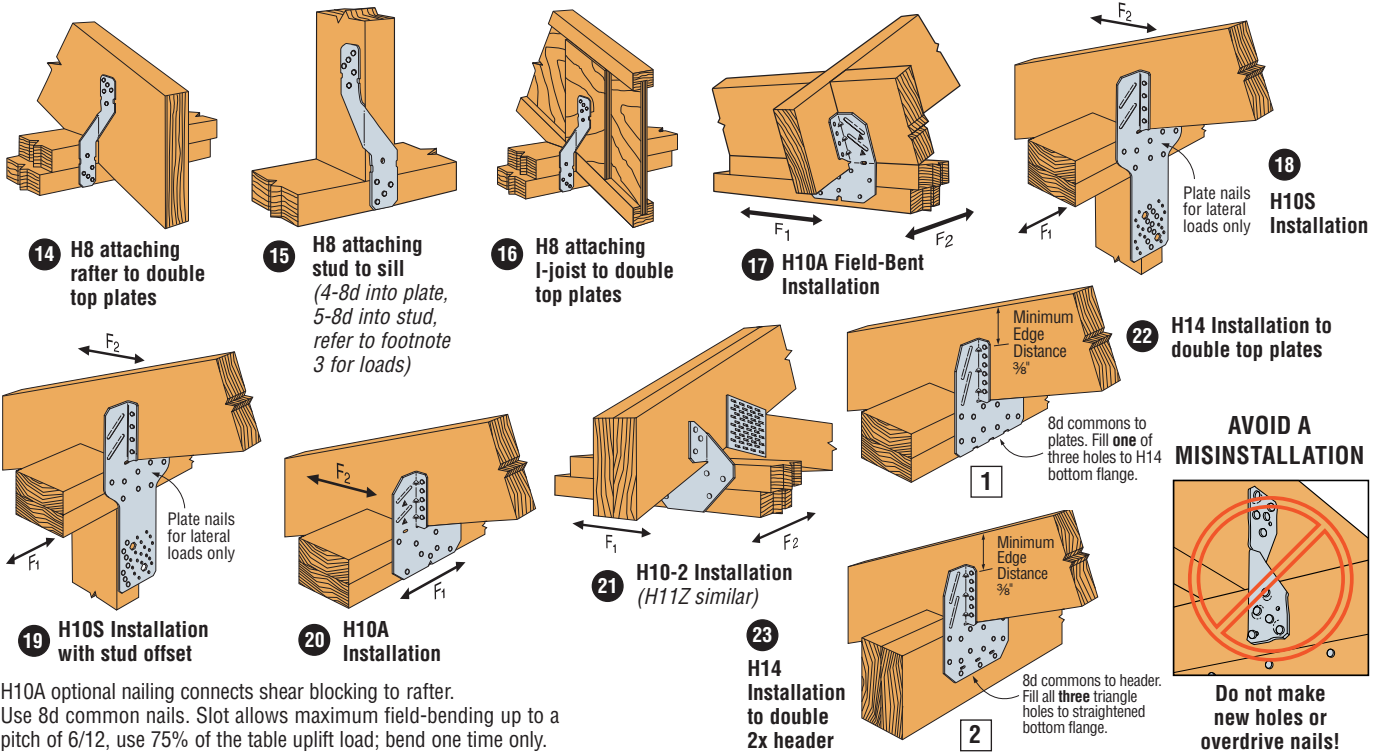

H10A optional nailing connects shear blocking to rafter. Use 8d common nails. Slot allows maximum field-bending up to a pitch of 6/12, use 75% of the table uplift load; bend one time only.

Considerations for Hurricane Tie Selection

1. What is the uplift load?
2. What is the parallel-to-plate load?
3. What is the perpendicular-to-plate load?
4. What is the species of wood used for the rafter and the top plates?
(Select the load table based on the lowest performing species of wood.)
5. Will the hurricane tie be nailed into both top plates or the upper top plate only?
6. What load or loads will the hurricane tie be taking?

When a connector is loaded simultaneously in more than one direction, the allowable load must be evaluated as shown here. For all connectors use the following equation:

$$\frac{\text{Design Uplift/Allowable Uplift} + \text{Design Lateral Parallel to Plate} / \text{Allowable Lateral Parallel to Plate} + \text{Design Lateral Perpendicular to Plate} / \text{Allowable Lateral Perpendicular to Plate}}{1.0} < 1.0$$

The three terms in the unity equation are due to the possible directions that exist to generate force on a connector. The number of terms that must be considered for simultaneous loading is at the sole discretion of the Designer and is dependent on their method of calculating wind forces and the utilization of the connector within the structural system.

As an alternate, certain roof to wall connectors (*embedded truss anchors, pages 180-181, seismic and hurricane ties, pages 196-198, and twist straps, pages 202-203*) can be evaluated using the following: The design load in each direction shall not exceed the published allowable load in that direction multiplied by 0.75.

7. Select hurricane tie based on performance, application, installed cost and ease of installation.

Hurricane Tie Installations to Achieve Twice the Load (Top View)

Both connectors shall be same model.

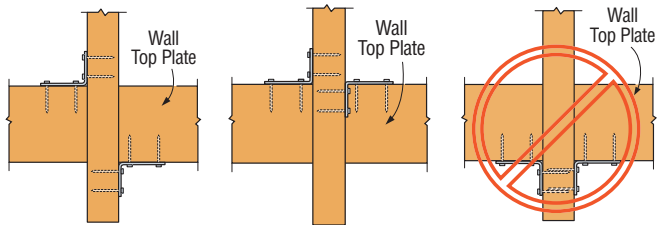

Install diagonally across from each other for minimum 2x truss.

Products can be on the same side of the wall provided they are configured as shown.

Nailing into both sides of a single ply 2x truss may cause the wood to split.

VB Knee Braces

The VB provides lateral resistance force at the bottom of beams when installed approximately 45° or more to the vertical plane.

MATERIAL: 12 gauge **FINISH:** Galvanized

INSTALLATION: • Use specified fasteners. See General Notes.

• 16-N54A fasteners are included with the brace.

CODES: See page 12 for Code Reference Key Chart.

Model No.	H (Beam Depth)	L	Fasteners (Total)	Allowable Tension Loads ¹		Code Ref.
				Floor (100)	Roof (125)	
VB5	10" - 15"	5'	16-N54A	990	1240	I15, L7
VB7	15" - 22½"	7'	16-N54A	990	1240	
VB8	22½" - 28½"	8'	16-N54A	990	1240	
VB10	28½" - 36"	10'	16-N54A	990	1240	
VB12	36" - 42"	12'	16-N54A	990	1240	

1. Roof loads have been increased 25% with no further increase allowed.

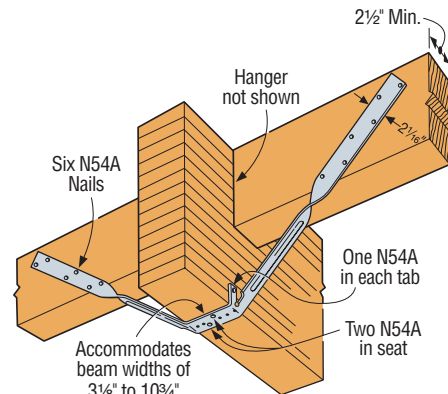

Typical VB Installation

STRONG-DRIVE® SDWC TRUSS Screws

The Strong-Drive SDWC Truss Screw is tested in accordance with ICC-ES AC233 (*screw*) and AC13 (*wall assembly and roof-to-wall assembly*) for uplift and lateral loads between wall plates and vertical wall framing and between the top plate and the roof rafters or trusses. Strong-Drive SDWC15450 is recognized for use in chemically treated wood as described in the evaluation report.

MATERIAL: Carbon steel

FINISH: SDWC15450—E-Coat™; SDWC15600—Clear Zinc Coating (with Orange Topcoat)

INSTALLATION: • See General Notes.

CODES: IAPMO-UES ER-262

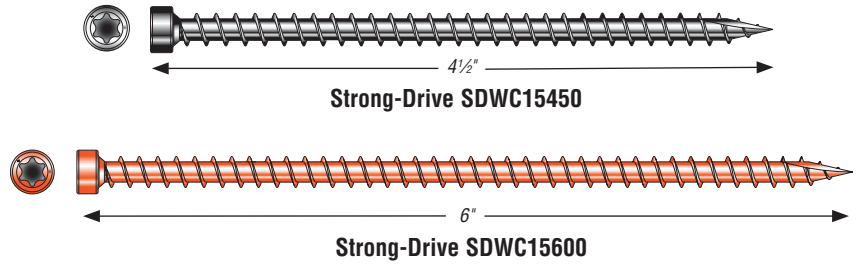

Strong-Drive® SDWC TRUSS Screw Allowable Roof-to-Wall Connection Loads – DFL, SP, SPF, HF¹⁻⁸

Model No.	Minor Diameter (in.)	Length (in.)	Thread Length (in.)	Allowable Loads						Code Ref.
				DF/SP			SPF/HF			
				Uplift	F ₁	F ₂	Uplift	F ₁	F ₂	
SDWC15600	0.152	6	5 3/4	615	130	225	485	115	192	IP5, F14

1. Loads have been increased for wind and earthquake ($C_D = 1.6$); no further increases allowed. Reduce when other loads govern.
2. Allowable loads are for an Strong-Drive SDWC Truss screw installed per the 'Recommended' or 'Optional' installation instructions. The Strong-Drive SDWC Truss screw is to be installed through a double 2x top plate into a minimum 2x4 truss or rafter.
3. An Strong-Drive SDWC Truss screw may be used in each ply of 2- or 3-ply rafters or trusses. The allowable uplift load for each screw shall be multiplied by 0.90, but may be limited by the capacity of the plate or the connection between the top plate to the framing below. Strong-Drive SDWC Truss screws in multi-ply assemblies must be spaced a minimum of 1 1/2" o.c.
4. Screws are shown installed on the interior side of the wall. Installations on the exterior side of the wall are acceptable when the rafter or truss overhangs the top plates a minimum of 3 1/2".
5. For Uplift Continuous Load Path, top plate to stud connectors such as the H2.5A, TSP or MTS12 must be located on the same side of the wall as the screw.
6. When the screw is loaded simultaneously in more than one direction, the allowable load must be evaluated using the following unity equation: $(\text{Design Uplift} \div \text{Allowable Uplift}) + (\text{Design } F_1 \div \text{Allowable } F_1) + (\text{Design } F_2 \div \text{Allowable } F_2) \leq 1.0$.
7. Table loads do not apply to trusses with end-grain bearing.
8. Top plate, stud and top plate splice fastened per applicable Building Code.

Typical Roof-to-Wall Connection

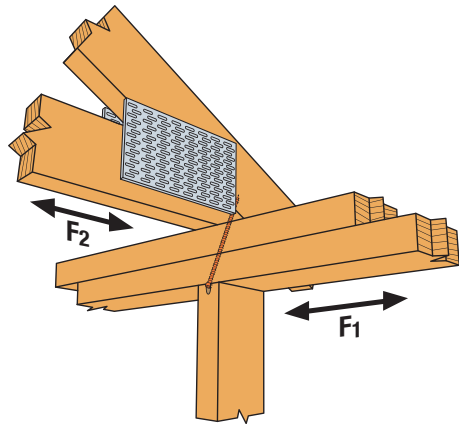

Typical Strong-Drive® SDWC Installation – Truss Aligned with Stud
(Offset truss similar)

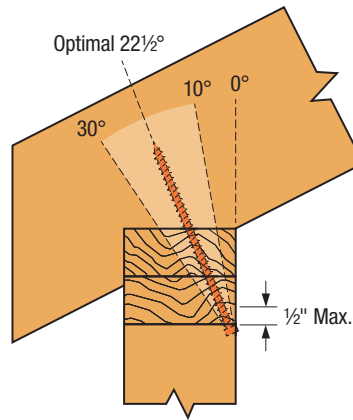

Installation Angle Limit

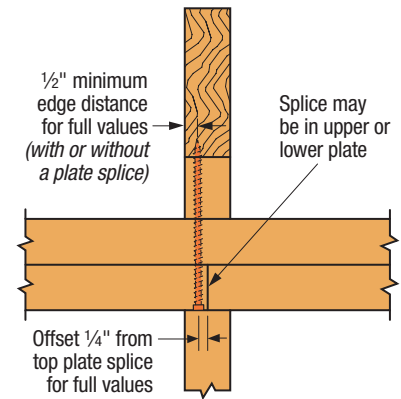

Min. Edge Distance for Top Plate Splice

Optional Roof-to-Wall Connection

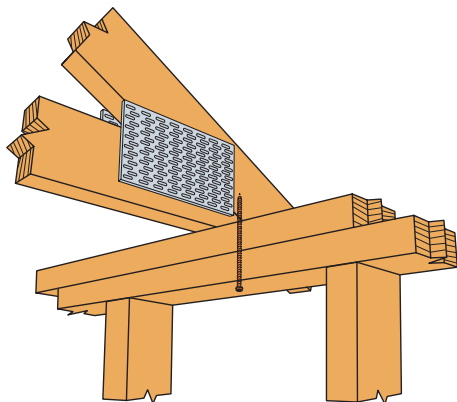

Optional Strong-Drive® SDWC Installation – Truss Offset from Stud

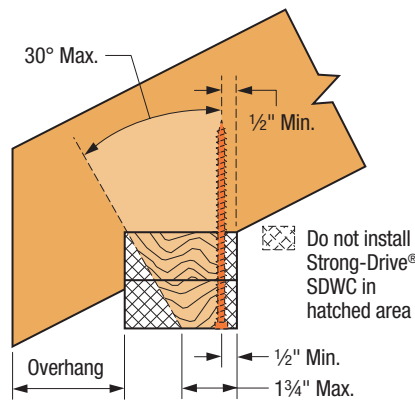

Allowable Installation Range
(Truss offset from stud only)

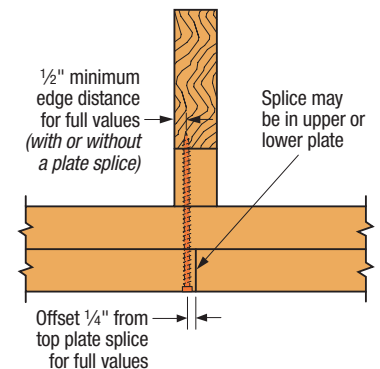

Min. Edge Distance for Top Plate Splice

STRONG-DRIVE® SDWC TRUSS Screws

Strong-Drive® SDWC Allowable Stud-to-Plate Connection Loads – DFL, SP, SPF, HF¹⁻⁷

Model No.	No. of Screws Installed	Minor Diameter (in.)	Length (in.)	Thread Length (in.)	Plate Size	Allowable Loads (160)				Code Ref.
						DF/SP		SPF/HF		
						Uplift	F ₂	Uplift	F ₂	
SDWC15450	1	0.152	4½	4¼	2x	360	215	310	153	IP5, F14
	2					690	390	595	280	
	3					1035	585	895	420	
SDWC15600	1	0.152	6	5¾	2x	450	189	310	153	
	2					865	345	595	280	
	3					1295	515	895	420	
SDWC15600	1	0.152	6	5¾	(2) 2x	590	177	510	152	
	2					1135	320	980	275	
	3					1700	485	1470	415	

1. Loads have been increased 60% for wind or earthquake loading ($C_D = 1.6$) with no further increases allowed; reduce where other loads govern.
2. Allowable loads are for Strong-Drive SDWC installed per the installation instructions.
3. The Strong-Drive SDWC15450 is to be installed through the face of 2x stud into a single 2x bottom plate over a concrete/masonry foundation.
4. The Strong-Drive SDWC15600 is to be installed through the face of 2x stud into a single 2x bottom plate over a wood floor system.
5. The Strong-Drive SDWC15600 is to be installed through the face of 2x stud into a double 2x top or bottom plate.
6. Double-top plates shall be fastened together as required by applicable Code.
7. When the screw is loaded simultaneously in more than one direction, the allowable load must be evaluated using the following unity equation: $(\text{Design Uplift} \div \text{Allowable Uplift}) + (\text{Design } F_2 \div \text{Allowable } F_2) \leq 1.0$.

Stud-to-Plate Connections

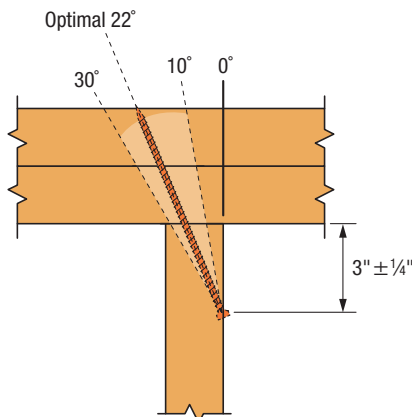

Stud-to-Top Plate Connection
(This application requires Strong-Drive SDWC15600)

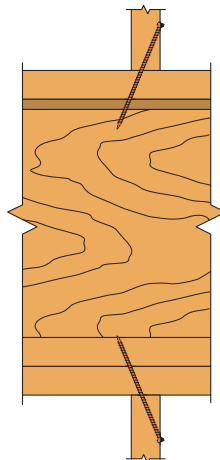

Stud-to-Bottom Plate Connection Over Wood Floor
(Strong-Drive SDWC15600 shown. See page 191 for Strong-Drive SDWF-TUW FLOOR-TO-FLOOR Connections.)

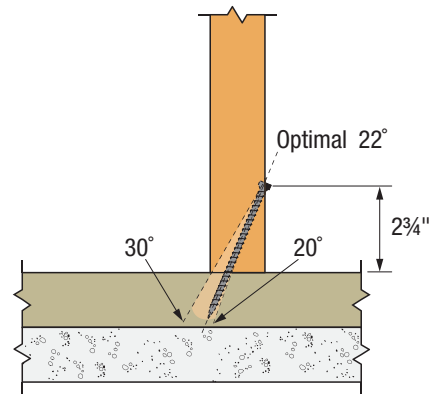

Stud-to-Bottom Plate Connection Over Concrete/Masonry Foundation
(This application requires Strong-Drive SDWC15450)

Straps & Ties



Strong-Drive SDWC15450-KT and SDWC15600-KT contains:

- (50) Strong-Drive® SDWC Truss screws
- (1) Matched-tolerance driver bit (Part no. BIT30T-2-RC3; also sold separately)
- (1) Metal installation guide tool
 - SDWC-GUIDE (for SDWC15600 only; also sold separately)
 - or
 - SDWC-GUIDE275 (for SDWC15450 only; also sold separately)

Strong-Drive SDWC15450B-KT and SDWC15600B-KT contains:

- (500) Strong-Drive® SDWC Truss screws
- (2) Matched-tolerance driver bits (Part no. BIT30T-2-RC3; also sold separately)
- (2) Metal installation guide tools
 - SDWC-GUIDE (for SDWC15600 only; also sold separately)
 - or
 - SDWC-GUIDE275 (for SDWC15450 only; also sold separately)

H Seismic & Hurricane Ties

The hurricane tie series features various configurations of wind and seismic ties for trusses and rafters.

The H16 series has a presloped seat of 5/12 for double trusses.

The presloped 5/12 seat of the H16 provides for a tight fit and reduced deflection. The strap length provides for various truss height up to a maximum of 13 1/2" (H16 series). Minimum heel height for H16 series is 4".

The HGA10 attaches to gable trusses and provides good lateral wind resistance. The HS24 attaches the bottom chord of a truss or rafter at pitches from 0/12 to 4/12 to double 2x4 top plates. Double shear nailing allows for higher lateral resistance.

MATERIAL: See table

FINISH: Galvanized. See Corrosion Information, pages 13-15.

INSTALLATION: • Use all specified fasteners. See General Notes.

- HGA10KT: sold as a kit with (10) HGA10 connectors. Simpson Strong-Tie® Strong-Drive® SDS Heavy-Duty Connector screws are included.
- HS24 requires slant nailing only when bottom chord of truss or rafter has no slope.

CODES: See page 12 for Code Reference Key Chart.

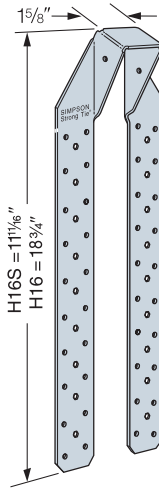

H16 and H16S

Presloped at 5/12. Truss/Rafter Pitch of 3/12 to 7/12 is acceptable

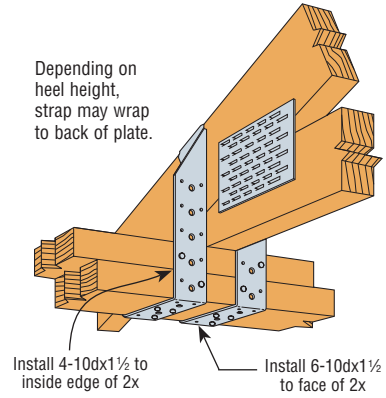

H16 Installation

Model No.	Ga	Fasteners			DF/SP Allowable Loads ¹				SPF/HF Allowable Loads ¹				Code Ref.
		To Rafters/Trusses	To Plates	To Studs	Uplift				Lateral (160)				
					(160)	F ₁	F ₂	F ₃	(160)	F ₁	F ₂	F ₃	
HGA10KT	14	4-SDS 1/4"x1 1/2"	4-SDS 1/4"x3"	—	695	1165	940	780	500	840	675	495	F26, L18
HS24	18	8-8dx1 1/2 & 2-8d slant	8-8d	—	605 ³	645 ³	1025 ³	—	520 ³	555 ³	880 ³	—	I17, F16, L6
H16	18	2-10dx1 1/2	10-10dx1 1/2	—	1470	—	—	—	1265	—	—	—	F26
H16S	18	2-10dx1 1/2	10-10dx1 1/2	—	1470	—	—	—	1265	—	—	—	
H16-2	18	2-10dx1 1/2	10-10dx1 1/2	—	1470	—	—	—	1265	—	—	—	
H16-2S	18	2-10dx1 1/2	10-10dx1 1/2	—	1470	—	—	—	1265	—	—	—	

1. Loads have been increased for wind or earthquake loading with no further increase allowed; reduce where other loads govern.
2. When cross-grain bending or cross-grain tension cannot be avoided, mechanical reinforcement to resist such forces should be considered.
3. HS24 DF/SP allowable loads without slant nailing are 605 lbs. (uplift), 590 lbs. (F₁), 640 lbs. (F₂). For SPF/HF loads multiply these values by 0.86.
4. For H16-2S, S = short.
5. Allowable loads in the F₁ direction are not intended to replace diaphragm boundary members or prevent cross grain bending of the truss or rafter members. Additional shear transfer elements shall be considered where there may be effects of cross grain bending or tension.
6. **NAILS:** 10dx1 1/2 = 0.148" dia. x 1 1/2" long, 8d = 0.131" dia. x 2 1/2" long, 8dx1 1/2 = 0.131" dia. x 1 1/2" long. See pages 22-23 for other nail sizes and information.

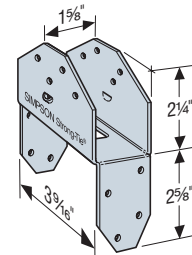

HS24

U.S. Patents 5,603,580

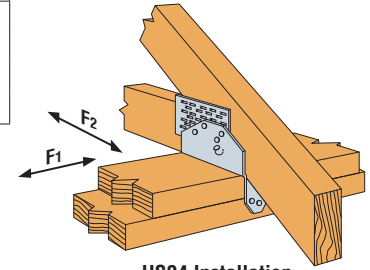

HS24 Installation

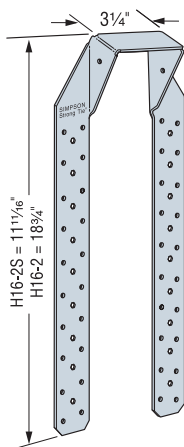

H16-2 and H16-2S

Presloped at 5/12. Pitch of 3/12 to 7/12 is acceptable

Depending on heel height, strap may wrap to back of plate.

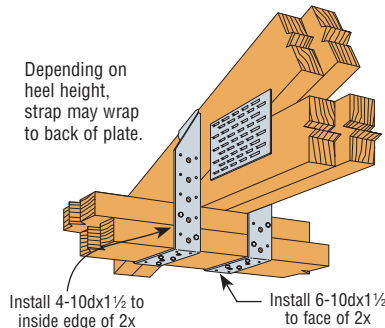

H16-2 Installation

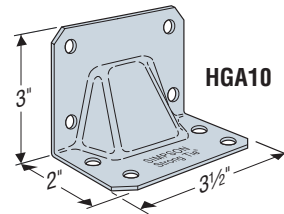

HGA10

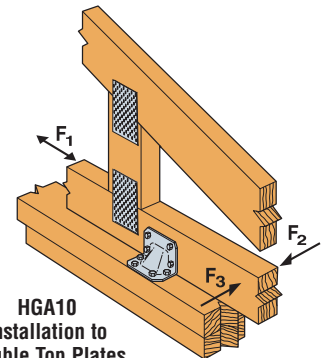

HGA10 Installation to Double Top Plates

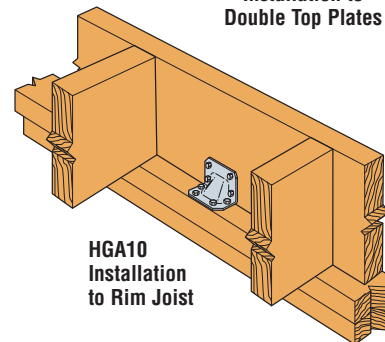

HGA10 Installation to Rim Joist

LTS/MTS/HTS Twist Straps

Twist straps provide a tension connection between two wood members. They resist uplift at the heel of a truss economically. LTS/ MTS have a 2" bend section and HTS has a 3¾" bend section that eliminates interference at the transition points between the two members.

MATERIAL: LTS—18 gauge; MTS—16 gauge; HTS—14 gauge
FINISH: Galvanized. Some products available in stainless steel and ZMAX® coating; see Corrosion Information, pages 13-15.

INSTALLATION:

- Use all specified fasteners. See General Notes.
- LTS, MTS and HTS are available with the bend reversed. Specify "-REV" after the model number, such as MTS16-REV

CODES: See page 12 for Code Reference Key Chart.

These products are available with additional corrosion protection. Additional products on this page may also be available with this option, check with Simpson Strong-Tie for details.

These products are approved for installation with the Strong-Drive® SD Connector screw. See page 27 for more information.

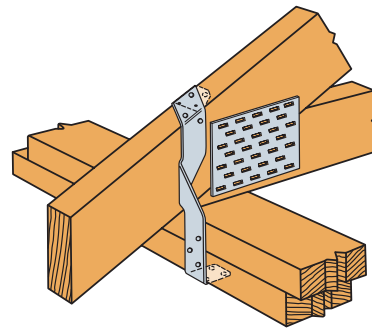
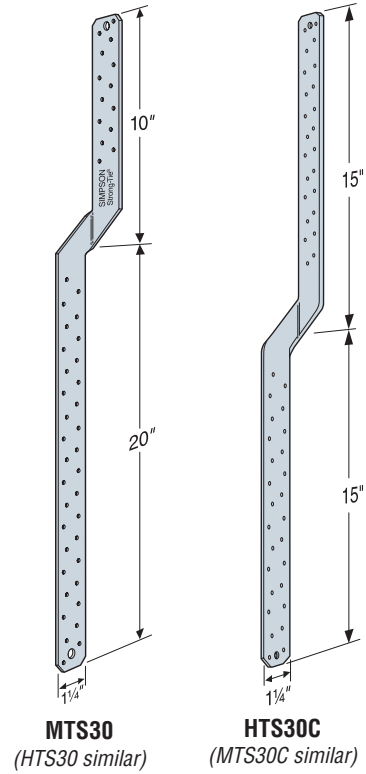
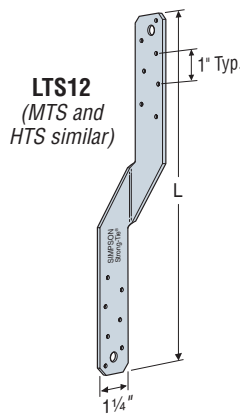

MTS Installation as a Truss-to-Top Plate Tie

Model No.	L	Fasteners		DF/SP Allowable Uplift Loads		SPF/HF Allowable Uplift Loads		Code Ref.
		10d	10dx1½	10d (160)	10dx1½ (160)	10d (160)	10dx1½ (160)	
LTS12	12	12-10d	12-10dx1½	775	720	665	620	I17, L6, F16
LTS16	16	12-10d	12-10dx1½	775	720	665	620	
LTS18	18	12-10d	12-10dx1½	775	720	665	620	
LTS20	20	12-10d	12-10dx1½	775	720	665	620	
MTS12	12	14-10d	14-10dx1½	1000	1000	860	860	I17, L5, L6, F16
MTS16	16	14-10d	14-10dx1½	1000	1000	860	860	
MTS18	18	14-10d	14-10dx1½	1000	1000	860	860	I17, L6, F16
MTS20	20	14-10d	14-10dx1½	1000	1000	860	860	I17, L5, L6, F16
MTS30	30	14-10d	14-10dx1½	1000	1000	860	860	F26
MTS24C	24	14-10d	14-10dx1½	1000	1000	860	860	
MTS30C	30	14-10d	14-10dx1½	1000	1000	860	860	
HTS16	16	16-10d	16-10dx1½	1260	1150	1085	990	I17, L6, F16
HTS20	20	20-10d	24-10dx1½	1450	1450	1245	1245	
HTS24	24	20-10d	24-10dx1½	1450	1450	1245	1245	
HTS30	30	20-10d	24-10dx1½	1450	1450	1245	1245	
HTS30C	30	20-10d	24-10dx1½	1450	1450	1245	1245	

1. Loads have been increased for wind or earthquake loading with no further increase allowed; reduce where other loads govern.
2. LTS12 thru LTS20, MTS16 through MTS30, HTS24 through HTS30C (except HTS30) have additional nail holes.
3. Install half of the fasteners on each end of strap to achieve full loads.
4. All straps except the MTS30 and HTS30 have the twist in the center of the strap.
5. Twist straps do not have to be wrapped over the truss to achieve the load.
6. May be installed on the inside face of the stud.
7. Allowable lateral loads are F₁ = 75 lbs. and F₂ = 125 lbs. when the following installation requirements are met. The first 7 nail holes each side of the bend must be filled with 10dx1½ minimum nails. All additional fasteners may be installed in any remaining strap holes.
8. **NAILS:** 10d = 0.148" dia. x 3" long, 10dx1½ = 0.148" dia. x 1½" long. See pages 22-23 for other nail sizes and information.

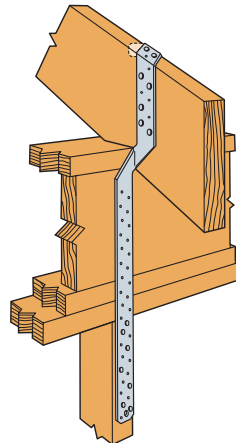

Typical MTS30 Installation

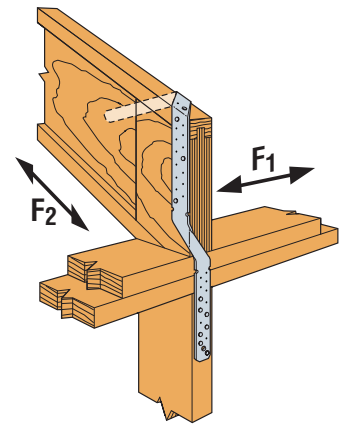

MTS30 Installation with I-joint Rafter

HTSQ Twist Strap

The HTSQ twist straps provide a tension connection between two wood members and are designed to resist uplift for decks, boardwalks and beams economically. The HTSQ is quicker, easier and more economical to install when compared to bolted straps. HTSQ provides a strong connection with fewer fasteners than nailed HTS straps when incorporating Simpson Strong-Tie® Strong-Drive® SDS Heavy-Duty Connector screws. Strong-Drive SDS screws with a double-barrier coating finish are included with HTSQ straps in a ZMAX® coating. For stainless-steel HTSQ straps, stainless-steel SDS Heavy-Duty Connector screws are provided.

FEATURES:

- Quicker and more consistent installation than bolts
- Better fastener withdrawal resistance than nails
- Corrosion resistance finish options

MATERIAL: 14 gauge

FINISH: ZMAX coating or stainless steel.

INSTALLATION:

- Use all specified fasteners. See General Notes.

CODES: See page 12 for Code Reference Key Chart.

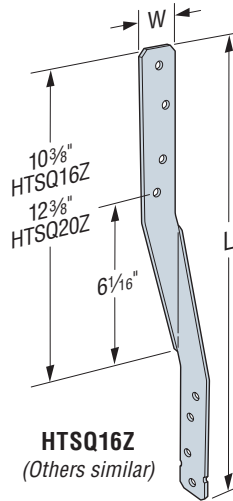

HTSQ16Z
(Others similar)

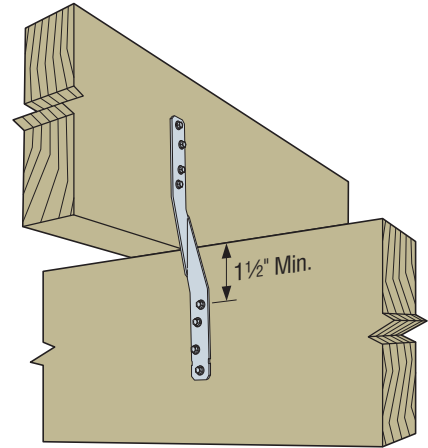

Typical HTSQ16Z Installation

These products are available with additional corrosion protection. Additional products on this page may also be available with this option, check with Simpson Strong-Tie for details.

Model No.	Dimensions (in.)		Fasteners	Allowable Uplift Loads				Code Ref.
	(W)	(L)		DF/SP		SPF/HF		
				(100)	(160)	(100)	(160)	
HTSQ16ZKT or HTSQ16SS-SDS	1 1/4	16	8-1/4"x1 1/2" SDS	1000	1145	720	800	170
HTSQ20ZKT or HTSQ20SS-SDS	1 1/4	20						

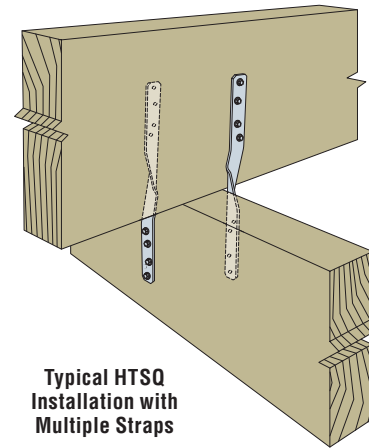

Typical HTSQ Installation with Multiple Straps

1. Uplift (160) loads have been increased for wind or earthquake loading with no further increase allowed.
2. Tabulated loads are for a single connector. Multiple connectors may be used when the fasteners do not interfere.
3. Install four fasteners in each member to achieve full loads. HTSQ20 has (2) extra holes per side to allow for installation flexibility

HH Header Hangers

For fast, accurate installation of door and window headers and other cross members. HH header hangers can speed up the job, strengthen the frame, and eliminate the need for trimmers.

MATERIAL: 16 gauge

FINISH: Galvanized

INSTALLATION: • Use all specified fasteners. See General Notes.

- Attachment to 2x studs will result in two round holes not being filled in the studs and load reductions as noted in table.

CODES: See page 12 for Code Reference Key Chart.

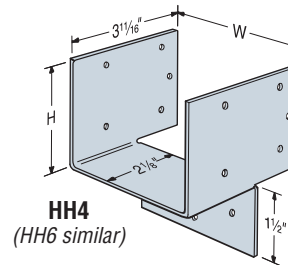

HH4
(HH6 similar)

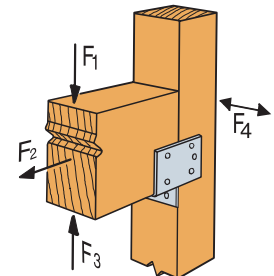

HH Load Directions

Model No.	W	H	Min. Post Size	Fasteners		DF/SP Allowable Loads					Code Ref.	
				Stud	Header	F1			F2	F3		F4
						(100)	(115)	(125)	(160)	(160)		(160)
HH4	3 1/2	2 1/16	2x	7-10dx1 1/2	4-10dx1 1/2	855	965	1035	—	575	725	170
			Dbl 2x	7-16dx2 1/2	4-16dx2 1/2	1010	1140	1195	—	710	750	
			3x	9-16d	4-16d	1295	1470	1585	780	795	1085	
HH6	5 1/2	5 1/8	2x	10-10dx1 1/2	6-10dx1 1/2	1220	1380	1480	—	1065	1025	170
			Dbl 2x	10-16dx2 1/2	6-16dx2 1/2	1440	1595	1595	—	1065	1085	
			3x	12-16d	6-16d	1730	1960	2115	1025	1105	1700	

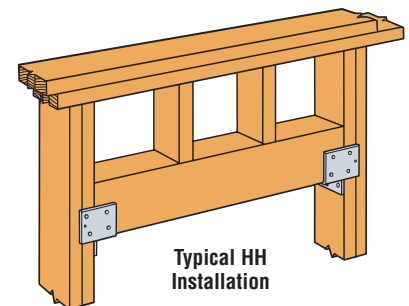

Typical HH Installation

1. Loads have been increased with no further increase allowed; reduce where other loads govern.
2. For 3x posts, 16dx2 1/2" nails may be substituted with no reduction in load.
3. For SPF/HF lumber use 0.86 x DF/SP allowable loads.
4. **NAILS:** 10dx1 1/2" = 0.148" dia. x 1 1/2" long, 16dx2 1/2" = 0.162" dia. x 2 1/2" long, 16d = 0.162" dia. x 3 1/2" long. See pages 22-23 for other nail sizes and information.

LGT/MGT/VGT/HGT Girder Tiedowns

The LGT, MGT, VGT and HGT are girder tiedowns for moderate to high load capacity applications. The LGT and VGT are also suitable for retrofit applications.

LGT connectors provide a low profile connection to the studs for easy installation of drywall. Simple to install and can be installed on the inside or outside of the wall. LGT connectors also provide exceptional bearing enhancement for heavy download applications. The LGT series has been extended to include the new LGT4-SDS3 for 4-ply girders.

The Variable Girder Tiedown (VGT) is a higher capacity alternative to the LGT and MGT for girder trusses. It attaches with Simpson Strong-Tie® Strong-Drive® SDS Heavy-Duty Connector screws to the side of truss and features a predeflected crescent washer that allows it to accommodate top chord pitches up to 8/12. The VGT is also available with one flange concealed for attachment to trusses with no tail.

The HGT offers the highest uplift capacity for girders and can be installed on trusses and beams with top chord slopes up to 8/12.

MATERIAL: HGT, VGT—7 gauge, LGT2—14 gauge, MGT, LGT3, LGT4—12 gauge.

FINISH: HGT—Simpson Strong-Tie® gray paint; LGT, MGT, VGT—Galvanized

INSTALLATION: • When the HGT-3 is used with a 2-ply girder or beam, shimming is required. Fasten to act as one unit.

- Before installing fasteners, ensure LGT3-SDS2.5 makes complete contact with bottom of truss.
- Strong-Drive SDS Heavy-Duty Connector screws included with LGT3, LGT4 and VGT Series.
- VGT—Can be installed on roof pitches up to 8/12 or on a bottom chord designed to transfer the load.
- VGT—Screw holes are configured to allow for double installation on a two-ply (minimum) truss.
- VGT—The product can be installed in a single application or in pairs to achieve a higher uplift capacity.
- VGT—When installed on trusses with no overhangs, specify VGTR/L.
- VGT—Install washer component (provided) so that top of washer is horizontal as well as parallel with top of wall top plate.
- LGT3-SDS2.5—The four large hexagon holes are intended for CMU and concrete applications.
- See pages 182-183 for masonry applications.

OPTIONS: • LGT3 and LGT4 are available with reduced widths of $W = 4\frac{3}{4}"$ and $W = 6\frac{1}{8}"$ —order as LGT3N-SDS2.5 and LGT4N-SDS3.

CODES: See page 12 for Code Reference Key Chart.

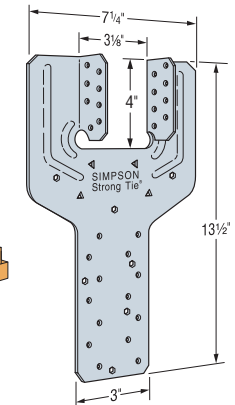
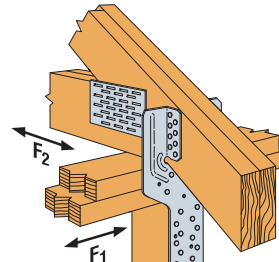
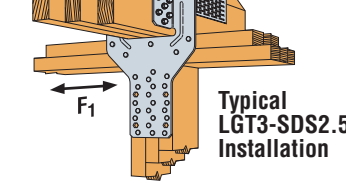
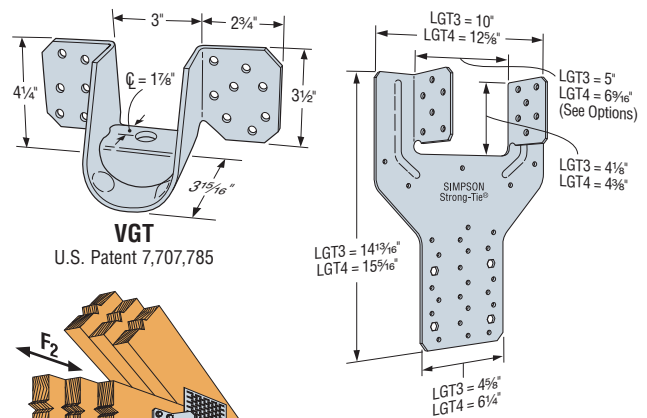

Typical LGT2 Installation

LG2

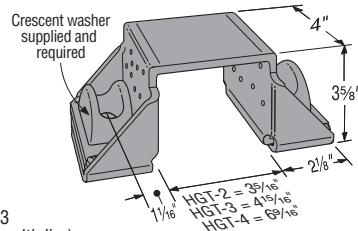

HGT-2 (HGT-3, HGT-4 similar)

Model No.	Qty.	No. of Plies	O.C. Dim. Between Anchors	Fasteners		DF/SP Allowable Uplift Loads (160)	SPF/HF Allowable Uplift Loads (160)	Code Ref.
				Nails or Anchor Diameter	Girder			
LGT2	1	2 ply	—	14-16d Sinkers	16-16d Sinkers	2050	1785	F26
LGT3-SDS2.5	1	3 ply	—	26-16d Sinkers	12-SDS 1/4"x2 1/2"	3685	2655	
LGT4-SDS3	1	4 ply	—	30-16d Sinkers	16-SDS 1/4"x3"	4060	2925 ⁵	
MGT	1	2 ply min.	—	1-5/8"	22-10d	3965	3300	
VGT	2	2 ply min.	—	1-5/8"	16-SDS 1/4"x3"	4940	3555	I17, L10, L16, F16
		3 ply min.	—	2-5/8"	32-SDS 1/4"x3"	7185	5175	
VGTR/L	1	2 ply min.	—	1-5/8"	16-SDS 1/4"x3"	2230	1605	
		2 ply min.	—	2-5/8"	32-SDS 1/4"x3"	5545	3990	
HGT-2	1	2 ply	5 3/4"	2-5/8"	16-10d	10980	6485	
HGT-3	1	3 ply	7 3/8"	2-5/8"	16-10d	10530	9035	
HGT-4	1	4 ply	9"	2-5/8"	16-10d	9250	9250	

1. Allowable loads have been increased for wind or earthquake loading with no further increase allowed. Reduce where other loads govern.
2. LGT2—F₁ load = 700 lbs.; F₂ load = 170 lbs. with installation of 4-16d sinkers optional nail holes.
3. LGT3—F₁ load = 795 lbs.; F₂ load = 410 lbs.
4. LGT4—F₁ load = 2000 lbs.; F₂ load = 675 lbs. with installation of 7-16d sinkers in optional nail holes.
5. LGT4—Uplift for DF/SP girder and SPF studs is 3860 lbs.
6. MGT can be installed with straps vertical for full table load provided all specified nails are installed to either a solid header or minimum double 2x6 web.
7. LGT connectors can provide bearing enhancement loads for truss download reactions. The DF/SP allowable load shall be

- 2060 lbs. for LGT2 and 4100 lbs. for LGT3 and LGT4 (for SPF/HF values use a 0.68 multiplier). For more information refer to technical bulletin T-HTIEBEARING.
8. Girder tiedowns installed on the outside of the wall require a 3/8" overhang to achieve table loads.
9. Simpson Strong-Tie® Strong-Drive® SDS Heavy-Duty Connector screws are permitted to be installed through metal truss plates as approved by the Truss Designer, provided the requirements of ANSI/TPI 1-2007 Sections 7.5.3.4 and 8.9.2 are met (pre-drilling required through the plate using a maximum of 5/32" bit).
10. **NAILS:** 16d Sinker = 0.148" dia. x 3 1/4" long, 10d = 0.148" dia. x 3" long. See pages 22-23 for other nail sizes and information.

Install two LBP^{5/8} washers on top of each crescent washer (total four 5/8" washers) for wood installation. All washers and crescent washers are required. Crescent washers are supplied.

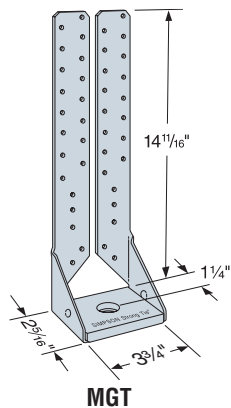

MGT

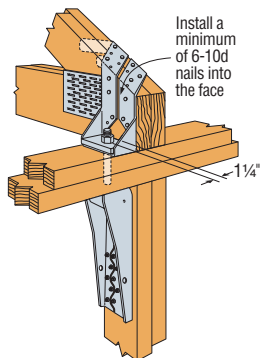

Typical MGT Installation with HDU4

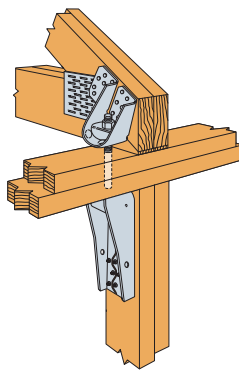

Typical VGTR Single Installation with HDU2

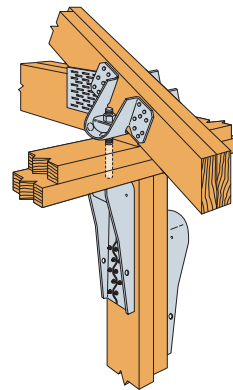

Typical VGT Double Installation with HDU4's

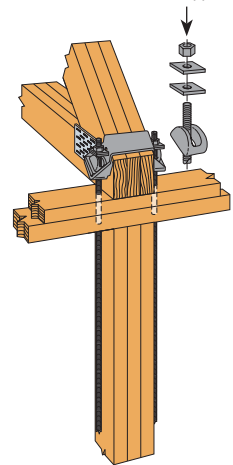

Typical HGT-3 Installation with Full Height Threaded Rod

DSP/SSP/SP/SPH/RSP4/TSP Stud Plate Ties



This product is preferable to similar connectors because of a) easier installation, b) higher loads, c) lower installed cost, or a combination of these features.

The Stud Plate Tie series offers general solutions for connecting the stud to the top and bottom plates. All models can be used to make a connection to either the top or bottom plate, and several are suitable for double top plates and studs.

MATERIAL: DSP/SSP/SPH—18 gauge; TSP—16 gauge; all others—20 gauge
FINISH: Galvanized. Some products available in ZMAX® coating; see Corrosion Information, pages 13-15.

INSTALLATION: • Use all specified fasteners; see General Notes.

- TSP/DSP/SSP—sill plate installation—fill all round holes.
- TSP/DSP/SSP—top plate installation—fill all round and triangle holes
- SP1/SP2/SP3/SP5—one of the 10d common stud nails is driven at a 45° angle through the stud into the plate.

CODES: See page 12 for Code Reference Key Chart.

These products are available with additional corrosion protection. Additional products on this page may also be available with this option, check with Simpson Strong-Tie for details.

These products are approved for installation with the Strong-Drive® SD Connector screw. See page 27 for more information.

Model No.	Dim.		Fasteners			Allowable Uplift Loads (160)			Code Ref.
	W	L	Studs	Double Top Plate	Single Sill Plate	Double Top Plate		Single Sill Plate	
						DF/SP/SPF	DF/SP		
SSP	1½	6¼	4-10dx1½	3-10dx1½	—	350	—	—	I17, L18, F16
				—	1-10dx1½	—	420	325	
			4-10d	—	—	435	—	—	
DSP	2¾	6¼	8-10dx1½	6-10dx1½	—	775	—	—	
				—	2-10dx1½	—	660	545	
			8-10d	6-10d	—	825	—	—	
TSP	1½	7¾	6-10dx1½	3-10dx1½	—	—	470 ^a	425	F26
				—	6-10d	—	755 ^a	—	
			9-10dx1½	6-10d	—	1015 ^a	—	—	

1. Allowable loads have been increased 60% for wind or earthquake loading with no further increase allowed.
2. When cross-grain bending or cross-grain tension cannot be avoided, mechanical reinforcement to resist such forces should be considered.
3. Allowable loads for DSP installed to a rim joist are 660 lbs. (DF/SP), 545 lbs. (SPF/HF).
4. Noted values only apply to DF/SP members. For SPF values, multiply by 0.86.
5. Southern pine allowable uplift load is 585 lbs.
6. **NAILS:** 10d = 0.148" dia. x 3" long, 10dx1½ = 0.148" dia. x 1½" long. See pages 22-23 for other nail sizes and information.

Model No.	Dim.		Stud	Plate Width	Fasteners		Allowable Uplift Loads				Code Ref.
	W	L			Stud ¹	Plate	DF/SP (160)		SPF/HF (160)		
							Side ²	Center ³	Side ²	Center ³	
SP1	3½	5½	2x	—	6-10d	4-10d	585	585	535	535	I17, F16, L6
SP2	3½	6¾	2x	—	6-10d	6-10d	1065	1065	605	605	
SP4	3¾	7¼	2x	4x	6-10dx1½	—	440	885	380	760	
SP6	5½	7¾	2x	6x	6-10dx1½	—	440	885	380	760	
SP8	7½	8¾	2x	8x	6-10dx1½	—	440	885	380	760	
SPH4 or SPH4R	3¾	8¼	2x	4x	10-10dx1½	—	620	1240	530	1065	
SPH6 or SPH6R	5½	9¼	2x	6x	10-10dx1½	—	680	1360	585	1170	I17, F16, L6
					12-10dx1½	—	680	1360	585	1170	
SPH8	7½	8¾	2x	8x	10-10dx1½	—	620	1240	530	1065	I17, F16, L6
					12-10dx1½	—	680	1360	585	1170	
RSP4(1)	2½	4½	2x	—	4-8dx1½	4-8dx1½	315	315	285	285	I17, L5,
RSP4(2)	2½	4½	2x	—	4-8dx1½	4-8dx1½	450	450	370	370	L6, F16

1. SP1/SP2—drive one stud nail at an angle through the stud into the plate to achieve the table load (see illustration).
2. Allowable loads have been increased for wind or earthquake loading with no further increase allowed. Reduce where other loads govern.
3. RSP4—see Installation details (1) and (2) for reference.
4. RSP4 F₂ is 250 lbs. (installation 1) and 250 lbs. (installation 2). F₁ load is 210 lbs. for both installations.
5. Maximum load for SPH in Southern Yellow Pine is 1490 lbs for center loading and 745 lbs for side loading.
6. When cross-grain bending or cross-grain tension cannot be avoided, mechanical reinforcement to resist such forces should be considered.
7. For retrofit application see technical bulletin T-C-STRAPS.
8. Use Side (eccentric) load when uplift loads are applied to only one face of the top plate.
9. Use Center (concentric) loads when uplift loads are applied at the centerline of the top plate, or where equal loads are applied to both sides of the top plate. Center loads should also be used for stud to bottom plate loads.
10. **NAILS:** 10d = 0.148" dia. x 3" long, 10dx1½ = 0.148" dia. x 1½" long, 8dx1½ = 0.131" dia. x 1½" long. See pages 22-23 for other nail sizes and information.

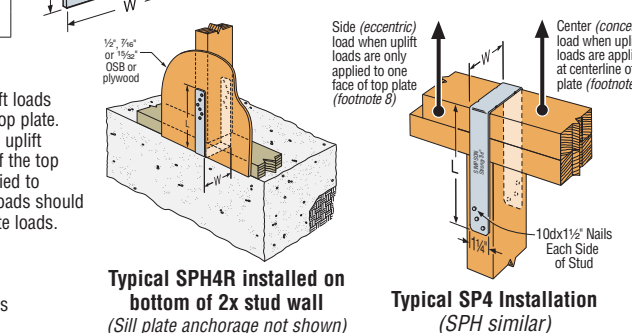
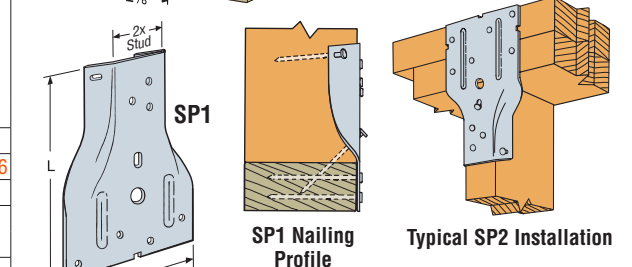
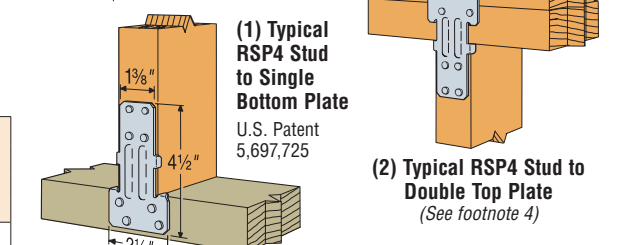
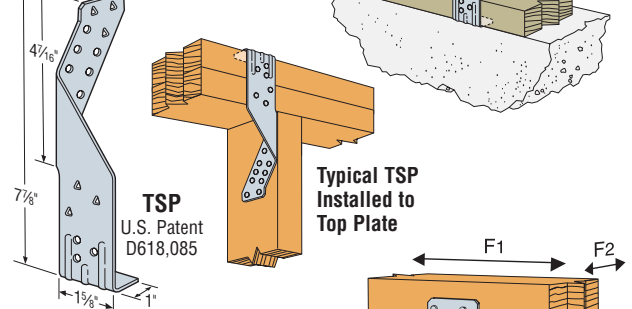
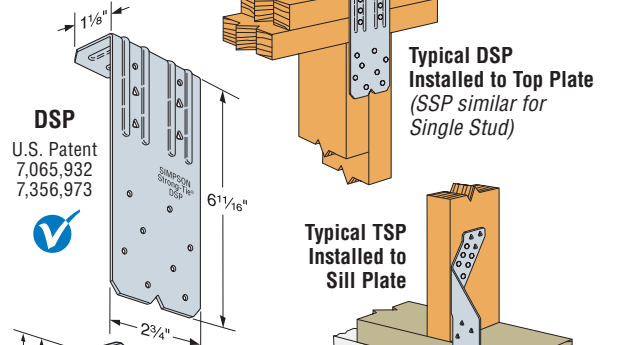
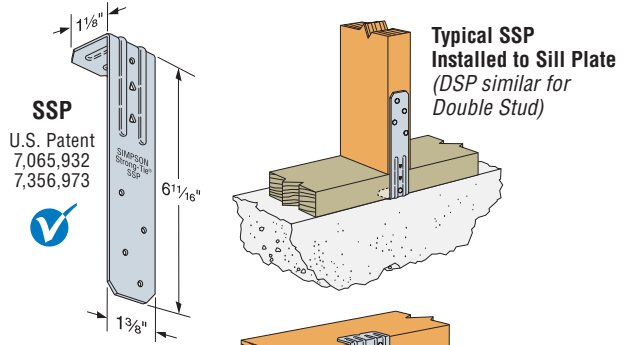

Straps & Ties

LTP4/LTP5/A34/A35 Framing Angles & Plates

The larger LTP5 spans subfloor at the top of the blocking or rim joist. The embossments enhance performance.

The LTP4 Lateral Tie Plate transfers shear forces for top plate-to-rim joist or blocking connections. Nail holes are spaced to prevent wood splitting for single and double top plate applications. May be installed over plywood sheathing.

The A35 anchor's exclusive bending slot allows instant, accurate field bends for all two- and three-way ties. Balanced, completely reversible design permits the A35 to secure a great variety of connections.

MATERIAL: LTP4/LTP5—20 gauge; all others—18 gauge

FINISH: Galvanized. Some products available in stainless steel or ZMAX® coating; see Corrosion Information, pages 13-15.

INSTALLATION: • Use all specified fasteners. See General Notes.

• A35—Bend one time only.

CODES: See page 12 for Code Reference Key Chart.

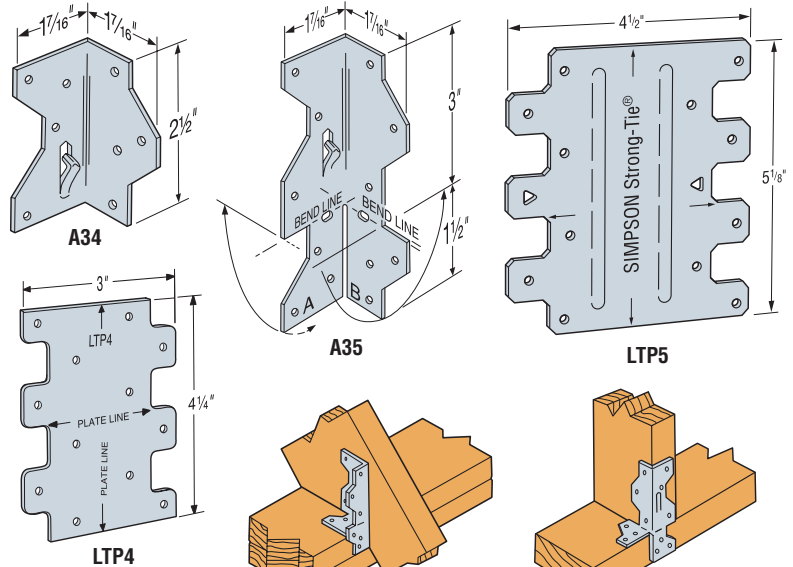

These products are available with additional corrosion protection. Additional products on this page may also be available with this option, check with Simpson Strong-Tie for details.

These products are approved for installation with the Strong-Drive® SD Connector screw. See page 27 for more information.

Model No.	Type of Connection	Fasteners	Direction of Load	DF/SP Allowable Loads			SPF/HF Allowable Loads			Code Ref.	
				Floor (100)	Roof (125)	(160)	Floor (100)	Roof (125)	(160)		
A34	1	8-8dx1 1/2	F1	395	485	515	340	415	445	IP1, L5, L18, F13	
			F2 ⁵	395	455	455	340	390	390		
A35	2	9-8dx1 1/2	A1, E	295	365	395	255	315	340		
			C1	210	210	210	180	180	180		
	3	12-8dx1 1/2	A2	295	365	380	255	315	325		
			C2	295	365	370	255	315	320		
	4	12-8dx1 1/2	D	230	230	230	200	200	200		
			F1	595	695	695	510	600	600		
LTP4	5	12-8dx1 1/2	G	580	670	670	500	570	575		I14, L5, F13
			H	580	600	600	500	515	515		
LTP5	6	12-8dx1 1/2	G	580	620	620	500	535	535		IP1, L18, F25
			H	545	545	545	470	470	470		

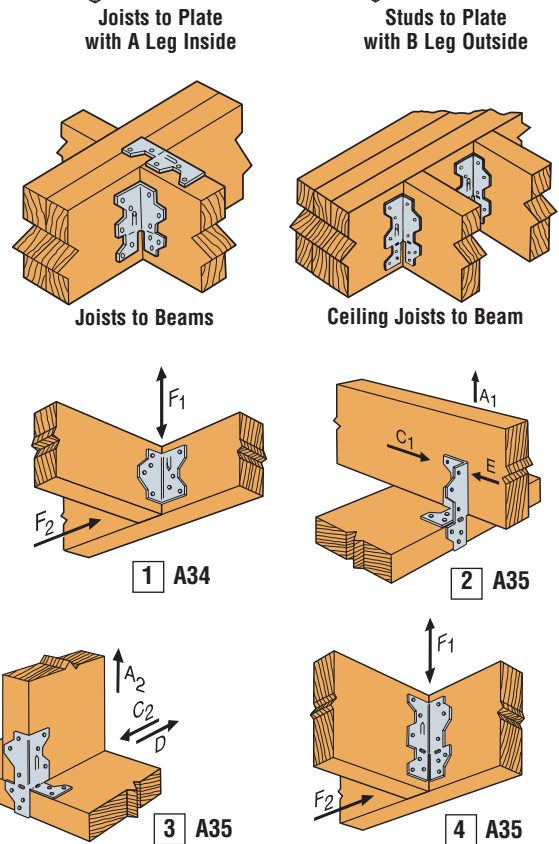

- Allowable loads are for one anchor. When anchors are installed on each side of the joist, the minimum joist thickness is 3".
- Some illustrations show connections that could cause cross-grain tension or bending of the wood during loading if not reinforced sufficiently. In this case, mechanical reinforcement should be considered.
- LTP4 can be installed over 3/8" wood structural panel sheathing with 8dx1 1/2 nails and achieve 0.72 of the listed load, or over 1/2" and achieve 0.64 of the listed load. 8d commons will achieve 100% load.
- The LTP5 may be installed over wood structural panel sheathing up to 1/2" thick using 8dx1 1/2 nails with no reduction in load.
- Connectors are required on both sides to achieve F2 loads in both directions.
- NAILS:** 8dx1 1/2 = 0.131" dia. x 1 1/2" long. See pages 22-23 for other nail sizes and information.

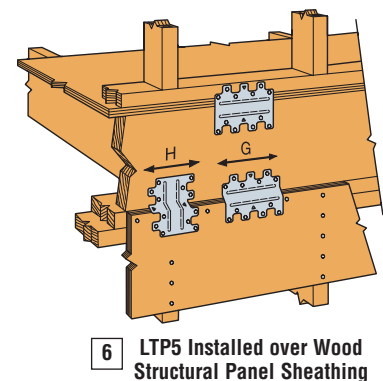
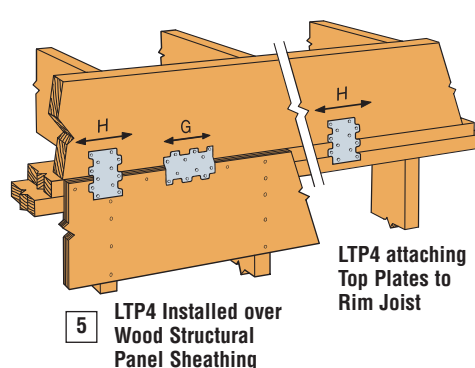
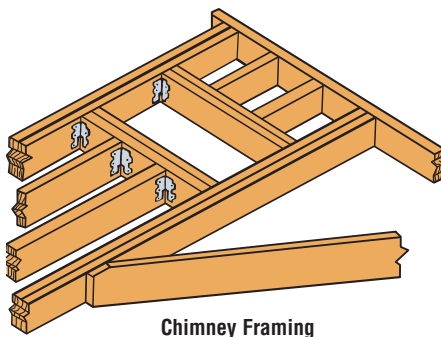

RBC Roof Boundary Clip

The RBC Roof Boundary Clip is designed to aid installation and transfer shear loads between the roof diaphragm and wall. The locator tabs make proper location of the clip easy. The RBC can be used on wood or masonry walls and will handle roof pitches from 0/12 to 12/12.

MATERIAL: 20 gauge **FINISH:** Galvanized

INSTALLATION: • Use all specified fasteners. See General Notes.

- Field bend to desired angle – one time only.
- See flier F-C-RBC for more information on installation and code requirements.

CODES: See page 12 for Code Reference Key Chart.

The RBC installed to blocking resists rotation and lateral displacement of rafter or truss.

Code references:

- IRC 2009/2012, R802.8 Lateral Support
- IBC 2009/2012, 2308.10.6 Blocking

Blocking allows proper edge nailing of sheathing.

Code references:

- IRC 2009/2012, Table R602.3(1), footnote i
- IBC 2009/2012, 2305.1.4 Shear Panel Connections

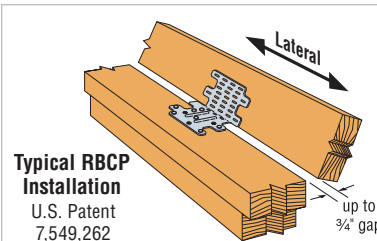
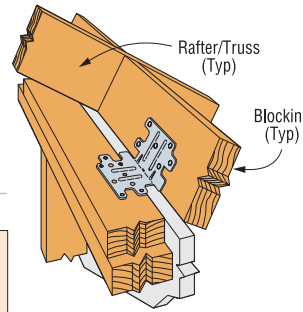
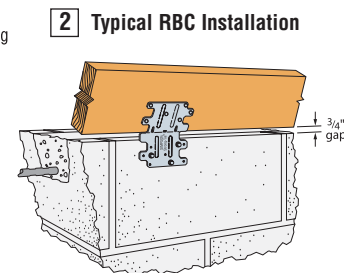
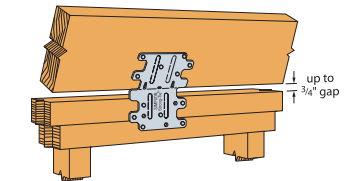
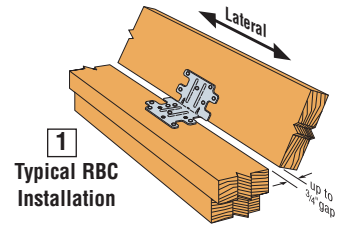
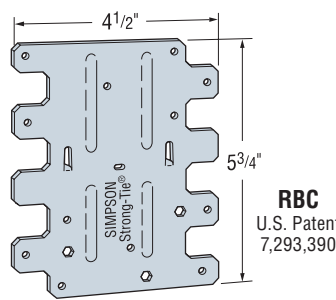

The RBC is available with prongs into one side (RBCP) for pre-attachment of the part to a block at the truss plant. Refer to technical bulletin T-RBCP for more information.

Model No.	Type of Connection	Bending Angle	Fasteners		DF/SP Allowable Loads	SPF/HF Allowable Loads	Code Ref.
			To Wall	To Blocking	Lateral (160)	Lateral (160)	
RBC	1	45° to 90°	6-10dx1½	6-10dx1½	445	380	IP1, L18, F25
	2	< 30°	6-10dx1½	6-10dx1½	435	375	
		30° to 45°	6-10dx1½	6-10dx1½	480	415	
3	0° to 45°	3-½x2¼ Titen ⁴	6-10dx1½	350	350		

1. Allowable loads are for one anchor attached to blocking minimum 1½" thick.
2. RBC can be installed with up to ¾" gap and achieve 100% of the listed load.
3. Allowable loads have been increased for wind or earthquake loading with no further increase allowed. Reduce where other loads govern.
4. When attaching to concrete use 3-½x1¾" Titen[®] screws.
5. RBC installed over 1" foamboard has a load of 395 lbs. (160) in a parallel to wall (F₁) load direction for Douglas Fir. For SPF, the load is 340 lbs.
6. RBC may be installed over ½" structural sheathing using 10dx1½ nails with no load reduction.
7. **NAILS:** 10dx1½ = 0.148" dia. x 1½" long. See pages 22-23 for other nail sizes and information.

A Angles

Our line of angles provides a way to make a wide range of 90° connections.

MATERIAL: A21 and A23—18 ga.; all other A angles—12 ga.

FINISH: Galvanized. Some products available in stainless steel or ZMAX[®] coating; see Corrosion Information, pages 13-15.

INSTALLATION: • Use all specified fasteners. See General Notes.

CODES: See page 12 for Code Reference Key Chart.

These products are available with additional corrosion protection. Additional products on this page may also be available with this option, check with Simpson Strong-Tie for details.

These products are approved for installation with the Strong-Drive[®] SD Connector screw. See page 27 for more information.

Model No.	Dimensions			Fasteners				Allowable Loads DF/SP (160)		Code Ref.
	W ₁	W ₂	L	Base		Post		F ₁ ³	F ₂	
				Bolts	Nails	Bolts	Nails			
A21	2	1½	1¾	—	2-10dx1½	—	2-10dx1½	365	175	I14,
A23	2	1½	2¾	—	4-10dx1½	—	4-10dx1½	715	565	L5, F13
A33	3	3	1½	—	4-10d	—	4-10d	800	330	L3, L18,
A44	4¾	4¾	1½	—	4-10d	—	4-10d	800	295	IP1
A66	5½	5½	1½	2-¾	3-10d	2-¾	3-10d	—	—	180
A88	8	8	2	3-¾	4-10d	3-¾	4-10d	—	—	
A24	3¾	2	2½	1-½	—	1-½	2-10d	—	—	
A311	11	3¾	2	1-½	—	1-½	4-10d	—	—	

1. Allowable loads have been increased for wind or earthquake loading with no further increase allowed. Reduce where other loads govern.
2. For SPF/HF lumber use 0.86 of table loads.
3. Connectors are required on both sides to achieve
4. **NAILS:** 10dx1½ = 0.148" dia. x 1½" long, 10d = 0.148" dia. x 3" long. See pages 22-23 for other nail sizes and information.

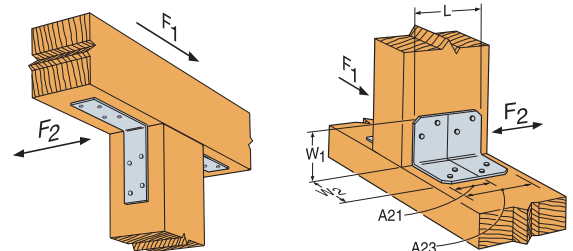

A44 Installation
(A33 similar)

A21/A23 Installation

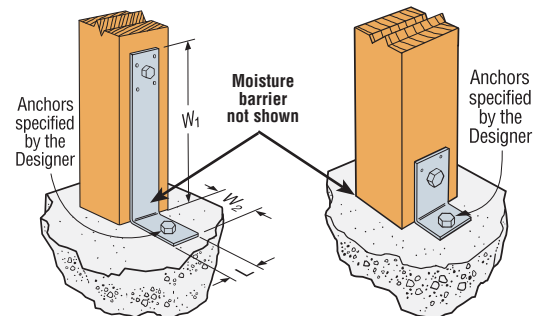

A311 Installation

A24 Installation

Z Clips

Z clips secure 2x4 flat blocking between joists or trusses to support sheathing.

MATERIAL: See table **FINISH:** Galvanized

INSTALLATION: • Use all specified fasteners; see General Notes.

- Z clips do not provide lateral stability. Do not walk on stiffeners or apply load until diaphragm is installed and nailed to stiffeners.

CODES: See page 12 for Code Reference Key Chart.

Model No.	Ga	Dimensions				Fasteners ¹ (Total)	Allowable Download (100)	Code Ref.
		W	H	B	TF			
Z2	20	2 ⁵ / ₁₆	1 ¹ / ₂	1 ³ / ₈	1 ³ / ₈	4-10dx1 ¹ / ₂	470	L18
Z4	12	1 ¹ / ₂	3 ¹ / ₂	2 ¹ / ₈	1 ³ / ₈	2-16d	465	I14, L18, F13
Z28	28	2 ⁵ / ₁₆	1 ¹ / ₂	1 ³ / ₈	1 ³ / ₈	10dx1 ¹ / ₂ ¹	—	170
Z38	28	2 ⁵ / ₁₆	2 ¹ / ₂	1 ³ / ₈	1 ³ / ₈	10dx1 ¹ / ₂ ¹	—	
Z44	12	2 ¹ / ₂	3 ¹ / ₂	2	1 ³ / ₈	4-16d	865	I14, L18, F13

1. Z28 and Z38 do not have nail holes. Fastener quantity and type shall be per Designer.
2. Allowable loads may not be increased.
3. Z4 loads apply with a nail into the top and a nail into the seat.
4. **NAILS:** 16d = 0.162" dia. x 3¹/₂" long, 10dx1¹/₂ = 0.148" dia. x 1¹/₂" long. See pages 22-23 for other nail sizes and information.

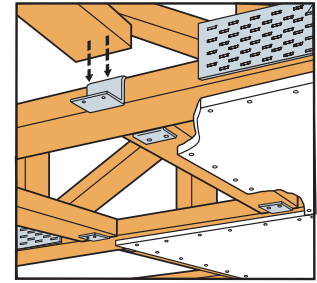
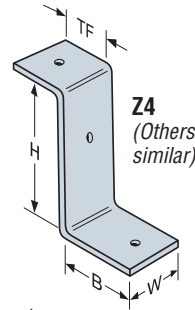

Typical Z2 Installation

HL Heavy Angles and Gussets

Versatile angle gussets and heavy angles promote standardization and construction economy, and are compatible with Simpson Strong-Tie® structural hardware.

FINISH: 7 ga Models—Galvanized; 3 ga Models—Simpson Strong-Tie® gray paint. May be ordered HDG. Contact Simpson Strong-Tie.

OPTIONS: Gussets may be added to HL models when L ≥ 5" (specify G after model number, as in HL46G).

CODES: See page 12 for Code Reference Key Chart.

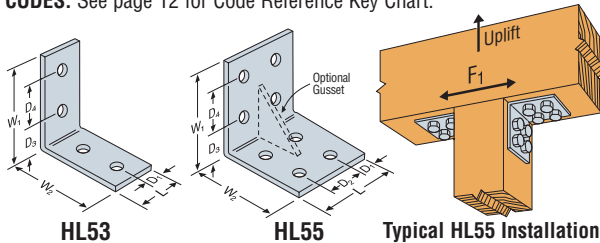

These products are available with additional corrosion protection. Additional products on this page may also be available with this option, check with Simpson Strong-Tie for details.

Model No.	Ga	Dimensions						Bolts (Total)	Dia	Allowable Loads		Code Ref.
		W ₁ & W ₂	L	D ₁	D ₂	D ₃	D ₄			Uplift	F ₁	
HL33	7	3 ³ / ₄	2 ¹ / ₄	1 ¹ / ₄	—	2	—	2	1/2	910	1580	170
HL35	7	3 ³ / ₄	5	1 ¹ / ₄	2 ¹ / ₂	2	—	4	1/2	910	1580	
HL37	7	3 ³ / ₄	7 ¹ / ₂	1 ¹ / ₄	2 ¹ / ₂	2	—	6	1/2	910	1580	
HL53	7	5 ³ / ₄	2 ¹ / ₄	1 ¹ / ₄	—	2	2 ¹ / ₂	4	1/2	910	1580	
HL55	7	5 ³ / ₄	5	1 ¹ / ₄	2 ¹ / ₂	2	2 ¹ / ₂	8	1/2	910	1580	
HL57	7	5 ³ / ₄	7 ¹ / ₂	1 ¹ / ₄	2 ¹ / ₂	2	2 ¹ / ₂	12	1/2	910	1580	
HL43	3	4 ¹ / ₄	3	1 ¹ / ₂	—	2 ³ / ₄	—	2	3/4	1555	1580	
HL46	3	4 ¹ / ₄	6	1 ¹ / ₂	3	2 ³ / ₄	—	4	3/4	1555	2025	
HL49	3	4 ¹ / ₄	9	1 ¹ / ₂	3	2 ³ / ₄	—	6	3/4	1555	2025	
HL73	3	7 ¹ / ₄	3	1 ¹ / ₂	—	2 ³ / ₄	3	4	3/4	1555	2025	
HL76	3	7 ¹ / ₄	6	1 ¹ / ₂	3	2 ³ / ₄	3	8	3/4	2115	3800	
HL79	3	7 ¹ / ₄	9	1 ¹ / ₂	3	2 ³ / ₄	3	12	3/4	2115	3800	

1. Allowable loads have been increased 60% for wind or earthquake loading with no further increase allowed; reduce where other loads govern.
2. Use 0.85 times table load for Hem Fir.
3. Parts should be centered on the face of the member to which they are attached.
4. Wood members for the '3' and '5' series must have a minimum width and thickness of 3¹/₂" for table loads to apply.
5. Wood members for the '4' and '7' series must have a minimum width and thickness of 5¹/₂" for table loads to apply.
6. Parts must be used in pairs.
7. Lag bolts of equal diameter (minimum 5" long) may be substituted for machine bolts into beam with no reduction in load.

L/LS/GA Reinforcing and Skewable Angles

L—Staggered nail pattern reduces the possibility for splitting. LS—Field-adjustable 0° to 135° angles. The GA Gusset Angles' embossed bend section provides added strength.

MATERIAL: L—16 gauge; GA and LS—18 gauge

FINISH: Galvanized. Some products available in stainless steel or ZMAX® coating; see Corrosion Information, pages 13-15.

INSTALLATION: • Use all specified fasteners; see General Notes.

- LS—field skewable; bend one time only.
- Joist must be constrained against rotation (for example, with solid blocking) when using a single LS per connection.
- Nail the L angle's wider leg into the joist to ensure table loads and allow correct nailing.

CODES: See page 12 for Code Reference Key Chart.

These products are available with additional corrosion protection. Additional products on this page may also be available with this option, check with Simpson Strong-Tie for details.

Model No.	Fasteners	L	DI/SP Allowable Loads				SPF/HF Allowable Loads				Code Ref.
			Floor (100)	Snow (115)	Roof (125)	Wind/Seismic (160)	Floor (100)	Snow (115)	Roof (125)	Wind/Seismic (160)	
GA1	4-10dx1 ¹ / ₂	2 ³ / ₄	235	270	290	330	200	230	250	285	IP1, L5, L18, F13
GA2	6-10dx1 ¹ / ₂	3 ³ / ₄	355	405	435	550	305	350	375	475	
L30	4-10dx1 ¹ / ₂	3	245	250	250	250	210	215	215	215	IP1, L5, F13
L50	6-10dx1 ¹ / ₂	5	365	415	445	555	315	355	385	475	
L70	8-10dx1 ¹ / ₂	7	485	550	595	740	415	475	510	635	
L90	10-10dx1 ¹ / ₂	9	610	690	740	925	525	595	635	795	
LS30	6-10dx1 ¹ / ₂	3 ³ / ₄	325	325	325	325	280	280	280	280	IP1, L5, L18, F13
	6-10d		355	395	395	395	305	340	340	340	
LS50	8-10dx1 ¹ / ₂	4 ³ / ₄	475	540	565	565	410	465	485	485	
	8-10d		475	540	585	730	410	465	505	630	
LS70	10-10dx1 ¹ / ₂	6 ³ / ₄	595	640	640	640	510	550	550	550	
	10-10d		595	675	730	915	510	580	630	785	
LS90	12-10dx1 ¹ / ₂	7 ³ / ₄	715	810	845	845	615	695	725	725	
	12-10d		715	810	875	1040	615	695	755	895	

1. L angles—loads are for condition F₁ or F₂; LS angles—loads are for condition F₁ only.
2. GA1 and GA2 angles table loads are F₁ — loads for F₂ are 235 lbs. and 355 lbs. (100) and 290 lbs. and 435 lbs. (125), respectively.
3. Roof loads are 125% of floor loads unless limited by other criteria.
4. Connectors are required on both sides to achieve F₂ loads in both directions.
5. GA angles may be installed with 10d nails.
6. **NAILS:** 10d = 0.148" dia. x 3" long, 10dx1¹/₂ = 0.148" dia. x 1¹/₂" long. See pages 22-23 for other nail sizes and information.

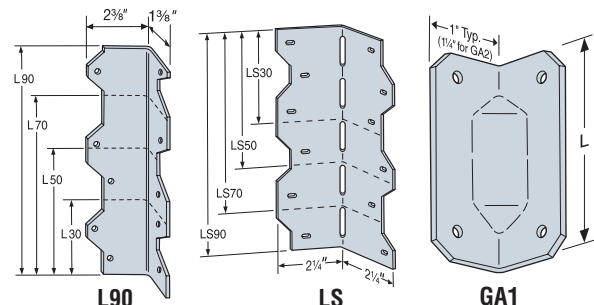

These products are approved for installation with the Strong-Drive® SD Connector screw. See page 27 for more information.

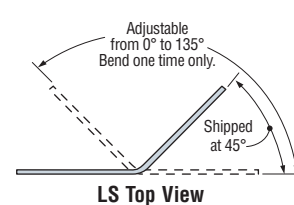

LS Top View

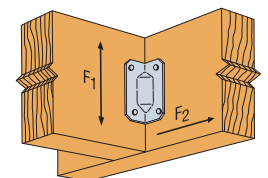

Typical GA Installation

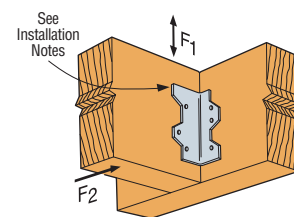

Typical L50 Installation

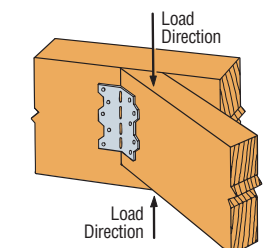

Typical LS70 Installation

DTT Deck Tension Ties

DTT tension ties are safe, cost-effective connectors designed to meet or exceed code requirements for deck construction. These versatile DTT connectors are also load rated as a holddown for light-duty shearwalls and braced wall panel applications.

For new construction or to make an existing current deck code-compliant, the DTT1Z can be used as a tension-tie to satisfy the 2015 IRC provision for a 750 lbs. lateral load connection to the house at four locations per deck. This new code detail permits the lateral connection from the deck joists to be made to top plates, studs, or headers within the supporting structure, which eliminates the need to access to the floor joists inside the home.

The new DTT1Z fastens to the narrow or wide face of a single 2x with Simpson Strong-Tie® Strong-Drive® SD Connector screws or nails and accepts a 3/8" machine bolt, anchor bolt, or lag screw (*washer required*) or can be installed with the new Strong-Drive SDWH Timber-Hex HDG screw with an integral washer. The DTT2 fastens easily to the wide face of a single or double 2x using Simpson Strong-Tie Strong-Drive SDS Heavy-Duty Connector screws (included) and accepts a 1/2" machine bolt or anchor bolt.

The DTT2 can be used to satisfy the IRC provision for a 1,500 lbs. lateral load connection at two locations per deck. Additionally, the DTT2 has been tested and evaluated in deck guardrail post applications to resist the code-specified lateral forces at the top of railing assemblies. The DTT2 is also available with longer 2 1/2" Strong-Drive SDS Heavy-Duty Connector screws (*model DTT2Z-SDS2.5*) to achieve higher loads when needed.

MATERIAL: 14 gauge

FINISH: DTT1Z/DTT2Z—ZMAX® coating;
DTT2SS—Stainless steel; see Corrosion Information, pages 13-15.

INSTALLATION:

- Use all specified fasteners. See General Notes.
- A standard cut washer (*included*) must be installed between the nut and the seat.
- Simpson Strong-Tie Strong-Drive SDS Heavy-Duty Connector screws install best with a low speed high torque drill with a 3/8" hex head driver.
- Strong-Drive SD Connector screws install with a 1/4" hex head driver.
- Strong-Drive SDWH Timber-Hex HDG screws install with a 3/8" hex head driver.

CODES: See page 12 for Code Reference Key Chart.

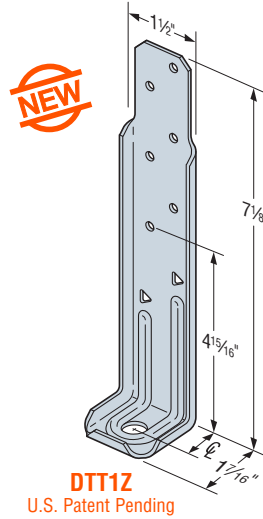

DTT1Z
U.S. Patent Pending

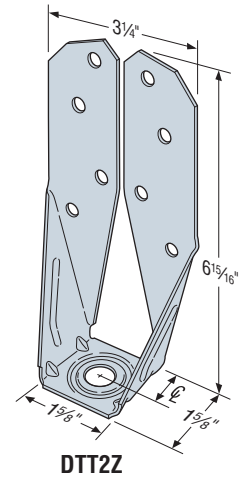

DTT2Z

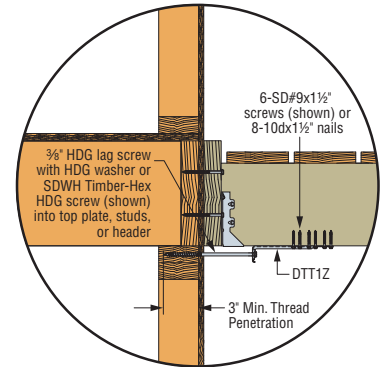

Typical DTT1Z Deck-to-House Lateral Load Connection
For more information on lateral load connections, see technical bulletin T-DECKLATLOAD

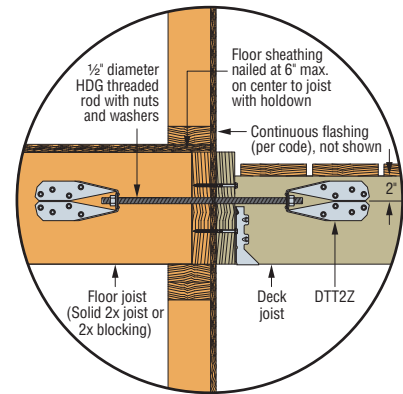

Typical DTT2Z Deck-to-House Lateral Load Connection
For more information on lateral load connections, see technical bulletin T-DECKLATLOAD

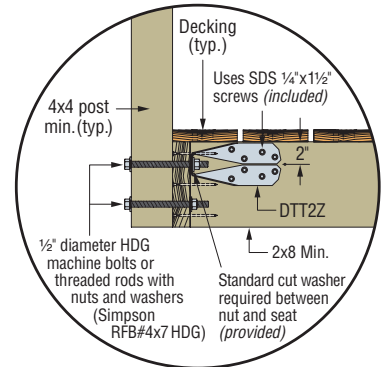

DTT2Z Installed as a Lateral Connector for a Deck Guardrail Post
For more information on guardrail post connections, see technical bulletin T-GRDRLPST

These products are available with additional corrosion protection. Additional products on this page may also be available with this option, check with Simpson Strong-Tie for details.

Model No.	C	Anchor Dia.	Fasteners	Minimum Wood Member Thickness	Allowable Tension Loads		Code Ref.
					DF/SP	SPF/HF	
DTT1Z	3/4	3/8 or SDWH ³	6-SD #9x1 1/2	1 1/2	840	840	160
			6-10dx1 1/2		910	640 ²	
			8-10dx1 1/2		910	850	
DTT2Z/DTT2SS	13/16	1/2	8-1/4"x1 1/2" SDS	1 1/2	1825	1800	16, L8, F5
				3	2145	1835	
DTT2Z-SDS2.5	13/16	1/2	8-1/4"x2 1/2" SDS	3	2145	2105	

1. Allowable loads have been increased 60% for wind or earthquake loading with no further increase allowed.
2. DTT1Z installations with allowable loads below 750 lbs. do not satisfy the 2015 IRC requirements for deck-to-house lateral load connections.
3. The Strong-Drive® SDWH Timber-Hex HDG screw with a minimum of 3" of thread penetration into dry lumber has an allowable withdrawal load (160) of 1380 lbs. into SP, 1225 lbs. into DF and 1020 lbs. into SPF/HF.
4. Load values are valid if the product is flush with the end of the framing member or installed away from the end.
5. The guardrail post illustration above addresses an outward force on the guardrail. An additional DTT2Z can be added at the lower bolt to address an inward force.
6. A 3/8" HDG round washer is required when using a lag screw.

STRONG-DRIVE® TIMBER Screws

The Strong-Drive® SDWS Timber screw is designed to provide an easy-to-install, high-strength alternative to through-bolting and traditional lag screws. The Strong-Drive SDWH Timber-Hex SS screw provides a structural wood-to-wood connection, including for ledgers. As a Type 316 stainless steel fasteners, the Strong-Drive SDWH Timber-Hex SS screw offers maximum corrosion protection.

MATERIAL: Strong-Drive SDWS Timber screw—heat-treated carbon steel, **Strong-Drive SDWH Timber-Hex SS screw—Type 316 stainless steel**

FINISH: Strong-Drive SDWS Timber screw—Double-barrier coating
INSTALLATION: • See General Notes.

- Strong-Drive SDWS Timber screws install best with a low-speed ½" drill and a T-40 6-lobe bit. The matched bit included with the screws is recommended for best results.
- **Strong-Drive SDWH Timber-Hex SS** screws install best with a low-speed ½" drill and a ⅝" hex driver bit. The matched bit included with the screws is recommended for best results.
- Pre-drilling is typically not required. Where pre-drilling is necessary, use a ⅝" drill bit for Strong-Drive SDWS Timber screws and **0.188" Strong-Drive SDWH Timber-Hex SS screws. Use a ⅜" drill bit for 0.276" Strong-Drive SDWH Timber-Hex SS screws.**
- Screw heads that are countersunk flush to the wood surface are acceptable if the screw has not spun out.
- For additional information, visit www.strongtie.com/fasteners.

CODES: See page 12 for Code Reference Key Chart.

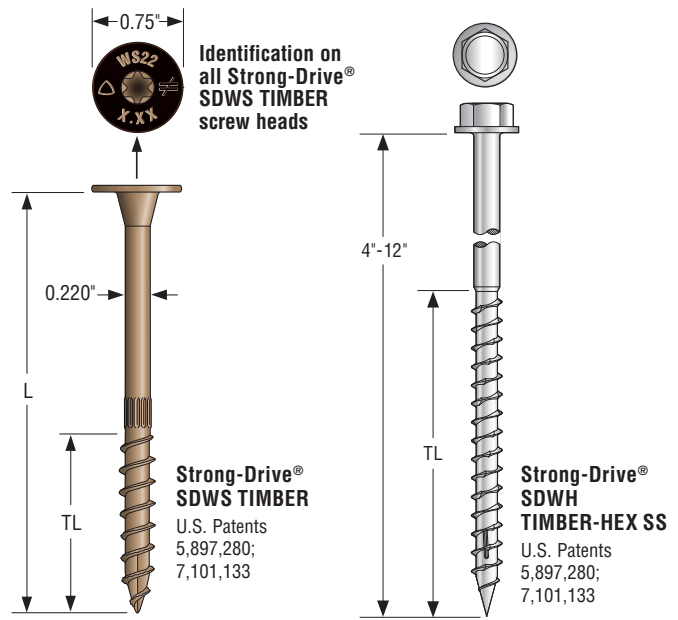

Strong-Drive® SDWS TIMBER Screw Product Information

Size Dia. x L (in.)	Thread Length TL (in.)	Retail Pack ¹			Mini-Bulk Bucket ¹			Bulk ¹	
		Fasteners Per Pack	Packs Per Master Carton	Model No.	Fasteners Per Pack	Packs Per Master Carton	Model No.	Fasteners Per Pack	Model No.
0.220 x 3	1½	12	10	SDWS22300DB-RC12	50	6	SDWS22300DB-R50	950	SDWS22300DB
0.220 x 4	2¾	12	10	SDWS22400DB-RC12	50	6	SDWS22400DB-R50	600	SDWS22400DB
0.220 x 5	2¾	12	10	SDWS22500DB-RC12	50	6	SDWS22500DB-R50	600	SDWS22500DB
0.220 x 6	2¾	12	10	SDWS22600DB-RC12	50	6	SDWS22600DB-R50	500	SDWS22600DB
0.220 x 8	2¾	12	10	SDWS22800DB-RC12	50	6	SDWS22800DB-R50	400	SDWS22800DB
0.220 x 10	2¾	12	10	SDWS221000DBRC12	50	6	SDWS221000DB-R50	250	SDWS221000DB

1. Retail and mini-bulk packs include one deep, 6-lobe, T-40 driver bit; bulk packs include two driver bits.

Strong-Drive® SDWH TIMBER-HEX SS Screw Product Information

Size (in.)	Hex Drive (in.)	Thread Length (in.)	Package		Bucket	
			Fasteners Per Pack	Model No.	Fasteners Per Bucket	Model No.
0.188 x 4	⅝	2.40	20	SDWH19400SS-R20	100	SDWH19400SS-R100
0.188 x 4.5	⅝	2.75	10	SDWH19450SS-R10	100	SDWH19450SS-R100
0.188 x 5	⅝	2.40	10	SDWH19500SS-R10	100	SDWH19500SS-R100
0.188 x 6	⅝	2.40	10	SDWH19600SS-R10	100	SDWH19600SS-R100
0.188 x 8	⅝	2.40	10	SDWH19800SS-R10	50	SDWH19800SS-R50
0.276 x 3	½	2.95	10	SDWH27300SS-R10	100	SDWH27300SS-R100
0.276 x 4	½	2.95	10	SDWH27400SS-R10	100	SDWH27400SS-R100
0.276 x 5	½	2.95	10	SDWH27500SS-R10	50	SDWH27500SS-R50
0.276 x 6	½	2.95	10	SDWH27600SS-R10	50	SDWH27600SS-R50
0.276 x 8	½	2.95	10	SDWH27800SS-R10	25	SDWH27800SS-R25
0.276 x 10	½	2.95	5	SDWH271000SS-R5	25	SDWH271000SS-R25
0.276 x 12	½	2.95	5	SDWH271200SS-R5	25	SDWH271200SS-R25

Strong-Drive® SDWS TIMBER Screw Allowable Shear Loads – Douglas Fir-Larch and Southern Pine

Size Dia. x L (in.)	Model No.	Thread Length TL (in.)	DF/SP Allowable Loads									Code Ref.
			Shear (100)									
			Wood Side Member Thickness (in.)									
1.5	2	2.5	3	3.5	4	4.5	6	8				
0.220 x 3	SDWS22300DB	1½	255	—	—	—	—	—	—	—	—	IP4, F32, L23
0.220 x 4	SDWS22400DB	2¾	405	405	305	—	—	—	—	—		
0.220 x 5	SDWS22500DB	2¾	405	405	360	360	325	—	—	—		
0.220 x 6	SDWS22600DB	2¾	405	405	405	405	365	365	355	—		
0.220 x 8	SDWS22800DB	2¾	405	405	405	405	395	395	395	395	—	
0.220 x 10	SDWS221000DB	2¾	405	405	405	405	395	395	395	395	395	

See footnotes on page 211.

STRONG-DRIVE® SDWS TIMBER Screws

Strong-Drive® SDWS TIMBER Screw Allowable Shear Loads – Spruce-Pine-Fir and Hem-Fir

Size Dia. x L (in.)	Model No.	Thread Length TL (in.)	SPF/HF Allowable Loads									Code Ref.
			Shear (100)									
			Wood Side Member Thickness (in.)									
			1.5	2	2.5	3	3.5	4	4.5	6	8	
0.220 x 3	SDWS22300DB	1½	190	—	—	—	—	—	—	—	—	IP4, F32, L23
0.220 x 4	SDWS22400DB	2%	385	285	215	—	—	—	—	—	—	
0.220 x 5	SDWS22500DB	2¾	405	290	290	290	195	—	—	—	—	
0.220 x 6	SDWS22600DB	2¾	405	365	365	365	310	310	210	—	—	
0.220 x 8	SDWS22800DB	2¾	405	365	365	365	310	310	280	280	—	
0.220 x 10	SDWS221000DB	2¾	405	365	365	365	310	310	280	280	280	

- All applications are based on full penetration into the main member. Full penetration is the screw length minus the side member thickness.
- Allowable loads are shown at the wood load duration factor of $C_D = 1.0$. Loads may be increased for load duration per the building code up to a $C_D = 1.6$. Tabulated values must be multiplied by all applicable adjustment factors per the NDS.
- Minimum fastener spacing requirements to achieve table loads: 6" end distance, 1¼" edge distance, ½" between staggered rows of fasteners, 4" between non-staggered rows of fasteners and 8" between fasteners in a row.
- For in-service moisture content greater than 19%, use $C_M = 0.7$.

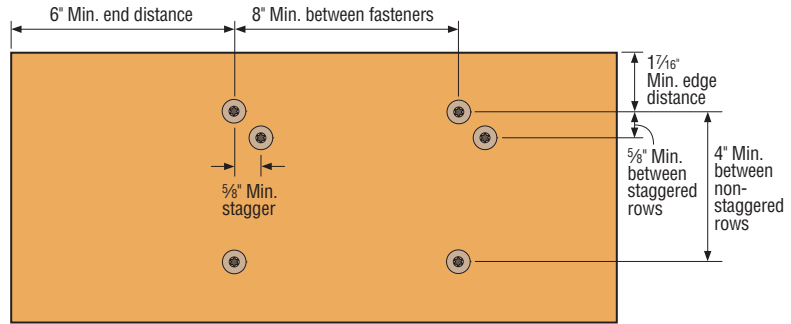

Strong-Drive® SDWS TIMBER Spacing Requirements

Strong-Drive® SDWH TIMBER-HEX SS Screw Allowable Shear Loads – Douglas Fir-Larch, Southern Pine, Spruce-Pine-Fir and Hem-Fir

Size (in.)	Model No.	Thread Length (in.)	Allowable Shear Loads			Code Ref.
			Wood Side Member Thickness (in.)			
			1½	3	3½	
0.188 x 4	SDWH19400SS-R100	2.40	177	—	—	IP4, F32
0.188 x 4½	SDWH19450SS-R100	2.75	177	177	—	
0.188 x 5	SDWH19500SS-R100	2.40	177	177	177	
0.188 x 6	SDWH19600SS-R100	2.40	177	177	177	
0.188 x 8	SDWH19800SS-R50	2.40	177	177	177	
0.276 x 4	SDWH27400SS-R100	2.95	235	—	—	
0.276 x 5	SDWH27500SS-R50	2.95	235	235	235	
0.276 x 6	SDWH27600SS-R50	2.95	235	235	235	
0.276 x 8	SDWH27800SS-R25	2.95	235	235	235	
0.276 x 10	SDWH271000SS-R25	2.95	235	235	235	
0.276 x 12	SDWH271200SS-R25	2.95	235	235	235	

- All applications are based on full penetration into the main member. Full penetration is the screw length minus the side member thickness.
- Allowable loads are shown at the load duration factor of $C_D = 1.0$. Loads may be increased for load duration per the building code up to a $C_D = 1.6$. Tabulated values must be multiplied by all applicable adjustment factors per the NDS.
- Table values based on testing in SPF lumber.
- Minimum fastener spacing requirements: 3" end distance, 1¼" edge distance, 1½" between staggered rows of fasteners, 3" between non-staggered rows of fasteners and 3" between fasteners in a row.
- Design values include NDS wet service factor; no adjustment required for in-service moisture content greater than 19%.
- Allowable loads are perpendicular or parallel to grain.
- Installs best with 18v high-torque cordless or ½" low speed drill. If splitting occurs predrill with ⅜" drill bit for 0.188" screws and 7/32" drill bit for 0.276" screws.
- Allowable withdrawal load for the 0.188" screw for DF/SP is 155 lbs./in. and for SPF/HF is 108 lbs./in. Allowable load is based on inches of thread penetration into the main member.
- Allowable withdrawal load for the 0.276" screw for DF/SP is 260 lbs./in. and for SPF/HF is 160 lbs./in. Allowable load is based on inches of thread penetration into the main member.
- For LRFD values, the reference connection design values shall be adjusted in accordance with NDS-12, section 10.3.

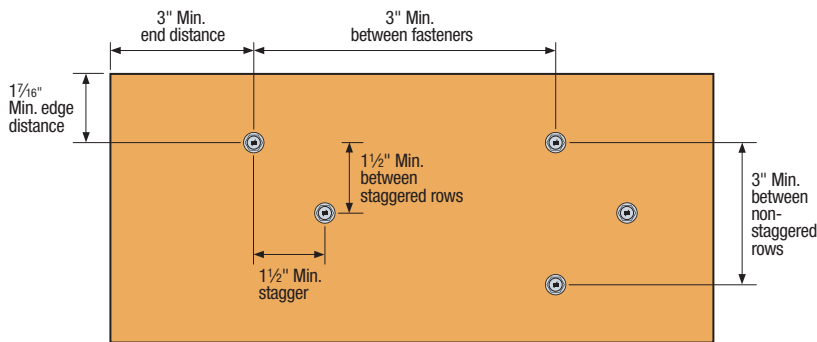

Strong-Drive® SDWH TIMBER-HEX SS Screw Spacing Requirements

STRONG-DRIVE® SDWS TIMBER Screws

Strong-Drive® SDWS TIMBER Screw – Douglas Fir-Larch, Southern Pine, Spruce Pine Fir and Hem Fir Lumber Allowable Withdrawal Loads

Model No.	Fastener Length, L (in.)	Thread Length, TL (in.)	Reference Withdrawal Design Value, W (lbs./inch)		Max. Reference Withdrawal Design Value, W _{Max}		Code Ref.
			DF and SP Main Member	HF and SPF Main Member	DF and SP Main Member	HF and SPF Main Member	
SDWS22300DB	3	1½	164	151	245	225	IP4, F32, L23
SDWS22400DB	4	2¾	179	160	425	380	
SDWS22500DB	5	2¾	214	187	590	495	
SDWS22600DB	6	2¾	214	187	590	495	
SDWS22800DB	8	2¾	214	187	590	495	
SDWS221000DB	10	2¾	214	187	590	495	

1. The tabulated reference withdrawal design value, W, is in pounds per inch of the thread penetration into the side grain of the main member.
2. The tabulated reference withdrawal design value, W_{Max}, is in pounds where the entire thread length must penetrate into the side grain of the main member.
3. Tabulated reference withdrawal design values, W and W_{Max}, are shown at a C_D = 1.0. Loads may be increased for load duration per the building code up to a C_D = 1.6. Tabulated values must be multiplied by all applicable adjustment factors from the NDS as referenced in the IBC or IRC.
4. Embedded thread length is that portion held in the main member including the screw tip.
5. Values are based on the lesser of withdrawal from the main member or pull-through of a 1½" side member.
6. For in-service moisture content greater than 19%, use C_M = 0.7.

Strong-Drive® SDWS TIMBER Screw – 2009 and 2012 IRC Compliant Spacing for a Sawn Lumber Deck Ledger to Band Joist

Loading Condition	Nominal Ledger Size	Screw Model No.	Band Joist Material and Minimum Size	Maximum Deck Joist Span						
				Up to 6 ft.	Up to 8 ft.	Up to 10 ft.	Up to 12 ft.	Up to 14 ft.	Up to 16 ft.	Up to 18 ft.
				Maximum On-Center Spacing of Fasteners (in.)						
40 psf Live 10 psf Dead	2x	SDWS22400DB	1" OSB	14	10	8	7	6	5	5
			1" LVL							
			1½" OSB	16	12	10	8	7	6	5
			1½" LVL							
			1¼" LSL							
2x SP, DF – 2x SPF, HF	22	16	13	11	9	8	7			
60 psf Live 10 psf Dead	2x	SDWS22400DB	1" OSB	10	7	6	5	4	4	3
			1" LVL							
			1½" OSB	12	9	7	6	5	4	4
			1½" LVL							
			1¼" LSL							
2x SP, DF – 2x SPF, HF	15	12	9	8	7	6	5			
40 psf Live 10 psf Dead	2-2x	SDWS22500DB	1" OSB	15	12	9	8	7	6	5
			1" LVL							
			1½" OSB	16	12	10	8	7	6	5
			1½" LVL							
			1¼" LSL							
2x SP, DF – 2x SPF, HF	16	12	10	8	7	6	5			
60 psf Live 10 psf Dead	2-2x	SDWS22500DB	1" OSB	11	8	7	6	5	4	4
			1" LVL							
			1½" OSB	12	9	7	6	5	4	4
			1½" LVL							
			1¼" LSL							
2x SP, DF – 2x SPF, HF	12	9	7	6	5	4	4			

1. Strong-Drive® SDWS Timber screw spacing values are equivalent to 2009 IRC Table R502.2.2.1. The table above also provides Strong-Drive SDWS Timber screw spacing for a wider range of materials commonly used for band joists, and an alternate loading condition as required by some jurisdictions.
2. Solid-sawn band joists shall be Spruce-Pine-Fir, Hem-Fir, Douglas Fir-Larch, or Southern Pine species. Ledger shall be Hem-Fir, Douglas Fir-Larch, or Southern Pine species.
3. Fastener spacings are based on the lesser of single fastener ICC-ES AC233 testing of the Strong-Drive SDWS Timber screw with a safety factor of 5.0 or ICC-ES AC13 ledger

- assembly testing with a factor of safety of 5.0. Spacing includes NDS wet service factor adjustment.
4. Multiple ledger plies shall be fastened together per code independent of the Strong-Drive SDWS Timber screws.
5. Screws shall be placed at least 1½" from the top or bottom of the ledger or band joist, 6" from the end of the ledger with 3" between rows and spaced per the table. See figure below.
6. Structural sheathing between the ledger and band shall be a maximum of ½" thick and fastened per code.

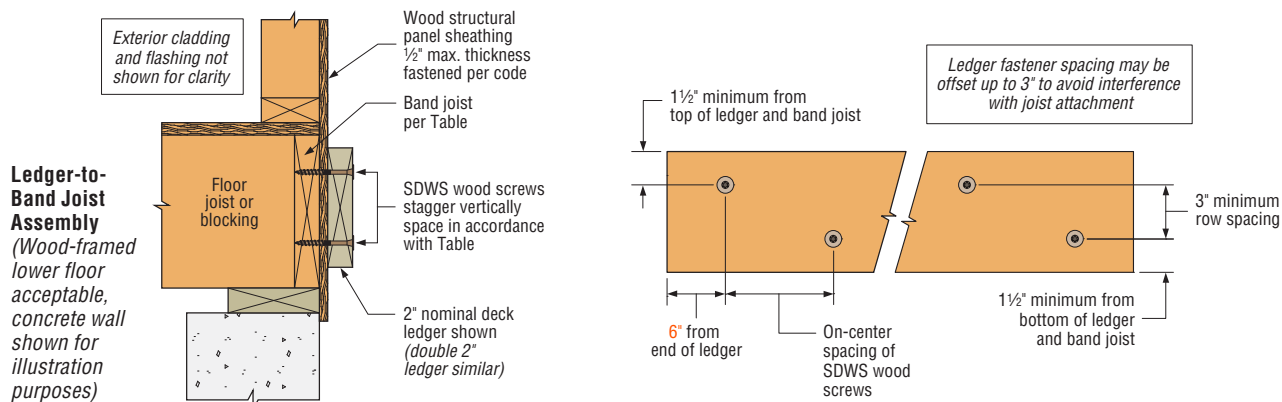

STRONG-DRIVE® SDWS TIMBER Screws

**Strong-Drive® SDWH TIMBER-HEX SS Screw –
2009 and 2012 IRC Compliant Spacing for a Sawn Lumber Deck Ledger to Band Joist**

0.276" Screws

Loading Condition	Ledger Size	Screw Length and Model No.	Band Joist Material and Size	Maximum Deck Joist Span						
				Up to 6 ft.	Up to 8 ft.	Up to 10 ft.	Up to 12 ft.	Up to 14 ft.	Up to 16 ft.	Up to 18 ft.
				Maximum On-Center Spacing of Fasteners (in.)						
40 psf Live 10 psf Dead	2x	4" SDWH27400SS	1" OSB	19	14	11	9	8	7	6
			1" LVL							
			1 1/8" OSB							
			1 1/8" LVL							
			1 1/4" OSB							
			1 1/2" LVL							
			1 1/4" LSL							
			1 3/4" LVL							
60 psf Live 10 psf Dead	2x	4" SDWH27400SS	1" OSB	13	10	8	7	6	5	4
			1" LVL							
			1 1/8" OSB							
			1 1/8" LVL							
			1 1/4" OSB							
			1 1/2" LVL							
			1 1/4" LSL							
			1 3/4" LVL							
40 psf Live 10 psf Dead	2-2x	5" SDWH27500SS	1" OSB	19	14	11	9	8	7	6
			1" LVL							
			1 1/8" OSB							
			1 1/8" LVL							
			1 1/4" OSB							
			1 1/2" LVL							
			1 1/4" LSL							
			1 3/4" LVL							
60 psf Live 10 psf Dead	2-2x	5" SDWH27500SS	1" OSB	13	10	8	7	6	5	4
			1" LVL							
			1 1/8" OSB							
			1 1/8" LVL							
			1 1/4" OSB							
			1 1/2" LVL							
			1 1/4" LSL							
			1 3/4" LVL							
40 psf Live 10 psf Dead	2-2x	5" SDWH27500SS	2x SP, DFL, SPF, HF	19	14	11	9	8	7	6
			1" OSB							
			1" LVL							
			1 1/8" OSB							
			1 1/8" LVL							
			1 1/4" OSB							
			1 1/2" LVL							
			1 1/4" LSL							
1 3/4" LVL										
60 psf Live 10 psf Dead	2-2x	5" SDWH27500SS	2x SP, DFL, SPF, HF	13	10	8	7	6	5	4
			1" OSB							
			1" LVL							
			1 1/8" OSB							
			1 1/8" LVL							
			1 1/4" OSB							
			1 1/2" LVL							
			1 1/4" LSL							
1 3/4" LVL										

See footnotes on page 214.

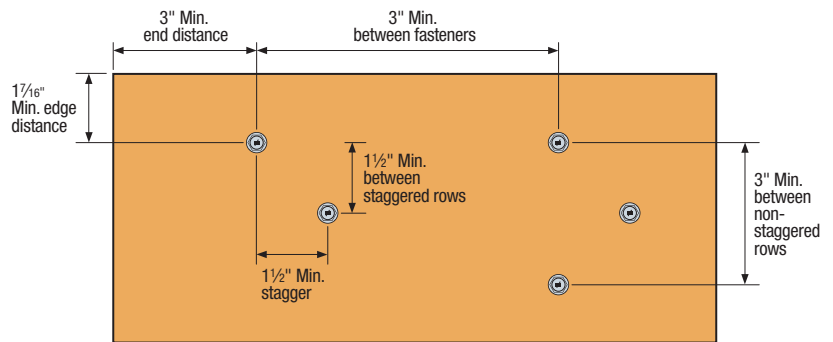
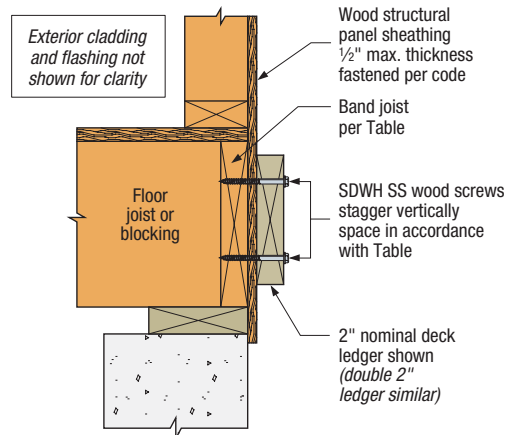

**Strong-Drive® SDWH TIMBER-HEX SS Screw
Spacing Requirements**

Ledger-to-Band Joist Assembly
(Wood-framed lower floor acceptable,
concrete wall shown for illustration purposes)

LSC Adjustable Stringer Connector

The LSC adjustable stair-stringer connector offers a versatile, concealed connection between the stair stringer and the carrying header or rim joist while replacing costly framing. Field slopeable to all common stair stringer pitches, the LSC connector is suitable for either solid or notched stringers.

Features:

- Replaces additional framing and toe-nailing
- Suitable for most installations on 2x10 or 2x12 header/rim joist
- May be installed flush with the top of the carrying member or lower on the face
- Interchangeable for left or right applications
- LSCZ features a ZMAX® coating for additional corrosion protection. Suitable for interior and some exterior applications. LSCSS is made from stainless steel for higher exposure environment. See www.strongtie.com/info for more information

MATERIAL: 18 gauge

FINISH: LSCZ—ZMAX® coating; LSCSS—Stainless steel

INSTALLATION: • Use all specified fasteners, see table.

- Before fastening, position the stair stringer with the LSC on the carrying member to verify where the bend should be located.
- Tabs on the LSC must be positioned to the inside of the stairs.
- The fastener that is installed into the bottom edge of the stringer must go into the second-to-last hole.
- When installed on 1 5/16" LVL or a 1 1/4" LSL stringer, additional items that will not affect the structural performance of the LSC, but should be considered, include the following:
 - LSC stringer flange will protrude 3/4" from face of stringer. As such, it is recommended the LSC be installed with the tabs positioned to the outside of the stringer.
 - 1 1/2" fasteners installed into 1 1/4" LSL stringer will protrude from the opposite side.

CODES: See page 12 for Code Reference Key Chart.

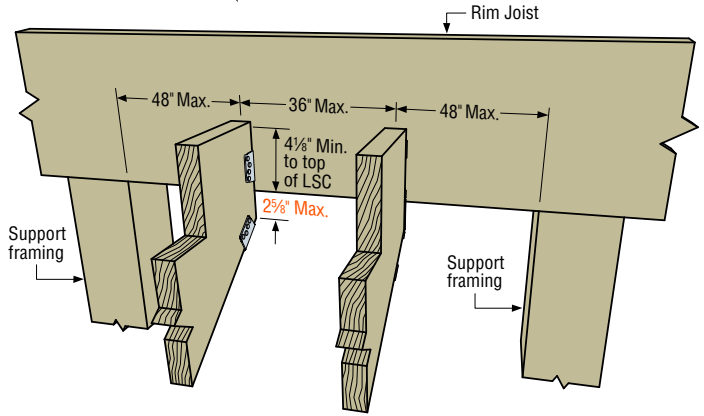
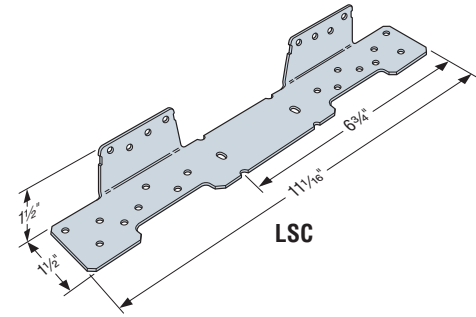

Standard LSC Installation

These products feature additional corrosion protection.

These products are approved for installation with the Strong-Drive® SD Connector screw. See page 27 for more information.

Model No.	Rim Joist Installation	Fastener Schedule			DF/SP Allowable Loads		SPF/HF Allowable Loads		Code Ref.
		Rim Joist ²	Stringer Wide Face	Stringer Narrow Face	Floor (100)	Snow (115)	Floor (100)	Snow (115)	
LSCZ LSCSS	Supported ⁴	8-10dx1 1/2"	8-10dx1 1/2"	1-10dx1 1/2"	950	1000	815	860	I18, L26
	Supported	8-SD #9x1 1/2"	8-SD #9x1 1/2"	—	865	865	670	670	
	Standard	8-10dx1 1/2"	8-10dx1 1/2"	1-10dx1 1/2"	755	755	650	650	
	Standard	8-SD #9x1 1/2"	8-SD #9x1 1/2"	1-SD #9x1 1/2"	755	755	650	650	
	Cantilever	8-10dx1 1/2"	8-10dx1 1/2"	1-10dx1 1/2"	520	520	445	445	
	Cantilever	8-SD #9x1 1/2"	8-SD #9x1 1/2"	—	545	545	445	445	

1. Stair stringer must be minimum 1 5/16" LVL or minimum 1 1/4" LSL. Allowable loads for DF/SP species material shall apply.
2. When cross-grain tension forces cannot be avoided in the members, mechanical reinforcement to resist such forces may be considered.
3. A minimum distance of 3/4" measured from the lowest rim-joist fastener to edge of rim joist is required.
4. Simpson Strong-Tie® #9x1 1/2" Strong-Drive SD Connector screws may be substituted for 10dx1 1/2" nails to achieve published nail values if the extra screw is installed in the narrow face of stringer.
5. **NAIL:** 10dx1 1/2" = 0.148" dia. x 1 1/2" long. Nails shall be hot-dip galvanized for LSCZ and stainless steel for LSCSS. See pages 22-23 for other nail sizes and information.
6. **SCREWS (LSCZ only):** SD #9x1 1/2" (model SD9112) = 0.131" dia. x 1 1/2" long (see page 27).

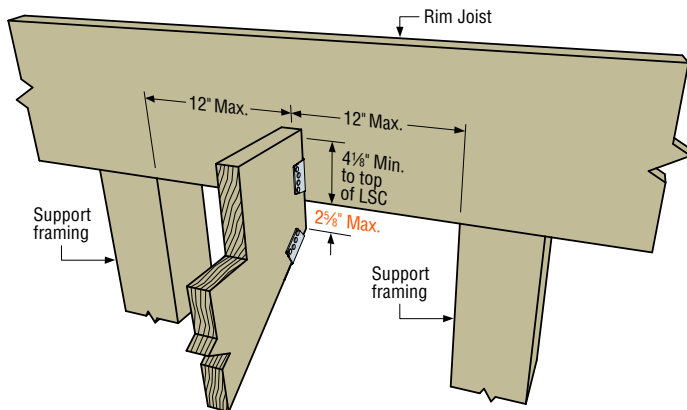

Supported LSC Installation

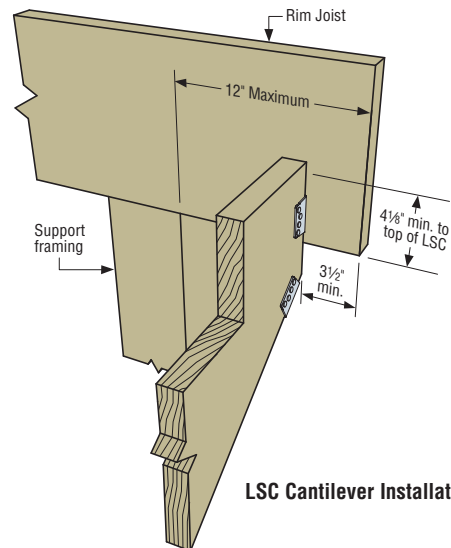

LSC Cantilever Installation

DJT14Z Deck Joist Tie

The DJT14Z Deck Joist Tie is designed to attach 2x deck joists to the side of 4x or larger support posts. The DJT14Z can be installed with either nails or bolts.

MATERIAL: 14 gauge

FINISH: ZMAX® coating; see Corrosion Information, pages 13-15.

INSTALLATION: • Use specified HDG fasteners. See General Notes.

- Recommended: install on post first.
- Minimum 2x4 joist and 4x4 post.

CODES: See page 12 for Code Reference Key Chart.

These products are available with additional corrosion protection. Additional products on this page may also be available with this option, check with Simpson Strong-Tie for details.

These products are approved for installation with the Strong-Drive® SD Connector screw. See page 27 for more information.

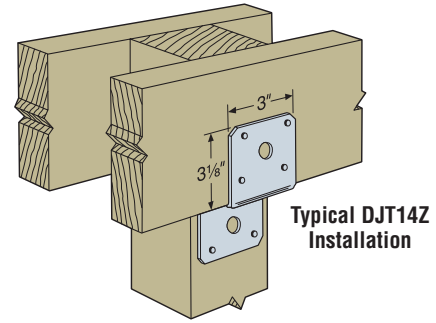

Typical DJT14Z Installation

Model No.	Fasteners		Allowable Loads				Code Ref.	
	Nails	Bolts	Nails		Bolts			
			Floor (100)	Roof (125)	Floor (100)	Roof (125)		
DJT14Z	8-16d	2	5/8 MB	1160	1400	1220	1400	I18, F17, L5, L13

1. Loads are for one DJT14Z.
2. Roof loads are 125% of floor loads. Floor loads may be adjusted for other load durations according to the code, provided they do not exceed the roof loads.
3. **NAILS:** 16d = 0.162" dia. x 3 1/2" long. See pages 22-23 for other nail sizes and information.

TA Staircase Angles

For use in structurally-sound staircase framing. The TA eliminates costly conventional notching.

MATERIAL: 12 gauge

FINISH: TA9Z/TA10Z—ZMAX coating; TA9SS/TA10SS—stainless steel; see Corrosion Information, pages 13-15.

ORDER: May be ordered as kits with model numbers TA9ZKT and TA10ZKT. Each kit includes two ZMAX TA's and Simpson Strong-Tie® 1/4"x1 1/2" Strong-Drive® SDS Heavy-Duty Connector screws.

CODES: See page 12 for Code Reference Key Chart.

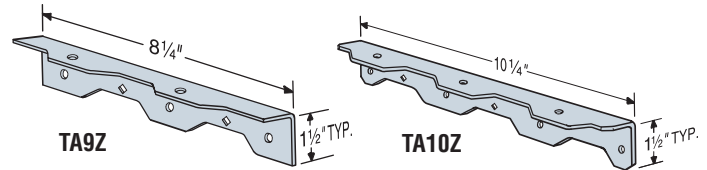

TA9Z

TA10Z

These products are available with additional corrosion protection. Additional products on this page may also be available with this option, check with Simpson Strong-Tie for details.

Model No.	Fasteners		Allowable Downloads DF/SP (100)	Code Ref.
	Stringer	Tread		
TA9Z	3-SDS 1/4"x1 1/2"	2-SDS 1/4"x1 1/2"	750	170
TA10Z	3-SDS 1/4"x1 1/2"	4-SDS 1/4"x1 1/2"	750	
TA10Z	4-SDS 1/4"x1 1/2"	3-SDS 1/4"x1 1/2"	1000	

1. Loads may be adjusted for other load durations according to the code.
2. See page 26 for Strong-Drive SDS Heavy-Duty Connector screw information.

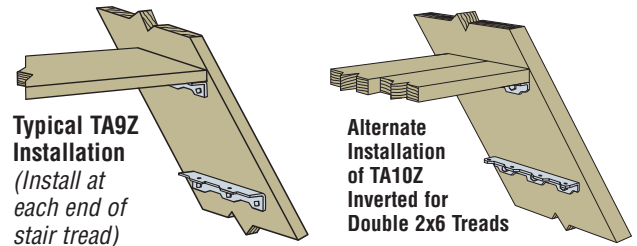

Typical TA9Z Installation (Install at each end of stair tread)

Alternate Installation of TA10Z Inverted for Double 2x6 Treads

ML24/ML26 Angles

The ML angle combines strength and versatility through the use of Simpson Strong-Tie® Strong-Drive® SDS Heavy-Duty Connector screws. Fastener holes are staggered to minimize wood splitting and opposing hole patterns allows for back to back installation without fastener interference.

MATERIAL: 12 gauge

FINISH: ML24Z/ML26Z—ZMAX® coating; ML24SS/ML26SS—stainless steel; see Corrosion Information, pages 13-15.

INSTALLATION: • Use all specified fasteners. See General Notes.

- Simpson Strong-Tie 1/4"x1 1/2" Strong-Drive SDS Heavy-Duty Connector screws are not provided with the angle.

CODES: See page 12 for Code Reference Key Chart.

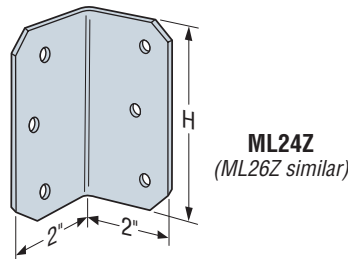

ML24Z (ML26Z similar)

These products are available with additional corrosion protection. Additional products on this page may also be available with this option, check with Simpson Strong-Tie for details.

Model No.	H	Fasteners (Total)	DF/SP Allowable Loads				SPF/HF Allowable Loads				Code Ref.
			(100)	(115)	(125)	(160)	(100)	(115)	(125)	(160)	
ML24Z	4	6-SDS 1/4"x1 1/2"	515	515	515	515	440	440	440	440	F24
ML26Z	6	8-SDS 1/4"x1 1/2"	1000	1050	1090	1090	720	830	900	935	

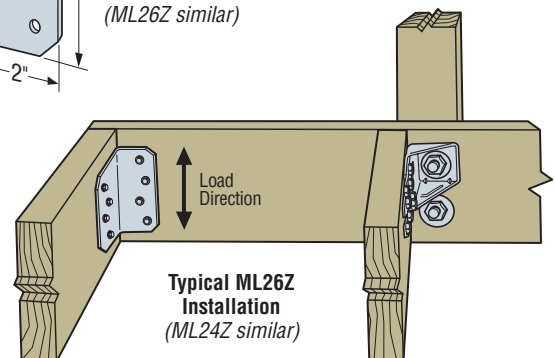

Typical ML26Z Installation (ML24Z similar)

KBS1Z Knee-Brace Stabilizer

The KBS1Z knee-brace stabilizer makes a structural connection between knee bracing and columns or beams to help stabilize free-standing structures and comply with many prescriptive deck bracing requirements such as AWC's DCA6 Prescriptive Residential Wood Deck Construction Guide. Factory-formed at a 45° angle and easily installed with nails, the KBS1Z braces 2x, 4x and 6x in line post-to-beam configurations. Check with your local building department for deck bracing requirements.

MATERIAL: 16 gauge

FINISH: ZMAX® coating

INSTALLATION:

- Use all specified fasteners. See General Notes.
- For installations at an angle other than 45°, bend KBS1Z along slots to desired angle. Bend one time only.
- Knee Brace:
 - Cut braces at desired angle
 - Bend KBS1Z to desired angle if required
 - Install fasteners to secure in place
 - For equal-width members, install (2) KBS1Z on each end of brace (see connection type 1)
 - For 2x knee brace, install single KBS1Z on each end of brace (see connection type 2)
- Beam-to-Post: Install in pairs. See illustrations for quantity and configuration.

CODES: See page 12 for Code Reference Key Chart.

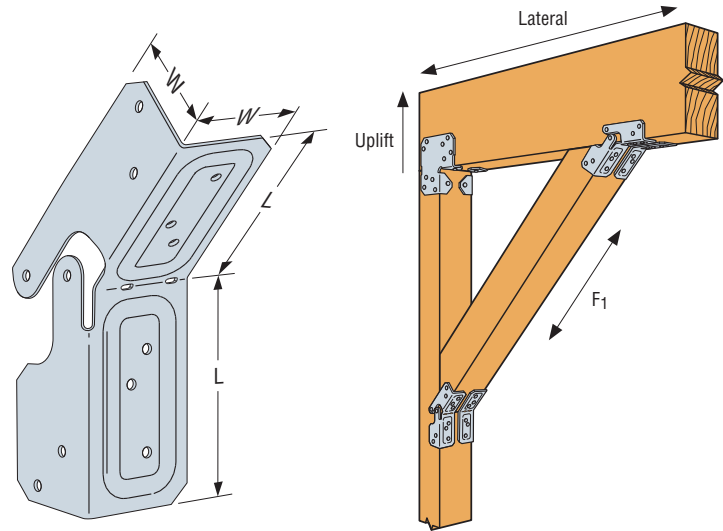

KBS1Z
(Patent Pending)

1 Post-to-Knee Brace Connection
(Same member width)

These products are available with additional corrosion protection. Additional products on this page may also be available with this option, check with Simpson Strong-Tie for details.

These products are approved for installation with the Strong-Drive® SD Connector screw. See page 27 for more information.

Model	Dimensions (in.)		Type of Connection	Connectors per Joint	Fasteners Each Connector ¹	Direction of Load	Allowable Loads ² (160)				Code Ref.
	W	L					In-Service Moisture Content				
							≤ 19%		> 19%		
DF/SP	SPF/HF	DF/SP	SPF/HF								
KBS1Z	1½	3	1	2	12-8d	F ₁ Brace angle = 45°	1175	1010	1055	860	160
						F ₁ Brace angle = 30° or 60° ³	835	720	835	720	
			2	1	12-8dx1½	F ₁ Brace angle = 45°	630	540	470	385	
						F ₁ Brace angle = 30° or 60° ³	510	440	395	330	
			3	4	12-8d	Uplift	1160	1000	1160	1000	
						Lateral	1725	1480	1725	1480	
			4	2	12-8d	Uplift	540	465	540	465	
						Lateral	485	420	430	370	
				4		Uplift	900	775	900	775	
						Lateral	1270	1095	1270	1095	

1. SD9x1½ screws may be substituted for the specified fasteners with no load reduction.
2. Allowable loads have been increased for wind or earthquake with no further increase allowed; reduce where other loads govern.
3. For braces installed at intermediate angles, allowable loads may be interpolated between loads listed for brace angle = 45° and brace angle = 30° or 60°.

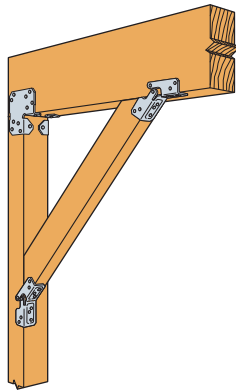

2 Post-to-2x Knee Brace Connection

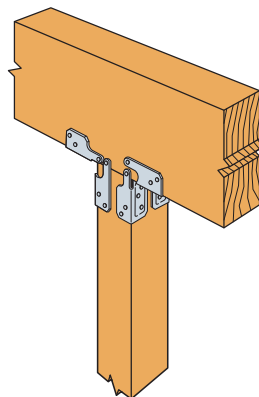

3 (Continuous) Beam-to-Post

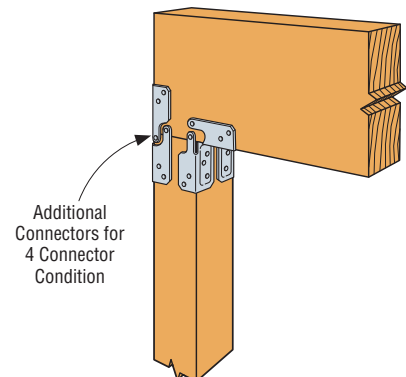

4 End Beam-to-Post

PGT[®] Pipe Grip Ties[®]

Pipe Grip Ties attach wood fence rails to metal fence posts, eliminating rotted and failed wood posts. The PGT is suitable for standard applications as well as corners and splices.

The PGTIC2Z-R is an interior corner pipe grip tie.

The PGT1.5Z-R is for 1½" pipe (1⅞" outside diameter), and the PGT2Z-R is for 2" pipe (2⅜" outside diameter).

The PGT2A is for 2" pipe (2⅜" outside diameter).

MATERIAL: PGT2A—14 gauge; all others 12 gauge

FINISH: PGTA, PGT2-R – Galvanized

PGTIC2Z, PGT1.5Z, PGT2Z-R – ZMAX[®]

INSTALLATION: • Use all specified fasteners.

See General Notes.

- PGTIC2Z-R to Post – Install two set screws (supplied) with ⅜" socket in predrilled holes.
- PGTIC2Z-R to Rails – Use Simpson Strong-Tie[®] ¼" x 1½" Strong-Drive[®] SDS Heavy-Duty Connector screws (not supplied).
- Install on vertical pipes, offsetting corners to allow for the correct rail alignment.
- Use 3 to 4 PGTs per pipe; line up to stringline.
- Fasten PGT with ¼" hex head bolt (supplied).
- PGT attaches to rails with four Simpson Strong-Tie ¼" x 1½" Strong-Drive SDS Heavy-Duty Connector screws (not supplied). See page 26 for Strong-Drive SDS Heavy-Duty Connector screw information.
- ¼" lag bolts may be used. Follow the code requirements for predrilling.
- Nail or screw fence boards to rails.
- Field bend PGT flanges to fit corner and angled conditions (bend one time only).

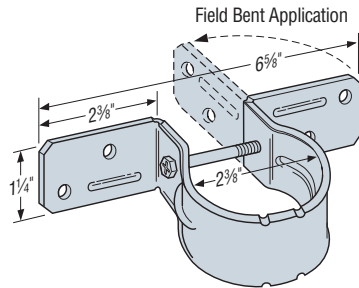

PGT2A

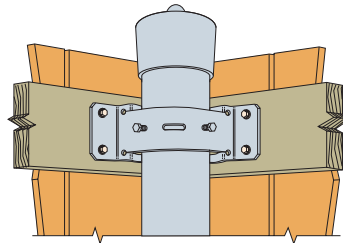

Typical PGTIC2Z-R Fence Installation

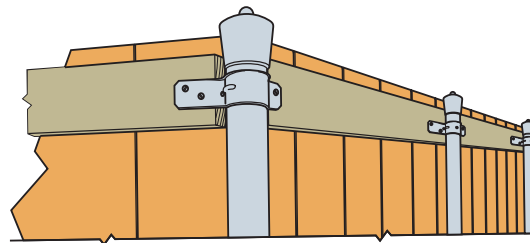

Typical PGT2Z-R Fence Installation

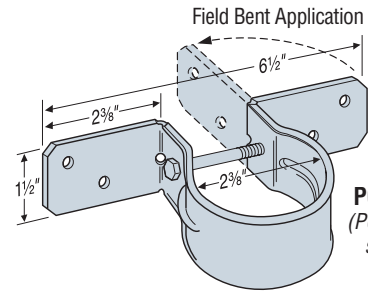
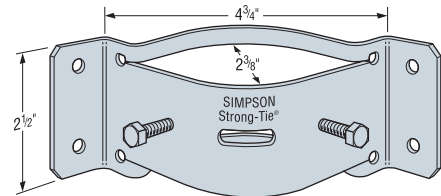
PGT2Z-R
(PGT1.5Z-R similar)

PGTIC2Z-R

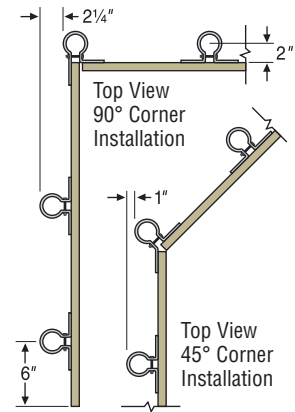

Corner Installation Top View

PGT2E Pipe-Grip Tie

Simpson Strong-Tie introduces the latest time-saving solution for building fences with 2" steel posts. The PGT2E pipe-grip tie features a unique two-piece design that installs quickly and provides a solid connection between fence stringer and post. Snap the attachment plate onto the post for easy positioning and secure the strap using one thread-tapping screw (included).

- Faster to install than other two-piece fence-post brackets
- Safer to use, eliminating protruding carriage bolts and sharp corners
- Unique locking tab for the strap means only one screw is needed to fasten

MATERIAL: 12 gauge **FINISH:** Galvanized

INSTALLATION:

- Fasten two rails using ¼" Simpson Strong-Tie[®] Strong-Drive[®] SDS Heavy-Duty Connector screws or ¼" lag screws (follow code requirements for pre-drilling). See page 26 for Strong-Drive SDS Heavy-Duty Connector screw information.
- PGT2E-R50: Sold as full carton with (50) attachment plates, (50) front straps and (55) thread-tapping screws.

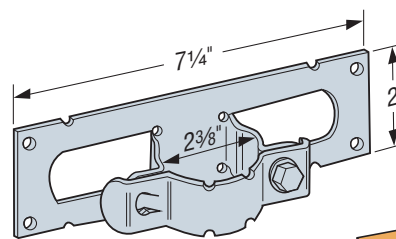

PGT2E

U.S. Patent 8,220,781

Typical PGT2E Installation

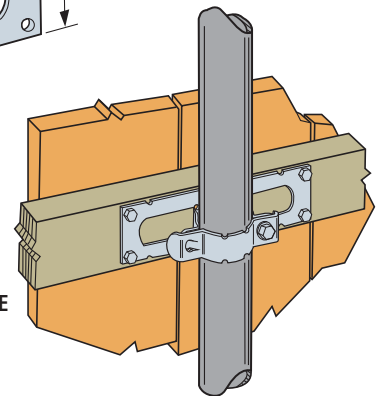

FB/FBR Fence Brackets

FB and FBR fence brackets make the connection between fence rails and posts simple and strong. Eliminates the need for toe nailing or screwing. Clean, versatile connections make planning and building fences, deck/porch railings and louvers easier and faster.

MATERIAL: See table

FINISH: FB/FBR—Galvanized; **FB24SS**—stainless steel. Some products available in ZMAX® coating; see Corrosion Information, pages 13-15.

- INSTALLATION:**
- Holes are sized for 8dx1½", 8d commons or Simpson Strong-Tie® 9x1½" Strong-Drive SD Connector screws into the supporting member.
 - FB24R is sized for 10dx1½" or **Simpson Strong-Tie 9x1½" Strong-Drive SD Connector** screws.
 - FB26 is sized for **Simpson Strong-Tie 9x1½" Strong-Drive SD Connector** screws.

CODES: See page 12 for Code Reference Key Chart.

These products are available with additional corrosion protection. Additional products on this page may also be available with this option, check with Simpson Strong-Tie for details.

These products are approved for installation with the Strong-Drive® SD Connector screw. See page 27 for more information.

Model No.	Ga	Member Size	Dimensions			Code Ref.
			W	H	B	
FB24Z	20	2x4	1⅞	3⅞	¾	180
FB24R	20	2x4 RGH	2	3⅞	¾	
FBR24	18	2x4	1⅞	2⅞	1½	
FB26	18	2x6	1⅞	5	1½	

1. FB26 has an allowable load for F₁ of 365 lbs.
2. FBR24: R = rail (not rough).
3. **NAILS:** 10dx1½" = 0.148" dia. x 1½" long, 8d = 0.131" dia. x 2½" long, 8dx1½" = 0.131" dia. x 1½" long. See pages 22-23 for other nail sizes and information.

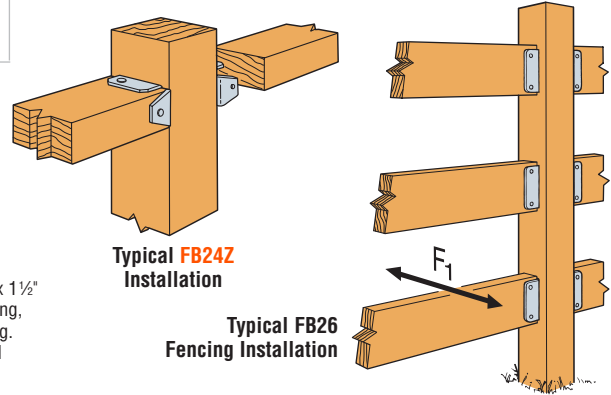
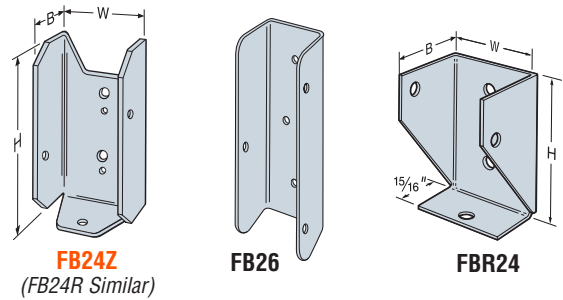

E-Z Base™/E-Z Mender™/E-Z Spike™ Fence Products

Replacing an entire fence can be an expensive and difficult task. Simpson Strong-Tie® offers a line of products designed to help make reinforcing fence posts easy and economical. The E-Z Base, E-Z Mender and E-Z Spike offer simple solutions for all types of fence post projects.

E-Z Spike (Model No. FPBS44)

- Allows easy installation of 4x4 wood posts without digging holes or pouring concrete.
- Can be used for a variety of applications where quick-to-install posts are needed.

E-Z Mender (Model No. FPBM44E)

- Allows easy repair of rotted or damaged 4x4 wood posts installed in concrete or dirt.
- Reinforces weakened wood posts without having to replace the post or the concrete.
- Sold individually. Use in pairs.

E-Z Base (Model No. FPBB44)

- Allows easy installation of 4x4 wood posts on existing concrete.

MATERIAL: 12 gauge

FINISH: Black powder-coat

INSTALLATION:

- See flier F-EZFPP.
- Attach post to E-Z Spike or E-Z Base with 8-¼" Strong-Drive SDS Heavy-Duty Connector screws or ¼" HDG lag screws and attach post to E-Z Mender using 6 HDG nails or screws per part.

NOTE: • Notwithstanding the terms of the Limited Warranty, Simpson Strong-Tie does not guarantee, represent or warrant that this product will perform under, or prevent or reduce damage caused by corrosion, any seismic, wind, atmospheric, or other load-producing event.

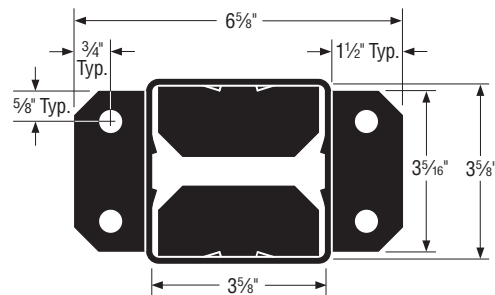
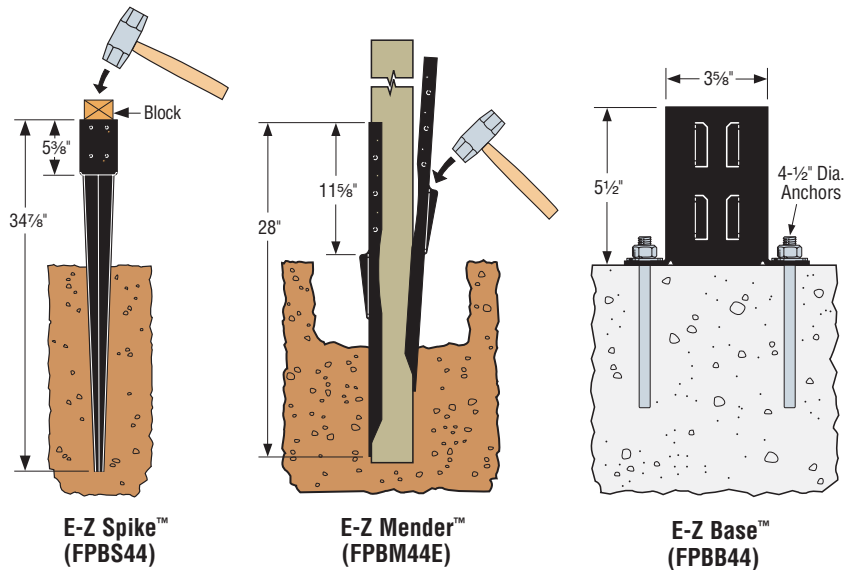

E-Z Base™ (FPBB44) Top View

RR Ridge Rafter Connector

An interlock provides alignment control and correct nailing locations. For a rafter-to-face connector, flatten the top flange into the face plane. The RR may be used with rafters sloped up to 30°.

MATERIAL: 18 gauge **FINISH:** Galvanized
INSTALLATION: • Use all specified fasteners. See General Notes.
CODES: See page 12 for Code Reference Key Chart.

These products are approved for installation with the Strong-Drive® SD Connector screw. See page 27 for more information.

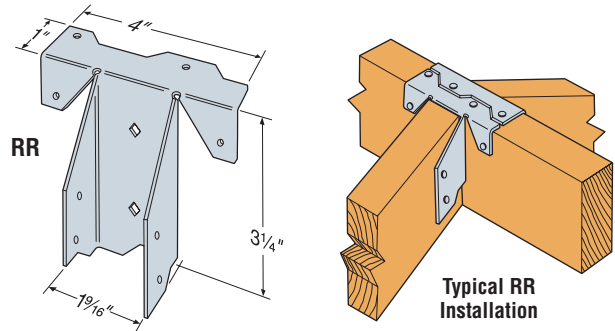

Model No.	Min. Rafter Size	Fasteners		Uplift (160)	Allowable Loads ¹		Code Ref.
		Header	Rafter		DF/SP		
					Floor (100)	Roof (125)	
RR	2x6	4-10dx1 1/2"	4-10dx1 1/2"	130	365	415	I10, L5, L11, F9

1. Floor loads may be adjusted for other load durations according to the code, provided they do not exceed the table roof loads.
2. **NAILS:** 10dx1 1/2" = 0.148" dia. x 1 1/2" long. See pages 22-23 for other nail sizes and information.

PSCL/PSCA Panel Sheathing Clips

Simpson Strong-Tie® Panel Sheathing Clips are used to brace unsupported sheathing edges. The PSCA is a new version of the PSCL with less material for a more cost effective solution. Model sizes include: PSCL 3/8", PSCA 7/16", PSCL 7/16", PSCA 15/32", PSCL 15/32", PSCL 1/2", PSCL 5/8"; PSCL 19/32", PSCL 3/4".

MATERIAL: 20 gauge **FINISH:** Galvanized
INSTALLATION: • Use the same size sheathing clip as the panel thickness.
• Maximum spans may be reduced for low slopes or high uniform loads, refer to manufacturer's installation instructions.

CODES: See page 12 for Code Reference Key Chart.

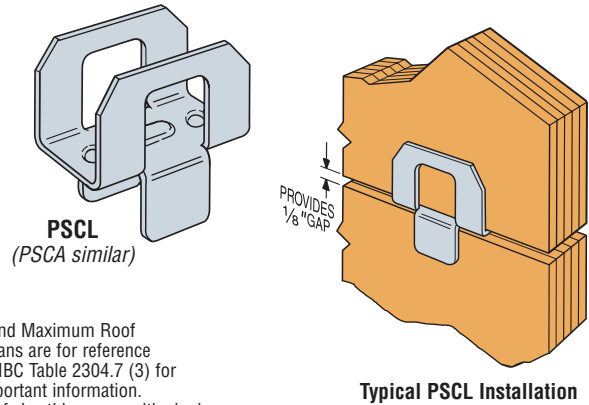

Span Rating	Panel Thickness	Maximum Roof Sheathing Span		No. of Clips Per Span	Code Ref.
		With Clip	Without Clip		
24/0	3/8"	24	20	1	180
24/16	7/16"	24	24	1 ²	
32/16	15/32", 1/2"	32	28	1 ²	
40/20	5/8", 19/32"	40	32	1	
48/24	3/4"	48	36	2	

1. Span rating and Maximum Roof Sheathing Spans are for reference only, refer to IBC Table 2304.7 (3) for additional important information.
2. Maximum roof sheathing span with single PSCA is 24". For spans > 24" use two PSCA's.

SBV/CF-R Shelf Brackets/Concrete Form Angles

Use the SBV for shelving, counter brackets, window ledge supports, at a very competitive price.

The CF-R is used where a moderate size shelf bracket and reinforcing angle is needed. When used for tilt-up perimeter forming, the nail hole placement ensures substantial re-use.

MATERIAL: 16 gauge **FINISH:** Galvanized
INSTALLATION: • Use all specified fasteners. See General Notes.
• SBV—Reversible for nominal 10" or 12" shelves of any thickness.
• CF-R (Retail Pack)—Recommended spacing is 36" for 2x's and 18" for 1x's. Use the 5" leg for 6" lumber and the 6" leg for 8" lumber. Holes are sized for 1/4" fasteners or 10d commons.

CODES: See page 12 for Code Reference Key Chart.

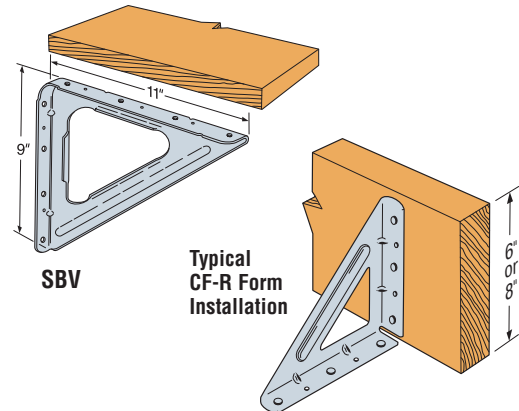

Model No.	Fasteners	DF/SP Allowable Downloads (100)	Code Ref.
	Stud		
CF-R	3-SDS 1/4"x2"	135	170
SBV	4-SDS 1/4"x2"	145	

DS Drywall Stop

Eliminates costly blocking at top plate, end walls, and corners. A typical residence will use several hundred of these inexpensive clips with a substantial savings in blocking and labor.

The installation prongs provide even more labor savings.

MATERIAL: 20 gauge
FINISH: Galvanized
INSTALLATION:
• 16" on center or less, using 8d commons.
• DS should not be used where gypsum board is used for structural loads.

CODES: ICC ESR-2614, Florida FL-10865.4, City of L.A. RR 25962

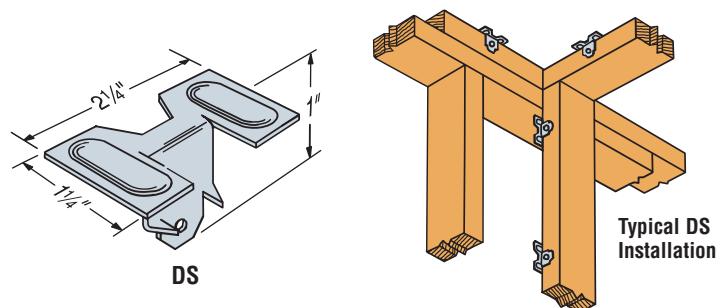

RTC/FWH Rigid Tie™ Connectors

The Rigid Tie™ RTC series secures two wood members to a vertical post forming a 90° corner. The RTC42 and RTC44 are heavy-duty structural connectors. Based on loads of 40 lbs. per sq. ft., a 10'x10' deck can be built using 2x8 joists and 4 RTC42s. See the table for post and joist sizes.

- RTB**—a bracket for intersecting 2x members.
- FWH**—4 way connectors for 2x members with bendable flanges.
- RTA**—connects two 2x wood members at a 90° angle.
- RTF**—connects two members in a “pass-through” application.
- RTR and RTU**—a 2x member crosses another.

MATERIAL: RTC44—14 gauge; RTA2—16 gauge; RTR and RTB—20 gauge; all others—18 gauge
FINISH: Galvanized. Some products available in stainless steel or ZMAX® coating; see Corrosion Information, pages 13-15.

INSTALLATION: • Use all specified fasteners. See General Notes.

- Install vertical members first, then attach horizontal members for easier alignment.
- Seat wood member in bracket with a C-clamp before securing to aid positioning and prevent skewing.
- Always follow manufacturer’s instructions when using power tools and building equipment.

CODES: See page 12 for Code Reference Key Chart.

These products are available with additional corrosion protection. Additional products on this page may also be available with this option, check with Simpson Strong-Tie for details.

These products are approved for installation with the Strong-Drive® SD Connector screw. See page 27 for more information.

Model No.	Post Size	Joist Size	Fasteners (Total)		Allowable Downloads		Code Ref.
			Post	Joist	Floor (100)	Roof (125)	
FWH2	2x	2x	8-SD8x1.25	8-SD8x1.25	N/A	N/A	180
RTA12	1x	1x	8-SD8x1.25	8-SD8x1.25	N/A	N/A	
RTA2Z	2x	2x	4-SD#9x1½	4-SD#9x1½	150	150	
RTA4	4x	4x	7-SD8x1.25	5-SD8x1.25	N/A	N/A	
RTB22	2x	2x	4-SD8x1.25	4-SD8x1.25	N/A	N/A	
RTC22Z	2x	2x	5-SD#9x1½	6-SD#9x1½	775	775	118, F17, 160
RTC24	Discontinued – See RTC2Z						
RTC2Z	2x4	2x	6-SD8x1.25	6-SD8x1.25	300	375	
			6-10dx1½	6-10dx1½	710	875	
			6-SD#9x1½	6-SD#9x1½	1025	1260	
RTC42	4x4	2x	14-SD8x1.25	8-SD8x1.25	650	810	
			14-16d	8-10dx1½	1975	2430	
			14-SD#10x1½	8-SD#10x1½	2420	3030	
RTC44	4x4	4x	14-16d Sinks	15-16d Sinks	1770	2140	
			14-16d	15-16d	2085	2530	
			14-SD#10x1½	15-SD#10x1½	2420	3030	
RTF2Z	2x4	2x	4-SD#9x1½	8-SD#9x1½	685	855	180
RTT2Z	2x	2x	3-SD#9x1½	7-SD#9x1½	500	500	
RTR	2x	2x	2-SD8x1.25	4-SD8x1.25	N/A	N/A	
RTU2	2x	2x	2-SD8x1.25	4-SD8x1.25	N/A	N/A	

- Allowable loads must be equally distributed on both joists.
- Loads are for Doug Fir Larch.
- NAILS:** 16d = 0.162" dia. x 3½" long, 16d Sinker = 0.148" dia. x 3¼" long, 10dx1½ = 0.148" dia. x 1½" long. See pages 22-23 for other nail sizes and information.
- SCREWS:** SD#9x1½ = 0.131" dia. x 1½" long, SD#10x1½ = 0.161" dia. x 1½" (see page 27), SD#8x1¼ = 0.156" dia. x 1¼" long.

To learn more about the new WBSK Workbench and Shelving Unit Hardware Kit that includes RTC2Zs, fasteners and plans to build a workbench or shelving unit, visit www.diydoneright.com.

WARNING: Industry studies show that hardened fasteners can experience performance problems in wet and corrosive environments. Accordingly, use the #8x1¼ SD Wafer-Head screw in dry, interior, and non-corrosive environments only.

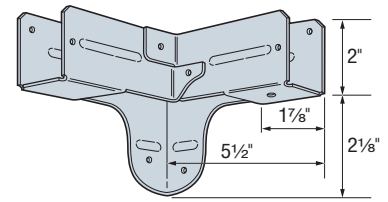

RTC2Z

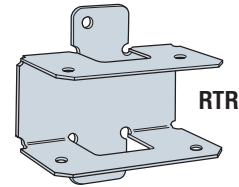

RTR

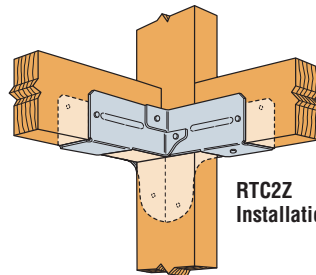

RTC2Z Installation

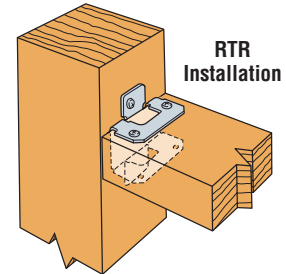

RTR Installation

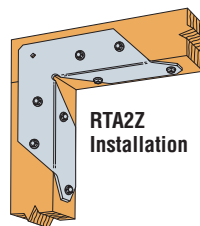

RTA2Z Installation

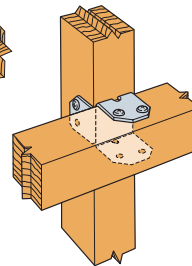

FWH2 Installation

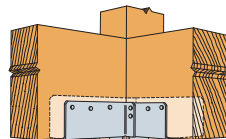

RTB22 Installation

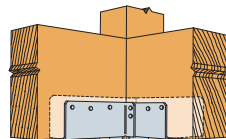

RTC44 Installation (RTC2Z similar)

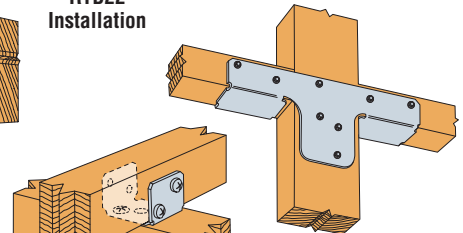

RTF2Z Installation

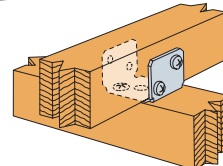

RTU2 Installation

J/JP Floor Beam Levelers

Jack piers and standard floor beam levelers offer unique leveling simplicity during and after construction.

MATERIAL: 12 gauge plates, ¾" threaded rod, 1½" O.D. steel pipe
FINISH: None.

INSTALLATION: • Use all specified fasteners. See General Notes.

- Holes are provided for installation with 4-10dx1½" nails.
- Do not use J/JPs for dynamic jacking of structures, such as houses.

CODES: See page 12 for Code Reference Key Chart.

Model No.	Dimensions		Allowable Bearing Loads (DF/SP/SPF/HF) (100)	Code Ref.
	H (Min-Max) (in.)	Threaded Rod Length (in.)		
JP44	2-4	4¾	4440'	170
J57	5-7	4	4380	

- Post design by Designer. See pages 245-246 for post allowable loads.
- Loads may not be increased for short-term loading.
- NAILS:** 10dx1½ = 0.148" dia. x 1½" long. See pages 22-23 for other nail sizes and information.

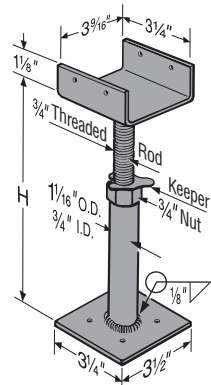

J57 Floor Beam Leveler

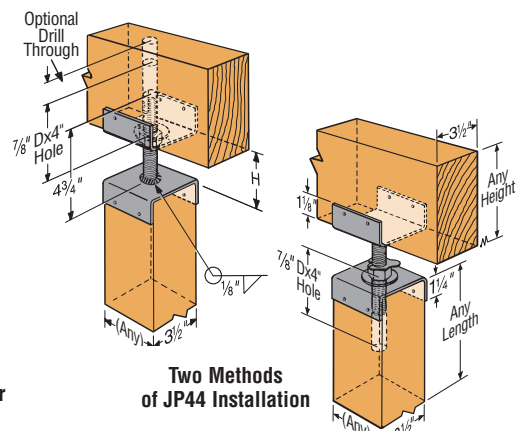

Two Methods of JP44 Installation

NS/PSPNZ Nail Stoppers

Nail stoppers help prevent nails from piercing pipes and electrical lines. Installed over utilities that pass through framing members.

PSPN516Z and PSPN58Z protecting shield plate nail stoppers meet IRC, IBC and the International Plumbing Code. PSPN516Z meets structural and protection requirements with one strap.

MATERIAL: 16 gauge

FINISH: Galvanized, PSPN-ZMAX® coating, see Corrosion Information, pages 13-15.

INSTALLATION: • PSPN516Z – 16d commons (see footnote 2 below).

- Other models – 8d commons or prongs.

For more information request flier F-REPRPROTECT.

CODES: See page 12 for Code Reference Key Chart.

PSPN516Z (16 gauge ZMAX) at top plates

- International Residential Code® – 2009/2012 P2603.2.1 & R602.6.1
- International Building Code® – 2009/2012 2308.9.8
- International Plumbing Code – 2009-305.8 / 2012-305.6

PSPN516Z (16 gauge ZMAX) at bottom plate.

- International Building Code® – 2009/2012 2308.9.8
- International Plumbing Code – 2009-305.8 / 2012-305.6

PSPN58Z (16 gauge ZMAX) at top plates and bottom plate.

- International Plumbing Code – 2009-305.8 / 2012-305.6
- International Residential Code® – 2009/2012 P2603.2.1

NS1 – Nail stops to protect supply lines from drywall nails or screws.

- International Residential Code® – 2009/2012 Table E3702.1
- National Electric Code – 2008/2011 300.4

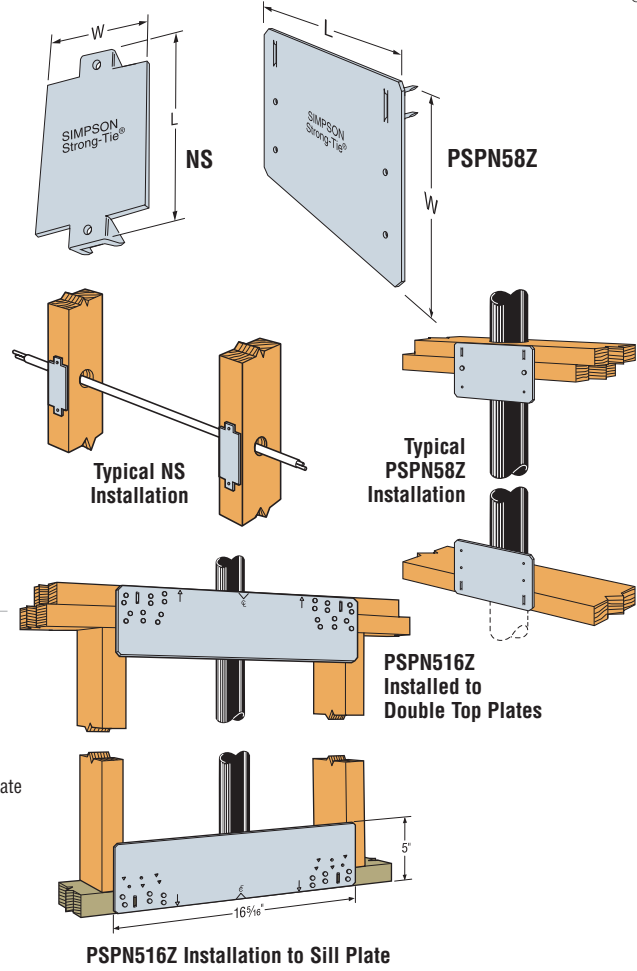

These products are available with additional corrosion protection. Additional products on this page may also be available with this option, check with Simpson Strong-Tie for details.

These products are approved for installation with the Strong-Drive® SD Connector screw. See page 27 for more information.

Model No.	W	L	Code Ref.
NS1	1½	3	190
NS2	1½	6	
PSPN58Z	5	8	
PSPN516Z	5	16 5/16	

1. PSPN516Z—12-16d nails into sill plate achieves 1365 lbs. for DF/SP, and 1180 lbs. for SPF/HF. 24-16d nails into top plates achieves 1820 lbs. for DF/SP, and 1575 lbs. for SPF/HF.

2. To meet the prescriptive IRC requirement 16d box nails (0.135" dia. x 3 1/2") may be used.

3. **NAILS:** 16d = 0.162" dia. x 3 1/2" long, 8d = 0.131" dia. x 2 1/2" long. See pages 22-23 for other nail sizes and information.

CTS218 Compression and Tension Straps

The CTS218 is designed to repair wood members such as top plates, studs and trusses and is our first strap that handles both tension and compression loads. The unique rolled edges of the strap allow it to span gaps as wide as 4 1/2" and its 1 1/2" width enables installation on the narrow face of 2x lumber.

- Tested specifically for top/bottom plate repair with various multi-strap configurations
- Meets the requirements of the IBC and IRC for repairing top plates that have been cut or notched to accommodate plumbing or HVAC ductwork

MATERIAL: 14 gauge **FINISH:** Galvanized

INSTALLATION: • Use all specified fasteners. See General Notes.

- **One-sided installations** – install one or two CTS straps on the same side of the member.
- **Two-sided installation** – install CTS straps on opposite sides of member. For three-part installations, install two parts on one side, one part on opposite side.

CODES: See page 12 for Code Reference Key Chart.

- International Building Code® – 2009/2012 2308.9.8

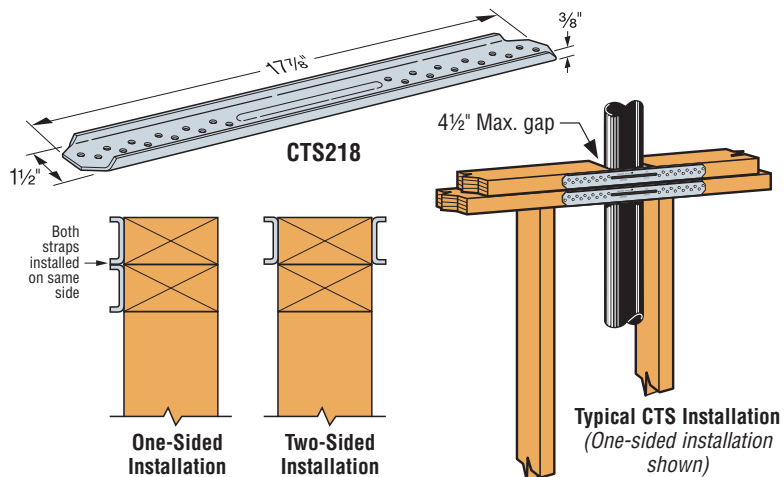

Model No.	Strap Qty.	Installation	Fasteners (Per Strap)	Allowable Loads DF/SP		Allowable Loads SPF/HF		Code Ref.
				Compression (160)	Tension (160)	Compression (160)	Tension (160)	
CTS218	1	One Sided	24 -10dx1½	1020	2270	880	1970	F24, I4, L3
	2	One Sided		2045	4540	1760	3940	
	2	Two Sided		2370	4540	2040	3940	
	3	Two Sided		3725	6810	3205	5910	
	4	Two Sided	4740	9080	4080	7880		
	1	One Sided	24 - SD #9x1½	1175	2480	1010	2150	
	2	One Sided		2350	4960	2020	4300	
	2	Two Sided		2735	4960	2350	4300	
3	Two Sided	4130		7440	3550	6450		
	4	Two Sided	5470	9920	4700	8600		

These products are approved for installation with the Strong-Drive® SD Connector screw. See page 27 for more information.

1. Allowable loads have been increased for wind or seismic with no further increase allowed. Reduce where other loads govern.
2. Fastener quantities are for a single strap.
3. Maximum gap between wood members is 4 1/2".
4. **FASTENERS:** 10dx1 1/2 = 0.148" dia. x 1 1/2", SD #9x1 1/2 = 0.131" dia. x 1 1/2" long. See pages 22-23 for other nail sizes and information.

RPS Strap Ties

The RPS meets IBC, IRC and City of Los Angeles code requirements for HVAC and pipes in walls.

FINISH: Galvanized, some products available in ZMAX® coating. See Corrosion Information, pages 13-15.

INSTALLATION: Use all specified fasteners. See General Notes.

CODES: See page 12 for Code Reference Key Chart.

Use RPS22 or RPS28 (16 gauge) to reinforce top plate. Use RPS18Z, RPS22Z or RPS28Z (16 gauge ZMAX) to reinforce sill plate.

- International Residential Code® – 2009/2012 R602.6.1
- International Building Code® – 2009/2012 2308.9.8

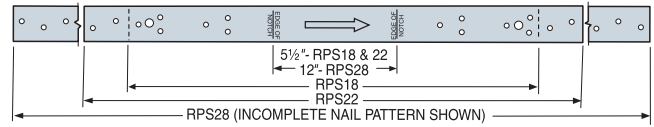

RPS

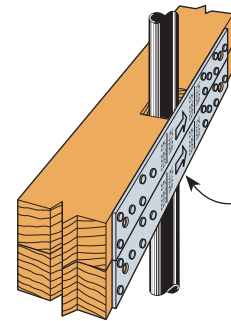

For installations on both sides of the plate, arrows should always point to the right.

Typical RPS Installation
(Only one strap may be necessary to meet IRC requirements)

These products are available with additional corrosion protection. Additional products on this page may also be available with this option, check with Simpson Strong-Tie for details.

Model No.	Ga	Dimensions		Notch Width	Fasteners (Total)	Allowable Tension Loads (DF/SP)	Allowable Tension Loads (SPF/HF)	Code Ref.
		W	L					
RPS18	16	1 1/2"	18 3/16"	≤ 5 1/2"	12-16d	1380	1190	116, L9, F15
RPS22	16	1 1/2"	22 3/16"	≤ 5 1/2"	12-16d	1380	1190	
RPS22	16	1 1/2"	22 3/16"	≤ 5 1/2"	16-16d	1805	1585	
RPS28	16	1 1/2"	28 3/16"	≤ 12"	12-16d	1380	1190	
RPS28	16	1 1/2"	28 3/16"	≤ 12"	16-16d	1805	1585	

1. Loads include a 60% load duration increase on the fasteners for wind or earthquake loading.
2. To meet the prescriptive IRC requirement 10dx1 1/2" (0.148" dia. x 1 1/2" long) may be used.
3. **NAILS:** 16d = 0.162" dia. x 3 1/2" long. See pages 22-23 for other nail sizes and information.

HSS/SS Stud Shoes

Stud shoes reinforce studs notched in construction. They are NOT a total replacement of removed material. Installs over pipe up to 2 3/8" outside diameter. HSS2-3 is designed for triple 2x studs.

HSS stud shoes provide tension load capacity as well as increased compression loads. Flared flange provides greater strength.

MATERIAL: 16 gauge **FINISH:** Galvanized

INSTALLATION: Use all specified fasteners. See General Notes.

- HSS—Bend flanges at 90° angle during installation, then bend back and screw into position (*screws supplied*).
- Bend flanges one cycle only.

CODES: See page 12 for Code Reference Key Chart.

HSS2-SDS1.5 (16 gauge) Heavy stud shoes to reinforce and protect single 2x studs where pipe is located. Uses 12 Simpson Strong-Tie® 1/4" x 1 1/2" Strong-Drive® SDS Heavy-Duty Connector screws (*included*).

- International Residential Code® – 2009/2012 R602.6 & P2603.2.1
- International Building Code® – 2009/2012 2308.9.10 & 2308.9.11
- International Plumbing Code – 2009-305.8 / 2012-305.6

HSS2-3-SDS3 (16 gauge) Heavy stud shoe for triple 2x stud. Uses 12 Simpson Strong-Tie® 1/4" x 3" Strong-Drive SDS Heavy-Duty Connector screws (*included*).

- International Residential Code® – 2009/2012 R602.6 and P2603.2.1
- International Building Code® – 2009/2012 2308.9.10 & 2308.9.11
- International Plumbing Code – 2009-305.8 / 2012-305.6

SS1.5 (16 gauge) stud shoes reinforce and protect plumbing in 2x.

- International Residential Code® – 2009/2012 R602.6 and P2603.2.1
- International Building Code® – 2009/2012 2308.9.10 & 2308.9.11
- International Plumbing Code – 2009-305.8 / 2012-305.6

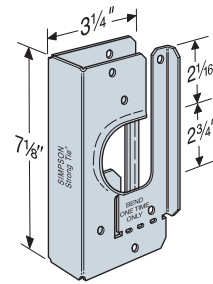

HSS

US Patent 6,176,057

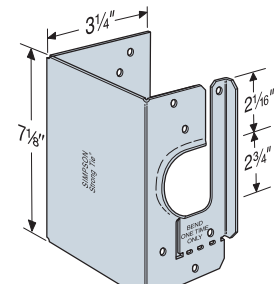

HSS2-3

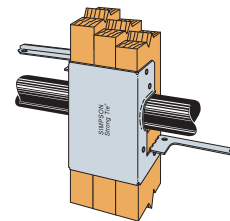

STEP 1
Install HSS (*HSS2-3 shown*) over stud with flanges bent at a 90° angle.

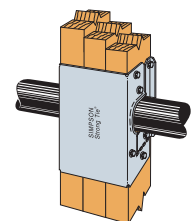

STEP 2
Bend HSS (*HSS2-3 shown*) flanges one time only. Screw into position.

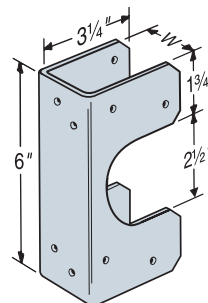

SS

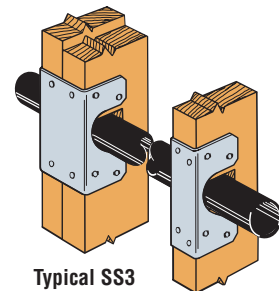

Typical SS3 Installation

Typical SS1.5 Installation

Model No.	Stud Size	W (in.)	Fasteners	Allowable Loads ¹			Code Ref.
				DF/SP			
				Compression		Tension	
				Floor (100)	Roof (125)		
SS1.5	2x	1 1/16"	12-10dx1 1/2"	500	500	—	116, F15
SS2.5	3x	2 3/16"	12-10dx1 1/2"	500	500	—	
SS3	2-2x	3 1/16"	12-10d	665	785	—	
SS4.5	3-2x	4 3/16"	14-10d	665	785	—	
HSS2-SDS1.5	2x	1 1/16"	12-SDS 1/4" x 1 1/2"	1200	1200	1000	
HSS2-2-SDS3	2-2x	3	12-SDS 1/4" x 3"	1200	1200	1000	
HSS2-3-SDS3	3-2x	4 3/16"	12-SDS 1/4" x 3"	1000	1000	970	
HSS4-SDS3	4x	3 3/16"	12-SDS 1/4" x 3"	1200	1200	1000	

1. Roof loads are 125% of floor loads unless limited by other criteria. Floor loads may be adjusted for other load durations according to the code, provided they do not exceed roof loads.
2. **NAILS:** 10d = 0.148" dia. x 3" long, 10dx1 1/2" = 0.148" dia. x 1 1/2" long. See pages 22-23 for other nail sizes and information.

NCA/TB/LTB Bridging

NCA—Nailless installation eliminates callbacks for nail squeaks. Designed for secure grip before the drive-home blow, and deeper prong penetration. Precision-formed into a rigid “V” section.

TB—Tension-type bridging with maximum nailing flexibility. Use just two of the seven nail holes at each end.

LTB—Staggered nail pattern accommodates 2x8 and 2x10 joists. Use just two of the six nail holes at each end. LTB40 has rigid prongs that install easily into the joist, and embossments that allow crisp bends.

MATERIAL: LTB—22 gauge; NCA and TB—20 gauge
(except NCA2x12-16—18 gauge).

FINISH: Galvanized

INSTALLATION: • Support floor joists with a depth-to-thickness ratio of six or more with bridging at intervals not exceeding 8'. If span is greater than 8', install on 2x8 or larger joists. If span is greater than 16', use more than one pair.

- Tension bridging works only in tension, so must be used in cross pairs.
- Install bridging tightly; loose installation may allow floor movement.
- NCA may be installed before or after sheathing, from the top or bottom. Simply locate the bend line approximately 1" from the joist edge.
- NCA has nail holes in one end for use if a prong is bent during installation. Fully seat nails if they are used; otherwise, they may lead to squeaks.
- TB requires two 10dx1½ fasteners per end.
- LTB requires two 6d commons per end.

CODES: See page 12 for Code Reference Key Chart.

Code Reference: IRC 2009/2012, R502.7.1, R802.8.1

Space bridging to avoid contact noises.

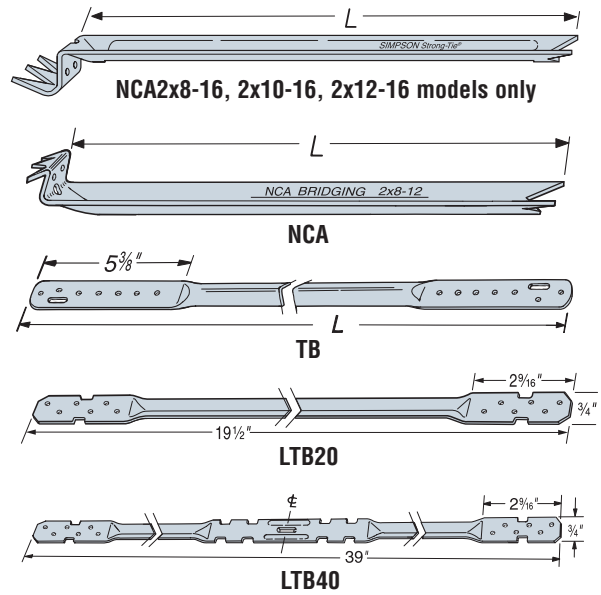

TENSION BRIDGING FOR I-JOISTS

Joist Height (in.)	Joist Spacing (in.)								
	12	16	19.2	24	30	32	36	42	48
9½	TB20	TB27	TB27	TB30	TB36	TB36	TB42	TB48	TB54
10	TB20	TB27	TB27	TB30	TB36	TB36	TB42	TB48	TB54
11½	TB20	TB27	TB27	TB30	TB36	TB36	TB42	TB48	TB54
12	TB20	TB27	TB27	TB30	TB36	TB36	TB42	TB48	TB54
14	TB27	TB27	TB27	TB36	TB36	TB42	TB42	TB48	TB54
16	TB27	TB27	TB30	TB36	TB42	TB42	TB42	TB48	TB54
18	TB27	TB30	TB30	TB36	TB42	TB42	TB48	TB54	TB56
20	TB30	TB30	TB36	TB36	TB42	TB42	TB48	TB54	TB56
22	TB30	TB36	TB36	TB36	TB42	TB42	TB48	TB54	TB56
24	TB36	TB36	TB36	TB42	TB42	TB48	TB48	TB54	TB56
26	TB36	TB36	TB36	TB42	TB48	TB48	TB48	TB54	TB60
28	TB36	TB36	TB42	TB42	TB48	TB48	TB54	TB54	TB60
30	TB36	TB42	TB42	TB42	TB48	TB48	TB54	TB56	TB60
32	TB42	TB42	TB42	TB42	TB48	TB48	TB54	TB56	TB60

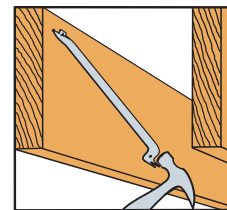
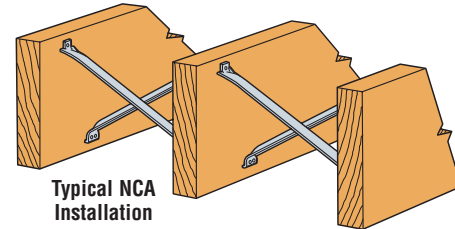
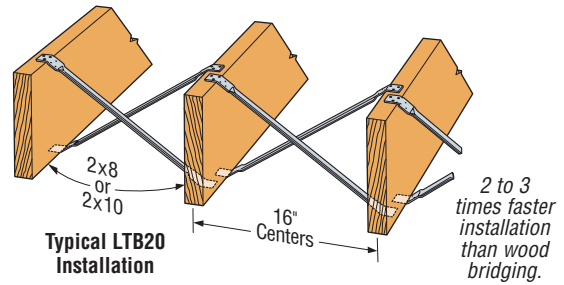

Install from below as shown, or from above. Drive upper end into joist approximately 1" from the top.

For all bridging avoid direct contact between steel members (this may cause squeaks).

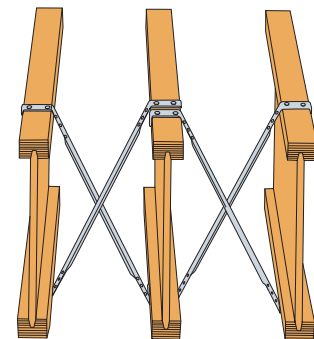

Typical TB Installation

TENSION BRIDGING FOR SOLID SAWN LUMBER

Joist Size	Spacing (in.)	NCA		TB		LTB	Code Ref.
		Model No.	L	Model No.	L	Model No.	
2x10	12	NCA2x10-12	12½	TB20	20	—	I16, F15, L9
2x12	12	NCA2x12-12	13 5/8	TB20	20	—	
2x14	12	NCA2x8-16	15¼	TB27	27	—	
2x16	12	NCA2x10-16	15 13/16	TB27	27	—	
2x8	16	NCA2x8-16	15¼	TB27	27	LTB20 or 40	
2x10	16	NCA2x10-16	15 13/16	TB27	27	LTB20 or 40	
2x12	16	NCA2x12-16	16 7/8	TB27	27	—	
2x14	16	—	—	TB27	27	—	
2x16	16	—	—	TB27	27	—	
2x10	24	—	—	TB30	30	—	
2x12	24	—	—	TB36	36	—	I16, F15, L9
2x14	24	—	—	TB36	36	—	
2x16	24	—	—	TB36	36	—	

WB/WBC/TWB/RCWB Wall Bracing

Simpson Strong-Tie® wall bracing products offer effective options to resist racking during construction. Additionally the RCWB and WB/WBC can be used to fulfill the same code bracing requirements as a 1x4 let-in brace, but are cost effective and faster to install. Not designed to replace structural panel shearwall load-carrying component.

The WBC (*coiled WB*) multiple product dispenser pack weighs less than 40 pounds, making storage and transportation easy. WB106C—15 pieces per roll, WB126C—12 pieces per roll, WB143C—10 pieces per roll.

The RCWB features a rolled edge (*the TWB has two rolled edges*) for extra strength and safety.

MATERIAL: WB and WBC—16 gauge; TWB—22 gauge; RCWB—20 gauge

FINISH: Galvanized

INSTALLATION: • Use all specified fasteners. See General Notes.

WB and WBC: • Install in “X” pairs or in opposing “V” fashion.

• Use with 16” or 24” o.c. 2x4 (min.) studs.

RCWB and TWB: • Use with 16” o.c. studs.

• Use minimum of 2x4 studs with TWB.

• Use minimum of 2x6 studs with RCWB (*2x4 min. for interior, non-bearing wall*).

• Establish a run-line using the bracing as a straight edge. Single cut a saw kerf 5/8” deep (TWB) or 1 1/8” deep (RCWB) along the run line. If the wall is pre-framed on the floor, place the part into the saw kerf, and put one nail into the top plate. Tilt the wall up and plumb before nailing off top plate, bottom plate and studs according to the nailing schedule.

CODES: See page 12 for Code Reference Key Chart.

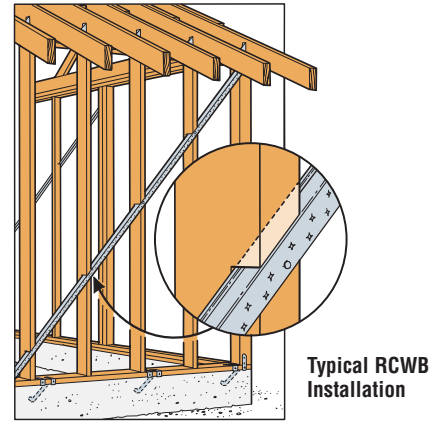
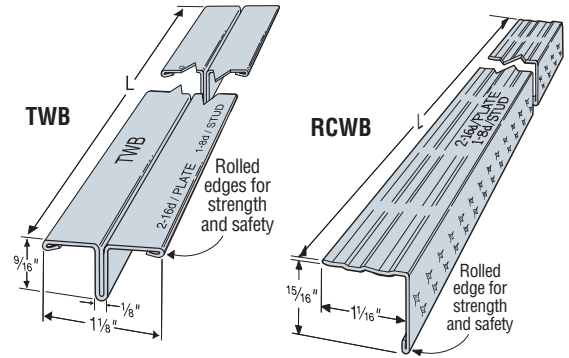
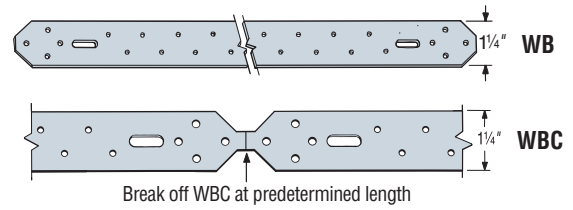

Model No.	L	Angle and Wall Height	Fasteners		Code Ref.
			Plates	Studs	
WB106	9'-5 5/8"	8' @ 60	2-16d	1-8d	I16, L9, F15
WB106C	9'-6"	8' @ 60	2-16d	1-8d	
TWB10	9'-9"	8' @ 55	2-16d	1-8d	I16, L9, F15
RCWB12	11'-4"	8' @ 45	2-16d	1-8d	I16, F15
WB126	11'-4 3/8"	8' @ 45	2-16d	1-8d	I16, L9, F15
WB126C	11'-4 3/4"	8' @ 45	2-16d	1-8d	
TWB12	11'-4"	8' @ 45	2-16d	1-8d	I16, L9, F15
RCWB12	11'-4"	9' @ 53	2-16d	1-8d	I16, F15
WB126	11'-4 3/8"	9' @ 53	2-16d	1-8d	I16, L9, F15
WB126C	11'-4 3/4"	9' @ 53	2-16d	1-8d	
TWB12	11'-4"	9' @ 53	2-16d	1-8d	I16, L9, F15
WB143C	14'-3"	10' @ 45	2-16d	1-8d	
RCWB14	14'-2"	10' @ 45	2-16d	1-8d	
TWB14	14'-2"	10' @ 45	2-16d	1-8d	

1. **NAILS:** 16d = 0.162" dia. x 3 1/2" long, 8d = 0.131" dia. x 2 1/2" long. See pages 22-23 for other nail sizes and information.

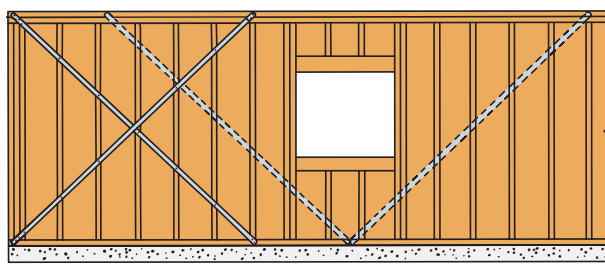

WB or WBC Wall Bracing “X” and “V” Applications

IS Insulation Supports

The insulation supports are cut from carbon steel, spring wire for optimum flexibility and strength. Mitered tips dig into the wood, securing itself and insulation when installed between joists.

MATERIAL: 14 gauge **FINISH:** None

INSTALLATION: • Install between joists. IS16 for 16” o.c. spacing; IS24 for 24” o.c. spacing. Follow insulation manufacturer’s installation instructions.

• Wear safety glasses, gloves and other appropriate safety equipment.

CODES: See page 12 for Code Reference Key Chart.

Model	Diameter	Length (in.)	Joist Spacing	Code Ref.
IS16-R100	0.08	15 1/2	16" o.c.	180
IS24-R100	0.08	23 1/2	24" o.c.	



IS16 (IS24 similar)



Typical IS Installation

ICFVL Ledger Connector System

The ICFVL Ledger Connector System is engineered to solve the challenges of mounting wood or steel ledgers to insulated concrete form (ICF) walls. The ICFVL is designed to provide both vertical and lateral, in-plane performance. The system offers many benefits over traditional anchor bolting, including better on center spacing in most cases, faster installation and no protrusions.

The embedded legs of the ICFVL are embossed for additional stiffness and the hole enables concrete to flow through and around the connector. The exposed flange on the face of the ICF provides a structural surface for mounting either a wood or steel ledger.

MATERIAL: ICFVL—14 gauge; ICFVL-CW and ICFVL-W—16 gauge

FINISH: Galvanized

INSTALLATION: ICFVL in ICF

- For use with a minimum 4" thick core
- Snap a chalk line for the bottom of the ledger
- Mark required on center spacing
- Use ICFVL to mark kerfs locations
- Cut kerfs as marked
- Insert ICFVL flush to the face of the ICF
- Pour concrete

Wood Ledger Attachment – ICFVL-W or -CW

- Slip appropriate ledger connector underneath the ledger
- Install the eight ICF-D3.62 screws partially into the ledger
- Position **bottom** of the ledger level to the chalk line and drive the screws through the wood and into the ICFVL

Steel Ledger Attachment

- Position **bottom** of the ledger level to the chalk line and against the ICFVL
- Attach with four 1/4"-14x3/4", #3 drill point screws (*not provided*)
- All screws should be located at least 1/2" from the edge of the ICFVL
- Space screws evenly

CODES: See page 12 for Code Reference Key Chart.

WARNING:
Industry studies show that hardened fasteners can experience performance problems in wet environments. Accordingly, use this product in dry environments only.

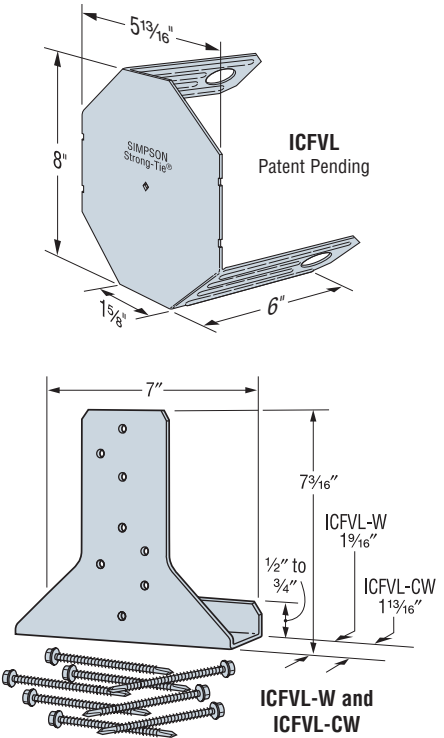

Ledger Type	Fasteners	Allowable Loads (lbs)	
		Download (100/115/125)	Lateral F ₁ (160)
Wood	8-ICF-D3.62	1940	1905
Steel	4-1/4x3/4 ³	1660	1525

1. Fasteners for wood ledger (ICF-D3.62) are provided with the part and fasteners for steel ledger are not provided.
2. Loads apply to ICF foam thicknesses of 3 3/4" or less.
3. Alternately, #14 x 3/4" fastener may be used.
4. Tabulated loads may not be increased.
5. Concrete f'c = 2500 psi minimum.
6. When combining download and lateral loads,

Designer shall evaluate as follows:

Design Download/Allowable Download + Design Lateral Load/Allowable Lateral Load ≤ 1.

7. The ICFVL must be installed no closer than 4" below the top of the wall to achieve the allowable loads shown. For installations where the ICFVL is installed less than 4" from the top of the wall (*including flush applications*) multiply the allowable loads by 0.94.

These tables address vertical load applications only.

Ledger Type	Connector Type	ICFVL SPACING TO REPLACE ANCHOR BOLTS (in) ^{1,2,3}																Code Ref.
		1/2" Dia. Anchors at				5/8" Dia. Anchors at				(2)-5/8" Dia. Anchors at				3/4" Dia. Anchors at				
		12" O.C.	24" O.C.	36" O.C.	48" O.C.	12" O.C.	24" O.C.	36" O.C.	48" O.C.	12" O.C.	24" O.C.	36" O.C.	48" O.C.	12" O.C.	24" O.C.	36" O.C.	48" O.C.	
WOOD LEDGERS																		
DF/SP/SPF	ICFVL w/ ICFVL-W	48	48	48	48	48	48	48	48	24	48	48	48	42	48	48	48	170
LVL	ICFVL w/ ICFVL-CW	48	48	48	48	48	48	48	48	24	48	48	48	42	48	48	48	
STEEL LEDGERS																		
68 mils (0.068")	ICFVL	11	22	33	44	9	18	27	36	—	—	—	—	—	—	—	—	170
54 mils (0.054")	ICFVL	15	30	45	48	12	24	36	48	—	—	—	—	—	—	—	—	

1. The Designer may specify different spacing based on the load requirements.
2. Spacings are based on perpendicular to grain capacity of bolt in wood ledger compared to tested value of ICFVL. Additional connectors required for out-of-plane loads.
3. See flier F-ICFVL for additional connection details.
4. For steel ledgers, the 68 mil ledger spacing is closer than the 54 mil ledger because the calculated load of a bolt is higher in a thicker piece of steel.
5. Steel ledger values are based on steel. F_u = 60 ksi.
6. Maximum ICF foam thickness is 2 3/4".

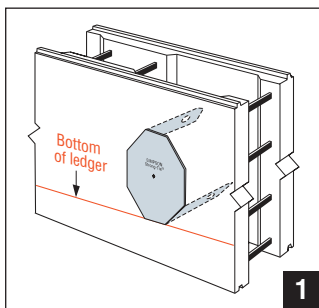

ICFVL

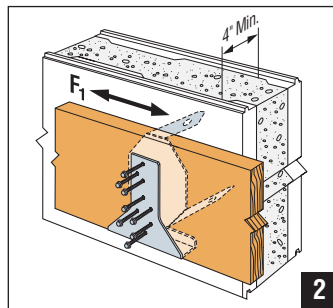

Typical Wood Ledger Installation with ICFVL and ICFVL-W

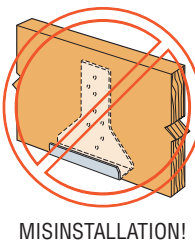

MISINSTALLATION!

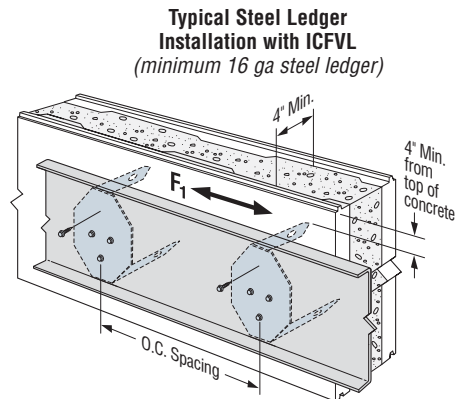

Requires 4 screws at each location. Table provides on center spacing.

FC Framing Clips

For fast, accurate framing. Three-dimensional nailing pattern results in high-strength joint values. Ideal for fence construction.
MATERIAL: 16 gauge **FINISH:** Galvanized
INSTALLATION: Use all specified fasteners. See General Notes.
CODES: See page 12 for Code Reference Key Chart.

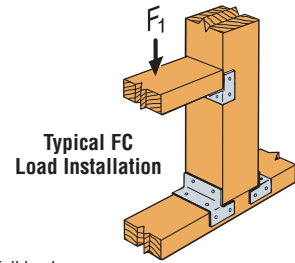
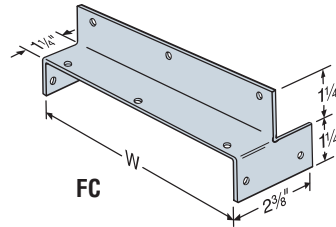

Model No.	W	Fasteners	Allowable F ₁ Loads (100)	Code Ref.
FC4	3 7/16	8-16d	865	IP1, L18, F13
FC6	5 1/2	10-16d	1010	

1. Loads may not be increased for short-term loading.
2. A 2 1/2" minimum lumber thickness is required to achieve the full load.
3. **NAILS:** 16d = 0.162" dia. x 3 1/2" long. See pages 22-23 for other nail sizes and information.

BT Brick Ties

Brick Ties provide a connection between the wood structure and brick façade.
MATERIAL: 22 gauge
FINISH: Galvanized, available in Type 304 stainless steel (order as BTBSS).
INSTALLATION:
 • Holes sized for 10d commons.
 See code for spacing requirements.
CODES: IRC 2009/2012, R703.7.4
TO ORDER: BT-R100 = retail pack of 100
 BTB = bulk carton of 500

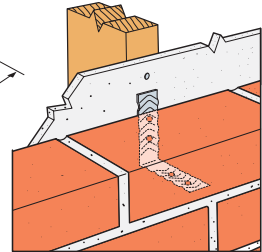
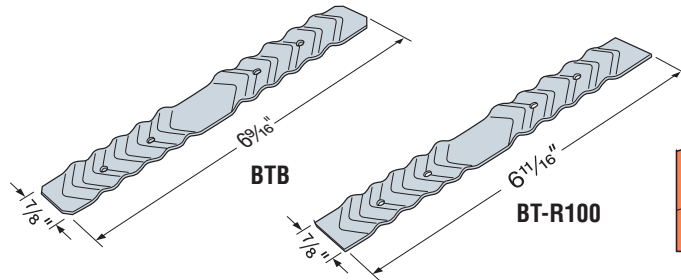

Typical BT Installation

MP Mending Plates

Versatile and easy-to-use mending plates for wood-to-wood connections. No nails or notching of wood required. For non-structural applications only; not for truss applications.
MATERIAL: 20 gauge **FINISH:** Galvanized
INSTALLATION:
 • Place plate over two pieces of aligned wood with arrows aligned at joint.
 • Hammer the plate to embed the prongs.
CODES: See page 12 for Code Reference Key Chart.

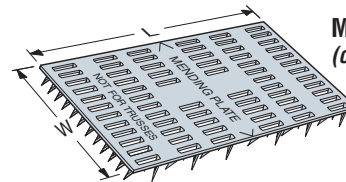

MP36
(other sizes similar)

Model No.	Dimensions		Code Ref.
	W	L	
MP14	1	4	180
MP24	2	4	
MP36	3	6	

1. Connectors are not load rated.

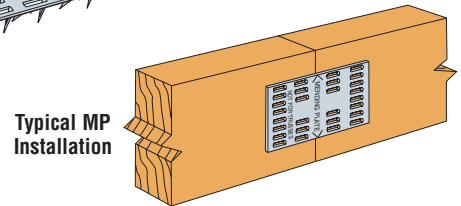

Typical MP Installation

TP/TPA Tie Plates

Tps are nail-on tie plates. TPAs are flanged for added support.
MATERIAL: 20 gauge **FINISH:** Galvanized
INSTALLATION: • Holes are sized for 8d common or 8d x 1 1/2" nails.
CODES: See page 12 for Code Reference Key Chart.

These products are approved for installation with the Strong-Drive® SD Connector screw. See page 27 for more information.

Model No.	Dimensions		Number of Nail Holes	Code Ref.
	W	L		
TP15	1 13/16	5	13	180
TPA37	3 1/2	7	32	
TPA39	3 1/2	9	41	
TP35	3 1/8	5	23	
TP37	3 1/8	7	32	
TP39	3 1/8	9	41	
TP311	3 1/8	11	50	
TP45	4 1/8	5	30	
TP47	4 1/8	7	42	
TP49	4 1/8	9	54	
TP411	4 1/8	11	66	
TP57	5 3/4	7	60	
TPA57	5	7	49	

1. Connectors are not load rated.

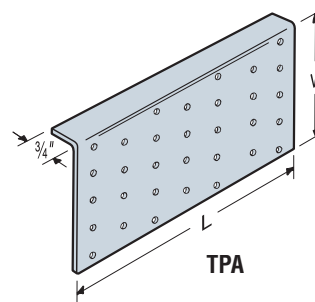

TPA

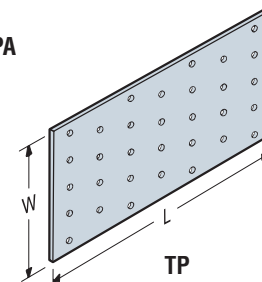

TP

ARCHITECTURAL PRODUCTS GROUP

The **Architectural Products Group** consists of aesthetically pleasing, pre-finished connectors and innovative concealed joist ties designed for exposed wood applications. These connectors provide structural performance and, at the same time, add a unique appearance feature to a project. Refer to Simpson Strong-Tie® C-APG catalog.

• ARCHITECTURAL FINISHES

Eliminate time consuming prep work and costly field painting. Available finishes include textured flat black powder-coat, gray paint and hot-dip galvanized coating.

• AVAILABILITY

Select products are in stock and readily available. Contact Simpson Strong-Tie for product availability and lead times for non-stocked items.

• PRE-ENGINEERED AND TESTED

Load-rated products are verified to perform to design loads, unlike custom designed and fabricated connectors.

• QUALITY ASSURANCE

No-Equal quality-controlled manufacturing ensures product consistency and high quality.



Products shown in this section come with textured flat black powder-coat unless otherwise noted. Most are also available with a galvanized coating or gray primer. Contact Simpson Strong-Tie for availability.

www.strongtie.com/app

BP – BEARING PLATES

Bearing plates give greater bearing surface than standard cut washers, and help distribute the load at these critical connections.

MATERIAL: See table

FINISH: Textured flat black powder-coat

INSTALLATION: See General Notes.

CODES: See page 12 for Code Reference Key Chart.

Model No.	Thickness (in.)	Dimensions		Bolt Dia. (in.)	Code Ref.
		W	L		
BP½PC	¾	2	2	½	190
BP¾-2PC	¾	2	2	¾	
BP¾PC	¾	2½	2½	¾	
BP¾PC	¾	2¾	2¾	¾	
BP¾PC	¾	3	3	¾	
BP1PC	¾	3½	3½	1	

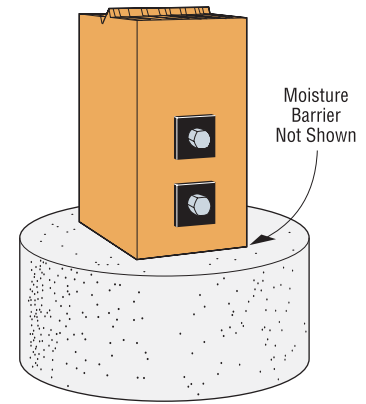
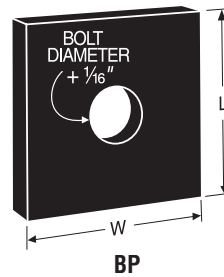

Typical BP Installation

SPECIAL ORDER PARTS

Simpson Strong-Tie can make a variety of flat and bent steel shapes, which include gusset plates for heavy timber trusses, custom ornamental shapes and retaining plates.

MATERIAL: 3 gauge maximum

FINISH: Galvanized, textured powder-coated flat black, Simpson Strong-Tie® gray paint, stainless steel. Contact Simpson Strong-Tie for availability.

TO OBTAIN A QUOTE:

- Supply a CAD drawing in .dxf format complete with plate dimensions, hole diameter and locations, steel thickness, desired finish (*Simpson Strong-Tie Gray Paint, Black Powder-Coat, HDG or raw steel*).
- Total plate shape and size up to maximum dimensions of 48"x48" (approx. 1/16" tolerance).
- Simpson Strong-Tie does not provide product engineering or load values for special order plates.
- Contact Simpson Strong-Tie for pricing information.
- Refer to General Notes, note g on page 16 for additional information.

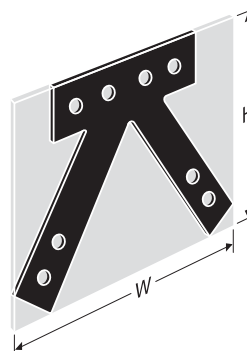

"W" and "H" indicate the envelope size of the steel shape.

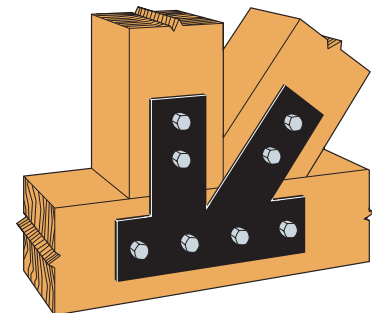

Typical Installation (Plate shown has black powder-coat)

ARCHITECTURAL PRODUCTS GROUP

CONCEALED JOIST TIES

The CJT is a concealed connector. It can be installed three ways: with no routing of header/post or beam; a routed header/post, or a routed beam.

MATERIAL: 12 gauge **FINISH:** Galvanized

INSTALLATION: • Use all specified fasteners.

See General Notes.

- The CJT Pack is supplied with all dowels and screws required. Screws require a hex head driver.
- Router end of beam for screw heads for flush installation.
- The carried member may be sloped **up or down** to 45° with full table loads.
- To provide maximum beam width for use with short dowels, center in beam.
- To order: specify short (e.g. CJT3S) or long dowels (e.g. CJT3L) (see footnote #1 below).

OPTIONS: See technical bulletin **T-C-CJT**.

CODES: See page 12 for Code Reference Key Chart.

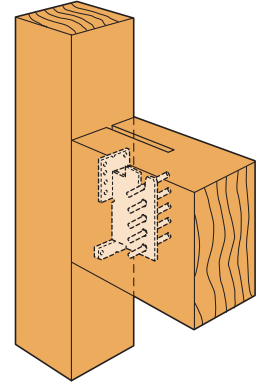
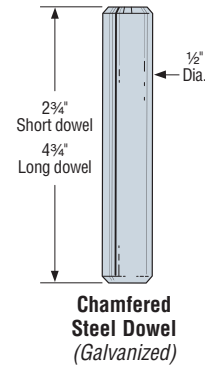
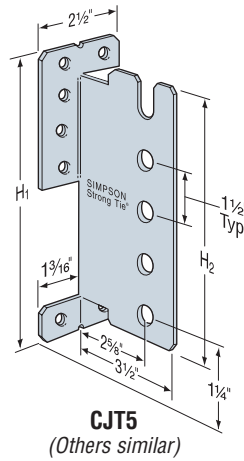

Typical CJT Installation
(Note that dowels should be centered within beam)

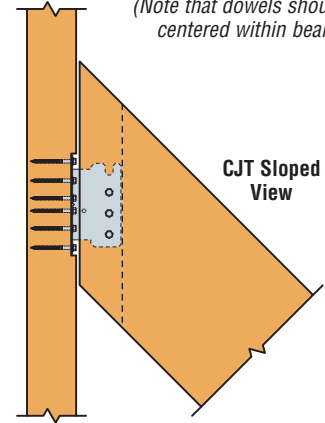

Model No.	Min. Joist Size	Dimensions (in.)		Fasteners (Quantity-Type)		Allowable Loads				Code Ref.
		H ₁	H ₂	Post	Joist Pins (2 3/4" or 4 3/4")	Uplift (160)	Floor (100)	Snow (115)	Roof (125)	
DOUGLAS FIR-LARCH										
CJT3	4x6	5 5/16	4 7/16	6 - 1/4x3" SDS	3 - 1/2"	985	1050	1050	1050	IP5, F17, L13
	4x8	5 5/16	4 7/16	6 - 1/4x3" SDS	3 - 1/2"	1825	1730	1730	1730	
CJT4	4x10	7	5 15/16	8 - 1/4x3" SDS	4 - 1/2"	2780	2420	2785	2970	
CJT5	4x12	8 9/16	7 7/16	10 - 1/4x3" SDS	5 - 1/2"	3490	2950	3390	3685	
CJT6	4x12	10	8 15/16	12 - 1/4x3" SDS	6 - 1/2"	4565	3425	3940	4280	
GLULAM										
CJT3	3 1/8x6	5 5/16	4 7/16	6 - 1/4x3" SDS	3 - 1/2"	1825	1835	1835	1835	IP5, F17, L13
CJT4	3 1/8x7 1/2	7	5 15/16	8 - 1/4x3" SDS	4 - 1/2"	2780	2410	2770	3010	
CJT5	3 1/8x9	8 9/16	7 7/16	10 - 1/4x3" SDS	5 - 1/2"	3490	2925	3360	3655	
CJT6	3 1/8x10 1/2	10	8 15/16	12 - 1/4x3" SDS	6 - 1/2"	4510	3380	3890	4225	
PSL										
CJT3	3 1/2x9 1/2	5 5/16	4 7/16	6 - 1/4x3" SDS	3 - 1/2"	1825	1855	2135	2320	IP5, F17, L13
CJT4	3 1/2x9 1/2	7	5 15/16	8 - 1/4x3" SDS	4 - 1/2"	2780	2440	2805	2810	
CJT5	3 1/2x9 1/2	8 9/16	7 7/16	10 - 1/4x3" SDS	5 - 1/2"	3490	2985	3435	3730	
CJT6	3 1/2x11 3/8	10	8 15/16	12 - 1/4x3" SDS	6 - 1/2"	4650	3485	4010	4360	

- Center dowel in beam. Short dowel (1/2" x 2 3/4") for use with 3/8" glulam beam, 4x sawn lumber, or 3 1/2" wide PSL. Long dowel (1/2" x 4 3/4") for use with 5/8" glulam beam, 6x sawn lumber or greater widths.
- See technical bulletin **T-C-CJT** for additional load information with long dowels.

WARNING:
This connector requires special attention to ensure correct installation. The beam must be installed perpendicular to the support member. The connection's components may be damaged if the beam is rotated from its opposite end during or after installation. Damaged components may not be noticeable and may reduce the connector's load carrying capacity.

ORNAMENTAL – JOIST HANGER

The OHU Ornamental Joist Hangers are heavy duty, load-rated joist hangers that are attached with Simpson Strong-Tie® Strong-Drive® 1/4" x 3" double-barrier coating SDS Heavy-Duty Connector screws (supplied with product).

MATERIAL: 12 gauge

FINISH: Textured powder-coated flat black paint.

OPTIONS: No modifications.

CODES: See page 12 for Code Reference Key Chart.

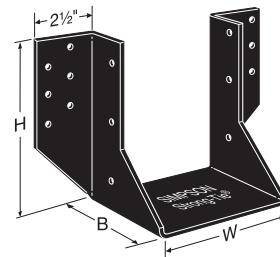

OHU

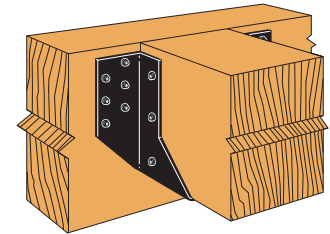

Typical OHU Installation

Model No.	Joist Size	Ga	Dimensions			No. of SDS 1/4"x3" Wood Screws		DF/SP				SPF/HF				Code Ref.
			W	H	B	Face	Joist	Uplift (160)	Floor (100)	Snow (115)	Roof (125)	Uplift (160)	Floor (100)	Snow (115)	Roof (125)	
OHU46-SDS3	4x6	12	3 3/16	5	4	6	4	1930	2520	2900	3150	1390	1800	2070	2250	170
OHU48-SDS3	4x8	12	3 3/16	6 3/4	4	8	6	2765	3360	3865	4200	1990	2400	2760	3000	
OHU410-SDS3	4x10	12	3 3/16	8 3/4	4	12	6	2765	5040	5795	6300	1990	3600	4140	4500	
OHU412-SDS3	4x12	12	3 3/16	10 3/4	4	12	8	3565	5040	5795	6300	2570	3600	4140	4500	
OHU414-SDS3	4x14	12	3 3/16	12 3/4	4	14	10	3565	5880	6760	7350	2570	4200	4830	5250	
OHU66-SDS3	6x6	12	5 1/2	5	4	6	4	1930	2520	2900	3150	1390	1800	2070	2250	
OHU68-SDS3	6x8	12	5 1/2	7	4	12	6	2765	5040	5795	5955	1990	3600	4140	4290	
OHU610-SDS3	6x10	12	5 1/2	9	4	14	6	2765	5880	6760	6885	1990	4200	4830	4960	
OHU612-SDS3	6x12	12	5 1/2	11	4	16	8	3565	6720	7730	7815	2570	4800	5520	5630	
OHU614-SDS3	6x14	12	5 1/2	13	4	18	10	3565	7560	8695	8745	2570	5400	6210	6300	

1. Allowable uplift loads have been increased 60% for wind or earthquake loading with no further increase allowed; reduce where other loads govern.

ARCHITECTURAL PRODUCTS GROUP

CLASSIC COLLECTION

MATERIAL: As noted in tables

FINISH: Textured powder-coated flat black paint

INSTALLATION: • Use all specified fasteners.

See General Notes.

CODES: See page 12 for Code Reference Key Chart.

STRAP TIES

Model No.	Ga	Dimensions			Bolts		Allowable Tension Loads ^{1,2} (160)	Code Ref.
		W	L	Qty	Dia			
HST2PC	7	2½	21¼	6	⅝	5220	I4, L3, F2	
HST5PC	7	5	21¼	12	⅝	10650		
HST3PC	3	3	25½	6	¾	7625		
HST6PC	3	6	25½	12	¾	15360		
PS218PC	7	2	18	4	¾	4990	180	
PS418PC	7	4	18	4	¾	5030		
PS720PC	7	6¾	20	8	½	4685		

- Allowable loads have been increased 60% for wind or earthquake loading with no further increase allowed; reduce where other loads govern.
- Allowable loads are based on parallel-to-grain loading and a minimum member thickness of 3½" with machine bolts in single shear. Straps must be centered about splice joint and bolt edge distances must meet NDS minimum requirements.
- Designer must determine allowable loads when combining bolts parallel and perpendicular to grain.

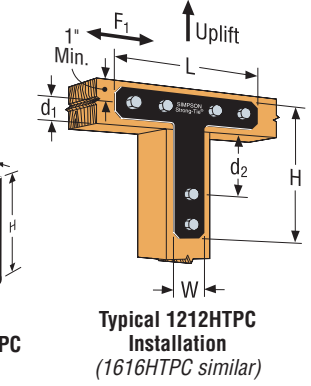
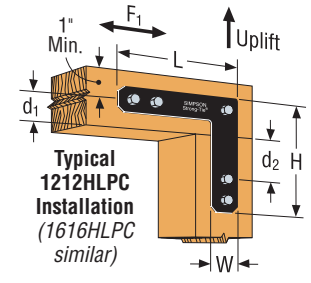
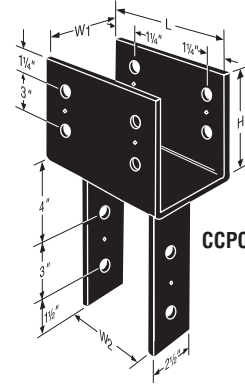
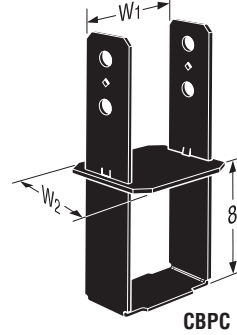
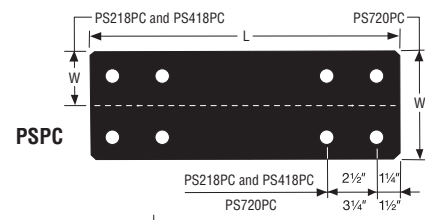
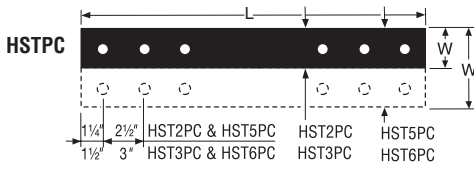

BEAM-TO-COLUMN TIES

Model No.	Ga	Dimensions			Minimum Bolt End & Edge Distances		Bolts		Allowable Loads ^{1,2}		Code Ref.
		W	H	L	d ₁	d ₂	Qty	Dia	Tension/Uplift	F ₁	
									(100/160)	(100/160)	
1212HLPC	7	2½	12	12	2½	4¾	5	⅝	1535	565	170
1616HLPC	7	2½	16	16	2½	4¾	5	⅝	1535	565	
1212HTPC	7	2½	12	12	2½	4¾	6	⅝	2585	815	
1616HTPC	7	2½	16	16	2½	4¾	6	⅝	2585	815	

- 1212HL, 1616HL, 1212HT and 1616HT are to be installed in pairs with machine bolts in double shear. A single part with machine bolts in single shear is not load-rated.
- Allowable loads are based on a minimum member thickness of 3½".
- 1212HT, 1616HT loads assume a continuous beam.

COLUMN BASES

Model No.	Ga	Dimensions			Bolts		Allowable Tension Loads (160)	Code Ref.
		W ₁	W ₂	Qty	Dia			
CB44PC	7	3⅞	3½	2	⅝	4200	IL8	
CB46PC	7	3⅞	5½	2	⅝	4200		
CB48PC	7	3⅞	7½	2	⅝	4200		
CB66PC	7	5½	5½	2	⅝	4200		
CB68PC	7	5½	7½	2	⅝	4200		
CB88PC	3	7½	7½	2	¾	6650		
CB810PC	3	7½	9½	2	¾	6650		

- Allowable loads have been increased 60% for wind or earthquake loading with no further increase allowed; reduce where other loads govern.
- See page 60 for glulam beam sizes. Add PC to the model, i.e. CB5-6PC.
- Minimum side cover for full loads is 3" for CBs.
- Install with bottom of base flush with concrete.
- Post bases do not provide adequate resistance to prevent members from rotating about the base and therefore are not recommended for non top-supported installations (such as fences or unbraced carports).

COLUMN CAPS

Model No.	Ga	Dimensions				Bolts				Allowable Loads		Code Ref.
		W ₁	W ₂	L	H	Beam		Post		Uplift (160)	Down (100)	
						Qty	Dia	Qty	Dia			
CC44PC	7	3%	3%	7	4	2	⅝	2	⅝	1465	15310	I12, L4, F11
CC46PC	7	3%	5½	11	6½	4	⅝	2	⅝	2800	24060	
CC66PC	7	5½	5½	11	6½	4	⅝	2	⅝	4040	30250	
CC68PC	7	5½	7½	11	6½	4	⅝	2	⅝	4040	37810	
CC88PC	3	7½	7½	13	8	4	¾	2	¾	7440	54600	

- Allowable loads have been increased 60% for wind or earthquake loading with no further increase allowed; reduce where other loads govern.
- Post sides are assumed to lie in the same vertical plane as the beam sides.
- Downloads are determined using F_C perpendicular equal to 625 psi on seat area; reduce where end bearing value of post, L/R of post, or other criteria are limiting.
- See page 60 for glulam beam sizes and end conditions. Add PC to the model, i.e. CC3¼-4PC.
- Column caps for end conditions available to order, add an "E" to the start of the model number. See page 69 for load values.

BEAM HANGERS

MATERIAL:
Top flange—7 ga,
Stirrups—7 ga.

Model No.	Dimensions				Bolts				Allowable Loads						Code Ref.
	W	Min. H	TF	Header		Joist		Without Top Flange		No Triangle Theory		Triangle Theory			
				Qty	Dia	Qty	Dia	(100)	(125)	(100)	(125)	(100)	(125)		
LEG3PC	3¼	9	2½	4	¾	2	¾	3465	4330	12675	13215	11865	12730	I19, L14, F18	
LEG5PC	5¼	9	2½	4	¾	2	¾	3465	4330	16290	16290	11865	12730		
MEG5PC	5¼	9	2½	6	¾	2	¾	5170	6460	19710	19710	13570	14865		
LEG7PC	6¾	9	2½	4	¾	2	¾	3465	4330	16290	16290	11865	12730		
MEG7PC	6¾	9	2½	6	¾	2	¾	5170	6460	19710	19710	13570	14865		

- Allowable loads assume a 5½" carrying member.
- Specify desired height, minimum height listed in the table.
- Glulam widths listed in table. To specify other widths add an X to the name and specify.
- See Glulam Connectors section of this catalog for additional information on these products.
- Refer to page 104 footnote #4 For triangle theory explanation.

ARCHITECTURAL PRODUCTS GROUP

RUSTIC COLLECTION

MATERIAL: As noted in tables

FINISH: Textured powder-coated flat black paint

INSTALLATION: • Use all specified fasteners. See General Notes.

CODES: See page 12 for Code Reference Key Chart.

STRAP TIES

Model No.	Ga	Dimensions		Bolts		Allowable Loads ^{1,2}		Code Ref.
		W	L	Qty	Dia	Tension/Uplift (160)		
OS	12	2	12	4	½	1565		170
OHS	7	2½	12	4	⅝	2015		
OHS135	7	6	13½	4	¾	5045		
OHS195	7	6	19½	8	¾	10085		

1. Allowable loads have been increased 60% for wind or earthquake loading with no further increase allowed; reduce where other loads govern.
2. Allowable loads are based on parallel-to-grain loading and a minimum member thickness of 3½" with machine bolts in single shear. Straps must be centered about splice joint and bolt edge distances must meet NDS minimum requirements.
3. Designer must determine allowable loads when combining bolts parallel and perpendicular to grain.

BEAM-TO-COLUMN TIES

Model No.	Ga	Dimensions			Minimum Bolt End & Edge Distances		Bolts		Allowable Loads ^{1,2,3}		Code Ref.
		W	H	L	d ₁	d ₂	Qty	Dia	Tension/Uplift (100/160)	F ₁ (100/160)	
OL	12	2	12	12	2	3½	5	½	1435	565	170
OHL	7	2½	12	12	2½	4⅝	5	⅝	1535	565	
OT	12	2	12	12	2	3½	6	½	2585	815	
OHT	7	2½	12	12	2½	4⅝	6	⅝	2585	815	

1. OL, OHL, OT and OHT must be installed in pairs with machine bolts in double shear. A single part with machine bolts in single shear is not load-rated.
2. Allowable loads are based on a minimum member thickness of 3½".
3. OT, OHT loads assume a continuous beam.

HEAVY ANGLES

Model No.	Ga	Dimensions		Bolts		Code Ref.
		W	L	Qty	Dia	
OHA33	7	3½	3	2	¾	180
OHA36	7	3½	6	4	¾	

COLUMN BASES

Model No.	Ga	Dimensions		Bolts		Allowable Uplift Loads (160)	Code Ref.
		W ₁	W ₂	Qty	Dia		
OCB44	3	3¾	3½	2	⅝	4200	170
OCB46	3	3¾	5½	2	⅝	4200	
OCB48	3	3¾	7½	2	⅝	4200	
OCB66	3	5½	5½	2	⅝	4200	
OCB68	3	5½	7½	2	⅝	4200	
OCB88	3	7½	7½	2	¾	6650	
OCB810	3	7½	9½	2	¾	6650	

COLUMN CAPS

Model No.	Ga	Dimensions				Bolts				Allowable Loads		Code Ref.
		W ₁	W ₂	L	H	Beam		Post		Uplift (160)	Down (100)	
OCC44	3	3⅝	3⅝	9	4½	2	⅝	2	⅝	1465	15310	170
OCC46	3	3⅝	5½	12	7½	4	⅝	2	⅝	2800	24060	
OCC66	3	5½	5½	12	7½	4	⅝	2	⅝	4040	30250	
OCC68	3	5½	7½	12	7½	4	⅝	2	⅝	4040	37810	
OCC88	3	7½	7½	15	7½	4	¾	2	¾	7440	54600	

1. Allowable uplift loads have been increased 60% for wind or earthquake loading with no further increase allowed; reduce where other loads govern.
2. Downloads are determined by nominal sawn beam allowable bearing at 625 psi on seat area; reduce where shear value of beam, end bearing value of post, L/R of post, or other criteria are limiting.
3. Post sides are assumed to lie in the same vertical plane as the beam sides.
4. For end conditions specify OECC.

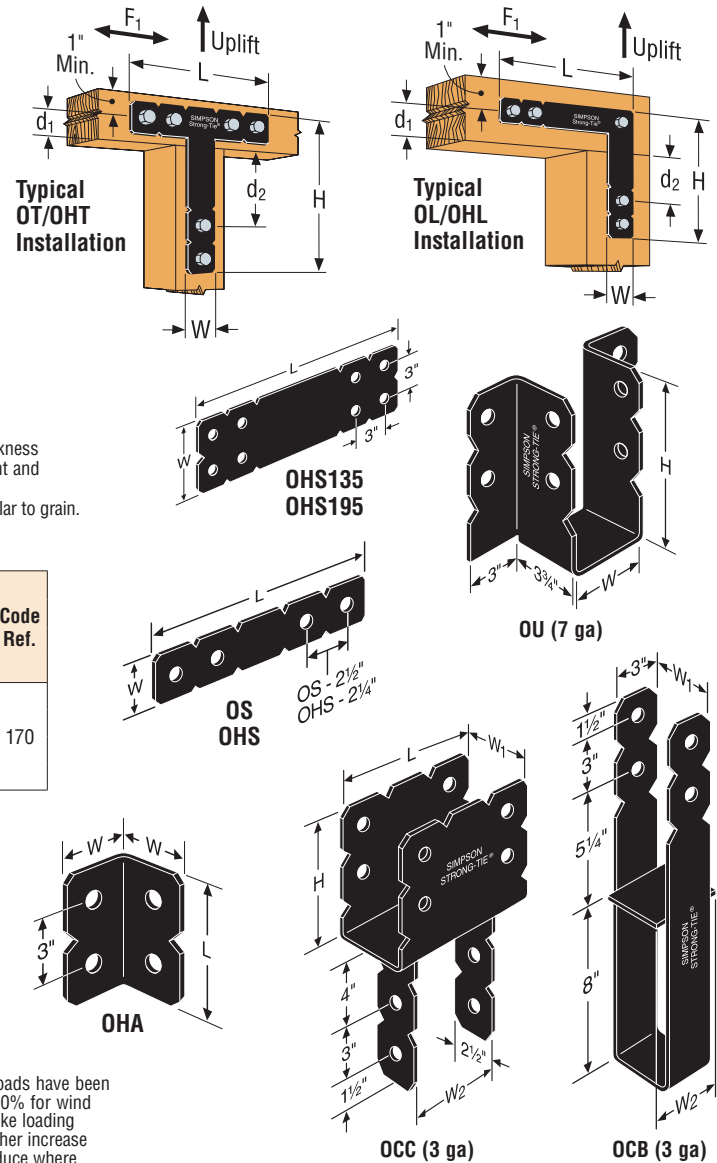

1. Allowable loads have been increased 60% for wind or earthquake loading with no further increase allowed; reduce where other loads govern.
2. Minimum side cover for full loads is 3" for CB's.
3. Install with bottom of base flush with concrete.
4. Post bases do not provide adequate resistance to prevent members from rotating about the base and therefore are not recommended for non top-supported installations (such as fences or unbraced carports).

JOIST HANGERS

Model No.	Ga	Dimensions		Bolts		Allowable Loads ^{1,2}			Code Ref.
		W	H	Header	Joist	Uplift (160)	Floor (100)	Roof ² (125)	
OU46	7	3¾	5	2-¾	1-¾	685	1270	1590	170
OU48	7	3¾	7	4-¾	2-¾	1365	2545	3175	
OU410	7	3¾	9	4-¾	2-¾	1365	2545	3175	
OU412	7	3¾	11	6-¾	3-¾	2050	3815	4765	
OU414	7	3¾	13	6-¾	3-¾	2050	3815	4765	
OU68	7	5½	7	4-¾	2-¾	1365	2545	3175	
OU610	7	5½	9	4-¾	2-¾	1365	2545	3175	
OU612	7	5½	11	6-¾	3-¾	2050	3815	4765	
OU614	7	5½	13	6-¾	3-¾	2050	3815	4765	
OU810	7	7½	9	4-¾	2-¾	1365	2545	3175	
OU812	7	7½	11	6-¾	3-¾	2050	3815	4765	
OU814	7	7½	13	6-¾	3-¾	2050	3815	4765	

1. Load values allowed assume a carrying member of not less than 3½".
2. Roof loads are 125% of floor loads unless a limited by other criteria. Floor loads may be adjusted for other load durations according to the code provided they do not exceed those in the roof column.
3. Additional glulam beam widths are available. Add an "X" to the name and specify width, i.e. OU68X, W = 5.25.
4. Skew and slope options not available.

ARCHITECTURAL PRODUCTS GROUP

STANDOFF BASES

The **PBV** is a hidden standoff post base. Two different sizes fit a variety of posts shapes.

MATERIAL: 14 gauge galvanized steel

FINISH: Textured powder-coated flat black paint or galvanized

ORDER: For powder-coated flat black, order PBV6PC or PBV10PC.

For galvanized coating, order PBV6 or PBV10. For kit containing Simpson Strong-Tie® Strong-Drive® SDS Heavy-Duty Connector screws, RFB bolt, SET® Epoxy Anchoring adhesive, and powder-coated PBV, order PBV6KT or PBV10KT.

The **CPS** is a Composite Plastic Standoff designed for increased concrete surface area.

MATERIAL: Engineered composite plastic

INSTALLATION: PBV and CPS

Post:

- Drill a 3/4" diameter hole, 10" into the center of the post.
- Clean out dust. Fill hole halfway with Simpson Strong-Tie® SET Epoxy Anchoring adhesive.
- Insert all-thread rod and allow epoxy to set and cure.
- Secure standoff to post using four 10d nails except PBV which uses four Simpson Strong-Tie Strong-Drive SDS Heavy-Duty Connector screws.

Concrete:

- Drill a 3/4" diameter hole per anchor design (see footnote 2 below).
- Clean out dust. Fill hole halfway with Simpson Strong-Tie SET Epoxy Anchoring adhesive. Insert post subassembly into hole and allow epoxy to set and cure.
- Post bases do not provide adequate resistance to prevent members from rotating about the base and therefore are not recommended for non top-supported installations (such as fences or unbraced carports).

CODES: See page 12 for Code Reference Key Chart.

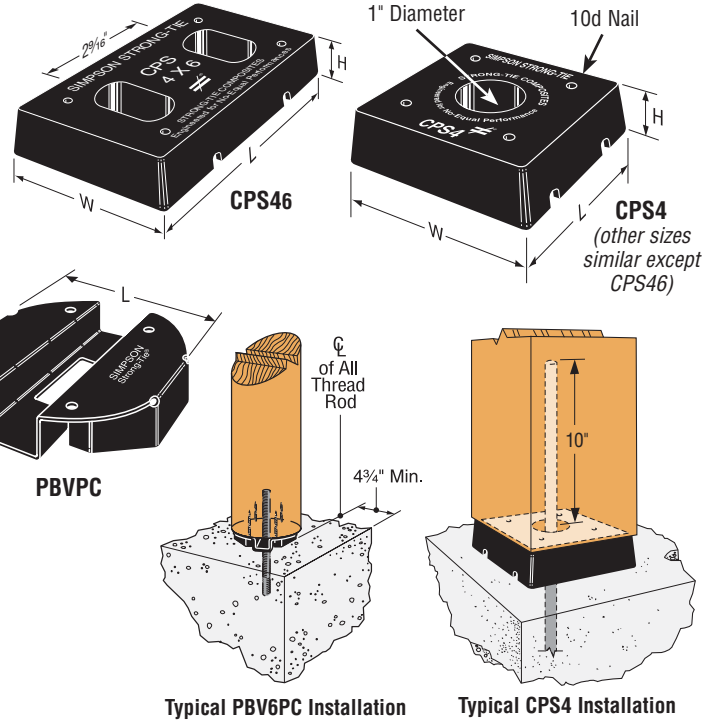

Model No.	Post or Column Size	Dimensions			Fasteners		Allowable Loads		Code Ref.
		L	W	H	Post	Anchor Bolt	Uplift	Down ^s	
CPS4	4x4	3 3/4	3 3/4	1	4-10d	5/8"	4490	5195	170
CPS46	4x6	5 5/16	3 3/16	1	4-10d	2-5/8"	4490	5865	
CPS5	5x5	4 1/8	4 1/8	1	4-10d	5/8"	4490	5865	
CPS6	6x6	5 5/16	5 5/16	1	4-10d	5/8"	4490	7745	
CPS7	8x8	7 1/4	7 1/4	1 1/4	4-10d	5/8"	4490	8315	
PBV6PC	6" Dia	5 1/4	—	1	4-SDS 1/4x3	5/8"	3800	9250	
PBV10PC	10" Dia	9 3/16	—	1	4-SDS 1/4x3	5/8"	3800	19225	

1. Allowable uplift load capacities are for solid sawn posts with specific gravity of 0.36 minimum except the PBV, which is based on round "Viga" (Ponderosa Pine) wood posts.
2. All allowable uplift loads are based on a lowest ultimate load from testing divided by a safety factor of 4. Concrete anchorage to be designed by others, refer to Simpson Strong-Tie® Anchoring and Fastening Systems for Concrete and Masonry catalog (form C-SAS). Allowable uplift capacities shall not exceed those shown in the table.
3. Download capacities are calculated based on the standoff bearing area and a concrete strength of 2500 psi except the PBV, which is based on the wood bearing strength (700 psi for Ponderosa Pine).
4. Allowable loads may not be increased for short term loading.
5. **NAILS:** 10d = 0.148" dia. x 3" long.
See pages 22-23 for other nail sizes and information.

HL – HEAVY ANGLES & GUSSETS

Versatile angle gussets and heavy angles promote standardization and construction economy, and are compatible with Simpson Strong-Tie® structural hardware.

FINISH: Textured powder-coated flat black paint, Simpson Strong-Tie® gray paint and also available galvanized

TO ORDER: All products with PC suffix are textured powder-coated flat black paint. 7 gauge products without the PC suffix are galvanized. 3 gauge products without the PC suffix are Simpson Strong-Tie gray paint.

OPTIONS: Gussets may be added to HL models when L ≥ 5". Specify G after numbers in model number as in HL46GPC.

CODES: See page 12 for Code Reference Key Chart.

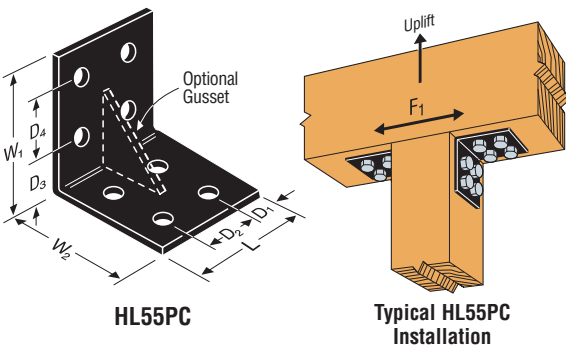

Model No.	Ga	Dimensions							Bolts (Total)		Allowable Loads		Code Ref.
		W1 & W2	L	D1	D2	D3	D4	Qty	Dia	Uplift	F1		
HL33PC	7	3 3/4	2 1/2	1 1/4	—	2	—	2	1/2	910	1580	170	
HL35PC	7	3 3/4	5	1 1/4	2 1/2	2	—	4	1/2	910	1580		
HL37PC	7	3 3/4	7 1/2	1 1/4	2 1/2	2	—	6	1/2	910	1580		
HL53PC	7	5 3/4	2 1/2	1 1/4	—	2	2 1/2	4	1/2	910	1580		
HL55PC	7	5 3/4	5	1 1/4	2 1/2	2	2 1/2	8	1/2	910	1580		
HL57PC	7	5 3/4	7 1/2	1 1/4	2 1/2	2	2 1/2	12	1/2	910	1580		
HL43PC	3	4 1/4	3	1 1/2	—	2 3/4	—	2	3/4	1555	1580		
HL46PC	3	4 1/4	6	1 1/2	3	2 3/4	—	4	3/4	1555	2025		
HL49PC	3	4 1/4	9	1 1/2	3	2 3/4	—	6	3/4	1555	2025		
HL73PC	3	7 1/4	3	1 1/2	—	2 3/4	3	4	3/4	1555	2025		
HL76PC	3	7 1/4	6	1 1/2	3	2 3/4	3	8	3/4	2115	3800		
HL79PC	3	7 1/4	9	1 1/2	3	2 3/4	3	12	3/4	2115	3800		

1. Allowable loads have been increased 60% for wind or earthquake loading with no further increase allowed; reduce where other loads govern.
2. Use 0.85 times table load for Hem Fir.
3. Parts should be centered on the face of the member to which they are attached.
4. Wood members for the '3' and '5' series must have a minimum width and thickness of 3 1/2" for table loads to apply.
5. Wood members for the '4' and '7' series must have a minimum width and thickness of 5 1/2" for table loads to apply.
6. Parts must be used in pairs. Lag bolts of equal diameter (minimum 5" long) may be substituted for machine bolts into beam with no reduction in load.

HANGER OPTIONS GENERAL NOTES

HANGER MODIFICATION OPTIONS AND APPLICATIONS

The Hanger Options Matrix for Face Mount and Top Flange Hangers on pages 234-235 shows hanger modifications and special applications (*uplift, nailers and weldability*) that are available for each model series. Modifications may not be available for all models in the series, and some combinations of hanger options are not available. Many hanger modifications result in load reductions. For all modifications, refer to the listed hanger option pages for additional information regarding the availability of each modification, associated load reductions, and installation requirements. For more information regarding the applications, refer to the individual product pages throughout the catalog.

HANGER OPTIONS GENERAL NOTES

This information applies only to the hangers manufactured by Simpson Strong-Tie and installed per our instructions. Some combinations of these options on a single hanger have not been evaluated. In some cases, combinations of these options cannot be manufactured. A qualified Designer must always evaluate each connection, including header and joist limitations, before specifying the product.

Testing is performed using a standardized hanger test method. The joist in the test setup may include the minimum amount of structural stability where appropriate. For example, the sloped down hanger tests are assembled with a joist cut on the lower end to lie flush with a wood member attached with three 8d common toenails. Header and other attached structural members are assumed fixed in actual installations. Horizontal loads induced by sloped joists must be resisted by other members in the structural system.

MATERIAL: Gauge may vary from that specified depending on the manufacturing process used. U, HU, HUTF, W and B hangers normally have single-piece stirrups; occasionally, the seat may be welded. Hanger configurations, height and fastener schedules may vary from the tables depending on the joist size, skew and slope.

FINISH: See specific hanger tables. Welded specials: Simpson Strong-Tie® gray paint. Specials that are not galvanized before fabrication can be hot-dip galvanized after fabrication; specify HDG.

CODES: Modified hangers, due to their numerous variations, are not on code reports.

LOADS: For multiple modifications on the same connector, use the single multiplier factor that yields the lowest design loads.

TO ORDER: Use the abbreviations below to order specials. The example shows a W410 hanger and illustrates most available options; most special hangers have only a few of these features. For assistance, contact Simpson Strong-Tie.

INSTALLATION:

- Fastener quantities may be increased beyond the amount specified in the standard hanger table.
- Fill all holes with the table-specified fastener types.
- Some skewed hangers require bevel cut joists; refer to the specific notes provided for each product.

W410	X	SLD30	SKL20	TFDL20	TFO20	OSR
Base Model		Seat Sloped Down (30°) <i>(SLU = Seat Up)</i>	Skewed Left (20°) <i>(SKR = Skewed Right)</i>	Top Flange Down Left (20°) <i>(TFDR = Top Flange Down Right)</i>	Top Flange Open (20°) <i>(TFC = Top Flange Closed)</i>	Offset Top Flange Right <i>(OSL = Offset Top Flange Left)</i>
X = Modification						

The new Joist Hanger Selector software enables you the most optimum product for your project. The software takes into consideration all the characteristics seen in this catalog. Visit www.strongtie.com/jhs.

HEIGHT FOR SLOPED HANGERS

Height 1 (H1) is the joist height before the slope cut has been made.

Net Height (Net H) is the joist height after the slope cut has been made.

Provide **H1** when ordering a connector. Connectors are made assuming dry lumber is being used in continuously dry conditions.

Simpson Strong-Tie will calculate the **Net H** dimension based on the mathematical formula of $H1/\cos$ angle.

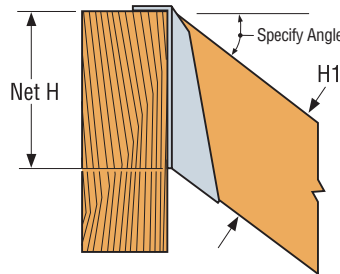

FACE-MOUNT HANGER OPTION MATRIX

BASE MODEL SERIES	HANGER MODIFICATION OPTIONS						APPLICATIONS		HANGER OPTION PAGE(S)	
	SKEWED SEAT		SLOPED SEAT	SKEWED & SLOPED SEAT	CONCEALED FLANGE(S)	ALTERNATE WIDTHS	UPLIFT WELDABILITY			
	ALLOWABLE SKEW	SQUARE CUT JOIST ALLOWED					Uplift	Weldable		
FACE MOUNT HANGERS										
HGU	≤ 45°	See Note 4			●	●	U		243	
HGUM	≤ 45°	See Note 4			●	●	U		243	
HGUQ							U		—	
HGUS	≤ 45°	●					U		237	
HHGU					●	●	U		243	
HHUS	≤ 45°		≤ 45°	●			U		237	
HSUL/HSUR	45° Std.	●			●		U		—	
HSULC/HSURC	45° Std.	●			Std.		U		—	
HTU	≤ 67½°	●					U		237	
HU	≤ 67½°	●	≤ 45°	●	●	●	U, W		236	
HUC	See Note 3	●	≤ 45°		Std.		U, W		236	
HUCQ					Std.		U		—	
HUSC					Std.		U		—	
IUS							U		—	
LGU	≤ 45°	●			●	●	U		243	
LGUM	≤ 45°	See Note 4					U		243	
LSU/LSSU	Field skewable and slopeable to 45° available for some models							U		—
LTHJA							U		—	
LTHMA							U		—	
LU							U		—	
LUC					Std.		U		—	
LUS							U		—	
MGU	≤ 45°	See Note 4			●	●	U		243	
MIU							U		—	
MUS							U		—	
SUL/SUR	45° Std.	●					U		—	
SULC/SURC	45° Std.	●			Std.		U		—	
THGB/THGBH/ THGBV/THGBHV	≤ 45°	See Note 4					U		238	
THGQH	45°	●					U		238	
THJA							U		—	
THJU						●	U		237	
U	≤ 67½°	●	≤ 45°	●			U		236	

1. Refer to the specific product pages for uplift, nailer, and weld information.
2. Refer to the listed pages for each model series for restrictions, required load reductions, and additional information regarding the hanger modifications.
3. HUC less than 3¼" wide cannot be skewed 45°. See page 236 for allowable skews for narrower widths.
4. Square cut allowed for beams up to 5½" and 4-ply trusses.

● = Available for all models ● = Available for some models Std. = Available with standard model (no modification required)

UPDATED 03/27/15

TOP-FLANGE HANGER OPTION MATRIX

BASE MODEL SERIES	HANGER MODIFICATION OPTIONS											APPLICATIONS		HANGER OPTION PAGE(S)	
	SKEWED SEAT		SLOPED SEAT	SKEWED & SLOPED SEAT	CONCEALED FLANGE(S)	ALTERNATE WIDTHS	SLOPED TOP FLANGE	OPEN TOP FLANGE	CLOSED TOP FLANGE	OFFSET TOP FLANGE	SADDLE HANGER	RIDGE HANGER	UPLIFT NAILERS		WELDABILITY
	ALLOWABLE SKEW	SQUARE CUT JOIST ALLOWED													
B	≤ 45°		≤ 45°	●		●	●	●	●				U, N, W	240	
BA													U, N, W	—	
EG	≤ 45°		≤ 45°										—	242	
EGQ	≤ 45°		≤ 45°										U	242	
GB			≤ 45°								●		U, W	240	
GH	≤ 45°										●		—	238	
GLS	≤ 50°		≤ 45°	●			●			●	●		U, W	239	
GLT	≤ 50°		≤ 45°	●			●			●			U, W	239	
GLTV	≤ 50°		≤ 45°	●			●			●			U, N, W	239	
HB	≤ 45°		≤ 45°	●		●	●	●			●		U, N, W	240	
HGB			≤ 45°								●		U	240	
HGLS	≤ 50°		≤ 45°				●			●	●		U, W	239	
HGLT	≤ 50°		≤ 45°				●			●			U, W	239	
HGLTV	≤ 50°		≤ 45°				●			●			U, W	239	
HHB			≤ 45°			●					●		U, W	240	
HIT													U, N	—	
HUCTF			≤ 45°		Std.								U	242	
HUSCTF/HUCITF					Std.								—	—	
HUTF/HUITF	≤ 45°	●	≤ 45°	○	○								U	242	
HW/HWI	≤ 84°	●	≤ 45°	●			●	●		●	●	○	N, W	241	
HWU	≤ 45°	○	≤ 45°	○									U, N, W	241	
ITS													U, N	—	
LB													U, N, W	—	
LBAZ													U, N, W	—	
LBV	≤ 45°		≤ 45°	●		●	●	●			●		U, N, W	240	
LEG	≤ 45°	●	≤ 45°							●			—	242	
MBHA	45°	●											—	242	
MEG	≤ 45°	●	≤ 45°							●			—	242	
MIT													U, N	—	
MSC	20°-45°	●	≤ 45°	●		○							—	—	
MSCPT	25°-45°	●				○							U	—	
PF													U	—	
THA					○								U, N	—	
THAC					Std.								U, N	—	
THAI													N	—	
THAR/L	45° Std.	●											U, N	—	
THASR/L	22°-75° Field Skewable	●											U	—	
W/WI	≤ 84°	○	≤ 45°	●			●	●	●	●	●	○	N, W	241	
WM/WMI	≤ 45°		≤ 45°	●						●			—	235	
WNP/WP/WPI	≤ 84°	○	≤ 45°	●			●	●	●	●	●	○	N, W	241	
WPU/WNPU	≤ 45°	●	≤ 45°	○									U, N, W	241	

See footnotes on page 234.

● = Available for all models ○ = Available for some models Std. = Available with standard model (no modification required)

HANGER OPTIONS

U/HU

See Hanger Options General Notes.

Not all slope and skew combinations are available.

SLOPED, SKEWED, AND SLOPED/SKEWED

- For low-cost, code-reported 45° skews, see SUR/SUL and HSUR/HSUL. See also LSU/LSSU connectors.
- These options only apply to wood-to-wood connections.
- U/HU may be skewed to a maximum of 45° and sloped to a maximum of 45°. Hangers 5½" or less in width may be skewed to 67½°. Hangers skewed 51° - 67½° require a square cut.
- For all options, uplift loads are 0.75 of table loads.
- For skewed hangers 3⅞" and less in width, the allowable download is 100% of the table load. For skewed hangers over 3⅞" in width the allowable download is 80% of the table load. For slope only, the allowable download is 100% of the table load.
- For combined slopes and skews, the maximum allowable download is 0.80 of the table load.
- Skewed hangers may have joist nails only on one side.

STRAIGHT OR CONCEALED FLANGE

- HU is available with the A flanges straight at 100% of the table loads if $W \geq 3\frac{1}{2}"$.
 - If $W < 3"$, use N10 nails at 0.64 of the table load.
 - If $W \geq 3"$, use 10d nails at 0.84 of the table load.
- HU is available with A flanges concealed, provided the W dimension is 2⅝" or greater, at 100% of the table load. Specify HUC.
- HU is available with one flange concealed when the W dimension is less than 2⅝" at 100% of the table load.
- For skewed only HUC hangers, the flange on the acute side can be concealed at 100% of the table load. See table for skew limitations.
- For sloped only hangers, flanges can be concealed at 100% of the table load.
- For sloped and skewed hangers, the flange on the acute side can be concealed at 0.80 of the table load. Contact Simpson Strong-Tie for skew limitations.
- When nailing into the carrying member's end grain, the allowable load is 0.67 of the table load.
- For welding see technical bulletin T-HUHUC-W.

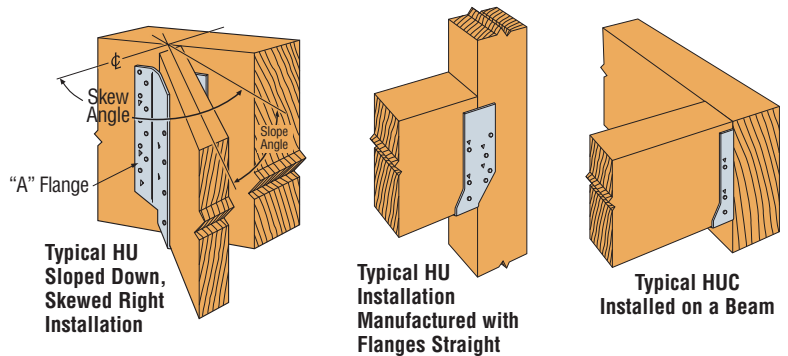

Maximum Skew Degree for Skewed HUC Hangers

Hanger Width (in.)	Maximum Skew (degree)
2⅝	31
2¾	31
2⅞	34
3	37
3⅞	41
3¼	42

1. Widths greater than 4⅝" maximum skew is 45°.

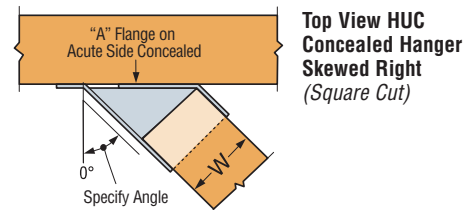
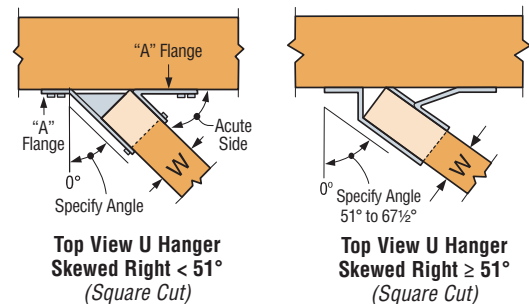

WM/WMI/WMU

See Hanger Options General Notes.

INSTALLATION: • Bevel-cut the joist for skewed hangers (see illustration).

HANGER HEIGHT

- For hanger heights exceeding the joist height, the allowable load is 0.50 of the table load.

SLOPED AND/OR SKEWED SEAT

- WM/WMI may be skewed and/or sloped to 45° maximum.
- The allowable load is 100% of the table load.

OFFSET TOP FLANGE

- The top flange may be offset left or right for placement at the end of a header. The allowable load is 0.50 of the table roof load.

UPLIFT (WMU Only)

- No modifications on WMU.

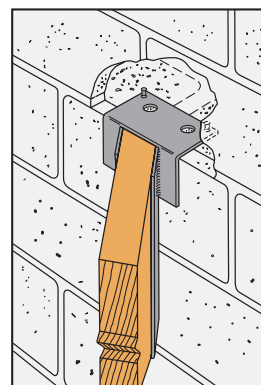

Typical WM Sloped Down, Skewed Right Block Wall Installation

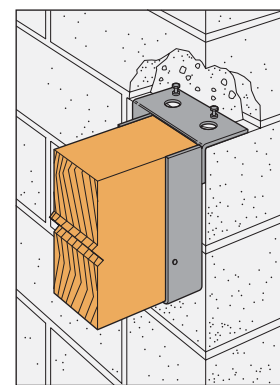

Typical WM Top Flange Offset Left

HANGER OPTIONS

HTU

See Hanger Options General Notes.

SKEWED SEAT

- Skewable up to 67½°.
- Available in single and 2-ply size.
- No bevel cut required.

Allowable Loads for Skewed HTU Hangers

Model No.	Skew Angle (Degree)	Fasteners		DFL/SP Allowable Loads ^{1,2}		HF/SPF Allowable Loads ^{1,2}	
		Carrying Member	Carried Member	Uplift (133/160)	Download (100/115/125)	Uplift (133/160)	Download (100/115/125)
HTU26	< 51	20-16d	14-10dx1½	1315	2945	1130	2530
	51-67½	20-16d	12-10dx1½	970	2595	835	2230
HTU28	< 51	26-16d	20-10dx1½	2015	3060	1730	2630
	51-67½	26-16d	17-10dx1½	1485	2815	1280	2420
HTU210	< 51	32-16d	26-10dx1½	2715	3175	2335	2730
	51-67½	32-16d	22-10dx1½	2005	3040	1725	2615
HTU26-2	< 51	20-16d	14-10d	1335	2555	1145	2200
	51-67½	20-16d	12-10d	1110	2700	955	2320
HTU28-2	< 51	26-16d	20-10d	2470	3890	2120	3345
	51-67½	26-16d	17-10d	1710	3775	1470	3245
HTU210-2	< 51	32-16d	26-10d	3600	4935	3100	4245
	51-67½	32-16d	22-10d	2255	4790	1940	4120

1. Uplift loads have been increased for wind or earthquake loading with no further increase allowed. Reduce where other loads govern.
2. Allowable downloads may not be increased.
3. Maximum hanger gap between end of joist (*truss*) and face of carrying member is ¼".
4. **NAILS:** 16d = 0.162" dia. x 3½" long, 10dx1½ = 0.148" dia. x 1½" long, 10d = 0.148" dia. x 3" long. See pages 22-23 for other nail sizes and information.

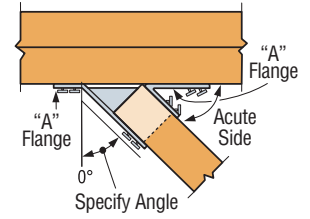

Top View HTU Hanger Skewed Right < 51°

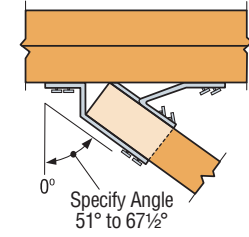

Top View HTU Hanger Skewed Right ≥ 51°

HGUS/HHUS

See Hanger Options General Notes.

HHUS – SLOPED AND/OR SKEWED SEAT

- HHUS hangers can be skewed to a maximum of 45° and/or sloped to a maximum of 45°.
- For skew only, maximum allowable download is 0.85 of the table load.
- For sloped only or sloped and skewed hangers, the maximum allowable download is 0.65 of the table load.
- Uplift loads for sloped/skewed conditions are 0.72 of the table load, not to exceed 2475 lbs.
- The joist must be bevel-cut to allow for double shear nailing.

HGUS – SKEWED SEAT

• HGUS hangers can be skewed only to a maximum of 45°. Allowable loads are:

HGUS Seat Width	Joist	Down Load	Uplift
W < 2"	square cut	0.62 of table load	0.46 of table load
W < 2"	bevel cut	0.72 of table load	0.46 of table load
2" < W < 6"	bevel cut	0.85 of table load	0.41 of table load
2" < W < 6"	square cut	0.46 of table load	0.41 of table load
W > 6"	bevel cut	0.85 of table load	0.41 of table load

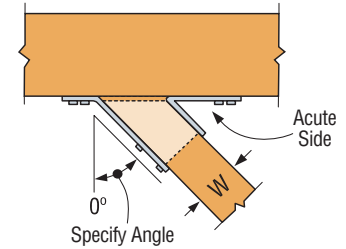

Top View HHUS Hanger Skewed Right (joist must be bevel cut)
All joist nails installed on the outside angle (*non-acute side*).

THJU

See Hanger Options General Notes.

HANGER WIDTHS

- THJU is available in intermediate seat widths between 5½" (*THJU26 width*) and 8½" (*THJU26-W width*).
- Allowable download and uplift for all intermediate widths is 100% of the THJU26-W table loads.
- For double hip installation, divide the total allowable load by 2 to determine the allowable load for each hip.
- Order as THJU26X and specify width; see table for reference.

THJU Intermediate Width Options

Carried Member Combination	Hip Skew	Width (W)
2-Ply Hip and Single-Ply Jack	45°	6¾"
Single-Ply Hip and 2-Ply Jack	45°	6¾"
Double (Terminal) Hip	45°	7"
2-Ply Hip and 2-Ply Jack	45°	Use THJU26-W
	44°-46°	Use THJU26
	47°-49°	5½"
	50°-52°	5¾"
	53°-55°	6"
	56°-57°	6¾"
	58°-59°	6¾"
	60°-61°	7"
	62°-63°	7¾"
64°-65°	Use THJU26-W	

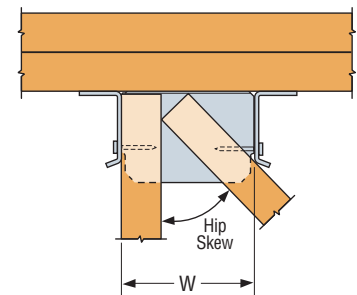

THJU Top View Installation

HANGER OPTIONS

THGQH

See Hanger Options General Notes.

SKEWED SEAT

- THGQH may be skewed 45° for the models shown. Carried members may be bevel cut.
- For Hem-Fir or Spruce-Pine-Fir members, multiply tabulated allowable loads for the skewed THGQH by 0.86. Connector must be installed centered on girder vertical webs.

Model #	Max. B.C. Depth (in.)	Min. Vertical Web Size	Fasteners		DF/SP Allowable Loads	
			Face	Joist	Uplift (160)	Down (100/115/125)
THGQH2 SK45	17	2x6	18-1/4"x3" SDS	18-1/4"x3" SDS	4570	6090
		2x8	28-1/4"x3" SDS	18-1/4"x3" SDS		9470
THGQH3 SK45	14	2x8	30-1/4"x4 1/2" SDS	18-1/4"x4 1/2" SDS	3875	10270
		2x10	36-1/4"x4 1/2" SDS			12480
THGQH4 SK45	13	2x8	34-1/4"x6" SDS	18-1/4"x6" SDS	3180	11890
		2x10	40-1/4"x6" SDS			13990

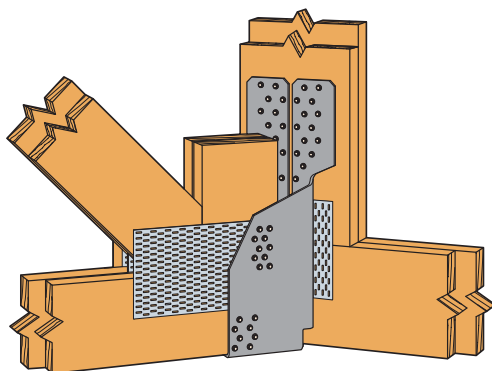

Typical THGQH2 SK45 Installation Skewed Left

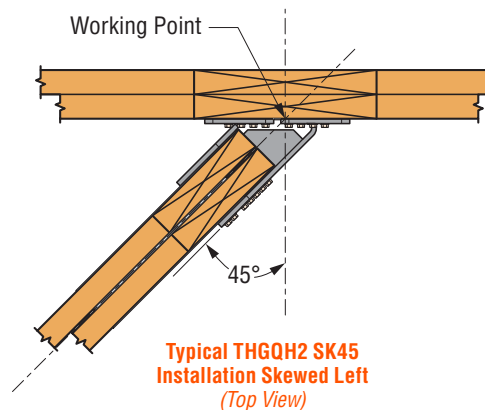

Typical THGQH2 SK45 Installation Skewed Left (Top View)

THGB/THGBH/THGBV/THGBHV

See Hanger Options General Notes.

SKEWED SEAT

- THGB/THGBH/THGBV/THGBHV hangers can be skewed to a maximum of 45°.
- The maximum allowable down load and uplift load for skew is 0.87 of the table load.

DROPPED BUCKET

- THGBV/THGBHV backplates can be extended to allow for up to a 6" dropped bucket.
- Allowable loads are 100% of the table loads.
- Order as "X" version, specify the total backplate height, BK_PLT, equal to the hanger height (H) plus the dropped bucket amount (db).
Ex: a THGBV3.62/9 with a 4" dropped bucket would have a total backplate height of 27 1/4".

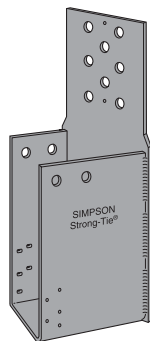

THGBH3 (Skewed Left)

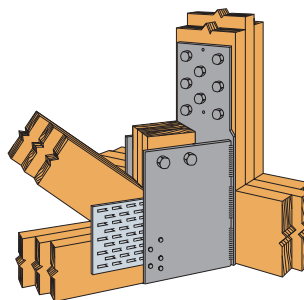

Typical THGBH Installation Skewed Left

GH Girder Hanger

See Hanger Options General Notes.

SKEWED SEAT

- GH hangers may be skewed to a maximum of 45°; bevel cut required.
- The allowable loads are 100% of the table load.
- Specify GHD for saddle-style hangers. GHD may not be skewed.

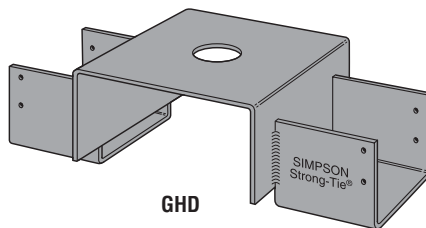

GHD

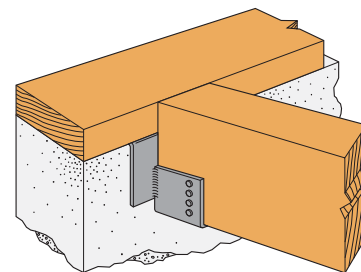

Typical GH Installation Skewed Right

HANGER OPTIONS

GLT/HGLT/GLS/HGLS/GLTV/HGLTV

See Hanger Options General Notes.

INSTALLATION: • Bevel-cut the carried beam for skewed hangers.

HANGER HEIGHT

- For hangers exceeding the joist height by 1/2", allowable load is 50% of the table roof load.

SLOPED AND/OR SKEWED SEAT

- GLT/GLTV/HGLT/HGLTV and GLS/HGLS series may be skewed to a maximum of 50° or sloped to a maximum of 45°.
- For skews greater than 15°, multiply the table uplift load by 0.50.
- For sloped only, the maximum allowable load is 6500 lbs. for the GLT/GLS/GLTV, 9165 lbs. for the HGLT/HGLS/HGLTV.
- For skewed only, the maximum allowable load is 6550 lbs. for the GLT/GLS/GLTV, 7980 lbs. for the HGLT/HGLS/HGLTV. The deflection at full loading may reach 1/4".
- Sloped and skewed GLT/GLS/GLTV configurations have a maximum allowable load of 5500 lbs. Sloped and skewed combinations are not allowed for the HGLT/HGLS/HGLTV.
- Sloped and/or skewed seat hangers may not be installed in non-backed nailer/header installations.

SLOPED TOP FLANGE

- A top flange may be sloped down left or down right to 30° with or without a sloped and/or skewed seat (see illustration). Reduce allowable table loads using straight-line interpolation (see page 241).

OFFSET TOP FLANGE

- The top flange may be offset left or right for placement at the end of a header. Minimum seat width 3 1/4". The maximum allowable load is 0.50 of the table load for the GLT/GLS/GLTV, and 0.45 for the HGLT/HGLS/HGLTV.
- For skewed and offset top-flange GLS/GLT/GLTV hangers with inward configuration, the maximum allowable load is 3,500 lbs. Outward configuration is not allowed.
- For skewed and offset top-flange HGLS/HGLT/HGLTV hangers with inward or outward configuration, the maximum allowable load is the lesser of a) 45% of the catalog load or b) 4,300 lbs,
- No uplift load.

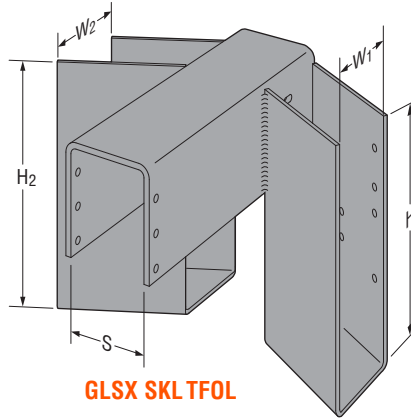

GLSX SKL TFOL

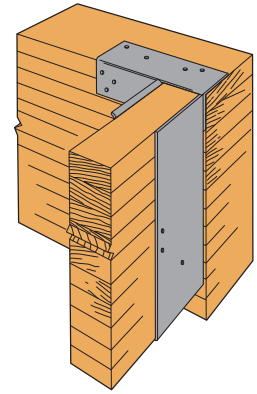

Typical GLT Top Flange Offset Left
(HGLT similar)

GLS (Skewed Inward) Skewed Left, Offset Left (Top View)

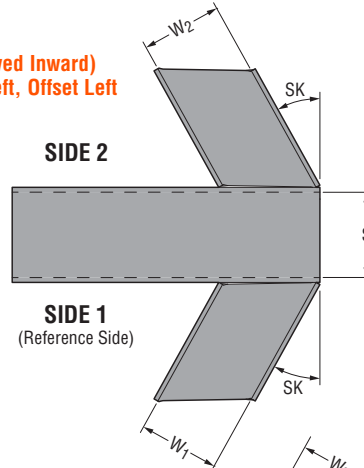

SIDE 2

SIDE 1
(Reference Side)

HGLS (Skewed Outward) Skewed Right, Offset Left (Top View)

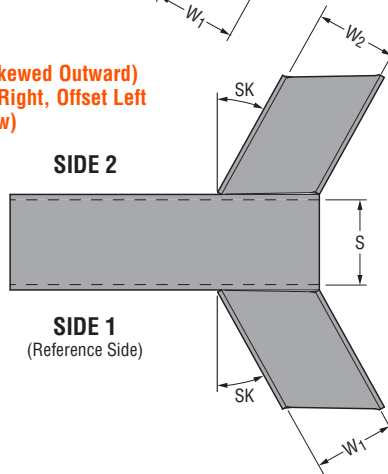

SIDE 2

SIDE 1
(Reference Side)

Specify Low Side, High Side, or Center Flush with Header
(Low Side Flush Shown)

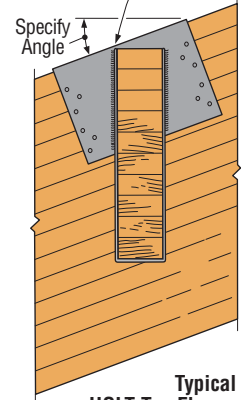

Typical HGLT Top Flange Sloped Down Left with Low Side Flush

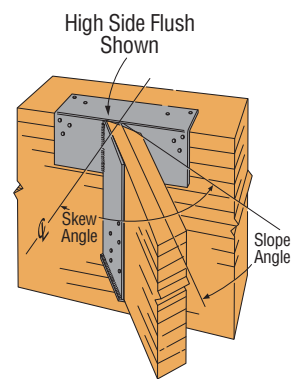
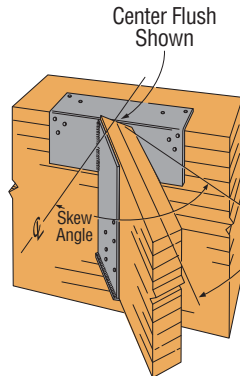
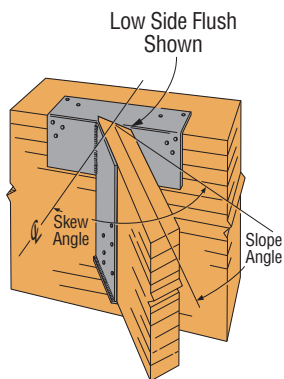

Typical GLT Sloped Down, Skewed Right

When ordering, specify Low Side Flush, Center Flush or High Side Flush

HANGER OPTIONS

B/LBV/HB/HHB/GB/HGB

See Hanger Options General Notes.

MATERIAL:

- Gauge may vary from that specified depending on the manufacturing process used. Hanger configurations, height and fastener schedules may vary from the tables depending on the joist size, skew and slope.

CODES:

- Modified hangers, due to their numerous variations, are not in code reports.

LOADS:

- For multiple modifications on the same connector, use the single multiplier factor that yields the lowest design loads.

INSTALLATION:

- Fastener quantities will typically increase beyond the amount specified in the standard hanger tables.
- Web stiffeners are required for I-joists.
- Fill all holes with the table-specified fastener types.
- Bevel cut the carried member for skewed applications.

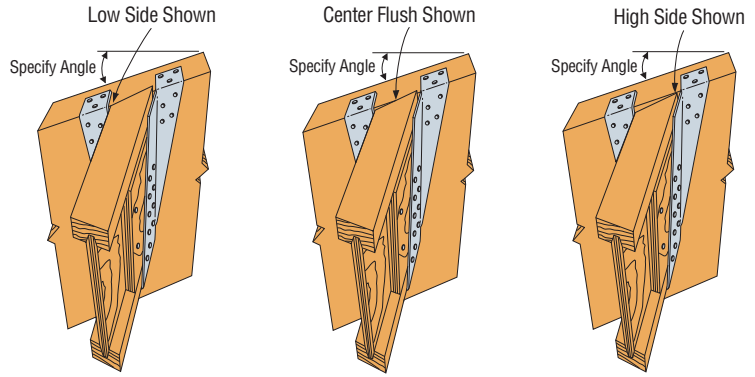

B Hanger Sloped Down and Skewed Left with Sloped Top Flange Installation
When ordering, specify Low Side Flush, Center Flush or High Side Flush

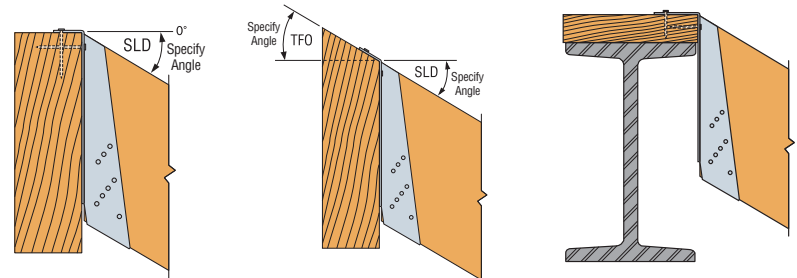

Typical LBV Sloped Down Installation with Full Backing
Typical LBV Sloped Down with Top Flange Open
Typical LBV Sloped Down on Nailers Non-Backed

Reduction Factors for Allowable Loads for Modified Hangers¹

Hanger Series	Condition		Carried Member Modifications						Support Member Modifications ⁵		
			Sloped Down	Sloped Up	Skewed Only	Sloped Down & Skewed	Sloped Up & Skewed	Top Flange Down	Top Flange Open/Closed		
	Angle Limit		45	45	45	45	45	35	30		
LBV	Minimum Height		6	6	6	9¼	14	9¼	14	11¼	9¼
	All Widths	Download	1.00	0.91	1.00	0.90	1.00	0.91	0.91	(90-x)/90	(90-x)/90
		Uplift	1.00	1.00	1.00	1.00	1.00	1.00	1.00	1.00	1.00
B	Minimum Height		6	6	6	9¼	14	9¼	14	14 ⁴	9¼
	Less than 2½" Wide ²	Download	0.82	0.66	0.95	0.54	0.82	0.64	0.64	(90-x)/90	(90-x)/90
		Uplift	1.00	1.00	1.00	0.90	1.00	0.90	1.00	1.00	1.00
	2½" and Wider ³	Download	0.80	0.95	1.00	0.70	1.00	0.80	0.80	(90-x)/90	(90-x)/90
Uplift		1.00	1.00	1.00	1.00	1.00	1.00	1.00	1.00	1.00	
HB	Minimum Height		8	8	8	11¼	14	11¼	14	14 ⁴	11¼
	Less than 2½" Wide ²	Download	0.84	0.70	1.00	0.47	0.84	0.62	0.69	(90-x)/90	(90-x)/90
		Uplift	1.00	1.00	0.71	0.71	0.71	0.71	0.71	1.00	1.00
	2½" and Wider ³	Download	0.87	0.70	0.96	0.59	0.87	0.70	0.70	(90-x)/90	(90-x)/90
Uplift		1.00	1.00	1.00	1.00	1.00	1.00	1.00	1.00	1.00	
HHB GB HGB	Minimum Height		9¼	—	—	—	—	—	—	—	—
	All Widths	Download	0.70	—	—	—	—	—	—	—	—
		Uplift	1.00	—	—	—	—	—	—	—	—

- Use this table to calculate allowable loads for modified hangers. Apply the reduction factor to the appropriate allowable load for the header condition including headers.
- B and HB hangers less than 2½" wide are assumed to use 10dx1½ joist nails.
- B and HB hangers 2½" or wider are assumed to use 16dx2½ or 16d common nails in the joist.
- For B and HB hangers with TF Down that are less than 5⅝" in width, minimum hanger height is 11¼ inches.
- These hangers may deflect an additional ½" at design load.
- For HB hangers on nailers, 100% of allowable nailer uplift value may be used. (See nailer table)
- In the table the term "x" refers to the angle of the modification.
- For top flange closed option, install upper nails slightly angled downward to avoid interference with top flange.

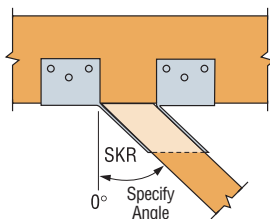

Top View B Hanger Skewed Right

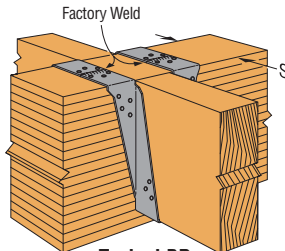

Typical BD Saddle Installation

SADDLE HANGER

Saddle hangers are made to order; add "D" to model (e.g. BD412); specify S (for saddle) dimension. They may be used for most conditions except at end wall locations and are preferred for nailer applications. Minimum S dimension (saddle width) is 3¼". Minimum supporting member width is 3½". Minimum nailer thickness apply (see page 84 and 120). Saddle hangers achieve catalog load listed. Saddle hangers on stud walls do not achieve catalog loads.

HANGER OPTIONS

W/WNP/WNPU/WP/WPU/HW/HWU

See Hanger Options General Notes.

Models that have an "I" in the model number (e.g., HWI) have the same properties and modifications as the standard models without the "I" in the name (e.g., HW).

INSTALLATION: • Some models are available in Type A (*Bevel Cut*) and Type B (*Square Cut*) styles; all models are available in Type B style. Contact Simpson Strong-Tie when ordering.

- Bevel-cut the joist for skewed Type A hangers (*see illustration*).
- Butt-cut the joist for Type B hangers.
- Hangers with a skew greater than 15° may have all the joist nails on the outside angle.
- Skewed HWs have face nails and require a minimum header depth of 3½".

HANGER HEIGHT

- Minimum height may increase significantly with modification. Check availability when ordering.
- For hanger heights exceeding the joist height by more than ½", the allowable load is 0.50 of the table load.

SLOPED AND/OR SKEWED SEAT

- Non-skewed hangers can carry the design load when the seat slope is within ¼:12 of the joist slope. Designer must check that wood bearing is not limiting.
- W/WNP/WP/HW series may be skewed to a maximum of 84° and/or sloped to a maximum of 45°.
- For slope only, skew only, or slope and skew combinations, the allowable load is 100% of the table load.

UPLIFT LOADS (WPU, WNPU, HWU only)

- Uplift loads not available on W, WNP, WP, HW hangers. See page 236 for WMU.
- Hangers can be sloped to 45° and/or skewed 45° at 100% of the uplift load.
- Skew option is only on hangers with "W" 3/16" or less.
- Specify the slope up or down in degrees from the horizontal plane and/or the skew right or left in degrees from the perpendicular vertical plane. Specify whether low side, high side or center of joist will be flush with the top of the header (*see illustration*).
- Uplift loads are not available for open/closed TF, TF sloped, and offset options.

SLOPED TOP FLANGE

- A top flange may be ordered sloped down left or down right to 35° with or without a sloped and/or skewed seat (*see illustration*). Reduce allowable table loads using straight-line interpolation. Example: For a top flange sloped down 30°, reduce load to [(90-30)/90] x table load.

OFFSET TOP FLANGE

- The top flange may be offset left or right for placement at the end of a header (*see illustration*). The allowable load is 0.50 of the table load.
- For skewed and offset top flange hangers, the maximum allowable load is 0.50 of the table load or 2000 lbs., whichever is lower.
- For type B hangers skewed and top flange offset in the opposite direction, hangers 3½" and less wide have allowable load of 25% of the table load or 1335 lbs. whichever is lower, and for hangers wider than 3½", the allowable load is 30% of the table load or 1620 lbs. whichever is lower.

OPEN/CLOSED TOP FLANGE

- The top flange may be opened more or closed less than the standard 90° (*see illustration*) to a maximum of 30°, except the HW which cannot be closed. W and WI hangers must use 10d x 1½" nails for closed application. Reduce allowable loads using straight-line interpolation (*see sloped top flange*).

SADDLE HANGER

- To order, add D to model and specify S dimension (*see illustration*).
- Saddle hangers achieve catalog load listed. Saddle hangers on stud walls do not achieve catalog loads.
- Recommended S dimension is ¼" oversized for carrying members 2½" wide and less or ⅛" oversized for greater than 2½" wide.

RIDGE HANGER (not available for uplift models)

- Top flange may be sloped to a maximum of 35° to accommodate a ridge (*see illustration*). Specify angle of the slope. Reduce allowable load using straight-line interpolation. See Open/Closed example.

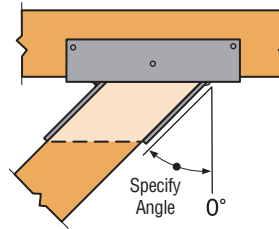

**Typical W Top View
Skewed Left Type A Hanger**
(Bevel Cut Joist Shown)

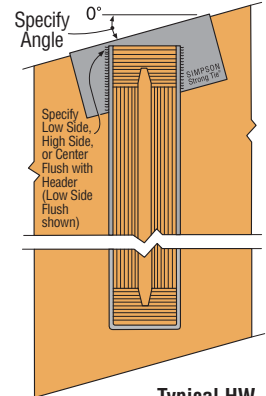

**Typical HW
Top Flange Sloped Down
Left with Low Side Flush**

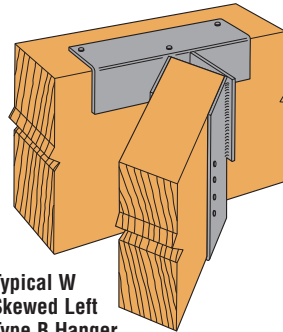

**Typical W
Skewed Left
Type B Hanger**
(Square Cut Joist Shown)

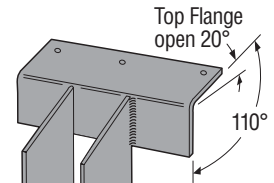

**WNP
with Open
Top Flange**

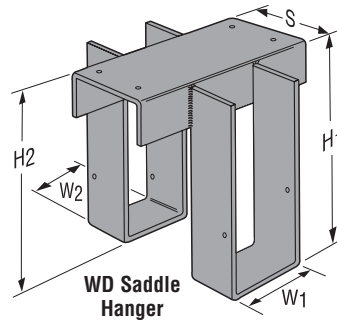

**WD Saddle
Hanger**

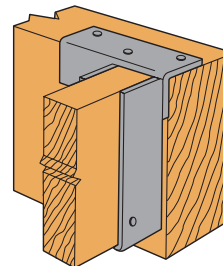

Typical W Top Flange Offset Left

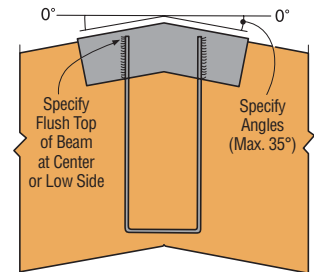

Typical W Ridge Installation

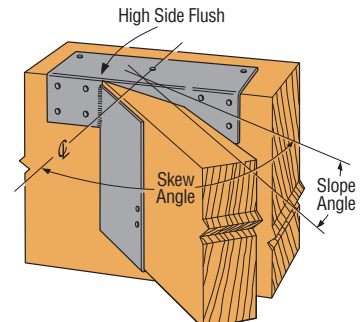
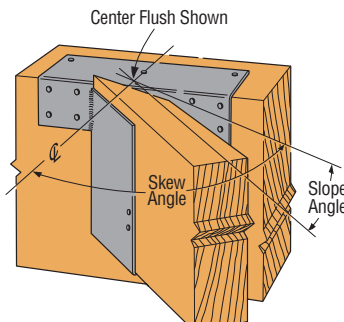
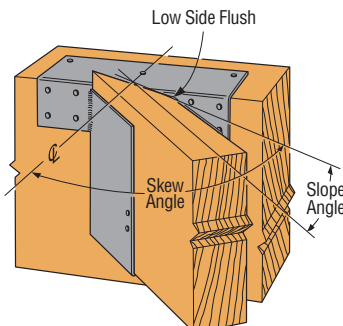

Typical HW Sloped Down, Skewed Right with Type A Hanger (Joist end must be bevel cut)
When ordering, specify Low Side Flush, Center Flush or High Side Flush

HANGER OPTIONS

LEG/MEG/EG

See Hanger Options General Notes.

SKewed SEAT — TOP FLANGE MODELS ONLY

- The LEG/MEG/EG series can be skewed up to 45°. The maximum allowable load is 10,000 lbs. for LEG and MEG, 14,250 lbs. for EG.

SLOPED SEAT — TOP FLANGE MODELS ONLY

- The LEG/MEG/EG series can be sloped up to 45°. The maximum allowable load is 9665 lbs.; see illustration.

NO SLOPED AND SKewed COMBO AVAILABLE.

OFFSET TOP FLANGE

- The LEG/MEG (only) top flange may be offset left or right for placement at the end of a header (see illustration). The maximum allowable load is 5665 lbs. (Min. H = 11" for MEG, 9" for LEG)
- No skews allowed on offset hangers.

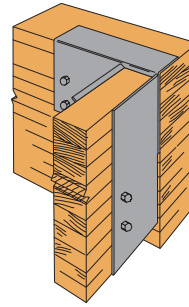

Typical LEG/MEG
Top Flange Offset Left

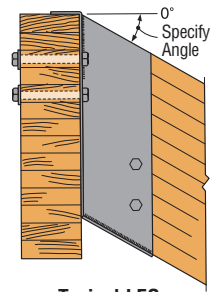

Typical LEG
Sloped Down Installation
(MEG/EG similar)

EGQ

See Hanger Options General Notes.

SKewed SEAT

- The EGQ can be skewed a maximum of 45°.
- The maximum allowable download when skewed is 16,300 lbs.
- The maximum allowable uplift when skewed is 5770 lbs.
- Joist must be bevel cut for skewed seat installation.

SLOPED SEAT

- The EGQ can be sloped up or down a maximum of 45°.
- The maximum allowable download when sloped is 15360 lbs.
- The allowable uplift when sloped is 100% of the table load.
- Sloped seat installation requires an additional 14 joist screws (supplied with the connector).

NO SLOPED AND SKewed COMBO AVAILABLE.

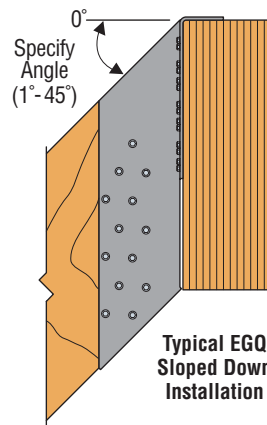

Typical EGQ
Sloped Down
Installation

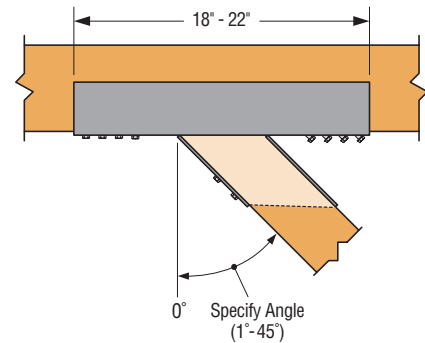

Top View EGQ
Skewed Right

HUTF/HUITF

See Hanger Options General Notes.

SLOPED AND/OR SKewed SEAT

- HUTF can be skewed to a maximum of 45° or sloped to a maximum of 45°. HUTF can be skewed and sloped down only, provided $W \geq 2\frac{3}{8}"$. Hangers with a skew greater than 15° may have all the joist nailing on the outside angle. No skew with slope up options available.
- For skews greater than 15°, uplift loads are 0.75 of the table loads.
- For sloped and skewed combinations, the allowable loads are 0.70 of the table loads.
- HU43TF may be skewed only 45° at 0.45 of table loads. No options for HU24-2TF and HU44TF.
- For sloped down only hangers, allowable load is 0.78 of the table load.

CONCEALED FLANGE

- HUTF is available with one A flange concealed at 0.85 of the catalog table load. HUTF is also available with both flanges concealed provided the W dimension is $2\frac{3}{8}"$ or greater, at 0.85 of the table load. Specify HUCTF for both flanges concealed. No skew options available.

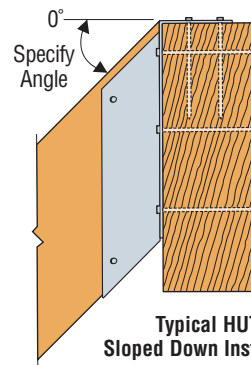

Typical HUTF
Sloped Down
Installation

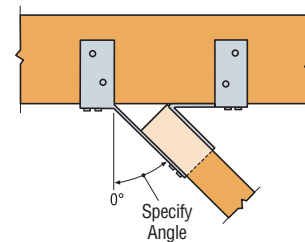

Top View HUTF Hanger
Skewed Right

HANGER OPTIONS

LGU/MGU/HGU/HHGU/LGUM/HGUM

See Hanger Options General Notes.

CONCEALED FLANGE

- LGU, MGU, HGU, HHGU and HGUM hangers are available with one flange concealed. Specify flange to conceal.
- Allowable Loads for one flange-concealed option:
 - LGU 1.00 of published load
 - MGU 0.88 of published load
 - HGU 0.75 of published load
 - HHGU 0.75 of published load
 - HGUM see table below
- **LGU with W 3/4" or less, MGU with W 4" or less and HGU with W 4 11/16" or less, flanges cannot be concealed.**

Concealed Flange – Allowable Loads with One Flange Concealed

Model No.	W (in)	H (in)	Fasteners		End of Wall				Outside corner	
			CMU/Concrete Titen HD® Anchors	Joist SDS Screws	CMU Wall DF/SP/SCL Beam		Concrete Wall DF/SP/SCL Beam		CMU/Concrete Wall DF/SP/SCL Beam	
					Uplift (160)	Download	Uplift (160)	Download	Uplift (160)	Download
HGUM	5 1/4 to 9	11 to 30	8-5/8"x5"	24-1/4"x2 1/2"	1285	5750	3150	7025	3150	7555

SKEWED

- LGU, MGU, HGU, LGUM and HGUM hangers are available skewed up to 45°.
- Apply the following reduction factors to published loads:

Reduction Factors for Skewed LGU, MGU, HGU

Model	Beam Cut	Download	Uplift
LGU	Square Cut	0.90	0.60
	Bevel Cut	0.90	0.60
MGU/HGU less than 6" wide	Square Cut	0.75	0.65
	Bevel Cut	0.80	0.65
MGU/HGU 6" and wider	Bevel Cut	0.80	0.55

- For LGUM and HGUM see table below.
- Concealed flanges are not available with skewed models.

LGUM/HGUM Allowable Loads for Skewed (L/R) Applications

Model No.	Fasteners		Allowable Loads CMU/Concrete	
	CMU/Concrete Titen HD® Anchors	Joist SDS Screws	(DFL, SP, LVL, PSL, LSL)	
			Uplift (160)	Download (100/115/125)
LGUM26-2X	4-3/8"x4"	4-1/4"x2 1/2"	565	1965
LGUM26-3X				
LGUM26-4X				
LGUM46X	6-3/8"x4"	6-1/4"x2 1/2"	1085	3080
LGUM28-2X				
LGUM28-3X				
LGUM28-4X				
LGUM48X	8-3/8"x4"	8-1/4"x2 1/2"	1605	4190
LGUM210-2X				
LGUM210-3X				
LGUM210-4X				
LGUM410X	8-5/8"x5"	8-1/4"x2 1/2"	1430	6455
HGUM5.25X				
HGUM5.50X				
HGUM7.00X				
HGUM7.25X	8-5/8"x5"	8-1/4"x2 1/2"	1440	5820
HGUM9.00X				

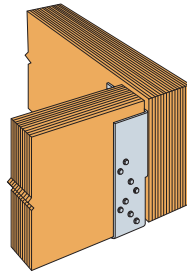

Typical MGU Installation with Right Flange Concealed

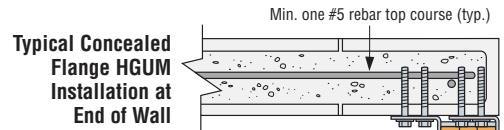

Typical Concealed Flange HGUM Installation at End of Wall

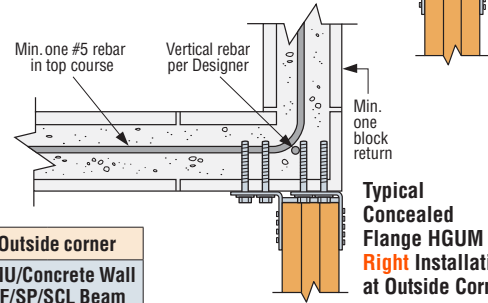

Typical Concealed Flange HGUM Right Installation at Outside Corner

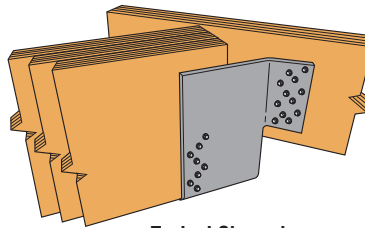

Typical Skewed MGU Installation (Skewed left shown)

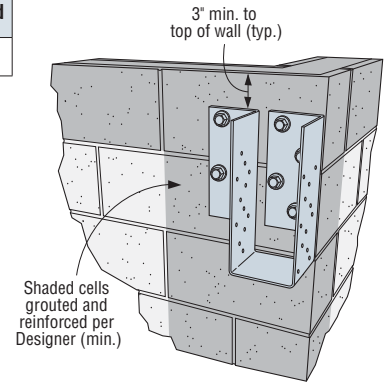

Typical Concealed Flange HGUM Installation at Outside Corner (Concealed right shown)

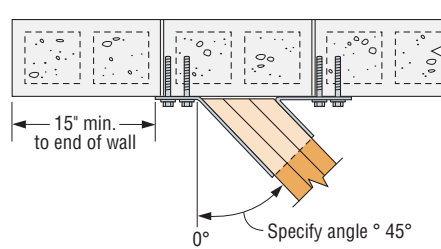

Top View HGUM Skewed Right Bevel Cut

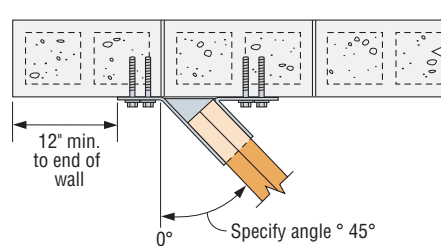

Top View LGUM Skewed Right Square Cut

MBHA

See Hanger Options General Notes.

SKEWED SEAT

- Seat can be skewed at 45° only. The maximum allowable download is 3495 lbs. and 1585 lbs. uplift for Height 7 1/4". For all other models, use the table listed download and uplift of 2390 lbs.
- Order MBHAR for skew right and MBHAL for skew left.

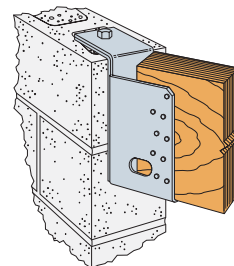

Typical MBHA Skewed Right Installation

CONTINUOUS LOAD TRANSFER PATH

This drawing shows the connection points for a continuous load transfer path from the rafters to the foundation of a two-story house.

Building with a continuous load path is an essential part of creating a structure better able to withstand the forces of mother nature.

This drawing is for illustrative purposes only and should not be considered an engineered system. Refer to the page numbers for the full range of Simpson Strong-Tie® connectors. Consult a qualified Designer to ensure that correct connector quantities and installation methods are used to achieve the full design load values.

TYPICAL ROOF/WALL CONNECTIONS
Pages 196 to 205

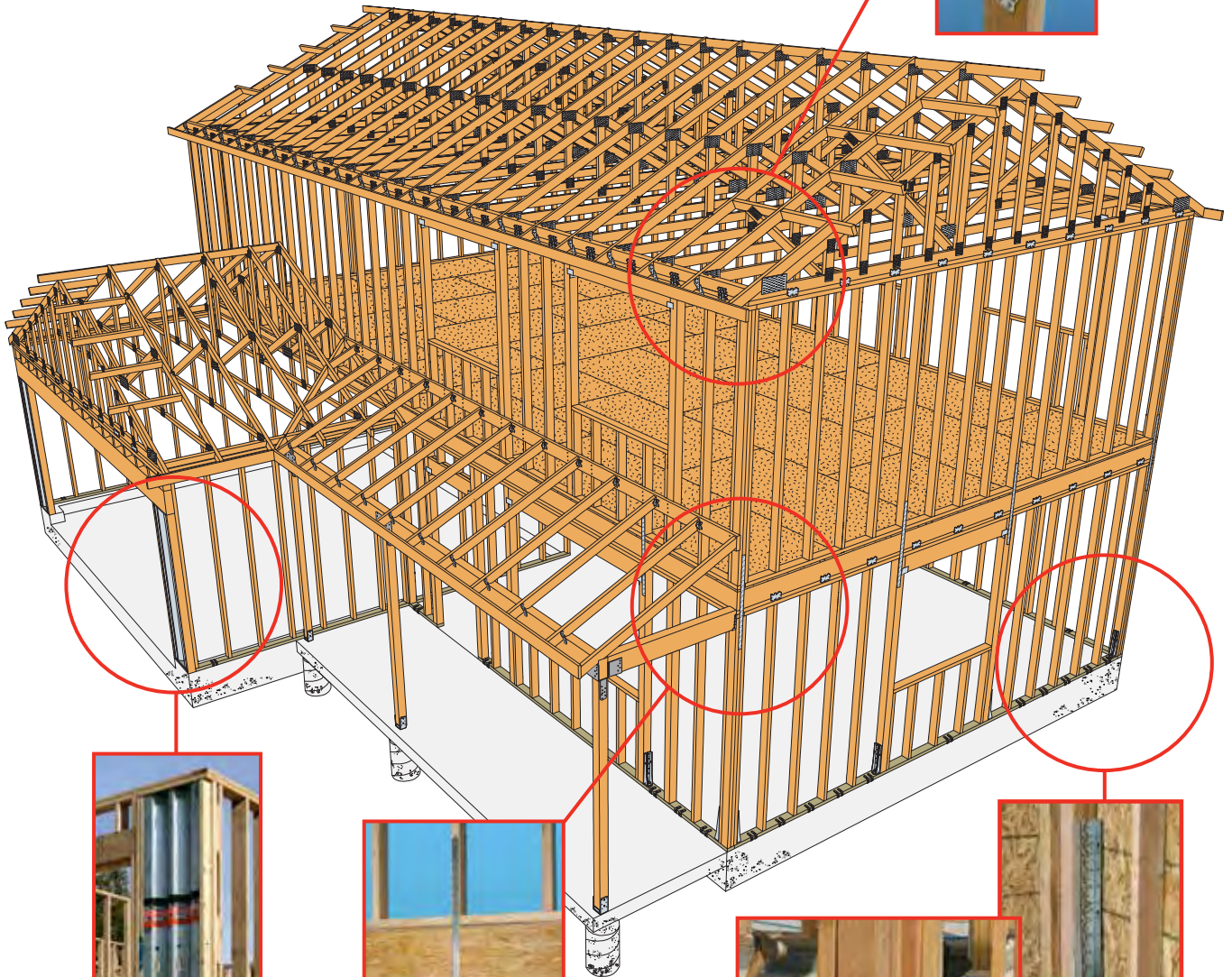
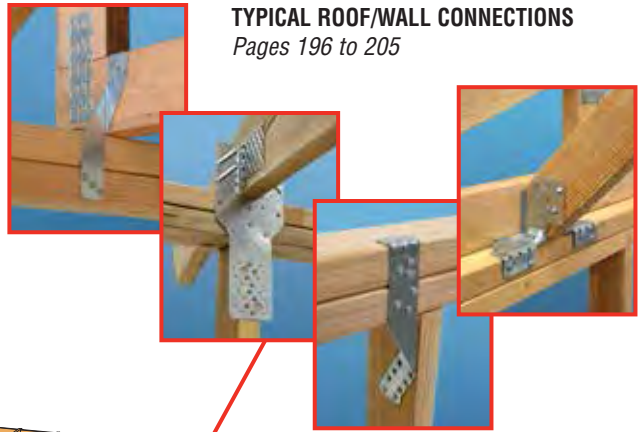

LATERAL SYSTEMS
Visit www.strongtie.com
for more information



TYPICAL FLOOR-TO-FLOOR CONNECTIONS
Pages 46 to 50, 185 to 194



TYPICAL FOUNDATION CONNECTIONS
Pages 29 to 54



POST CAPACITIES

Post Allowable Compression Loads for Douglas-Fir-Larch

Framing	Lumber		Perp to Grain, P _C ⊥	Compression Capacity Parallel to Grain, P _C (100)					Compression Capacity Parallel to Grain, P _C (160)				
	Size	Grade		Nominal Top Plate Height (ft.)					Nominal Top Plate Height (ft.)				
				8	9	10	11	12	8	9	10	11	12
4-Inch Wall	2x4	#2	3280	3170	2565	2105	1755	1485	3345	2665	2170	1795	1510
	3x4	#2	5470	5285	4275	3510	2930	2475	5570	4440	3615	2995	2520
	2-2x4	#2	6565	6340	5130	4215	3515	2970	6685	5330	4335	3590	3020
	4x4	#2	7655	7395	5985	4915	4100	3465	7800	6215	5060	4190	3525
	3-2x4	#2	9845	9510	7695	6320	5270	4455	10030	7995	6505	5390	4535
	4x6	#2	12030	11540	9360	7700	6425	5430	12215	9745	7935	6575	5535
	4x8	#2	15860	15090	12270	10105	8440	7140	16035	12805	10435	8650	7285
4x10	#2	20235	19080	15555	12835	10730	9085	20365	16285	13280	11015	9280	
6-Inch Wall	2x6	#2	5155	8970	7940	6935	6025	5235	11030	9230	7740	6535	5575
	3x6	#2	8595	14945	13235	11560	10040	8725	18385	15380	12895	10895	9290
	2-2x6	#2	10315	17935	15885	13875	12050	10470	22060	18455	15475	13075	11145
	4x6	#2	12030	20925	18530	16185	14060	12215	25735	21530	18055	15255	13005
	3-2x6	#2	15470	26905	23825	20810	18075	15705	33090	27685	23215	19610	16720
	6x6	#1	18905	25260	23500	21505	19415	17375	34255	30035	26025	22475	19450
	6x8	#1	25780	34450	32045	29320	26475	23690	46715	40955	35485	30645	26520

Post Allowable Compression Loads for Southern Pine

Framing	Lumber		Perp to Grain, P _C ⊥	Compression Capacity Parallel to Grain, P _C (100)					Compression Capacity Parallel to Grain, P _C (160)				
	Size	Grade		Nominal Top Plate Height (ft.)					Nominal Top Plate Height (ft.)				
				8	9	10	11	12	8	9	10	11	12
4-Inch Wall	2x4	#2	2965	2815	2270	1860	1550	1310	2955	2350	1910	1580	1330
	3x4	#2	4945	4690	3785	3105	2585	2180	4920	3920	3185	2635	2220
	2-2x4	#2	5935	5625	4540	3725	3100	2620	5905	4700	3820	3165	2660
	4x4	#2	6920	6565	5295	4345	3615	3055	6890	5485	4460	3690	3105
	3-2x4	#2	8900	8440	6810	5585	4650	3925	8860	7050	5735	4745	3990
	4x6	#2	10875	10260	8295	6810	5675	4790	10800	8600	6995	5795	4875
	4x8	#2	14335	13450	10890	8950	7460	6305	14195	11315	9210	7630	6420
4x10	#2	18290	17055	13835	11380	9495	8030	18055	14405	11730	9720	8180	
6-Inch Wall	2x6	#2	4660	8195	7190	6230	5385	4660	9905	8235	6875	5795	4930
	3x6	#2	7770	13655	11980	10385	8975	7765	16510	13725	11460	9655	8220
	2-2x6	#2	9325	16390	14375	12465	10765	9320	19810	16470	13755	11590	9865
	4x6	#2	10875	19120	16775	14540	12560	10875	23115	19215	16045	13520	11505
	3-2x6	#2	13985	24580	21565	18695	16150	13980	29715	24700	20630	17385	14795
	6x6	#1	17090	21495	20270	18835	17260	15655	30025	26820	23595	20610	17975
	6x8	#1	23305	29315	27640	25680	23540	21345	40940	36575	32180	28105	24515

Post Allowable Compression Loads for Spruce-Pine-Fir

Framing	Lumber		Perp to Grain, P _C ⊥	Compression Capacity Parallel to Grain, P _C (100)					Compression Capacity Parallel to Grain, P _C (160)				
	Size	Grade		Nominal Top Plate Height (ft.)					Nominal Top Plate Height (ft.)				
				8	9	10	11	12	8	9	10	11	12
4-Inch Wall	2x4	#1/#2	2230	2775	2250	1850	1540	1305	2930	2340	1905	1575	1325
	3x4	#1/#2	3720	4625	3745	3080	2570	2170	4885	3895	3175	2630	2210
	2-2x4	#1/#2	4465	5545	4495	3695	3085	2605	5865	4675	3805	3155	2655
	4x4	#1/#2	5205	6470	5245	4310	3595	3040	6840	5455	4440	3680	3095
	3-2x4	#1/#2	6695	8320	6745	5545	4625	3910	8795	7015	5710	4730	3980
	4-2x4	#1/#2	8925	11095	8990	7395	6165	5215	11730	9355	7615	6310	5310
	4x6	#1/#2	10875	13665	11075	9165	7665	6515	14195	11315	9210	7630	6420
6-Inch Wall	2x6	#1/#2	3505	7745	6885	6035	5255	4575	9600	8055	6770	5725	4885
	3x6	#1/#2	5845	12905	11475	10060	8760	7625	16000	13425	11280	9545	8145
	2-2x6	#1/#2	7015	15485	13770	12070	10515	9150	19200	16110	13540	11450	9770
	3-2x6	#1/#2	10520	23230	20660	18110	15770	13730	28795	24165	20305	17180	14660
	4-2x6	#1/#2	14025	30970	27545	24145	21025	18305	38395	32225	27075	22905	19545

Post Allowable Compression Loads for Hem-Fir

Framing	Lumber		Perp to Grain, P _C ⊥	Compression Capacity Parallel to Grain, P _C (100)					Compression Capacity Parallel to Grain, P _C (160)				
	Size	Grade		Nominal Top Plate Height (ft.)					Nominal Top Plate Height (ft.)				
				8	9	10	11	12	8	9	10	11	12
4-Inch Wall	2x4	#2	2125	2630	2115	1730	1435	1210	2745	2180	1770	1465	1230
	3x4	#2	3545	4385	3525	2880	2395	2020	4570	3630	2950	2440	2050
	2-2x4	#2	4255	5260	4230	3460	2875	2425	5485	4355	3540	2925	2460
	4x4	#2	4960	6140	4935	4035	3355	2830	6400	5085	4125	3415	2870
	3-2x4	#2	6380	7890	6340	5185	4310	3635	8230	6535	5305	4390	3690
	4-2x4	#2	8505	10525	8455	6915	5750	4850	10970	8715	7075	5855	4920
	4x6	#2	10875	13665	11075	9165	7665	6515	14195	11315	9210	7630	6420
6-Inch Wall	2x6	#2	3340	7950	6880	5905	5065	4365	9385	7735	6425	5395	4580
	3x6	#2	5570	13250	11470	9840	8440	7270	15640	12890	10710	8995	7635
	2-2x6	#2	6685	15900	13765	11810	10130	8725	18765	15470	12850	10790	9165
	3-2x6	#2	10025	23855	20645	17715	15195	13090	28150	23205	19275	16185	13745
	4-2x6	#2	13365	31805	27525	23620	20260	17455	37535	30935	25700	21585	18325

See footnotes on page 246.

POST CAPACITIES

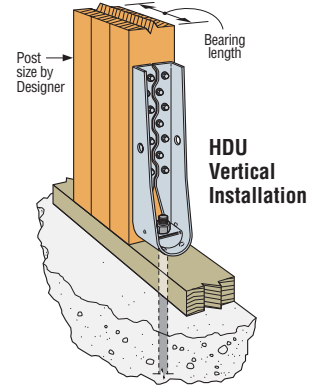
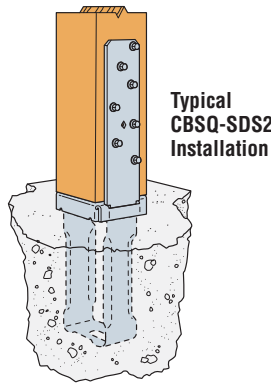
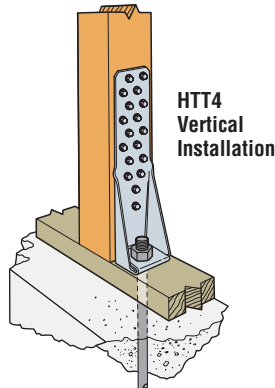
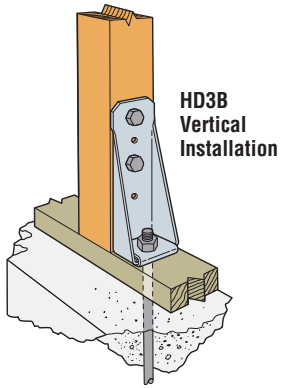

Post Tension Loads for Douglas-Fir-Larch

Framing	Lumber		Allowable Tension				
			P _t , (160)				
	Size	Grade	Bolt Diameter (in.)				
			0	1/2	5/8	7/8	1
4-Inch Wall	2x4	#2	7245	6080	5820	5305	5045
	3x4	#2	12075	10135	9705	8840	8410
	2-2x4	#2	14490	12160	11645	10610	10090
	4x4	#2	16905	14190	13585	12375	11775
	3-2x4	#2	21735	18240	17465	15915	15135
	4x6	#2	23025	19325	18500	16855	16035
	4x8	#2	28015	23510	22510	20510	19510
6-Inch Wall	2x6	#2	9865	8860	8635	8185	7960
	3x6	#2	16445	14765	14390	13640	13270
	2-2x6	#2	19735	17715	17265	16370	15920
	4x6	#2	23025	20670	20145	19100	18575
	3-2x6	#2	29600	26575	25900	24555	23885
	6x6	#1	32670	29330	28585	27100	26360
	6x8	#1	44550	39995	38980	36955	35945

Post Tension Loads for Southern Pine

Framing	Lumber		Allowable Tension				
			P _t , (160)				
	Size	Grade	Bolt Diameter (in.)				
			0	1/2	5/8	7/8	1
4-Inch Wall	2x4	#2	5670	4760	4555	4150	3950
	3x4	#2	9450	7930	7595	6920	6580
	2-2x4	#2	11340	9520	9115	8305	7900
	4x4	#2	13230	11105	10630	9685	9215
	3-2x4	#2	17010	14275	13670	12455	11845
	4x6	#2	18480	15510	14850	13530	12870
	4x8	#2	22330	18740	17945	16350	15550
6-Inch Wall	2x6	#2	7920	7110	6930	6570	6390
	3x6	#2	13200	11850	11550	10950	10650
	2-2x6	#2	15840	14220	13860	13140	12780
	4x6	#2	18480	16590	16170	15330	14910
	3-2x6	#2	23760	21330	20790	19710	19170
	6x6	#1	43560	39105	38115	36135	35145
	6x8	#1	59400	53325	51975	49275	47925

Post Tension Loads for Spruce-Pine-Fir

Framing	Lumber		Allowable Tension				
			P _t , (160)				
	Size	Grade	Bolt Diameter (in.)				
			0	1/2	5/8	7/8	1
4-Inch Wall	2x4	#1/#2	5670	4760	4555	4150	3950
	3x4	#1/#2	9450	7930	7595	6920	6580
	2-2x4	#1/#2	11340	9520	9115	8305	7900
	4x4	#1/#2	13230	11105	10630	9685	9215
	3-2x4	#1/#2	17010	14275	13670	12455	11845
6-Inch Wall	2x6	#1/#2	7720	6930	6755	6405	6230
	3x6	#1/#2	12870	11555	11260	10675	10385
	2-2x6	#1/#2	15445	13865	13515	12810	12460
	3-2x6	#1/#2	23165	20795	20270	19215	18690
	4-2x6	#1/#2	28315	25420	24775	23490	22845

Post Tension Loads for Hem-Fir

Framing	Lumber		Allowable Tension				
			P _t , (160)				
	Size	Grade	Bolt Diameter (in.)				
			0	1/2	5/8	7/8	1
4-Inch Wall	2x4	#2	7245	6080	5820	5305	5045
	3x4	#2	12075	10135	9705	8840	8410
	2-2x4	#2	14490	12160	11645	10610	10090
	4x4	#2	16905	14190	13585	12375	11775
	3-2x4	#2	21735	18240	17465	15915	15135
6-Inch Wall	2x6	#2	9865	8860	8635	8185	7960
	3x6	#2	16445	14765	14390	13640	13270
	2-2x6	#2	19735	17715	17265	16370	15920
	3-2x6	#2	29600	26575	25900	24555	23885
	4-2x6	#2	39470	35430	34535	32740	31845

- The allowable (ASD) capacities are based on the 2012 *National Design Specification for Wood Construction* (NDS) including the **March 2013 Addendum**, for lumber with a moisture content of 19% or less.
- Post heights are based on standard precut stud heights and associated top plate heights. For Douglas Fir, wall height is nominal height plus 3/4" (*California stud height*). For all other species, wall height is nominal height plus 1 1/2". Effective post lengths, l_e, are the actual wall height s minus the thickness of 3-2x plates (4 1/2").
- Shaded values are limited by the Perpendicular to Grain bearing capacity, P_{C⊥}, when posts bear on wood sill plates. Where posts and sill plates are different species, Designer shall limit allowable load to the lower of the post capacity or the perpendicular to grain capacity for each species used.
- Perpendicular to grain allowable loads do not include the NDS Bearing Area Factor, C_b. For posts whose bearing area is not closer than 3" from the end of a sill plate, the P_{C⊥} values may be multiplied by C_b.

T (in.)	1.5	2.5	3	3.5	4.5	5.5	≥6
C _b	1.25	1.15	1.13	1.11	1.08	1.07	1

T = Bearing Length (*post thickness*)
C_b = Bearing Area Factor per NDS 3.10.4

- Tension loads are based on net section assuming hole size equal to bolt diameter plus 1/16". Tension loads have been increased for wind or seismic loading with no further increase allowed. Reduce where other loads govern.
- Values do not consider combined axial and out-of-plane bending.
- Bolt diameter "None" indicates full cross section.



Every day we work hard to earn your business, blending the talents of our people with the quality of our products and services to exceed your expectations. This is our pledge to you.

Home Office

5956 W. Las Positas Boulevard
Pleasanton, CA 94588
Tel: 925/560-9000 • Fax: 925/847-1603

Northwest USA

5151 S. Airport Way
Stockton, CA 95206
Tel: 209/234-7775 • Fax: 209/234-3868

Southwest USA

12246 Holly Street
Riverside, CA 92509
Tel: 714/871-8373 • Fax: 951/369-2889

Northeast USA

2600 International Street
Columbus, OH 43228
Tel: 614/876-8060 • Fax: 614/876-0636

Southeast USA

2221 Country Lane
McKinney, TX 75069
Tel: 972/542-0326 • Fax: 972/542-5379

Kent Specials Factory

22023 68th Avenue S.
Kent, WA 98032
Toll Free: 877/564-2041

Eagan Warehouse & Specials Factory

3711 Kennebec Drive, Suite 700
Eagan, Minnesota 55122
Tel: 651/681-2061 • Fax: 651/681-2046

Eastern Canada

5 Kenview Boulevard
Brampton, ON L6T 5G5
Tel: 905/458-5538 • Fax: 905/458-7274

Western Canada

11476 Kingston Street
Maple Ridge, B.C. V2X 0Y5
Tel: 604/465-0296 • Fax: 604/465-0297

Distribution Centers

Chandler, AZ; Enfield, CT;
High Point, NC; Houston, TX;
Jacksonville, FL; Kansas City, KS;
Jessup, MD;

INTERNATIONAL FACILITIES

Please visit our website for address and contact information for our European facilities.

*This catalog reflects changes in the allowable loads and configurations of some Simpson Strong-Tie Company Inc. products. **This catalog is effective until December 31, 2016**, and supersedes all information in all earlier publications, including catalogs, brochures, fliers, technical bulletins, etc. Use this edition as a current printed reference. Information on allowable loads and configurations is updated annually.*

***We post our catalogs on www.strongtie.com. Please visit our site and sign up for any information updates.** Allowable loads in this catalog are for the described specific applications of properly installed products. Product modifications, improper loading or installation procedures, or deviations from recommended applications will affect connector allowable load-carrying capacities.*

Can You
Define
Genuine?
We Can.



We believe in:

- Doing what's right
- Tackling problems differently
- Sharing our knowledge
- Going the extra mile
- Having the right solutions at the right time

GENUINE
Simpson Strong-Tie® Connectors

