



Standard Specification for Manually Operated Fueling Hose Reels¹

This standard is issued under the fixed designation F 1347; the number immediately following the designation indicates the year of original adoption or, in the case of revision, the year of last revision. A number in parentheses indicates the year of last reapproval. A superscript epsilon (ϵ) indicates an editorial change since the last revision or reapproval.

1. Scope

1.1 This specification covers manually operated fueling hose reels for use with collapsible and noncollapsible hose.

1.2 The values stated in inch-pound units are to be regarded as standard. The SI units given in parentheses are for information only.

1.3 The following precautionary caveat pertains only to the test methods portion, Section 12 of this specification: *This standard does not purport to address all of the safety concerns, if any, associated with its use. It is the responsibility of the user of this standard to establish appropriate safety and health practices and determine the applicability of regulatory limitations prior to use.*

2. Referenced Documents

2.1 ASTM Standards:

B 148 Specification for Aluminum-Bronze Sand Castings²

D 3006 Specification for Polyethylene Plastic Pressure-Sensitive Electrical Insulating Tape³

D 3951 Practice for Commercial Packaging⁴

2.2 Military Specifications:⁵

MIL-S-901 Shock Test, H.I. (High-Impact); Shipboard Machinery, Equipment and Systems, Requirements for
MIL-T-16366 Terminals, Electric Lug and Conductor Splices, Crimp Style

MIL-H-17902 Hose, End Fittings and Hose Assemblies, Synthetic Rubber, Aircraft Fuels

MIL-F-20042 Flanges, Pipe and Bulkhead, Bronze (Silver Brazing)

MIL-P-24441 Epoxy-Polyamide Primer

2.3 Military Standard:⁵

MIL-STD-130 Identification Marking of U.S. Military Property

3. Classification

3.1 Fueling hose reels shall be of one of the following types as specified:

3.1.1 *Type 1*—For 150 ft (46 m) of collapsible 2½-in. (65-mm) hose.

3.1.2 *Type 2*—For 150 ft (46 m) of noncollapsible 1½-in. (38-mm) hose or 100 ft (30 m) of noncollapsible 2-in. (50-mm) hose.

3.1.3 *Type 3*—For 150 ft (46 m) of noncollapsible 1½-in. (38-mm) hose or for 150 ft (46 m) of collapsible 2½-in. (65-mm) hose.

3.1.4 *Type 4*—Capacity as specified by purchaser.

4. Ordering Information

4.1 Orders for material under this specification shall include the following information:

4.1.1 Title, number, and year of issue of this specification,

4.1.2 Type of hose reel including hose size and type (see 3.1), (length of hose for Type 4),

4.1.3 Whether right- or left-hand reels are required (see 6.5),

4.1.4 Flange inlet thickness and bolt hole dimensions (see 6.7),

4.1.5 Drawings required (see 9.1),

4.1.6 The number of samples to be inspected and tested (see 11.2),

4.1.7 Certification, if required (see 15.1),

4.1.8 Test report, if required (see 15.1), and

4.1.9 Applicability of supplementary requirements.

5. Materials and Manufacture

5.1 Except as otherwise specified herein, the hose reels shall be constructed of aluminum, aluminum bronze, or other suitable nonsparking materials. All fittings conveying aromatic fuels through the hose reel shall be made of aluminum bronze in accordance with Specification B 148, copper alloy UNS No. C95300. To prevent deterioration in sea atmosphere, aluminum parts should not contact brass or bronze; however, where such aluminum parts come in contact with brass or bronze, they shall be protected by adhesive-backed insulating tape, Specification D 3006. All aluminum parts shall be given a coat of epoxy-polyamide primer.

6. Construction

6.1 *Reel and Drum Assembly*—The hose reel shall be of a durable, rigid construction, as light in weight and compact as practicable. The drum assembly (drum, reel sides, and its reinforcements) shall withstand the hose pull without distortion or collapse and shall be capable of withstanding some sideways hose pull without undue distortions. The construction of the

¹ This specification is under the jurisdiction of ASTM Committee F-25 on Ships and Marine Technology and is the direct responsibility of Subcommittee F25.07 on General Requirements.

Current edition approved July 15, 1991. Published September 1991.

² *Annual Book of ASTM Standards*, Vol 02.01.

³ *Annual Book of ASTM Standards*, Vol 10.02.

⁴ *Annual Book of ASTM Standards*, Vol 15.09.

⁵ Available from Standardization Documents Order Desk, Building 4D, 700 Robbins Ave., Philadelphia, PA 19111-5094, Attn: NPODS.

completed drum assembly shall be such that disassembly can be readily accomplished with standard tools. When bolted down to a true flat surface, the shaft and rotating seal centerlines shall be in true alignment and the drum assembly shall turn without binding under a rim pull not to exceed 7 lb (198 kg) with the reel unpressurized. Both ends of the drum shaft shall be supported on ball or roller bearings that shall have provision for easy lubrication. Reels shall be designed so that all bearings, and other corrodible parts, are adequately protected from the weather. Provision shall be made for lubrication of working parts such as bearings or other mating surfaces, and all such parts shall be lubricated before delivery with a lubricant soluble in aromatic fuels. Bearing seals shall be such that the pressure caused by forced lubrication will not bind the shaft.

6.2 *Reel Drum*—The reel drum may have either smoothly formed flat sides or suitable spoke ribs, so formed as not to damage the hose. The rims of the drum shall provide a good grip for hand rewind.

6.3 *Holding Brake*—Reels shall be provided with a holding brake to lock the reel in any position.

6.4 *Nozzle Clamp*—The reel shall be fitted with a device for clamping the hose nozzle securely to the reel to prevent unwinding of the hose and damage to the nozzle.

6.5 *Reel Hub Discharge*—The reel hub discharge shall be angled to provide a smooth tangential contact of the hose with the reel drum as shown on Fig. 1 and Fig. 2, so that the hose will not kink at the discharge connection. The hub discharge

fitting and adapter shall be in accordance with Fig. 2 and Fig. 3 for Types 1, 2, and 3, respectively. Reels shall be right- or left-hand operation and top or bottom wind, as specified. A right-hand, top-wind reel is defined as one that, when looking into the flanged adapter on the discharge fitting when it is at the top of the drum, has its inlet connection on the right-hand side. (Note that a top-wind, right-hand reel and a bottom-wind, left-hand reel are identical.) It shall be possible by turning the discharge fitting around, or by other simple means, to enable the hose to unreel from the bottom of the reel drum to either side of the reel (that is, to make the reel either right hand or left hand) without rotating the reel drum.

6.6 *Aromatic Fuels Tight Rotating Joint*—The reel shall have an aromatic fuels tight rotating joint between reel inlet connection and the rotating hub on the reel drum. The rotating joint shall not bind under loading (shall be supported to prevent a bending load being applied), shall have provision for lubrication of moving parts, and shall be capable of easy disassembly for maintenance purposes. The rotating joint shall be tight under the pressure specified in 7.1.

6.7 *Inlet Connection*—The reel inlet connection shall be flanged, the flange being part of the rotating swivel joint. The flange thickness and bolt hole drilling shall be as specified in the contract or purchase order.

7. Performance Requirements

7.1 *Fluid Handling*—Reels shall be capable of passing 300 gal/min (0.0189 m³/s) of aviation fuel at a pressure of 150 psi

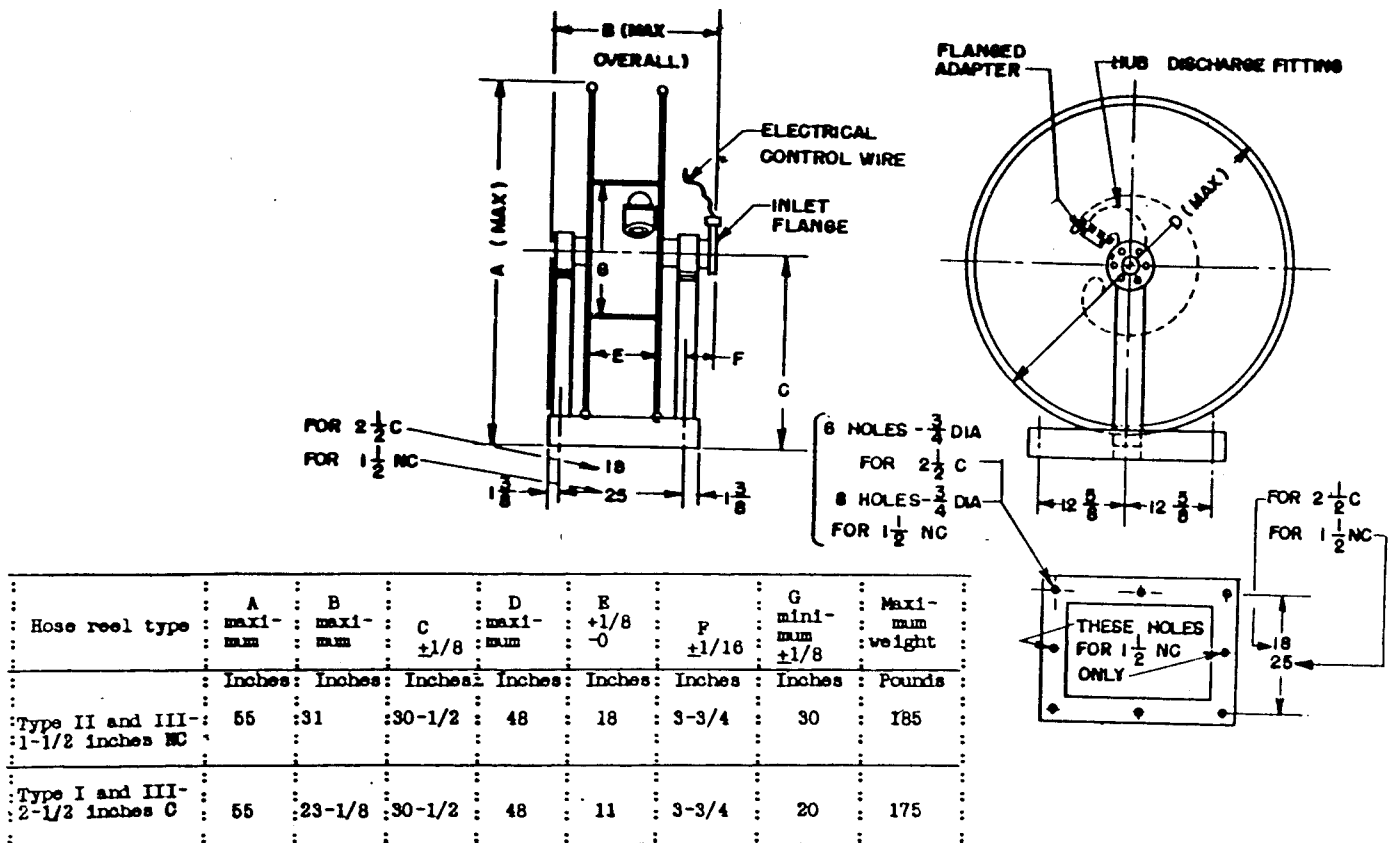

FIG. 1 Hose Reel Dimensions

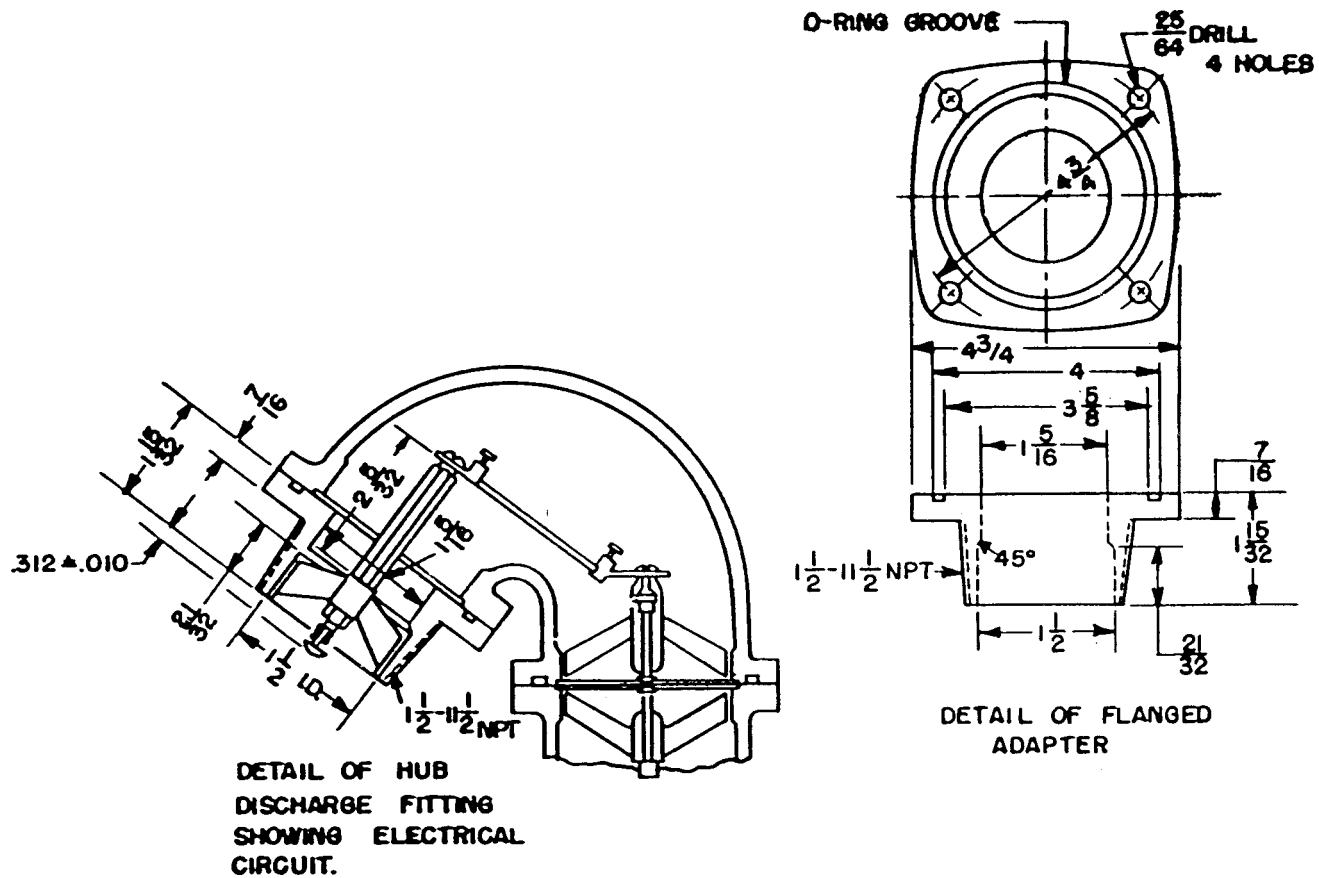

FIG. 3 Discharge Fitting and Adapter Details for Type 2 and 3, 1 1/2-in. (38-mm) Noncollapsible Reels

TABLE 1 Sampling for Quality Conformance

Lot Size Number of Units	Sample Size Number of Units	Defective Units	
		Acceptance Number	Rejection Number
1	1	0	1
2 to 8	2	0	1
9 to 15	3	0	1
16 to 25	5	0	1
26 to 50	8	0	1
51 to 90	13	0	1
91 to 150	20	0	1
151 to 280	32	1	2
281 to 500	50	2	3
501 to 1200	80	3	4

14. Rejection

14.1 *Defects*—Any defective reels in the sample shall not be offered for delivery. If the number of defective reels in any sample exceeds the acceptance number (see Table 1), this shall be cause for rejection of the entire lot.

14.2 *Leakage*—The reel shall show no leakage or any other signs of weakness after the performance of the tests specified in 12.1 and 12.2.

15. Certification

15.1 When specified in the purchase order or contract, the purchaser shall be furnished certification that samples repre-

senting each lot have been either tested or inspected as required by this specification and the requirements have been met. When specified in the purchase order or contract, a report of the test results shall be furnished.

16. Product Marking

16.1 Each hose reel shall be marked with this ASTM standard number, type of hose reel, reel hose capacity, type of hose, and size of hose.

17. Packaging and Package Marking

17.1 Packaging and package marking shall be in accordance with Practice D 3951.

18. Quality Assurance Provisions

18.1 *Responsibility for Inspection*—The supplier is responsible for the performance of all test and inspection requirements as specified herein. The supplier may use his own facilities or a commercial laboratory. The purchaser reserves the right to perform any of the inspections or tests set forth in the specification where such tests or inspections are deemed necessary to ensure supplies and services conform to prescribed requirements.

19. Keywords

19.1 fueling hose reel; hose reel; reel

SUPPLEMENTARY REQUIREMENTS

The following supplementary requirements are applicable to Department of Defense procurements and shall apply only when specified by the purchaser in the contract or purchase order:

S1. Referenced Documents

S1.1 *Military Specifications*—MIL-S-901, MIL-T-16366, MIL-H-17902, MIL-F-20042, and MIL-P-24441.

S1.2 *Military Standard*—MIL-STD-130.

S2. Construction

S2.1 *Discharge Fitting*—Unless otherwise specified in the contract or purchase order, the discharge fitting shall have an electrical contact at the center to bear against a similar contact button in the hose. From this contact on the discharge fitting, there shall be a continuous electrical path through the center of the hose reel to a terminal on the stationary part of the reel at the inlet connection (see Fig. 1 and Fig. 2). The electrical circuit through the reel shall be electrically insulated from the reel.

S2.2 *Electrical Connections*—The contact spider shown (see Fig. 2 and Fig. 3) shall be molded nylon, and the assembly shall be in accordance with requirements of MIL-H-17902. The stationary terminal shall be in accordance with MIL-T-16366. Electrical contact button on the discharge fitting shall be as shown on Fig. 2 and Fig. 3.

S2.3 *Hose*—The fueling hose to be used with these reels will be in accordance with MIL-H-17902.

S2.4 *Inlet Connection*—Unless otherwise specified in the contract or purchase order, the flange thickness and bolt hole drilling shall be in accordance with Class 250 of MIL-F-20042. The bolt holes shall straddle the vertical centerline of the flange.

S2.5 *Primer*—All steel and aluminum parts shall be given a coat of epoxy-polyamide primer, see MIL-P-24441.

S3. Shock Tests

S3.1 *Shock Tests*—The high impact (HI) shock tests shall be Grade A, Class 1, Type A tests in accordance with MIL-S-901. The reel shall be completely assembled (including hose) and shall be mounted on the shock machine in a manner simulating a typical shipboard installation. The number of blows shall be as specified in MIL-S-901.

S3.2 *Examination After Shock Tests*—Upon completion of the shock test, the equipment shall be carefully examined to

determine the extent of any damage to the mechanical components. Examination of the reels shall determine the following:
S3.2.1 The hose shall be unreeled completely and then rolled back on the reel at least five times. Any undue noise or difficulty in operation shall be investigated and the cause determined.

S3.2.2 Any unbalance shall be measured and shall not exceed twice the amplitude obtained before shock.

S3.2.3 A conductivity check shall be made to ensure that the electrical circuit through the reel is intact.

S3.2.4 The fluid-handling section of the reel (between inlet flange and discharge connection) shall be given a hydrostatic test to 225 psi (1.55 MPa) for strength and porosity and a kerosene or test fluid (solvent) test to 60 psi (413 kPa) and 120 psi (827 kPa) for tightness without showing any signs of leakage or other weakness.

S3.2.5 The reels shall be disassembled following the examination after shock tests specified and examined thoroughly for damage. The effects of the shock tests and subsequent check tests on the structure shall be carefully observed and recorded.

S3.3 *Failure to Pass Shock Tests*—The hose reel shall be considered to have failed to pass the shock tests in the event of the following:

S3.3.1 Breakage of any parts including mounting bolts.

S3.3.2 Appreciable distortion or dislocation of any parts, including mounting feet, bearings.

S3.2.3 Excessive unbalance determined as specified in S3.2.

S3.2.4 Failure to pass the hydrostatic or electrical conductivity tests.

S4. Product Marking

S4.1 Reels shall be marked in accordance with MIL-STD-130. The size of the hose to be used shall be stamped on each reel.

S5. Sampling

S5.1 In addition to the sampling requirements of the basic specification, Table 1 applies for number of samples and rejection level. If the number of defective reels in any sample exceeds the acceptance number, the lots shall be rejected.

The American Society for Testing and Materials takes no position respecting the validity of any patent rights asserted in connection with any item mentioned in this standard. Users of this standard are expressly advised that determination of the validity of any such patent rights, and the risk of infringement of such rights, are entirely their own responsibility.

This standard is subject to revision at any time by the responsible technical committee and must be reviewed every five years and if not revised, either reapproved or withdrawn. Your comments are invited either for revision of this standard or for additional standards and should be addressed to ASTM Headquarters. Your comments will receive careful consideration at a meeting of the responsible technical committee, which you may attend. If you feel that your comments have not received a fair hearing you should make your views known to the ASTM Committee on Standards, at the address shown below.

This standard is copyrighted by ASTM, 100 Barr Harbor Drive, PO Box C700, West Conshohocken, PA 19428-2959, United States. Individual reprints (single or multiple copies) of this standard may be obtained by contacting ASTM at the above address or at 610-832-9585 (phone), 610-832-9555 (fax), or service@astm.org (e-mail); or through the ASTM website (www.astm.org).