



Standard Guide for Construction of a Sounding Tube and Striker Plate for Tank Sounding¹

This standard is issued under the fixed designation F 1386; the number immediately following the designation indicates the year of original adoption or, in the case of revision, the year of last revision. A number in parentheses indicates the year of last reapproval. A superscript epsilon (ε) indicates an editorial change since the last revision or reapproval.

1. Scope

1.1 This guide provides design and construction criteria for striker plates and sounding tubes, excluding deck penetrations and caps, for use with sounding rods or tapes in freshwater, saltwater, and oil tanks.

1.2 The values stated in inch-pound units are to be regarded as the standard. The SI units given in parentheses are for information only.

1.3 *This standard does not purport to address all of the safety concerns, if any, associated with its use. It is the responsibility of the user of this standard to establish appropriate safety and health practices and determine the applicability of regulatory limitations prior to use.*

2. Referenced Documents

2.1 ASTM Standards:

- A 36/A 36M Specification for Structural Steel²
- A 53/A 53M Specification for Pipe, Steel, Black and Hot-Dipped, Zinc-Coated, Welded and Seamless³
- F 722 Specification for Welded Joints for Shipboard Piping Systems⁴
- F 1155 Practice for Selection and Application of Piping System Materials⁴

2.2 ANSI Standards:

- B16.5 Pipe Flanges and Flange Fittings⁵
- B16.9 Factory Made Wrought Steel Butt Welding Fittings⁵
- B16.11 Forged Steel, Socket Welding and Threaded Fittings⁵
- B16.28 Wrought Steel, Butt Welding, Short Radius Elbows and Return⁵
- B31.1 Power Piping⁵

2.3 ABS Standard:

American Bureau of Shipping Rules for Building and Classing Steel Vessels⁶

2.4 AWS Standard:

AWS D1.1 Structural Welding Code⁷

3. Terminology

3.1 Definitions of Terms Specific to This Standard:

3.1.1 *external sounding tube*—a sounding tube located outside the boundaries of the tank being sounded.

3.1.2 *internal sounding tube*—a sounding tube located inside the tank being sounded.

3.1.3 *sounding*—measurement by sounding; a place or part of a body of liquid where a hand sounding line will reach bottom.

4. Classification

4.1 *Type I*—Internal sounding tube, with separate striker plate.

4.2 *Type II*—Internal sounding tube, with attached striker plate.

4.3 *Type III*—Internal sounding tube, with angle striker plate.

4.4 *Type IV*—External sounding tube.

5. Significance and Use

5.1 Sounding tubes may be fabricated from 1½ NPS or larger. Only when otherwise specified, Schedule 40 components, manufactured from the list of material indicated in Practice F 1155 and Specification A 53/A 53M, Grade S or Grade ERW. In addition, sounding tubes may be fabricated in stainless steel for stainless steel tanks.

5.1.1 Sounding tubes passing through or terminating in fuel tanks, potable water tanks, or clean salt water ballast tanks should be constructed of 70-30 copper nickel, but other suitable material is acceptable.

5.2 Striker plates shall be fabricated in accordance with Specification A 36/A 36M.

¹ This guide is under the jurisdiction of ASTM Committee F25 on Ships and Marine Technology and is the direct responsibility of Subcommittee F25.11 on Machinery and Piping Systems.

Current edition approved March 15, 1992. Published December 1992.

² *Annual Book of ASTM Standards*, Vol 01.04.

³ *Annual Book of ASTM Standards*, Vol 01.01.

⁴ *Annual Book of ASTM Standards*, Vol 01.07.

⁵ Available from American National Standards Institute (ANSI), 25 W. 43rd St., 4th Floor, New York, NY 10036.

⁶ Available from American Bureau of Shipping (ABS), ABS Plaza, 16855 Northchase Dr., Houston, TX 77060.

⁷ Available from American Welding Society, 550 N.W. Lajuene Rd., Miami, FL 33125.

5.3 The fittings shall be designed in accordance with ANSI B16.5, B16.9, B16.28, or B16.11 as applicable (See Table 21 in Practice F 1155), and the installation shall be in accordance with ANSI B31.1 as modified by Specification F 722. These standards cover the fitting tolerances.

5.4 Some cargo may preclude the use of materials specified in this guide. However, configuration examples are applicable for all applications.

5.5 When a sounding tube is combined with the air escape either three 1 1/4-in. (approximately 30-mm) diameter holes approximately 12 in. (305 mm) from the tank top equally spaced or six 1/2-in. (approximately 15-mm) diameter holes approximately 6 in. (150 mm) from the tank top equally spaced can be used for perforations. See Fig. 2.

5.6 Figs. 1-4 are guidance details.

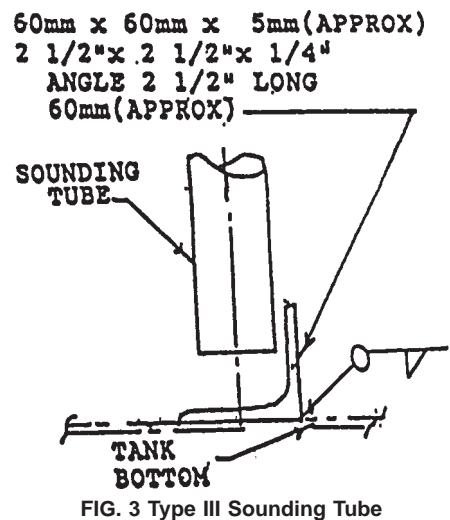
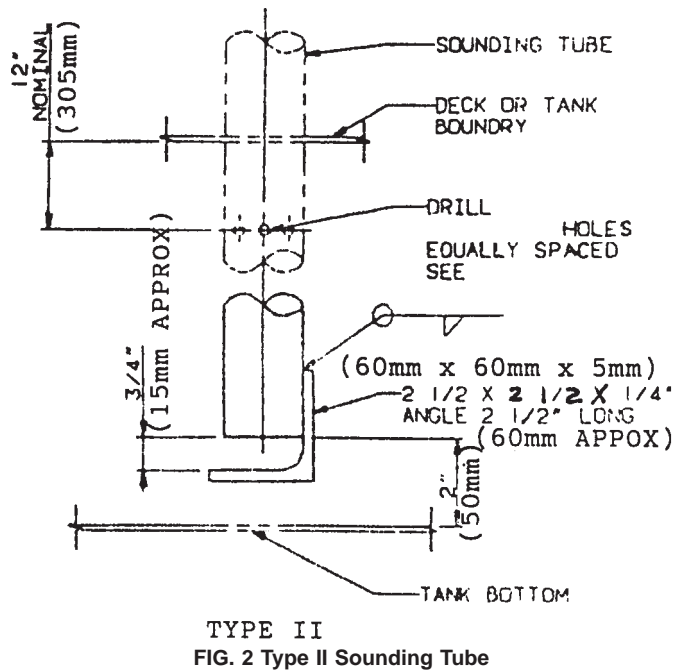
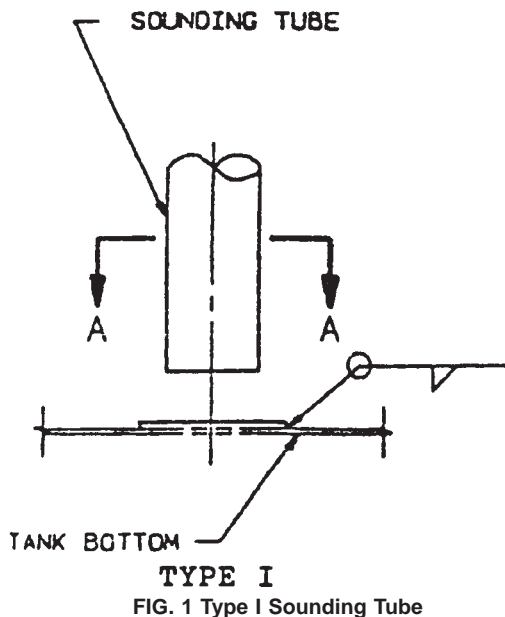
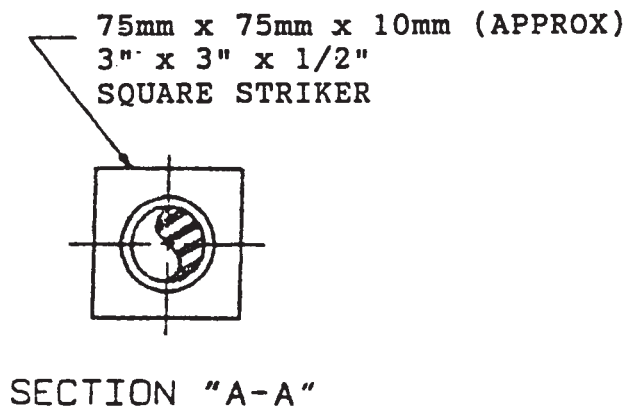

6. Installation of Sounding Tubes

6.1 Locate sounding tubes as close as possible to the lowest part of the tank.

6.2 Type I, II, and III sounding tubes, excluding oil products, shall be perforated as shown in Fig. 1, Fig. 2, and Fig. 3 respectively, for ventilation.

6.2.1 Type IV sounding tubes are only allowed where the tank cannot be penetrated from the top because of an unavoidable situation, such as a prohibitive location (see Fig. 4).

6.3 Slope and curvature shall be kept to a minimum, and under no circumstances shall the slope be permitted to exceed 45° from the vertical. Radius of curvatures up to a minimum of 10 ft (approximately 3 m) will be permitted where unavoidable.

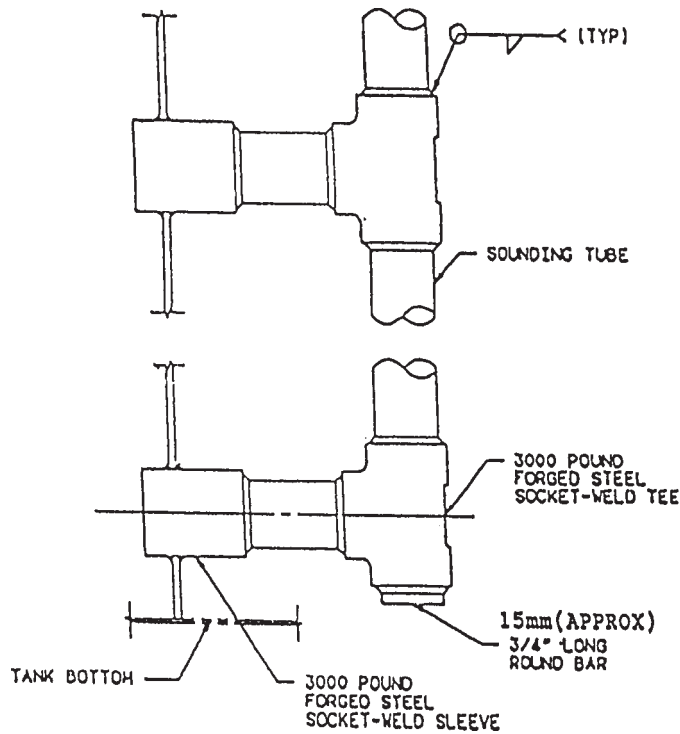

FIG. 4 Type IV Sounding Tube

6.4 Tubes may be provided with flanged take down connections, approximately 18 in. (455 mm) from the tank bottom.

6.4.1 Tubes shall be terminated close enough to tank bottoms to prevent hangup of a sounding device or a thief sampler when they are being withdrawn from a tank.

6.4.2 The inside edges of sounding tube shall be smoothed to prevent hanging up of a sounding device or thief sampler when they are being withdrawn from the tank.

6.5 Tubes shall be adequately supported to withstand both static and dynamic loads.

6.6 Welding shall be in accordance with American Bureau of Shipping Rules for Building and Classing Steel Vessels or AWS D1.1.

SUPPLEMENTARY REQUIREMENTS

S1.1 To ensure the fluid in the sounding tube is representative of the fluid in the tank when taking fuel samples, 1/2-in. (approximately 15-mm) diameter holes, 6 in. (150 mm) apart

are drilled in the sounding tubes throughout its length in the tank it serves.

ASTM International takes no position respecting the validity of any patent rights asserted in connection with any item mentioned in this standard. Users of this standard are expressly advised that determination of the validity of any such patent rights, and the risk of infringement of such rights, are entirely their own responsibility.

This standard is subject to revision at any time by the responsible technical committee and must be reviewed every five years and if not revised, either reapproved or withdrawn. Your comments are invited either for revision of this standard or for additional standards and should be addressed to ASTM International Headquarters. Your comments will receive careful consideration at a meeting of the responsible technical committee, which you may attend. If you feel that your comments have not received a fair hearing you should make your views known to the ASTM Committee on Standards, at the address shown below.

This standard is copyrighted by ASTM International, 100 Barr Harbor Drive, PO Box C700, West Conshohocken, PA 19428-2959, United States. Individual reprints (single or multiple copies) of this standard may be obtained by contacting ASTM at the above address or at 610-832-9585 (phone), 610-832-9555 (fax), or service@astm.org (e-mail); or through the ASTM website (www.astm.org).