



Standard Guide for Weight Control Technical Requirements for Surface Ships¹

This standard is issued under the fixed designation F 1808; the number immediately following the designation indicates the year of original adoption or, in the case of revision, the year of last revision. A number in parentheses indicates the year of last reapproval. A superscript epsilon (ϵ) indicates an editorial change since the last revision or reapproval.

1. Scope

1.1 This guide provides recommended weight control technical requirements for surface ships and discusses different types of weight estimates, reports, and weight control procedures. It contains a weight classification that will assist in achieving uniformity by standardizing the weight-reporting system.

1.2 This guide is applicable to ships designed and constructed in inch-pound units of measurement and to ships designed and constructed in SI units of measurement. Whenever inch-pound units are shown or referred to in the text, or in example formats included in this guide, it is to be understood that corresponding SI units may be substituted if applicable to a ship designed and constructed in SI units, provided that whichever system is used, it is consistently used in all weight control reporting documentation for the ship.

2. Referenced Documents

2.1 ASTM Standards:

F 1321 Guide for Conducting a Stability Test (Lightweight Survey and Inclining Experiment) to Determine the Light Ship Displacement and Centers of Gravity of a Vessel²

F 1332 Practice for Use of SI (Metric) Units in Maritime Applications (Committee F-25 Supplement to E 380)²

3. Terminology

3.1 Definitions:

3.1.1 *agreed weight and center of gravity estimate, n*—an estimate of light ship weight and centers of gravity data, mutually agreed upon between the owner and the shipbuilder shortly after award of the shipbuilding contract, based on the ship design information, for example, specifications, drawings, and so forth, available at the time of award.

3.1.2 *as-built weight and center of gravity estimate, n*—a detailed final estimate of light ship weight and centers of gravity data, adjusted for inclining experiment results, reflecting the as-built ship including the net effect of contract modifications.

3.1.3 *center of gravity, n*—the point through which the resultant of all gravitational forces on a ship or a component

passes. The location, a balance point, at which the entire weight of a ship may be considered to be concentrated.

3.1.4 *deadweight, n*—the total carrying capacity of a ship including weight of cargo, fuel, lubricating oil, fresh water in tanks, stores, passengers and baggage, and crew and their effects.

3.1.5 *inclining experiment, n*—a procedure performed on a completed, or almost completed, ship to establish experimentally the light ship values of the displacement and the vertical, longitudinal, and transverse positions of its center of gravity (see Guide F 1321 for detailed procedures).

3.1.6 *independent weight and center of gravity estimate, n*—the estimate of light ship weight and centers of gravity performed by the shipbuilder shortly after award of the shipbuilding contract based on the ship design information available at the time of award. When compared with the owner's estimate and upon resolution of differences, an agreed upon weight and center of gravity estimate will result.

3.1.7 *light ship weight, n*—the weight of the ship with all its equipment and outfit, including permanent (fixed) solid or liquid ballast, spare parts that are carried on board, water in boilers at operating levels, machinery including Marine Sanitation Device units in working condition, lubricating oil in all machinery, but not in storage tanks, and liquids in all piping systems.

3.1.8 *longitudinal center of gravity (LCG), n*—the point through which the gravitational forces on a ship pass, measured longitudinally from amidships, measured from the forward perpendicular, or in some cases, measured from the aft perpendicular.

3.1.9 *transverse center of gravity (TCG), n*—the point through which the gravitational forces on a ship pass, measured transversely, port or starboard, from the ship's centerline.

3.1.10 *vertical center of gravity (KG or VCG), n*—the point through which the gravitational forces on a ship pass measured vertically from the keel (K) or the ship's baseline.

3.1.11 *weigh; to weigh, v*—as commonly understood in everyday usage and in the maritime industry, and as used throughout this guide, means to determine by measuring the mass of.

3.1.12 *weight, n*—as commonly understood in everyday usage and in the maritime industry, and as used throughout this guide, is synonymous with mass. In this guide, weight in inch-pound units is measured in pounds and in long tons of 2240 lbs; and in SI units (metric), weight is measured in

¹ This guide is under the jurisdiction of ASTM Committee F-25 on Ships and Marine Technology and is the direct responsibility of Subcommittee F25.07 on General Requirements.

Current edition approved Nov. 10, 1997. Published November 1998.

² *Annual Book of ASTM Standards*, Vol 01.07.

kilograms and in metric tons of 100 kg. Refer to Practice F 1332 for conversion factors to convert inch-pound quantities to SI (metric) quantities for units of weight, moment, moments to trim, and so forth.

3.1.13 *weight classification, n*—the system used in light ship weight estimating for grouping materials, equipment, or components of the ship in a structured order to facilitate comparison and to ensure completeness.

3.1.14 *weight group, n*—one of the three major elements of light ship weight as used in the weight classification, that is, hull structure, outfit, and machinery.

4. Summary of Guide

4.1 *Determination of Weight and Moment Data*—The weight and moment data for all components and material and their overall effect on the ship's weight, center of gravity, list, and trim should be determined. As ship design or ship construction drawings are prepared and as material is selected, acquired, or received, the weight and centers of gravity of all items that comprise the ship should be determined and reported in the weight estimates and reports. These data may be obtained by estimation or calculation during preliminary and contract design, by a combination of estimation or calculation of ship construction drawings, and by actual weight determination of items during detail design and construction.

4.2 *Weight Reporting and Control*—The procedures for weight reporting and control, regardless of the level of reporting, are described in Section 6, and apply for commercial ships. The method and frequency of weight reporting can vary depending on the specific ship design, as well as the technical requirements set forth in the contract. The extent and level of weight control also can vary depending on the specific ship design. Although the weight control technical requirements for commercial ships usually are less demanding than those for U.S. Navy surface ships, the need for a mechanism to control the weight of a ship still exists. Section S-10 describes the specific weight control technical requirements for U.S. Navy surface ships.

5. Significance and Use

5.1 It is important to know the amount of weight and its location before the ship is built to be sure that when it is built it will have positive stability. Only through detailed weight estimating in the design stage and during construction can one be ensured that positive stability will be achieved and retained.

6. Procedure

6.1 A specified number of calendar days, that is, 30, 45, 60, or 90 after date of award, as specified by the owner, the shipbuilder should submit for agreement an independent weight and center of gravity estimate. This estimate should describe the weight and centers of gravity of the ship in

comprehensive detail and should include summaries and work sheets showing the detailed work performed, for example, calculations and estimates based on the design information, drawings, specification, and so forth. Appendix X1 contains suggested forms for the independent estimate, and it includes a suggested weight classification system for the estimate. Terms used in the weight classification are defined in the Maritime Administration Publication, Classification of Merchant Ship Weights.³

6.2 A mutual agreement between the shipbuilder and the owner on the light ship weight and centers of gravity should be reached as quickly as possible after award of the shipbuilding contract. Agreement action should consist of a review of shipbuilder's independent weight and center of gravity estimates and comparison with the owner's estimate. Upon resolution of differences, an agreed upon weight and center of gravity estimate will result. Thereafter, the shipbuilder should be responsible for obtaining in the completed vessel the agreed upon weight and center of gravity characteristics adjusted for authorized departures from the contracted ship design, reflected in the agreed upon estimate.

6.3 Departures from the contracted ship design, reflected in the agreed upon estimate, which affect the light ship weight and centers of gravity, should not be undertaken until the shipbuilder has submitted to the owner his estimate of the effect on weight and centers of gravity of the ship and obtained written approval to proceed with the department. Departures, which have a total impact on any weight group of less than a specified percentage, that is, 0.01, 0.02, 0.03, or 0.04 % of the light ship weight, may be considered negligible and will not require written approval with respect to weight.

6.4 The shipbuilder should submit periodically, as agreed upon, to the owner, a tabulation of approved departures and their cumulative effect on weight and centers of gravity of the agreed light ship estimate. In addition, when submitting plans that involve departures from the type of construction in the contracted ship design, reflected in the estimate, the shipbuilder should itemize such departures and their effect on light ship weight and centers of gravity in his periodic reports. A final report should be submitted at the time of delivery adjusted to bring the estimated light ship weight and centers of gravity into reasonable agreement with the inclining experiment results.

7. Keywords

7.1 light ship; ship acquisition; weight control; weight estimate; weight report

³ U.S. Department of Transportation, Maritime Administration Classification of Merchant Ship Weights, January 1985. Available from the U.S. Maritime Administration, Office of Ship Construction, MAR 720, 400 Seventh St., SW, Washington, DC 20590.

SUPPLEMENTARY REQUIREMENTS

The following supplementary requirements shall apply only when specified by the purchaser in the contract or purchase order. These requirements normally are invoked for U.S. Navy Surface Ships.

S1. SPECIAL GOVERNMENT REQUIREMENTS

S1.1 Government Documents, Drawings, and Publications—The following government documents, drawings, and publications form a part of this guide to the extent specified herein. Unless otherwise specified, the issues are those cited in the solicitation.

S1.1.1 Naval Sea Systems Command (NAVSEA) Documents:

0900-LP-039-9020 Ship Work Breakdown Structure for Nuclear Propulsion Plant (U)⁴

S9040-AA-IDX-010/SWBS 5D, Expanded Ship Work Breakdown Structure, Vol I⁵

S9040-AA-IDX-020/SWBS 5D, Expanded Ship Work Breakdown Structure, Vol II⁵

S1.2 Nongovernment Publications—The following document(s) form a part of this guide to the extent specified herein. Unless otherwise specified, the issues of the documents, which are DOD adopted, are those listed in the issue of the Department of Defense Index of Specifications and Standards (DODISS) cited in the solicitation. Unless otherwise specified, the issues of documents not listed in the DODISS are the issues of the documents cited in the solicitation (see S4.1).

S1.2.1 ANSI Document:⁶

X3.4 Code for Information Interchange

NOTE S00001—Nongovernment standards and other publications normally are available from the organizations that prepare or distribute the documents. These documents also may be available in or through libraries or other informational services.

S1.3 Order of Precedence—In the event of a conflict between the text of this guide and the references cited herein, the text of this guide takes precedence. Nothing in this guide, however, supersedes applicable laws and regulations unless a specific exemption has been obtained.

S2. TERMINOLOGY

S2.1 accepted ship report (ASR), *n*—the ASR is the document that demonstrates the contractor's performance with regard to weight control. The ASR highlights the differences between the accepted weight estimate (AWE) or the allocated baseline weight estimate (ABWE) and the delivered ship as inclined.

S2.2 accepted weight estimate (AWE), *n*—the AWE defines the weight and centers of gravity of a ship that was awarded under a specification-type contract using the information that was available at the time of contract award. It establishes contractual values for weight and KG and is the baseline for detail design and construction.

⁴ Available from the Navy Ships Parts Control Center (SPCC), Code 709 Mechanicsburg, PA 17055.

⁵ Available from Naval Sea Logistics Center, Code 623, PO Box 2060, Mechanicsburg, PA 17055-0795.

⁶ American National Standards Institute, 11 W. 42nd St., 13th Floor, New York, NY 10036.

S2.3 acquisition margins, *n*—acquisition margins are weight and KG allowances included in the weight estimate to cover the inherent limits of precision and the undefined variations of component weight and centers of gravity that take place throughout the design phases and during the construction of a ship. To provide for adequate weight control and configuration control, acquisition margins are divided into five accounts: preliminary design margin, contract design margin, detail design and building margin, contract modification margin, and government-furnished material (GFM) margin.

S2.4 actual weight, *n*—actual weight is the value obtained by a measurement of material on an accurate scale or other weighing device.

S2.5 allocated baseline weight estimate (ABWE), *n*—the ABWE is the contractor's definition of the weight and centers of gravity of a ship that was awarded under a performance-type contract at the time of hull and propulsion configuration approval. It is the baseline for detail design and construction.

S2.6 baseline weight estimate (BWE), *n*—the BWE is any designated weight estimate that is used as a starting point in a design phase for comparative analysis with subsequent weight estimates. Before contract award, the final estimate of each design phase is usually the baseline estimate for the succeeding phase. After contract award, the AWE or ABWE usually is the baseline estimate for the remainder of detail design and construction.

S2.7 bidder's independent weight estimate (BIWE), *n*—the bidder's (or offeror's) independent weight estimate is prepared by each potential contractor in response to a solicitation. It is the bidder's evaluation of the ship design based on the ship specifications, drawings, and data that comprise the contract package.

S2.8 calculated weight, *n*—calculated weight is weight computed from ship construction drawings and vendor drawings.

S2.9 capacity load condition (Condition E), *n*—the capacity load condition is the ship complete and ready for service in every respect. It is light ship (Condition A) plus the following variable loads: maximum number of officers, crew, and passengers that can be accommodated and their effects; maximum stowage of ammunition in magazines and ready service spaces; full allowance of aircraft and vehicles (empty weight with full allowance of repair parts and stores); maximum amount of provisions and stores that can be carried in the assigned spaces; and maximum capacity of liquids in tanks. Fuel and lube oil shall be not greater than 95 % of tank capacity, unless such tanks are compensating. Compensating tanks shall be considered filled with 95 % fuel and 5 % salt water. Maximum amounts of cargo and supplies, other than for ship's own use, shall be included to the full capacity of the assigned spaces. This load condition shall be not greater than the limiting drafts.

S2.10 category, *n*—category is a fundamental unit of machinery weight classification for nuclear-propelled ships in

accordance with NAVSEA 0900-LP-039-9020.

S2.11 *category system, n*—category system is a system of machinery weight classification for nuclear-propelled ships in accordance with NAVSEA 0900-LP-039-9020.

S2.12 *contract data requirements list (CDRL) (DD Form 1423), n*—a CDRL is a contract form listing all data items selected from an authorized data list to be delivered under the contract. It includes the format, content, frequency, submittal, and distribution requirements.

S2.13 *contract design margin, n*—the contract design margin is a weight and KG allowance included in the weight estimate to account for increases associated with design development during the contract design phase. This margin is included in the feasibility and preliminary design phases. No portion of this margin is consumed before the start of contract design.

S2.14 *contract design weight estimates (CDWE), n*—the CDWE is the weight estimate of the light ship, full load, and any other specified loading condition prepared during the contract design phase.

S2.15 *contract modification margin, n*—the contract modification margin is a weight and KG allowance included in the weight estimates and reports to account for increases associated with contract modifications issued during the detail design and construction phase. This margin is included in the feasibility, preliminary, and contract design phases. For performance-type contracts, this margin is also included in detail design and building phase. No portion of this margin is consumed before award of the detail design and construction contract.

S2.16 *contract modification summary, n*—the contract modification summary is a complete listing of the weight and moment effects of approved contract changes. This information is included as an appendix to the quarterly weight reports, the accepted ship report, and the final weight report.

S2.17 *contractor-responsible condition, n*—the contractor-responsible condition is the full-load condition without the effects of contract modifications, changes in GFM, and other allowable changes after the establishment of the AWE or ABWE. This condition is used to measure the contractor's progress in achieving his requirement to deliver the ship within contractual values (see S3.3.4.6).

S2.18 *current weight, n*—current weight consists of the most accurate data available on the date of a given weight estimate or report. The summary of current weight is frequently a combination of estimated, calculated, and actual values.

S2.19 *design and weight data sheet, n*—the design and weight data sheet is a one-page summary that includes group level weight data, hull characteristics data, displacement, and stability characteristics data, load data, and machinery data.

S2.20 *detail design and building margin, n*—detail design and building margin is a weight and KG allowance included in the weight estimates and reports to account for design changes as a result of ship construction drawing development; growth of contractor-furnished material; omissions and errors in the AWE or ABWE, as well as differing shipbuilding practices, omissions and errors in the ship construction drawings; un-

known mill tolerances; outfitting details; variations between the actual ship and its curves of form; and similar differences. This margin is to compensate for all contractor-responsible differences between the AWE or ABWE and the results of the inclining experiment, as well as tolerances for experimental variation in the inclining experiment. This weight and KG allowance is budgeted and included in the feasibility, preliminary, and contract design phases, but no portion of this margin is to be consumed before award of the detail design and construction contract. Values for these margins are to be selected by the offeror and included along with rationale for their basis in BIWEs or PABWEs. The final margin allowances are then subject to negotiation between the government and the contractor that was selected for detail design and construction. The design and building weight margin shall be located at the same center of gravity as the summation of weight groups one through seven.

S2.21 *electronic media, n*—electronic media is used to transfer detailed weight and moment data that complies with the Navy standard weight estimate format and is used by NAVSEA to prepare Navy weight estimates and reports (see Annex A1).

S2.22 *estimated weight, n*—estimated weight is based on preliminary data and is subject to revision when more accurate information is available, such as when more detailed drawings are developed or when components are actually weighed.

S2.23 *expanded ship work breakdown structure (ESWBS), n*—ESWBS is a five-digit functional classification system in accordance with NAVSEA S9040-AA-IDX-010/SWBS 5D and S9040-AA-IDX-020/SWBS 5D (Vol I and II). For weight reporting purposes, only the first three digits of this system apply. The fourth and fifth single digit classification levels are used to incorporate the functions that support maintenance and repair needs.

S2.24 *feasibility study weight estimate, n*—the feasibility study weight estimate is a compilation of the ship's weight and center of gravity data that result in light ship, full load, and any other specified loading conditions. This estimate is prepared during the feasibility study design phase.

S2.25 *final weight report (FWR), n*—a FWR is a detailed final report of weight and moment data for all required loading conditions. This report accurately reflects accumulated values for estimated, calculated, and actual weight data for the detail design, including the net effect of changes to GFM and adjudicated and unadjudicated contract modifications.

S2.26 *full load condition (Condition D), n*—the full-load condition is the ship complete and ready for service in every respect. It is light ship (Condition A), plus the following variable loads: authorized complement of officers, crew, and passengers and their effects; full allowances of ammunition in magazines and ready service spaces; full allowance of aircraft and vehicles (empty weight with full allowance of repair parts and stores); full supply of provisions and stores for the periods specified in the design characteristics; full potable water tanks; lube oil tanks to 95 % of capacity; fuel tanks to 95 % capacity, or in the case of compensating tanks, 95 % fuel and 5 % salt water; sewage collecting, holding, and transfer tanks to 25 % capacity; anti-roll tanks to operating levels; and all other

liquids in tanks to required capacity in accordance with characteristics and liquid-loading instructions. The ammunition, stores, fuel, and other liquids referred to previously are for the ship's own use. Cargo (liquid and solid) is included in the amounts normally carried or to the specified portion of the full capacity of the assigned spaces.

S2.27 government-furnished material (GFM) margin, *n*—the GFM margin is a weight and KG allowance included in the weight estimates and reports to account for increases caused by the growth in GFM during the detail design and construction phase. This margin is included in the feasibility, preliminary, and contract design phases. For performance-type contracts, this margin is also included in detail design and building phase. No portion of this margin is consumed before award of the detail design and construction contract.

S2.28 government-furnished material summary, *n*—the GFM summary is a complete listing of weight and center of gravity data for material and equipment that will be provided by the government. The baseline GFM summary, which is included as part of the AWE or ABWE, reflects the Schedule A portion of the contract at the time of contract award. The GFM summary is continuously updated as the detail design weight estimates mature and the Schedule A is modified. Also, where the contract permits, the GFM summary can include other government-responsible equipment, such as equipment designated as standard for the class, directed procurement, and so forth.

S2.29 group, *n*—group is a fundamental unit of ship classification, identified by one numeric digit or an alphabetic designator. For weight estimates and reports, a group is the first character of the three-digit system. The summation of weights and moments for all of the three-digit elements that begin with the number one is the total for Group one, and similarly for the other groups.

S2.30 gyradius, *n*—the gyradius for roll, pitch, or yaw is the square root of the quotient of the ship's weight moment of inertia about the roll, pitch, and yaw axes, respectively, divided by the ship's displacement.

S2.31 inch-pound units, *n*—inch-pound units comprise a system of units using pounds, long tons, ft, ft-lbs, and ft-tons for reporting mass properties data. These weight and moment data are carried to the nearest pound and ft-lb at all detail levels. In addition, summaries are converted and reported to the nearest one-hundredth of a long ton and to the nearest ft-ton. All levers are carried to the nearest one-hundredth of a foot.

S2.32 KG, *n*—KG is defined as the height of the ship's vertical center of gravity as measured from the bottom of the keel (includes keel thickness). When using SI units, care must be taken not to confuse the naval architectural symbol KG, in uppercase letters, with the SI symbol, kg, in lowercase letters (which represents the SI unit kilogram).

S2.33 light ship condition (Condition A), *n*—the light ship condition is the ship complete, ready for service in every respect, including permanent solid and liquid ballast, onboard repair parts, and liquids in machinery at operating levels, without any items of variable load.

S2.34 longitudinal lever, *n*—the longitudinal lever is the perpendicular distance from a transverse plane through the

ship's longitudinal reference to the center of gravity of an item. The longitudinal reference is located at the forward perpendicular, unless otherwise specified by the design contract or Ship Specification Section 096.

S2.35 magnetic media, *n*—magnetic media is used to transfer detailed weight and moment data that complies with the Navy standard weight estimate format and is used by NAVSEA to prepare Navy weight estimates and reports (see Annex A1).

S2.36 mass properties data, *n*—mass properties data are those physical characteristics that define the magnitude, location, and distribution of weight in the ship. They include weight, centers of gravity location, moments, and weight moments of inertia.

S2.37 metric units, *n*—metric units comprise a system of basic measures that are defined by the International System of Units based on "Le Systeme International d'Unites (SI)" of the International Bureau of Weights and Measures.

S2.38 moment, *n*—a moment is the product of a weight and its lever. For example, the longitudinal moment of an item is the product of the weight of the item multiplied by its longitudinal lever.

S2.39 percent completion, *n*—percent completion is the ratio of the current weight, less the current estimated weight, to the current weight, expressed as a percentage.

S2.40 performance-type contract, *n*—a performance-type contract is the vehicle for ship acquisition resulting from a description of operational and mission requirements. Since the shipbuilder usually has substantial latitude in determining ship size and configuration, a PABWE or ABWE is used in this situation.

S2.41 pitch moment of inertia, *n*—moment of inertia about the transverse axis through the ship's center of gravity.

S2.42 preliminary allocated baseline weight estimate (PABWE), *n*—the PABWE is the potential bidder's (or offeror's) estimate of the weight and center of gravity of the ship in response to a solicitation for a performance-type contract.

S2.43 preliminary design margin, *n*—preliminary design margin is a weight and KG allowance included in the weight estimates to account for increases associated with design development during the preliminary design phase. This margin is included in the feasibility design phase. No portion of this margin is consumed before the start of preliminary design.

S2.44 preliminary design weight estimate, *n*—preliminary design weight estimate is the weight estimate of the light ship, full load, and any other specified load condition prepared during the preliminary design phase.

S2.45 quarterly weight report (QWR), *n*—a QWR is a periodic assessment of displacement, drafts, trim, list, GM, and KG as the weight estimate matures during detail design and construction.

S2.46 roll moment of inertia, *n*—moment of inertia about the longitudinal axis through the ship's center of gravity.

S2.47 service life allowances, *n*—service life allowances are weight and KG budgets included in the design to accommodate changes as a result of both authorized (for example, ship alterations) and unplanned growth (for example, paint, personal belongings, and so forth) during the ship's operational

lifetime, which tends to increase displacement and impact stability.

S2.48 *SI units (International System of Units), n*—SI units (see Practice F 1332) comprise a system of units using kg, metric tons, m, kg/m, and metric ton-m for reporting mass properties data. All levers are carried to the nearest one-hundredth of a m. The weight and moment data are carried to the nearest kg and kg/m at all detail levels. In addition, summaries are converted and reported to the nearest one-hundredth of a metric ton and to the nearest metric ton-m.

S2.49 *specification-type contract, n*—a specification-type contract is the vehicle for ship acquisition resulting from a Navy controlled contract design. The products of the contract design, which usually become part of the shipbuilding contract and therefore the basis for the BIWE, include items such as: midship section drawing, lines drawing, table of offsets, general arrangement drawings, the shipbuilding specifications, and special requirements like not-to-exceed weight and KG values.

S2.50 *standard longitudinal station breakdown, n*—the standard longitudinal station breakdown is a system consisting of 22 stations designated by the letters A through X (excluding I and O). Station A is the only station forward of the forward perpendicular (FP). Station X is the only station aft of the aft perpendicular (AP). Stations B through W extend from the FP

to the AP, and each comprises 1/20 of the length between perpendiculars.

S2.51 *three-digit system, n*—The three-digit system is a means of classifying mass properties data in a structured order. Every item that comprises the completed ship is included in the weight estimates and reports grouped in accordance with the three-digit system. Unless otherwise specified, the three-digit system for weight estimates and reports is the same as the first three digits of the ESWBS. An example of this numerical ordering is shown in Fig. S2.1.

S2.52 *transverse lever, n*—transverse lever is the perpendicular distance from the vertical centerline plane of the ship to the center of gravity of an item.

S2.53 *vertical lever, n*—vertical lever is the perpendicular distance from a horizontal plane through the molded baseline of the ship to the center of gravity of an item.

S2.54 *weight control, n*—weight control is all of the necessary actions, such as predicting, estimating, calculating, weighing, reporting, analyzing, evaluating, and reversing adverse trends to ensure that a ship's weight and moments are consistent with its naval architectural limits for displacement, strength, stability, list, trim, and performance, such as speed, endurance, and seakeeping.

S2.55 *weight control plan, n*—a weight control plan outlines the procedures that will be followed to meet contractual

UNCLASSIFIED		SHIP USS SAMPLE		WEIGHT AND MOMENT ESTIMATE		REPORT NO. 01							
PREPARED BY 55W2		INCH-POUND UNITS		POUNDS, TONS, FEET		3 JANUARY 1989							
		LONGITUDINAL REFERENCE IS		-250.00 FROM MID PERPENDICULAR		SHEET 15							
NAVY C	S		UNIT NO.	CURRENT E	VERTICAL	LONGITUDINAL	TRANSVERSE	RCG R					
GROUP	ITEM	DESCRIPTION	WEIGHT UNITS	WEIGHT A	VCG	MOMENT	LCG S	MOMENT	EHF P				
	DM								SGM T				
3		ELECTRIC PLANT											
31100	0 A	SHIPS SERVICE PWR GEN.	205186										
31100	10 N	SSTG GEN 2 ENG RM 2 #81	67750	67750.00	1	67750.C	19.01	1287928.	277.47A	18798592.	8.05S	-545388.	E3602
31100	20 S	SSTG GEN 3 GEN RM #82	67750	67750.00	1	67750.C	20.83	1411233.	394.05A	26696886.	4.12P	279130.	E3602
31100	30 G	SSTG GEN 1 AMR T #80	67750	67750.00	1	67750.C	10.50	711375.	149.95A	10159112.	2.30P	155825.	E3602
31100	40 H	SCAVENGE PUMP & AIR SEAL AMR#1	140.00	140.00	1	140.E	11.00	1540.	150.70A	21098.	2.30P	322.M	01
31100	50 N	SCAVENGE PUMP & AIR SEAL ENG RM2	300.00	300.00	2	600.E	22.00	13200.	284.75A	170850.	12.50P	2500.M	01
31100	60 M	SPARE BATTERIES FOR NBPS	51.00	51.00	1	51.E	34.50	1760.	259.00A	13209.	22.00P	1122.	01
31100	70 Q	ENCLOSED BATTERY RACK	100.00	100.00	1	100.E	17.25	1725.	326.00A	32600.	0.00	0.	01
31100	80 Q	BATTERIES	55.00	55.00	1	55.E	17.25	949.	326.00A	17930.	0.00	0.	01
31100	90 Q	BATTERY CHARGER	90.00	90.00	1	90.E	18.25	1643.	326.00A	29340.	0.00	0.	01
31100	100 K	MONORAIL	800.00	800.00	1	800.E	50.00	40000.	215.00A	172000.	13.00S	-10400.	01
31100	110 F	ENCLOSED BATTERY RACK	100.00	100.00	1	100.E	8.50	850.	103.00A	10300.	0.00	0.	01
		SUBTOTAL - POUNDS		205186.				3472201.		56121920.		-111889.	
		SUBTOTAL - TONS		91.60	16.92			1550.	273.52A	25054.	0.55S	-50.	
311		SHIPS SERVICE POWER GENERATION											
		GROUP TOTAL - POUNDS		205186.				3472201.		56121920.		-111889.	
		GROUP TOTAL - TONS		91.60	16.92			1550.	273.52A	25054.	0.55S	-50.	

UNCLASSIFIED

Note: Inch-pound units are shown in example, however SI units are applicable when specified.

FIG. S2.1 Example of a Three-Digit System Format

weight control responsibilities (see S3.3.3.5).

S2.56 *weight distribution, n*—a weight distribution is a weight summary by the standard longitudinal station breakdown and is used to develop shear forces and bending moments.

S2.57 *weight moment of inertia, n*—weight moment of inertia about any reference axis through the ship’s center of gravity is the summation of the moment of inertia of each item about its own axis (parallel to the reference inertia axis), plus the products obtained by multiplying the weight of each item by the square of its distance from the reference inertia axis (see S3.3.2.3).

S2.58 *weight reporting, n*—weight reporting is the preparation and submission of the most accurate and current weight and moment data available at designated intervals throughout the design and construction phases.

S2.59 *yaw moment of inertia, n*—moment of inertia about the vertical axis through the ship’s center of gravity.

S3. PROCEDURES

S3.1 *General Report Requirements*—The contract will invoke this guide and specify technical data to be prepared, including modifications and exceptions. The CDRL will specify requirements for deliverables, such as data to be submitted, frequency of submission, number of copies, and recipients. The general requirements for the weight estimates and reports listed in this standard are specified in S3.1.1 through S3.2. The interface of weight estimates and reports is depicted in Fig. S3.1.

S3.1.1 *Loading Conditions*—Weight estimates and reports shall contain loading conditions for light ship, full load, and contractor responsibility, unless otherwise specified by the contract. The light ship condition includes a summary of one-digit groups and the remaining acquisition margin. These values are combined to result in the light ship weight, centers of gravity, and associated moments. The light ship condition in the FWR shall be adjusted to correlate with inclining experiment data. Building margin is used to account for irreconcilable differences between the FWR and the inclining experiment. Building margin is the only acquisition margin account that is permitted in the FWR. Other margin accounts, such as detail design margin, will either be fully depleted or if remainders exist they should be deleted from the FWR. The full-load condition is computed by adding specified items of variable load to the light ship condition and reflects the actual ship that is planned for delivery. The contractor-responsible condition is the full-load condition without the effect of contract modifications, both adjudicated and unadjudicated; the net weight change and associated moment changes from baseline values of current GFM items that were included in the original Schedule A or were subsequently added to Schedule A through a change in acquisition responsibility; and other allowable changes beyond the control of the contractor (see S3.3.4.6). This condition is used to assess contractual performance. In addition to the total weight, centers of gravity, and associated moments, each loading condition also shall display KG, metacentric height (uncorrected and corrected for the free

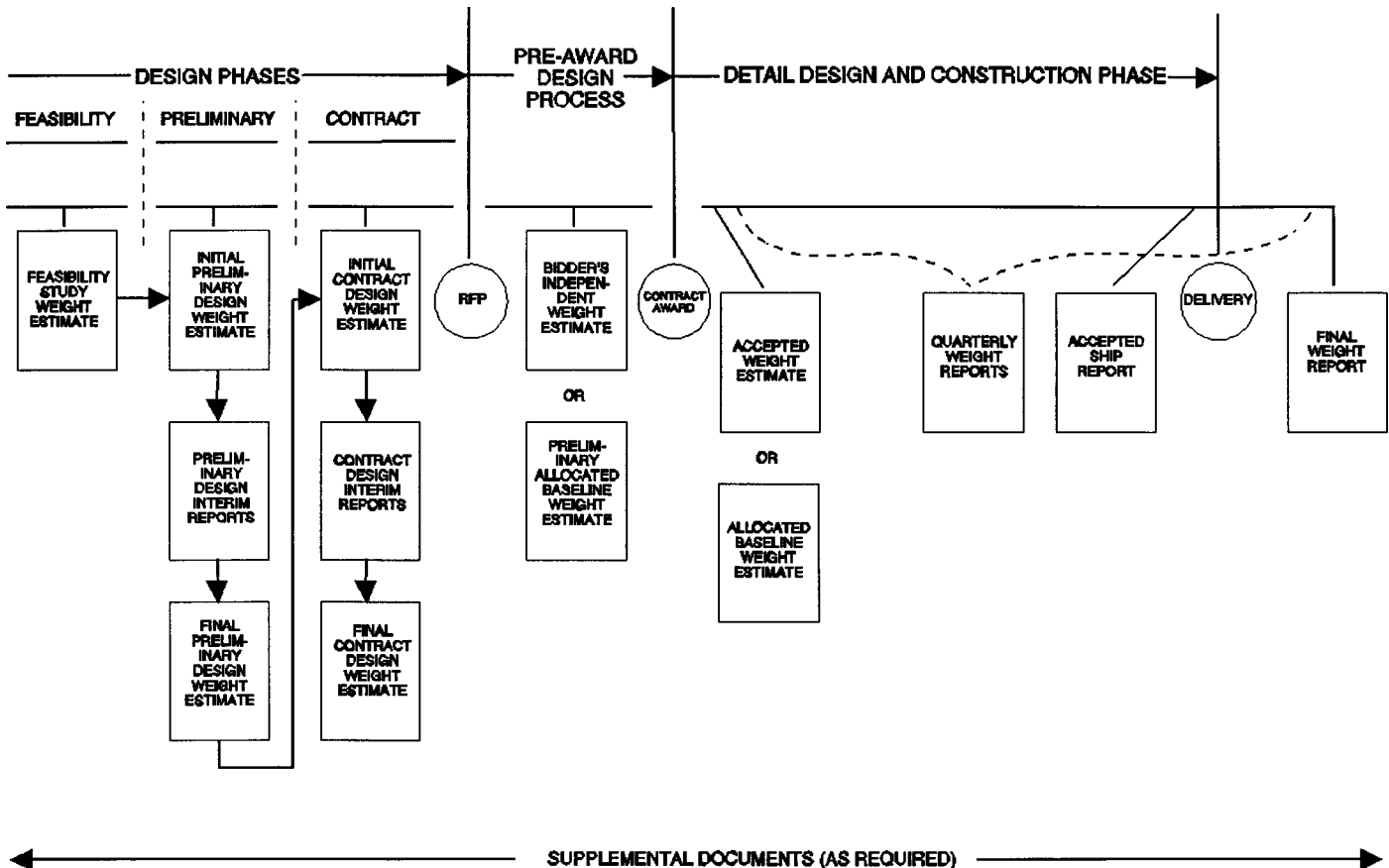

FIG. S3.1 Interface of Weight Reporting During Design and Construction

surface effect of liquids in tanks), list, trim, and drafts above the bottom of the keel at the perpendiculars and midship. Figs. S3.2-S3.4 provide examples of typical loading conditions.

S3.1.2 *Margins*—Acquisition margins shall be included in the estimates and reports. Throughout the design cycle, the appropriate margin account shall be adjusted concurrently to compensate for departures from the original estimates. This computation permits the maintenance of a constant design baseline until the budgeted margin account is exceeded. Weight margins shall be located at the same centers of gravity as the ESWBS current one-digit totals. Fig. S3.5 provides a typical example.

S3.1.3 *Reasons for Changes*—Weight estimates and reports shall include an addendum that explains each cause of significant change in weight or moment within every three-digit element. Unless otherwise specified, a significant change is a 1 % or greater difference from an element’s previous estimate. A brief narrative of the ship’s condition relative to its naval architectural or contractual limits shall be included in this section. If any of these limits is in jeopardy, recommendations for reversing the adverse trend are also required.

S3.1.4 *Table of Contents*—The estimates and reports shall contain a table of contents.

S3.1.5 *Special Coding*—An explanatory note and remarks section shall be included to define special coding symbols,

such as material codes, GFM indicators, and reasons for change indicators.

S3.1.6 *Lever Symbol*—Vertical levers shall be indicated by a “-” for below the baseline and a “+” or a blank for above the baseline. Longitudinal levers shall be indicated by an “F” or a “-” for forward of the reference plane and an “A,” a “+,” or a blank for aft of the reference plane. Transverse levers shall be indicated by a “P,” a “+,” or a blank for port and an “S” or a “-” for starboard.

S3.1.7 *Reporting System Units*—Estimates, reports, and other specified mass properties documentation and data shall be reported in either inch-pound or metric units as specified in the contract.

S3.1.8 *Paper*—Estimates and reports shall be machine written on 8-1/2- by 11-in. paper, and protected by hard covers, but not permanently bound. The original or reproducible copy shall be suitable for microfilming.

S3.1.9 *Supporting Documents*—Background information, studies, directives, correspondence, and all detail calculations pertaining to weight and moment data, including density factors, shall be made available to the Navy upon request.

S3.2 *Classified Reports*—Weight reports containing classified data shall be marked in accordance with the security requirements contained in the contract. Whenever possible, classified or proprietary material shall be downgraded by

UNCLASSIFIED										
SHIP USS SAMPLE		WEIGHT AND MOMENT ESTIMATE							REPORT NO. 01	
PREPARED BY 55W2		INCH-POUND UNITS POUNDS, TONS, FEET							3 JANUARY 1989	
		LONGITUDINAL REFERENCE IS -250.00 FROM MID PERPENDICULAR							SHEET 2M	
NAVY GROUP	DESCRIPTION	PERCENT EST.	COMPLETE CALC.	ACTUAL	CURRENT WEIGHT	VERTICAL VCG	LONGITUDINAL LCG S	TRANSVERSE TCG S	LONGITUDINAL MOMENT	TRANSVERSE MOMENT
SUMMARY LIGHTSHIP CONDITION WITH MARGINS										
	GROUPS 1 - 7	100	0	0	6608.29	26.68	176303.	229.34A	1515522.	0.02S -111.
M	MARGINS	100	0	0	264.33	26.68 1.07	7052.	229.34A	60621.	0.02S -4.
	GROUPS 1 - 7 WITH MARGINS				6872.62	27.75	190689	229.34A	1576143.	0.02S -116.
L	LOADS	100	0	0	0.00	0.00	0.	0.00	0.	0.00 0.
	LIGHT SHIP CONDITION	100	0	0	6872.62	27.75	190689	229.34A	1576143.	0.02S -116.
NOTE: ALL OF THE FOLLOWING QUANTITIES (EXCEPT AS NOTED) ARE REFERENCED FROM 250.00 FEET FWD OF THE MID PERPENDICULAR, THE CENTER LINE, AND THE BASE LINE.										
1.	LENGTH BETWEEN PERPENDICULARS	500.00	FEET							
2.	BOTTOM OF KEEL BELOW BASE LINE	0.06	FEET							
3.	C.G. ABOVE BOTTOM OF KEEL . . .	27.81	FEET							
4.	C.G. ABOVE BASE LINE	27.75	FEET							
5.	DRAFT AT L.C.F. FOR ABOVE DISP.	17.98	FEET							
6.	TONS PER INCH IMMERSION	48.55	TONS/INCH							
7.	TRANSVERSE METACENTER (KEEL) .	28.80	FEET							
8.	GM, WITHOUT FREE SURFACE CORR.	0.99	FEET							
9.	FREE SURFACE CORRECTION	0.00	FEET							
10.	GM, WITH FREE SURFACE CORR. . .	0.99	FEET							
11.	MOMENT TO ALTER HEEL ONE DEGREE	119.20	FOOT-TONS							
12.	LIST	0.97	DEGREES STBD							
13.	MOMENT TO ALTER TRIM ONE INCH	1283.88	FOOT-TONS							
14.	L.C.B. ON EVEN KEEL AT ABV DRAFT	246.93	FEET AFT							
15.	LONGITUDINAL CENTER OF GRAVITY	229.34	FEET AFT							
16.	TRIMMING LEVER	17.59	FEET FWD							
17.	TRIM	7.85	FEET BY HEAD							
18.	L.C.F.	270.77	FEET AFT							
19.	DIFF IN DRAFT, L.C.F. TO MIDSHIP	0.33	FEET INCREASE							
20.	DRAFTS:									
	FORWARD PERPENDICULAR	22.24	FEET							
	MEAN	18.31	FEET							
	AFT PERPENDICULAR	14.39	FEET							
21.	DESIGNED DRAG	0.00	FEET							

Note: Inch-pound units are shown in example, however SI units are applicable when specified.

UNCLASSIFIED

FIG. S3.2 Example of Light Ship Condition Format

UNCLASSIFIED		WEIGHT AND MOMENT ESTIMATE						REPORT NO. 01			
SHIP USS SAMPLE		INCH-POUND UNITS						3 JANUARY 1989			
PREPARED BY 55W2		LONGITUDINAL REFERENCE IS -250.00 FROM MID PERPENDICULAR						SHEET 1M			
NAVY GROUP	DESCRIPTION	PERCENT EST.	COMPLETE CALC.	CURRENT WEIGHT	VERTICAL VCG	LONGITUDINAL LCG S	TRANSVERSE TCG S	MOMENT			
SUMMARY FULL LOAD CONDITION WITH MARGINS											
	GROUPS 1 - 7	100	0	0	6608.29	26.68	176303.	229.34A	1515522.	0.02S	-111.
M	MARGINS	100	0	0	264.33	26.68	7052.	229.34A	60621.	0.02S	-4.
						1.07	7334.				
	GROUPS 1 - 7 WITH MARGINS				6872.62	27.75	190689	229.34A	1576143.	0.02S	-116.
F	LOADS, FULL	100	0	0	1674.07	11.33	18973.	258.54A	432809.	0.16P	264.
	FULL LOAD CONDITION WITH MARGINS	100	0	0	8546.69	24.53	209662	235.06A	2008952.	0.02P	148.
NOTE: ALL OF THE FOLLOWING QUANTITIES (EXCEPT AS NOTED) ARE REFERENCED FROM 250.00 FEET FWD OF THE MID PERPENDICULAR, THE CENTER LINE, AND THE BASE LINE.											
1.	LENGTH BETWEEN PERPENDICULARS	500.00	FEET						1453.19	FOOT-TONS	
2.	BOTTOM OF KEEL BELOW BASE LINE	0.06	FEET						251.96	FEET	AFT
3.	C.G. ABOVE BOTTOM OF KEEL	24.59	FEET						235.06	FEET	AFT
4.	C.G. ABOVE BASE LINE	24.53	FEET						16.90	FEET	FWD
5.	DRAFT AT L.C.F. FOR ABOVE DISP.	20.75	FEET						8.28	FEET	BY HEAD
6.	TONS PER INCH IMMERSION	51.68	TONS/INCH								
7.	TRANSVERSE METACENTER (KEEL)	29.00	FEET						273.31	FEET	AFT
8.	GM, WITHOUT FREE SURFACE CORR.	4.41	FEET						0.39	FEET	INCREASE
9.	FREE SURFACE CORRECTION	0.16	FEET								
10.	GM, WITH FREE SURFACE CORR.	4.25	FEET								
11.	MOMENT TO ALTER HEEL ONE DEGREE	633.76	FOOT-TONS								
12.	LIST	0.23	DEGREES PORT								
13.	MOMENT TO ALTER TRIM ONE INCH										
14.	L.C.B. ON EVEN KEEL AT ABV DRAFT										
15.	LONGITUDINAL CENTER OF GRAVITY										
16.	TRIMMING LEVER										
17.	TRIM										
18.	L.C.F.										
19.	DIFF IN DRAFT, L.C.F. TO MIDSHIP										
20.	DRAFTS:										
	FORWARD PERPENDICULAR								25.28	FEET	
	MEAN								21.14	FEET	
	AFT PERPENDICULAR								17.00	FEET	
21.	DESIGNED DRAG								0.00	FEET	

Note: Inch-pound units are shown in example, however SI units are applicable when specified.

UNCLASSIFIED

FIG. S3.3 Example of Full-Load Condition Format

deleting classified or proprietary portions that do not impair the usefulness of the document.

S3.3 Detailed Requirements:

S3.3.1 Predetail Design Phase—Estimates, reports, and supplemental documents for these design phases shall be prepared in accordance with S3.3.1.1 through S3.3.2.11, as applicable, unless otherwise specified.

S3.3.1.1 Weight Estimates and Reports—Weight estimates and reports prepared during these phases consist of baseline weight estimates, interim reports, and final design weight estimates. These estimates and reports contain detailed information appropriate to the design phase, loading conditions for light ship and full load, and are summarized in tabular form as follows:

- (a) Three-digit system number and title.
- (b) Current weight.
- (c) Current vertical lever.
- (d) Current vertical moment.
- (e) Current longitudinal lever.
- (f) Current longitudinal moment.
- (g) Current transverse lever.
- (h) Current transverse moment.

The mass properties data included in these estimates and reports are based on the engineering products available before the date of the document.

S3.3.1.2 Baseline Weight Estimates—The initial estimate

for a given design phase is designated the baseline weight estimate. The baseline weight estimate consists of the light ship, full load, and any other specified loading condition. The estimate shall be titled Baseline Preliminary or Baseline Contract Design Weight Estimate. The requirements for the estimate are as specified in S3.3.1.1.

S3.3.1.3 Interim Reports—Weight estimates produced at specified intervals during a given design phase are designated interim weight reports. The interim report summarizes the current weight and moment status of the design and highlights any changes that occurred during the reporting period. The report shall contain the light ship, full load, and any other specified loading condition. It also shall reflect the appropriate title, such as Preliminary Design Interim Report No. 2. Fig. S3.6 and Fig. S3.7 provide typical examples. In addition to the requirements specified in S3.3.1.1, the report shall contain the following:

- (a) Previous design phase group level summary.
- (b) Previous report group level summary.
- (c) Current group level estimate, and when required, the element level estimate and longitudinal weight distribution data.
- (d) Net change, by group and total, between (a) and (c).
- (e) Net change, by group and total, between (b) and (c).
- (f) The current status of margins, loads, full-load displacement, KG, list, and trim. The changes corresponding to the

UNCLASSIFIED		WEIGHT AND MOMENT ESTIMATE							REPORT NO. 01																																																										
SHIP USS SAMPLE		INCH-POUND UNITS POUNDS, TONS, FEET							3 JANUARY 1989																																																										
PREPARED BY 55W2		LONGITUDINAL REFERENCE IS -250.00 FROM MID PERPENDICULAR							SHEET 1M																																																										
NAVY GROUP	DESCRIPTION	PERCENT EST.	COMPLETE CALC.	ACTUAL	CURRENT WEIGHT	VERTICAL VCG	MOMENT	LONGITUDINAL LCG S	MOMENT	TRANSVERSE TCG S	MOMENT																																																								
SUMMARY																																																																			
CONTRACTOR RESPONSIBLE CONDITION																																																																			
FULL LOAD		100	0	0	8546.69	24.53	209662.	235.06A	2008952.	0.02P	148.																																																								
EFFECT OF COM MODS		100	0	0	-15.00	30.13	-452.	265.98A	-3990.	2.37S	36.																																																								
EFFECT OF GFM WEIGHT CHANGES		100	0	0	-6.25	23.04	-144.	135.36A	-846.	0.80P	-5.																																																								
EFFECT OF CLASS STANDARD EQPT		100	0	0	-20.00	18.28	-366.	295.74A	-5915.	0.18P	-4.																																																								
CONTRACTOR RESPONSIBLE CONDITION		100	0	0	8503.79	24.53	208623.	234.93A	1997772.	0.02P	176.																																																								
<p>NOTE: ALL OF THE FOLLOWING QUANTITIES (EXCEPT AS NOTED) ARE REFERENCED FROM 250.00 FEET FWD OF THE MID PERPENDICULAR, THE CENTER LINE, AND THE BASE LINE.</p> <table border="0"> <tr> <td>1. LENGTH BETWEEN PERPENDICULARS</td> <td>500.00 FEET</td> <td>13. MOMENT TO ALTER TRIM ONE INCH</td> <td>1450.17 FOOT-TONS</td> </tr> <tr> <td>2. BOTTOM OF KEEL BELOW BASE LINE</td> <td>0.06 FEET</td> <td>14. L.C.B. ON EVEN KEEL AT ABV DRAFT</td> <td>251.85 FEET AFT</td> </tr> <tr> <td>3. C.G. ABOVE BOTTOM OF KEEL</td> <td>24.59 FEET</td> <td>15. LONGITUDINAL CENTER OF GRAVITY</td> <td>234.93 FEET AFT</td> </tr> <tr> <td>4. C.G. ABOVE BASE LINE</td> <td>24.53 FEET</td> <td>16. TRIMMING LEVER</td> <td>16.92 FEET FWD</td> </tr> <tr> <td>5. DRAFT AT L.C.F. FOR ABOVE DISP.</td> <td>20.69 FEET</td> <td>17. TRIM</td> <td>8.27 FEET BY HEAD</td> </tr> <tr> <td>6. TONS PER INCH IMMERSION</td> <td>51.62 TONS/INCH</td> <td></td> <td></td> </tr> <tr> <td></td> <td></td> <td>18. L.C.F.</td> <td>273.30 FEET AFT</td> </tr> <tr> <td>7. TRANSVERSE METACENTER (KEEL)</td> <td>29.00 FEET</td> <td>19. DIFF IN DRAFT, L.C.F. TO MIDSHIP</td> <td>0.39 FEET INCREASE</td> </tr> <tr> <td>8. GM, WITHOUT FREE SURFACE CORR.</td> <td>4.41 FEET</td> <td>20. DRAFTS:</td> <td></td> </tr> <tr> <td>9. FREE SURFACE CORRECTION</td> <td>0.16 FEET</td> <td> FORWARD PERPENDICULAR</td> <td>25.22 FEET</td> </tr> <tr> <td>10. GM, WITH FREE SURFACE CORR.</td> <td>4.25 FEET</td> <td> MEAN</td> <td>21.08 FEET</td> </tr> <tr> <td></td> <td></td> <td> AFT PERPENDICULAR</td> <td>16.95 FEET</td> </tr> <tr> <td>11. MOMENT TO ALTER HEEL ONE DEGREE</td> <td>630.34 FOOT-TONS</td> <td>21. DESIGNED DRAG</td> <td>0.00 FEET</td> </tr> <tr> <td>12. LIST</td> <td>0.28 DEGREES PORT</td> <td></td> <td></td> </tr> </table>												1. LENGTH BETWEEN PERPENDICULARS	500.00 FEET	13. MOMENT TO ALTER TRIM ONE INCH	1450.17 FOOT-TONS	2. BOTTOM OF KEEL BELOW BASE LINE	0.06 FEET	14. L.C.B. ON EVEN KEEL AT ABV DRAFT	251.85 FEET AFT	3. C.G. ABOVE BOTTOM OF KEEL	24.59 FEET	15. LONGITUDINAL CENTER OF GRAVITY	234.93 FEET AFT	4. C.G. ABOVE BASE LINE	24.53 FEET	16. TRIMMING LEVER	16.92 FEET FWD	5. DRAFT AT L.C.F. FOR ABOVE DISP.	20.69 FEET	17. TRIM	8.27 FEET BY HEAD	6. TONS PER INCH IMMERSION	51.62 TONS/INCH					18. L.C.F.	273.30 FEET AFT	7. TRANSVERSE METACENTER (KEEL)	29.00 FEET	19. DIFF IN DRAFT, L.C.F. TO MIDSHIP	0.39 FEET INCREASE	8. GM, WITHOUT FREE SURFACE CORR.	4.41 FEET	20. DRAFTS:		9. FREE SURFACE CORRECTION	0.16 FEET	FORWARD PERPENDICULAR	25.22 FEET	10. GM, WITH FREE SURFACE CORR.	4.25 FEET	MEAN	21.08 FEET			AFT PERPENDICULAR	16.95 FEET	11. MOMENT TO ALTER HEEL ONE DEGREE	630.34 FOOT-TONS	21. DESIGNED DRAG	0.00 FEET	12. LIST	0.28 DEGREES PORT		
1. LENGTH BETWEEN PERPENDICULARS	500.00 FEET	13. MOMENT TO ALTER TRIM ONE INCH	1450.17 FOOT-TONS																																																																
2. BOTTOM OF KEEL BELOW BASE LINE	0.06 FEET	14. L.C.B. ON EVEN KEEL AT ABV DRAFT	251.85 FEET AFT																																																																
3. C.G. ABOVE BOTTOM OF KEEL	24.59 FEET	15. LONGITUDINAL CENTER OF GRAVITY	234.93 FEET AFT																																																																
4. C.G. ABOVE BASE LINE	24.53 FEET	16. TRIMMING LEVER	16.92 FEET FWD																																																																
5. DRAFT AT L.C.F. FOR ABOVE DISP.	20.69 FEET	17. TRIM	8.27 FEET BY HEAD																																																																
6. TONS PER INCH IMMERSION	51.62 TONS/INCH																																																																		
		18. L.C.F.	273.30 FEET AFT																																																																
7. TRANSVERSE METACENTER (KEEL)	29.00 FEET	19. DIFF IN DRAFT, L.C.F. TO MIDSHIP	0.39 FEET INCREASE																																																																
8. GM, WITHOUT FREE SURFACE CORR.	4.41 FEET	20. DRAFTS:																																																																	
9. FREE SURFACE CORRECTION	0.16 FEET	FORWARD PERPENDICULAR	25.22 FEET																																																																
10. GM, WITH FREE SURFACE CORR.	4.25 FEET	MEAN	21.08 FEET																																																																
		AFT PERPENDICULAR	16.95 FEET																																																																
11. MOMENT TO ALTER HEEL ONE DEGREE	630.34 FOOT-TONS	21. DESIGNED DRAG	0.00 FEET																																																																
12. LIST	0.28 DEGREES PORT																																																																		
<p>Note: Inch-pound units are shown in example, however SI units are applicable when specified.</p>										UNCLASSIFIED																																																									

FIG. S3.4 Example of Contractor-Responsible Condition Format

total net change calculated for (d) and (e) shall be shown for margins, loads, and full-load displacement.

(g) A brief narrative providing rationale for any significant changes since the previous report and classified by the groups in which the changes occurred.

S3.3.1.4 Final Design Weight Estimate—The final estimate produced during a design phase is designated as the final design weight estimate. This estimate will reflect the final weight and moment data for light ship, full load, and any other specified loading condition. The estimate shall be titled Final Preliminary or Final Contract Design Weight Estimate. The requirements for the estimate are specified in S3.3.1.1 and S3.3.1.3.

S3.3.2 Supplemental Documents—The supplemental documents specified in S3.3.2.1 through S3.3.2.11 shall provide additional information and background data required during the preliminary/contract design phases.

S3.3.2.1 Weight and Moment Trade-Off Studies—These studies consist of determining the mass properties impact of various configuration change proposals and engineering alternatives that are being considered for inclusion in the design. The studies are delivered on an “as requested” basis and contain detailed mass properties calculations that define the impact of the study on ship displacement, KG, list, and trim. There is no fixed format for the completed study, but the ESWBS classification system shall be used to structure and summarize the data.

S3.3.2.2 Weight Distribution Report—A longitudinal weight distribution shall be provided in a tabulated format in accordance with the standard longitudinal station breakdown. Weight and longitudinal center of gravity shall be determined for each ship station for both light ship and full-load condition. The resultant total weight and longitudinal center of gravity for the weight distribution report for each condition shall equal the values reflected in the weight estimate or report for the same condition in that reporting period.

S3.3.2.3 Weight Moment of Inertia—When specifically required by the contract, weight moment of inertia data shall be included for the full-load condition. Current weights, centers of gravity, and engineering information describing the shape and orientation of each data element shall be used to develop weight moment of inertia data. The minimum data required are as follows:

(a) Ship-oriented roll, pitch, and yaw weight moments of inertia about each individual data element’s centroidal axes.

(b) Ship-oriented roll, pitch, and yaw weight moments of inertia about the ship’s centroid in the full-load condition.

S3.3.2.4 Ship Specification Sections—Ship specification sections shall define the requirements of the weight control program and the range of acceptable trim and list limit values that are to be invoked upon the shipbuilder. Deviations from this standard, such as special loading conditions, reporting units, or margins, shall be defined clearly. The format for the specification sections will be provided by NAVSEA.

UNCLASSIFIED

SHIP USS SAMPLE
PREPARED BY 55W2

WEIGHT AND MOMENT ESTIMATE

REPORT NO. 01
3 JANUARY 1989

INCH-POUND UNITS POUNDS, TONS, FEET
LONGITUDINAL REFERENCE IS -250.00 FROM MID PERPENDICULAR

SHEET 26

NAVY C T DM S
GROUP ITEM A DESCRIPTION UNIT NO. CURRENT C VERTICAL LONGITUDINAL TRANSVERSE RCG R
WEIGHT UNITS WEIGHT A VCG MOMENT LCG S MOMENT TCG S MOMENT EHF P SGM T

M		DESIGN AND BUILDING MARG	UNIT NO.	CURRENT C	VERTICAL	LONGITUDINAL	TRANSVERSE	RCG R	
M1200	0 *	DESIGN AND BUILDING MARGIN							
M1200	10 0	WEIGHT MARGIN	4.00	592102.	26.68	15796738.	229.34A135790800.	-0.02S	-9976.
M1200	20 0	VCG MARGIN	0.00	0.	0.00	16428606.	0.00	0.	0.
		SUBTOTAL POUNDS		592102.		32225344.	135790800.		-9976.
		SUBTOTAL TONS		264.33	54.43	14386.	229.34A	0.02S	-4.
M12		DESIGN AND BUILDING MARGIN							
		GROUP TOTAL POUNDS		592102.		32225344.	135790800.		-9976.
		GROUP TOTAL TONS		264.33	54.43	14386.	229.34A	0.02S	-4.

Note: Inch-pound units are shown in example, however SI units are applicable when specified.

UNCLASSIFIED

FIG. S3.5 Example of Margins Format

S3.3.2.5 *Circular of Requirements Sections*—These sections shall provide the weight control requirements when a performance-type contract is used. The content of these sections shall be similar to S3.3.2.4, with the addition of service-life allowance quantities.

S3.3.2.6 *Contract Data Requirements List (CDRL)*—A CDRL will be developed that itemizes the data deliverables that shall be required by the ship acquisition contract. The portion of the CDRL that contains weight estimates, reports, and supplemental documents shall be generated during the contract design phase (see S4.2).

S3.3.2.7 *Solicitation Input*—A request for proposals or similar document shall be prepared that describes the ship design to potential shipbuilders and defines the format for submitting a bid or making an offer. The following portions of the solicitation package that pertain to weight control shall be generated during contract design:

(a) *Instructions to Offerors*—This section describes the content of the weight control material that will be submitted for source selection consideration. The bidder's Independent Weight Estimate or Preliminary Allocated Baseline Weight Estimate, Preliminary Weight Control Plan, and resumes of weight control personnel are typical examples.

(b) *Factors for Determining Loads*—These are allowances, densities, and stowage factors that are used in the variable load portion of the full-load condition are included in the solicita-

tion to permit a consistent calculation of load items by the bidders or offerors.

(c) *Weights for Schedule A Items*—This listing establishes the baseline GFM weight that will be required in the AWE/ABWE.

S3.3.2.8 *Weight Control Contract Clause*—The contract clause for weight control shall be provided for inclusion in the shipbuilding contract. The clause shall contain Not-To-Exceed (NTE) displacement and KG values, when applicable; a requirement for adjudicating the weight and moment effect of contract changes; a requirement that GFM growth is to be agreed upon before the inclining experiment; an explanation of the contractor-responsible condition; the method of incorporating changes that are proposed solely to achieve satisfactory naval architectural characteristics; and the amount of liquidated damages that apply.

S3.3.2.9 *Design Notebook*—The design notebook shall include a completed set of weight data collection sheets. For each system, these sheets describe the composition of the system, the source of the mass properties data, the latitudes in the system definition that could cause weight variations, the parameters and assumptions that were used to generate the mass properties data, and the concurrence of the cognizant Navy technical code. In addition to the weight data collection sheets, the design notebook shall include a record of the information that was used in the development of the estimates

**USS SAMPLE WEIGHT AND C.G. DESIGN MARGIN STATUS
PRELIMINARY/CONTRACT DESIGN - INTERIM REPORT**

A. WEIGHT:

<u>Item</u>	<u>Contract Design Baseline 10/7/88</u>	<u>Last Report 12/2/88</u>	<u>Current Report</u>	<u>Change From BL</u>	<u>Change From Last Report</u>
1. GROUPS 1-7	6084.9	6123.1	6148.4	(+) 63.5	(+) 25.3
2. a. P.D. Margin	0.0	0.0	0.0	0.0	0.0
b. C.D. Margin	76.9	46.4	35.6	(-) 41.3	(-) 10.8
3. D & B Margins	392.1	392.1	392.1	0.0	0.0
4. Loads	1874.4	1870.9	1839.2	(-) 35.2	(-) 31.7
<hr/>					
5. Projected Delivery	8428.3	8432.5	8415.3	(-) 13.0	(-) 17.2

6. Limits:

Speed	9400
Strength	9370
Subdivision	9426
"V" Lines	9500

SERVICE LIFE DISPLACEMENT ALLOWANCE:

7. Required	841
8. Available at Projected Delivery	955

B. CENTER OF GRAVITY - CURRENT STATUS:

	<u>KG</u>	<u>List</u>	<u>Trim</u>
1. GROUPS 1-7	26.26		
2. a. P.D. Margin	0.00	2.95° (P)	0.33' (A)
b. C.D. Margin	0.28		
3. D & B Margins	1.00		
4. Projected Delivery (Light Ship)	27.54		
5. Projected Delivery (Full Load)	23.96	0.37° (P)	0.77' (A)

LIMITS:

<u>ALLOWABLE KG</u>	<u>LIST</u>	<u>TRIM</u>
25.32	0.50° P/S	1.5'(A)/0.5'(F)

SERVICE LIFE KG ALLOWANCE:

6. Required	1.00
7. Available at Projected Delivery	1.36

Note: Inch-pound units are shown in example, however SI units are applicable when specified.

FIG. S3.6 Example of Interim Report Format (page 1)

USS SAMPLE WEIGHT AND C.G. DESIGN MARGIN STATUS
PRELIMINARY/CONTRACT DESIGN - INTERIM REPORT

<u>Weight Group</u>	<u>Contract Design Baseline 10/7/88</u>	<u>Last Report 12/2/88</u>	<u>Current Report</u>	<u>Change From BL</u>	<u>Change From Last Report</u>
1. Structure	2936.2	2932.5	2941.1	(+)4.9	(+)8.6
2. Propulsion	717.0	705.7	704.8	(-)12.2	(-)0.9
3. Elec. Plant	392.1	393.9	401.8	(+)9.7	(+)7.9
4. Command/Surv.	384.9	381.7	381.7	(-)3.2	---
5. Aux. Systems	799.9	826.7	810.8	(+)10.9	(-)15.9
6. Outfit & Furn.	554.4	583.8	609.4	(+)55.0	(+)25.6
7. <u>Armament</u>	<u>300.4</u>	<u>298.8</u>	<u>298.9</u>	<u>(-)1.5</u>	<u>(+)0.1</u>
Total Groups 1 thru 7:	6084.9	6123.1	6148.4	(+)63.5	(+)25.3

COMMENTS:

Note: Inch-pound units are shown in example, however SI units are applicable when specified.

FIG. S3.7 Example of Interim Report Format (page 2)

and reports. This information typically consists of engineers' notes, memoranda, records of telephone conversations, margin determination/rationale, interim reports, material equipment lists, and an index of drawings, sketches, and reports that were translated into mass properties data. Separate notebooks are required for preliminary design and contract design.

S3.3.2.10 *Electronic Media*—Electronic media shall be provided that describe the final Preliminary or Contract Design Weight Estimate in the format specified in the Annex and in accordance with the requirements set forth in ANSI X3.4.

S3.3.2.11 *Design History*—The design history is a combination of narrative and tabular data that summarizes in chronological order the mass properties evolution of the ship design. The text highlights the major problem areas and their resolutions during the design phase, significant issues and decisions that had an impact on mass properties, and a discussion of margin usage. The narrative is interspersed with summary data from the weight estimates and reports. Separate histories are required for preliminary design and contract design.

S3.3.3 *Pre-Award Process*—This process is the period between the release of the request for proposals (RFP) or request for bids and the award of the contract. Estimates and supplemental documents required during this process shall be in accordance with S3.3.3.1 through S3.3.3.2, as applicable.

S3.3.3.1 *Weight Estimates*—The BIWE or the PABWE is prepared during this process. The estimate shall contain detailed information appropriate to the design phase and loading conditions for light ship and full load and shall be summarized in tabular form as follows:

- (a) Three-digit system number and title.
- (b) Current weight.
- (c) Current vertical lever.
- (d) Current vertical moment.
- (e) Current longitudinal lever.
- (f) Current longitudinal moment.
- (g) Current transverse lever.
- (h) Current transverse moment.

When a technical evaluation is conducted during source selection, the estimate is reviewed for appropriate content and scored against the requirements. After contract award, the successful bidder's, or offeror's, estimate becomes the basis for the AWE or ABWE.

S3.3.3.2 *Bidder's Independent Weight Estimate (BIWE)*—The BIWE establishes the potential contractor's estimate of the ship design before contract award. It is based on the contract, ship specifications, all of the documents referenced therein, the factors for determining loads, and the weights for GFM. The BIWE shall conform to the content and format requirements of S3.3.3.1, include estimated values for design and building margin, and contain loading conditions for light ship and full load. The variable loads shall be realistically distributed throughout the ship in their appropriate spaces. The bidder, or offer, shall include in appendices the following information:

- (a) Historical backup data for estimating factors that were used in the development of the BIWE, such as mill tolerance, paint, weld material, insulation, and so forth.
- (b) The technical analysis that substantiates the values

selected for design and building margin.

(c) A summary of GFM as reported in the details of the BIWE (see S3.3.3.1).

When NTE displacement and KG values are defined in the contract, the bidder, or offeror, shall take the appropriate measures to reflect the design solutions and building practices that ensure delivery of a satisfactory ship.

S3.3.3.3 *Preliminary Allocated Baseline Weight Estimate (PABWE)*—The PABWE establishes the potential contractor's estimate of the ship design before the award of a performance-type contract. It is based on the contract, Circular of Requirements, all the documents referenced therein, and the bidder's, or offeror's, proposed hull and propulsion configurations. The report shall conform to the requirements of S3.3.3.1, include estimated values for design and building margin, and contain contract modification and GFM margins as specified. Variable loads shall be realistically distributed throughout the ship in their appropriate spaces. The bidder, or offeror, shall include in appendices the following information:

(a) Historical backup data for estimating factors that were used in the development of the PABWE, such as mill tolerance, paint, weld material, insulation, and so forth.

(b) The technical analysis that substantiates the values proposed for design and building margin.

(c) A summary of GFM as reported in the details of the PABWE (see S3.3.4.3).

After contract award, the PABWE of the successful bidder, or offeror, becomes the basis for the ABWE, which is used to measure contractor responsibility.

S3.3.3.4 *Supplemental Documents*—The supplemental documents specified in S3.3.3.5 and S3.3.3.6 provide additional information and background data required during the pre-award process.

S3.3.3.5 *Preliminary Weight Control Plan*—A preliminary weight control plan shall be submitted with detail design and construction proposals that outlines the procedures that shall be followed to meet contractual weight control responsibilities. The plan shall include, but is not limited to, the following topics:

(a) A discussion of design risk with respect to the ship's naval architectural characteristics, including special weight control problems and the areas that will receive weight control emphasis.

(b) A discussion of the method to be used in adjusting margin accounts.

(c) The frequency of briefings to top management concerning the ship's naval architectural condition throughout the detail design and construction phase. The individual who will give the briefings shall be identified.

(d) A description of the computer systems, both hardware and software, that will be used in the weight control effort.

(e) A listing of equipment that will be used to perform actual weight measurements. The listing shall include equipment capacity, accuracy tolerance, and calibration frequency.

(f) A discussion that conveys an understanding of the actual weight determination requirements of the contract.

(g) A discussion of the detail to which the ship construction drawings will be calculated and the recommended selected

areas of the estimates and reports that will be scheduled for timely calculations during the design phase of the contract.

(h) The reporting schedule and cutoff dates for weight calculations.

(i) The planned action for verification of mill tolerances, welding, and paint factors.

(j) The management and technical authority of the weight control coordinator relative to the overall design effort anticipated.

(k) The method of communicating the condition of the ship to line personnel.

(l) The management actions that will be taken upon detection of weight and margin trends tending to cause contractual values to be exceeded.

(m) The method and degree of weight control that will be required of subcontractors and vendors.

(n) A discussion of construction monitoring techniques that will be used to ensure that the ship, as constructed, is accurately reflected in the weight reports.

(o) A discussion of weight control training to be administered to personnel involved in the design and construction of the ship.

S3.3.3.6 Resumes—Resumes of weight control personnel that will be directly involved with the ship weight control program shall be submitted with the proposal.

S3.3.4 Detail Design and Construction Phase—Weight estimates, reports, and supplemental documents prepared during this phase shall be in accordance with the requirements specified in S3.3.4.1 through S3.3.5.8. When the mass properties data for two or more ships under the same contract are identical, the estimates, reports, and supplemental documents can apply to more than one hull number. If deviations in design or construction create unique mass properties data, then separate summaries and condition sheets shall be included with QWRs and separate FWRs shall be submitted. The contractor and NAVSEA shall agree on selected areas of estimates and reports that will be scheduled for timely calculation during detail design and shall agree on the procedure for reviewing appropriate drawings. These areas and the review process shall be agreed on before, or concurrently with, establishing the AWE/ABWE.

S3.3.4.1 Weight Estimates and Reports—Weight estimates and reports prepared during this phase consist of the ABWE or AWE, QWR, and FWR. These estimates and reports shall contain detailed information appropriate to the status of the design at the time of submittal and loading conditions as described in S3.1.1, and shall be summarized in tabular form as follows:

- (a) Three-digit system number and title.
- (b) Original weight (not required for AWE or ABWE).
- (c) Current weight.
- (d) Current vertical lever.
- (e) Current vertical moment.
- (f) Current longitudinal lever.
- (g) Current longitudinal moment.
- (h) Current transverse lever.
- (i) Current transverse moment.

(j) Current percent completion (not required for AWE or ABWE).

(k) Special coding symbols.

S3.3.4.2 Every item that comprises the completed ship shall be included in the weight estimates and reports and grouped in accordance with the three-digit system. For the data to be useful in a variety of applications, the details shall contain an accurate description that links each listed item to a recognizable component. For example, a long listing of plates, tees, angles, beams, chocks, and so forth, with precise weight and center of gravity data, does not comprise a satisfactory estimate, unless those pieces of structure can be readily identified with a specific bulkhead, deck, foundation, or other structure. Similarly, the descriptions for distributive systems shall indicate the major components that are being connected. Component descriptions shall include identifiers, such as type, size, rating, capacity, and so forth. An example of adequate detail and proper numerical ordering is shown in Fig. S2.1. Calculations and actual weight determinations shall be terminated in advance of report preparation to ensure timely submittals.

S3.3.4.3 Determination of Mass Properties Data—Mass properties data may be obtained by a combination of estimation or calculation of ship construction drawings and actual weight determination. The actual weight of all components and equipment, greater than 500 lbs or 225 kg (unless otherwise specified), both contractor and government-furnished, shall be determined through accurate scale weighing along with the estimation or calculation of centers of gravity. The actual weights for materials, components, and equipment, less than 500 lbs or 225 kg, shall be determined on a selective or sampling basis, as determined by the contractor, to provide unit weight data. Potential candidates for actual weight determination on a selective basis include such items as insulation, structural plates and shapes, sheathing, piping, and the components and equipment less than 500 lbs or 225 kg. Where factors or percentages are used, such as for estimating and calculating paint, mill tolerance, and welding, the contractor shall substantiate these values by supplying background information (current and historical). Historical background information on paint, mill tolerance, and welding factors shall be forwarded with the BIWE or PABWE. Final values for paint, mill tolerance, and welding factors, based on current ship information, shall be forwarded with the FWR. Also, when design development has occurred for a component, system, or portion of structure, a reevaluation of the original weight estimate shall be made to obtain the most accurate current weight. In addition, to minimize the amount of actual weight determination at the shipbuilding site, the contractor shall require, through acquisition documents, subcontractors or vendors to submit information on the current weight and center of gravity of all major assemblies, equipment, fittings, or components to be installed on the ship. It is suggested that information be submitted by subcontractors or vendors in the following sequence:

- (a) An estimate of weight and center of gravity in the proposal.
- (b) The calculated weight and center of gravity when the design is completed.

(c) The actual weight and calculated center of gravity when the fabrication or assembly is completed.

S3.3.4.4 Accepted Weight Estimate (AWE)—After contract award, the contractor and NAVSEA shall agree on AWE values for displacement and KG. To expedite this agreement, the contractor shall, upon request, visit NAVSEA not less than one month before the required submittal date of the AWE. The estimate shall consist of the contractor's BIWE that was submitted during the solicitation process, adjusted as necessary to reflect corrections and negotiated changes, such as reclassification of data. The AWE shall include loading conditions, summaries, supporting details for each three-digit element, appropriate margins, and an appendix that establishes the baseline for measuring detail design changes in GFM. The estimate shall conform to the content and format requirements of S3.3.4.1.

S3.3.4.5 Allocated Baseline Weight Estimate (ABWE)—The ABWE establishes the contractor's estimate of the ship design when the hull and propulsion configurations are defined. The ABWE shall reflect a design that meets all of the required performance criteria, satisfies the required service-life allowances, and includes the appropriate margins. The basis for the estimate shall be the contractor's PABWE that was submitted during the solicitation process, adjusted as necessary to reflect design changes and corrections. The ABWE shall include loading conditions, summaries, margins, and an appendix that establishes the baseline for measuring detail design changes in GFM. The estimate shall conform to the content and format requirements of S3.3.4.1.

S3.3.4.6 Quarterly Weight Reports (QWR)—The QWR shall document the current mass properties status of the ship design and construction effort. The light ship and full-load conditions shall reflect the ship that is projected for delivery, including the current mass properties values for GFM and contract modifications, both adjudicated and unadjudicated. The contractor-responsible condition shall be used to adjust the current full load to account for changes that occur after the establishment of the contractual baseline and are not within the control of the shipbuilder. Examples of these types of changes are as follows:

- (a) Changes in weight of GFM and the moment changes associated with those weight changes.
- (b) The net effect of contract modifications.
- (c) Changes in weight of equipment designated as standard for the class and the moment changes associated with those weight changes.
- (d) Changes that result from the required use of warranted documentation.
- (e) Growth resulting from directed acquisitions.

S3.3.4.7 Separate summaries for each type of change previously listed shall be provided as appendices to the QWR. A GFM summary (see S3.3.4.3) and a contract modification summary (see S3.3.4.17) are required with every submittal of a QWR. Other summaries may be submitted at the option of the contractor to substantiate growth beyond his control. If an optional summary is submitted, it shall document all of the activity for that particular type of change, weight increases and decreases, and modified locations. The ship's displacement,

KG, list, and trim from the contractor-responsible condition shall be compared to the AWE or ABWE values for displacement and KG and the specified allowable ranges for list and trim. Report details shall be grouped in accordance with the three-digit system, and each item shall indicate whether the information shown is estimated, calculated, or based on actual weight determination. The report shall conform to the content and format requirements of S3.3.4.1. In addition, the report shall contain reasons for changes, recommendations to correct any adverse trends, and a listing of all the equipment for which an actual weight determination was performed during the reporting period.

S3.3.4.8 Final Weight Report (FWR)—The FWR shall reflect the final status of the ship design and construction effort that resulted in a delivered product and is normally based on an inclining experiment. All of the reporting requirements of a QWR (see S3.3.4.6) also apply to a FWR. In addition, when inclining experiment full-load displacement and KG values differ from the weight estimate without margin predictions by greater than ½ %, an analysis of the data shall be conducted to reconcile the differences. Findings that result in correction of inaccuracies, reevaluation of factors, and so forth, shall be incorporated in the FWR. The only acquisition margin that may appear in the FWR is building margin. This margin accounts for irreconcilable differences between the weight report and the inclining experiment. The FWR shall contain a narrative that describes the portions of the weight data that are still based on factors, such as paint, weld material, mill tolerance, and so forth, and the criteria that comprise the factors.

S3.3.4.9 Weight Estimate and Report Appendices—The following appendices specified in S3.3.4.10 through S3.3.4.17 provide additional information and background data during the detail design phase.

S3.3.4.10 GFM Summary—The purpose of the GFM summary is to extract from the estimates and reports weight and location data for all GFM and identify the government responsible net weight and moment change that occurs to GFM during detail design. The GFM summaries shall accurately reflect the Schedule A portion of the contract, conform to the content and format requirements of S3.3.4.16, and be included as an appendix to the BIWE or PABWE, AWE or ABWE, each QWR, and the FWR. The baseline for measuring detail design changes is established in the AWE or ABWE. Once accepted, the baseline is only revised when acquisition responsibility is transferred or to correct data that was available to the contractor before the AWE or ABWE, but was inaccurately reported. Weight changes to GFM and the moment changes associated with those weight changes, along with contract modifications and other types of changes beyond the control of the shipbuilder, are deducted from the current full-load condition to arrive at the contractor-responsible condition. Changes to GFM can result from better definition of the baseline items as the design matures; the addition, deletion, or modification of items by a revision to Schedule A; or a transfer of acquisition responsibility.

S3.3.4.11 Adjustment to Baseline GFM—The weight and moment totals from the GFM summary in the AWE or ABWE shall be the basis for measuring all subsequent GFM changes

and shall be known as the baseline values. In cases in which inaccuracies are discovered in the baseline values for which correct data was available to the contractor before submittal of the AWE or ABWE, the weight report details shall be modified to reflect the correct information. In the GFM summary, the baseline values shall be adjusted and the weight and moment effect of the adjustment becomes the responsibility of the contractor. Fig. S3.8 provides a typical example of the accounting procedure for this type of change.

S3.3.4.12 Design Development to Baseline GFM—When design development occurs to items of baseline GFM, the weight report details shall be updated to record current weight and moment data. The contractor is responsible for properly locating the items of GFM throughout detail design. Moment changes resulting from the relocation of GFM to suit design development are not allowable deductions when determining the contractor-responsible condition. The government is responsible for the weight and moment impact of weight changes to baseline items that occur after the establishment of the baseline. An acceptable method of computing government-responsible moment changes is to multiply the net weight change of baseline GFM design development by the centers of gravity from the original or adjusted baseline GFM. These net weight and moment changes are then deducted from the current full-load condition when determining the contractor-responsible condition. Additionally, once a contract modification has been adjudicated, the GFM portion of the change shall be incorporated into a second section of the GFM summary (conforming to the content and format requirements of S3.3.4.16, with the GFM weight and moment values included as adjudicated in the baseline weight column and in the current values. This section will be used to monitor weight changes to GFM after the contract modification has been adjudicated. Any weight and moment changes identified in GFM after adjudication shall be reflected in the current weight column and included with the weight and moment changes that are deducted from the current full-load condition when determining the contractor-responsible condition.

S3.3.4.13 Revision to Schedule A—When Schedule A is revised to add, delete, or modify GFM, the weight report shall be updated accordingly and the changes shall be reflected as current values in the GFM summary. Since these types of changes will usually be implemented by a contract modification, the contractor shall ensure that the weight and moment changes are also reflected in the contract modification summary. However, for the purpose of determining contractor responsibility, the weight and moment impact of contract modifications on GFM before adjudication should not be included with the GFM net changes, since it is already included with the net effect of contract modifications. Any changes in GFM included with contract modifications after adjudication are covered in S3.3.4.12.

S3.3.4.14 Acquisition Responsibility Changes from Government to Contractor—When acquisition responsibility passes from the government to the contractor, the current values and the baseline values for the item shall be deleted from the GFM summary. If the current weight differs from the baseline weight, the contract modification shall reflect the weight

difference. Moment changes associated with the weight difference may be computed by using the baseline centers of gravity for the item that was transferred. After the modification has been adjudicated, changes in weight and location are the responsibility of the contractor.

S3.3.4.15 Acquisition Responsibility Changes from Contractor to Government—When acquisition responsibility passes from the contractor to the government, current weight and moment values for the item that appear in the most recently submitted weight report shall be added to the baseline weight and current weight columns of the GFM summary. Contract modifications that cause this type of transfer shall reflect no weight or moment change. Any subsequent weight change shall be treated as routine design development of GFM and becomes the responsibility of the government.

S3.3.4.16 GFM Summary Format—The GFM summary shall be in tabular form with subtotals by the three-digit system, grand totals for current values, and shall include columns containing the following information for each item:

- (a) Three-digit system number.
- (b) Schedule A item number.
- (c) Description of the item.
- (d) Baseline weight.
- (e) Current estimated, calculated, or actual weight.
- (f) Current vertical lever.
- (g) Current vertical moment.
- (h) Current longitudinal lever.
- (i) Current longitudinal moment.
- (j) Current transverse lever.
- (k) Current transverse moment.

S3.3.4.17 Contract Modification Summary—Before each claim for equitable adjustment in price or delivery or both, asserted pursuant to the changes clause of the contract, an estimate of the net weight and moment change resulting from the contract modification shall be prepared and submitted to the supervisor. The contract modification summary shall reflect these weight and moment impacts as they appear in the details of the weight estimate, for both adjudicated and unadjudicated changes, including field changes. The summary shall consist of all approved changes listed numerically by NAVSEA number and shall include the title, net weight, and moment impact of each change; an identifier that indicates whether the data is adjudicated or unadjudicated; and a grand total representing the net effect of all approved contract modifications. The contract modification summary shall be submitted as an appendix to the QWRs, the ASR, and the FWR. Supporting details for each contract modification shall be incorporated into the body of the weight estimate as soon as the change is approved. Before adjudication of the contract modification, the weight and moment effect of the change as reported in the contract modification summary shall reflect the current values of the supporting details. After the contract modification has been adjudicated, the supporting details are treated as any other line items in the weight estimate, but the weight and moment effect of the change as reported in the contract modification summary remains at the adjudicated values. The weight and moment impact of the addition, deletion, or modification of GFM to the

GFM SUMMARY TOTALS

	Weight	VCG	V. Moment	LCG	L. Moment	TCG	TM
Original Baseline Values from AWE/ABWE	355.00	31.22	11083	157.35A	55859	0.17P	60
Adjustments to Original Values (+/-)	+ 2.25	45.72	117	292.08A	515	9.27S	-24
New Basis for Measuring GFM Changes	357.25	31.35	11200	157.80A	56374	0.10P	36
Current Values from Quarterly #	363.50	31.17	11330	157.25A	57160	0.12P	44
Government-Responsible Change to GFM	+ 6.25	20.80	130	125.76A	786	1.28P	8

Note: Inch-pound units are shown in example, however SI units are applicable when specified.

FIG. S3.8 Example of GFM Summary Format

Schedule A is implemented by a contract modification summary. If acquisition responsibility passes from the government to the contractor, the contract modification summary shall reflect any difference in weight between the current and baseline weight values. Moment changes associated with the weight difference may be computed by using the baseline centers of gravity for the item that was transferred. Changes in weight are the responsibility of the contractor after the contract modification has been adjudicated. Contract modifications that change acquisition responsibility from the contractor to the government shall reflect no weight or moment impact in the contract modification summary.

S3.3.4.18 Supplemental Weight Report—The following supplemental weight report, specified in S3.3.4.19, provides additional information and background data during the detail design phase.

S3.3.4.19 Machinery Weight Report (Nuclear)—A machinery weight report for a nuclear ship design shall be submitted in the category system in accordance with NAVSEA 0900-LP-039-9020. The report shall be divided into two sections. Section I shall contain nuclear machinery items; Section II shall contain the remaining items of the category system. The following summary sheets shall be included:

(a) A listing of a total for each three-digit group within each of the Categories A through M (excluding I). Subtotals shall be listed for each category and a grand total for nuclear propulsion machinery.

(b) Same as (a), except that Sections I and II shall be listed separately with a subtotal for each section, and a grand total for nuclear propulsion machinery.

(c) A listing of a total of Categories A through M (excluding I) for each three-digit group to make a grand total for nuclear propulsion machinery.

The totals for all summaries shall be the same.

S3.3.4.20 Machinery Weight Report Format—The report shall include the following information in tabular form:

(a) Original weight values from the AWE or ABWE for each item.

(b) Current weight of each item.

(c) Current vertical levers.

(d) Current vertical moments.

(e) Current longitudinal levers.

(f) Current longitudinal moments.

(g) Current transverse levers.

(h) Current transverse moments.

When this report is submitted concurrently with the AWE or ABWE, the QWR, and the FWR, it shall reflect the details of the report it accompanies.

S3.3.5 Supplemental Documents—The following supplemental documents when required by the CDRL, provide additional information and background data during the detail design and construction phase.

S3.3.5.1 Weight Control Plan—A weight control plan shall be submitted that outlines the procedures to be followed in meeting the contractual weight control responsibilities. The plan shall address, but is not limited to, the topics listed in S3.3.3.5. In the event a preliminary weight control plan was submitted during the solicitation process, the post-award plan

described herein shall not differ from the preliminary plan in basic content, intent, or significance.

S3.3.5.2 Accepted Ship Report (ASR)—The ASR is the document that demonstrates the contractor's performance with regard to weight control. It constructs contractor responsibility by reporting the light ship values for displacement, KG, trim, and list from the inclining experiment, and the current loads from the most recent QWR. The net weight and moment effect of the following categories of changes are then algebraically subtracted:

(a) Adjudicated and unadjudicated contract modifications that were included in the inclining experiment data.

(b) Other directed modifications to loads.

(c) Modifications to GFM since the AWE.

(d) Other allowable categories (see S3.3.4.6).

S3.3.5.3 The results are then compared to the corresponding values in the AWE. The report shall be submitted in summary form similar to the example formats shown in Fig. S3.9, as required by the CDRL. The procedure to compute contractor responsibility for performance-type contracts shall be submitted in summary form similar to the example format shown in Fig. S3.10, as required by the CDRL. If the final inclining experiment data differ significantly from the preliminary report of the inclining, or if they would alter the conclusions drawn from the ASR, the report shall be corrected by the contractor to reflect these differences and resubmitted.

S3.3.5.4 Design and Weight Data Sheet—The design and weight data sheet shall contain the information and be of the format indicated in Fig. S3.11, which is an example for a gas-turbine-powered ship. Major load and machinery items, as appropriate to the applicable ship, shall be listed. This document shall be submitted with a note indicating whether the units are in the SI or inch-pound system.

S3.3.5.5 Weight Moment of Inertia Report—A weight moment of inertia report shall be submitted for the full-load condition. Current weights, centers of gravity, and engineering information describing the shape and orientation of each data element shall be used to develop weight moments of inertia. The minimum required data shall be tabulated as follows:

(a) Ship-oriented roll, pitch, and yaw weight moments of inertia about the ship's centroid in the full-load condition and each individual data element's centroidal axes summarized by the three-digit system.

(b) Ship-oriented roll, pitch, and yaw weight moment of inertia about the ship's centroid in the full-load condition and each individual data element's centroidal axes summarized by group.

(c) Ship-oriented roll, pitch, and yaw weight moments of inertia about the ship's centroid in the full-load condition and each individual data element's centroidal axes for the total ship.

(d) The gyradius for roll, pitch, and yaw.

S3.3.5.6 Weight Distribution Report—A longitudinal weight distribution shall be submitted in a tabulated format in accordance with the standard longitudinal station breakdown. Weight and longitudinal center of gravity shall be determined for each ship station for both light ship and full-load condition. The resultant total weight and longitudinal center of gravity for

EXAMPLE

ACCEPTED SHIP REPORT

	WEIGHT	KG	VERTICAL MOMENTS	LCG	LONGITUDINAL MOMENTS	TCG	TRANSVERSE MOMENTS	TRIM (F) / (A)	LIST (P) / (S)
Inclining Experiment (Condition A)									
Current Loads from latest QWR (add)									
Current Full Load (Total)									
Net Effect of Contract Mods (Deduct) (note 1)									
Directed Modifications to Loads (Deduct)									
GFM Net Changes (Deduct) (note 2)									
Other Allowable Adjustments (note 3)									
Contractor Responsible Values (Total)									
Accepted Weight Estimate Values								(note 4)	(note 4)

NOTES:

1. Represents summation of adjudicated and unadjudicated values for all contract modifications that were included in the inclining experiment data (including those affecting variable loads).
2. Represents values for net weight and moment changes in GFM since the AWE.
3. These adjustments can include equipment designated as standard for the class changes, changes resulting from the required use of warranted documentation, or growth resulting from directed procurements.
4. Insert tolerances agreed to or limits in Section 070 of the Ship Specifications.

EXAMPLE

FIG. S3.9 Example of Accepted Ship Report Format

ACCEPTED SHIP REPORT
(Performance-type contract)

EXAMPLE

	WEIGHT	KG	VERTICAL MOMENTS	LCG	LONGITUDINAL MOMENTS	TCG	TRANSVERSE MOMENTS	TRIM (F) / (A)	LIST (P) / (S)
Inclining Experiment (Condition A)									
Current Loads from latest QWR (add)									
Current Full Load (Total)									
Government Margins									
Contract Modifications Remaining (Add) Exceeded (Deduct)									
GFM Remaining (Add) Exceeded (Deduct)									
Contractor Responsible Values (Total)									
ABWE/AWE Values								(note 1)	(note 1)
Governing NA Limit									
Available Service Life Allowance									
Required Service Life Allowance									

NOTE: 1. Insert tolerances agreed to or limits in Section O70 of the Ship Specifications.

FIG. S3.10 Example of Accepted Ship Report Format

EXAMPLE

the weight distribution report shall equal the values reflected in the basic weight estimate or report for the same reporting period.

S3.3.5.7 *Electronic Media*—Electronic media shall be submitted that describes the FWR in the format specified in the Annex and in accordance with the requirements set forth in ANSI X3.4.

S3.3.5.8 *Weight and Moment Trade-Off Studies*—Trade-off studies comprise various engineering and technical studies directed toward determining detail weight data. These analytical studies are used to support design change proposals and support recommendations for reversing trends toward exceeding established margins or limits. These studies are conducted on an “as requested” basis and contain detailed weight calculations reflecting the impact of the study on ship displacement, KG, list, and trim. There is no fixed format for the weight calculations, but each submittal shall use the ESWBS classification system to structure and summarize the data.

S4. NOTES

S4.1 *Issue of DODISS*—When this guide is used in acquisition, the applicable issue of the DODISS must be cited in the solicitation (see S1.1 and S1.2).

S4.2 *Data Requirements*—The following Data Item Descriptions (DIDs) must be listed, as applicable, on the Contract Data Requirements List (DD Form 1423) when this guide is applied on a contract to obtain the data, except when DOD

FAR Supplement 27.475-1 exempts the requirement for a DD Form 1423.

Reference Paragraph	DID Number	DID Title	Suggested Tailoring
S3.3.1 through S3.3.2.3, S3.3.2.7, S3.3.2.9 through S3.3.2.11, S3.3.3 through S3.3.3.6, S3.3.4 through S3.3.5.8, Figs. S2.1-A1.2, and Annex A1, including Fig. A1.1	DI-MISC-81357	Mass properties data report (surface ships)	...
S3.3.2.6	DI-A-23434	List, contract data requirements (DD Form 1423)	...

S4.2.1 The preceding DIDs were those cleared as of the date of this guide. The current issue of DOD 5010.12-L, Acquisition Management Systems and Data Requirements Control List (AMSDL), must be researched to ensure that only current, cleared DIDs are cited on the DD Form 1423.

S4.3 *Reports Interface*—The interface of weight estimates and reports is depicted in Fig. S3.11.

S4.4 This guide satisfies a requirement to combine all weight control technical requirements for all phases of U.S. Navy surface ship acquisition contracts into a single document.

ANNEX

(Mandatory Information)

A1. INPUT DATA FILE FORMAT AND TRANSFER

A1. Scope

A1.1 *Scope*—This annex contains the required format for completing the standard Navy weight report input data files. This annex is a mandatory part of this guide. The information contained herein is intended for compliance (see S4.2).

A1.2 *Format*—Input data files, when required by the design contract or ship specifications, shall be in accordance with the format specified in Annex A1. In general, for each item in the weight estimate there shall be two lines of data in the file. The first line is mandatory and shall contain information regarding the weight and center of gravity of the item. The second line is optional, depending upon the specification requirements, and shall contain information regarding the inertia characteristics of the item. An example of the Navy standard weight estimate format is shown in Fig. A1.1.

A1.2.1 *First Line of Data*—The format for the first line of data is as follows:

A1.2.1.1 *Columns 1 through 5, Classification Number*—Columns 1 through 3 are based on the Expanded Ship Work Breakdown Structure (ESWBS) (see NAVSEA S9040-AA-IDX-010/SWBS 5D). Columns 4 and 5 provide for special subtotals within the classification number. Columns 4 and 5

shall contain only numeric data. Generally, two zeroes are used to designate an ESWBS element title. For example, Main Deck would be designated 13100 for ESWBS. Note that ESWBS subgroups ending in a zero are not to be used for input data, such as 110, 120, 230, 240, and so forth.

A1.2.1.2 *Column 6*—Column 6 is used for functional category designation when required for nuclear-powered ships. These categories are defined by NAVSEA 0900-LP-039-9020.

A1.2.1.3 *Columns 7 through 10, Item Number*—The item number provides the means of identification of each line within any five-digit element number. The following rules apply:

- (a) Each line shall have an item number.
- (b) All titles representing any of the basic ESWBS titles shall include a zero in Column 10.

NOTE A1.1—Titles for special subtotals within an ESWBS element may contain any item number desired.

- (c) Care shall be taken not to repeat any item numbers within a five-digit element.
- (d) Do not use any leading zeroes in the item number, such as 0010.
- (e) Item numbers for entries should be entered in increments of ten, such as 10, 20, and 30, instead of 1, 2, and 3.
- (f) All item numbers shall be right justified.

A1.2.1.4 *Column 11, Station*—This column is used in conjunction with the standard longitudinal weight distribution for subsequent strength calculations. For weight distribution, the ship is divided into 22 stations which are lettered A through X (excluding I and O). Station A is designated to contain all items whose longitudinal center of gravity (LCG) is forward of the forward perpendicular. Station B contains all items with an LCG between the forward perpendicular and ship Station 1. Station C contains items between ship Station 1 and ship Station 2, and so on to Station X, which contains all items aft of the aft perpendicular. For each item (except titles and items with no weight), Column 11 shall contain a letter from A through X (excluding I and O), unless one of the following special options is used:

(a) An asterisk inserted in Column 11 for any item indicates the weight will be automatically distributed in a 22-station longitudinal distribution in proportion to the basic hull structure. The basic hull structure for ESWBS consists of Group 1 from 110 through 159, except 114 and 123 through 126. Items in the basic hull structure shall not use the asterisk option.

(b) A digit of 2 through 9 in Column 11 indicates the weight for the given item will be distributed over 2 through 9 stations centered about the item's LCG. If enough stations are not available to do a particular distribution, the distribution will be done over as many stations as are available. For instance, if a six-station distribution is required within two stations of either end of the ship, then a four-station distribution will occur.

A1.2.1.5 *Column 12, Special Designator*—This column shall contain designators established by the government. Where no designator is applicable, this column shall be left blank. In the event of a conflict in determining which designation is to be used, the order of precedence shall be by alphabetical order. This designator provides for dual purpose as follows:

(a) Provides for extractions across the entire ship for summaries, such as plates, extruded shapes, weldments, primary, secondary, and others as required.

(b) Provides for listing within the three-digit element, such as controls, components, distribution, and others as required.

(c) The following designators are applicable:

- C – Controls, such as valves, switches, regulators, gear boxes, and shutters.
- D – Distribution items, such as ducts, pipe, wire, wireways, connectors, waveguides, propeller shafts, and propeller shaft bearings.
- E – Plating and sheeting.
- F – Forgings, extruded shapes, rolled shapes, built-up shapes, and castings.
- G – Weldments.
- M – Major components, such as air conditioner units, antennas, actuators, batteries, blowers, boilers, compressors, computers, cranes, davits, distillers, transmitters, receivers, transceivers, engines, fans, generators, motors, propellers, pumps, turbines, winches, and replenishment-at-sea (RAS) equipment.
- P – Secondary, peripheral, and interface components, such as hydraulic reservoirs, electrical power supplies, nonintegral tanks, filters, heat exchangers (for system), and subbases.

A1.2.1.6 *Column 13, Special Modifier*—This column shall contain a modifier established by the government for the Column 12 designator for those items in Groups 1 through 7 only, that is, not including items of variable load. In the event a modifier cannot be determined, a Z shall be inserted. This modifier provides for dual purpose as follows:

(a) Provides for extractions across the entire ship for various

material types, such as all steel, all aluminum, and others as required.

(b) Provides for special systems summaries across the entire ship or within certain elements, such as all payload, all habitability, and special systems such as hydrofoils and air cushions.

(c) The following modifiers are applicable:

- A – Aluminum.
- B – Brass and bronze.
- C – Copper, copper-nickel, and nickel-copper.
- D – Ordinary strength steel.
- E – Higher strength steel.
- F – Fiberglass, plastic, and insulation material.
- H – Habitability items, such as berthings, clothing and personal effects stowage, leisure systems, sanitary systems, messing, personal service, utility, and work systems. (This modifier shall supersede any material-type modifiers.)
- J – Wood material.
- K – Liquids.
- L – Lead.
- M – Miscellaneous metallic material.
- N – Miscellaneous nonmetallic material.
- P – Payload, which includes items that are peculiar to the specific missions of a particular ship, such as minesweep gear on a minesweeper, oceanographic gear on an oceanographic ship, and so forth. (This modifier shall supersede any material modifiers.)
- W – Welding, riveting, and fastening.

A1.2.1.7 *Columns 14 through 45, Description*—These 32 columns shall be used to describe each item adequately. Whatever is entered as input data is reproduced exactly on the weight estimate or report printout. Any combination of alphanumeric characters or blanks can be used. Clear and complete description is essential. However, if budget weights are being used, the description field shall be limited to 24 columns (Columns 14 through 37). Columns 38 through 45 will then be used for budget weights (see A1.2.1.8).

A1.2.1.8 *Columns 38 through 45, Budget Weight*—Budget weight, if used, is entered in pounds on ESWBS titles only. This allows weight values from 0 to 99 999 999 lbs (to be entered 99999999).

A1.2.1.9 *Columns 46 through 53, Unit Weight*—Always enter unit weight of any item in pounds. The broken line on the Standard Navy Transmittal Form (NAVSEA 5230/32) between Columns 51 and 52 provides a decimal point, allowing a unit weight up to 999 999.99 lbs. When the unit weight is a whole number, enter two zeroes behind the implied decimal point. If the weight is a deduction, enter a minus sign (–) immediately before the unit weight number.

A1.2.1.10 *Columns 54 through 57, Number of Units*—Values from 0.001 to 999 units can be entered. This number is multiplied by unit weight to produce total weight for each line item. Unit weight, number of units, and total weight are all printed in the detail output.

A1.2.1.11 *Columns 58 through 62, Vertical Center of Gravity (VCG)*—These columns shall be used for entering the VCG of each item. The VCGs shall be carried out to the hundredth decimal place. When the VCG is a whole number, two zeroes must be entered after the decimal point. If the VCG is negative (a weight below the baseline), enter a minus sign immediately before the VCG number. All VCGs are measured in feet. The VCG will be multiplied by the computed total weight, and the resultant vertical moment will be printed.

A1.2.1.12 *Columns 63 through 67, Longitudinal Center of*

Gravity (LCG)—These columns shall be used for entering the LCG of each item. The LCG is measured in feet and carried out to the hundredth decimal place. Always enter a positive LCG; no sign is necessary. When the LCG is a whole number, enter two zeroes behind the implied decimal point. The LCG will be multiplied by the computed total weight, and the resultant longitudinal moment will be printed.

A1.2.1.13 Column 68, LCG Sign—As previously mentioned, the LCG is always entered as a positive value. Enter “F” or “A” to indicate whether the weight is located forward or aft of the longitudinal reference datum. A blank in Column 68 is interpreted to mean “A” or aft.

A1.2.1.14 Columns 69 through 73, Transverse Center of Gravity (TCG)—These columns shall be used for entering the TCG of each item. The TCGs shall be carried out to the hundredth decimal place. When the TCG is a whole number, two zeroes must be entered after the decimal point. All TCGs are measured in feet port or starboard of the centerline, with the exception when port and starboard symmetry exists. If a line item has port and starboard symmetry, the TCG is measured in feet from the transverse center of one side (port or starboard) of the symmetrical item. This is essential to calculate the weight moment of inertia value of the line item. Always enter a positive TCG; no sign is necessary. If the TCG is not applicable, leave Columns 69 through 73 blank. The TCG will be multiplied by the total weight, and the resultant transverse moment will be printed.

A1.2.1.15 Column 74, TCG Sign—As mentioned previously, the TCG is always entered as a positive value. Enter “P” or “S” to indicate whether the weight is port or starboard of the centerline. However, when a line item has port and starboard symmetry about the centerline, enter “X” to indicate the transverse center of one side (port or starboard) of the symmetrical line item. This distance will only be used to calculate the weight moment of inertia of the line item. A blank in Column 74 is interpreted to mean “P” or port.

A1.2.1.16 Column 75, Reservation Indicator (RES)—This column is used to indicate reservation items or design responsibility. The letter “R” shall be used to designate a reservation item. The letters “A” through “Z” (except “R”) may be used, as required, to indicate design responsibility, such as:

- H – Hull design.
- M – Machinery design.
- E – Electrical design.

A1.2.1.17 Column 76, Reason for Change—This column is used to indicate the reason for change as follows:

- 0 – Nomenclature change (no weight change).
- 1 – Contract modification change.
- 2 – Government-furnished material change.
- 3 – Change to class status, such as estimated to calculated or calculated to actual.
- 4-9 and A-Z user-assigned reasons. The column appears under “CHG” in the output.

A1.2.1.18 Column 77, Material Source Indicator—The column is used to indicate the source of an item as follows:

- G – Government-furnished material.
- F – Contractor-fabricated material.
- P – Contractor-purchased material.

A1.2.1.19 Column 78, Class Status—Used to indicate the

confidence of the weight value entered for the line item as follows:

- E – Estimated weight.
- C – Calculated weight.
- A – Actual (scale) weight.
- V – Vendor or catalog weight (to be changed to “A” upon actual weight determination of the item).

A1.2.1.20 Columns 79 and 80, Report Number—Enter the report number in which the change was first incorporated. Report Number “AO” shall be used for the first submittal of input. Line items changed before the first periodic weight report shall carry Report Number “BO” for the first such change, “CO” for the second, and so forth. The first periodic weight report shall have Column 79 blank, and a “1” in Column 80, and so forth. Deletions may contain the letters “DD” in Columns 79 and 80, instead of a report number, or the deletion line may be erased.

A1.2.2 Second Line of Data—The second line of data for each item contains the gyradius data for the item and immediately must follow the first line of data in the file. The format for the second line of gyradius data is as follows:

A1.2.2.1 Columns 1 through 5, Classification Number—These columns must contain the same five-digit classification number as the line of weight data that precedes it in the file.

A1.2.2.2 Column 6, I_o Designator—An asterisk (*) must be included in this field to designate the line as a second line containing inertia data for the previous line.

A1.2.2.3 Columns 7 through 10, Item Number—These columns must contain the same item number as the preceding line that contains the weight data for the item.

A1.2.2.4 Column 20, Shape of I_o Item—This field is used to indicate what kind of shape is to be used to estimate the I_o for the weight item. The following are shapes that may be used:

- 0 – The I_o calculation is to be the ratio or a percentage of a three-digit element's I_o .
- 1 – The I_o data are actual inertias.
- 2 – Rectangular prism.
- 3 – Hollow frustrum of a cone.
- 4 – Hollow right circular cylinder.
- 5 – Right rectangular pyramid.
- 6 – Hollow hemisphere.
- 7 – Square diamond.

Drawings showing the geometry and orientation of Shapes 2 through 7 can be found in Fig. A1.2. If this field is blank or contains a zero, the I_o will be calculated as a percentage of the three-digit element specified in Columns 41 through 50.

A1.2.2.5 Column 25, Orientation of the I_o Shape—This field is used to define the relationship between the local coordinate system of the I_o item as shown in Fig. A1.2 and the ship's coordinate system. The entries to be used are as follows:

- 0 – X axis of the shape as shown in Fig. A1.2 is oriented in the ship's longitudinal direction.
- 1 – X axis of the shape as shown in Fig. A1.2 is oriented in the ship's transverse direction.
- 2 – X axis of the shape as shown in Fig. A1.2 is oriented in the ship's vertical direction.

NOTE A1.2—The orientation of the shape relative to the ship's coordinate system need not have any sign for the calculation of the inertia. For example, the inertia of the pyramid (Shape 5 in Fig. A1.2) about all three axes is the same whether the point of the pyramid is pointing in the positive X (to the right) or negative X direction (to the left). Therefore, for an item that is to be modeled as a pyramid with the point oriented to the

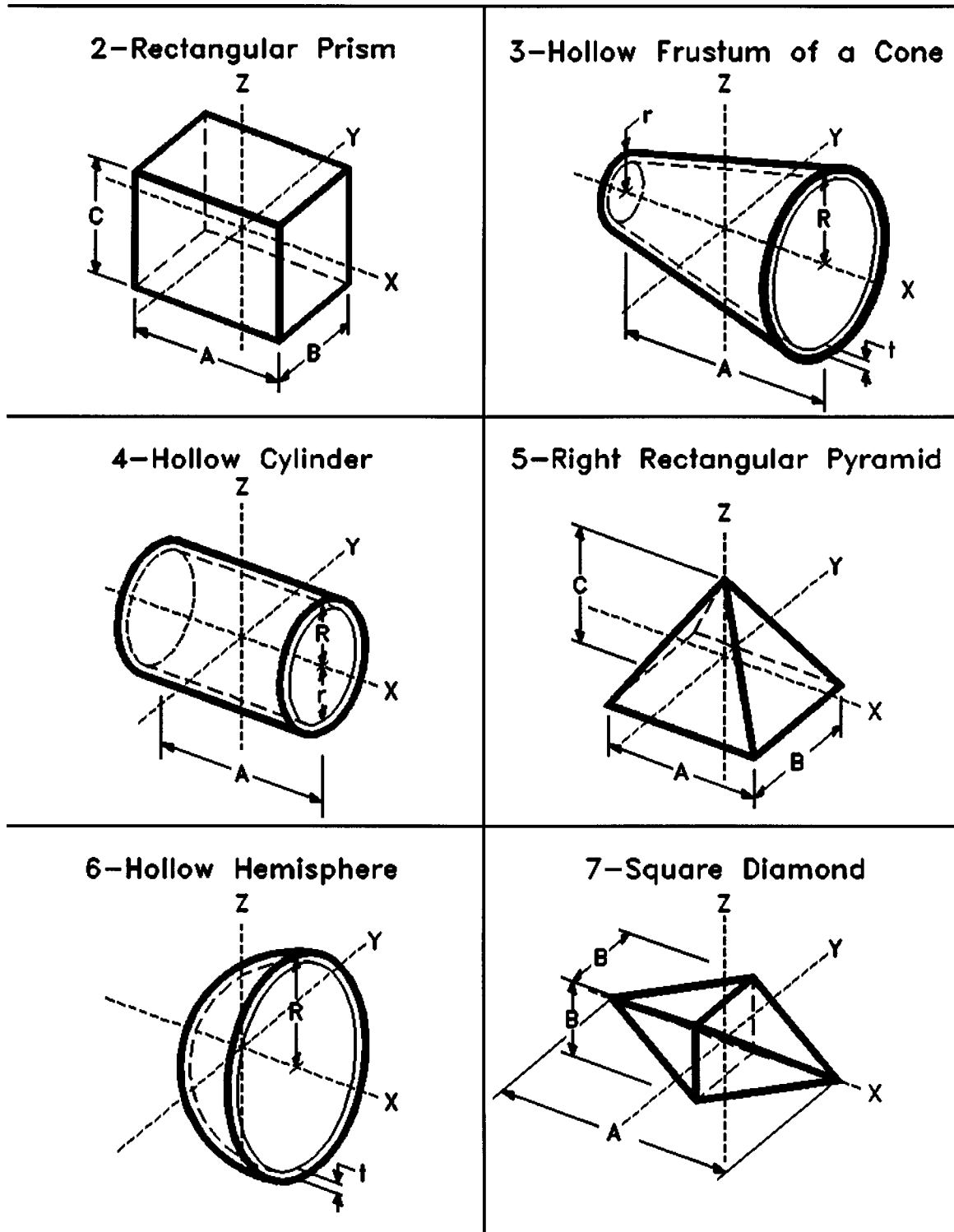

FIG. A1.2 Shapes for I_o Calculation

stern of the ship, the value to be entered for the orientation in Column 25 would still be "O," which is the same as if it were pointing to the bow.

A1.2.2.6 Columns 31-40, X-Dimension—For each of the shape definitions given in Column 20, the following information must be entered. The format for this field is right justified with an implied decimal point between Columns 38 and 39.

Shape (Column 20)
0 or Blank

X-dimension (Columns 31-40).
– Blank or zero means the ratio of current weight to the weight of the specified element (entered in the Y-dimension field) is used to calculate the I_o or I_t (if 999 is entered in the Z-dimension field) or both, based on the specified element's I_o or I_t or both.

- Percentage, which is used to calculate the item's I_o or I_t or both, based on the specified element's (entered in the Y-dimension field) I_o or I_t or both. For 1 % enter 100, for 0.05 % enter 5, and so forth.
- 1 — I_o about the local axis oriented in the ship's longitudinal direction.
- 2, 3, 4, 5, 7 — X-dimension (A of Fig. A1.2).
- 6 — Blank.

A1.2.2.7 For the percentage option (0 or blank in Column 20), there are two possible options for calculating the I_o or I_t terms or both. For the first option, the X-dimension field is left blank, and there is a three-digit element number contained in the Y-dimension field. For this case, the I_o for the data line will be calculated as a percentage of the I_o for the specified element. The percentage used will be the weight of the data line to the element weight. If 999 is entered in the Z-dimension field, the I_t will be calculated in a similar manner. If a percentage is inserted in the X-dimension field and a three-digit element number is in the Y-dimension field, the I_o will be calculated as the defined percentage of the I_o for the specified element. If 999 is entered in the Z-dimension field, the I_t will be calculated in a similar manner.

A1.2.2.8 *Columns 41–50, Y-Dimension*—For each of the shape definitions given in Column 20, the following information must be entered. The format for this field is right justified with an implied decimal point between Columns 48 and 49.

- | | |
|-------------------|--|
| Shape (Column 20) | Y-dimension (Columns 41-50). |
| 0 or Blank | — Three-digit element on which I_o or I_t or both percentage calculation is based. If blank, the calculation will be based on the current three-digit element. |
| 1 | — I_o about local axis oriented in the ship's transverse direction. |
| 2, 5, 7 | — Y-dimension (B of Fig. A1.2) |
| 3, 4, 6 | — Outer Radius (R of Fig. A1.2) |

A1.2.2.9 *Columns 51–60, Z-Dimension*—For each of the shape definitions given in Column 20, the following information must be entered. The format for this field is right justified with an implied decimal point between Columns 58 and 59.

- | | |
|-------------------|---|
| Shape (Column 20) | Z-dimension (Columns 51-60) |
| 0 or Blank | — If blank, only the I_o calculation will be done using a ratio or an entered percentage. If 999 is entered, then both the I_o and I_t calculation will be done using a ratio or an entered percentage. |
| 1 | — I_o about the local axis oriented in the ship's vertical direction. |
| 2, 5 | — Z-dimension (C of Fig. A1.2). |
| 3, 4 | — Inner Radius (r of Fig. A1.2). |
| 6, 7 | — Blank. |

A1.2.2.10 *Columns 61–70, T-Dimension*—For each of the shape definitions given in Column 20, the following information must be entered. The format for this field is right justified with an implied decimal point between Columns 68 and 69.

- | | |
|-------------------|-------------------------------|
| Shape (Column 20) | T-dimension (Columns 61-70). |
| 0, 1, 2, 4, 5, 7 | — Blank. |
| or Blank | — Thickness (t of Fig. A1.2). |
| 3, 6 | |

A1.2.2.11 *Columns 79–80, Report Number*—Enter the report number in which the change was first incorporated as described for the first line of data.

A1.3 General Input Data Requirements:

A1.3.1 *Load Titles*—Line items for titles shall be prepared for each required load condition, and for each load element comprising that condition, in accordance with ESWBS in the following format:

- | | |
|-----------------------|------------------------------------|
| Column 1 | — Alpha load condition designator. |
| Columns 2 and 3 | — Load element number. |
| Columns 4 and 5 | — Zeroes. |
| Column 10 | — Zero. |
| Columns 14 through 37 | — Load element title. |

A1.3.2 *Load Details*—Loads for ESWBS are classified in much the same manner as light ship elements in Groups 1 through 7 and follow the same format. Input data must be prepared for all detail load items comprising the full-load condition (F in Column 1). The letters “A” through “L” are used in Column 1 to indicate various other loading conditions.

A1.3.3 *Margins*—Margins for ESWBS are classified in accordance with ESWBS. The weight and moment of each margin will be distributed automatically over the 22 longitudinal stations in proportion to the light ship weight distribution. The margins either can be input as a total weight or as a percentage of total light ship displacement. Line items for margins are prepared in a similar manner to light ship details. The first line item of the margin group shall be a title of the form “M0000—0—Margins,” beginning in Column 1. Margin depletions are handled as negative detail weight entries, in the same manner as light ship details, and follow the same format. Margin options are as follows:

A1.3.3.1 *Option 1, Input Weight*—Enter the total margin weight in pounds in Columns 46 through 53 and centers of gravity as desired. All or any centers of gravity may be left blank. The margins will then be automatically positioned at the light ship centers of gravity.

A1.3.3.2 *Option 2, Percentage*—Margin may be computed as a percentage of total light ship. In the unit weight, Columns 46 through 53, enter the percentage desired (for example: 4 % = 4.00). Enter zero in Column 57 of number of units. Centers of gravity may be entered or left blank. If left blank, margins will be placed at light ship centers of gravity.

A1.3.4 *Titles*—Titles for Groups 1 through 7 are included in the Navy program. All other titles shall be prepared by the user. A title shall be prepared for each of the ESWBS elements.

A1.4 *Data Transfer*—Input data files, when required by the contract or ship specifications, shall be transferred on electronic media and in ASCII format.

NOTICE: This standard has either been superseded and replaced by a new version or discontinued. Contact ASTM International (www.astm.org) for the latest information.



F 1808

APPENDIX

(Nonmandatory Information)

X1. SUGGESTED FORMS FOR WEIGHT ESTIMATION

X1.1 The suggested forms for weight estimation are shown in Figs. X1.1-X1.8.

SHIP		DATE		BY		SHEET			
		CONDITION		CG ABOVE BASE		CG FROM			
CONDITION	ITEM	DISPL. AND WEIGHT	VERT LEVER	VERTICAL MOMENTS	LONG. AFT LEVER	LONG. AFTER MOMENTS	LONG. FWD LEVER	LONG. FORWARD MOMENTS	FREE SURFACE
	HULL STRUCTURE								
	OUTFIT								
	MACHINERY								
	SUBTOTAL								
	FIXED BALLAST								
	SUBTOTAL								
	WEIGHT MARGIN _____%								
	KG MARGIN								
TOTAL - SHIP IN CONDITION									
MEAN S.W. DRAFT	_____	LCG	_____	_____	_____	_____	_____	_____	LCF
KM	_____	LCB	_____	_____	_____	_____	_____	_____	DRAFT FWD.
KG	_____	TRIM LEVER FWD, AFT	_____	_____	_____	_____	_____	_____	DRAFT AFT
GM	_____	MOMENT TO TRIM _____	_____	_____	_____	_____	_____	_____	
CORR. FOR F.S.	_____	TRIM IN _____ FWD, AFT	_____	_____	_____	_____	_____	_____	
GM AVAILABLE	_____								
GM REQUIRED	_____								

FIG. X1.1 Sample Form #1



HULL STRUCTURE (Weight Calculations)							
CODE	ITEM	WEIGHT	VERT. LEV.	VERT. MOM.	LONG. LEV.	LONG. MOM.	
0-0	Stem casting						
1	Stern frame casting						
2	Boss casting						
3	Shaft struts						
4	Misc. Hull Castings						
5							
6							
7							
8							
9							
Forgings and Castings							
1-0	Flat Plate keel						
1	Shell plating						
2	Bulwarks						
3	Bilge keels						
4	Boss plating						
5	Rubbing strips and fenders						
6	Sea Chests / Skin coolers						
7	Skegs						
8	Thruster Tunnels / Wells						
9							
Shell Plating							
2-0	Center vertical keel						
1	Trans. framing in 1.B.						
2	Long. framing in 1.B.						
3	Trans. framing outside 1.B.						
4	Framing in peaks						
5	Transom and cants						
6	Web frames						
7	Long'l Girder Ring						
8	Long'l Stringer Ring						
9							
Framing							
3-0							
1							
2							
3							
4							
5							
6							
7							
8							
9							
Deck Plating and Beams							
4-0	Main trans. W.T. bhds.						
1	Trans. W.T. and O.T. bhds						
2	Long. W.T. and O.T. bhds						
3	Structural N.W.T. bhds						
4	Non-structural bhds						
5	Trunks - structural						
6	Trunks - non-structural						
7	Stair enclosures						
8	Hatch Coamings						
9	Drill Wells / Leg Wells						
Bulkheads and Trunks							
DESIGN		DATE			DIMENSIONS		

FIG. X1.2 Sample Form #2

 **F 1808**

HULL STRUCTURE (Weight Calculations)							
CODE	ITEM	WEIGHT	VERT. LEV.	VERT. MOM.	LONG. LEV.	LONG. MOM.	
5-0	Pillars and Girders						
1							
2							
3							
4							
5							
6							
7							
8							
9							
Pillars and Girders							
6-0	Inner Bottom Plating						
1	Platform Deck						
2	Sponsons						
3	Cantilevers						
4	Cofferdam Flats & Floors						
5	Helicopter Platform						
6	Miscellaneous Flats and Floors						
7	Stability Column Support Legs						
8	Protective Covers / Barriers						
9							
Hull Miscellaneous							
7-0	Main Engine Foundations						
1	Boiler Foundations						
2	Auxiliary Machine Foundations						
3	Shaft Stools Foundations						
4	Miscellaneous Foundations						
5	Cryogenic / Chemical Foundations						
6							
7							
8							
9							
Foundations							
8-0							
1							
2							
3							
4							
5							
6							
7							
8	Miscellaneous Houses						
9	Stack Enclosure						
Superstructures							
SUB TOTAL GROUPS 0 THROUGH 8							
9-0	Riveting and Welding						
1	Welding						
2	Mill Tolerance						
3							
4							
5							
6							
7							
Riveting and Welding							
TOTAL HULL STRUCTURE							
DESIGN		DATE			DIMENSIONS		

FIG. X1.3 Sample Form #3



OUTFIT SUMMARY (Weight Calculations)							
CODE	ITEM	WEIGHT	VERT. LEV.	VERT. MOM.	LONG. LEV.	LONG. MOM.	
10-0	Steel Masts, Kingposts, etc.						
1	Steel Booms						
2	Steel Hatch Covers and Beams						
3	Steel Stairways						
4	Steel Sheet Metal Work						
5	Drill Derricks						
6	Self-Unloading Booms						
7							
8							
9							
Struc. Steel in Outfit							
11-0	Deck Castings, Mooring Ftgs.						
1	Mast and Spar Forgings						
2	Rails and Stanchions						
3	Ladders						
4	Miscellaneous Hull Fittings						
5	Ratproofing						
6	Guide Struc. / Lashings						
7	Prim. Cryogenic Contain.						
8	Sec. Cryogenic Contain.						
9	Tug / Barge Connections						
Hull Attachments							
12-0	Sliding W.T. Doors						
1	Hinged W.T. Doors						
2	Manholes and Scuttles						
3	Airports, Windows and Lights						
4	Hatches and Ports O.T. or W.T.						
5	N.W.T. Steel Doors						
6	Skylights and Companions						
7	Movable Ramps						
Lights, Doors Hatches, Ramps							
13-0	Wooden Masts and Spars						
1	Wood Hatch Covers						
2	Hold Ceiling and Sparring						
3	Miscellaneous Carpenter Work						
4	Wood Decks						
5	Wood Houses						
6	Composition Dk. Covering						
7	Sheet / Block Dk. Tile						
8	Ceramic / Misc. Dk. Tile						
9	Cement and Misc. Coverings						
Carpenter Work and Decking							
14-0	Interior Joiner Work						
1	Furniture						
2							
3	Joiner Decks						
4	Decorative Joiner Work						
5	Accomodation Ladder						
6							
7	Special Insulation						
8	Insulation in Quarters						
9	Fire Insulation						
Joiner Work							
DESIGN					DATE		

FIG. X1.4 Sample Form #4

 **F 1808**

OUTFIT SUMMARY (Weight Calculations)							
CODE	ITEM	WEIGHT	VERT. LEV.	VERT. MOM.	LONG. LEV.	LONG. MOM.	
15-0	Anchors, Chains, Lines						
1	Boats and Boat Handling						
2	Rigging and Blocks						
3	Canvas Work						
4	Miscellaneous Deck Outfit						
5	Underwater Support Equipment						
6	Exterior Paint						
7	Interior Paint						
8	Tank Paint						
9	Special Coatings						
Deck Outfit							
16-0	Galley and Pantry Equipment						
1	Utility Space Equipment						
2	Steward's Outfit						
3							
4							
5							
6							
7	National Defense						
8							
9							
Steward's Outfit / Defense							
17-0	Fire Det. and Ext. System						
1	Heating System						
2	Ventilation - Natural						
3	Ventilation - Mechanical						
4	Refrigerating Systems						
5	Plumbing Fixtures and Drains						
6							
7							
Hull Engineering							
18-0	Bilge and Ballast System						
1	Cargo Oil System						
2	Deck Steam and Ex. System						
3	Fire Mains						
4	San. and Fresh Water System						
5	Fuel Oil Transfer System						
6	Vents, Snd. and Overflows						
7	Cryogenic / Chem. Cargo Sys.						
8	Inerting / Nitrogen System						
9	Hydraulic System						
Piping							
19-0	Deck Machinery						
1	Steer. Gear and Rudder						
2	Communicating System						
3	Electric Plant						
4	Dumb Waiters and Elevators						
5	Auxiliary Boiler						
6	Dest. Plant (ship use)						
7	Stabilizers						
8	Thrusters						
9	Bulk Unloading						
Miscellaneous Machinery							
TOTAL OUTFIT							
DESIGN					DATE		

FIG. X1.5 Sample Form #5



MACHINERY SUMMARY (Weight Calculations)							
CODE	ITEM	WEIGHT	VERT. LEV.	VERT. MOM.	LONG. LEV.	LONG. MOM.	
20-0	Main Propulsion						
1	Turbine Drain and Leak-Off System						
2	Main Reduction Gears						
3	Main Condenser						
4	Main Air Ejector						
5	Main Circulating System						
6							
7							
TOTAL - Main Propulsion Units							
21-0	Feed Heaters						
1	Feed and Condensate System						
2							
3							
TOTAL - Feed and Condensate Equip.							
22-0	Makeup Feed System						
1	Contaminated System						
2	Salt Water Evap. System						
3							
4							
TOTAL - Evaporator System							
23-0	Shafting						
1	Bearings and Stern Tube						
2	Propellers						
3	Miscellaneous Shafting Parts						
4	Shafting and Propeller Spares						
5							
6							
TOTAL - Shafting and Propellers							
24-0	Lub. Oil System						
1	Miscellaneous Engine Oil Tanks						
2							
3							
TOTAL - Lubricating Oil System							
25-0	Service Compressed Air Serv. Sys.						
1	Starting Air System						
2	Scavenger Air System						
3							
4							
TOTAL - AIR SYSTEM							
DESIGN					DATE		
TYPE			SHIP			RPM	

FIG. X1.6 Sample Form #6



MACHINERY SUMMARY (Weight Calculations)							
CODE	ITEM	WEIGHT	VERT. LEV.	VERT. MOM.	LONG. LEV.	LONG. MOM.	
26-0	Boilers						
1	Fuel Oil Burners						
2	Soot Blowers						
3	Boiler Draft System						
4	Automatic Combustion Control						
5	Stacks and Uptakes						
6	F.O. Service System						
7	LNG Boil Off System						
8							
TOTAL - Boilers and F.O. System							
27-0	Main Steam Piping						
1	Auxiliary Steam Piping						
2	Exhaust and Escape Piping						
3	Steam Drain System						
4	Whistles						
5							
6							
TOTAL - Steam Piping							
28-0	Access						
1	Work Shop						
2	Lifting and Handling Gear						
3	Machinery Space Ventilation						
4	Machinery Space Fixtures						
5	Spare Parts						
6	Miscellaneous Instruments and Gages						
7							
8							
TOTAL - Miscellaneous							
29-0	Liquids in Machinery (Gr. 12-19)						
1	Water (Gr. 20-28)						
2	Oil (Gr. 20-28)						
3							
4							
TOTAL - Liquids in Machinery							
TOTAL - MACHINERY							
DESIGN					DATE		
TYPE			SHIP		RPM		

FIG. X1.7 Sample Form #7

NOTICE: This standard has either been superseded and replaced by a new version or discontinued. Contact ASTM International (www.astm.org) for the latest information.



The American Society for Testing and Materials takes no position respecting the validity of any patent rights asserted in connection with any item mentioned in this standard. Users of this standard are expressly advised that determination of the validity of any such patent rights, and the risk of infringement of such rights, are entirely their own responsibility.

This standard is subject to revision at any time by the responsible technical committee and must be reviewed every five years and if not revised, either reapproved or withdrawn. Your comments are invited either for revision of this standard or for additional standards and should be addressed to ASTM Headquarters. Your comments will receive careful consideration at a meeting of the responsible technical committee, which you may attend. If you feel that your comments have not received a fair hearing you should make your views known to the ASTM Committee on Standards, 100 Barr Harbor Drive, West Conshohocken, PA 19428.