



Standard Specification for Welded Joints for Shipboard Piping Systems¹

This standard is issued under the fixed designation F 722; the number immediately following the designation indicates the year of original adoption or, in the case of revision, the year of last revision. A number in parentheses indicates the year of last approval. A superscript epsilon (ϵ) indicates an editorial change since the last revision or reapproval.

This standard has been approved for use by agencies of the Department of Defense.

1. Scope

1.1 This specification covers typical details of welded joints commonly used in shipboard piping systems. These joints and other joints may be used provided the welding procedures used have been qualified in accordance with the applicable regulatory rules and regulations.

1.2 The values stated in inch-pound units are to be regarded as the standard.

2. Referenced Documents

2.1 Federal Standards:

Code of Federal Regulations Title 46, Shipping, Parats 30 to 40²

Code of Federal Regulations Title 46, Shipping, Parts 41 to 69²

Code of Federal Regulations Title 46, Shipping, Parts 140 to 149²

Rules for Building and Classing Steel Vessels³

3. Application, Service, Limitations, and List of Weld Joint Details

3.1 Details of welded joints, including application, service, and limitation notes, are provided in the appropriate figures, as follows:

3.1.1 *Butt-Welded Joints for Pipes, Valves, Fittings, and Flanges:*

Fig. 1 Butt Joint, Square

Fig. 2 Butt Joint, V-Grooved

Fig. 3 Butt Joint, V-Grooved, Welded Both Sides

Fig. 4 Butt Joint, Double V-Grooved, Welded Both Sides

Fig. 5 Butt Joint, Compound Bevel V-Grooved, Welded Both Sides

Fig. 6 Butt Joint, V-Grooved, Miter Type

Fig. 7 Butt Joint, V-Grooved, Welded with Bevel End-Type Backing Ring

Fig. 8 Butt Joint, Compound Bevel V-Grooved, Welded with Bevel End-Type Backing Ring

Fig. 9 Butt Joint, V-Grooved Welded with Bevel End Lug-Type Backing Ring

Fig. 10 Butt Joint, V-Grooved, Welded with Square End-Type Backing Ring

Fig. 11 Butt Joint, V-Grooved, Welded with Consumable Insert Ring

Fig. 12 Butt Joint, Compound Bevel V-Grooved, Welded with Consumable Insert Ring

Fig. 13 Butt Joint, U-Grooved, Welded with Consumable Insert Ring

Fig. 14 Butt Joint, V-Grooved, Welded with Consumable Insert Ring

Fig. 15 Butt Joint, Socket Weld to Socket Weld Valve, Fitting or Flange Welded on Pipe Nipple

Fig. 16 Butt Joint, Transition between Unequal Inside and Outside Diameter Components

3.1.2 *Fillet Welded Joints for Valves, Fittings, and Flanges:*

Fig. 17 Fillet Welded Sleeve-Type Pipe Coupling

Fig. 18 Fillet Welded Socket Weld Fitting or Valve

Fig. 19 Fillet Welded Socket Weld-Flange

Fig. 20 Double Fillet Welded Slip-On Flange (Forged)

Fig. 21 Double Fillet Welded Slip-On Flange (Plate Type)

Fig. 22 Fillet Welded Slip-On Flange (Plate Type), Single Bevel

3.1.3 *Fabricated Joints:*

Fig. 23 Fillet Welded Internal Root Connection

Fig. 24 Fillet Welded External Root Connection

Fig. 25 Fillet Reinforced External Root Connection Single Bevel

Fig. 26 Fillet Reinforced External Root Connection, Single Bevel, Welded Both Sides

Fig. 27 Fillet Reinforced External Root Connection, Single Bevel, Welded with Square End Backing Ring

Fig. 28 Fillet Reinforced Internal Root Connection, Single Bevel, Welded with Square End Backing Ring

3.1.4 *Outlet and Boss Connections:*

¹ This specification is under the jurisdiction of ASTM Committee F25 on Ships and Marine Technology and is the direct responsibility of Subcommittee F25.11 on Machinery and Piping Systems.

Current edition approved July 30, 1982. Published August 1982. Originally published as F 722 – 81. Last previous edition F 722 – 81.

² Available from Superintendent of Documents, U.S. Government Printing Office, Washington, DC 20402.

³ Available from American Bureau of Shipping, ABS Plaza, 16855 Northchase Dr., Houston, TX 77060.

Fig. 29 Fillet Reinforced Boss Connection Without Pilot, Single Bevel

Fig. 30 Fillet Reinforced Boss Connection with Pilot, Single Bevel

Fig. 31 Fillet Reinforced Boss Connection (Couplet) with Integral Backing Ring

Fig. 32 Fillet Reinforced External Root Connection, Single Bevel with Integrally Reinforced Outlet

Fig. 33 Fillet Reinforced External Root Connection Welded Both Sides, Single Bevel with Integrally Reinforced Outlet

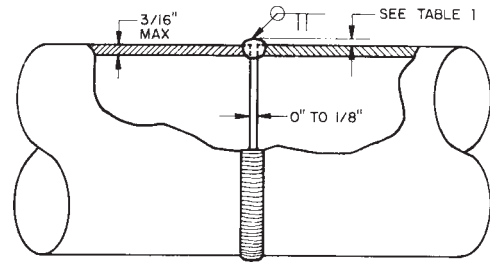

1/8 in. = 3 mm
3/16 in. = 5 mm

Application—Class II piping
Systems or Service—For services such as gravity drains (including plumbing), vents, and overflows.
Remarks—1. Root of weld need not be ground.

FIG. 1 Butt Joint, Square

4. Piping Classifications and Butt Weld Reinforcements

4.1 Piping classifications in accordance with Subpart 56.04 of USCG Regulations apply to this specification. For definitions of ABS Group I and II Pipe Connections, see ABS Rules, Section 30, Paragraph 30.13.

4.2 Maximum thickness of butt weld reinforcements in accordance with Subpart 56.70, Table 56.70-15, of USCG Regulations are listed in Table 1.

5. Keywords

5.1 backing ring pipe welds; boss connections; flange welds; miter joint weld; pipe welds; root connections; sleeve pipe welds; socket welds; welded joints

TABLE 1 Maximum Butt Weld Reinforcement, in. (mm)

NOTE 1—For double-welded butt joints, this limitation on reinforcement given above applies separately to both inside and outside surfaces of the joint.
NOTE 2—For single-welded butt joints, the reinforcement limits given above apply to the outside surface of the joint only.
NOTE 3— The thickness of weld reinforcement is based on the thickness of the thinner of the materials being joined.
NOTE 4—The weld reinforcement thicknesses must be determined for the higher of the abutting surfaces involved.
NOTE 5—For boiler external piping, use the column titled “above 750°F” for weld reinforcement thicknesses.
NOTE 6—See 4.2.

Nominal Wall Thickness of Pipe or Tube, in.	Maximum Operating Temperature of Piping System, °F (°C)			
	0 to 350 (-18 to 177)	to	350 to 750 (177 to 399)	to Above 750 (399)
Up to 1/8	3/16 (5)		3/32 (2)	1/16 (2)
Over 1/8 to 3/16	3/16 (5)		1/8 (3)	1/16 (2)
Over 3/16 to 1/2	3/16 (5)		5/32 (4)	1/16 (2)
Over 1/2 to 1	3/16 (5)		3/16 (5)	3/32 (2)
Over 1 to 2	1/4 (6)		1/4 (6)	1/8 (3)
Over 2	greater of 1/4 (6) or 1/8 the width of the weld		greater of 1/4 (6) or 1/8 the width of the weld	

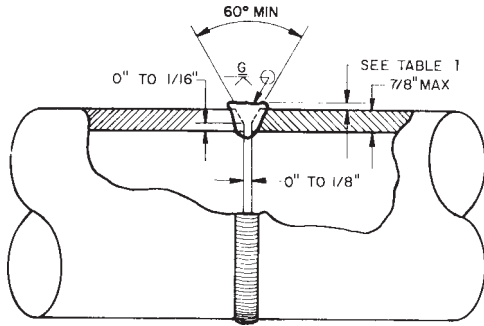

1/16 in. = 2 mm
 1/8 in. = 3 mm
 7/8 in. = 22 mm

Application—Class II piping
 System or Service—All provided root of weld is visually inspected where possible to ensure complete weld penetration.
 Remarks—1. For services such as vents, overflows, and gravity drains (including plumbing) the root of the weld need not be ground.

FIG. 2 Butt Joint, V-Grooved

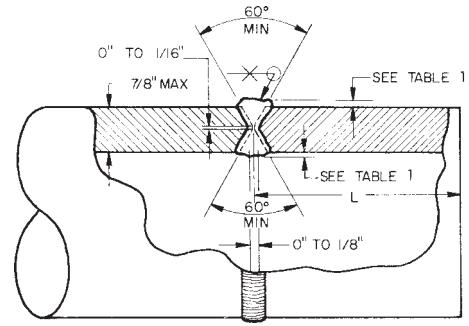

1/16 in. = 2 mm
 1/8 in. = 3 mm
 7/8 in. = 22 mm

Application—Class I and II piping above 2-in. NPS
 System or Service—All
 Remarks—1. Internal weld shall be made first and ground, chipped, or cleaned by some other means to assure sound welds.
 2. The "L" dimension should be held to a minimum to facilitate welding and inspection on the inside surface of the pipe.

FIG. 4 Butt Joint, Double V-Grooved, Welded Both Sides

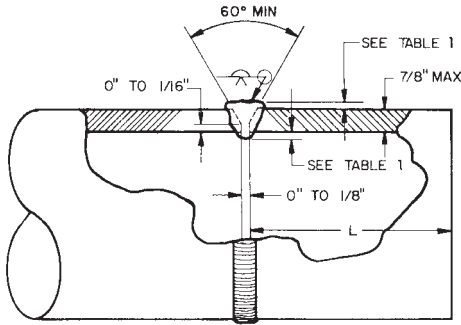

1/16 in. = 2 mm
 1/8 in. = 3 mm
 7/8 in. = 22 mm

Application—Class I and II piping above 2-in. NPS
 System or Service—All
 Remarks—1. Internal weld shall be made first and ground, chipped, or cleaned by some other means to assure sound welds.
 2. The "L" dimension should be held to a minimum to facilitate welding and inspection on the inside surface of the pipe.

FIG. 3 Butt Joint, V-Grooved, Welded Both Sides

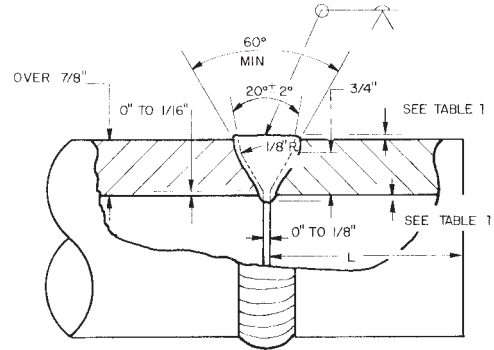

in.	1/16	1/8	3/4	7/8
mm	2	3	19	22

Application—Class I and II piping above 2-in. NPS
 Systems or Service—All
 Remarks—1. Internal weld shall be made first and ground, chipped, or cleaned by some other means to assure sound welds.
 2. The "L" dimension should be held to a minimum to facilitate welding and inspection on the inside surface of the pipe.

FIG. 5 Butt Joint, Compound Bevel V-Grooved, Welded Both Sides

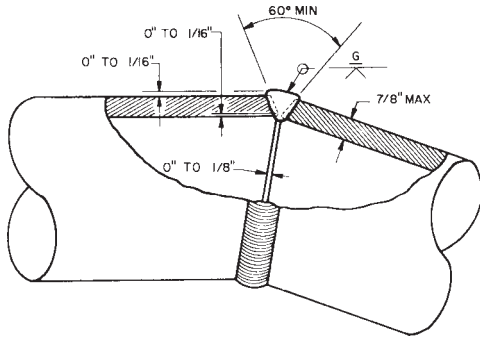

1/16 in.	=	2 mm
1/8 in.	=	3 mm
7/8 in.	=	22 mm

Application—Class II piping where use will not cause objectionable pressure drop or turbulence.

System or Service—All provided root of weld is visually inspected where possible to ensure complete weld penetration.

Remarks—1. For services such as vents, overflows, and gravity drains (including plumbing), the root of the weld need not be ground.

2. Miter segments shall be designed in accordance with ANSI B31.1, paragraph 104.33, and 46 CFR 56.07-10(f).

FIG. 6 Butt Joint, V-Grooved, Miter Type

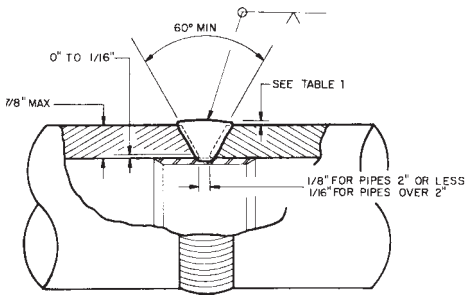

in.	1/16	1/8	3/16	7/8
mm	2	3	5	22

Application—Class I and II piping

System or Service—All, except as noted in remarks

Remarks—1. Backing ring may be tack-welded in place to facilitate fabrication.

2. When used in the following services, backing rings shall be removed.

(A) Lube oil service discharge piping from the lube oil pumps to the reduction gears, HP and LP turbines, and lube oil gravity tank.

(B) Superheated steam outlet piping from the main boilers to the HP and LP turbines and turbo generators and desuperheated steam from the main boilers to turbine driven main feed pumps.

(C) Central hydraulic systems.

FIG. 7 Butt Joint, V-Grooved, Welded with Bevel End-Type Backing Ring

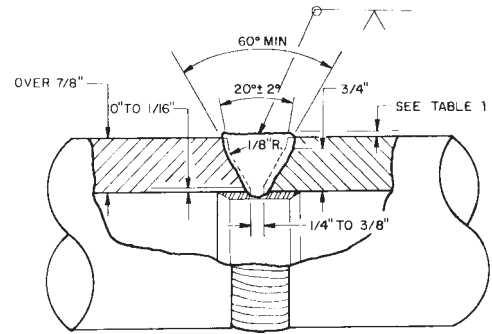

in.	1/16	1/8	1/4	3/8	3/4	7/8
mm	2	3	6	10	19	22

Application—Class I and II piping

System or Service—All, except as noted in remarks

Remarks—1. Backing ring may be tack-welded in place to facilitate fabrication.

2. When used in the following services, backing rings shall be removed.

(A) Lube oil service discharge piping from the lube oil pumps to the reduction gears, HP and LP turbines, and lube oil gravity tank.

(B) Superheated steam outlet piping from the main boilers to the HP and LP turbines and turbo generators and desuperheated steam from the main boilers to turbine driven main feed pumps.

(C) Central hydraulic systems.

FIG. 8 Butt Joint, Compound Bevel V-Grooved, Welded with Bevel End-Type Backing Ring

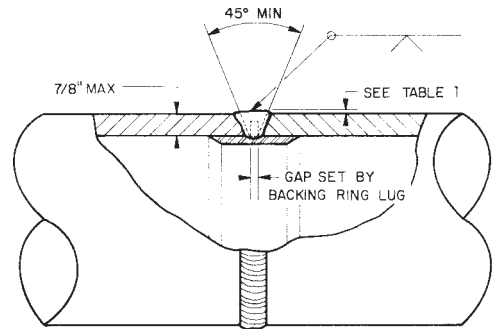

7/8 in. = 22 mm

Application—Class I and II piping

Systems or Service—All, except as noted in remarks

Remarks—1. Backing ring may be tack-welded in place to facilitate fabrication

2. When used in the following services, backing rings shall be removed.

(A) Lube oil service discharge piping from the lube oil pumps to the reduction gears, HP and LP turbines, and lube oil gravity tank.

(B) Superheated steam outlet piping from the main boilers to the HP and LP turbines and turbo generators and desuperheated steam from the main boilers to turbine driven main feed pumps.

(C) Central hydraulic systems.

FIG. 9 Butt Joint, V-Grooved Welded with Bevel End Lug-Type Backing Ring

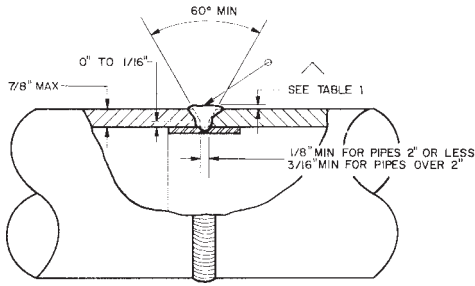

in.	1/16	1/8	3/16	7/8
mm	2	3	5	22

Application—Class I and II piping

System or Service—All

Remarks—1. After welding, backing ring shall be machined flush with inside diameter of pipe or fitting.

FIG. 10 Butt Joint, V-Grooved, Welded with Square End-Type Backing Ring

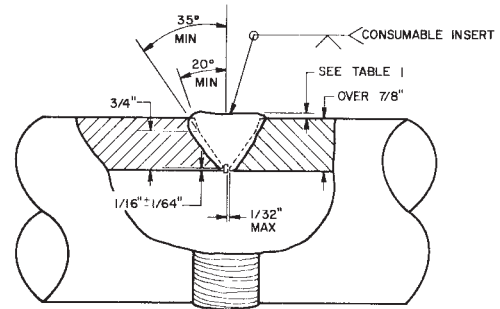

in.	1/4	1/32	1/16	3/4	7/8
mm	0.4	1	2	19	22

Application—Class I and II piping

System or Service—All

Remarks—1. Internal misalignment of pipes shall not exceed 1/16 in. (2 mm).
2. Consumable insert ring shall be centered before welding.

FIG. 12 Butt Joint, Compound Bevel V-Grooved, Welded with Consumable Insert Ring

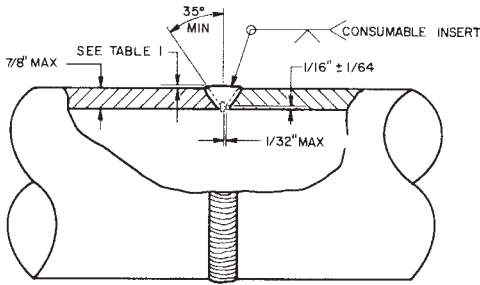

in.	1/64	1/32	1/16	7/8
mm	0.4	1	2	22

Application—Class I and II piping

System or Service—All

Remarks—1. Internal misalignment of pipes shall not exceed 1/16 in. (2 mm).
2. Consumable insert ring shall be centered before welding.

FIG. 11 Butt Joint, V-Grooved, Welded with Consumable Insert Ring

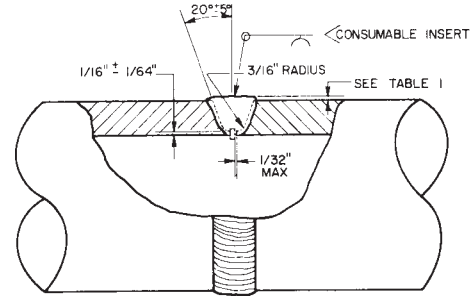

in.	1/64	1/32	1/16	3/16
mm	0.4	1	2	5

Application—Class I and II Piping

System or Service—All

Remarks—1. Internal misalignment of pipes shall not exceed 1/16 in. (2 mm).
2. Consumable insert ring shall be centered before welding.

FIG. 13 Butt Joint, U-Grooved, Welded with Consumable Insert Ring

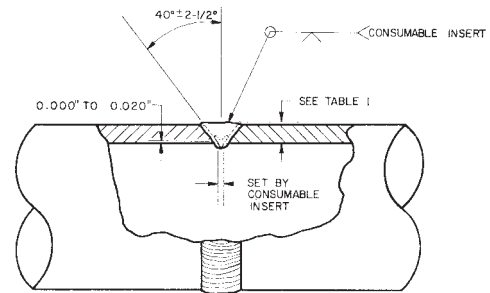

0.020 in. = 0.51 mm.

Application—Class I and II piping

System or Service—All

Remarks—1. Internal misalignment of pipes shall not exceed 1/32 in. (1 mm).
2. Consumable insert ring shall be centered before welding.

FIG. 14 Butt Joint, V-Grooved, Welded with Consumable Insert Ring

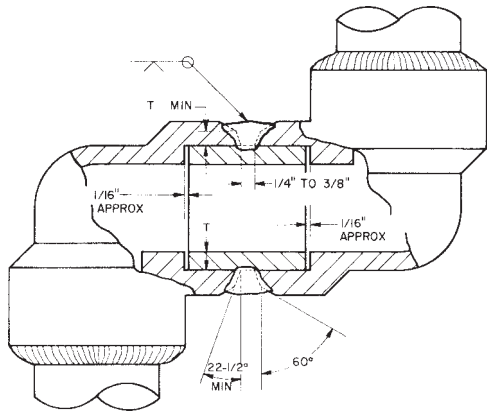

1/16 in. = 2 mm
 1/4 in. = 6 mm
 3/8 in. = 10 mm

Application—Fittings: See Fig. 18. Flanges: See Fig. 19.
 System or Service—See Fig. 18 and Fig. 19.

Remarks—1. Size of weld shall be equal to or greater than "T."

2. For Class I piping, depth of insertion of the pipe nipple into the fitting shall not be less than 3/8 in. (10 mm).

3. Weld to be deposited in a minimum of two passes unless specifically approved otherwise in a special procedure qualification.

FIG. 15 Butt Joint, Socket Weld to Socket Weld Valve, Fitting or Flange Welded on Pipe Nipple

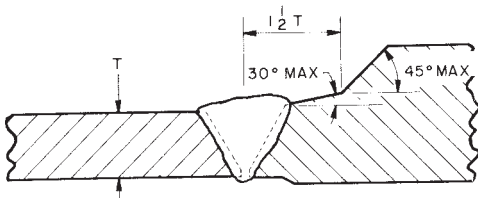
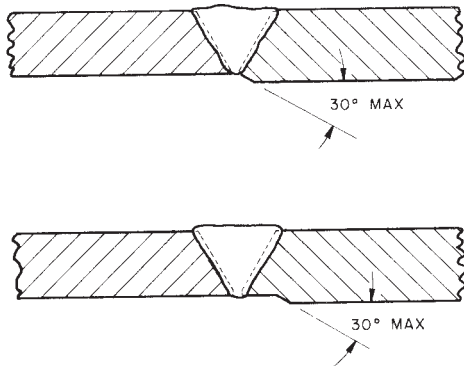
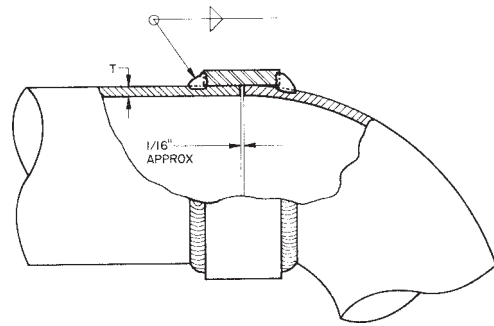

FIG. 16 Butt Joint, Transition Between Unequal Inside and Outside Diameter Components



1/16 in. = 2 mm

Application—Class I piping 3-in. NPS max where not subject to full radiography by 46 CFR Table 56.95-10. Class II piping all sizes.

Systems or Service—All

Remarks—1. Size of weld shall be 1.4 T min but not less than 1/8 in. (3 mm).

2. For Class I piping, depth of insertion of pipe, tube, or fitting in sleeve shall not be less than 3/8 in. (10 mm).

3. Weld to be deposited in a minimum of two passes unless specifically approved otherwise in a special procedure qualification.

4. For Class I piping, the inside diameter of the sleeve shall not exceed the outside diameter of the pipe, tube, or fitting by more than 0.080 in. (2.03 mm).

5. Couplings may be used with flat or beveled end pipes and fitting.

FIG. 17 Fillet Welded Sleeve-Type Pipe Coupling

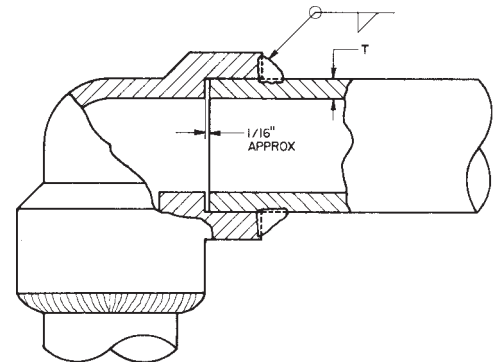

1/16 in. = 2 mm

Application—Class I piping 3-in. NPS max where not subject to full radiography by 46 CFR Table 56.95-10. Class II piping all sizes.

System or Service—All, except socket welds shall not be used where severe erosion or crevice corrosion is expected to occur.

Remarks—1. Size of weld shall be 1 1/4 T min but not less than 1/8 in. (3 mm).

2. For Class I piping, depth of insertion of pipe or tube into the fitting shall not be less than 3/8 in. (10 mm).

3. Weld to be deposited in a minimum of two passes unless specifically approved otherwise in a special procedure qualification.

FIG. 18 Fillet Welded Socket Weld Fitting or Valve

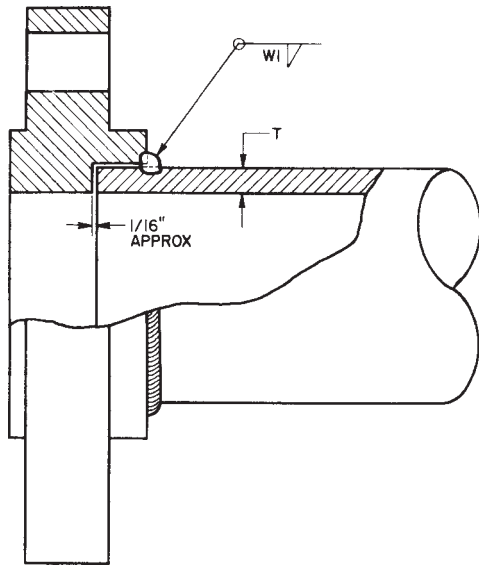

1/16 in. = 2 mm.

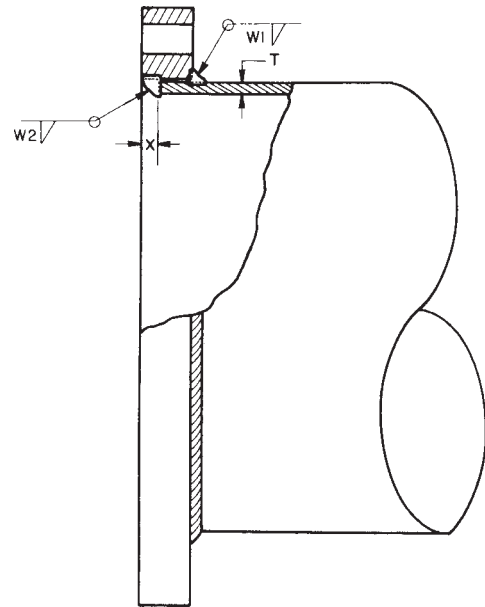

Application—Class I piping 3-in. NPS max for 600# and lower classes and 2½-in. NPS for 900 and 1500# classes. 3-in. size not permitted where subject to full radiography by 46 CFR Table 56.95-10. Class II piping all sizes.

System or Service—All, except socket welds shall not be used where severe erosion or crevice corrosion is expected to occur

Remarks—1. Size of Weld W1 shall be 1.4 T min. for Class II piping, size of weld may be limited to 17/32 in. (13 mm) max.

2. Weld to be deposited in a minimum of two passes unless specifically approved otherwise in a special procedure qualification.

FIG. 19 Fillet Welded Socket Weld Flange

Application—Class II piping not exceeding 150 psi (1034 kPa) or 450°F (232°C) System or Service—All

Remarks—1. Size of Weld 8a W1 shall be 1.4 “T” min but may be limited to 17/32 in. (13 mm).

2. Size of Weld W2 shall be equal to “T” or ¼ in. (6 mm), whichever is smaller.

3. Distance X shall be T plus 1/16 in. (2 mm) min but may be limited to 3/8 in. (10 mm).

FIG. 21 Double Fillet Welded Slip-on Flange (Plate Type)

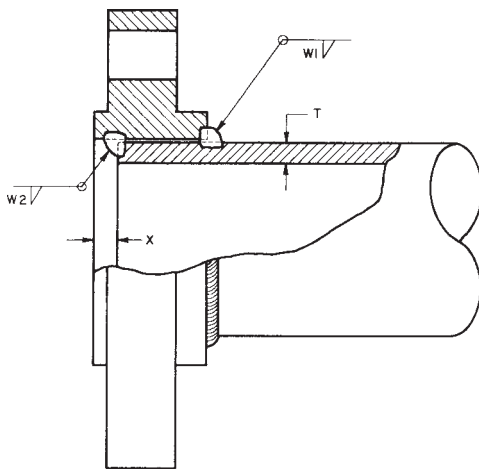

Application—Class I and II piping not to exceed the service pressure temperature ratings for the 300# and lower classes. Slip-on flanges shall not be used on Class I piping where subject to full radiography by 46 CFR Table 56.95-10.

System or Service—All

Remarks—1. Size of Weld W1 shall be 1.4 T min. for Class II piping, size of weld may be limited to 17/32 in. (13 mm) max.

2. Size of Weld W2 shall be equal to “T” or ¼ in. (6 mm), whichever is smaller.

3. Dimension X shall be equal to T plus 1/16 in. (2 mm) min. for Class II piping, Dimension X may be limited to 3/8 in. (10 mm).

FIG. 20 Double Fillet Welded Slip-on Flange (Forged)

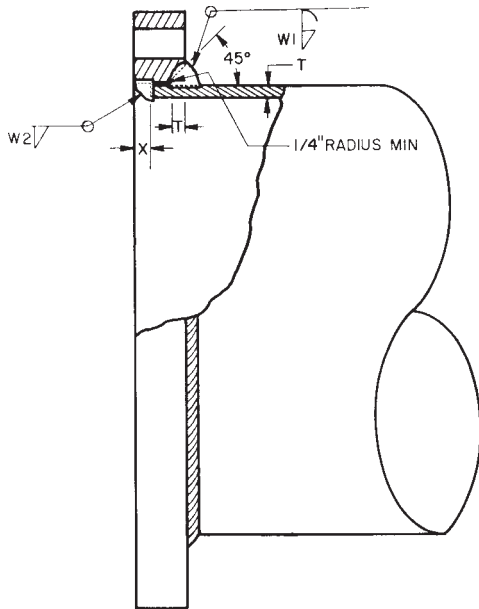

1/4 in. = 6 mm

Application—Class II piping not exceeding 150 psi (1034 kPa) or 650°F (343°C)
System or Service—All

Remarks—1. Size of Weld W1 shall be 1.4 "T" min but may be limited to 1 7/32 in. (13 mm).

2. Size of Weld W2 shall be equal to "T" or 1/4 in. (6 mm), whichever is smaller.

3. Distance X shall be "T" plus 1/16 in. (2 mm) min but may be limited to 3/8 in. (10 mm).

FIG. 22 Fillet Welded Slip-on Flange (Plate-Type) Single Bevel

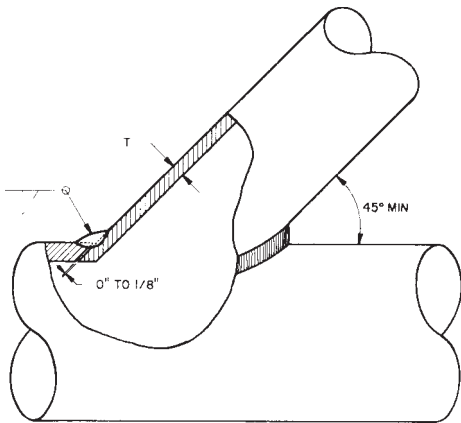

1/8 in. = 3 mm

Application—Class II piping

System or Service—For services such as vents, overflows, and gravity drains (including plumbing).

Remarks—1. Size of weld shall be T min.

FIG. 23 Fillet Welded Internal Root Connection

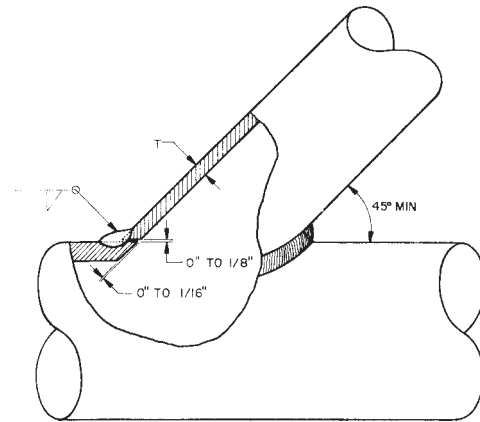

1/16 in. = 2 mm
1/8 in. = 3 mm

Application—Class II piping.

System or Service—For services such as vents, overflows, and gravity drains (including plumbing).

Remarks—1. Size of weld shall be T min.

FIG. 24 Fillet Welded External Root Connection

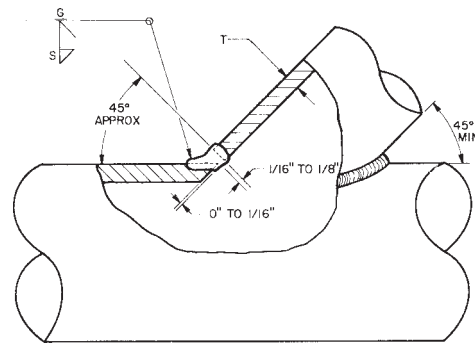

1/16 in. = 2 mm
1/8 in. = 3 mm

Application—Class II piping above 2-in. NPS.

System or Service—All, provided root of weld is visually inspected where possible to ensure complete weld penetration.

Remarks—1. Reinforcing fillet S shall have a minimum throat dimension of 0.7 T or 1/4 in. (6 mm), whichever is smaller.

2. For services such as vents, overflows, and gravity drains (including plumbing), the root of the weld need not be ground.

FIG. 25 Fillet Reinforced External Root Connection Single Bevel

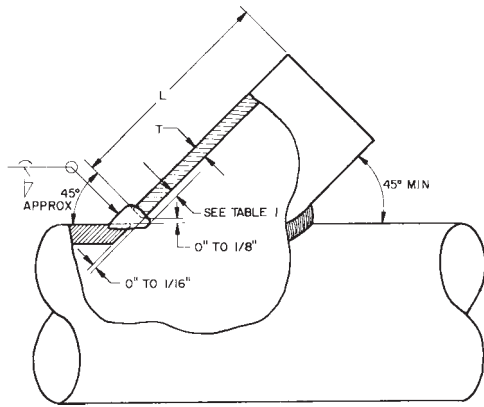

1/16 in. = 2 mm
 1/8 in. = 3 mm

Application—Class I and II piping above 2-in. NPS
 System or Service—All.

- Remarks—1. Reinforcing fillet S shall have a minimum throat dimension of 0.7 T or 1/4 in. (6 mm), whichever is smaller.
 2. Internal weld shall be made first and ground, chipped, or cleaned by some other means to assure sound welds.
 3. The “L” dimension should be held to a minimum to facilitate welding and inspection on the inside surface of the pipe.

FIG. 26 Fillet Reinforced External Root Connection, Single Bevel, Welded Both Sides

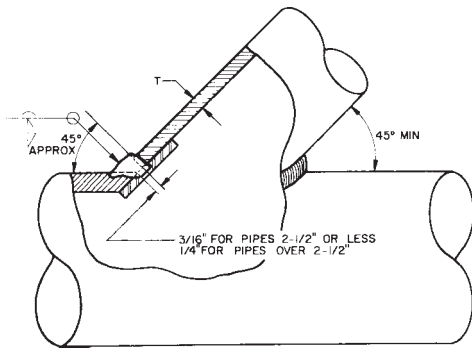

3/16 in. = 5 mm
 1/4 in. = 6 mm

Application—Class I and II piping.
 System or Service—All.

- Remarks—1. Reinforcing fillet S shall have a minimum throat dimension of 0.7 T or 1/4 in. (6 mm), whichever is smaller.
 2. After welding, backing ring shall be machined flush with inside diameter of pipe.

FIG. 27 Fillet Reinforced External Root Conn, Single Bevel, Welded with Square End Backing Ring

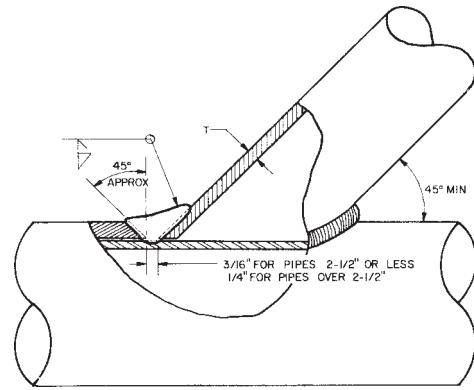

3/16 in. = 5 mm
 1/4 in. = 6 mm

Application—Class I and II piping.
 System or Service—All.

- Remarks—1. Reinforcing fillet S shall have a minimum throat dimension of 0.7 T or 1/4 in. (6 mm), whichever is smaller.
 2. After welding, backing ring shall be machined flush with inside diameter of pipe.

FIG. 28 Fillet Reinforced Internal Root Conn, Single Bevel, Welded With Square End Backing Ring

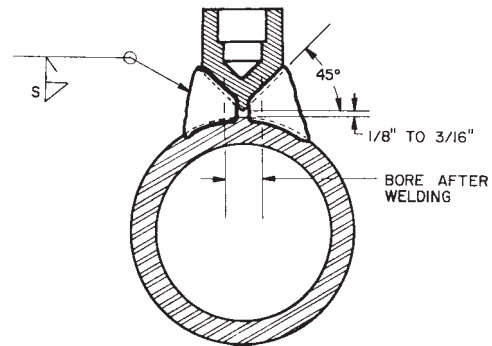

1/8 in. = 3 mm
 3/16 in. = 5 mm

Application—Class I and II piping.
 System or Service—All.

- Remarks—1. Reinforcing fillet S shall have a minimum throat dimension of 1/4 in. (6 mm).

FIG. 29 Fillet Reinforced Boss Conn Without Pilot, Single Bevel

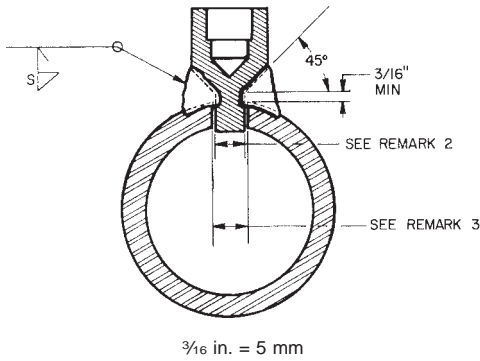

Application—Class I and II piping.
System or Service—All.

- Remarks—1. Reinforcing fillet S shall have a minimum throat dimension of 1/4 in. (6 mm).
2. Pilot hole shall be 1/32 in. (1 mm) larger than pilot diameter.
3. Final bore after welding shall be a minimum of 1/8 in. (3 mm) larger than pilot diameter.

FIG. 30 Fillet Reinforced Boss Conn with Pilot, Single Bevel

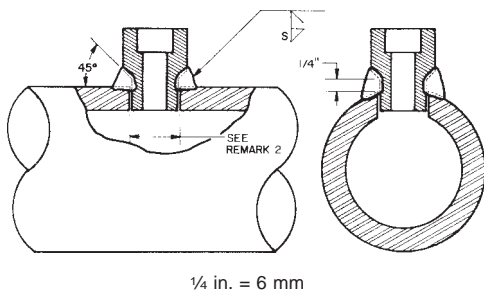

Application—Class I and II piping 2-in. NPS max.

System or Service—All, provided pressure does not exceed 1025 psi (7067 kPa) max or temperature does not exceed 750°F (399°C) max.

- Remarks—1. Reinforcing fillet S shall have a minimum throat dimension of 1/4 in. (6 mm).
2. Pilot hole diameter shall be equal to backing ring OD plus 1/32 in. (1 mm).

FIG. 31 Fillet Reinforced Boss Conn (Couplet) with Integral Backing Ring

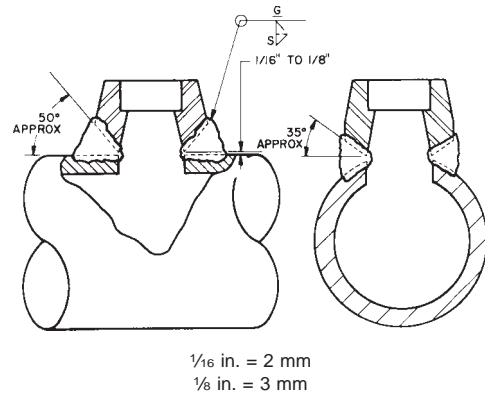

Application—Class II piping.

System or Service—All, provided root of weld is visually inspected where possible to ensure complete weld penetration.

- Remarks—1. Reinforcing fillet S shall have a minimum throat dimension of 1/4 in. (6 mm).
2. For services such as vents, overflows, and gravity drains (including plumbing), the root of the weld need not be ground.

FIG. 32 Fillet Reinforced External Root Conn, Single Bevel with Integrally Reinforced Outlet

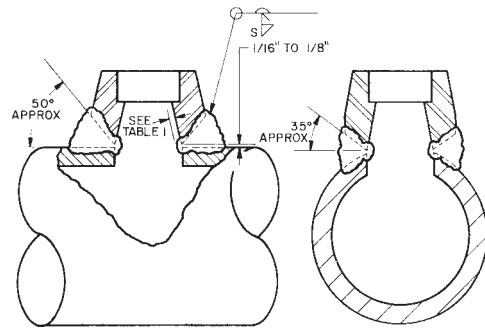

Application—Class I and II piping.

System or Service—All.

- Remarks—1. Reinforcing fillet S shall have a minimum throat dimension of 1/4 in. (6 mm).
2. Internal weld shall be made first and ground, chipped, or cleaned by some other means to assure sound welds.

FIG. 33 Fillet Reinforced External Root Conn Welded Both Sides, Single Bevel with Integrally Reinforced Outlet

 **F 722 – 82 (1998)**

ASTM International takes no position respecting the validity of any patent rights asserted in connection with any item mentioned in this standard. Users of this standard are expressly advised that determination of the validity of any such patent rights, and the risk of infringement of such rights, are entirely their own responsibility.

This standard is subject to revision at any time by the responsible technical committee and must be reviewed every five years and if not revised, either reapproved or withdrawn. Your comments are invited either for revision of this standard or for additional standards and should be addressed to ASTM International Headquarters. Your comments will receive careful consideration at a meeting of the responsible technical committee, which you may attend. If you feel that your comments have not received a fair hearing you should make your views known to the ASTM Committee on Standards, at the address shown below.

This standard is copyrighted by ASTM International, 100 Barr Harbor Drive, PO Box C700, West Conshohocken, PA 19428-2959, United States. Individual reprints (single or multiple copies) of this standard may be obtained by contacting ASTM at the above address or at 610-832-9585 (phone), 610-832-9555 (fax), or service@astm.org (e-mail); or through the ASTM website (www.astm.org).