



Standard Specification for Suction Strainer Boxes¹

This standard is issued under the fixed designation F 986; the number immediately following the designation indicates the year of original adoption or, in the case of revision, the year of last revision. A number in parentheses indicates the year of last approval. A superscript epsilon (ϵ) indicates an editorial change since the last revision or reapproval.

1. Scope

1.1 This specification covers the design, materials, and construction of strainer boxes for use in ships' bilges and other such tank locations that require trash protection for suction pipes and pumps.

1.2 This specification covers pipe sizes from NPS 1½ through NPS 16 (see Note 1).

NOTE 1—The dimensionless designator NPS (nominal pipe size) has been substituted in this specification for such traditional terms as “nominal diameter,” “size,” and “nominal size.”

1.3 The values stated in inch-pound units are to be regarded as the standard.

2. Referenced Documents

2.1 ASTM Standards:

A 36/A36M Specification for Carbon Structural Steel²

A 123/A 123M Specification for Zinc (Hot-Dip Galvanized) Coatings on Iron and Steel Products³

F 593 Specification for Stainless Steel Bolts, Hex Cap Screws, and Studs⁴

F 594 Specification for Stainless Steel Nuts⁴

F 708 Practice for Design and Installation of Rigid Pipe Hangers⁵

2.2 American Welding Society Standard:

AWS D1.3 Structural Welding Code—Sheet Steel⁶

3. Classification

3.1 This specification covers two types of strainer boxes.

3.1.1 *Type 1*—Strainer boxes with pipe clamp centered on the top of the strainer box (see Fig. 1).

3.1.2 *Type 2*—Strainer boxes with the pipe clamp off center in the top of the strainer box (see Fig. 2).

4. Ordering Information

4.1 Ordering information required is as follows.

4.1.1 ASTM specification and year of issue.

4.1.2 Type.

4.1.3 Size (suction pipe NPS).

4.1.4 Dimensions *G* and *H* (*Type 2* only).

4.1.5 Number of each type and size.

5. Materials and Manufacture

5.1 For information on materials, see Table 1.

5.2 Welding shall be in accordance with AWS D1.3.

5.3 Perforated sheet metal shall have ⅜-in. diameter holes on staggered ½-in. centers, 51 % open area.

6. Dimensions and Tolerances

6.1 *Tolerance*— $\pm 1/16$ in.

6.2 *Strainer Box Dimensions*:

6.2.1 *Type 1*—See Table 2.

6.2.2 *Type 2*—See Table 3.

7. Workmanship, Finish, and Appearance

7.1 Strainer boxes shall be hot galvanized in accordance with Specification A 123/A 123M after fabrication. The galvanizing shall be a minimum of 2 mils thick.

7.2 Strainer boxes shall be free of defects, burrs, and sharp edges.

8. Installation

8.1 Strainer boxes are normally installed on suction pipes in ballast and bilge spaces.

8.2 Minimum suction pipe or tank bottom clearances are indicated in Column “F” in Table 2 and Table 3. Dimension callout is based on ½ × the tailpipe nominal pipe size.

8.3 Tank structure and sloping bottom structure may obscure the above clearance down to the limit of the resulting periphery clear area, being 1.5 × the inside diameter of the tailpipe. Structure outside the limit of ½ the pipe NPS need not be considered as obstructing flow.

¹ This specification is under the jurisdiction of ASTM Committee F25 on Ships and Marine Technology and is the direct responsibility of Subcommittee F25.11 on Machinery and Piping Systems.

Current edition approved March 27, 1986. Published May 1986.

² *Annual Book of ASTM Standards*, Vol 01.04.

³ *Annual Book of ASTM Standards*, Vol 01.06.

⁴ *Annual Book of ASTM Standards*, Vol 15.08.

⁵ *Annual Book of ASTM Standards*, Vol 01.07.

⁶ Available from American Welding Society, 550 NW LeJeune Rd., Miami, FL 33126.

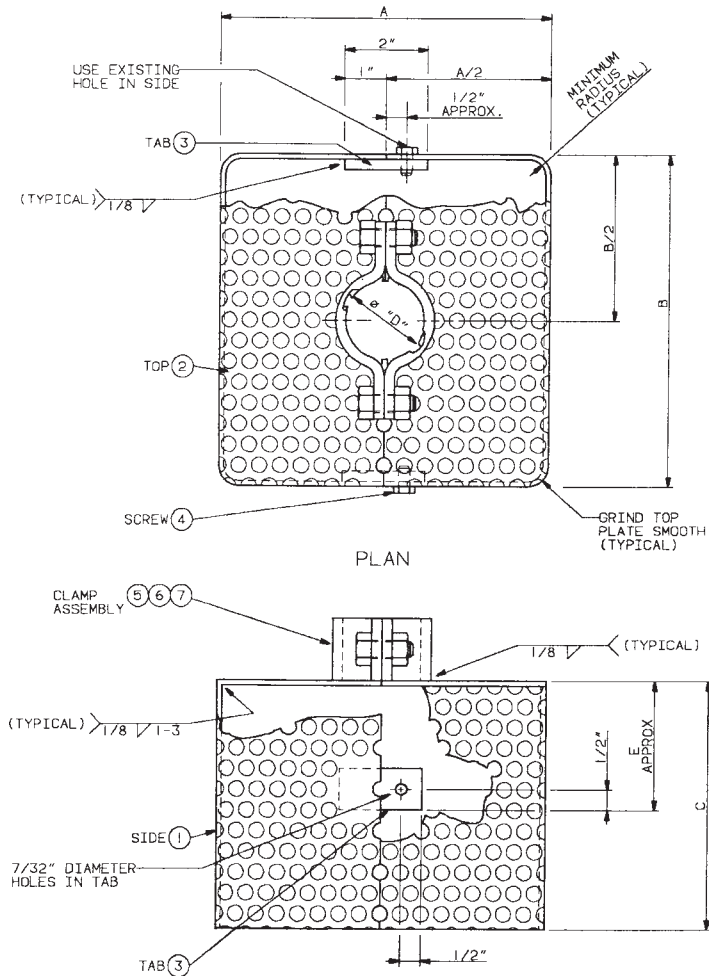

NOTE 1—Tab location to suit perforated holes.

FIG. 1 Type 1—Elevation Strainer Box

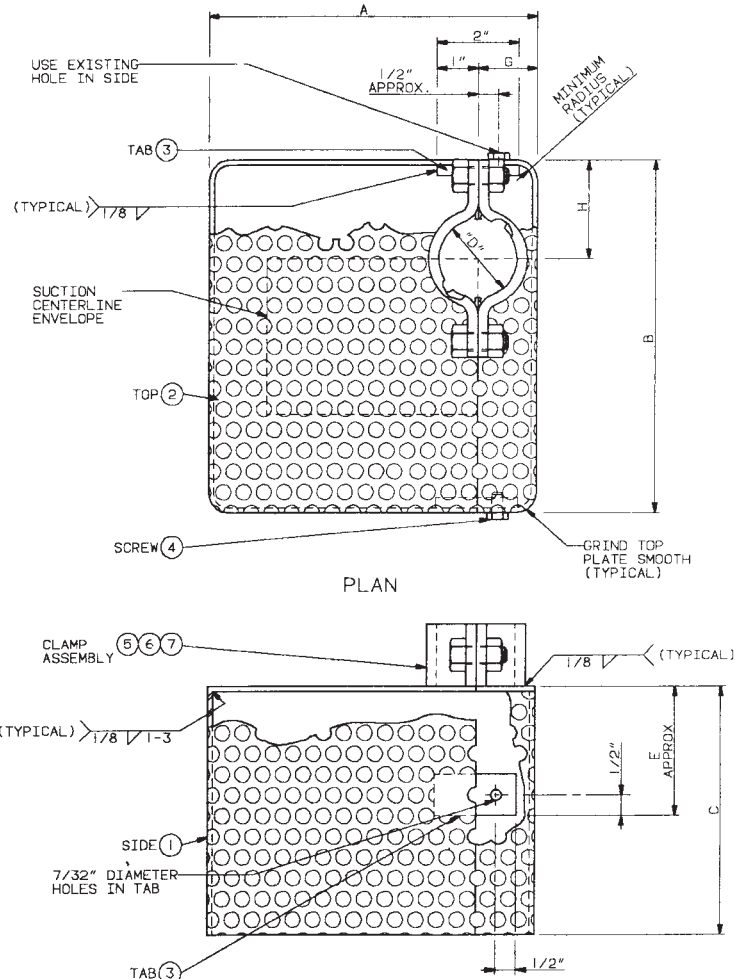
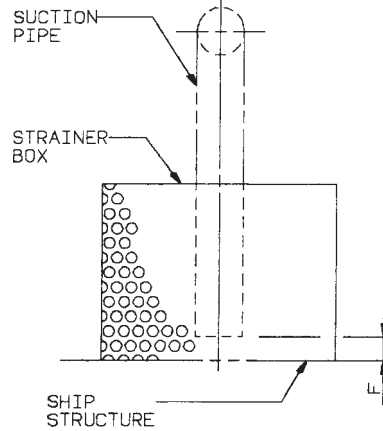

FIG. 2 Type 2—Elevation Rectangular Strainer

TABLE 1 Parts List

Item Number	Description
1	<i>Side</i> —Sheet metal, 11 gage, perforated 3/8-in. diameter holes staggered on 1/2-in. centers, carbon steel, Specification A 36/A 36M.
2	<i>Top</i> —Sheet metal, 11 gage, perforated 3/8-in. diameter holes staggered on 1/2-in. centers, carbon steel, Specification A 36/A 36M.
3	<i>Tab</i> —Flatbar, 1/4 in. thick × 1 in. wide × 2 in. long, carbon steel, Specification A 36/A 36M or ABS Grade A.
4	<i>Screw</i> —Tapping, plain hexagon washer head 1/4 nominal size × 3/4 in. long, Type 316 stainless steel, Specification F 593.
5	<i>Clamp</i> —Split cap, Practice F 708 Fig. 1a, without standoff.
6	<i>Bolt</i> —Hexagon head, stainless steel, Type 316 Specification F 593. Size in accordance with Practice F 708.
7	<i>Nut</i> —Hexagon heavy, stainless steel, Type 316 Specification F 594. Size in accordance with Practice F 708.

TABLE 2 Type 1 Strainer Dimensions



Flat Surface Installation

Suction Pipe NPS	A	B	C	D	E	F ^A	Weight, lb
	Strainer Side Width, in.	Strainer Length, in.	Strainer Height, in.	Hole Diameter, in.	Tab Location, in.	Pipe Clearance, in.	
1½	8	8	6	1 ⁵ / ₁₆	3	¾	7.3
2	8	8	6	2 ⁷ / ₁₆	3	1	7.5
2½	8	8	6	2 ¹⁵ / ₁₆	3	1¼	8.4
3	14	14	6	3 ⁹ / ₁₆	3	1½	14.3
4	14	14	6	4 ⁹ / ₁₆	3	2	14.9
5	20	20	6	5 ⁵ / ₈	3	2½	22.8
6	20	20	6	6 ¹ / ₁₆	3	3	25.5
8	26	26	8	8 ¹ / ₁₆	4	4	40.2
10	32	32	10	10 ³ / ₁₆	5	5	61.3
12	38	38	12	12 ¹³ / ₁₆	6	6	83.4
14	42	42	14	14 ¹ / ₁₆	4 and 10	7	106.2
16	48	48	16	16 ¹ / ₁₆	5 and 11	8	134.8

^ASee 8.2 and 8.3 of this specification.

TABLE 3 Type 2 Strainer Dimensions

Suction Pipe (NPS)	A ^A	B ^A	Perimeter, min, in. ^A	C	D	E	F	G ^B	H
	Width, min, in.	Length, min, in.		Height, in.	Hole Diameter, in.	Tab Location, in.	Pipe Clearance, in.	Side Width, min, in.	Side Length, min, in.
1½	2 ⁷ / ₈	4¾	20	6	1 ⁵ / ₁₆	3	¾	1 ⁷ / ₁₆	2 ³ / ₈
2	3 ³ / ₈	6 ¹ / ₈	25	6	2 ⁷ / ₁₆	3	1	1 ¹¹ / ₁₆	3 ¹ / ₁₆
2½	3 ⁵ / ₈	6 ⁷ / ₈	31	6	2 ¹⁵ / ₁₆	3	1¼	1 ¹⁵ / ₁₆	3 ⁷ / ₁₆
3	4 ³ / ₈	7¾	38	6	3 ⁹ / ₁₆	3	1½	2 ³ / ₁₆	3 ⁷ / ₈
4	5 ³ / ₈	9 ³ / ₈	49	6	4 ⁹ / ₁₆	3	2	2 ¹¹ / ₁₆	4 ¹ / ₁₆
5	6½	10 ¹⁵ / ₁₆	62	6	5 ⁵ / ₈	3	2½	3¼	5½
6	8	12	74	6	6 ¹ / ₁₆	3	3	4	6
8	10	14½	99	8	8 ¹ / ₁₆	4	4	5	7¼
10	12¼	16 ⁵ / ₈	123	10	10 ³ / ₁₆	5	5	6 ¹ / ₈	8 ⁵ / ₁₆
12	14¼	19 ³ / ₈	147	12	12 ¹³ / ₁₆	6	6	7 ¹ / ₈	9 ¹¹ / ₁₆
14	15 ³ / ₈	20 ⁵ / ₈	162	14	14 ¹ / ₁₆	4 and 10	7	7 ¹¹ / ₁₆	10 ⁹ / ₁₆
16	17 ³ / ₈	22 ⁵ / ₈	184	16	16 ¹ / ₁₆	5 and 11	8	8 ¹¹ / ₁₆	11 ⁵ / ₁₆

^AMinimum dimensions A and B are independent of one another and relate only to required clearances for the clamp assembly and suction requirements. The total minimum perimeter for the box is shown in the undesignated fourth column.

^BSee 8.2 and 8.3 of this specification.

 **F 986 – 86 (1997)**

ASTM International takes no position respecting the validity of any patent rights asserted in connection with any item mentioned in this standard. Users of this standard are expressly advised that determination of the validity of any such patent rights, and the risk of infringement of such rights, are entirely their own responsibility.

This standard is subject to revision at any time by the responsible technical committee and must be reviewed every five years and if not revised, either reapproved or withdrawn. Your comments are invited either for revision of this standard or for additional standards and should be addressed to ASTM International Headquarters. Your comments will receive careful consideration at a meeting of the responsible technical committee, which you may attend. If you feel that your comments have not received a fair hearing you should make your views known to the ASTM Committee on Standards, at the address shown below.

This standard is copyrighted by ASTM International, 100 Barr Harbor Drive, PO Box C700, West Conshohocken, PA 19428-2959, United States. Individual reprints (single or multiple copies) of this standard may be obtained by contacting ASTM at the above address or at 610-832-9585 (phone), 610-832-9555 (fax), or service@astm.org (e-mail); or through the ASTM website (www.astm.org).