



Designation: **F 987 – 9304**

An American National Standard

## Standard Specification for Portable Intermediate Flush Deck Stanchion<sup>1</sup>

This standard is issued under the fixed designation F 987; the number immediately following the designation indicates the year of original adoption or, in the case of revision, the year of last revision. A number in parentheses indicates the year of last reapproval. A superscript epsilon ( $\epsilon$ ) indicates an editorial change since the last revision or reapproval.

### 1. Scope

1.1 This specification covers the design, construction, and installation of intermediate portable flush deck stanchions. Intermediate stanchion is defined as any stanchion that is not an end or corner stanchion.

1.2 Stanchions shall be used on interior and exterior decks, to provide temporary protection to minimize the danger of personnel falling overboard or to a lower level in the ship in areas where the installation of a fixed system would interfere with vessel operations.

1.3 Stanchions may be used with  ~~$\frac{3}{8}$~~   $\frac{3}{8}$ -in. (9.5-mm) galvanized close link chain or wire rope lifelines  $\frac{9}{16}$ -in. (14-mm) top course,  $\frac{7}{16}$ -in. (11-mm) lower courses.

1.4 ~~This standard specification~~ covers only the stanchions and does not cover requirements for the chain or wire rope lines to be supported by the stanchion.

1.5 The values stated in inch-pound units are to be regarded as the standard.

<sup>1</sup> This specification is under the jurisdiction of ASTM Committee F25 on Shipbuilding Ships and Marine Technology and is the direct responsibility of Subcommittee F25.03 on Outfitting and Deck Machinery.

Current edition approved ~~March 15, 1993~~; Mar. 1, 2004. Published ~~May 1993~~; March 2004. Originally published as F 987 – 86; approved in 1986. Last previous edition approved in 1993 as F 987 – ~~86~~93.

## 2. Referenced Documents

### 2.1 *ASTM Standards:*<sup>2</sup>

A 106 Specification for Seamless Carbon Steel Pipe for High-Temperature Service

A 123/A 123M Specification for Zinc (Hot-Dip Galvanized) Coatings on Iron and Steel Products

A 182/A 182M Specification for Forged or Rolled Alloy-Steel Pipe Flanges, Forged Fittings, and Valves and Parts for High-Temperature Service

F 783 Specification for Staple, Handgrab, Handle, and Stirrup Rung

### 2.2 *ANSI/ASME Standards:*

B 16.11 Forged Steel Fittings, Socket-Welding, and Threaded<sup>3</sup>

B 16.15 Cast Bronze Threaded Fittings<sup>3</sup>

### 2.3 *ANSI/AWS Standard:*

D 1.1 Structure Welding Code<sup>3</sup>

### 2.4 *Code of Federal Regulations:*

Title 46 Shipping, Parts 70 to 89, Subpart 72.40<sup>4</sup>

## 3. Classification

3.1 Portable flush deck stanchions shall be available in two types:

3.1.1 *Type I*—Two-course portable flush deck stanchions (see Fig. 1).

3.1.2 *Type II*—Three-course portable flush deck stanchions (see Fig. 2).

## 4. Ordering Information

4.1 Orders for portable flush deck stanchions under this specification shall include the following information:

4.1.1 ASTM designation and year of issue (that is, F 987 – 04).

4.1.2 Type.

4.1.3 Quantity.

4.1.4 ~~Special requirements.~~

4.1.4 If socket plug stowage coupling is required.

4.2 Lifelines shall be ordered separately.

## 5. Materials and Manufacture

### 5.1 *Materials:*

5.1.1 Pipe for stanchion shall be in accordance with Specification A 106, Grade A or B, NPS 1½, Schedule 80, carbon steel.

5.1.2 Staple shall be in accordance with Specification F 783, Table 1, Type II.

5.1.3 Socket shall be in accordance with Specification A 182/A 182M, ANSI B 16.11, NPS 1½, 3000 lb, Type 316L, stainless steel (1½-6 UNC-2B).

5.1.4 Socket plug shall be in accordance with ANSI B 16.15, NPS 1½, Bronze-Threaded Class 250, countersunk square head (1½-6 UNC-2B).

### 5.2 *Manufacture:*

5.2.1 Welding shall be as shown on Figs. 1-3 and shall be in accordance with ANSI/AWS D1.1.

5.2.2 Stanchion assembly, excluding socket and socket plug, shall be hot-galvanized in accordance with Specification A 123/A 123M.

## 6. Other Requirements

6.1 Stanchions shall be installed in accordance with contact requirements or as specified below:

6.1.1 Portable flush deck stanchions shall not be used on inclined ladders.

6.1.2 *Type I Stanchions*—Required on bridges, platforms, walkways, and elsewhere as needed in accordance with 46 CFR (see 3.1).

6.1.3 *Type II Stanchions*—Required along the exposed peripheries of freeboards, weather decks and superstructure decks in accordance with 46 CFR ~~and ABS rules~~ (see 3.1).

## 7. Installation

7.1 The intended installation is to follow these general guidelines:

<sup>2</sup> For referenced ASTM standards, visit the ASTM website, [www.astm.org](http://www.astm.org), or contact ASTM Customer Service at [service@astm.org](mailto:service@astm.org). For *Annual Book of ASTM Standards*, Vol 01.01, volume information, refer to the standard's Document Summary page on the ASTM website.

*Annual Book of ASTM*

<sup>3</sup> Available from American National Standards, Vol 01.06: Institute (ANSI), 25 W. 43rd St., 4th Floor, New York, NY 10036.

*Annual Book*

<sup>4</sup> Available from U.S. Government Printing Office Superintendent of ~~ASTM Standards~~, Vol 01.07: Documents, 732 N. Capitol St., NW, Mail Stop: SDE, Washington, DC 20401.

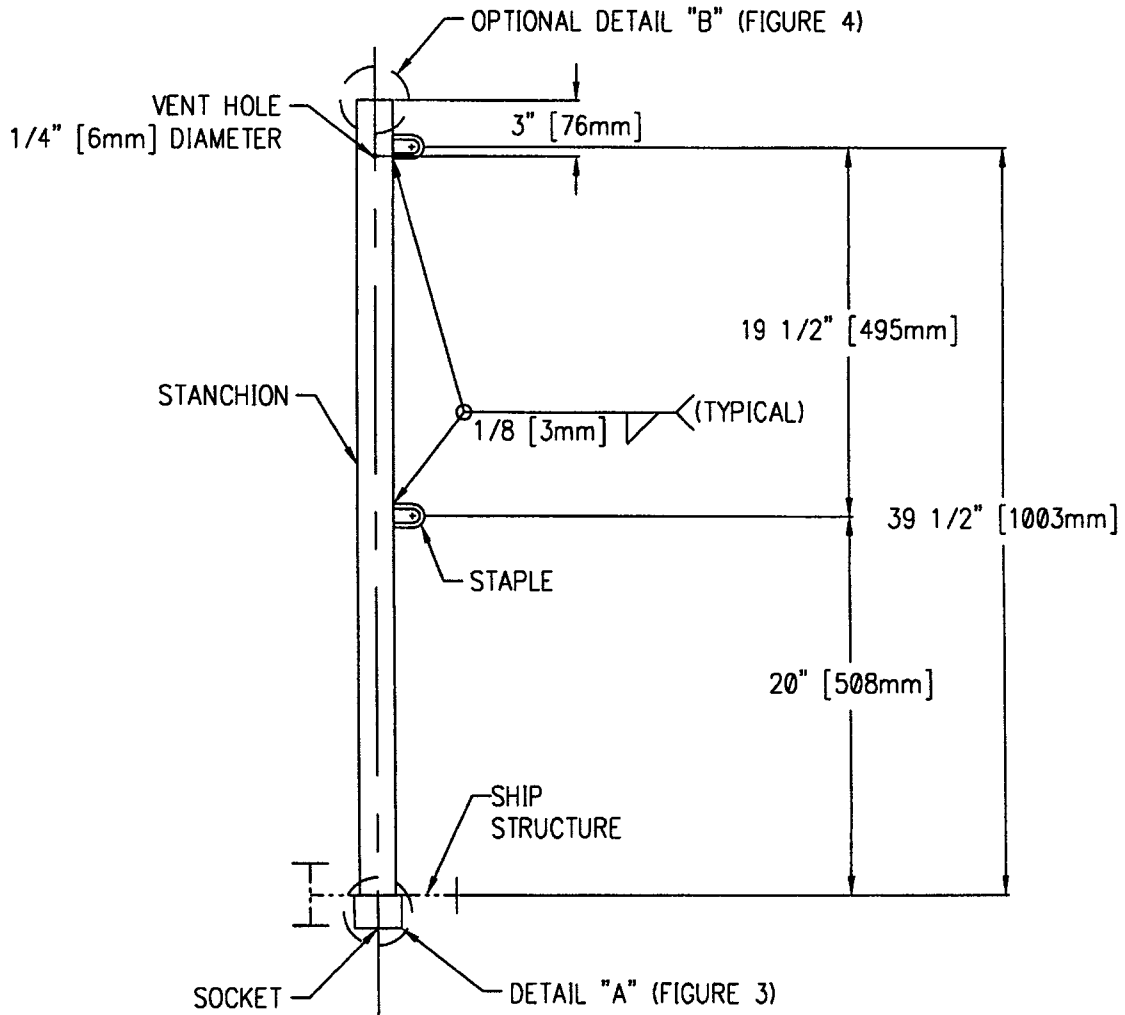

FIG. 1 Type I—Two Course Portable Flush Deck Stanchion

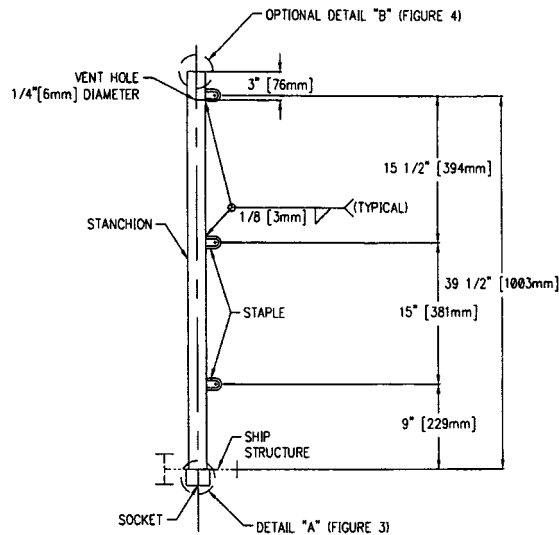

FIG. 2 Type II—Three Course Portable Flush Deck Stanchion

- 7.1.1 There shall be a maximum clearance of 4 in. (101.6 mm) between stanchion centerline and other structure.
- 7.1.2 Sockets shall be installed and aligned so that stanchions are perpendicular to the ship's baseline.
- 7.1.3 Stanchions shall be installed with 10 ft (3050 mm) maximum between centers; 6 ft (1830 mm) minimum.
- 7.1.4 Socket plugs shall be provided for installation in deck when stanchions ~~is stowed and in the~~ are stowed.

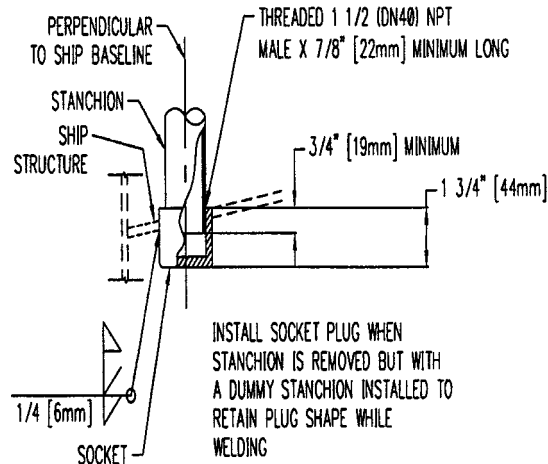

FIG. 3 Detail "A"

7.1.5 The top of stanchions may be provided with a coupling for stowage of socket plugs when stanchions are in use. See Fig. 4.

## 8. Dimensions and Tolerances

8.1 *Dimensions for Type I*—Two course portable flush deck stanchions shall be in accordance with Fig. 1.

8.2 *Dimensions for Type II*—Three course portable flush deck stanchions shall be in accordance with Fig. 2.

8.3 The dimensions are as indicated. To determine the metric equivalents, multiply the inch dimension by 25.4 mm.

8.4 Tolerances indicated.

8.4 Socket, socket plug, stanchion, and coupling shall have tolerances in accordance with ANSI B16.15. All other dimensions shall have a tolerance of  $\pm 1/4$  in. (6.35 mm).

## 9. Workmanship, Finish, and Appearance

9.1 Stanchions shall be free of weld spatter, slag splinters, sharp edges, burrs, projections, and other defects hazardous to personnel.

9.2 Galvanizing destroyed after fabrication shall be repaired by the application of cold-galvanizing compound.

## 10. Testing

10.1 Hammer test deck sockets for soundness and strength.

10.2 Apply static concentrated load of 300 lb

10.2 Test at least one stanchion head outboard at 90° to the lifeline and hold for a period of 10 min. After release of the load, the stanchion assembly shall not exhibit any visible defects each platform or loosening deck by application of joints due to having had the test a load applied. Test at least 10% (minimum horizontally in accordance with the methods in "Strength and Stiffness of Metal Railing Systems and Rails for Buildings."<sup>5</sup>

<sup>6</sup> Available from American National Standards Institute, 11 W. 42nd St., 13th Floor, New York, NY 10036.

<sup>5</sup> "Strength and Stiffness of Metal Railing Systems and Rails for Buildings," *Journal of Testing and Evaluation*, ASTM International, Vol 16, No. 2, March 1988, pp. 214-221.

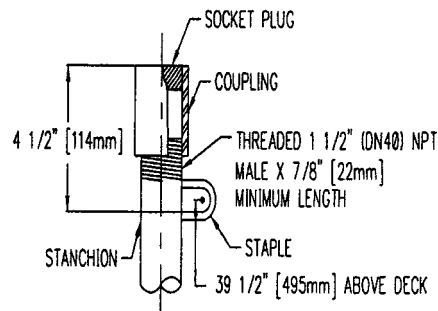

FIG. 4 Detail "B"

**11. Packaging**

11.1 Loose hardware shall be packaged and wired to stanchion.

**12. Keywords**

12.1 deck stanchions; portable intermediate flush deck stanchion; stanchions

*ASTM International takes no position respecting the validity of any patent rights asserted in connection with any item mentioned in this standard. Users of this standard are expressly advised that determination of the validity of any such patent rights, and the risk of infringement of such rights, are entirely their own responsibility.*

*This standard is subject to revision at any time by the responsible technical committee and must be reviewed every five years and if not revised, either reapproved or withdrawn. Your comments are invited either for revision of this standard or for additional standards and should be addressed to ASTM International Headquarters. Your comments will receive careful consideration at a meeting of the responsible technical committee, which you may attend. If you feel that your comments have not received a fair hearing you should make your views known to the ASTM Committee on Standards, at the address shown below.*

*This standard is copyrighted by ASTM International, 100 Barr Harbor Drive, PO Box C700, West Conshohocken, PA 19428-2959, United States. Individual reprints (single or multiple copies) of this standard may be obtained by contacting ASTM at the above address or at 610-832-9585 (phone), 610-832-9555 (fax), or [service@astm.org](mailto:service@astm.org) (e-mail); or through the ASTM website ([www.astm.org](http://www.astm.org)).*