



Standard Specification for Design and Installation of Overboard Discharge Hull Penetration Connections¹

This standard is issued under the fixed designation F 994; the number immediately following the designation indicates the year of original adoption or, in the case of revision, the year of last revision. A number in parentheses indicates the year of last reapproval. A superscript epsilon (ε) indicates an editorial change since the last revision or reapproval.

1. Scope

1.1 This specification covers carbon steel overboard discharge hull penetrations for system piping of NPS 1 through NPS 24 (see Note 1).

NOTE 1—The dimensionless designator NPS (nominal pipe size) has been substituted in this standard for such TRADITIONAL terms as nominal diameter, size, and nominal size.

1.2 The minimum pipe schedule and reinforcement dimensions presented in Tables 1-6 are based on specifications in 46 CFR, 56.50-95 and Navy Design Data Sheet 100-1.

1.3 This specification does not include sea chest penetrations.

1.4 This specification does not include penetrations in protective plating.

2. Referenced Documents

2.1 ASTM Standards:

A 519 Specification for Seamless Carbon and Alloy Steel Mechanical Tubing²

2.2 ANSI Standard:

B36.10 Welded and Seamless Wrought Steel Pipe³

2.3 Military Document:

MIL-STD-1689 Fabrication, Welding, and Inspection of Ships Structure⁴

2.4 Other Documents:

Title 46 Code of Federal Regulations (CFR), Subchapter F, Marine Engineering⁴

Department of the Navy, Bureau of Ship Design Data Sheet 100-1⁵

¹ This specification is under the jurisdiction of ASTM Committee F25 on Ships and Marine Technology and is the direct responsibility of Subcommittee F25.11 on Machinery and Piping Systems.

Current edition approved March 27, 1986. Published June 1986.

² Annual Book of ASTM Standards, Vol 01.01.

³ Available from American National Standards Institute, 25 W. 43rd St., 4th Floor, New York, NY 10036.

⁴ Available from Superintendent of Documents, U.S. Government Printing Office, Washington, DC 20402.

⁵ Available from Department of the Navy, Naval Sea Systems Command, Washington, DC 20362.

TABLE 1 Pipe Schedule for Type 1 Penetrations, NPS 1 Through NPS 24^A

Penetration Pipe Size, NPS	Shell Plating Thickness (T), in.									
	¼-½	⅝	¾	7/8	1	1 1/8	1 ¼	1 ⅝	1 ¾	2
1	80	80	160	160	160	160	XXS	XXS	XXS	XXS
1 ¼	80	160	160	160	XXS	XXS	XXS	XXS	XXS	XXS
1 ½	80	160	160	160	160	XXS	XXS	XXS	XXS	XXS
2	80	160	160	160	160	160	160	XXS	XXS	XXS
2 ½	80	80	160	160	160	160	160	XXS	XXS	XXS
3	80	80	160	160	160	160	160	160	160	XXS
4	80	80	120	120	120	120	120	160	160	160
5	80	80	80	120	120	120	120	120	160	160
6	80	80	80	120	120	120	120	120	120	160
8	80	80	80	80	100	100	100	100	120	120
10	60	60	60	80	80	100	100	100	100	120
12	60	60	60	80	80	80	100	100	100	100
14	60	60	60	80	80	80	80	100	100	100
16	40	60	60	60	80	80	80	80	80	100
18	40	40	60	60	60	80	80	80	80	80
20	40	40	60	60	60	60	80	80	80	80
22	40	40	60	60	60	60	60	80	80	80
24	40	40	60	60	60	60	60	60	60	80

^ASee Fig. 1.

ABS Rules for Building and Classing Steel Vessels⁶

3. Classification

3.1 *Type I*—Nonreinforced penetrations. Table 1 provides minimum schedules for the penetration pipe. See Fig. 1 for details of the penetration.

3.2 *Type II*—Doubler plate-reinforced penetrations. Table 2 provides minimum dimensions for doubler plates.

3.2.1 *Class 1*—Inboard doubler plates. (Fig. 2)

3.2.2 *Class 2*—Outboard doubler plates. (Fig. 3)

3.3 *Type III*—Insert plate-reinforced penetrations. Table 3 provides minimum dimensions for insert plates.

3.3.1 *Class 1*—Single-bevel insert plates. (Fig. 4)

3.3.2 *Class 2*—Double-bevel insert plates. (Fig. 5)

3.4 *Type IV*—Sleeve-reinforced penetrations. Fig. 6 details sleeve-reinforced penetrations.

⁶ Available from American Bureau of Shipping, ABS Plaza, 16855 Northchase Dr., Houston, TX 77060.

TABLE 2 Doubler Plate Dimensions ($T_D \times D$) Type II Penetration, NPS 1 Through NPS 24 (in. \times in.)^A

Penetrating Pipe Size, NPS, SCH	Shell Plating Thickness (T), in.								
	¼ to ½	⅝	¾	⅞	1	1⅛	1¼	1⅝	1½
1, 80	¼ × 5	⅝ × 5	½ × 5	⅞ × 5	¾ × 5	¾ × 5	1 × 5	1 × 5	1¼ × 5
1¼, 80	¼ × 6	⅝ × 6	½ × 6	⅞ × 6	¾ × 6	¾ × 6	1 × 6	1 × 6	1¼ × 6
1½, 80	¼ × 6	⅝ × 6	½ × 6	⅞ × 6	¾ × 6	¾ × 6	1 × 6	1 × 6	1¼ × 6
2, 80	¼ × 7	⅝ × 7	½ × 7	⅞ × 7	¾ × 7	¾ × 7	1 × 7	1 × 7	1¼ × 7
2½, 80	¼ × 7	⅝ × 7	½ × 7	⅞ × 7	¾ × 7	¾ × 7	1 × 7	1 × 7	1¼ × 7
3, 80	¼ × 8	⅝ × 8	½ × 8	⅞ × 8	¾ × 8	¾ × 8	1 × 8	1 × 8	1¼ × 8
4, 80	¼ × 9	⅝ × 9	½ × 9	⅞ × 9	¾ × 9	¾ × 9	1 × 9	1 × 9	1¼ × 9
5, 80	¼ × 10	⅝ × 10	½ × 10	⅞ × 10	¾ × 10	¾ × 10	1 × 10	1 × 10	1¼ × 10
6, 80	¼ × 12	⅝ × 12	½ × 12	⅞ × 12	¾ × 12	¾ × 12	1 × 12	1 × 12	1¼ × 12
8, 80	¼ × 14	⅝ × 14	½ × 14	⅞ × 14	¾ × 14	¾ × 14	1 × 14	1 × 14	1¼ × 14
10, 60	¼ × 16	⅝ × 16	½ × 16	⅞ × 16	¾ × 16	¾ × 16	1 × 16	1 × 16	1¼ × 16
12, 60	¼ × 18	⅝ × 18	½ × 18	⅞ × 18	¾ × 18	¾ × 18	1 × 18	1 × 18	1¼ × 18
14, 60	¼ × 20	⅝ × 20	½ × 20	⅞ × 20	¾ × 20	¾ × 20	1 × 20	1 × 20	1¼ × 20
16, 40	¼ × 22	⅝ × 22	½ × 22	⅞ × 22	¾ × 22	¾ × 23	1 × 22	1 × 23	1¼ × 24
18, 40	¼ × 24	⅝ × 24	½ × 24	⅞ × 24	¾ × 24	¾ × 25	1 × 24	1 × 25	1¼ × 28
20, 40	¼ × 26	⅝ × 26	½ × 26	⅞ × 26	¾ × 26	¾ × 27	1 × 26	1 × 27	1¼ × 30
22, 60	¼ × 28	⅝ × 28	½ × 28	⅞ × 28	¾ × 28	¾ × 29	1 × 28	1 × 29	1¼ × 32
24, 40	¼ × 30	⅝ × 30	½ × 30	⅞ × 30	¾ × 30	¾ × 31	1 × 30	1 × 31	1¼ × 33

^ASee Fig. 2 and Fig. 3.

TABLE 3 Insert Plate Dimensions ($T_I \times D$), NPS 1 Through NPS 24 (in. \times in.)^A

Penetrating Pipe Size, NPS, SCH	Shell Plating Thickness (T), in.								
	¼ to ½	⅝	¾	⅞	1	1⅛	1¼	1⅝	1½
1, 80	1 × 8	1⅝ × 8¼	1¼ × 8½	1⅞ × 8¾	1½ × 9	1⅞ × 9¼	1¾ × 9½	1⅞ × 9¾	2 × 10
1¼, 80	1 × 8¼	1⅝ × 8½	1¼ × 8¾	1⅞ × 9	1½ × 9¼	1⅞ × 9½	1¾ × 10	1⅞ × 10¼	2 × 10½
1½, 80	1 × 8¾	1⅝ × 8¾	1¼ × 9	1⅞ × 9¼	1½ × 9½	1⅞ × 10	1¾ × 10	1⅞ × 10½	2 × 10¾
2, 80	1 × 9	1⅝ × 9¼	1¼ × 9½	1⅞ × 9¾	1½ × 10	1⅞ × 10¼	1¾ × 10½	1⅞ × 11	2 × 11
2½, 80	1 × 10	1⅝ × 10	1¼ × 10	1⅞ × 10¼	1½ × 10½	1⅞ × 10¾	1¾ × 11	1⅞ × 11¼	2 × 11½
3, 80	1 × 10½	1⅝ × 10¾	1¼ × 10¾	1⅞ × 11	1½ × 11¼	1⅞ × 11½	1¾ × 11¾	1⅞ × 12	2 × 12¼
4, 80	1 × 11	1⅝ × 11½	1¼ × 11¾	1⅞ × 12	1½ × 12¼	1⅞ × 12½	1¾ × 12¾	1⅞ × 13	2 × 13¼
5, 80	1 × 12	1⅝ × 12½	1¼ × 13	1⅞ × 13	1½ × 13¼	1⅞ × 13½	1¾ × 13¾	1⅞ × 14	2⅞ × 15
6, 80	1 × 13	1⅝ × 13½	1¼ × 14	1⅞ × 14	1½ × 14¼	1⅞ × 14½	1¾ × 14¾	1⅞ × 15	2⅞ × 16¼
8, 80	1 × 14	1⅝ × 14½	1¼ × 15	1⅞ × 16	1½ × 16¼	1⅞ × 16½	1¾ × 17	2 × 18	2½ × 19¼
10, 60	1 × 16	1⅝ × 17	1¼ × 18	1⅞ × 18¼	1½ × 18½	1⅞ × 18¾	2 × 20¾	2⅞ × 22¾	2¼ × 23
12, 60	1 × 18	1⅝ × 18½	1¼ × 19	1⅞ × 20	1½ × 20½	1⅞ × 20¾	2 × 22¾	2⅞ × 24¾	2½ × 25
14, 60	1 × 21	1⅝ × 21	1¼ × 21	1⅞ × 21½	1½ × 21¾	1⅞ × 22	2 × 24	2⅞ × 26	2⅞ × 25¾
16, 40	1 × 23	1⅝ × 23	1¼ × 23¼	1⅞ × 24¼	1¾ × 26½	2⅞ × 27½	2⅞ × 28½	2⅞ × 29¾	2⅞ × 31
18, 40	1 × 25	1⅝ × 25	1¼ × 25¼	1⅞ × 25½	1¾ × 27½	2⅞ × 29½	2⅞ × 30½	2⅞ × 31¾	2⅞ × 33
20, 40	1 × 27	1⅝ × 27¼	1¼ × 27¼	1⅞ × 28¼	1⅞ × 30½	2⅞ × 31½	2⅞ × 32½	2⅞ × 33¾	2⅞ × 35
22, 60	1 × 29	1⅝ × 29	1¼ × 29	1⅞ × 30	1⅞ × 30	2⅞ × 30	2⅞ × 33½	2⅞ × 34½	2⅞ × 36
24, 40	1 × 31	1⅝ × 31	1¼ × 31¼	1⅞ × 31½	1⅞ × 34½	2⅞ × 35½	2⅞ × 36½	2⅞ × 38	2⅞ × 39

^ASee Fig. 4 and Fig. 5.

3.4.1 *Class 1*—Sleeves of nonmachined steel tube. Table 4 provides minimum dimensions for nonmachined sleeves.

3.4.2 *Class 2*—Sleeves of machined steel tube or pipe. Table 5 provides minimum dimensions for machined sleeves.

3.4.3 *Class 3*—Sleeves of rolled steel flatbar or plate. Table 6 provides minimum dimensions for rolled sleeves.

4. Materials

4.1 Discharge pipe shall be of an acceptable material as specified by Title 46 CFR, 56.60-1.

4.2 Doubler and insert plates shall be of material with physical properties equal to or better than the reinforced shell plate.

4.3 Reinforcing sleeve material shall depend on the penetration pipe size:

Penetration Pipe Size	Sleeve Material
NPS 1 through NPS 10	Seamless Steel Tubing, Specification A 519.
NPS 12 through NPS 18	Machined seamless steel pipe of same material as penetration pipe.
NPS 20 through NPS 24	Steel flatbar or plate of same or superior material as hull plate, manufactured with a full penetration, longitudinal butt weld.

5. General Requirements

5.1 Overboard discharges shall be combined to the maximum extent practicable to minimize the number of shell penetrations.

5.2 A minimum of 3 in. shall be maintained between the edge of penetrations and shell plate welding seams. Penetrations shall be located so as to provide sufficient space for



TABLE 4 Reinforcing Sleeve Dimensions, NPS 1 Through NPS 5 (Seamless Steel Tubing)^A

Penetration Pipe Size, NPS, SCH	Sleeve Size, in.	Shell Plating Thickness (T), in.								
		¼ – ½	⅝	¾	⅞	1	1⅛	1¼	1⅜	1½
1, 80	outer diameter	1⅞	1⅞	1⅞	2⅞	2⅞	2⅞	2⅞	2⅞	2⅞
	wall thickness	¼	¼	¼	⅜	⅜	⅜	⅜	⅜	⅜
	length	1¾	1⅞	2	2⅞	2¼	2⅜	2½	2⅝	3
1¼, 80	outer diameter	2¼	2¼	2¼	2¼	3	3	3	3	3
	wall thickness	⅝	⅝	⅝	⅝	⅝	⅝	⅝	⅝	⅝
	length	1¾	1⅞	2	2⅞	2¼	2⅜	2½	2⅝	2¾
1½, 80	outer diameter	2½	2½	2½	3	3	3	3	3	3
	wall thickness	⅝	⅝	⅝	⅞	⅞	⅞	⅞	⅞	⅞
	length	1¾	1⅞	2	2⅞	2¼	2⅜	2½	2⅝	3
2, 80	outer diameter	3⅞	3⅞	3⅞	3⅞	4	4	4	4	4
	wall thickness	⅝	⅝	⅝	⅝	¾	¾	¾	¾	¾
	length	1¾	1⅞	2¼	2½	2¼	2⅜	2½	2⅝	2¾
2½, 80	outer diameter	4	4	4	4	4	4	4	4	4
	wall thickness	½	½	½	½	½	½	½	½	½
	length	1¾	1⅞	2	2⅞	2½	2⅜	3	3½	3⅝
3, 80	outer diameter	4½	4½	4½	4½	4½	4½	4⅝	4⅝	4⅝
	wall thickness	⅞	⅞	⅞	⅞	⅞	⅞	½	½	½
	length	1¾	1⅞	2¼	2½	3	3⅜	3½	3¾	4⅞
4, 80	outer diameter	6¼	6¼	6¼	6¼	6¼	6¼	6¼	6¼	6¼
	wall thickness	⅞	⅞	⅞	⅞	⅞	⅞	⅞	⅞	⅞
	length	1¾	1⅞	2	2⅞	2½	2⅜	3	3¼	3½
5, 80	outer diameter	6⅝	7⅝	7⅝	7⅝	7⅝	8	8⅝	8⅝	8⅝
	wall thickness	½	1	1	1	1	1⅜	1½	1½	1½
	length	2	2	2	2⅞	2½	2½	2½	2¾	3

^ASee Fig. 6.

TABLE 5 Reinforcing Sleeve Dimensions, NPS 6 Through NPS 12 (Machined Seamless Steel Tube)^A

Penetration Pipe Size, NPS, SCH	Sleeve Size, in.	Shell Plating Thickness (T), in.								
		¼–½	⅝	¾	⅞	1	1⅛	1¼	1⅜	1½
6, 80	tube outer diameter	8½	8½	8½	8½	9	9	9½	9½	10
	machined inner diameter	6¾	6¾	6¾	6¾	6¾	6¾	6¾	6¾	6¾
	length	1¾	2	2¼	2½	2½	2¾	2¾	3	3
8, 80	tube outer diameter	10	10	10½	10½	11	11	11½	11½	12
	machined inner diameter	8¾	8¾	8¾	8¾	8¾	8¾	8¾	8¾	8¾
	length	2¼	2¾	2¾	3	3	3¼	3¼	3½	3½
10, 60	tube outer diameter	12	12	12½	12¾	13⅜	13⅜	13⅜	14	14
	machined inner diameter	10⅞	10⅞	10⅞	10⅞	10⅞	10⅞	10⅞	10⅞	10⅞
	length	2¾	3¼	3¼	3¼	3¼	3¼	3¾	3¾	4
12, 60	tube outer diameter	14	14⅜	14⅜	15	15	16	16	16	16
	machined inner diameter	12⅞	12⅞	12⅞	12⅞	12⅞	12⅞	12⅞	12⅞	12⅞
	length	3	3	3½	3½	3¾	3¾	3½	3¾	4¼

^ASee Fig. 6.

welding between the penetration and shell longitudinals, stiffeners, or other structural members.

5.3 Shell penetrations located above the light load line shall be clear of side ports, accommodation ladders, lifeboat-handling areas, or other areas where discharge overboard is detrimental to normal operation of the vessel or would create a nuisance for personnel or other vessels in the area.

5.4 Overboard discharges shall be located to minimize recirculation into suction seachests.

5.5 Shell penetrations shall be located outside of cathodic protection areas.

5.6 Unfavorable flow characteristics may result when small diameter, extreme schedule penetration pipe is used in accordance with Table 1. In this case, minimum allowable schedule

penetration pipe, with necessary reinforcement as specified in Tables 2-6, is suggested.

5.7 Penetration pipe extension past the shell plate shall be equal to the pipe wall thickness but not more than ⅜ in.

6. Welding

6.1 Welding shall be in accordance with Figs. 1-6 (see also ANSI B36.10).

6.2 Weld quality shall be in accordance with American Bureau of Shipping standards.

6.3 Fillet welds shall be equal to the penetration pipe wall thickness but not more than ⅜ in.

6.4 Weld quality for military vessels shall be in accordance with MIL-STD-1689.

TABLE 6 Reinforcing Sleeve Dimensions, NPS 14 Through NPS 24 (Rolled Steel Flatbar or Plate)^A

Penetration Pipe Size, NPS, SCH	Sleeve Size, in.	Shell Plating Thickness (T), in.								
		1/4 – 1/2	5/8	3/4	7/8	1	1 1/8	1 1/4	1 3/8	1 1/2
14, 60	inner diameter	14 3/16	14 3/16	14 3/16	14 3/16	14 3/16	14 3/16	14 3/16	14 3/16	14 3/16
	wall thickness	3/4								
	length	2 1/2	3/4	3/4	1	1	1 1/4	1 1/4	1 1/2	1 1/2
16, 40	inner diameter	16 3/16	16 3/16	16 3/16	16 3/16	16 3/16	16 3/16	16 3/16	16 3/16	16 3/16
	wall thickness	3/4								
	length	2 3/4	3/4	3/4	1	1	1 1/4	1 1/4	1 1/2	1 1/2
18, 40	inner diameter	18 3/16	18 3/16	18 3/16	18 3/16	18 3/16	18 3/16	18 3/16	18 3/16	18 3/16
	wall thickness	3/4								
	length	3	3/4	3/4	1	1	1 1/4	1 1/4	1 1/2	1 1/2
20, 40	inner diameter	20 3/16	20 3/16	20 3/16	20 3/16	20 3/16	20 3/16	20 3/16	20 3/16	20 3/16
	wall thickness	3/4								
	length	3 1/2	3/4	3/4	1	1	1 1/4	1 1/4	1 1/2	1 1/2
22, 60	inner diameter	22 3/16	22 3/16	22 3/16	22 3/16	22 3/16	22 3/16	22 3/16	22 3/16	22 3/16
	wall thickness	3/4								
	length	3 1/2	3/4	3/4	1	1	1 1/4	1 1/4	1 1/2	1 1/2
24, 40	inner diameter	24 3/16	24 3/16	24 3/16	24 3/16	24 3/16	24 3/16	24 3/16	24 3/16	24 3/16
	wall thickness	3/4								
	length	3 3/4	3/4	3/4	1	1	1 1/4	1 1/4	1 1/2	1 1/2
			4 3/4	5 1/2	5 1/2	5 3/4	5 3/4	6	6	6 1/4

^ASee Fig. 6.

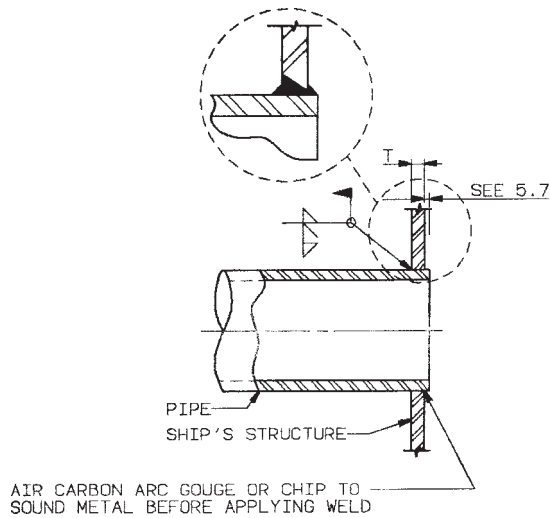

FIG. 1 Type I: Penetration

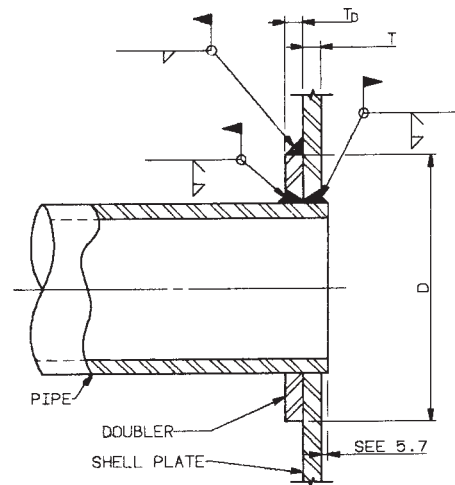

FIG. 2 Type II, Class 1 Penetration: Inboard Doubler Plate

7. Workmanship, Finish, and Appearance

7.1 Surface areas, corners, and discharge pipe ends shall be free of burrs and sharp edges.

8. Keywords

8.1 discharge hull penetration; hull penetration; marine technology; penetration connection; ships; system piping

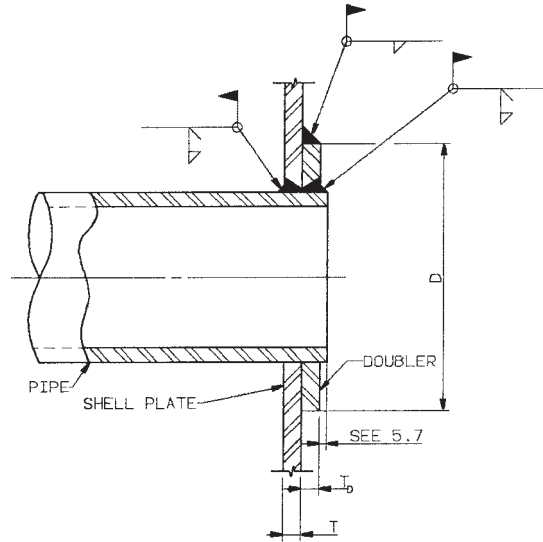

FIG. 3 Type II, Class 2 Penetration: Outboard Doubler Plate

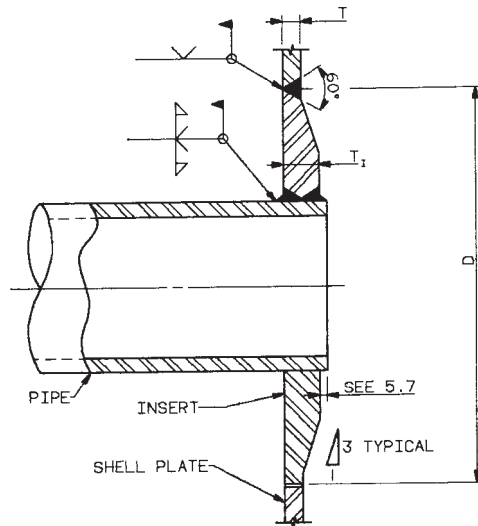

FIG. 4 Type III, Class 1 Penetration: Single-Bevel Insert Plate

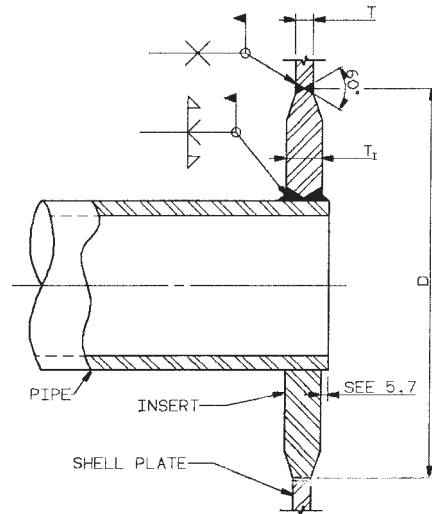

FIG. 5 Type III, Class 2 Penetration: Double-Bevel Insert Plate

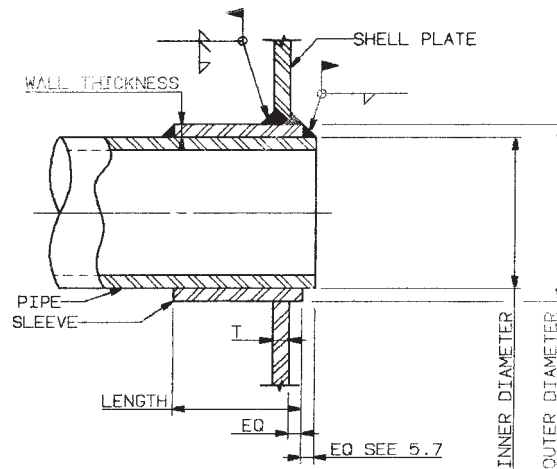

FIG. 6 Type IV Penetration: Reinforcing Sleeve

ASTM International takes no position respecting the validity of any patent rights asserted in connection with any item mentioned in this standard. Users of this standard are expressly advised that determination of the validity of any such patent rights, and the risk of infringement of such rights, are entirely their own responsibility.

This standard is subject to revision at any time by the responsible technical committee and must be reviewed every five years and if not revised, either reapproved or withdrawn. Your comments are invited either for revision of this standard or for additional standards and should be addressed to ASTM International Headquarters. Your comments will receive careful consideration at a meeting of the responsible technical committee, which you may attend. If you feel that your comments have not received a fair hearing you should make your views known to the ASTM Committee on Standards, at the address shown below.

This standard is copyrighted by ASTM International, 100 Barr Harbor Drive, PO Box C700, West Conshohocken, PA 19428-2959, United States. Individual reprints (single or multiple copies) of this standard may be obtained by contacting ASTM at the above address or at 610-832-9585 (phone), 610-832-9555 (fax), or service@astm.org (e-mail); or through the ASTM website (www.astm.org).