



Standard Specification for Copper-Nickel Alloy Castings¹

This standard is issued under the fixed designation B 369; the number immediately following the designation indicates the year of original adoption or, in the case of revision, the year of last revision. A number in parentheses indicates the year of last reapproval. A superscript epsilon (ϵ) indicates an editorial change since the last revision or reapproval.

This standard has been approved for use by agencies of the Department of Defense.

1. Scope*

1.1 This specification covers requirements for copper-nickel alloy castings whose nominal compositions are shown in Table 1. These are as follows:²

Copper Alloy UNS No. ²	Previous Designation
C96200	Alloy A
C96400	Alloy B

1.2 Castings of these alloys are used primarily for corrosion-resisting purposes in both constructional and pressure applications and particularly in marine pumps, valves, and fittings.

1.3 These alloys are considered weldable, but they may be ordered with a weld test to ensure weldability. When extensive welding is to be performed on the casting, weldability tests should be specified in the ordering information (4.2.6) to ensure proper welding characteristics.

1.4 The values stated in inch-pound units are to be regarded as the standard. The values given in parentheses are provided for information purposes only.

1.5 This hazard statement applies only to Section 6, Weldability Test, of this specification. *This standard does not purport to address all of the safety concerns, if any, associated with its use. It is the responsibility of the user of this standard to establish appropriate safety and health practices and determine the applicability of regulatory limitations prior to use.*

2. Referenced Documents

2.1 ASTM Standards:

B 208 Practice for Preparing Tension Test Specimens for Copper Alloys for Sand, Permanent Mold, Centrifugal and Continuous Castings³

B 824 Specification for General Requirements for Copper Alloy Castings³

B 846 Terminology for Copper and Copper Alloys³

E 527 Practice for Numbering Metals and Alloys (UNS)⁴

2.2 ASME Code:

ASME Boiler and Pressure Vessel Code⁵

2.3 AWS Standard:

AWS A5.6 Specification for Copper and Copper-Alloy Arc-Welding Electrodes⁶

3. Terminology

3.1 Definitions of terms relating to copper alloys can be found in Terminology B 846.

4. Ordering Information

4.1 Orders for castings under this specification should include the following information:

4.1.1 Specification title, number, and year of issue,

4.1.2 Quantity of castings,

4.1.3 Copper Alloy UNS Number (Table 2),

4.1.4 Pattern or drawing number and condition (as-cast, machined, and so forth),

4.1.5 ASME Boiler and Pressure Vessel Code Requirements (Section 11),

4.1.6 When material is purchased for agencies of the U.S. Government, the Supplementary Requirements of this specification may be specified.

4.2 The following are optional and should be specified in the purchase order when required:

4.2.1 Pressure test or soundness requirements (Specification B 824),

4.2.2 Witness inspection (Specification B 824),

4.2.3 Certification (Specification B 824),

4.2.4 Foundry test report (Specification B 824),

4.2.5 Product marking (Specification B 824),

4.2.6 Weldability test (1.3 and Section 6), and

4.2.7 Approval of weld procedure and records of repairs (Section 10).

¹ This specification is under the jurisdiction of ASTM Committee B05 on Copper and Copper Alloys and is the direct responsibility of Subcommittee B05.05 on Castings and Ingots for Remelting.

Current edition approved Apr. 10, 2003. Published June 2003. Originally approved in 1961. Last previous edition approved in 1996 as B 369 – 96.

² The UNS system for copper and copper alloys (see Practice E 527) is a simple expansion of the former standard designation system accomplished by the addition of a prefix “C” and a suffix “00”. The suffix can be used to accommodate composition variations of the base alloy.

³ *Annual Book of ASTM Standards*, Vol 02.01.

⁴ *Annual Book of ASTM Standards*, Vol 01.01.

⁵ Available from American Society of Mechanical Engineers (ASME), ASME International Headquarters, Three Park Ave., New York, NY 10016-5990.

⁶ Available from The American Welding Society (AWS), 550 NW LeJeune Rd., Miami, FL 33126.

*A Summary of Changes section appears at the end of this standard.

TABLE 1 Nominal Compositions

Copper Alloy UNS No.	Composition, %					
	Copper	Nickel	Iron	Silicon	Manganese	Niobium
C96200	87.5	10.0	1.5	0.1	0.9	...
C96400	67.0	30.0	0.7	0.5	0.8	1.0

TABLE 2 Chemical Requirements

	Copper Alloy UNS No. C96200		Copper Alloy UNS No. C96400	
	Min, %	Max, %	Min, %	Max, %
Copper	balance		balance	
Lead	...	0.01	...	0.01
Iron	1.0	1.8	0.25	1.5
Nickel, incl cobalt	9.0	11.0	28.0	32.0
Manganese	...	1.5	...	1.5
Silicon	...	0.50	...	0.50
Niobium	...	1.0	0.50	1.5
Phosphorus	...	0.02	...	0.02
Sulfur	...	0.02	...	0.02
Carbon	...	0.10	...	0.15

TABLE 4 Metric Conversion Values for Figs. 1 and 2

in.	mm	in.	mm
1/8	3.18	1 3/4	44.4
3/8	9.52	2 3/4	69.8
3/4	19.0	3	76.2
1	25.4	3 1/2	88.9
1 1/8	28.6	6	152

5. Chemical Composition

5.1 The castings shall conform to the chemical requirements shown in Table 2 for the copper alloy UNS numbers specified in the purchase order.

5.2 These specification limits do not preclude the presence of other elements. Limits may be established and analysis required for unnamed elements agreed upon between the manufacturer or supplier and the purchaser. Copper may be given as remainder and may be taken as the difference between the sum of all elements analyzed and 100 %. When all the elements in the table are analyzed, their sum shall be 99.5 % minimum.

6. Mechanical Properties

6.1 Mechanical properties shall be determined from separately cast test bar castings, and shall meet the requirements shown in Table 3.

7. Weldability Test

7.1 When specified in the purchase order at least one test cast as shown in Fig. 1 shall be prepared for each lot of welding grade castings (4.2.6).

7.2 The block shall be molded, gated, and risered in a manner to produce a sound casting without defects that might interfere with welding or the interpretation of the results of the test.

7.3 The groove in the test block shall be completely filled with weld deposit metal, using the manual metallic-arc process with 1/8 -in. (12.7-mm) or 5/32 -in. (3.97-mm) diameter copper-

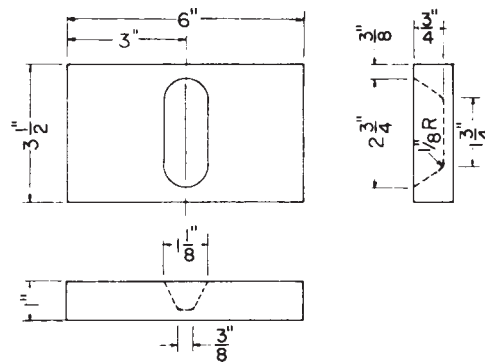

NOTE 1—For metric equivalents see Table 4.

FIG. 1 Cast Block for Weldability Test

nickel (70-30) coated electrodes conforming to classification AWS ECuNi of AWS Specification A5.6. The interpass temperature need not be controlled, unless it is to be controlled in fabrication.

7.4 One 3/8 -in. (9.52-mm) minimum thick bend coupon (see Fig. 2), shall be removed longitudinally from the center of the welded block by machining, sawing, abrasive cutting, or other suitable means. Cut surfaces and edges should be sanded smooth if necessary. The side bend specimen then shall be bent 180° in a guided bend jig around a mandrel 1 1/2 in. (38.1 mm) in diameter with the weld located at the center of the bend.

7.5 Cracks or other open defects exceeding 1/8 in. measured in any direction in the fusion zone or heat-affected zone on the

TABLE 3 Mechanical Requirements

	Copper Alloy UNS No. C96200	Copper Alloy UNS No. C96400
Tensile strength, min, ksi ^A (MPa)	45 (310)	60 (415)
Yield strength, ^B min, ksi ^A (MPa)	25 (170)	32 (220)
Elongation in 2 in. (50.8 mm), %	20	20

^A ksi = 1000 psi.

^B Yield strength shall be determined as the stress producing an elongation under load of 0.5 %, that is 0.01 in. (0.254 mm) in a gage length of 2 in. (50.8 mm).

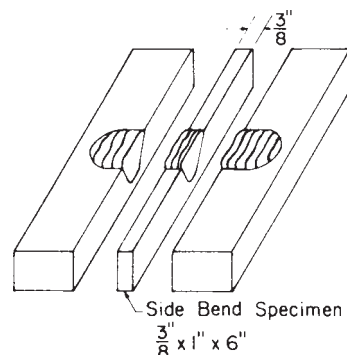

NOTE 1—For metric equivalents see Table 4.

FIG. 2 Weldability Test Block

convex surface of the specimen after bending shall be cause for rejection. Cracks originating at weld-bead undercuts, at weld-slag inclusions, or at casting defects shall not be cause for rejection.

8. Casting Repair

8.1 Alloys included in this specification are generally weldable. Weld repairs may be made at the manufacturer's discretion provided each excavation does not exceed 20 % of the casting section or wall thickness or 4 % of the casting surface area.

8.2 Excavations that exceed those described in 7.1 may be made at the manufacturer's discretion except that when specified in the purchase order (9.1.11) the weld procedure shall be approved by the purchaser and the following record shall be maintained:

8.2.1 A sketch or drawing showing the dimensions, depth, and location of excavations,

8.2.2 Post weld heat treatment, when applicable,

8.2.3 Weld repair inspection results,

8.2.4 Casting identification number,

8.2.5 Weld procedure identification number,

8.2.6 Welder identification, and

8.2.7 Name of inspector.

8.3 The castings shall not be impregnated without approval of the purchaser.

9. General Requirements

9.1 The following sections of Specification B 824 form a part of this specification. In the event of a conflict between this specification and Specification B 824, the requirements of this specification shall take precedence.

9.1.1 Terminology (Section 3),

9.1.2 Other Requirements (Section 5),

9.1.3 Dimensions, Mass, and Permissible Variations (Section 6),

9.1.4 Workmanship, Finish, and Appearance (Section 7),

9.1.5 Sampling (Section 8),

9.1.6 Number of Tests and Retests (Section 10),

9.1.7 Specimen Preparation (Section 11),

9.1.8 Test Methods (Section 12),

9.1.9 Significance of Numerical Limits (Section 13),

9.1.10 Inspection (Section 14),

9.1.11 Rejection and Rehearing (Section 15),

9.1.12 Certification (Section 16),

9.1.13 Test Report (Section 17),

9.1.14 Product Marking (Section 18), and

9.1.15 Packaging and Package Marking (Section 19).

10. Sampling

10.1 Test bar castings for the copper alloy UNS numbers in this specification shall be cast to the form and dimensions shown in Fig. 1 or Fig. 2 of Practice B 208.

11. Test Methods

11.1 Analytical chemical methods are given in Specification B 824.

11.1.1 Test methods to be followed for the determination of elements resulting from contractual or purchase order agreement shall be as agreed upon between the manufacturer or supplier and the purchaser.

12. ASME Requirements

12.1 When specified in the purchase order to meet ASME Boiler and Pressure Vessel Code requirements, castings in copper alloy UNS No. C96200 shall comply with the following:

12.1.1 Certification requirements of Specification B 824.

12.1.2 Foundry test report requirements of Specification B 824.

12.1.3 Castings shall be marked with the manufacturer's name, the copper alloy UNS number, and the casting quality factor. In addition, heat numbers or serial numbers that are traceable to heat numbers shall be marked on all pressure-containing castings individually weighing 50 lb (22.7 kg) or more. Pressure-containing castings weighing less than 50 lb (22.7 kg) shall be marked with either the heat number or a serial number that will identify the casting as to the month in which it was poured. Marking shall be in such a position as to not injure the usefulness of the casting.

13. Keywords

13.1 copper-alloy castings; copper-nickel castings

SUPPLEMENTARY REQUIREMENTS

The following supplementary requirements shall apply only when specified by the purchaser in the inquiry, contract, or order, for agencies of the U.S. government.

S1. Referenced Documents

S1.1 The following documents of the issue in effect on date of material purchase form a part of this specification to the extent referenced herein:

S1.1.1 *Federal Standards*:⁷

Fed. Std. No. 102 Preservation, Packaging, and Packing Levels

Fed. Std. No. 123 Marking for Shipment (Civil Agencies)

Fed. Std. No. 185 Identification Marking of Copper and Copper-Base Alloy Mill Products

S1.1.2 *Military Standards*:⁷

MIL-STD-129 Marking for Shipment and Storage

MIL-STD-248 Welded and Brazing Procedure in Performance Qualification

⁷ Standardization Documents Order Desk, Bldg. 4 Section D, 700 Robbins Ave., Philadelphia, PA 19111-5094 Attn: NPODS.

MIL-STD-278 Welding and Casting Standard

S1.1.3 *Military Specification.*⁷

MIL-C-3993 Packaging of Copper and Copper-Base Alloy Mill Products

S2. Soundness

S2.1 Castings shall meet the soundness requirements of MIL-STD-278 for the category, sub-category, and criticality level specified in the purchase order.

S3. Pressure Test

S3.1 Castings shall meet the pressure test requirements of MIL-STD-278.

S4. Weld Repair

S4.1 All repair welding shall be in accordance with MIL-STD-278 using welders and welding procedures qualified in accordance with MIL-STD-248.

S5. Quality Assurance

S5.1 *Responsibility for Inspection:*

S5.1.1 Unless otherwise specified in the contract or purchase order, the manufacturer is responsible for the performance of all inspection and test requirements specified. Except as otherwise specified in the contract or purchase order, the manufacturer may use his own or any other suitable facilities for the performance of the inspection and test requirements unless disapproved by the purchaser at the time the order is

placed. The purchaser shall have the right to perform any of the inspections or tests set forth when such inspections and tests are deemed necessary to ensure that the material conforms to prescribed requirements.

S6. Product Marking

S6.1 The castings shall be permanently marked in accordance with MIL-STD-792 and include specification and alloy number, pattern or drawing number, lot number, and manufacturer's name or trademark.

S7. Preparation for Delivery

S7.1 *Preservation, Packaging, and Packing:*

S7.1.1 *Military Agencies*—The material shall be separated by size, composition, grade, or class and shall be preserved and packaged, Level A or C, packed, Level A, B, or C as specified in the contract or purchase order, in accordance with the requirements of MIL-C-3993.

S7.1.2 *Civil Agencies*—The requirements of Fed. Std. No. 102 shall be referenced for definitions of the various levels of packaging protection.

S7.2 *Marking:*

S7.2.1 *Military Agencies*—In addition to any special marking required by the contract or purchase order, marking for shipment shall be in accordance with MIL-STD-129.

S7.2.2 *Civil Agencies*—In addition to any special marking required by the contract or purchase order, marking for shipment shall be in accordance with Fed. Std. No. 123.

SUMMARY OF CHANGES

Committee B05 has identified the location of selected changes to this standard since the last issue (B 369 – 95) that may impact the use of this standard.

- (1) Section 3, Terminology, was added.
- (2) Sections 9 and 4 were revised.
- (3) Sections 10, Test Methods, and 11, ASME Requirements, were added.

- (4) The niobium content of copper alloy UNS No. C96200 was changed from 0.50–1.0 % to 1.0 % max.

ASTM International takes no position respecting the validity of any patent rights asserted in connection with any item mentioned in this standard. Users of this standard are expressly advised that determination of the validity of any such patent rights, and the risk of infringement of such rights, are entirely their own responsibility.

This standard is subject to revision at any time by the responsible technical committee and must be reviewed every five years and if not revised, either reapproved or withdrawn. Your comments are invited either for revision of this standard or for additional standards and should be addressed to ASTM International Headquarters. Your comments will receive careful consideration at a meeting of the responsible technical committee, which you may attend. If you feel that your comments have not received a fair hearing you should make your views known to the ASTM Committee on Standards, at the address shown below.

This standard is copyrighted by ASTM International, 100 Barr Harbor Drive, PO Box C700, West Conshohocken, PA 19428-2959, United States. Individual reprints (single or multiple copies) of this standard may be obtained by contacting ASTM at the above address or at 610-832-9585 (phone), 610-832-9555 (fax), or service@astm.org (e-mail); or through the ASTM website (www.astm.org).