

This document is not an ASTM standard and is intended only to provide the user of an ASTM standard an indication of what changes have been made to the previous version. Because it may not be technically possible to adequately depict all changes accurately, ASTM recommends that users consult prior editions as appropriate. In all cases only the current version of the standard as published by ASTM is to be considered the official document.



Designation: E 1114 – 92 (Reapproved 1997)^{ε1}



Standard Test Method for Determining the Focal Size of Iridium-192 Industrial Radiographic Sources¹

This standard is issued under the fixed designation E 1114; the number immediately following the designation indicates the year of original adoption or, in the case of revision, the year of last revision. A number in parentheses indicates the year of last reapproval. A superscript epsilon (ϵ) indicates an editorial change since the last revision or reapproval.

~~^{ε1} NOTE—Section 10 was added editorially in February 1997.~~

¹ This test method is under the jurisdiction of ASTM Committee ~~E-7~~ E07 on Nondestructive Testing and is the direct responsibility of Subcommittee E07.01 on Radiographic Practice Radiology (X and Penetrators—Gamma) Method.

Current edition approved ~~Sept. 15, 1992; March 10, 2003.~~ Published ~~November 1992; May 2003.~~ Originally published as E1114–86; approved in 1986. Last previous edition approved in 1997 as E 1114 – 8692 (1997)^{ε1}.

1. Scope

1.1 This test method covers the determination of the focal size of an iridium-192 radiographic source. The determination is based upon measurement of the image of the iridium metal source in a projection radiograph of the source assembly and comparison to the measurement of the image of a reference sample in the same radiograph.

1.2 *This standard does not purport to address all of the safety concerns, if any, associated with its use. It is the responsibility of the user of this standard to establish appropriate safety and health practices and determine the applicability of regulatory limitations prior to use.*

2. Referenced Documents

2.1 ASTM Standards:

E 999 Guide for Controlling the Quality of Industrial Radiographic Film Processing²

E 1316 Terminology for Nondestructive Examinations²

E 1815 Test Method for Classification of Film Systems for Industrial Radiography²

3. Terminology

3.1 For definitions of terms relating to this test method, refer to Terminology E 1316.

4. Significance and Use

4.1 One of the factors affecting the quality of a radiographic image is geometric unsharpness. The degree of geometric unsharpness is dependent upon the focal size of the source, the distance between the source and the object to be radiographed, and the distance between the object to be radiographed and the film. This test method allows the user to determine the focal size of the source and to use this result to establish source to object and object to film distances appropriate for maintaining the desired degree of geometric unsharpness.

5. Apparatus

5.1 *Subject Iridium-192 Source*, the focal size of which is to be determined. The appropriate apparatus and equipment for the safe storage, handling, and manipulation of the subject source, such as a radiographic exposure device (also referred to as a gamma ray projector or camera), remote control, source guide tube, and source stop are also required.

5.2 *Reference Sample* (see Figs. 1-3)—The reference sample shall be of material which is not radioactive. The recommended material is iridium. However, substitutes such as platinum, tungsten or other material of similar radiopacity may be used. The sample should be of the same geometric shape as the subject source, should be approximately the same size as the subject source, and should be positioned on or within a shim or envelope to simulate the source capsule wall. The resulting radiographic contrast, with reference to adjacent background density of the image of the reference sample, should be approximately the same as that of the subject source. The actual dimensions of the reference sample should be determined to the nearest 0.025 mm (0.001 in.).

5.3 *X-ray Generator*, capable of producing a radiation intensity (roentgen per hour at one metre) at least ten times greater than that produced by the subject source. Examples of typical X-ray generator output requirements that satisfy this criterion are presented in Table 1.

² Annual Book of ASTM Standards, Vol 03.03.

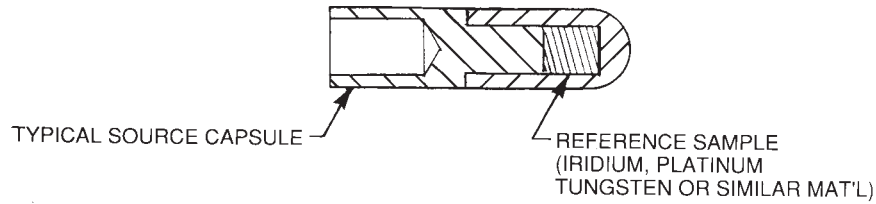

FIG. 1 Reference Sample in Standard Source Encapsulation

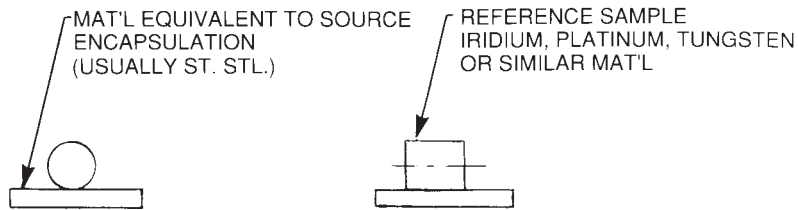
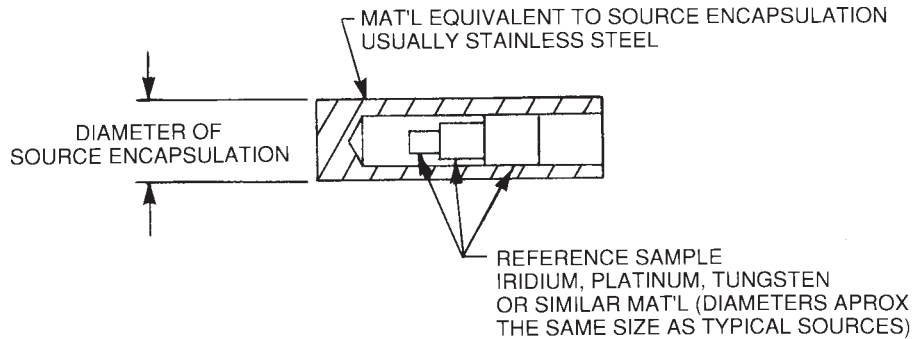

FIG. 2 Alternate Reference Sample Arrangement

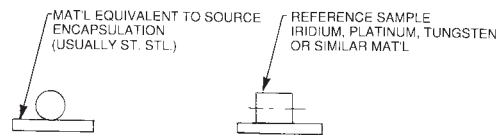

FIG. 3 Alternate Reference Sample Arrangement

5.4 ~~Film, industrial type fine grain, extra fine grain, systems~~— Only film systems having cognizant engineering organization approval or ultra fine grain as defined by meeting the film manufacturer system class requirements of Test Method E 1815, for system classes I, II or Special, shall be used. Selection of film type systems should be determined by such factors as the required radiographic quality level, equipment capability, materials; and so forth. The film system selected ~~must shall~~ be capable of demonstrating the required image quality. No intensifying screens ~~should shall~~ be used. ~~The film should~~ Radiographic films shall be processed in accordance with Guide E 999.

5.5 *Image Measurement Apparatus*—This apparatus is used to measure the size of the image of the focal spot. The apparatus shall be an optical comparator with built-in graticule with 0.1 mm divisions or 0.001 in. divisions and magnification of 5× to 10×.

6. Procedure

6.1 Set up the exposure arrangement as shown in Figs. 4-7. Position the X-ray tube directly over the center of the film. The film plane must be normal to the central ray of the X-ray beam. The X-ray focal spot should be 0.90 m (36 in.) [36 in.] from the film. Position the reference sample and apparatus used to locate the subject source (source stop) as close together as possible and directly over the center of the film. The plane of the source stop and reference sample must be parallel to the film and normal to the central ray of the X-ray beam. The source stop and reference sample should be 0.15 m (6 in.) [6 in.] from the film. The source stop should be connected to the radiographic exposure device by the shortest source guide tube practicable in order to minimize fogging of the film during source transit.

6.2 Place identification markers to be imaged on the film to identify, as a minimum, the identification (serial number) of the subject source, the size of the reference sample, the identification of the organization performing the determination, and the date

TABLE 1 Examples of Typical X-ray Generator Output Requirements for Related Iridium¹⁹² Source Activities

Subject Iridium ¹⁹² Source Radiation		Typical X-ray Generator Output Requirements		
Activity (Curie)	Output (R/h at 1 m)		Potential	Current
30	14.4		160 kV	5 mA
		or	200 kV	3 mA
100	48.0		160 kV	10 mA
		or	250 kV	4 mA
200	96.0		160 kV	20 mA
		or	250 kV	8 mA
		or	300 kV	6 mA

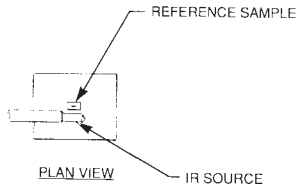
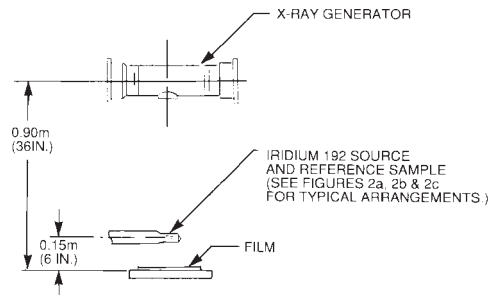

FIG. 4 Typical Exposure Arrangement

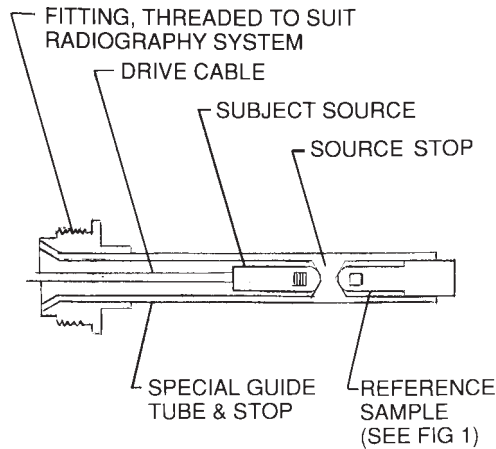

FIG. 5 Typical Arrangement Using a Specially Designed Guide Tube

of the determination. Care should be taken to ensure that the images of the subject source and reference sample will not be superimposed on the image of the identification markers.

6.3 *Exposure*—Select the X-ray tube potential (kV), X-ray tube current (mA) and exposure time such that the density in the image of the envelope surrounding the reference sample does not exceed 3.0 and that the density difference between the image of the reference sample and the image of the envelope surrounding the reference sample is at least 0.10.

NOTE 1—The actual parameters that will produce acceptable results may vary between X-ray units, and trial exposures may be necessary.

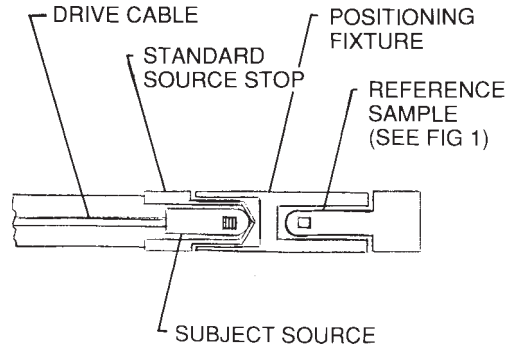

FIG. 6 Typical Arrangement Using a Standard Guide Tube and Special Positioning Fixture

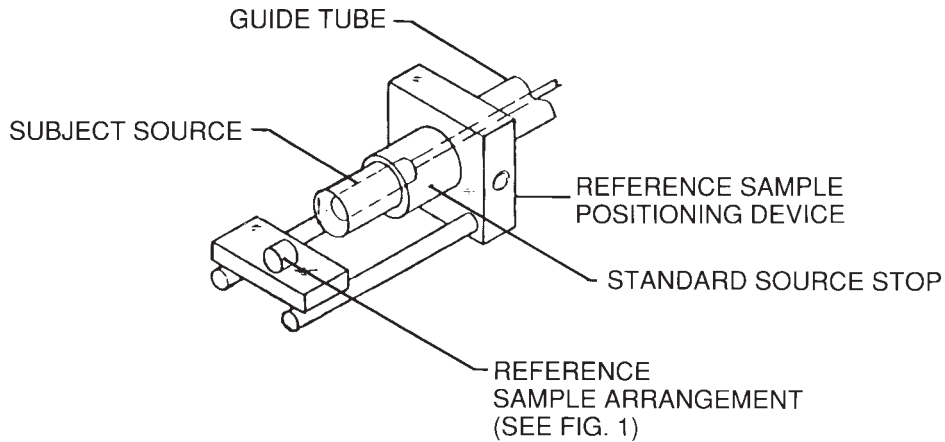

FIG. 7 Typical Arrangement Using Reference Sample Positioning Device

6.3.1 Energize the X-ray generator and, at the same time, manipulate the subject source into the exposure position in the source stop. It is important that this be performed as quickly as possible to minimize fogging of the film.

6.3.2 At the conclusion of the exposure time, deenergize the X-ray generator and, at the same time, return the subject source to the proper shielded storage position.

6.3.3 Process the film.

7. Measurement of Focal Dimensions

7.1 View the radiograph with sufficient light intensity for adequate viewing. Using an optical comparator with built-in graticule as described in 5.5, measure the linear dimensions of the image of the focal spot of the subject source and the reference sample. Take measurements from the perceptible edges of the image. When performing the physical measurements with the optical comparator, the actual measured values shall be to the nearest graduation on the graticule scale being used.

7.2 The focal size for a given technique is the maximum projected dimension of the source in the plane perpendicular to a line drawn from the source to the object being radiographed. Therefore, sufficient measurements of the image of the iridium must be made to determine the focal size of the source in any orientation. Sections 7.2.1-7.2.4 serve as examples.

7.2.1 *Uniform Right Circular Cylinder* (see Fig. 8)—Determine the focal size of a uniform right circular cylindrical source by measuring the diameter, d , the height, h , and the diagonal, m , as illustrated in Fig. 8 and computing the actual dimensions as described in 8.1.

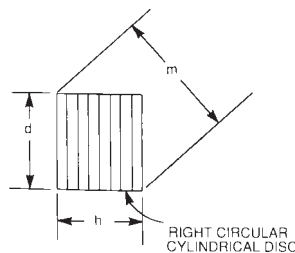

FIG. 8 Uniform Right Circular Cylinder

7.2.2 *Sphere* (see Fig. 9) —Determine the focal size of a spherical source by measuring the diameter, d , as illustrated in Fig. 9 and computing the actual dimension as described in 8.1.

7.2.3 *Nonuniform Stack of Right Circular Cylinders* (see Fig. 10)—Determine the focal size of a nonuniform stack of right circular cylindrical components of a source by measuring the intrinsic diameter, d , the height, h , and the effective maximum dimension, m , as illustrated in Fig. 10 and computing the actual dimensions as described in 8.1.

7.2.4 *Separated Stack of Right Circular Cylinders* (see Fig. 11)—Determine the focal size of a separated stack of right circular cylindrical components of a source by measuring the intrinsic diameter, d , the effective height, h , and the effective maximum dimension, m , as illustrated in Fig. 11 and computing the actual dimensions as described in 8.1.

8. Calculation and Evaluation

8.1 Measure the linear dimension of interest in the subject source image and measure the same linear dimension in the reference sample image (that is, the diameter of each). The actual dimension of the subject source is computed from the following:

$$a = bc/d$$

where:

a = actual dimension of the subject source,

b = actual dimension of the reference sample,

c = measured dimension of the subject source image, and

d = measured dimension of the reference sample image.

9. Report

9.1 A report of the focal size of an iridium-192 source should indicate the model number and serial number of the source, the name of the organization making the determination, the date the determination was made, a description of the shape of the source (or an appropriate sketch), and the calculated actual dimensions. The actual radiograph should accompany the report.

10. Keywords

10.1 cylinder(s); focal size; iridium 192; radiographic source; reference sample; sphere

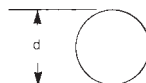

FIG. 9 Sphere

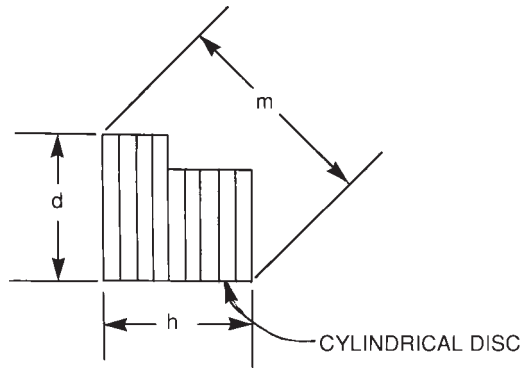

FIG. 10 Nonuniform Cylindrical Stack

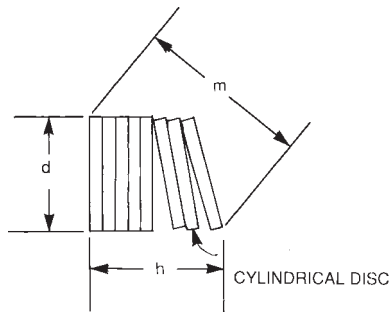

FIG. 11 Separated Cylindrical Stack

ASTM International takes no position respecting the validity of any patent rights asserted in connection with any item mentioned in this standard. Users of this standard are expressly advised that determination of the validity of any such patent rights, and the risk of infringement of such rights, are entirely their own responsibility.

This standard is subject to revision at any time by the responsible technical committee and must be reviewed every five years and if not revised, either reapproved or withdrawn. Your comments are invited either for revision of this standard or for additional standards and should be addressed to ASTM International Headquarters. Your comments will receive careful consideration at a meeting of the responsible technical committee, which you may attend. If you feel that your comments have not received a fair hearing you should make your views known to the ASTM Committee on Standards, at the address shown below.

This standard is copyrighted by ASTM International, 100 Barr Harbor Drive, PO Box C700, West Conshohocken, PA 19428-2959, United States. Individual reprints (single or multiple copies) of this standard may be obtained by contacting ASTM at the above address or at 610-832-9585 (phone), 610-832-9555 (fax), or service@astm.org (e-mail); or through the ASTM website (www.astm.org).