



Designation: E 1135 – 97

Standard Test Method for Comparing the Brightness of Fluorescent Penetrants¹

This standard is issued under the fixed designation E 1135; the number immediately following the designation indicates the year of original adoption or, in the case of revision, the year of last revision. A number in parentheses indicates the year of last reapproval. A superscript epsilon (ϵ) indicates an editorial change since the last revision or reapproval.

1. Scope

1.1 This test method describes the techniques for comparing the brightness of the penetrants used in the fluorescent dye penetrant process. This comparison is performed under controlled conditions which eliminate most of the variables present in actual penetrant examination. Thus, the brightness factor is isolated and is measured independently of the other factors which affect the performance of a penetrant system.

1.2 The brightness of a penetrant indication is dependent on the developer with which it is used. This test method however, measures the brightness of a penetrant on a convenient filter paper substrate which serves as a substitute for the developer.

1.3 The brightness measurement obtained is color-corrected to approximate the color response of the average human eye. Since most examination is done by human eyes, this number has more practical value than a measurement in units of energy emitted. Also, the comparisons are expressed as a percentage of some chosen standard penetrant because no absolute system of measurement exists at this time.

1.4 *This standard does not purport to address all of the safety concerns, if any, associated with its use. It is the responsibility of the user of this standard to establish appropriate safety and health practices and determine the applicability of regulatory limitations prior to use.*

2. Referenced Documents

2.1 ASTM Standards:

E 691 Practice for Conducting an Interlaboratory Study to Determine the Precision of a Test Method²

E 1316 Terminology for Nondestructive Examinations³

3. Terminology

3.1 Definitions:

3.1.1 Definitions of terms applicable to this test method may be found in Terminology E 1316.

4. Summary of Test Method

4.1 Simulated indications are prepared by impregnating filter paper with a specified quantity of the penetrant under test. The samples and similarly prepared standards are then measured in a fluorometer equipped to excite the penetrant with near ultraviolet (black) light and respond to color approximately as does the human eye under the conditions encountered during a normal examination. The fluorometer must be equipped with a special sample holder to accept the samples employed.

4.2 The sample preparation is not indicative of the total system performance but is convenient as a lot acceptance test. A known amount of penetrant is diluted with a specified amount of a volatile solvent, pieces of filter paper are soaked in the mixture, the paper is dried under specified conditions at room temperature, placed in the sample holder, and measured with the fluorometer.

5. Significance and Use

5.1 The penetrant is one of the major components of the fluorescent penetrant process, and very influential in the degree of performance attained by a given system or group of materials. The penetrant must enter the discontinuity, be removed from the part surface but not from the discontinuity, be brought out of the discontinuity by the developer, and finally viewed and detected by the inspector. If all processing parameters are optimized for the parts being tested and the test materials in use, the intrinsic brightness of the penetrant becomes the factor which governs the sensitivity of the system.

5.2 Because the eye responds logarithmically rather than linearly to changes of brightness, differences in brightness must be fairly large to be significant. Differences of 25 % are obvious, 12 % noticeable, and 6 % detectable by the eye. Experts may sometimes detect 3 % differences, but these are not usually significant to the average observer.

5.3 The significance of the results also depends on the deviation between readings on the same material sample. Different samples, even when prepared out of the same initial quantity of penetrant will not exactly reproduce readings. These differences occur because of paper differences and penetrant migration on the paper samples.

¹ This test method is under the jurisdiction of ASTM Committee E-7 on Nondestructive Testing and is the direct responsibility of Subcommittee E07.03 on Magnetic Particle and Penetrant Testing.

Current edition approved Feb. 10, 1997. Published April 1997. Originally published as E 1135 – 86. Last previous edition E 1135 – 86 (1992)¹.

² *Annual Book of ASTM Standards*, Vol 14.02.

³ *Annual Book of ASTM Standards*, Vol 03.03.

 **E 1135 – 97**

5.4 To determine the confidence limits for the test results, it is necessary to perform certain statistical calculations. The confidence limits are determined by the equation:

$$CL = \bar{X} \pm ts/\sqrt{n} \quad (1)$$

6.7 *Silica Gel*, for use as desiccant.

7. Sample Preparation

7.1 *Sample Preparation*—Normally a set of samples of a standard material must be prepared along with any test



FIG. 1 Turner Fluorometer, with Door Open Showing Sample Holder and Filters in Place

where:

CL = the limits within which we can be confident the value lies,

\bar{X} = the average of all readings,

t = “student’s t ” (values of which are given by statistical manuals),

n = the number of readings used,

s = the standard deviation determined by the equation:

$$S = \sqrt{\frac{\sum (X - \bar{X})^2}{n - 1}} \quad (2)$$

where:

X = the individual readings.

In this use, the 95 % confidence level (the value will lie within the limits 95 % of the time) is sufficient. At this level, t for 4 samples is 3.182.

5.4.1 If the confidence limits of two material samples overlap, the materials must be considered equal even though the measured average values are different.

6. Apparatus

6.1 *Filter Paper*, Whatman #4, a fast, open structured paper.

6.2 *Pipets*, 1-mL capacity.

6.3 *Volumetric Flasks*, with stopper, 25-mL.

6.4 *Paper Drying Holders*—“Crocodile” type battery clips 2 in. long with ½ in. opening have been found satisfactory. Set up holders to allow drying inside desiccator.

6.5 *Methylene Chloride or Acetone*, technical grade.

6.6 *Desiccator*, 250-mm diameter or larger.

samples.

7.1.1 Pipet 1.0 mL of chosen penetrant into a 25-mL stoppered volumetric flask.

7.1.2 Fill flask to line with methylene chloride, stopper and mix. (If penetrant is not soluble in methylene chloride, use acetone.)

7.1.3 Pour 10 to 20 mL of mixture into a 50-mL beaker.

7.1.4 Using forceps, dip 4 papers (cut to size for sample holder in use), one at a time, into beaker, withdraw by drawing across the lip of the beaker to remove excess liquid, and clip into paper drying holder. Holder shall cover as small an area of paper as possible.

7.1.5 Hang papers in a vertical position inside desiccator until dry. This will require approximately 5 min at room temperature.

8. Procedure for Turner Fluorometer^{4,5}

NOTE 1—All available apparatus may not be suitable for these applications.

8.1 *Sample Holder*, designed for the fluorometer in use.

8.1.1 The sample holder for the Turner Fluorometers (see Fig. 1) is detailed in Fig. 2. It is designed for use in the standard door from which the spring clip and the interior portion of the tube holder have been removed.

⁴ The sole source of supply for the Turner Fluorometer known to the committee at this time are Turner models 110, 111, 112 made by Sequoia-Turner of Mountain View, CA.

⁵ If you are aware of alternative suppliers, please provide this information to ASTM Headquarters. Your comments will receive careful consideration at a meeting of the responsible technical committee,¹ which you may attend.

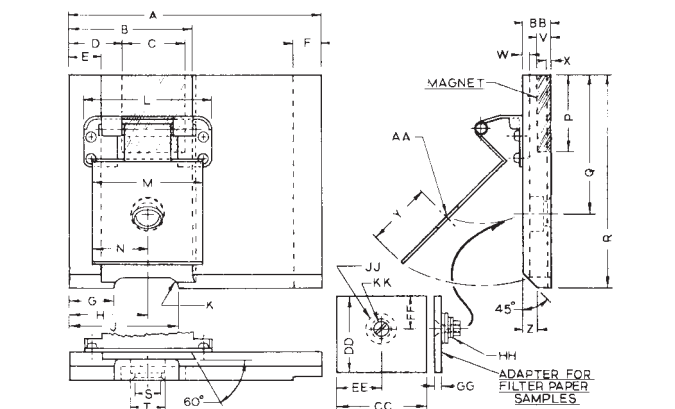

Dimensions

	in.	mm
A	4.5	114.3
B	2.186	55.52
C	1.125	28.575
D	0.875	22.225
E	0.563	14.30
F	0.50	12.70
G	0.813	20.65
H	1.375	34.925
J	1.938	49.225
K	0.188 radius (2)	4.775
L	2.25	57.15
M	2.00	50.80
N	1.00	25.40
P	1.375	34.925
Q	2.50	63.50
R	3.813	96.85
S	0.438 diameter drill thru	11.125
T	0.625 diameter counterbore 0.25 deep	15.875
V	0.25	6.35
W	0.125	3.175
X	0.063	1.60
Y	1.125	28.575
Z	0.25	6.35
AA	0.50 drill thru & chamfer	12.70
BB	0.50	12.70
CC	1.594	40.489
DD	1.375	34.925
EE	0.797	20.244
FF	0.625	15.875
GG	0.125	3.175
HH	(2) No. 6 flat washers	
JJ	(2) 3/16 in. (4.76 mm) flat washers	
KK	(1) No. 6 (0.138) flat head machine screw 1/2 in. (12.7 mm) long & hex nut	

FIG. 2 Sample Holder for the Turner Fluorometer

8.2 *Primary Light Filter*—The primary (light source) filter for the Turner fluorometers is a Corning-Kopp CS 7-37 2-in square^{5,6} glass filter.

8.3 *Secondary Light Filters*—The secondary (detector) filter system consists of a Corning-Kopp 3-77 and Kodak #2A, 86A and CC40Y.^{5,7} The Turner fluorometer requires 2 in. square filters.

8.4 *Neutral Density Intensity Reducing Filters*—An assortment of photographic type filters are required. These should be

the same size as the secondary filters (8.3) and the filters chosen for any measurement should be mounted with the secondary filters.

8.5 Place the primary filter in the right filter holder and the secondary filters in the left filter holder.

8.6 Insert neutral density filters in secondary filter position and set sensitivity control (under primary filter) to “1”.

8.7 Turn on instrument and allow 15 min warm up before use.

8.8 Place a prepared sample of the brightest material to be measured in the sample holder.

8.9 Place holder in instrument door, close door, and note reading. Open door and insert proper neutral density filters to bring reading on scale, preferably in the 70 to 90 scale division range.

8.10 Open door, remove sample holder, remove sample, and replace with an untreated filter paper.

8.11 Place sample holder in door, close door, and set reading to zero with “blank” control.

8.12 Remove blank paper and insert prepared samples for measurement. Alternate samples of unknown and standard material to minimize affect of any instrument drift which might occur.

9. Procedure for Coleman Fluorometer^{5,8}

9.1 *Sample Holder*—The sample holder for the Coleman Fluorometer (see Fig. 3) is detailed in Fig. 4. It is designed for



FIG. 3 Coleman Photofluorometer with Sample Holder

insertion into the sample port in the top of the instrument. Stops to control its rotation may be installed on the instrument case and the sample holder.

9.2 *Primary Light Filter*—The primary (light source) filter for the Coleman 12C is the Coleman B-1 or B-1-S filter.

⁶ The sole source of supply known to the committee at this time is Kopp Glass Inc., P.O. Box 8255, Pittsburgh, PA 15218.

⁷ The sole source of supply of the Kodak 2A, 86A, and CC40Y known to the committee at this time is Eastman Kodak, Inc., Rochester, NY 14650.

⁸ The sole source of supply of the Coleman Model 12C known to the committee at this time is Perkin Elmer of Norwalk, CT.

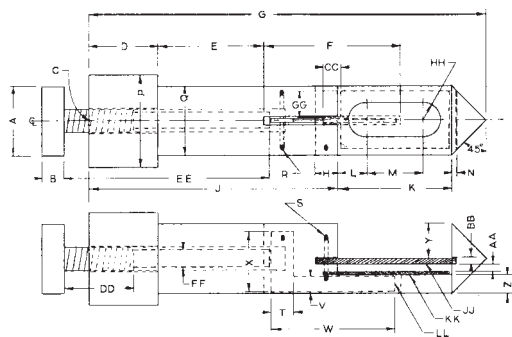

Dimensions

	in.	mm
A	0.75 diameter	19.05
B	0.25	6.35
C	#21 (.159 in.) diameter drill × 2.125 deep and 10–32 thread × 0.75 deep	4.039 53.975
D	0.75	19.05
E	1.125	28.58
F	0.125 Slot × 1.5 long	3.18 38.1
G	4.313	109.55
H	0.25	6.35
J	2.688	68.28
K	1.25	31.75
L	0.313	7.95
M	0.625	15.88
N	0.047	1.19
P	1.00 diameter	25.40
Q	0.75 diameter	19.05
R	Drive pin for Lifter Arm	
S	Drive pin for Face Plate	
T	0.25	6.35
V	0.344	8.74
W	1.344	34.14
X	0.656	16.66
Y	0.375	9.53
Z	0.190	4.826
AA	0.100	2.54
BB	0.063	1.60
CC	0.188	4.775
DD	10–32 thread × 0.75 long	19.05
EE	3.5	88.9
FF	0.125 diameter	3.175
GG	0.281	7.137
HH	0.186 radius (2)	4.72
JJ	Face Plate made of #16 gage (.0598 in.) sheet × .75 × 1.5	1.519 19.05 38.1
KK	Lifter Plate made of #22 gage (0.029 in.) sheet × 0.625 × 1.375	0.737 15.875 34.925
LL	Lifter Arm made of 0.063 plate	1.60

FIG. 4 Sample Holder for the Coleman 12C

9.3 *Secondary Light Filter*—The secondary (Detector) filter system consists of a Corning-Kopp 3-77 and Kodak #2A, 86A, and CC40Y. The filter size 1½ in. by 1½ in. These must be mounted in an empty filter frame to be inserted in the fluorometer.

9.4 *Neutral Density Intensity Reducing Filters*—An assortment of photographic type filters are required and should be mounted with the secondary filters.

9.5 Insert a Coleman B-1 or B-1-S filter (in Coleman filter frame) into primary filter position (horizontal position behind sensitivity control lever) and a package of filters consisting of a Corning CS 3-77, Kodak Wratten 2A, 86A and CC40Y, and

a 2.0 neutral density mounted in a Coleman filter frame, glass filter facing right, into the secondary filter position (vertical to left of the sample hole).

9.6 Turn on instrument and allow 15 to 30 min warm up.

9.7 Compare prepared papers under black light and choose one of the brightest group to set the instrument.

9.8 Place chosen prepared paper in sample holder, lock into place, and insert holder into sample port of fluorometer. Sample window should face away from operator at approximately a 45° angle to the left.

9.9 Set “Std” control and all blank controls in the middle of their adjustment ranges. (Do not force “Std” control or release notch stop under it since this will shut instrument off.)

9.10 Move sensitivity control full right, depress shutter button, and move sensitivity control gently left until meter reads near top of scale.

9.11 Remove sample holder, replace fluorescent paper with an untreated blank paper and reinsert in instrument.

9.12 Depress shutter button and rotate sample holder until highest reading is obtained. If reading goes off scale, move sensitivity control right until it is on scale.

9.13 With shutter button depressed, turn coarse blank control until meter reads approximately zero. Adjust to exactly zero with fine blank control.

9.14 Remove blank paper and insert brightest treated paper.

9.15 Depress shutter control and rotate sample until highest reading is obtained, then adjust “Std” control until meter reads approximately 90.

9.16 If desired adjustment cannot be attained, adjust sensitivity control, then repeat 9.11-9.15 until proper adjustment is obtained.

9.17 Measure papers, alternating standard and test samples to minimize the effect of instrument drift, should it occur.

10. Procedure For the Model S291^{5,9}

10.1 *Sample Holder*—The sample holder is pictured in Fig. 5. It is designed for insertion in the sample slot on the front of the photofluorometer. The sample holder comes with the instrument.

10.2 *Primary Light Filter*—The primary (Light source) filter for the S291 photofluorometer is an integrally filtered long-wave 4-W lamp.

10.3 *Secondary Light Filters*—The Model S291 photofluorometer uses a OGR^{5,10} green and OB14 blue^{5,9} glass filter that are preinstalled.

10.4 All filters are installed by the manufacturer and the instrument is ready for use.

10.5 Turn on the instrument and allow a 10 to 15 min warm up.

10.6 Compare the prepared papers under the black light and choose one of the brightest papers to set the instrument.

10.7 Place the chosen paper in the sample holder, and insert the holder into the sample port of the photofluorometer.

⁹ The sole source of supply of the Model S291 known to the committee at this time is NDT I Italiana SAS of Viale Monza, Italy.

¹⁰ The sole source of supply of the OGR green and OB14 blue glass filter known to the committee at this time is Chance Pilkington, London, Great Britain.

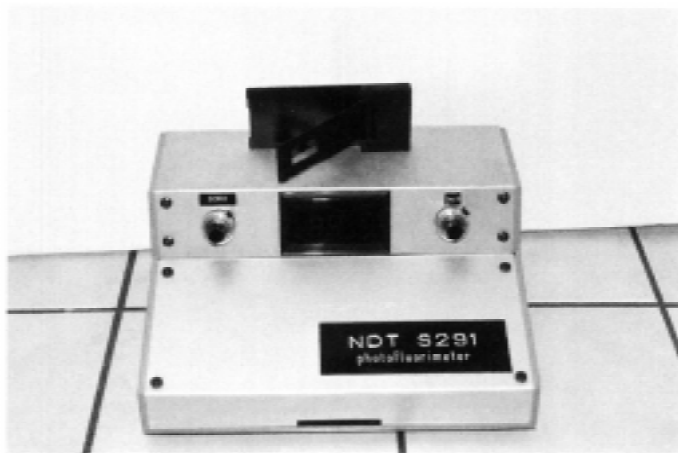

FIG. 5 Sample Holder

10.8 Adjust the meter response to 80 by turning the “CAL” adjustment knob.

10.9 Remove the sample holder, and replace the fluorescent paper with an untreated blank paper and re-insert into the instrument.

10.10 Adjust the meter response to 00 by turning the “Zero” adjustment knob.

10.11 Remove the blank paper and insert the prepared sample for measurement. Alternate samples of test and standard material to minimize effect of any instrument drift that might occur.

11. Calculation

11.1 Calculate the fluorescence of the test material as a percentage of that of the standard material by the formula

$$\bar{X}/\bar{S} \times 100 \quad (3)$$

where:

\bar{X} = the average of the test material reading, and

\bar{S} = the average of the standard material reading.

12. Precision and Bias

12.1 The results for the Turner Fluorimeters and the Coleman 12C small duplicate tests should not be considered suspect unless they differ by more than:

3.9 % repeatability (within the same laboratory)

14.0 % reproducibility (between different laboratories)

as determined according to Practice E 691.

12.2 No information can be presented on the bias of the procedure of Fluorescent Brightness Measurement using the Model S291 because there are not enough instruments in use to perform a study.

13. Keywords

13.1 brightness of dye penetrants; dye penetrants; fluorescent penetrants

ASTM International takes no position respecting the validity of any patent rights asserted in connection with any item mentioned in this standard. Users of this standard are expressly advised that determination of the validity of any such patent rights, and the risk of infringement of such rights, are entirely their own responsibility.

This standard is subject to revision at any time by the responsible technical committee and must be reviewed every five years and if not revised, either reapproved or withdrawn. Your comments are invited either for revision of this standard or for additional standards and should be addressed to ASTM International Headquarters. Your comments will receive careful consideration at a meeting of the responsible technical committee, which you may attend. If you feel that your comments have not received a fair hearing you should make your views known to the ASTM Committee on Standards, at the address shown below.

This standard is copyrighted by ASTM International, 100 Barr Harbor Drive, PO Box C700, West Conshohocken, PA 19428-2959, United States. Individual reprints (single or multiple copies) of this standard may be obtained by contacting ASTM at the above address or at 610-832-9585 (phone), 610-832-9555 (fax), or service@astm.org (e-mail); or through the ASTM website (www.astm.org).