



Standard Guide for Illuminators Used for Viewing Industrial Radiographs¹

This standard is issued under the fixed designation E 1390; the number immediately following the designation indicates the year of original adoption or, in the case of revision, the year of last revision. A number in parentheses indicates the year of last reapproval. A superscript epsilon (ϵ) indicates an editorial change since the last revision or reapproval.

1. Scope

1.1 This guide provides the recommended minimum requirements for illuminators used for viewing industrial film radiographs using transmitted light.

1.2 The illuminator has to ensure the same safety for personnel, or users of any electric apparatus, as specified by electrical standards applicable in the country in which the illuminator is used.

2. Referenced Documents

- 2.1 *ASTM Standards*:
E 1316 Terminology for Nondestructive Examinations²

3. Terminology

3.1 *Definitions*—For definitions of terms used in this guide, see Terminology E 1316.

4. Significance and Use

4.1 The function of the illuminator is to provide sufficient illumination and viewing capabilities to visually review industrial film radiographs by light transmitted through them for the purpose of identification and interpretation of the images.

4.2 This guide is to be used primarily for the manufacturer of illuminators and is not intended to be applicable to the users of illuminators. Requirements, if imposed on users, should be established by contractual agreement.

5. Design Characteristics

5.1 *General*—The illuminator shall consist of a housing with one or more of the sides containing a viewing screen illuminated from the inside of the housing. The viewing screen may also be the diffusing screen. There shall be thermal protection to prevent overheating, and subsequent damage to the radiographs placed on the viewing screen. The housing or system may or may not require ventilation. A rheostat or suitable electrical circuit shall be provided to vary the light intensity.

5.2 *Viewing Screen*—The viewing screen shall be easy to clean and made of material which is resistant to scratches. The

size of the screen shall allow the user to view the radiograph without excessive glare. If the illuminator is to be used for viewing radiographs of various sizes, masks of various sizes and configurations, for example, circular or rectangular, shall be provided. Alternately, an adjustable aperture may be used.

6. Illumination Requirements³

6.1 Luminance:

6.1.1 The luminance (or brightness) of the transmitted light through the radiograph shall not be less than 30 cd/m² for film densities equal or less than 2.5, and 10 cd/m² for film densities greater than 2.5.

NOTE 1—Where possible, approximately 100 cd/m² or higher luminance should be used.

6.1.2 To achieve the maximum luminance value, that is, 10 cd/m², given in 6.1.1, the illuminator brightness shall be at least 10⁵ cd/m². This should be determined with a suitably calibrated photometer or telephotometer placed at the center of the viewing surface. Follow manufacturer's instructions in using the photometer.

6.1.3 When servicing is required, it shall usually be sufficient to follow manufacturer's recommendations in, for example, replacing a bulb.

6.2 *Spectral Characteristics of Illuminator Light Source*—The color of the light used to illuminate the radiograph is normally "white." However, in the case of colored film bases, light with adapted colors may be used if they have been recommended by the film manufacturers.

6.3 *Diffusion of Light*—If the illuminator has a diffusing screen, the light shall be sufficiently divergent so that both eyes of the observer receive rays from all parts of the screen. The divergence factor shall exceed 0.7 (see 9.1.1).

6.4 *Uniformity of Illumination*—The screen shall be uniformly illuminated, the uniformity factor g being higher than 0.5 (see 9.1.2).

7. Anti-Glare Protection

7.1 The illuminator shall be fitted with an anti-glare switch or device that minimizes the probability of the operator being subjected to excessive glare when the radiograph is removed. This switch or device may be manual or automatic.

¹ This guide is under the jurisdiction of ASTM Committee E-7 on Nondestructive Testing and is the direct responsibility of Subcommittee E07.01 on Radiology (X and Gamma) Method.

Current edition approved Oct. 26, 1990. Published December 1990.

² *Annual Book of ASTM Standards*, Vol 03.03.

³ Luminance requirements are intended to be satisfied by the illuminator manufacturer.

8. Heating Protection

8.1 Appropriate precautions shall be taken to ensure that the temperature of the housing does not exceed 60°C (140°F) at the usual contact surface after one hour of operation at a 50 % duty cycle.

8.2 A radiograph having a density of 2.0 when placed on the illuminator viewing surface shall not warp or curl after 1 min of continuous viewing time and 1 h of operation of the illuminator at 50 % of duty cycle.

9. Photometric Measurements of Illuminator⁴

9.1 Photometric measurements of the illuminator shall be carried out in a darkened room. The photometer should be used in the middle part of its measuring scale. The illuminator shall not allow any direct light to escape when the viewing screen is completely masked.

9.1.1 *Divergence and Dispersion of Light (of Diffuser)*—The brightness shall be measured on a semi-circle, the center of which is center of the screen. The diameter of the circle is approximately the same as the maximum dimension of the screen (the diagonal). The radius of this semi-circle should be at least 25 cm (10 in.). The brightness is measured with the aid of an appropriate illumination photometer whose sensitive surface is tangent to the curve of the circle (see Fig. 1). These measurements shall be made at angles of 5° (L_5), 20° (L_{20}), and 45° (L_{45}) relative to the normal (L_0) to the diffusing screen. The divergence factor shall be calculated according to the following equation:

$$\text{Divergence Factor} = \frac{L_{45} + L_{20}}{2 L_5}$$

These measurements and calculations shall be made in both planes formed by the two diagonals and the corresponding semi-circle. For illuminators with variable intensity capability, they shall be made at three brightness levels (low, medium, high) along the diagonals of the rectangular screen or along two diameters at 90° angles to each other for a circular screen.

9.1.2 *Uniformity of Illumination on Screen*—If the screen is rectangular or circular, it shall be divided into squares measuring approximately 5.0 cm (2 in.) on a side. The brightness of each square shall be measured separately. In both cases, the network of the squares shall be arranged so that the middle square is centered in the middle of the screen. The average of the four highest and the average of the four lowest readings shall be determined. These averages will be designated L_{max} and L_{min} . The uniformity factor g shall be calculated according to the equation:

$$g = \frac{L_{min}}{L_{max}}$$

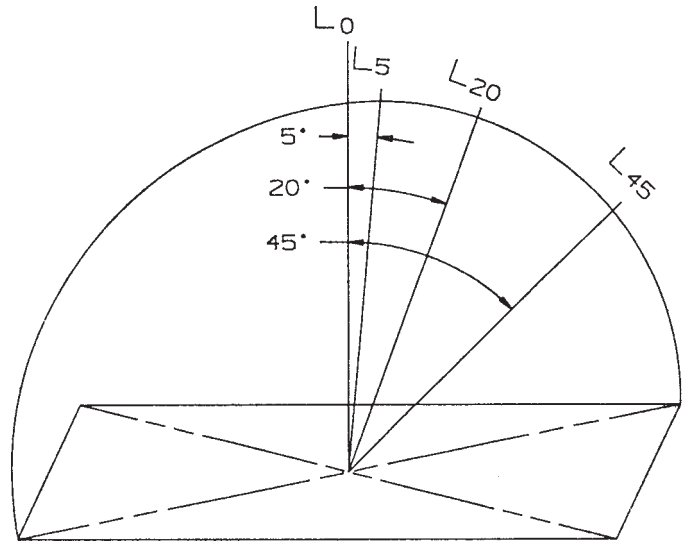

FIG. 1 Measurement Angles of Diversion and Dispersion of Light

These measurements and calculations for g shall be made at three brightness levels (low, medium, high).

10. Identification Marking

10.1 The following information shall be permanently affixed to the illuminator by the manufacturer:

- 10.1.1 Nominal operating voltage or permissible voltage range,
- 10.1.2 Nominal line frequency or permissible frequency range,
- 10.1.3 Whether direct, or alternating current, or both, may be used,
- 10.1.4 Nominal power consumption, and
- 10.1.5 Maximum brightness in cd/m^2 .

11. Operating Instructions

11.1 Operating instructions shall be provided with each illuminator, and include the following, as a minimum:

- 11.1.1 The operation of the illuminator,
- 11.1.2 Instructions for mounting and replacement of lamps and screens,
- 11.1.3 Care and maintenance procedures, and
- 11.1.4 Safety precautions.

12. Keywords

- 12.1 illumination; illuminator; radiographs; viewing

⁴ Photometric measurements are intended to be satisfied by the illuminator manufacturer.

ASTM International takes no position respecting the validity of any patent rights asserted in connection with any item mentioned in this standard. Users of this standard are expressly advised that determination of the validity of any such patent rights, and the risk of infringement of such rights, are entirely their own responsibility.

This standard is subject to revision at any time by the responsible technical committee and must be reviewed every five years and if not revised, either reapproved or withdrawn. Your comments are invited either for revision of this standard or for additional standards and should be addressed to ASTM International Headquarters. Your comments will receive careful consideration at a meeting of the responsible technical committee, which you may attend. If you feel that your comments have not received a fair hearing you should make your views known to the ASTM Committee on Standards, at the address shown below.

This standard is copyrighted by ASTM International, 100 Barr Harbor Drive, PO Box C700, West Conshohocken, PA 19428-2959, United States. Individual reprints (single or multiple copies) of this standard may be obtained by contacting ASTM at the above address or at 610-832-9585 (phone), 610-832-9555 (fax), or service@astm.org (e-mail); or through the ASTM website (www.astm.org).