



Designation: **A 341/A341M – 9500**

An American National Standard

## Standard Test Method for Direct Current Magnetic Properties of Materials Using D-C Permeameters and the Ballistic Test Methods<sup>1</sup>

This standard is issued under the fixed designation A 341/A341M; the number immediately following the designation indicates the year of original adoption or, in the case of revision, the year of last revision. A number in parentheses indicates the year of last reapproval. A superscript epsilon ( $\epsilon$ ) indicates an editorial change since the last revision or reapproval.

### 1. Scope

1.1 This test method provides dc permeameter tests for the basic magnetic properties of materials in the form of bars, rods, wire, or strip specimens which may be cut, machined, or ground from cast, compacted, sintered, forged, extruded, rolled, or other fabricated materials. It includes tests for determination of the normal induction under symmetrically cyclically magnetized (SCM) conditions and the hysteresis loop (B-H loop) taken under conditions of rapidly changing or steep wavefront reversals of the direct current magnetic field strength.

1.2 This test method shall be used in conjunction with Practice A 34/A 34M.

1.3 This test method covers a range of magnetic field strength in the specimen from about 0.05 Oe [4 A/m] up to above 5000 Oe [400 kA/M] through the use of several permeameters. The separate permeameters cover this test region in several overlapping ranges.

1.4 Normal induction and hysteresis properties may be determined over the flux density range from essentially zero to intrinsic saturation for most materials.

---

<sup>1</sup> This test method is under the jurisdiction of ASTM Committee A-6 A06 on Magnetic Properties and is the direct responsibility of Subcommittee A06.01 on Test Methods. Current edition approved Feb. 15, 1995; Oct. 10, 2000. Published April 1995; December 2000. Originally published as A 341 – 69. Last previous edition A 341 – 89 $\epsilon$  – 1 A 341/A 341M – 95.

1.5 Recommendations of the useful magnetic field strength range for each of the permeameters are shown in Table 1<sup>2</sup>. Also, see Sections 3 and 4 for general limitations relative to the use of permeameters.

1.6 The symbols and abbreviated definitions used in this test method appear with Fig. 1 and in appropriate sections of this document. For the official definitions, see Terminology A 340. Note that the term flux density used in this document is synonymous with the term magnetic induction.

1.7 The values and equations stated in ~~either customary (absolute (or practical) cgs-emu and inch-pound) units inch-pound~~ or SI units are to be regarded separately as standard. Within ~~this test method, the standard,~~ SI units are shown in brackets except for the sections concerning calculations where there are separate sections for the respective unit systems. The values stated in each system ~~are~~ may not be exact equivalents; therefore, each system shall be used independently of the other. Combining values from the two systems may result in nonconformance with ~~this specification standard.~~

1.8 *This standard does not purport to address all of the safety concerns, if any, associated with its use. It is the responsibility of the user of this standard to establish appropriate safety and health practices and determine the applicability of regulatory limitations prior to ~~use.~~<sup>2</sup> use.*

---

<sup>2</sup> The boldface numbers in parentheses refer to a list of references at the end of this standard.

**2. Referenced Documents**
**2.1 ASTM Standards:**

A 34/A 34M Practice for Procurement, Testing and Sampling and Procurement Testing of Magnetic Materials<sup>3</sup>

A 340 Terminology of Symbols and Definitions Relating to Magnetic Testing<sup>3</sup>

A 596/A 596M Test Method for Direct-Current Magnetic Properties of Materials Using the Ballistic Method and Ring Specimens<sup>3</sup>

A 773 Test Method for dc Magnetic Properties of Materials Using Ring and Permeameter Procedures with dc Electronic Hysteresigraphs- Specimens<sup>3</sup>

**2.2 IEC Standard:**

Publication 60404-4, Ed. 2.0 Magnetic Materials – Part 4: Methods of Measurement of the D-C D.C. Magnetic Properties of Solid Iron and Steel, IEC, 1982, 1995<sup>4</sup>

**2.3 Other Documents:-<sup>5</sup>**

NIST Circular No. 74, pg. 269:<sup>5</sup>

<sup>3</sup> Annual Book of ASTM Standards, Vol 03.04.

<sup>4</sup> Available from American National Standards Institute, 11 W. 42nd St., 13th Floor, New York, NY 10036.

<sup>5</sup> Available from National Institute of Standards and Technology, (NIST), Gaithersburg, MD 20899.

**TABLE 1 Permeameters**

Permeameter	Useful Magnetizing Field Strength Range <sup>A</sup>		H Measuring Device <sup>B</sup>	Reluctance Compensation	Magnetizing Coils Surrounds Specimen	References <sup>5,2</sup>
	Oersteds	kA/M				
Babbitt	40/1 000	3 200/80 000	I, HG	yes	yes	(1,2)
Babbitt	40/1000	3.2/80	I, HC	yes	yes	(1,2)
Burroughs	0.1/300	8/24 000	I	yes	yes	(1,3,4,5)
Burroughs	0.1/300	0.008/24	I	yes	yes	(1,3,4,5)
Fahy Simplex <sup>C</sup>	0.1/300	8/24 000	HG	no	no	(1,4,5,6,7)
Fahy Simplex <sup>C</sup>	0.1/300	0.008/24	HC	no	no	(1,4,5,6,7)
Fahy Simplex-Super H Adapter <sup>C</sup>	100/2 500	8 000/200 000	HG	no	no	(1,3)
Fahy Simplex-Super H adapter <sup>C</sup>	100/2500	8/200	HC	no	no	(1,3)
Full Range	0.05/1 400	4/1 400	HG	yes	yes	(1,8)
Full range	0.05/1400	0.004/112	HC	yes	yes	(1,8)
High H <sup>D</sup>	100/5 000	8 000/400 000	FG	yes	no	(1,5,7,9)
High H	100/5000	8/400	FC	yes	no	(1,5,7,9)
Iliovici <sup>D</sup>	0.5/500	40/400 000	I, HG	yes	yes	(4,10,11)
Iliovici	0.5/500	0.04/400	I, HC	yes	yes	(4,10,11)
Isthmus	100/20 000 +	8 000/1 600 000 +	HC, HP	no	yes	IEC 60404-4
IEC Type A	0.1/2500	0.008/200	HC, HP	no	yes	IEC 60404-4
IEC Type B	0.1/630	0.008/50	RCC	no	no	IEC 60404-4
Isthmus	100/20 000+	8/1600+	HC, HP	no	no	(1,4,12,13)
MH <sup>D</sup>	0.1/300	8/2 400	FG	yes	yes	(1,6,14)
MH	0.1/300	0.008/24	FC	yes	yes	(1,6,14)
NPL <sup>D</sup>	0.5/2 500	40/200 000	I, HG	yes	yes	(15)
NPL	0.5/2500	0.04/200	I, HC	yes	yes	(15)
Saturation	100/4 000	8 000/400 000	HG	no	yes	(5,16,17)
Saturation	100/4000	8/320	HC	no	yes	(5,16,17)

<sup>A</sup> Although the permeameters are capable of being used at the lower end of the measurement range, the measurement accuracy is reduced. Best overall accuracy is obtained for a combination of high flux density and high magnetic field strength such as is encountered in the testing of permanent magnet materials.

<sup>B</sup> I—magnetizing current; HC—fixed H coil; FC—flip coil; HP—Hall Probe. RCC—Rogowski-Chattock coil.

<sup>C</sup> Fahy permeameters require a standard of known magnetic properties for calibration of the H coil.

<sup>D</sup> These permeameters are recommended by the International Electrotechnical Commission.

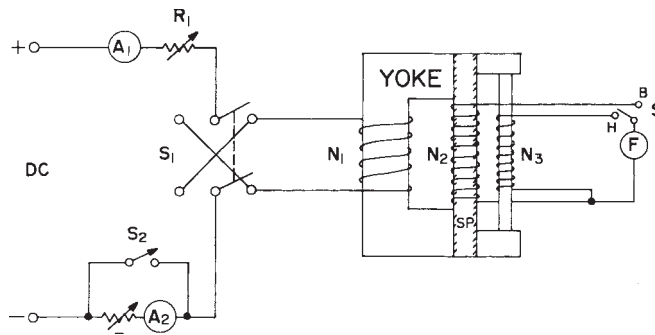

NOTE 1—

- $A_1$ —Multirange ammeter (main current)
- $A_2$ —Multirange ammeter (hysteresis current)
- $B$ —Flux density test position for switch  $S_3$
- $F$ —Electronic Integrator
- $H$ —Magnetic field strength test position for switch  $S_3$
- $N_1$ —Magnetizing coil
- $N_2$ —Flux sensing ( $B$ ) coil
- $N_3$ —Magnetic field strength sensing coil
- $R_1$ —Main current control rheostat
- $R_2$ —Hysteresis current control rheostat
- $S_1$ —Reversing switch for magnetizing current
- $S_2$ —Shunting switch for hysteresis current control rheostat
- $S_3$ —Integrator selector switch
- $SP$ —Specimen

FIG. 1 Basic Circuit Using Permeameter

NIST Scientific Paper 117, SPBTA<sup>5</sup>

### 3. Significance and Use

3.1 Permeameters require the use of yokes to complete the magnetic circuit and are therefore inherently less accurate than ring test methods. Refer to Test Method A 596/A 596M for further details on ring test methods. However, when testing certain shapes as bars or when magnetic field strength in excess of 200 Oe [15.9 or more kA/m] are required, permeameters are the only practical means of measuring magnetic properties.

3.2 This test method is suitable for specification acceptance, service evaluation, research and development and design.

3.3 When the test specimen is fabricated from a larger sample and is in the same condition as the larger sample, it may not exhibit magnetic properties representative of the original sample. In such instances the test results, when viewed in context of past performance history, will be useful for judging the suitability of the material for the intended application.

### 4. Interferences

4.1 In general, permeameters do not maintain a uniform magnetic field in either the axial or radial directions around the test specimen. The field gradients in both of these directions will differ in the various permeameters. Also the  $H$ -sensing and  $B$ -sensing coils of the different permeameters are not identical in area, in turns, or in length or identically located. Although test specimens are prepared to have uniform physical cross section, they may have undetected nonuniform magnetic properties radially or axially along the specimen length adjacent to the  $H$ - or  $B$ -coils. Some permeameters may also introduce clamping strains into the test specimen. For the above reasons test results obtained on a test specimen with one type permeameter may not agree closely with those obtained on the same test specimen using another type of permeameter.

### 5. Apparatus

5.1 Because of the differences in physical construction of the various permeameters listed in Table 1, no standard list of components is given. When used with a particular type of permeameter, the components should conform to the general requirements listed below. A basic schematic of a permeameter is shown in Fig. 1.

5.2 *Permeameter*—The particular permeameter used shall be of high quality construction. The yokes should be made of high permeability alloy such as oriented or nonoriented silicon iron or nickel-iron alloy, although low carbon steel or iron is acceptable in certain instances. The preferred yoke dimensions are listed in the appended references (see Table 1). Deviations from these dimensions should be such that the yoke is operating at or below the point of maximum permeability for the highest test flux densities encountered. Yoke construction may consist of either stacked laminations or stripwound C-cores suitably bolted or adhesive bonded together.

5.3 *Power Supply*—The magnetizing current shall be supplied by either storage batteries or dc power supplies. Bipolar programmable linear power supplies have been found to be well suited for this use. The source of dc current must be stable, have

negligible ripple and be capable of quickly returning to the stable state after switching. When programmable power supplies are used, either digital or analog programming signals are permissible provided that equal but opposite polarity current cycling is possible.

5.4 *Main-Current-Control Rheostats, R<sub>1</sub>*—When used, these rheostats must have sufficient power rating and heat-dissipating capacity to handle the voltage and largest test current and must contain sufficient resistance to limit the test currents to those required for the lowest magnetic field strength to be used.

5.5 *Hysteresis-Current-Control Rheostats, R<sub>2</sub>*—When used, these rheostats must have the same characteristics as the main-current control rheostats.

5.6 *Main-Current Ammeter, A<sub>1</sub>*—Magnetizing current measurement shall be conducted using a digital ammeter or combination of a digital voltmeter and precision shunt resistor with an overall accuracy of better than 0.25 % when the magnetic field strength will be determined from the current. In those permeameters where the magnetic field strength is determined by other means, such as Hall probes or *H*- coils, lower accuracy analog instruments can be used. In such permeameters, the ammeter is used to prevent excessive currents from being applied and, based on past experience, to roughly establish the required magnetic field strength.

5.7 *Hysteresis-Current- Ammeter, A<sub>2</sub>*—The requirements of 5.6 shall apply. In general, a separate ammeter is not required.

5.8 *Reversing Switch, S<sub>1</sub>*—When nonprogrammable dc current sources such as storage batteries are used, a current reversing switch is required. The reversing switch should be either a high quality knife switch, mechanical or electrical solenoid-operated contractors or mercury switches having high current rating and the ability to maintain uniform contact resistance of equal magnitude in both current directions. Switches with contact bounce or other multiple contacting behavior on make or break must be avoided. ~~Due to~~ Because of the presence of leakage currents in the open condition, solid state relays are not permitted.

5.9 *Hysteresis Switch, S<sub>2</sub>*—This single pole switch must conform to the same requirements as the reversing ~~s~~ Switch, S<sub>1</sub>.

5.10 *Integrator, F*—~~Due to~~ Because of their superior accuracy, stability, and ease of operation, electronic charge integrators are the preferred means of measuring magnetic flux. Integrators using either operational amplifier and capacitor feedback (analog integrator) or pulse counting are permitted. The accuracy of the integrator must be better than 1 % full scale. If analog display meters are used to read the value of flux, the measurement should be made on the upper two-thirds of the scale. Analog integrators must have drift adjust circuitry and the drift should not exceed 100 Maxwell-turns [ $10^{-6}$  Wb-turns] per minute on the most sensitive range. It is also desirable that the integrator have appropriate scaling circuitry to permit direct reading of either flux ( $\Phi$ ) or flux density (*B*). Ballistic galvanometers or moving coil fluxmeters are permitted provided the 1 % full-scale accuracy requirement is met. Such devices require additional circuitry not shown in Fig. 1. Details may be found in the appropriate references appended to this test method.

5.11 *B- Coils*—Prewound fixed flux sensing coils are often used. When used, the cross-sectional area enclosed by the secondary winding and number of turns must be known to be better than 0.5 %.

5.12 *Magnetic Field Strength Measuring Devices*—Certain permeameters do not or cannot use the magnetizing current to accurately determine the magnetic field strength accurately. Such permeameters instead use stationary *H*- coils, flip- coils, or Hall probes. When such devices are used, they shall be capable of determining the apparent magnetic field strength to accuracy of 1.0 % or better.

## 6. Test Specimens

6.1 Test specimen area shall normally be determined from mass, length, and density as indicated in 9.1 and 10.1. When the test specimen is machined or ground to have a very smooth surface, the physical dimensions obtained from micrometer measurements may be used to calculate the cross-sectional area.

6.2 Test specimens in bar form may be of round, square, or rectangular cross-sectional shape. In some permeameters the bar specimen may be a half round or any shape having a uniform cross-sectional area. Certain permeameters must have a good magnetic joint between the ends of the test specimen and the permeameter yoke or pole faces. Pole shoes may be necessary to create this joint. Generally, to achieve a good magnetic joint, the test specimen must be of square or rectangular cross section and must be machined or ground to have straight and parallel surfaces. For permeameters using specimens butted to pole pieces, the specimen ends must be smooth and parallel.

6.3 When the material is in flat-rolled form and is to be evaluated as half transverse-half longitudinal, the specimen shall be sheared to have strips in multiples of four in accordance with Table 2. When material is to be evaluated in one direction, it shall conform to this table or to the requirements for best test quality in a particular permeameter. For gages No. 33 and thinner, the cross-sectional area shall be not less than 0.31 in.<sup>2</sup> [200 mm<sup>2</sup>] and not more than 0.62 in.<sup>2</sup> [400 mm<sup>2</sup>].

6.4 When the test specimen for strip materials is to be half transverse and half longitudinal, the strips shall be positioned to be

**TABLE 2 Number of Test Strips**

Nominal Thickness		Gage Number	Number of Strips
in.	mm		
0.0100 to 0.0250	0.254 to 0.635	32 to 24, incl	12
0.0280 to 0.0435	0.711 to 1.105	23 to 19, incl	8
0.0500 and over	1.27 and over	18 and thicker	4

composed of alternately transverse and longitudinal throughout the specimen and a transverse strip shall be placed adjacent to the permeameter's yoke or pole face.

6.5 For full testing accuracy, the length and size of the test specimen must meet the requirements of the permeameter being used. Generally, for most permeameters, a test specimen length of 10 in. [0.254 m] or more is required. Shorter specimens with some permeameters will require the use of pole-piece extensions, and may cause a reduction in testing accuracy. Other permeameters are designed for short specimens without loss of testing accuracy.

6.6 All test specimen forms shall be cut, machined, or ground to have a uniform cross-sectional area along the active length of the test specimen. The cross-sectional area shall be sufficiently uniform so that its nonuniformity will not materially affect the accuracy of establishing and measuring flux density in the test sample.

6.7 When required for development of material properties the test specimen shall have received a stress relief or other heat treatment after preparation. This anneal is subject to agreement between manufacturer and purchaser; manufacturer's recommendation; or the recommended heat treatment provided by the appropriate ASTM standard for the material. The heat treatment used shall be reported with the magnitude test results.

6.8 Specimens of permanent-magnetic materials shall be processed ~~prior to~~ before testing in accordance with a procedure acceptable to both manufacturer and purchaser. The processing used shall be reported with the test results.

## 7. Calibration

7.1 *Integrator*—Practical operating experience has shown that provided a proper warmup period is allowed, electronic integrators require infrequent calibration and unlike ballistic galvanometers, calibration is not an integral part of this test method. When calibration is required, it can be accomplished with either a mutual inductor or a volt-second source. ~~Due to~~ Because of their traceability to the fundamental units of voltage and time, volt-second sources are the preferred means of calibration. The accuracy of either the mutual inductor or volt-second source must be better than the rated full scale accuracy of the integrator.

7.2 *Fixed-B-B and H- Coils*—The effective area turns of such search coils can be determined by comparison with a coil of known area- turns or by individual calibration in a series of known magnetizing fields. Such fields can be obtained using either long solenoid electromagnetics or large Helmholtz coil systems.

7.3 *Comparison Permeameters*—Certain types of permeameters such as the Fahy permeameter require a standard specimen of known magnetic properties ~~in order~~ to derive the relationship between field sensor output and true magnetic field strength. Instead of nationally recognized standard specimens, a standard may be developed by mutual agreement between manufacturer and purchaser, and if possible, a referee laboratory.

## 8. Procedure

8.1 Most permeameters ~~utilize~~ use a compensating system of magnetizing coils to provide extra magnetomotive force to overcome the reluctance of the yokes and joints in the magnetic circuit. Hence, the detailed operation procedure will vary somewhat with the type of permeameter used. Detailed operating procedures can be found in the references appended to this test method. The procedure listed below is common to all types of permeameters.

8.2 In Fig. 1, the dc power source supplies testing current measured by ammeter  $A_1$ . Rheostats  $R_1$  and  $R_2$  and ~~s~~ Switches  $S_1$  and  $S_2$  determine the magnitude and direction of the current as required by various operations. In general, three kinds of switching operations are required in ballistic testing. One is reversal of magnetizing current direction without change of magnitude as required for establishing a cyclic condition and in normal magnetic tests. This is done by throwing ~~s~~ Switch  $S_1$  from one side to another. A second is reduction of magnitude of magnetizing current without change of direction. This is done by opening ~~s~~ Switch  $S_2$ . The third operation combines reversal of direction of magnetizing current with reduction in magnitude. This is done by simultaneously throwing ~~s~~ Switch  $S_1$  from one side to the other and opening ~~s~~ Switch  $S_2$ . Use care to be sure  $S_2$  is opened before  $S_1$  is closed for reversal. When determining the hysteresis loop, ~~s~~ Switches  $S_1$  and  $S_2$  must be operated to traverse the loop in the same direction between successive measurements so as to preserve the cyclically magnetized state of the test specimen.

8.3 Before testing, demagnetize the specimen in the permeameter or by some other acceptable means. Demagnetize by first establishing a magnetic field strength sufficiently large to cause the flux density in the test specimen to reach a point well above the knee of the magnetization curve. Then while continuously operating the reversing switch at half-second or longer intervals, slowly reduce the magnetizing current to zero in small increments. An auxiliary demagnetizing circuit using a time delay relay will make this operation more reproducible and less tedious.

8.4 To obtain the flux density ( $B$ ) corresponding to a specific magnetic field strength ( $H$ ), establish the proper magnetic field strength, cycle the reversing switch several times to establish the symmetrically cyclically magnetized (SCM) condition, zero the integrator and execute the proper switching procedure detailed in 8.2. The value of the flux or flux density can then be computed from the integrator reading. Additional test points on the magnetization curve can be obtained without demagnetization if they are obtained in ascending order of  $B$  or  $H$ . Otherwise, it is necessary to demagnetize ~~prior to~~ before additional testing.

8.5 To obtain the magnetic field strength corresponding to a specific flux density, a procedure similar to 8.4 is used with the exception that the magnetic field strength must be found by trial and error. If the specified flux density is exceeded, demagnetization is usually required before proceeding further unless operating at very low flux densities.

8.6 Electronic integrators do not determine flux densities directly, rather the change in flux linkages ( $N_2\Delta\phi$ ) is measured. This result is converted to changes in flux density by division by the specimen cross-sectional area  $A$  and number of secondary turns

$N_2$ . To determine the actual value of flux density, the starting or reference points must be known. In the case of magnetization curve measurements, it is customary to zero the integrator and measure the change in flux density for a fully reversed change in magnetic field strength. In this instance, the true value of flux density is one half of the total change in flux density. For hysteresis loop determination, the integrator is zeroed at the point of maximum magnetic field strength. The resulting change in flux density is equal to the difference in flux density between the point of maximum magnetization force and the point corresponding to the hysteresis loop measurement magnetic field strength.

## 9. Calculation (Modified cgs Units)

9.1 The sample cross-sectional area shall normally be determined from test specimen mass, length, and density using the equation:

$$A = m/\delta l \quad (1)$$

where:

- $A$  = cross-sectional area,  $\text{cm}^2$ ;
- $m$  = mass of specimen,  $\text{g}$ ;
- $\delta$  = density of material,  $\text{g}/\text{cm}^3$ ; and
- $l$  = specimen length,  $\text{cm}$ .

9.2 In permeameters using a fixed  $B$ - coil, the  $B$ - coil cross-sectional area is often much larger than the test specimen cross-sectional area; when this occurs, a correction for air flux in the  $B$ - coil is required. This correction shall be made as shown in 9.2.1 through 9.2.3.

9.2.1 The geometric correction factor is given by:

$$K = (a - A)/A \quad (2)$$

where:

- $a$  = cross-sectional area of test ( $B$ ), coil,  $\text{cm}^2$ , and
- $A$  = cross-sectional area of test specimen,  $\text{cm}^2$ .

9.2.2 The corrected flux density is given by:

$$B = B_{\text{obs}} - K\Gamma_m H \quad (3)$$

where:

- $B$  = actual flux density,  $\text{G}$ , in test specimen;
- $B_{\text{obs}}$  = measured flux density,  $\text{G}$ ;
- $H$  = magnetic field strength,  $\text{Oe}$ ; and
- $\Gamma_m$  = magnetic constant of free space = 1.

9.2.3 For determining the value of flux density at a point on a hysteresis loop, the corrected flux density is given by:

$$B = B_m - (\Delta B_{\text{obs}} - K\Gamma_m \Delta H) \quad (4)$$

$$B = B_m - (\Delta B_{\text{obs}} - K\Gamma_m \Delta H) \quad (4)$$

where:

- $B$  = flux density,  $\text{G}$ , at the test point on hysteresis loop;
- $B_m$  = maximum value of SCM flux density,  $\text{G}$ , developed at magnetic field strength,  $H_m$ ;
- $\Delta B_{\text{obs}}$  = change in flux density from  $B_m$  to  $B$  at the test point;
- $\Delta H$  = change in magnetic field strength,  $\text{Oe}$ , required to reduce the flux density from  $B_m$  to  $B$  at the test point; and
- $\Gamma_m$  = magnetic constant of free space (in the cgs system  $\Gamma_m = 1$ ).

## 10. Calculation (SI Units)

10.1 The sample cross-sectional area shall normally be determined from test specimen mass, length, and density using the equation:

$$A = m/\delta l \quad (5)$$

where:

- $A$  = cross-sectional area,  $\text{m}^2$ ;
- $m$  = mass of specimen,  $\text{kg}$ ;
- $\delta$  = density of material,  $\text{kg}/\text{m}^3$ ; and

$l$  = specimen length, m.

10.2 In permeameters using a fixed  $B$ -coil, the  $B$ -coil cross-sectional area is often much larger than the test specimen cross-sectional area; when this occurs a correction for air flux in the  $B$ -coil is required. This correction shall be made as shown in 10.2.1 through 10.2.3.

10.2.1 The geometric correction factor is given by:

$$K = (a - A)/A \quad (6)$$

where:

$a$  = cross-sectional area of test ( $B$ ) coil,  $m^2$ , and

$A$  = cross-sectional area of test specimen,  $m^2$ .

10.2.2 The corrected flux density is given by:

$$B = B_{\text{obs}} - K\Gamma_m H \quad (7)$$

where:

$B$  = actual flux density, Teslas, in test specimen;

$B_{\text{obs}}$  = measured flux density, Teslas;

$H$  = magnetic field strength, A/m; and

$\Gamma_m$  = magnetic constant of free space =  $4\pi \times 10^{-7}$  H/m.

10.2.3 For determining the value of flux density at a point on a hysteresis loop, the corrected flux density is given by:

~~$$B = B_m - (\Delta B_{\text{obs}} - K\Gamma_m \Delta H) \quad (8)$$~~

$$B = B_m - (\Delta B_{\text{obs}} - K\Gamma_m \Delta H) \quad (8)$$

where:

$B$  = flux density, Teslas, at the test point on hysteresis loop;

$B_m$  = maximum value of SCM flux density, Teslas, developed at magnetic field strength,  $H_m$ ;

$\Delta B_{\text{obs}}$  = change in flux density from  $B_m$  to  $B$  at the test point;

$\Delta H$  = change in magnetic field strength, A/m, required to reduce the flux density from  $B_m$  to  $B$  at the test point; and

$\Gamma_m$  = magnetic constant of free space =  $4\pi \times 10^{-7}$  H/m.

## 11. Report

11.1 When normal induction or hysteresis tests are made in a permeameter, the following shall be reported along with the test data:

11.1.1 Name or type of permeameter used.

11.1.2 Size and shape of the test specimen.

11.1.3 Heat treatment or other processing applied to the test specimen ~~prior to~~ before testing.

11.1.4 When permeability is reported, the corresponding value of either  $B$  or  $H$  must be reported.

11.1.5 With hysteresis data, when coercive force, residual flux density, or other specific hysteresis test points are reported, the value of cyclically symmetrical peak magnetizing force or flux density must be reported.

11.1.6 When flux density values are reported, as those for saturation flux density, the corresponding value of magnetizing force must be reported.

## 12. Precision and Bias

12.1 The reliability of the results of magnetic tests in permeameters depends not only upon the method or apparatus used, but also upon the nature of the specimen. The most common sources of variations in magnetic properties due to the test specimen are:

(1) lack of uniformity in permeability along the length of the specimen, (2) mechanical strain, and (3) temperature variations. Variations due to as a result of these causes are difficult to measure and may be large.

12.2 In comparing the results of direct-current magnetic tests, it should be recognized that flux-density,  $B$ , and magnetic field strength,  $H$ , are independently determined quantities, each of which is separately subject to experimental error. The flux density errors include those caused by nonuniform flux density and nonuniform properties along the specimen length and, when fixed  $B$ -coils are used, errors due to imprecise air flux correction. Field distortion in permeameters can be severe around the test specimens and  $H$ -coils. For this reason the determination of magnetic field strength in the test specimen is inherently less accurate than the determination of flux density. With some permeameters the use of flip  $H$ -coils or multiple  $H$ -coils with extrapolation to the specimen surface or Hall effect devices may improve the accuracy of  $H$ -determination. However, the field around these devices and the test specimen can be distorted in both the axial and radial directions. To be effective they must be used in such a manner as to integrate the field around the test specimen and over the same length as that covered by the  $B$ -coil. The magnitudes of the various errors are peculiar to the test permeameter and the characteristics of the material under test. For a given set of

corresponding measured values of  $B$  coils are used, errors caused by imprecise air flux correction. Field distortion in permeameters can be severe around the test specimens and  $H$  coils. For this reason, the determination of magnetic field strength in the test specimen is inherently less accurate than the determination of flux density. With some permeameters the use of flip  $H$  coils or multiple  $H$  coils with extrapolation to the specimen surface or Hall effect devices may improve the accuracy of  $H$  determination. However, the field around these devices and the test specimen can be distorted in both the axial and radial directions. To be effective, they must be used in such a manner as to integrate the field around the test specimen and over the same length as that covered by the  $B$  coil. The magnitudes of the various errors are peculiar to the test permeameter and the characteristics of the material under test. For a given set of corresponding measured values of  $B$  and  $H$  wherein the errors are  $\pm\delta B$  and  $\pm\delta H$  in  $B$  and  $H$ , respectively, the true characteristic curve of the test specimen may lie anywhere within the boundaries of the region defined by the two curves  $(B + \delta B)$  versus  $(H - \delta H)$  and  $(B - \delta B)$  versus  $(H + \delta H)$ .

12.3 For specimens having a satisfactory degree of uniformity, clamped or mounted so as to be free from mechanical strain, and kept at a constant temperature within 5°C, for  $H$  greater than 1.0 Oe [79.6 A/m], the methods may be expected to determine average induction,  $B$ , to a precise of  $\pm 1\%$  and to determine average magnetic field strength,  $H$ , to the precisions indicated in Table 3. When these values are combined to calculate permeability,  $\mu$ , its precision may be expected to fall within the limits imposed by the sum of the precisions of measurement for the corresponding  $B$  and  $H$  values.

### 13. Keywords

13.1 coercive force; induction; magnetic field strength; magnetic test; permeability; permeameter; residual induction

## ANNEXES

### (Mandatory Information)

#### A1. SPECIAL TEST REQUIREMENTS FOR EVALUATION OF MATERIALS IN GENERATOR ROTOR FORGINGS (CUSTOMARY UNITS)

##### A1.1 Scope

A1.1.1 This annex covers the specific sampling and testing procedures required to evaluate the basic magnetic properties of materials used in generator-rotor forgings.

A1.1.2 Unless otherwise specified, the apparatus and procedures of this test method or other designations covering later improved test methods shall apply when testing for the magnetic properties related to normal induction and hysteresis.

**TABLE 3 Estimated Permeameter Precision of Measurement in Percent**

Test Permeameter	Test Specimen Operating Permeability; ( $B/H$ ) at the Test Induction	Precision of Measurement When Compared to Other Permeameters of the Same Type; ( $\pm$ )		Estimated Errors When Compared to Measurements Using Standard Ring Specimens ( <b>18</b> ); ( $\pm$ )	
		$B$	$H$	$B$	$H$
Fahy	1 to 100	1	2	2	4
	100 to 1 000	4	4	2	8
	100 to 1000	1	4	2	8
	1 000 to 5 000	4	8	2	16
	1000 to 5000	1	8	2	16
	5 000 and above 5000 and above	not recommended not recommended			
MH	1 to 100	1	1	1	2
	100 to 1 000	4	2	4	3
	100 to 1000	1	2	1	3
	1 000 to 5 000	4	4	4	5
	1000 to 5000	1	4	1	5
	5 000 to 10 000 5000 to 10 000	4	8	4	10
High $H$ Saturation	1 to 100	4	4	4	2
	1 to 100	4	4	4	3
High $H$ saturation	1 to 100	1	1	1	2
	1 to 100	1	1	1	3
Full range	1 to 100	4	4	4	3
	1 to 100	1	1	1	3
Full range	100 to 1 000	4	2	4	4
	100 to 1000	1	2	1	4
	1 000 to 5 000	4	4	4	5
	1000 to 5000	1	4	1	5
	5 000 to 10 000	4	8	4	10
	5000 to 10 000	1	8	1	10

A1.1.3 Materials covered in the requirements of this appendix include heat-treated carbon and alloy steels when used for generator-rotor forgings.

A1.1.4 Terminology A 340 shall apply to this annex.

### A1.2 Test Specimens (Customary Units)

A1.2.1 Test specimens shall consist of bars ground smooth to 100  $\mu\text{in.}$  (rms) maximum not less than 5 in. long by  $0.500 \pm 0.010$  in. square or cylindrical and shall have square ends. The diameter or thickness of individual specimens shall be uniform within  $\pm 0.0010$  in. The sides of square bars shall be flat within 0.001 in. and the angles between them shall deviate from  $90^\circ$  by no more than  $\pm 1^\circ$ .

A1.2.2 The specimens shall be obtained from the forging after final heat treatment for mechanical properties, at locations designated by the purchaser.

A1.2.3 Care shall be taken to avoid the introduction of mechanical strains during removal of the specimens from the forging and during preparation for testing.

### A1.3 Procedure

A1.3.1 The standard test data obtained shall consist of corresponding values of flux density and magnetic field strength at suitable intervals within the range of values agreed upon between the manufacturer and the purchaser.

A1.3.2 Normally, test values shall be reported in both cgs and inch-pound units at 100, 200, 400, 600, 800, 1000, 1500, 2000, and 2500 Oe in tabular form. If only one point is reported, it shall be at 100 Oe.

### A1.4 Accuracy

A1.4.1 The accuracy of test is that prescribed in Section 12 for the test method and quality of instrumentation.

### A1.5 Report

A1.5.1 When a report is required, it shall include the following information:

A1.5.1.1 Dimensions and type of specimen used.

A1.5.1.2 Any modifications of apparatus or permeameter.

A1.5.1.3 Calibration procedure used.

A1.5.1.4 Test results in both metric and inch-pound units.

## A2. CALIBRATION OF BALLISTIC GALVANOMETER (CUSTOMARY UNITS)

A2.1 The galvanometer scale and *B*-circuit may be calibrated using current reversals in the mutual inductor. The following equation shall be used to determine the calibration values:

$$I_c = BNA/(L_m \times 10^5) \quad (\text{A2.1})$$

where:

$I_c$  = current in units of Amperes required for reversal in the primary of the mutual inductor  $L_m$  to calibrate the B-circuit for a desired deflection;

$B$  = flux density in units of Gausses in the test specimen at calibrated deflection,  $\bar{G}$ ,  $\underline{G}$ ;

$N$  = number of turns in *B*-sensing coil  $N_2$  of Fig. 1-1;

$A$  = cross-sectional area of test specimen,  $\text{cm}^2$ ; and

$L_m$  = value of calibrating mutual inductance in units of millihenries.

A2.1.1 The equation can also be written as:

$$I_c = \phi N/(L_m \times 10^5) \quad (\text{A2.2})$$

where:

$\phi$  =  $BA$  or total magnetic flux, maxwells.

A2.2 Using the above equations, substitute in the value of flux density,  $B$ , which corresponds to the desired calibration flux density and the values of the specimen area turns and mutual inductance. This gives the value of current which must be reversed in the mutual inductor. Set this value of current through the mutual inductor and observe the galvanometer deflection on current reversal. The value of the calibrating resistor is then adjusted to make the galvanometer deflection on current reversal swing from zero to the desired scale deflection for the calibrated deflection point. Usually the scale is calibrated to make the deflections on reversal equal to the  $B$  value of calibration or some simple multiple of it.

A2.3 For basic material evaluation, the galvanometer shall be calibrated with sufficient number of current values to provide a

calibration curve which is accurate to 0.1 % of full scale or 0.2 % of smallest scale division. When desired because of nonlinearity or other reasons, the test deflection points may be calibrated independently without completing a full-scale calibration.

## APPENDIXES

### (Nonmandatory Information)

#### X1. MUTUAL INDUCTOR CONSTRUCTION

X1.1 A standardized mutual inductor for calibrating the galvanometer is required. It should have mutual inductance between 10 to 100 mH and be able to carry a continuous current of at least 1 A in the primary winding without appreciable heating.

NOTE X1.1—If a mutual inductor must be constructed, the following specifications will provide an inductor of approximately 50 mH. A layer of insulating material should be provided between primary and secondary windings and the foundation forms should be constructed from nonmagnetic nonconducting materials.

Part	Specifications
— Tubular winding form	— 4-in. outside diameter by 3 1/2-in. inside diameter by 2-in. length
— Tubular winding form	— 4-in. outside diameter by 3 1/2-in. inside diameter by 2-in. length
— Two end disks	— each 1/4 in. thick by 7 1/2-in. diameter
— Two end disks	— each 1/4 in. thick by 7 1/2-in. diameter
— Bottom (primary) winding	— 50 turns of No. 18 single cotton-covered enameled wire
— Top (secondary) winding	— 530 turns of No. 18 single cotton-covered enameled wire

For detailed construction of 2 precision inductor, see National Institute for Standards and Technology Circular No. 74, p. 269.

#### X2. AIR-FLUX COMPENSATION FOR B-SENSING COIL (CUSTOMARY UNITS)

X2.1 **Air-Flux Correction and Automatic Compensation**—In the ballistic test method, the flux densities are measured by means of an exploring or **B-coil** which surrounds the test specimen. In general, the mean cross section of the **B-coil** in a permeameter is considerably larger than the cross-sectional area of the test specimen. At high flux densities, a very appreciable amount of flux passes through this coil but remains outside of the test specimen. In order to obtain the correct average flux density in the test specimen, this airleakage flux must be subtracted from the total measured flux. This is readily done by means of the following equation:

$$B_{\text{true}} = B_{\text{obs}} - K\Gamma_m H \quad (\text{X2.1})$$

$$B_{\text{true}} = B_{\text{obs}} - K\Gamma_m H \quad (\text{X2.1})$$

where:

- $B_{\text{true}}$  = true flux density in the test specimen,  $\text{G}$ ,  $\text{G}$ ;
- $B_{\text{obs}}$  = observed or apparent flux density,  $\text{G}$ ,  $\text{G}$ ;
- $H$  = applied magnetic field strength,  $\text{Oe}$ ,  $\text{Oe}$ ;
- $K$  =  $(a - A)/A^2$ ;
- $a$  = mean cross section of the test coil,  $\text{cm}^2$ ,  $\text{cm}^2$ ;
- $A$  = cross section of the test specimen,  $\text{cm}^2$ , and
- $\Gamma_m$  = magnetic constant of free space, (in cgs system  $\Gamma_m = 1$ ).

X2.2 For small test specimens or for laminated material, the cross section,  $A$ , is best determined from the weight and density of the specimen. The **B-coil** cross section,  $a$ , may be calculated from the dimensions of the coil or, better, measured by placing the coil in a known magnetic field produced by a solenoid or other convenient means and then determining the linkages ballistically, from which the area may be calculated.

X2.3 For hysteresis loops, the method is similar. Assume that the flux densities are always determined from the tip,  $B_m$ , of the loop.  $B_m$  is determined as a point on the normal induction curve and is the true  $B_m$ , namely, corrected for air-leakage flux. Then, any point on the loop equals:

$$B_{\text{true}} = B_m - [\Delta B_{\text{obs}} - \Gamma_m K (H_m \pm \Delta H)] \quad (\text{X2.2})$$

$$B_{\text{true}} = B_m - [\Delta B_{\text{obs}} - \Gamma_m K (H_m - \pm \Delta H)] \quad (\text{X2.2})$$

where  $\Delta B_{\text{obs}}$  is the apparent change in flux density. ~~It should be noted~~ Note that for negative values of  $H$ ,  $H_m$ , and  $\Delta H$  are added numerically. The equation may be written, if desired:

$$B_{\text{true}} = B_m - [\Delta B_{\text{obs}} - K\Gamma_m H] \quad (\text{X2.3})$$

$$B_{\text{true}} = B_m - [\Delta B_{\text{obs}} - K\Gamma_m H] \quad (\text{X2.3})$$

X2.4 If preferred, the compensation for air-leakage flux may be made automatically in the case of ring tests and for certain types of permeameters such as the Burrows permeameter. For illustration, consider the application of an automatic compensator to the Burrows permeameter. For this permeameter,  $H$  is proportional to the main magnetizing current, since the reluctance of the yokes and joints is compensated for by means of other windings. Suppose that the main magnetizing current passes through the primary of a variable mutual inductor the secondary of which is in series opposing to the ~~B-coil~~ B coil. Assume that the mutual inductance is so adjusted that when the primary current is reversed, an emf will be generated in the secondary just equal to that generated in the ~~B-coil due to~~ B coil as a result of the air-leakage flux, namely, the linkages of the mutual inductance ( $\text{mH} \times 10^{-5}$ ) are equal to the air-leakage flux between the test specimen and ~~B-~~ B= coil. *Under this condition, the values indicated by the flux integrator will be the true induction values, since the correction for air-leakage flux is proportional to  $H$ .*

X2.5 In the case of the Burrows permeameter, saturation, and some other permeameters, an automatic compensator is used which is a variable mutual inductor having various taps so adjusted that when the dial to which the taps are connected is set to correspond to the mass of the test specimen, the air-leakage flux compensation is automatically made. This makes it possible to obtain  $H$  values corresponding to different  $B$  values without any calculations and without plotting curves and interpolating. This is of especial value in commercial testing. If desired, the automatic compensator may be set so that  $B_i$  or intrinsic flux density instead of  $B$  will be read. The method is to increase the mutual-inductance value to correspond to the total area of the ~~B-coil~~ B coil instead of the difference between the search-coil area and the test specimen area.

X2.6 **Variable Mutual Inductor**—A variable mutual inductor having a long range and an accuracy of setting of 0.1 % or better may be used. One type consists of two concentric nonconducting nonmagnetic cylinders about 6 in. in diameter and so arranged that the inside one, which carries the secondary winding, may be moved up and down by means of a centrally located screw. This screw carries a pointer for reading fractions of a revolution and on the inside cylinder another pointer which passes over a vertical scale, thus giving the revolutions. Taps are brought out from the primary winding on the outside cylinder ~~in order~~ to give various ranges. As ordinarily constructed, a range of from 0.1 to 75 mH is obtained.<sup>6</sup> It may be used with calibration curves to measure  $B$  or by establishing a test current then reversing to obtain a balance from zero  $B$  deflection after the  $B$  circuit is calibrated. It is possible to compensate for all air flux and permit direct  $B_i$  measurements when all this is done before a test specimen is inserted in the permeameter.

<sup>6</sup> For a complete description of this inductometer, see National Institute for Standards and Technology Scientific Paper 117, SPBTA.

### X3. HYSTERESIS LOSS AND ENERGY PRODUCT CALCULATION (CUSTOMARY UNITS)

X3.1 A hysteresis loop and the magnetization curve corresponding to it are shown in Fig. X3.1. For a short distance at the higher flux densities it will be noted that the magnetization curve lies outside of the loop. This is more often the case than not, although text books generally show the curve well inside of the loop. No satisfactory explanation of this effect has been found, although several have been suggested.

NOTE X3.1—Only normal or symmetrical hysteresis loops will be considered in this appendix.

X3.2 **Characteristics**—There are several characteristics of the hysteresis loop which are of use in classifying magnetic materials. These characteristics in general vary with the maximum flux density,  $B_m$ , according to some more or less definite laws.

X3.2.1 The residual induction,  $B_r$ , is the flux density in the material when the magnetic field strength has been reduced to zero. This means that not only shall there be no external magnetic field strength, but that also there shall be no demagnetizing force ~~due to~~ as a result of variations in the magnetic circuit. These conditions can be met by a ring specimen of homogeneous material and uniform cross section.

X3.2.2 The coercive force,  $H_c$ , is the demagnetizing force necessary to bring the flux density in the material to zero. This factor is closely associated with the hysteresis loss, since it determines the width of the loop. It is of very great importance in permanent magnets, because it opposes the demagnetizing forces and therefore controls the stability of the material under external magnetic influences. For electrical sheet, it is desirable to have the coercive force as small as possible, and for permanent magnets, the

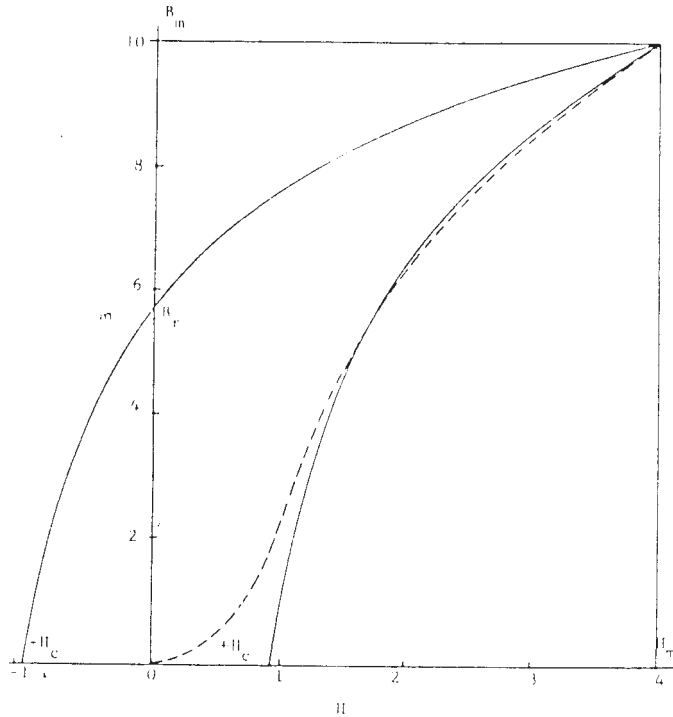

**FIG. X3.1 Magnetization Curve and Upper Half of Hysteresis Loop  
(Arbitrary Units)**

coercive force should be as large as possible.

X3.2.3 The hysteresis loss is proportional to the area of the hysteresis loop. When the flux density is plotted in gaussses and the magnetic field strength in oersteds, the hysteresis loss is equal to

$$W_h = KA/4\pi \tag{X3.1}$$

$$W_h = KA/4\pi \tag{X3.1}$$

where:

$W_h$  = the hysteresis loss in ergs/cm<sup>3</sup>/cycle,

$K$  = a constant and is numerically equal to the product of the gaussses per unit of ordinate and oersteds per unit of abscissae, and

$A$  = the area of the loop expressed in the same units as  $K$ .

For instance, if 1 cm of ordinate corresponds to 2000 G, and 1 cm of abscissae to 5 Oe<sub>2</sub> and the area of the loop as obtained by planimeter or some other convenient means is 20 cm<sup>2</sup>, the loss will be:

$$\begin{aligned} W_h &= (2\,000 \times 5 \times 20)/4\pi \\ &= 15\,900 \text{ ergs/cm}^3/\text{cycle} \end{aligned} \tag{X3.2}$$

$$\begin{aligned} W_h &= (2000 \times 5 \times 20)/4\pi \\ &= 15\,900 \text{ ergs/cm}^3/\text{cycle} \end{aligned} \tag{X3.2}$$

If it is desired to convert this to watts per kilogram for some definite frequency  $f_2$  multiply as follows:

$$W_h \times (10^{-4}f/\delta) = \text{W/kg}, \tag{X3.3}$$

$$W_h \times (10^{-4}f/\delta) = \text{W/kg} \tag{X3.3}$$

where:

$f$  = frequency, Hz (cycles per second), and

$\delta$  = density, g/cm<sup>3</sup>.

X3.2.4 In evaluating a material for use in permanent magnets, the chief interest is the demagnetization curve between  $B_r$  and  $H_c$ .

X3.2.5 In addition to the characteristics already mentioned, the product of  $B_r$  and  $H_c$  is considered by many investigators and designers to be of prime importance in determining the value of a permanent magnet. Great importance is also given to the

maximum value of the product of  $B$  and  $H$  for the demagnetization curve. A curve showing the product of these two factors is given in Fig. X3.2. This product may be called  $B_d H_d$  and the shape of the  $B_d H_d$  curve gives the available magnetic energy for exploitation in the design of permanent magnetic devices.

#### X4. EXTRAPOLATION OF MAGNETIC FIELD STRENGTH FROM $H$ - COIL POSITION TO TEST SPECIMEN SURFACE

X4.1 Scope—This appendix covers the method of extrapolation to be used when the  $H$ -coil and test specimen are situated in different levels in the same magnetizing field.

X4.2 The flux density in air is measured by the  $H$ -coil as flux density,  $B_d$ , in gauss. This flux density when divided by  $\Gamma_m$ , the magnetic constant of free space, equals magnetic field strength  $H$  in oersteds (in cgs system  $\Gamma_m = 1$  or  $B = \Gamma_m H$  (see Appendix X5)).

X4.3 In order to extrapolate  $H$ -coil measurements properly to the surface of the specimen several  $H$  (see Appendix X5).

X4.3 To extrapolate measurements will be required with known coil positions relative to the test specimen surface. The measured values of  $H$  are then plotted versus distance from the specimen surface. This curve, which is frequently exponential in shape, is then extrapolated to the specimen surface to obtain  $H$  in coil measurements properly to the test specimen.

X4.4 When one  $H$ -coil at one position is used for extrapolation or measurement surface of  $H$  in the test specimen, the field gradient or percentage variation in magnetic field, over the space between specimen surface and several  $H$ -coil and along the length of the specimen and  $H$ -coil must be considerably smaller than the permissible error in measurement of magnetic field strength,  $H$  measurements will be required with known coil positions relative to the test specimen surface. The measured values of  $H$  are then plotted versus distance from the specimen surface. This curve, which is frequently exponential in shape, is then extrapolated to the specimen surface to obtain  $H$  in the test specimen.

X4.4 When one  $H$  coil at one position is used for extrapolation or measurement of  $H$  in the test specimen, the field gradient or percentage variation in magnetic field, over the space between specimen surface and  $H$  coil and along the length of the specimen and  $H$  coil must be considerably smaller than the permissible error in measurement of magnetic field strength,  $H$ .

#### X5. USE OF FLIP $H$ COILS OR HALL-EFFECT DEVICES FOR MEASUREMENT OF MAGNETIC FIELD STRENGTH IN PERMEAMETERS

##### X5.1 Scope

X5.1.1 This appendix covers the use of flip  $H$ - coils and Hall-effect devices or other localized field- measuring devices for determination of magnetic field strength in a test specimen under test in a permeameter.

X5.1.2 Although applying specifically to the dc ballistic test methods, this appendix also applies to any test method using permeameters. It is used in conjunction with Practice A 34/A 34M and applies to the test methods outlined in that standard.

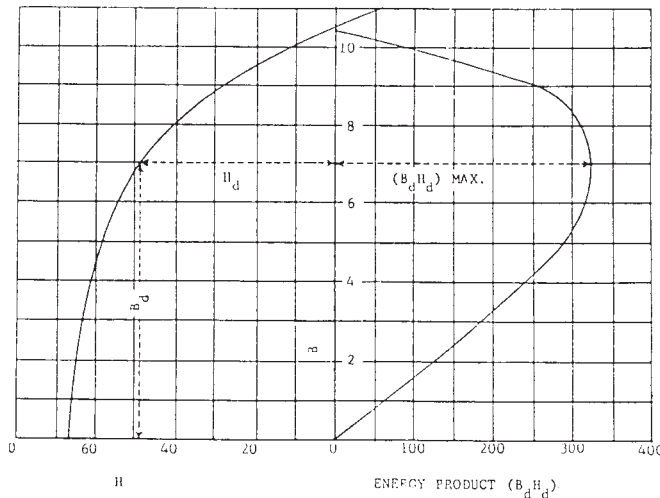

**FIG. X3.2 Demagnetization Curve and Energy Product for Permanent Magnet Material**

## X5.2 Summary

X5.2.1 When testing accuracy is of paramount importance, use of the flip  $H$ - coil or Hall-effect devices should be considered since they have a distinct accuracy advantage over the fixed  $H$ - coil.

X5.2.2 By proper measurement and extrapolation, these devices can determine with a high degree of accuracy the average field value at the surface of the test specimen.

X5.2.3 In most permeameters, there are steep field gradients in the space surrounding a test specimen. These gradients are present in both a radial direction and in a longitudinal direction parallel to the sample length. In order to average and extrapolate properly, enough measurements must be made to represent satisfactorily the field gradient situation in both the radial and longitudinal directions.

## X5.3 Flip $H$ - Coil

X5.3.1 The flip  $H$ - coil is essentially a standard  $H$ - coil which may be rotated at a constant radial speed through an angle of  $180^\circ$ . The center of rotation is the geometric center of the  $H$ - coil so that the two ends replace each other in physical position relative to the test specimens.

X5.3.2 The flip  $H$ - coil is an averaging device and averages out the effects of longitudinal field gradients.

X5.3.3 The flip  $H$ - coil has the same limitations, but to a lesser degree than the fixed  $H$ - coil when used in permeameters having large longitudinal field gradients. In these permeameters, the length of the  $H$ - coil or flip  $H$ - coil should be as nearly as possible the same length as the  $B$ - coil and physically should cover, or be located adjacent to, the same parts of the test specimens.

X5.3.4 Since field gradients in the radial direction are seldom linear, it is necessary to have three or more flip  $H$ - coils located at known distance from the test specimen surfaces. This permits a curve to be plotted with field intensity versus distance which can then be extrapolated to the specimen surface (Appendix X4).

## X5.4 Hall-effect or Other Point-Field Measuring Devices

X5.4.1 Hall-effect or other small-volume sensing element devices essentially measure field at a point in space. For this reason, when they are used as field measuring devices with permeameters, the  $H$  value must be determined at three or more positions along the active test specimen length. At each of these positions three or more measurements must be made at different distances from the test specimens. A curve is then plotted for each position and is extrapolated to the specimen surface (Appendix X4). The  $H$  values at the specimen surface for these three positions are then averaged to determine the effective value of the field in the test specimen.

X5.4.2 When considerable error may be tolerated, the Hall probe is placed as close as possible to the specimen and is moved along the specimen from end to end. The field readings are visually averaged and reported as one value

## X6. ARC SUPPRESSION FOR DIRECTLY SWITCHED TEST UNITS

X6.1 The high sensitivity of electronic integrators renders them more susceptible to noise-induced error than ballistic galvanometers or moving coil fluxmeters. One potentially significant source of noise is arcing across the contacts of the current reversing switch  $S_1$  shown in Fig. 1. Such arcing is favored by use of a large number of magnetizing turns. If the magnitude and duration of the arc and the transients in the secondary winding are significant, the integrator output will be incorrect.

X6.2 The magnitude of this integrator error can be established by moving the position of  $S_1$  from one side to the other, waiting until the integrator reading stabilizes, and then moving  $S_1$  back to its original position. The amount by which the fluxmeter output changes at the completion of this cycle, less the amount due to caused by integrator drift, is indicative of the magnitude of the error to be expected in normal use. If this difference can be attributed to arc noise and not to differences in contact resistance and if the magnitude is unacceptable, the techniques described in X6.3 through X6.5 should be used to reduce this error to an acceptable level.

X6.3 The sudden interruption of the current flowing in the magnetizing winding can cause the voltage across the winding to become very large, producing arcing at the contacts of  $S_1$ . If the magnetizing current were allowed to decay at a slower rate, the voltage across the magnetizing winding would be much lower, and the arcing would be reduced accordingly. This can be accomplished by placing a diode bridge with capacitor ( $D_1, D_2, D_3, D_4$ )C across the magnetizing winding as shown in Fig. X6.1. The diode bridge and capacitor provide a path for the discharge of the stored magnetic energy. The capacitance required depends on the impedance of the power supply and resistors  $R_1$  and  $R_2$  in Fig. 1. The lower these impedances are, the smaller is the capacitance required to reduce arcing.

X6.4 Arc-generated noise can also be reduced by use of a relay with magnetic arc suppression or with mercury-wetted contacts in place of a manually operated switch. However, the use of the diode bridge and capacitor further reduces this noise.

X6.5 All transients and arcing conditions can be eliminated by use of remotely programmed bipolar power supplies thereby eliminating the use of the current reversing switch.

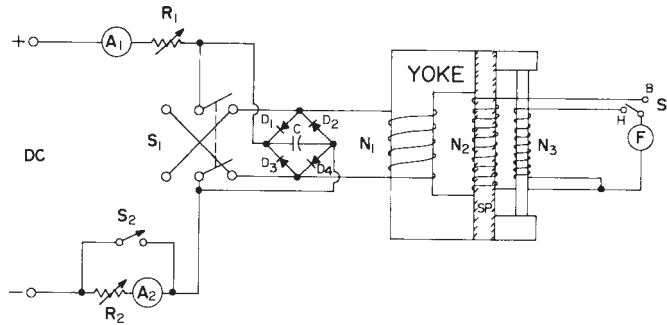

FIG. X6.1 Schematic Illustration of Arc Suppression Diode Bridge Placed in the Circuit Shown Previously in Fig. 1

## REFERENCES

- (1) Harris, F. K., *Electrical Measurements*, John Wiley and Sons, Inc., New York, NY, 1952.
- (2) Babbit, B. J., "An Improved Permeameter for Testing Magnet Steel," *Journal of the Optical Society and Review of Scientific Instruments*, Vol 17, 1928, p. 47.
- (3) Burrows, C. W., "The Determination of the Magnetic Induction in Straight Bars," *Bulletin, National Bureau of Standards*, Vol 6, 1909, p. 31 (S117).
- (4) Spooner, Thomas, *Properties and Testing of Magnetic Materials*, McGraw-Hill Book Co., New York, NY, 1927.
- (5) Sanford, R. L., "Magnetic Testing," Circular No. C456, National Institute for Standards and Technology, 1946.
- (6) Sanford, R. L., "Performance of Fahy Simplex Permeameter," *Journal of Research, National Institute for Standards and Technology*, Vol 4, No. 5, May 1930, p. 703 (RP174).
- (7) Sanford, R. L., and Cooter, I. L., "Basic Magnetic Quantities and the Measurement of the Magnetic Properties of Materials," Monograph 47, National Institute for Standards and Technology, 1962.
- (8) Smith, B. M., "A New Full-Range Permeameter," *General Electric Review*, November Nov. 1935, Vol 38, No. 11, p. 196.
- (9) Sanford, R. L., and Bennett, E. G., "An Apparatus for Magnetic Testing at Magnetizing Forces up to 5000 Oersteds," *Journal of Research, National Institute for Standards and Technology*, Vol 23, 1939, p. 415 (RP1242).
- (10) Iliovici, M. A., *Bulletin de la Societe Internationale des Electriciens*, Vol 3, 1913, p. 581.
- (11) Astbury, N. F., *Industrial Magnetic Testing*, Institute of Physics, London, 1952.
- (12) Cheney, W. L., "Magnetic Testing of Straight Rods in Intense Fields," *Scientific Paper No. 361, National Institute for Standards and Technology*, 1920.
- (13) Cheney, W. L., "Measurement of Hysteresis Values from High Magnetizing Forces," *Scientific Paper No. 383, National Institute for Standards and Technology*, 1920.
- (14) Sanford, R. L., and Winter, P. H., "Permeameter for Magnetic Testing at Magnetizing Forces up to 300 Oersteds," *Journal of Research, National Institute for Standards and Technology*, Vol 45, 1950, p. 17 (RP2109).
- (15) Webb, C. E., and Ford, L. H., "Precision Permeability Measurements on Straight Bars and Strips in the Region of High Permeability," *Journal of Institution of Electrical Engineers.*, Vol 67, 1929, p. 1302.
- (16) Gokhale, S. L., "The Saturation Permeameter," *Journal of American Institute of Electrical Engineers.*, Vol 47, 1928, p. 196.
- (17) Gokhale, S. L., U.S. Patent No. 1,559,085 (Permeameter).
- (18) Lloyd, M. G., "Errors in Magnetic Testing with Ring Specimens," *Bulletin, National Institute for Standards and Technology*, Vol 5, 1909, p. 435 (S108).

ASTM International takes no position respecting the validity of any patent rights asserted in connection with any item mentioned in this standard. Users of this standard are expressly advised that determination of the validity of any such patent rights, and the risk of infringement of such rights, are entirely their own responsibility.

This standard is subject to revision at any time by the responsible technical committee and must be reviewed every five years and if not revised, either reapproved or withdrawn. Your comments are invited either for revision of this standard or for additional standards and should be addressed to ASTM International Headquarters. Your comments will receive careful consideration at a meeting of the responsible technical committee, which you may attend. If you feel that your comments have not received a fair hearing you should make your views known to the ASTM Committee on Standards, at the address shown below.

This standard is copyrighted by ASTM International, 100 Barr Harbor Drive, PO Box C700, West Conshohocken, PA 19428-2959, United States. Individual reprints (single or multiple copies) of this standard may be obtained by contacting ASTM at the above address or at 610-832-9585 (phone), 610-832-9555 (fax), or service@astm.org (e-mail); or through the ASTM website (www.astm.org).