



Standard Test Method for Alternating-Current Magnetic Properties of Materials at Power Frequencies Using Wattmeter-Ammeter-Voltmeter Method and 25-cm Epstein Test Frame¹

This standard is issued under the fixed designation A 343/A 343M; the number immediately following the designation indicates the year of original adoption or, in the case of revision, the year of last revision. A number in parentheses indicates the year of last reapproval. A superscript epsilon (ε) indicates an editorial change since the last revision or reapproval.

1. Scope

1.1 This test method covers tests for the magnetic properties of basic flat-rolled magnetic materials at power frequencies (25 to 400 Hz) using a 25-cm Epstein test frame and the 25-cm double-lap-jointed core. It covers the determination of core loss, rms exciting power, rms and peak exciting current, and several types of ac permeability and related properties of flat-rolled magnetic materials under ac magnetization.

1.2 This test method shall be used in conjunction with Practice A 34/A 34M.

1.3 This test method² provides a test for core loss and exciting current at moderate and high magnetic flux densities up to 15 kG [1.5 T] on nonoriented electrical steels and up to 18 kG [1.8 T] on grain-oriented electrical steels.

1.4 The frequency range of this test method is normally that of the commercial power frequencies 50 to 60 Hz. With proper instrumentation, it is also acceptable for measurements at other frequencies from 25 to 400 Hz.

1.5 This test method also provides procedures for calculating ac impedance permeability from measured values of rms exciting current and for ac peak permeability from measured peak values of total exciting currents at magnetic field strengths up to about 150 Oe [12 000 A/m].

1.6 Explanation of symbols and abbreviated definitions appear in the text of this test method. The official symbols and definitions are listed in Terminology A 340.

1.7 The values and equations stated in either customary (cgs-emu and inch-pound) or SI units are to be regarded separately as standard. Within this standard, SI units are shown in brackets except in the sections concerning calculations where there are separate sections for the respective unit systems. The values stated in each system may not be exact equivalents; therefore, each system shall be used independently

of the other. Combining values from the two systems may result in nonconformance with this standard.

1.8 *This standard does not purport to address all of the safety concerns, if any, associated with its use. It is the responsibility of the user of this standard to establish appropriate safety and health practices and determine the applicability of regulatory limitations prior to use.*

2. Referenced Documents

2.1 ASTM Standards:

A 34/A 34M Practice for Sampling and Procurement Testing of Magnetic Materials³

A 340 Terminology of Symbols and Definitions Relating to Magnetic Testing³

A 677/A 677M Specification for Nonoriented Electrical Steel Fully Processed Types³

A 683/A 683M Specification for Nonoriented Electrical Steel, Semiprocessed Types³

A 876/A 876M Specification for Flat-Rolled, Grain-Oriented, Silicon-Iron, Electrical Steel, Fully Processed Types³

A 889/A 889M Test Method for Alternating-Current Magnetic Properties of Materials at Low Inductions Using the Wattmeter-Varmeter-Ammeter-Voltmeter Method and 25-cm (250-mm) Epstein Frame³

E 177 Practice for Use of the Terms Precision and Bias in ASTM Test Methods⁴

E 691 Practice for Conducting an Interlaboratory Study to Determine the Precision of a Test Method⁴

E 1338 Guide for the Identification of Metals and Alloys In Computerized Material Property Databases⁵

3. Significance and Use

3.1 This test method is a fundamental method for evaluating the magnetic performance of flat-rolled magnetic materials in either as-sheared or stress-relief annealed condition.

3.2 This test method is suitable for design, specification acceptance, service evaluation, and research and development.

¹ This test method is under the jurisdiction of ASTM Committee A06 on Magnetic Properties and is the direct responsibility of Subcommittee A6.01 on Test Methods.

Current edition approved June 10, 2003. Published July 2003. Originally approved in 1949. Last previous edition approved in 1997 as A 343 – 97.

² See Burgwin, S. L., "Measurement of Core Loss and A-C Permeability with the 25-cm Epstein Frame," *Proceedings*, American Society for Testing and Materials, ASTEA Vol 41, 1941, p. 779.

³ *Annual Book of ASTM Standards*, Vol 03.04.

⁴ *Annual Book of ASTM Standards*, Vol 14.02.

⁵ *Annual Book of ASTM Standards*, Vol 02.05.

4. Test Specimens

4.1 The specimens for this test shall be selected and prepared for testing in accordance with provisions of Practice A 34/A 34M and as directed in Appendix of this test method.

5. Basic Circuit

5.1 Fig. 1 shows the essential apparatus and basic circuit connections for this test method. Terminals 1 and 2 are connected to a source of adjustable ac voltage of sinusoidal waveform and sufficient power rating to energize the primary circuit without appreciable voltage drop in the source impedance. All primary circuit switches and all primary wiring should be capable of carrying much higher currents than are normally encountered to limit primary circuit resistance to values that will not cause appreciable distortion of the flux waveform in the specimen when relatively nonsinusoidal currents are drawn. The ac source may be an electronic amplifier which has a sine-wave oscillator connected to its input and may include the necessary circuitry to maintain a sinusoidal flux waveform by using negative feedback of the induced secondary voltage. In this case, higher primary resistance can be tolerated since this system will maintain sinusoidal flux at much higher primary resistance. Although the current drain in the secondary is quite small, especially when using modern high-input impedance instrumentation, the switches and wiring should be selected to minimize the lead resistance so that the voltage available at the terminals of the instruments is imperceptibly lower than the voltage at the secondary terminals of the Epstein test frame.

6. Apparatus

6.1 The apparatus shall consist of as many of the following component parts as are required to perform the desired measurement functions:

6.2 Epstein Test Frame:

6.2.1 The test frame shall consist of four solenoids (each having two windings) surrounding the four sides of the square magnetic circuit, and a mutual inductor to compensate for air flux within the solenoids. The solenoids shall be wound on nonmagnetic, nonconducting forms of rectangular cross section appropriate to the specimen mass to be used. The solenoids shall be mounted so as to be accurately in the same horizontal plane, and with the center line of solenoids on opposite sides of the square, 250 ± 0.3 mm apart. The compensating mutual inductor may be located in the center of the space enclosed by the four solenoids if the axis of the inductor is made to be perpendicular to the plane of the solenoid windings.

6.2.2 The inner or potential winding on each solenoid shall consist of one fourth of the total number of secondary turns evenly wound in one layer over a winding length of 191 mm or longer of each solenoid. The potential windings of the four solenoids shall be connected in series so their voltages will add. The outer or magnetizing winding likewise shall consist of one fourth of the total number of primary turns evenly wound over the winding length of each solenoid. These individual solenoid windings, too, shall be connected in series so their magnetic field strengths will add. The primary winding may comprise up to three layers using two or more wires in parallel.

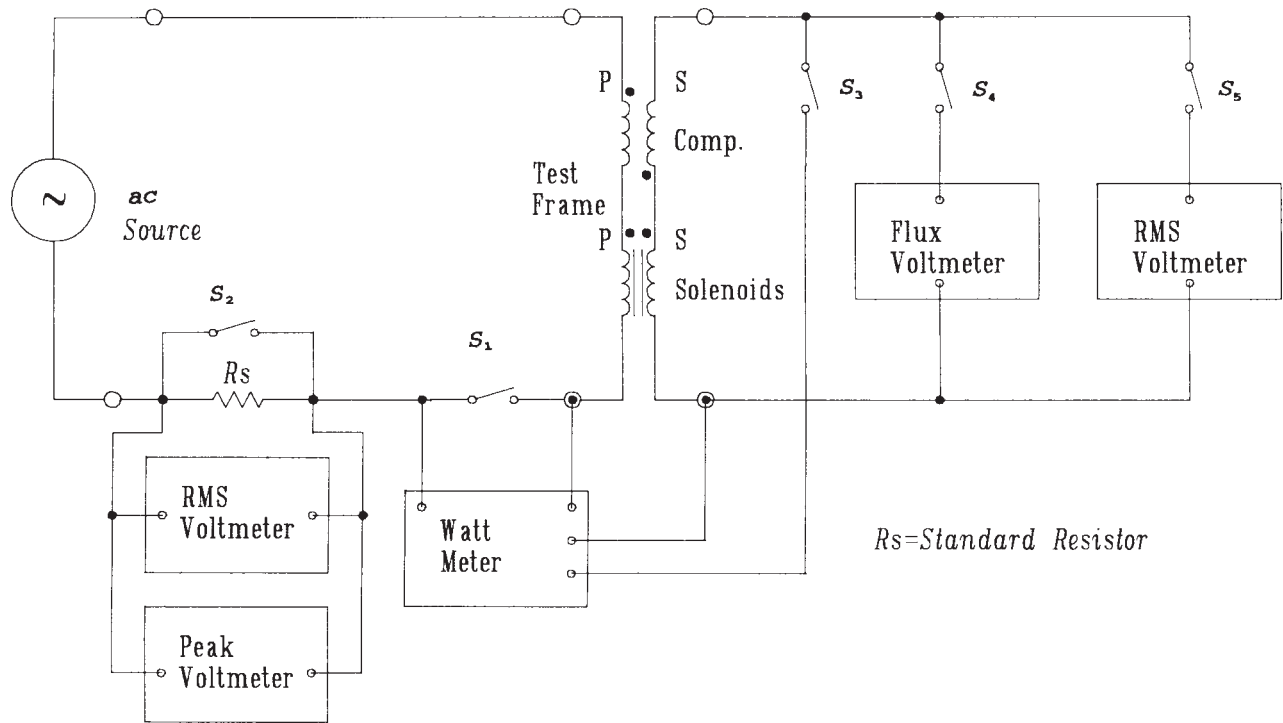

FIG. 1 Basic Circuit for Wattmeter-Ammeter-Voltmeter Method

6.2.3 Primary and secondary turns shall be wound in the same direction, with the starting end of each winding being at the same corner junction of one of the four solenoids. This enables the potential between adjacent primary and secondary turns to be a minimum throughout the length of the winding, thereby reducing errors as a result of electrostatic phenomena.

6.2.4 The solenoid windings on the test frame may be any number of turns suited to the instrumentation, mass of specimen, and test frequency. Windings with a total of 700 turns are recommended for tests in the frequency range of 25 through 400 Hz.

6.2.5 The mutual inductance of the air-flux compensating inductor shall be adjusted to be the same as that between the test-frame windings to within one turn of the compensator secondary. Its windings shall be connected in series with the corresponding test-frame windings so that the voltage induced in the secondary winding of the inductor by the primary current will completely oppose or cancel the total voltage induced in the secondary winding of the test frame when no sample is in place in the solenoids. Specifications for the approximate turns and construction details of the compensating mutual inductor for the standard test frame are given in Table A1.1 of Annex A1.

6.3 *Flux Voltmeter, V_f* —A full-wave true-average, voltmeter, with scale reading in average volts times $\sqrt{2} \pi/4$ so that its indications will be identical with those of a true rms voltmeter on a pure sinusoidal voltage, shall be provided for evaluating the peak value of the test magnetic flux density. To produce the estimated precision of test under this test method, the full-scale meter errors shall not exceed 0.25 % (Note 1). Meters of 0.5 % of more error may be used at reduced accuracy. Either digital or analog flux voltmeters are permitted. The normally high-input impedance of digital flux voltmeters is desirable to minimize loading effects and to reduce the magnitude of instrument loss compensations. The input resistance of an analog flux voltmeter shall not be less than 1000 Ω/V of full-scale indication. A resistive voltage divider, a standard-ratio transformer, or other variable scaling device may be used to cause the flux voltmeter to indicate directly in units of magnetic flux density if the combination of basic instrument and scaling device conforms to the specifications stated above.

NOTE 1—Inaccuracies in setting the test voltage produce errors approximately two times as large in the specific core loss. Voltage scales should be such that the instrument is not used at less than half scale. Care should also be taken to avoid errors caused by temperature and frequency effects in the instrument.

6.3.1 If used with a mutual inductor as a peak ammeter at magnetic flux densities well above the knee of the magnetization curve, the flux voltmeter must be capable of accurately measuring the extremely nonsinusoidal (peaked) voltage that is induced in the secondary winding of the mutual inductor. Additionally, if so used, an analog flux voltmeter should have a minimum input resistance of 5000 Ω/V of full-scale indication.

6.4 *RMS Voltmeter, V_{rms}* —A true rms-indicating voltmeter shall be provided for evaluating the form factor of the voltage induced in the secondary winding of the test fixture and for

evaluating the instrument losses. The accuracy of the rms voltmeter shall be the same as that specified for the flux voltmeter. Either digital or analog rms voltmeters are permitted. The normally high-input impedance of digital rms voltmeters is desirable to minimize loading effects and to reduce the magnitude of instrument loss compensations. The input resistance of an analog rms voltmeter shall not be less than 5000 Ω/V of full-scale indication.

6.5 *Wattmeter, W* —The full-scale accuracy of the wattmeter must not be poorer than 0.25 % at the frequency of test and at unity power factor. The power factor encountered by a wattmeter during a core loss test on a specimen is always less than unity and, at magnetic flux densities far above the knee of the magnetization curve, approaches zero. The wattmeter must maintain adequate accuracy (1.0 % of reading) even at the most severe (lowest) power factor that is presented to it. Variable scaling devices may be used to cause the wattmeter to indicate directly in units of specific core loss if the combination of basic instrument and scaling devices conforms to the specifications stated here.

6.5.1 *Electronic Digital Wattmeter*—Electronic digital wattmeters have been developed that have proven satisfactory for use under the provisions of this test method. Usage of a suitable electronic digital wattmeter is permitted as an alternative to an electrodynamic wattmeter in this test method. An electronic digital wattmeter oftentimes is preferred in this test method because of its digital readout and its capability for direct interfacing with electronic data acquisition systems.

6.5.1.1 The voltage input circuitry of the electronic digital wattmeter must have an input impedance sufficiently high that connection of the circuitry, during testing, to the secondary winding of the test fixture does not change the terminal voltage of the secondary by more than 0.05 %. In addition, the voltage input circuitry must be capable of accepting the maximum peak voltage that is induced in the secondary winding during testing.

6.5.1.2 The current input circuitry of the electronic digital wattmeter must have an input impedance of no more than 1 Ω . Preferably the input impedance should be no more than 0.1 Ω if the flux waveform distortion otherwise tends to be excessive. In addition, the current input circuitry must be capable of accepting the maximum rms current and the maximum peak current drawn by the primary winding of the test fixture when core loss tests are being performed. In particular, since the primary current will be very nonsinusoidal (peaked) if core-loss tests are performed on a specimen at magnetic flux densities above the knee of the magnetization curve, the crest factor capability of the current input circuitry should be three or more.

6.5.2 *Electrodynamometer Wattmeter*—A reflecting-type dynamometer is recommended among this class of instruments, but, if the specimen mass is sufficiently large, a direct-indicating electrodynamic wattmeter of the highest available sensitivity and lowest power-factor capability may be used.

6.5.2.1 The sensitivity of the electrodynamic wattmeter must be such that the connection of the potential circuit of the wattmeter, during testing, to the secondary winding of the test fixture does not change the terminal voltage of the

secondary by more than 0.05 %. Also, the resistance of the potential circuit of the wattmeter must be sufficiently high that the inductive reactance of the potential coil of the wattmeter in combination with the leakage reactance of the secondary circuit of the test fixture does not result in appreciable defect angle errors in the measurements. Should the impedance of this combined reactance at the test frequency exceed 1.0Ω per 1000Ω of resistance in the wattmeter-potential circuit, the potential circuit must be compensated for this reactance.

6.5.2.2 The impedance of the current coil of the electrodynamic wattmeter should not exceed 1Ω . If flux waveform distortion otherwise tends to be excessive, this impedance should be not more than 0.1Ω . The rated current-carrying capacity of the current coil must be compatible with the maximum rms primary current to be encountered during core-loss testing. Preferably the current-carrying capacity should be at least 10 rms amperes.

6.6 *Devices for RMS Current Measurement*—A means of measuring the rms value of the exciting current must be provided if measurements of exciting power or exciting current are to be made.

6.6.1 *RMS Voltmeter and Standard Resistor*—A true rms-indicating voltmeter may be used to measure the voltage drop across the potential terminals of a standard resistance. The accuracy of the rms voltmeter shall be 1.0 % of full scale or less. Either digital or analog meters are permitted. A high-input-impedance, multirange electronic digital rms voltmeter is desirable for this instrument. The input resistance of an analog meter shall not be less than $5000 \Omega/v$. The standard resistor should be a non-inductive resistor with an accuracy rating of 0.1 % or better. This resistor must be capable of handling the full exciting current of the test winding at the maximum test magnetic flux density without destructive heating or more than specified loss of accuracy as a result of self-heating. To avoid intolerable levels of distortion, the value of the resistor should be kept reasonably low. A fixed resistor between 0.1 and 1.0Ω is usually appropriate.

6.6.2 *RMS Ammeter*—A true rms-indicating ammeter may be used to measure the exciting current. A nominal accuracy of 1.0 % of full scale or better is required for this instrument. The instrument must have low internal impedance to avoid contributing to the distortion of the flux waveform.

6.7 *Devices for Peak Current Measurement*—A means of measuring the peak value of the exciting current is required if an evaluation of peak permeability is to be made by the peak-current method.

6.7.1 *Peak-to-Peak Voltmeter and Standard Resistor*—The peak current measurement may be made with a voltmeter whose indications are proportional to the peak-to-peak value of the voltage drop across the potential terminals of a standard resistor connected in series with the primary winding of the test fixture. This peak-to-peak reading (or peak reading) voltmeter shall have a nominal full-scale accuracy of 1.0 % or better at the test frequency and shall be able to accommodate voltages with a crest factor of up to 5. The standard resistor should be a non-inductive resistor with an accuracy rating of 0.1 % or better. This resistor must be capable of handling the full exciting current of the test winding at the maximum test

magnetic flux density without destructive heating or more than specified loss of accuracy due to self-heating. To avoid intolerable levels of distortion, the value of the resistor should be kept reasonably low. A fixed resistor between 0.1 and 1.0Ω is usually appropriate.

6.7.2 *Air-Core Mutual Inductor and Flux Voltmeter*—An air-core mutual inductor and a flux voltmeter may be used to measure the peak exciting current. Use of this apparatus is based upon the same theoretical considerations that indicate the use of a flux voltmeter on the secondary of the test fixture to measure the peak magnetic flux density; namely, that when a flux voltmeter is connected to a test coil, the flux voltmeter indications are proportional to the peak value of the flux linking the coil. In the case of the air-core mutual inductor, the peak value of the flux will be proportional to the peak value of the current flowing in the primary winding. A mutual inductor used for this purpose must have reasonably low primary impedance so that its insertion will not materially affect the primary circuit conditions and have sufficiently high mutual inductance to provide a satisfactorily high voltage to the flux voltmeter for primary currents corresponding to the desired range in peak magnetic field strength. The secondary impedance of the mutual inductor must be low if any significant current is drawn by a low-impedance flux voltmeter. The addition of the flux voltmeter should not change the mutual inductor secondary terminal voltage by more than 0.25 %. It is important that the mutual inductor be located in the test equipment in such a position that its windings will not be linked by ac leakage flux from other apparatus. Care should be taken to avoid locating it so close to any magnetic material or any conducting material that its calibration and linearity may be affected. Directions for construction and calibration of a mutual inductor for peak-current measurement are given in Annex A1. Even at commercial power frequencies, there can be appreciable error in the measurement of peak exciting current if winding capacitances and inductances and flux voltmeter errors begin to become important at some of the high harmonics frequencies present because of the extremely non-sinusoidal character of the voltage waveform induced in the secondary of the mutual inductor by the nonsinusoidal exciting current waveform.

6.8 *Power Supply*—A precisely controllable source of sinusoidal test voltage of low internal impedance and excellent voltage and frequency stability is mandatory. Voltage stability within 0.1 % and frequency accuracy within 0.1 % should be maintained. Electronic power sources using negative feedback from the secondary winding of the test fixture to reduce flux waveform distortion have been found to perform quite satisfactorily in this test method.

7. Procedure

7.1 Before testing, check the specimen strips for length to see that they conform to the desired length to within $\pm 1/32$ in. [0.8 mm] (Note 2). Also check the specimen to see that no dented, twisted, or distorted strips showing evidence of mechanical abuse have been included and that the strips are of uniform width (Note 3). Strips having readily noticeable shearing burrs also may be unsuitable for testing. Weigh the specimen on a scale or balance capable of determining the

mass within an accuracy of 0.1 %. Record specimen weights of less than 1 kg to at least the nearest 0.5 g and within the nearest 1.0 g for specimens heavier than 1 kg.

NOTE 2—Inaccuracy in shearing the length of Epstein strips is equivalent to a weighing error of the same percentage. Both weight and specimen length inaccuracies cause errors in magnetic flux density measurements, which result in even greater core loss errors.

NOTE 3—The width of strips in the specimen should be checked for uniformity since nonuniform width will result in nonuniform magnetic flux density in the specimen, which may have a significant but unpredictable effect upon testing accuracy.

7.2 Divide the test specimen strips into four groups containing equal numbers of strips, and very closely the same mass, for testing. Insert the strips (always a multiple of four in number) into the test frame solenoids one at a time, starting with one strip in each of two opposite solenoids and then inserting a strip into each of the other two solenoids so that these latter strips completely overlap the former two at the four corners. This completes one layer of strips constituting a complete flux path with four overlapped joints. Build up successive layers in this same fashion until the specimen is completely assembled. With specimens cut half with and half cross grain, arrange all the parallel or “with-grain” strips in two opposite solenoids and all the cross- or transverse-grain strips in the other two opposite solenoids.

7.3 If the specimen strips are reasonably flat and have a reasonable area of contact at the corners, a sufficiently low reluctance is usually obtained without resorting to pressure on the joints. When the joints are unavoidably poor, the use of light pressure on the joints, from the use of nonmagnetic corner weights of about 200 g, is permissible although it may introduce some additional stresses in strain-sensitive materials. With certain types of magnetic material, or for correct evaluation of properties in certain magnetic flux density ranges, it may be necessary that the specimen be given a heat treatment to relieve stresses before testing. Follow the recommendations of the manufacturer of the materials in performing this operation.

7.4 *Demagnetization*—The specimen should be demagnetized before measurements of any magnetic property are made. With the required apparatus connected as shown in Fig. 1 and switches S_1 , S_2 , and S_4 closed and switches S_3 and S_5 open, accomplish this demagnetization by initially applying a voltage from the power source to the primary circuit that is sufficient to magnetize the specimen to a magnetic flux density above the knee of its magnetization curve (magnetic flux density may be determined from the reading of the flux voltmeter by means of the equations in 8.1 or 9.1), and then decrease the voltage slowly and smoothly (or in small steps) to a very low magnetic flux density. After this demagnetization, test promptly for the desired test points. When multiple test points are required, perform the tests in order of increasing magnetic flux density values.

7.5 *Setting Magnetic Flux Density*—With switches S_3 and S_4 closed and switches S_1 , S_2 , and S_5 open, increase the voltage of the power supply until the flux voltmeter indicates the value of voltage calculated to give the desired test magnetic flux density in accordance with the equations in 8.1 or 9.1. Because the action of the air-flux compensator causes a voltage equal to

that which would be induced in the secondary winding by the air flux to be subtracted from that induced by the total flux in the secondary, the magnetic flux density calculated from the voltage indicated by the flux voltmeter is the intrinsic induction, $B_i = (B - \Gamma_m H_p)$. In most cases the values of intrinsic induction, B_i , are not sufficiently different from the corresponding values of normal induction, B , to require that any distinction be made. Where $\Gamma_m H_p$ is not insignificant compared to B_i , as it is at very high magnetic flux densities, determine the value of B by adding to B_i either the measured value of $\Gamma_m H_p$ or a nominal value known to be reasonably typical of the class of material being tested.

7.6 *Core Loss*—When the voltage indicated by the flux voltmeter has been adjusted to the desired value, read the wattmeter. Some users, particularly those having wattmeters compensated for their own losses (or burden), will desire to open switch S_4 to eliminate the flux voltmeter burden from the wattmeter indication. Others will likely choose to have S_4 and S_5 closed when measuring the losses, so that all instruments may be read at the same time. In the latter case, the combined resistance load of the flux voltmeter, rms voltmeter, and potential circuit of the wattmeter will constitute the total instrument burden on the wattmeter. Exercise care so that the combined current drain of the instruments does not cause an appreciably large voltage drop in the secondary circuit resistance of the test frame. In such a case, the true magnetic flux density in the specimen may be appreciably higher than is apparent from the voltage measured at the secondary terminals of the test frame. In any event, power as a result of any current drain in the secondary circuit at the time of reading the wattmeter must be known so it can be subtracted from the wattmeter indications to obtain the net watts caused by core loss.

7.7 Obtain the specific core loss of the specimen in watts per unit mass at a specified frequency by dividing the net watts by that portion of the mass of the specimen constituting the active magnetic flux path (which is less than the mean geometric path length) in the specimen. Equations and instructions for computing the active mass of the specimen and the specific core loss are given in 8.2 and 9.2.

7.8 Measure the rms value of the secondary voltage by having both S_4 and S_5 closed and the voltage adjusted to indicate the correct value of flux volts. On truly sinusoidal voltage, both voltmeters will indicate the same voltage showing that the form factor of the induced voltage is $\sqrt{2} \pi/4$. When the voltmeters give different readings, the ratio of the rms value to that indicated by the flux voltmeter reveals the ratio by which the form factor of the induced voltage deviates from the desired value of $\sqrt{2} \pi/4$. Determining the magnetic flux density from the readings of a flux voltmeter assures that the correct value of peak magnetic flux density is achieved in the specimen, and hence that the hysteresis component of the core loss is correct even if the waveform is not strictly sinusoidal. But the eddy-current component of the core loss, being caused by current resulting from a nonsinusoidal voltage induced in the cross section of the strip, will be in error depending on the deviation of the induced voltage from the desired sinusoidal wave shape. This error in the eddy-current

component of loss can be readily corrected by calculations based on the observed form factor and the approximate percentage of eddy-current loss for the grade of material being tested if the correction is reasonably small. The equations involved in determining this correction are given in 8.3 and 9.3.

7.9 RMS Exciting Current—Measure the rms exciting current, when required, by having S_1 and S_4 closed; S_2 , S_3 , and S_5 open; then with the ammeter on a suitable scale range, adjust the voltage to the correct flux voltmeter indication for the desired test magnetic flux density. When the setting of voltage is correct, open S_4 and read the ammeter with no current drain in the secondary circuit. If S_4 is kept closed to monitor the magnetic flux density during the current reading, the current drain of the flux voltmeter will be included in the ammeter indication. If exciting current is to be reported in terms of ampere-turns per unit path length, volt-amperes per unit mass, or permeability from impedance, calculate the values of these parameters from the equations of 8.4 and 9.4.

7.10 Permeability—When permeability from peak exciting current is required, determine the peak value of exciting current using the peak-reading voltmeter and standard resistor. Switch S_1 should be closed to protect the wattmeter from the possibility of excessive current. Switches S_3 and S_5 should be open to minimize secondary loading. With switch S_2 open and S_5 closed, adjust the voltage to the correct value for the desired magnetic flux density or the correct value of peak current for the desired magnetic field strength. Equations involved in the determination of peak magnetic field strength using a peak-reading voltmeter are given in 8.6 and 9.6.

7.11 If the mutual inductor and flux voltmeter are used to determine peak current rather than the standard resistor and peak-reading voltmeter, follow the same procedure as in 7.10. The flux voltmeter used for this purpose must meet the restrictions of 6.7.2. Equations involved in the determination of peak magnetic field strength using a mutual inductor and flux voltmeter are given in 8.6 and 9.6.

8. Calculation (Customary Units)

8.1 Calculate the value of the flux voltage E_f at the desired test magnetic flux density in the specimen (when corrected for flux due to H in the material and in the air space encircled by the test winding through the use of the required air-flux compensator) in accordance with the following basic equation discussed in X1.2 of this test method:

$$E_f = \sqrt{2} \pi B_i A N_2 f 10^{-8} \quad (1)$$

where:

- B_i = maximum intrinsic flux density, G;
- A = effective cross-sectional area of the test specimen, cm²;
- N_2 = number of turns in secondary winding; and
- f = frequency, Hz.

8.1.1 In the case of Epstein specimens, where the total number of strips is divided into four equal groups comprising the magnetic circuit, the mass of the specimen in each of the four legs of the magnetic circuit becomes $m/4$, and the effective cross section, A , in square centimeters, of each leg is:

$$A = m/4l\delta \quad (2)$$

where:

- m = total mass of specimen strips, g;
- l = length of specimen strips, cm (usually 28 or 30.5 cm); and
- δ = standard assumed density of specimen material (see Practice A 34/A 34M), g/cm³.

8.2 Core Loss—To obtain the specific core loss of the specimen in watts per unit mass, it is necessary to subtract all secondary circuit power included in the wattmeter indication before dividing by the active mass of the specimen, so that for a specific magnetic flux density and frequency the specific core loss in watts per pound is as follows:

$$P_{c(B,f)} = 453.6 (P_c - E_2^2/R)/m_1 \quad (3)$$

where:

- P_c = core loss indicated by the wattmeter, W;
- E_2 = rms value of secondary voltage, V;
- R = parallel resistance of wattmeter potential circuit and all other connected secondary loads, Ω ; and
- m_1 = active mass, g.

In the 25-cm Epstein frame, it is assumed that 94 cm is the effective magnetic path with specimen strips 28 cm or longer. For the purpose of computing core loss, the active mass of the specimen (less than the total mass) is assumed to be as follows:

$$m_1 = l_1 m / (4l) = 94m / 4l = 23.5m/l \quad (4)$$

where:

- m = total specimen mass in pounds;
- l_1 = effective magnetic path length, cm; and
- l = actual strip length, cm.

8.3 Form Factor Correction—The percent error in form factor is given by the following equation:

$$F = 100(E_2 - E_f)/E_f \quad (5)$$

assuming (Note 4) that:

$$\text{observed } P_{c(B,f)} = [(\text{corrected } P_{c(B,f)})/100]h + (\text{corrected } P_{c(B,f)})Ke/100,$$

then, the corrected core loss, which shall be computed when F is greater (Note 5) than $\pm 1\%$, is:

$$\text{Corrected } P_{c(B,f)} = (\text{observed } P_{c(B,f)})100/(h + Ke) \quad (6)$$

where:

- $\text{observed } P_{c(B,f)}$ = specific core loss calculated by the equations in 8.2,
- h = percentage hysteresis loss at magnetic flux density B ,
- e = percentage eddy-current loss at magnetic flux density B , and
- K = $(E_2/E_f)^2$.

Obviously, $h = 100 - e$ if residual losses are considered negligible. The values of h and e in the above equation are not critical when waveform distortion is low. Typical values at 50 or 60 Hz for the common classes of materials, strip thicknesses, and specimen form are shown in Table 1. Values for materials other than those shown may be obtained using core loss separation methods and are a matter of agreement between the producer and the user.

TABLE 1 Eddy-Current Loss (Typical)

Material	Specimen	Assumed Eddy-Current Loss, percent (at 50 or 60 Hz), for Strip Thicknesses in in. [mm]						
		0.007 [0.18]	0.009 [0.23]	0.011 [0.27]	0.012 [0.30]	0.014 [0.35]	0.0190.025 [0.47][0.64]	20 30 40
Nonoriented materials ^A	half and half	20	30	40
Nonoriented materials ^A	parallel	25	35	45
Oriented materials ^B	parallel	35	45	50	50	55

^A These eddy-current percentages were developed for and are appropriate for use with nonoriented silicon steels as described in Specifications A 677/A 677M and A 683/A 683M where (%Si + 1.7 × %Al) is in the range 1.40 to 3.70.

^B These eddy-current percentages were developed for and are appropriate for use with oriented silicon steels as described in Specification A 876/A 876M.

NOTE 4—In determining the form factor error, it is assumed that the hysteresis component of core loss will be independent of the form factor if the maximum value of magnetic flux density is at the correct value (as it will be if a flux voltmeter is used to establish the value of the magnetic flux density) but that the eddy-current component of core loss, being a function of the rms value of the voltage, will be in error for nonsinusoidal voltages. While it is strictly true that frequency or form factor separations do not yield true values for the hysteresis and eddy-current components, yet they do separate the core loss into two components, one which is assumed to vary as the second power of the form factor and the other which is assumed to be unaffected by form factor variations. Regardless of the academic difficulties associated with characterizing these components as hysteresis and eddy-current loss, it is observed that the equation for correcting core loss for waveform distortion of voltage based on the percentages of first-power and second-power of frequency components of core loss does accomplish the desired correction under all practical conditions if the form factor is accurately determined and the distortion not excessive.

NOTE 5—It is recommended that tests made under conditions where the percent error in form factor, *F*, is greater than 10 % be considered as likely to be in error by an excessive amount, and that such conditions be avoided.

8.4 *Exciting Current*—The rms exciting current is often normalized for circuit parameters by converting to the following forms:

$$\text{rms exciting force, } N_1 I / l_1 = N_1 I / 94 \text{ A-turns/cm (Note 6)}$$

$$\text{or ac magnetic field strength, } H_z = 0.4\pi \sqrt{2} N_1 I / l_1 \text{ Oe}$$

where:

- N_1 = number of turns in primary winding;
- I = rms value of exciting current, A; and
- H_z = ac magnetic field strength, Oe.

NOTE 6—In previous issues of Test Method A 343, the path length for permeability and exciting current has been taken as 88 cm. In the 1960 and subsequent revisions, the path length has been 94 cm to be consistent with core-loss determination.

The specific exciting power in rms volt-amperes per pound is:

$$P_{z(B,f)} = 453.6 E_2 I / m_1 \tag{7}$$

where:

- E_2 = rms value of secondary voltage, V;
- I = rms value of exciting current, A; and
- m_1 = active mass, g.

8.5 *Permeability:*

8.5.1 For various types of applications, certain types of ac permeability data are more useful than others.

8.5.2 One type of ac permeability directly related to the rms exciting current (or rms excitation) or ac impedance is characterized by the symbol μ_z and is computed as follows (Note 7):

$$\mu_z = B_i / H_z \tag{8}$$

where:

- B_i = maximum intrinsic flux density, G, and
- H_z = ac magnetic field strength, Oe (Note 8).

NOTE 7—For simplification and convenience in the calculation of ac permeabilities the value of B_i is used to replace B_m in the permeability equation. This entails no loss of accuracy until the magnetic field strength H_p becomes appreciable in magnitude when compared to the value of B_i . If greater accuracy is essential B_m or $(B_i + H_p)$ should be used to replace the B_i in these equations.

NOTE 8— H_z is computed from the rms value of the complex exciting current by assuming a crest factor of $\sqrt{2}$. Thus it is based on a sinusoidal current having a rms value equal to the rms value of the complex current.

8.5.3 For control work in the production of magnetic materials, it is often desirable to determine an ac permeability value that is more directly comparable to the dc permeability value for the specimen. This is accomplished by evaluating H_p from the measured peak value of the exciting current at some value of H_p sufficiently above the knee of the magnetization curve that the magnetizing component of the exciting current is appreciably greater than the core loss component. Such a test point for many commercial materials is an H_p value of 10 Oe (796 A/m). Permeability determined in this way is characterized by the symbol μ_p , and is computed as follows (Note 7):

$$\mu_p = B_i / H_p \tag{9}$$

where H_p is the peak exciting magnetic field strength evaluated from measurements of peak current made either with the permeability-inductor or peak-reading-voltmeter methods (see 6.7.1 and 6.7.2) and in accordance with the equations in 8.6.

8.6 *H_p from Peak Exciting Current*—The peak exciting current, I_p in amperes, may be measured using the air-core mutual inductor and flux voltmeter as follows:

$$I_p = E_{fm} / \sqrt{2\pi f L_m} \tag{10}$$

where:

- E_{fm} = flux voltage induced in secondary winding of mutual inductor, V;
- f = frequency, Hz; and
- L_m = mutual inductance, H.

The peak exciting current, I_p in amperes, may be computed from measurements using a standard resistor and a peak-reading voltmeter as follows:

$$I_p = E_{p-p} / 2R_1 \tag{11}$$

where:

- E_{p-p} = peak-to-peak voltage indicated by peak-reading voltmeter, V, and
- R_1 = resistance of standard resistor, Ω .

The peak magnetic field strength, H_p in oersteds, may be calculated as follows:

$$H_p = 0.4\pi N_1 I_p / l_1 \quad (12)$$

where:

N_1 = number of turns in primary winding;
 I_p = peak exciting current, A; and
 l_1 = effective magnetic path length, cm.

9. Calculations (SI Units)

9.1 Calculate the value of the flux voltage E_f at the desired test magnetic flux density in the specimen (when corrected for flux as a result of H in the material and in the air space encircled by the test winding through the use of the required air-flux compensator) in accordance with the following basic equation discussed in 1.3 of this test method.

$$E_f = \sqrt{2}\pi B_f A N_2 f \quad (13)$$

B_i = maximum intrinsic flux density, T;
 A = effective cross-sectional area of the test specimen, m²;
 N_2 = number of turns in secondary winding; and
 f = frequency, Hz.

9.1.1 In the case of Epstein specimens, where the total number of strips is divided into four equal groups comprising the magnetic circuit, the mass of the specimen in each of the four legs of the magnetic circuit becomes $m/4$, and the effective cross section, A , in square metres, of each leg is:

$$A = m/4l\delta \quad (14)$$

where:

m = total mass of specimen strips, kg;
 l = length of specimen strips, m (usually 0.28 or 0.305 m);
 and
 δ = standard assumed density of specimen material (see Practice A 34/A 34M), kg/m³.

9.2 *Core Loss*—To obtain the specific core loss of the specimen in watts per unit mass, it is necessary to subtract all secondary circuit power included in the wattmeter indication before dividing by the active mass of the specimen, so that for a specific magnetic flux density and frequency the specific core loss in watts per kilogram is as follows:

$$P_{c(B;f)} = (P_c - E_2^2/R)/m_1 \quad (15)$$

where:

P_c = core loss indicated by the wattmeter, W;
 E_2 = rms value of secondary voltage, V;
 R = parallel resistance of wattmeter potential circuit and all other connected secondary loads, Ω ; and
 m_1 = active mass, kg.

In the 25-cm Epstein frame it is assumed that 0.94 m is the effective magnetic path with specimen strips 0.28 m or longer. For the purpose of computing core loss the active mass of the specimen (less than the total mass) is assumed to be as follows:

$$\begin{aligned} m_1 &= l_1 m / 4l \\ &= 0.94m / 4l \\ &= 0.235m / l \end{aligned} \quad (16)$$

where:

m = the total specimen mass, kg;
 l = the actual strip length, m; and

l_1 = effective magnetic path length, m.

9.3 *Form Factor Correction*—See 8.3.

9.4 *Exciting Current*—The rms exciting current is often normalized for circuit parameters by converting to the following forms:

$$\text{rms exciting force, } N_1 I / l_1 = N_1 I / 0.94 \text{ A/m (Note 9)}$$

or

$$\text{rms ac magnetic field strength, } H_z = \sqrt{2} N_1 I / l_1 \text{ A/m}$$

where:

N_1 = number of turns in primary winding;
 I = rms value of exciting current, A; and
 H_z = apparent ac magnetic field strength, A/m.

NOTE 9—In previous issues of Test Method A 343, the path length for permeability and exciting current has been taken as 0.88 m. In the 1960 and subsequent revisions, the path length has been 0.94 m to be consistent with core-loss determination.

The specific exciting power in rms volt-amperes per kilogram is:

$$P_{z(B;f)} = E_2 I / m_1 \quad (17)$$

where:

E_2 = rms value of secondary voltage, V;
 I = rms value of exciting current, A; and
 m_1 = active mass, kg.

9.5 *Permeability*:

9.5.1 For various types of applications, certain types of ac permeability data (in H/m) are more useful than others.

9.5.2 One type of ac permeability directly related to the rms exciting current (or rms excitation) or ac impedance is characterized by the symbol μ_z and is computed as follows (Note 10):

$$\mu_z = B_i / H_z \quad (18)$$

where:

B_i = maximum intrinsic flux density, T, and
 H_z = ac magnetic field strength, A/m (Note 11).

NOTE 10—For simplification and convenience in the calculation of ac permeabilities the value of B_i is used to replace B_m in the permeability equation. This entails no loss of accuracy until $\Gamma_m H_p$ becomes appreciable in magnitude when compared to the value of B_i . If greater accuracy is essential, B_m or $(B_i + \Gamma_m H_p)$ should be used to replace B_i in these equations. The magnetic constant Γ_m is equal to $4\pi \times 10^{-7} H/m$.

NOTE 11— H_z is computed from the rms value of the complex exciting current by assuming a crest factor of $\sqrt{2}$. Thus it is based on a sinusoidal current having a rms value equal to the rms value of the complex current.

9.5.3 For control work in the production of magnetic materials, it is often desirable to determine an ac permeability value that is more directly comparable to the dc permeability of the specimen. This is accomplished by evaluating H_p from the measured peak value of the exciting current at some value of H_p sufficiently above the knee of the magnetization curve that the magnetizing component of the exciting current is appreciably greater than the core-loss component. Such a test point for many commercial materials is an H_p value of 796 A/m. Permeability determined in this way is characterized by the symbol μ_p and is computed as follows (Note 10):

$$\mu_p = B_i / H_p \quad (19)$$

where:

H_p = peak exciting magnetic field strength evaluated from measurements of peak current made either with the permeability inductor or peak-reading-voltmeter methods (see 6.7.1 and 6.7.2) and in accordance with the equations in 9.6.

9.6 H_p from Peak Exciting Current—The peak exciting current, I_p in amperes, may be measured using the air-core mutual inductor and flux voltmeter as follows:

$$I_p = E_{fm} / \sqrt{2\pi f L_m} \quad (20)$$

where:

E_{fm} = flux voltage induced in secondary winding of mutual inductor, V;

f = frequency, Hz; and

L_m = mutual inductance, H.

The peak exciting current, I_p in amperes, may be computed from measurements using a standard resistor and a peak-reading voltmeter as follows:

$$I_p = E_{p-p} / 2R_I \quad (21)$$

where:

E_{p-p} = peak-to-peak voltage indicated by peak-reading voltmeter, V, and

R_I = resistance of standard resistor, Ω .

The peak magnetic field strength, H_p in amperes per meter, may be calculated as follows:

$$H_p = N_I I_p / l_1 \quad (22)$$

where:

N_I = number of turns in primary winding;

I_p = peak exciting current, A; and

l_1 = effective magnetic path length, m.

10. Precision and Bias

10.1 *Interlaboratory Test Programs*—Two interlaboratory studies have been conducted. In the first study, three blended Epstein specimens each of ASTM Type 27G051 and ASTM Type 47S188 materials were circulated to 14 participating laboratories. In the second study, three blended Epstein specimens of ASTM Type 64D430 material were circulated to 23 participating laboratories. Practice E 691 was followed for the design of the experiment and the analysis of the data for both studies. The details of the studies are given in ASTM Research Report Nos. A06-1000 and A06-1002.⁶

10.2 *Test Result*—The precision information given below for core loss or permeability as a percentage of the measured value is for the comparison of two test results, each of which is a single measurement.

10.3 *Precision*—See Table 2.

TABLE 2 Repeatability and Reproducibility Limits for Specific Core Loss and Peak Permeability Measurements

NOTE 1—The terms repeatability and reproducibility are used as specified in Practice E 177. The respective standard deviations among test results may be obtained by dividing the above limit values by 2.8.

ASTM Type 27G051 Material			
	Specific Core Loss at 60 Hz and at Maximum Intrinsic Flux Density, $B_p =$		Relative Peak Permeability at Peak Magnetic Field Strength, $H_p =$
	15 kG [1.5 T]	17 kG [1.7 T]	10 Oe [796 A/m]
Average Test Value	0.481 W/lb [1.06 W/kg]	0.699 W/lb [1.54 W/kg]	1840
95 % repeatability limits ^A	0.6 %	0.7 %	0.12 %
95 % reproducibility limits ^B	3.4 %	3.1 %	0.62 %
ASTM Type 47S188 Material			
	Specific Core Loss at 60 Hz and at Maximum Intrinsic Flux Density, $B_p =$		Relative Peak Permeability at Peak Maximum Intrinsic Flux Density, $B_p =$
	10 kG [1.0 T]	15 kG [1.5 T]	15 kG [1.5 T]
Average Test Value	0.698 W/lb [1.54 W/kg]	1.67 W/lb [3.68 W/kg]	1909
95 % repeatability limits ^A	0.3 %	0.6 %	1.6 %
95 % reproducibility limits ^B	3.8 %	3.5 %	8.2 %
ASTM Type 64D430 Material			
	Specific Core Loss at 60 Hz and at Maximum Intrinsic Flux Density, $B_p =$		Relative Peak Permeability at Peak Maximum Intrinsic Flux Density, $B_p =$
	10 kG [1.0 T]	15 kG [1.5 T]	15 kG [1.5 T]
Average Test Value	1.57 W/lb [3.46 W/kg]	3.83 W/lb [8.44 W/kg]	2291
95 % repeatability limits ^A	0.2 %	0.3 %	1.1 %
95 % reproducibility limits ^B	3.5 %	2.0 %	6.2 %

^A 95 % repeatability limits (within laboratory).

^B 95 % reproducibility limits (between laboratories).

10.4 *Bias*—Since there is no accepted reference material, method, or laboratory suitable for measuring the magnetic properties determined using this test method, no statement of bias is being made.

11. Keywords

11.1 alternating-current; ammeter; core loss; customary units; Epstein; exciting power; magnetic; magnetic flux density; magnetic material; magnetic test; permeability; power frequency; voltmeter; wattmeter

⁶ Available from ASTM International Headquarters. Request RR: A06-1000 and RR: A06-1002.

ANNEXES**(Mandatory Information)****A1. DETAILS OF CONSTRUCTION FOR EPSTEIN TEST FRAMES AND OTHER COMPONENTS****A1.1 Epstein Test Frame**

A1.1.1 General principles involved in the construction of standard 25-cm Epstein test frames are given in 6.2 of this test method. Specific details of wire sizes, turns and dimensional data are given in Table A1.1 of this annex along with the approximate electrical characteristics to be expected.

A1.1.2 The standard air-flux compensator, described in a general way in 6.2.5, uses a tubular (or solid) winding form 2 in. [50.8 mm] in diameter by 1 in. [25.4 mm] in length and two end pieces (either square or round) about 4 to 4½ in. [102 to 114 mm] across and ¼ to ½ in. [6.4 to 12.7 mm] thick. The winding form and end pieces may be of any nonconducting, nonmagnetic material. Screws or bolts used for assembly shall be nonmagnetic. The secondary winding is layer wound over the primary and initially should be comprised of at least 10 % greater number of turns than indicated in Table A1.1 of this annex to provide for removal of turns to adjust the secondary to the exact number of turns that will completely cancel the mutual inductance of the solenoid windings. A layer of insulating material a few thousandths of an inch (0.001 in. = 0.0254 mm) thick shall be used between primary and secondary windings. The adjustment of the mutual inductor may be checked by passing an ac current of 2 to 5 A through the primary winding of the test frame with no specimen in the solenoids, but with the air-flux compensator connected in proper polarity, and observing the open-circuit ac voltage at the secondary terminals with a voltmeter. When this voltage is of

the order of 1 or 2 mV or less, the air-flux compensator may be assumed to be adequately compensated.

A1.2 Crest Ammeter Mutual Inductor

A1.2.1 The permeability mutual inductors, when constructed in accordance with Table A1.2 of this annex use tubular winding forms and end disks made from nonconducting, nonmagnetic material and layer wound primary and secondary windings. In this inductor the primary is split, with one half being wound directly on the winding form, followed by the full secondary winding, and finishing with the remaining half of the primary winding. A single thickness of fiber insulating material should be used between each layer of the secondary winding to facilitate winding and improve the frequency characteristics. The two halves of the primary shall be connected in series. The mutual inductance may be measured on a suitable bridge, or the calibration may be made to acceptable accuracy by passing sinusoidal currents at 60 Hz through the primary winding and reading the secondary voltage using the flux voltmeter which is to be calibrated to read E_{fm} in terms of crest amperes of exciting current. The mutual inductor must be so located that no appreciable externally produced leakage flux links the secondary winding in the absence of any primary current. If the secondary current is negligible at the time of measurement the voltmeter will indicate approximately 0.12π flux V/mH of mutual inductance/rms A sinusoidal primary current (or $0.06 \sqrt{2} \pi$ flux V/peak A of sinusoidal primary current/mH).

TABLE A1.1 Specifications for Standard Epstein Frames Having Replaceable Tube Liners

NOTE 1—All conductors are enameled copper wire and all turns are close-wound, except that the turns of single layer or incomplete layers shall be uniformly distributed.

Nominal ^A specimen weight, kg	2	1	0.5
Total turns	700	700	700
Approximate secondary voltage at 60 Hz and 15 kG (1.5T)	65	32.5	16.3
Dimension of forms:			
Inner form (liner)			
inside dimensions, in.	0.750 × 1.25	0.375 × 1.25	0.250 × 1.25
outside dimensions, in.	0.875 × 1.375	0.500 × 1.375	0.375 × 1.375
Winding form			
inside dimensions, in.	0.906 × 1.406	0.563 × 1.406	0.438 × 1.406
outside dimensions, in.	1.031 × 1.531	0.688 × 1.531	0.563 × 1.531
Solenoid windings:			
Primary (top) winding			
layers	3	3	3
AWG wire size	2 No. 15 (0.057 18 in.)	2 No. 15 (0.057 18 in.)	2 No. 15 (0.057 18 in.)
resistance, Ω	0.57	0.50	0.48
self inductance, mH	1.26	0.99	0.91
Secondary (bottom) winding			
layers	1	1	1
AWG wire size	No. 19 (0.0359 in.)	No. 19 (0.0359 in.)	No. 19 (0.0359 in.)
resistance, Ω	2.13	1.85	1.75
self inductance, mH	0.85	0.65	0.58
Air flux compensator:			
Dimension of winding form			
diameter, in.	2.0	2.0	2.0
length, in.	1.0	1.0	1.0
Primary (inner) winding			
layers	4	4	4
turns	44	44	44
AWG wire size	No. 13 (0.072 in.)	No. 13 (0.072 in.)	No. 13 (0.072 in.)
resistance, Ω	0.06	0.06	0.06
self inductance, mH	0.12	0.12	0.12
Secondary (outer) winding			
approximate turns	425	315	270
AWG wire size	No. 19 (0.0359 in.)	No. 19 (0.0359 in.)	No. 19 (0.0359 in.)
resistance, Ω	3.5	2.5	2.1
self inductance, mH	15.9	8.6	6.2
Approximate mutual inductance, mH	0.83	0.64	0.57
Solenoids and Compensator:			
Total resistance at primary terminals, Ω	0.63	0.56	0.54
Total inductance at primary terminals, mH	1.38	1.11	1.03
Total resistance at secondary terminals, Ω	5.63	4.30	3.82
Total inductance at secondary terminals, mH	16.8	9.3	6.8

^A Based on 28-cm-long Epstein strips.
25.4 mm = 1 in.

TABLE A1.2 Examples of Standard Crest Ammeter Mutual Inductors For Typical Crest Ammeter Use^A

Inductor ^B	1	2	3	4
Winding form: ^C				
Outside diameter, in. [mm]	4 [102]	4 [102]	4 [102]	3 [76]
Length, in. [mm]	4 5/8 [117]	1 5/8 [41]	2 [51]	2 [51]
End disk diameter, in. [mm]	8 1/4 [210]	7 1/2 [191]	9 [229]	9 [229]
Primary windings: ^D				
AWG wire size ^E	No. 8 sq	No. 6 sq	No. 9	No. 8
Layers	8	4	6	12
Turns ^F	240	32	96	156
Secondary Windings: ^B				
AWG wire size ^E	No. 28	No. 28	No. 22	No. 16
Layers	32	32	41	17
Turns	8640	3200	1540	546
Electrical characteristics:				
Primary self inductance, mH	5.01	0.14	1.7	2.35
Primary resistance, Ω	0.25	0.023	0.14	0.10
Secondary self inductance, mH	7350	1650	800	50.98
Secondary resistance, Ω	860	296	65	3.65
Mutual inductance, ^F mH	181.2	12.9	35.1	7.066

^A To maintain accuracy, the flux voltmeter should not draw any appreciable current that can change the mutual inductor secondary¹ Terminal¹ voltage (see 6.7.1).

^B In Inductors 1, 2, and 3, generally the primaries are divided into two sections by the secondary, that is, one-half the primary turns are placed on the form first; the complete secondary winding second, and the remaining one-half of the primary turns placed on top of the secondary. The top and bottom primary windings shall be connected in series.

^C The tubular winding form and the end disks shall be made of nonmagnetic, nonconducting material. Other parts of the winding form shall be nonmagnetic.

^D An insulating layer of paper should be placed between windings.

^E All conductors are at least enamel insulated.

^F It may be desirable to make the crest ammeter direct reading in peak oersteds or peak A/m. This inductor may be tapped for this purpose if desired.

A2. RECOMMENDED STANDARD TEST VALUES

A2.1 Standard Test Values

A2.1.1 For tests at 50 or 60 Hz on flat-rolled materials in standard thicknesses, the following test points are recommended:

A2.1.1.1 Test for core loss (and rms exciting current if required) at magnetic flux densities of 10, 15, or 17 kG [1.0, 1.5, or 1.7 T], and

A2.1.1.2 Tests for ac permeability from peak exciting current (if required) at a magnetic flux density of 15 kG [1.5 T] or at a magnetic field strength of 10 Oe [796 A/m].

A3. PREPARATION OF EPSTEIN TEST SPECIMENS

A3.1 Test Specimens

A3.1.1 When magnetic properties of the basic magnetic material are desired (with effects of specimen shape, joints in the magnetic circuit, and characteristics of the test windings reduced to negligible proportions), the test specimen shall, whenever possible, consist of strips (commonly called Epstein strips) arranged in an Epstein frame so as to constitute a square magnetic circuit with the strips completely overlapped (double lapped) at the corners. Flat-rolled magnetic materials supplied as sheets or coils preferably shall be tested in this specimen form whenever dimensions permit.

A3.1.2 The Epstein test specimens shall consist of strips cut from sheets or coils in accordance with Practice A 34/A 34M. The strips shall be 3.00 cm [1.181 in. or 30 mm] in width and not less than 28.0 cm [11.02 in. or 280 mm] in length. If, for ease of assembly and disassembly of the specimen in the test frame, it is desired to use strips slightly longer than 28.0 cm [280 mm], a length of 30.5 cm [12.01 in. or 305 mm] is recommended.

A3.1.3 The nominal mass of an Epstein test specimen shall be approximately 71.5, 36, or 18 g/cm [7.15, 3.6, 1.8 g/mm] of

strip length (2-, 1-, or 0.5-kg total mass in 28-cm [280-mm] strip length) as determined by the instrumentation and test frame dimensions (Note A3.1). In no case shall the specimen consist of less than 12 strips. Specimens weighing less than 15 g/cm [1.5 g/mm] of strip length shall consist of at least 20 strips. In all cases, the specimen is subject to the requirement that the strips be taken so as to adequately represent the areas being sampled, and that the total number of test strips be a multiple of four. Table A3.1 gives the number of strips frequently used to meet this requirement for various strip thicknesses.

NOTE A3.1—The dimensions of the winding form of the test frame should be suitable for accommodating the desired specimen mass without excessive unfilled space within the test windings. Standard test frames (see 6.2) are designed with dimensions accommodating nominal specimen weights of 2, 1, or 0.5 kg. Increased sensitivity of instruments will be necessary for adequate performance on specimens of smaller than nominal weight. Specimens weighing less than about one half the nominal mass for the test frame dimensions should not be used unless the instrumentation of the test equipment has been specifically designed for operation under such conditions.

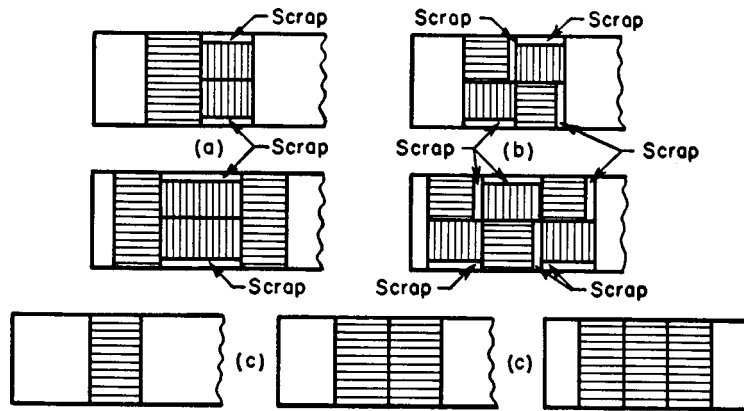

FIG. A3.1 Suggested Distribution of Strips to Be Cut from Sheets for Magnetic Tests

TABLE A3.1 Suggested Number of Test Strips

Strip Thickness, in. [mm]	Number of 280-mm Long Strips for Test Specimens of Nominal Mass		
	500 g	1000 g	2000 g
0.0310 [0.79]	12	20	40
0.0280 [0.71]	12	24	44
0.0250 [0.64]	12	24	48
0.0220 [0.56]	16	28	56
0.0185 [0.47]	16	32	64
0.0170 [0.43]	20	36	72
0.0155 [0.39]	20	40	80
0.0140 [0.36]	24	44	88
0.0125 [0.32]	24	48	96
0.0110 [0.28]	28	56	112
0.0090 [0.23]	36	68	136
0.0070 [0.18]	44	88	176

A3.1.4 If the specimen is to comprise strips with half the total number cut parallel or with the direction in which the

material has been rolled and half transverse or across the direction of rolling, it is recommended that sufficient strips be cut in accordance with the arrangement indicated in Fig. A3.1 (a) or (b). Where the material has been produced as continuous cold-reduced coils, sufficient length should be discarded from the end of the coil to insure uniform properties in the test strips.

A3.1.5 If the test specimen comprises only parallel or “with-grain” strips, it is recommended that sufficient strips be cut in accordance with Fig. A3.1 (c).

A3.1.6 When less than the total number of strips obtained from the sampled area are needed for the test specimen, the excess strips should be discarded equally from all locations in the sampled areas. For instance, if approximately one fourth of the total strips obtained is excess, every fourth strip should be discarded.

APPENDIXES

(Nonmandatory Information)

X1. BASIC PRINCIPLES AND DEVELOPMENT OF EPSTEIN TEST EQUATIONS

X1.1 Basic Principles

X1.1.1 The basic features involved in these alternating-current methods, which should be strictly adhered to by the user unless otherwise stated in the individual test methods, are as follows:

X1.1.2 The test specimen shall be of uniform cross section perpendicular to the direction of the flux path and should have uniform properties in any given direction.

X1.1.3 The flux waveform, as judged by the form factor of the voltage wave induced in an unloaded secondary winding, shall be sinusoidal within limits described in the individual test methods. To accomplish this, the power source must generate a closely sinusoidal waveform, and the primary circuit impedance (including the power source) shall be kept as low as possible.

X1.1.4 Voltage and frequency shall be very closely controlled within limits given in the individual test methods.

X1.1.5 Alternating-current normal induction, B , shall be determined (in accordance with X1.2 or X1.3) from measurements made with a voltmeter responsive to the full-wave average value of the voltage (rectifying-type voltmeter), commonly called a flux voltmeter,⁷ connected to an essentially unloaded secondary winding enclosing the specimen. The flux voltmeter shall conform to the specifications given in the individual test methods.

X1.1.6 The value of the effective test specimen cross-sectional area shall be determined from mass, length, and density of the test specimen wherever feasible (Practice A 34/A 34M). Equations for calculating this area are given in the individual test methods.

⁷ See, Camilli, G., “A Flux Voltmeter for Magnetic Tests,” *Journal*, American Institute of Electrical Engineers., JAIEE, Vol 45, October 1926, p. 721; also Smith, B. M., and Concordia, C., “Measuring Core Loss at High Densities,” *Electrical Engineering*, ELENA, Vol 51, No. 1, January 1932.

X1.1.7 Core-loss measurements shall be made by using circuitry, given in the individual test methods, which avoids the inclusion of the I^2R (conductor resistance loss) of the primary test winding. In the wattmeter method, this involves the use of a wattmeter connected so that the total exciting current of the specimen flows through the current coils of the instrument, and so that the induced voltage in the secondary winding of the test frame is applied to the potential coil circuit of the instrument. In the bridge method, it involves evaluation of the component of the exciting current which is in phase with the induced voltage (or the resistive component of that portion of the specimen's complex impedance that can be attributed to the core material). The core loss is the product of the "in-phase" current component and the induced voltage.

X1.1.8 Exciting-current measurements shall be made with an ammeter whose indications are proportional to the rms value of the current regardless of its waveform. The impedance of the ammeter must be low enough to avoid appreciable distorting effect on the flux waveform.

X1.1.9 Secondary-circuit power drain must be negligible, or its effects on the measured properties must be evaluated and corrected by calculation.

X1.1.10 Whenever tests are made under conditions in which the effects of accidental polarization of the specimen by handling in the earth's magnetic field, or previous magnetic history, may have a significant effect on the measured properties, demagnetization of the test specimen shall be used, as dictated by the individual test methods.

X1.1.11 Various types of ac permeability may be determined from measurements described in these methods. It should be understood that these ac permeabilities are in reality mathematical definitions each based on different specified assumptions. Therefore, their individual values may differ considerably from each other and from the normal dc permeability. See also Terminology A 340 for definitions.

X1.1.11.1 *Inductance Permeability*, μ_L —A type of ac permeability related to parallel inductance is calculated from the value of the reactive of the exciting current (or the reactive component of that portion of the specimen's complex impedance attributed to the core material) as measured in the varmeter method (see Test Method A 889/A 889M).

X1.1.11.2 *Impedance Permeability*, μ_z —A type of ac permeability calculated from the rms value of the exciting current. This requires the exciting-current harmonics to be treated as part of a sinusoidal current of fundamental frequency.

X1.1.11.3 *Peak Permeability*, μ_p —A type of ac permeability which is calculated from the measured peak value of the total exciting current. The effects of phase relationships and core loss components are ignored.

X1.2 Basic Equation for Flux Density (Customary Units)

X1.2.1 Where a magnetic circuit of uniform cross-sectional area, as in these methods, is subjected to symmetrical ac magnetization of uniform lengthwise distribution, and the cross section of that magnetic circuit is encircled by a conductor not carrying the exciting current, it can be shown that the measured average value of the full-wave rectified voltage induced in the winding is related to the maximum value of the flux density in the magnetic material by the equation:

$$E_{\text{avg}} = 4(B_i A + H_p A_w) N_2 / 10^{-8} \quad (\text{X1.1})$$

where:

- E_{avg} = average value of the fully rectified symmetrical voltage, V;
- B_i = peak value of the intrinsic flux density ($B - H_p$), G;
- A = solid cross section of the specimen, cm^2 ;
- H_p = peak value of the magnetic field strength, Oe;
- A_w = area enclosed by the secondary winding, cm^2 ;
- N_2 = number of turns in winding; and
- f = frequency, Hz.

Since the indications of the flux voltmeter are related to average volts by the equation:

$$E_f = \sqrt{2} \pi / 4 E_{\text{avg}} \quad (\text{X1.2})$$

where the factor $\sqrt{2} \pi / 4$ is the accepted value of the form factor of a sine wave, and since the air flux ($H_p A_w$) is kept negligibly small or by the use of an air flux compensating mutual inductor (see 6.2.5) the induced voltage after air flux correction as indicated on the flux voltmeter is:

$$E_f = \sqrt{2} \pi B_i A N_2 / 10^{-8} \quad (\text{X1.3})$$

This equation shall be used for relating the indications of the flux voltmeter, sometimes called flux volts, to the test magnetic flux density in these test methods. When the magnetic flux density is needed in terms of the normal induction B , or $B_i + H_p$, the value of H_p must be added when it is of significant magnitude. In a properly constructed Epstein frame the coefficient of coupling between its superimposed windings is so close to unity that each winding may be considered to have the same number of induced volts per turn.

X1.3 Basic Equation for Flux Density (SI Units)

X1.3.1 Where a magnetic circuit of uniform cross-sectional area, as in these methods, is subjected to symmetrical ac magnetization of uniform lengthwise distribution, and the cross section of that magnetic circuit is encircled by a conductor not carrying the exciting current, it can be shown that the measured average value of the full-wave rectified voltage induced in the winding is related to the maximum value of the flux density in the magnetic material by the equation:

$$E_{\text{avg}} = 4(B_i A + \Gamma_m H_p A_w) N_2 f \quad (\text{X1.4})$$

where:

- E_{avg} = average value of the fully rectified symmetrical voltage, V;
- B_i = peak value of the intrinsic flux density ($B - T_m H_p$), T;
- A = solid cross section of the specimen, m^2 ;
- H_p = peak value of the magnetic field strength, A/m;
- A_w = area enclosed by the secondary winding, m^2 ;
- N_2 = number of turns in winding; and
- f = frequency, Hz, and $\Gamma_m = 4\pi \times 10^{-7}$ H/m.

Since the indications of the flux voltmeter are related to average volts by the equation:

$$E_f = \sqrt{2} \pi / 4 E_{\text{avg}} \quad (\text{X1.5})$$

where the factor $\sqrt{2} \pi / 4$ is the accepted value of the form factor of a sine wave, and since the air flux ($\Gamma_m H_p A_w$) is kept negligibly small or by the use of an air flux compensating

mutual inductor (see 6.2.5), the induced voltage alter air flux correction as indicated on the flux voltmeter is:

$$E_f = \sqrt{2}\pi B_f AN_f f \quad (X1.6)$$

This equation shall be used for relating the indications of the flux voltmeter, sometimes called flux volts, to the test magnetic flux density in these test methods. When the magnetic flux

density is needed in terms of the normal induction B , or $B_i + \Gamma_m H_p$, the value of mH_p must be added when it is of significant magnitude. In a properly constructed Epstein frame, the coefficient of coupling between its superimposed windings is so close to unity that each winding may be considered to have the same number of induced volts per turn.

X2. RECOMMENDED STANDARD DATA FORMAT FOR COMPUTERIZATION OF MAGNETIC TEST DATA BASED ON TEST METHOD A343

X2.1 Because of the intense activity in building computerized materials databases and the desire to encourage their uniformity and therefore the ease of data comparison and data interchange, it is appropriate to provide recommended standard formats for the inclusion of specific types of test data in such databases. This also has the important effect of encouraging the builders of databases to include sufficiently complete information that comparisons among individual sources may be made with assurance that the similarities and/or differences in the test procedures and conditions are covered therein.

X2.2 Table X2.1 is a recommended standard format for the computerization of power frequency (25–400 Hz) magnetic test data as generated using the 25-cm Epstein test frame by Test Method A 343. Also see Table X2.2, Table X2.3, and Table X2.4 for additional information. There are three columns of information:

X2.2.1 *Field Number*—a reference number for ease of dealing with the individual fields within this format guideline. It has no permanent value and does not become part of the database itself.

X2.2.2 *Field Name and Description*—the complete name of the field, descriptive of the element of information that would be included in this field of the database.

X2.2.3 *Category Sets, Values, or Units*—a listing of the types of information that would be included in the field or in the case of properties or other numeric fields, the units in which the numbers are expressed. Category sets are closed (that is, complete) sets containing all possible (or acceptable) inputs to the field. Values are representative sets, listing sample (but not necessarily all acceptable) inputs to the field.

X2.3 The fields or elements of information included in this format are those recommended to provide sufficiently complete information that users may be confident of their ability to compare sets of data from individual databases and to make the database useful to a relatively broad range of users.

X2.4 It is recognized that many databases are prepared for very specific applications, and individual database builders may elect to omit certain pieces of information considered to be of no value for that specific application. However, there are a certain minimum number of fields considered essential to any database, without which the user will not have sufficient information to reasonably interpret the data. In the recommended standard format, these fields are marked with asterisks.

X2.5 The presentation of this format does not represent a

TABLE X2.1 Recommended Standard Data Format for Computerization of Magnetic Test Data per Test Method A 343 (Epstein Test Method)

Field No. ^A	Field Name and Description	Category Sets, Values, or Units
Test and Materials Identification		
1.*	Material identification	(This information will be supplemented
2.*	Lot identification	by material descriptions
3.*	Data source identification	based on Guide E 1338.)
4.*	Type of test	Epstein test
5.*	ASTM, ISO, or other applicable standard method number	A 343
6.	Date of applicable standard	year (for example 1986)
Specimen Information		
7.	Specimen identification	alphanumeric string
8.	Specimen number	alphanumeric string
9.	Specimen type	Epstein strips
10.*	Specimen thickness	in. (mm)
11.*	Specimen condition	see Table X2.2
12.*	Specimen orientation	see Table X2.3
13.*	Specimen mass	g (kg)
14.*	Specimen length	cm (m)
15.*	Assumed density	g/cm ³ (kg/m ³)
16.	Assumed % eddy current loss	percentage
17.	Assumed % eddy current loss	percentage
Test Results		
18.	Core loss	W/lb (W/kg)
19.	RMS exciting current	A
20.	Peak exciting current	A
21.	Specific exciting power	VA/lb (VA/kg)
22.	Impedance permeability	dimensionless
23.	Relative peak permeability	dimensionless
24.	Form factor	dimensionless
Test Parameters ^B		
25.*	Test temperature	°C
26.*	Test frequency	Hertz
27.*	Test magnetic flux density	Gauss (T)
28.*	Test magnetic field strength	Oe (A/m)
29.*	Form factor correction used	yes or no
30.*	Peak current measurement device	see Table X2.4
31.*	Primary turns	dimensionless
32.*	Comments	

^A* Denotes essential information for computerization of test results.

Field numbers are for reference only. They do not imply a necessity to include all these fields in any specific database nor imply a requirement that fields used be in this particular order.

^B It is customary to determine core loss at specified test magnetic flux density and to determine permeability at specified magnetic field strength.

requirement that all of the elements of information included in the recommendation must be included in every database. Rather it is a guide as to those elements that are likely to be useful to at least some users of most databases. It is understood that not all of the elements of information recommended for

TABLE X2.2 Category Set for Specimen Condition

As sheared Annealed after shearing

TABLE X2.3 Category Set for Specimen Orientation

Parallel to rolling direction Transverse to rolling direction Half parallel-half transverse Other
--

TABLE X2.4 Category Set for Peak Current Measurement Device

Mutual inductor method Peak reading ammeter
--

inclusion will be available for all databases; that fact should not discourage database builders and users from proceeding so long as the minimum basic information is included (the items

noted by the asterisks).

X2.6 This document has no implication on data required for materials production or purchase. Reporting of actual test results shall be as described in the actual material specification or as agreed to by the purchaser and manufacturer as shown on the purchase order and acknowledgment.

X2.7 Also, it is recognized that in some individual cases, additional elements of information of value to users of a database may be available. In those cases, databases builders are encouraged to include them as well as the elements in the recommended format.

X2.8 This format is only for magnetic test data generated by Test Method A 343. It does not include the recommended material description or the presentation of other specific types of magnetic test data. These items are covered by separate formats to be referenced in material specifications or other test standards.

ASTM International takes no position respecting the validity of any patent rights asserted in connection with any item mentioned in this standard. Users of this standard are expressly advised that determination of the validity of any such patent rights, and the risk of infringement of such rights, are entirely their own responsibility.

This standard is subject to revision at any time by the responsible technical committee and must be reviewed every five years and if not revised, either reapproved or withdrawn. Your comments are invited either for revision of this standard or for additional standards and should be addressed to ASTM International Headquarters. Your comments will receive careful consideration at a meeting of the responsible technical committee, which you may attend. If you feel that your comments have not received a fair hearing you should make your views known to the ASTM Committee on Standards, at the address shown below.

This standard is copyrighted by ASTM International, 100 Barr Harbor Drive, PO Box C700, West Conshohocken, PA 19428-2959, United States. Individual reprints (single or multiple copies) of this standard may be obtained by contacting ASTM at the above address or at 610-832-9585 (phone), 610-832-9555 (fax), or service@astm.org (e-mail); or through the ASTM website (www.astm.org).