



Standard Test Method for Magnetic Properties of High-Coercivity Permanent Magnet Materials Using Hysteresigraphs¹

This standard is issued under the fixed designation A 977/A 977M; the number immediately following the designation indicates the year of original adoption or, in the case of revision, the year of last revision. A number in parentheses indicates the year of last reapproval. A superscript epsilon (ϵ) indicates an editorial change since the last revision or reapproval.

1. Scope

1.1 This test method describes how to determine the magnetic characteristics of magnetically hard materials (permanent magnets), particularly their initial magnetization, demagnetization, and recoil curves and such quantities as the residual induction, coercive fields, knee field, energy products, and recoil permeability. This test method is suitable for all materials processed into bulk magnets by any common fabrication technique (casting, sintering, rolling, molding, and so forth), but not for thin films or for magnets that are very small or of unusual shape. Uniformity of composition, structure, and properties throughout the magnet volume is necessary to obtain repeatable results. Particular attention is paid to the problems posed by modern materials combining very high coercivity with high saturation induction, such as the rare-earth magnets, for which older test methods (see Test Method A 341) are unsuitable. An applicable international standard is IEC Publication 404-5.

1.2 The magnetic system (circuit) in a device or machine generally comprises flux-conducting and nonmagnetic structural members with air gaps in addition to the permanent magnet. The system behavior depends on properties and geometry of all these components and on the temperature. The tests described here measure only the properties of the permanent magnet material. The basic test method incorporates the magnetic specimen in a magnetic circuit with a closed flux path. Test methods using ring samples or frames composed entirely of the magnetic material to be characterized, as commonly used for magnetically soft materials, are not applicable to permanent magnets.

1.3 This test method shall be used in conjunction with Practice A 34/A 34M.

1.4 The values and equations stated in customary (cgs-emu or inch-pound) or SI units are to be regarded separately as standard. Within this test method, SI units are shown in brackets except for the sections concerning calculations where

there are separate sections for the respective unit systems. The values stated in each system may not be exact equivalents; therefore, each system shall be used independently of the other. Combining values from the two systems may result in nonconformance with this test method.

1.5 The names and symbols of magnetic quantities used in this test method, summarized in Table 1, are those currently preferred by U.S. industry.

1.6 This test method is useful for magnet materials having H_{ci} values between about 100 Oe and 35 kOe [8 kA/m and 2.8 MA/m], and B_r values in the approximate range from 500 G to 20 kG [50 mT to 2 T]. High-coercivity rare-earth magnet test specimens may require much higher magnetizing fields than iron-core electromagnets can produce. Such samples must be premagnetized externally and transferred into the measuring yoke. Typical values of the magnetizing fields, H_{mag} , required for saturating magnet materials are shown in Table 1.

1.7 *This standard does not purport to address all of the safety concerns, if any, associated with its use. It is the responsibility of the user of this standard to establish appropriate safety and health practices and determine the applicability of regulatory limitations prior to use.*

2. Referenced Documents

2.1 ASTM Standards:

A 34/A 34M Practice for Procurement Testing and Sampling of Magnetic Materials²

A 340 Terminology of Symbols and Definitions Relating to Magnetic Testing²

A 341/A 341M Test Method for Direct Current Magnetic Properties Using dc Permeameters and the Ballistic Test Methods²

E 177 Practice for Use of the Terms Precision and Bias in ASTM Test Methods³

2.2 *Magnetic Materials Procedure Association Standard:*
MMPA No. 0100-96 Standard Specifications for Permanent Magnet Materials⁴

¹ This test method is under the jurisdiction of ASTM Committee A06 on Magnetic Properties and is the direct responsibility of Subcommittee A06.01 on Test Methods.

Current edition approved Oct. 10, 2002. Published November 2002. Originally published as A 977 – 97. Last previous edition A 977 – 97.

² *Annual Book of ASTM Standards*, Vol 03.04.

³ *Annual Book of ASTM Standards*, Vol 14.02.

⁴ Available from Magnetic Materials Producers Association, 8 S. Michigan Ave., Suite 1000, Chicago, IL 60603.

TABLE 1 Symbols, Quantities, and Units

NOTE 1—IEC nomenclature calls B_r “remanence,” when B_r represents the B at $H = 0$ of the outermost hysteresis loop, and it calls B_r “remanent magnetic induction” for B at $H = 0$ at smaller loops.

Symbol	Quantity	SI Unit	Customary cgs-emu
A_t	Cross section of search coil	[m ²]	cm ²
B_d	Magnetic induction at BH_{\max}	[T]	G
B_{rec}	Magnetic induction at low point of recoil loop	[T]	G
B_r	Magnetic induction at remanence	[T]	G
d_1	Diameter of pole piece	[m]	cm
d_2	Diameter of homogeneous field	[m]	cm
H_d	Magnetic field strength at BH_{\max}	[A/m]	Oe
H_p	Magnetic field strength at low point of recoil loop	[A/m]	Oe
l	Distance between pole faces	[m]	cm
l_r	Length of test sample	[m]	cm
N	Number of turns of test coil		
e	Voltage induced in test coil	V	V
d	Total air gap between test sample and pole faces	[m]	cm
μ_0	A constant with value $\mu_0 = 4\pi \cdot 10^{-7}$ H/m		
μ_{rec}	Recoil permeability		

2.3 *International Electrotechnical Commission Document: Publication 404-5 Magnetic Materials – Part 5: Permanent Magnet (Magnetically Hard) Materials – Methods of Measurement of Magnetic Properties*⁵

3. Terminology

3.1 Basic magnetic units are defined in Terminology A 340 and MMPA Standard No. 0100–96. Additional definitions with symbols and units are given in Table 1 and Figs. 1-3 of this test method.

4. Significance and Use

4.1 This test method is suitable for magnet specification, acceptance, service evaluation, quality control in magnet production, research and development, and design.

4.2 When a test specimen is cut or fabricated from a larger magnet, the magnetic properties measured on it are not necessarily exactly those of the original sample, even if the material is in the same condition. In such instances, the test results must be viewed in context of part performance history.

4.3 Tests performed in general conformity to this test method and even on the same specimen, but using different test systems, may not yield identical results. The main source of discrepancies are variations between the different test systems in the geometry of the region surrounding the sample, such as, size and shape of the electromagnet pole caps (see Annex A1 and Appendix X1), air gaps at the specimen end faces, and especially the size and location of the measuring devices for H and B or for their corresponding flux values (Hall-effect probes, inductive sensing coils). Also important is the method

of B calibration, for example, a volt-second calibration of the fluxmeter alone versus an overall system calibration using a physical reference sample. The method of B and H sensing should be indicated in test reports (see Section 9).

5. Measuring Methods and Apparatus

5.1 Measuring Flux and Induction (Flux Density):

5.1.1 In the preferred B -measuring method, the total flux is measured with a sensing coil (search coil) that surrounds the test specimen and is wound as closely as possible to the specimen surface. Its winding length should be no more than a third of the specimen length, preferably less than one fifth, and must be centered on the specimen. The leads shall be twisted tightly. As the flux changes in response to sweeping the applied field, H , the total flux is measured by taking the time integral of the voltage induced in this coil. This measurement is taken with a fluxmeter. Modern hysteresigraphs use electronic integrating fluxmeters that allow convenient continuous integration and direct graphic recording of magnetization curves. If the signal is large enough, high-speed voltage sampling at the coil and digital integration is also possible.

5.1.2 The magnetic induction, B , is determined by dividing the total flux by the area-turns product, NA , of the B -sensing coil. For permanent magnets in general, and especially for high-coercivity materials, an air-flux correction is required (see 5.3 and 5.4).

5.1.3 The total error of measuring B shall be not greater than $\pm 2\%$.

5.1.4 The change of magnetic induction, $\Delta B = B_2 - B_1$, in the time interval between the times t_1 and t_2 is given as follows:

$$\Delta B = (10^8/AN) \int_{t_1}^{t_2} e \, dt \text{ (customary units)} \quad (1)$$

$$\Delta B = (1/AN) \int_{t_1}^{t_2} e \, dt \text{ (SI units)} \quad (2)$$

where:

- B = magnetic induction, G [T];
- A = cross-sectional area of the test specimen, cm² [m²];
- N = number of turns on the B -sensing coil;
- e = voltage induced in the coil, V;
- t = time, s; and
- $\int_{t_1}^{t_2} e \, dt$ = voltage integral = flux, V-s [Weber].

5.1.5 The change in the magnetic induction shall be corrected to take into account the air flux outside the test specimen that is linked by the sensing coil. The corrected change, B_{corr} , is given as follows:

$$\Delta B_{\text{corr}} = (10^8/AN) \int_{t_1}^{t_2} e \, dt - \Delta H (A_t - A) / A \text{ (customary units)} \quad (3)$$

$$\Delta B_{\text{corr}} = (1/AN) \int_{t_1}^{t_2} e \, dt - \mu_0 \Delta H (A_t - A) / A \text{ (SI units)} \quad (4)$$

where:

- A = average cross-sectional area of the sensing coil, cm² [m²];
- ΔH = change in field from t_1 until t_2 , Oe [A/m]; and
- μ_0 = magnetic constant [$4\pi \cdot 10^{-7}$ H/m].

5.2 Determining Intrinsic Induction:

⁵ Available from International Electrotechnical Commission (IEC), 3 rue de Varembe, P.O. Box 131, CH-1211, Geneva 20, Switzerland.

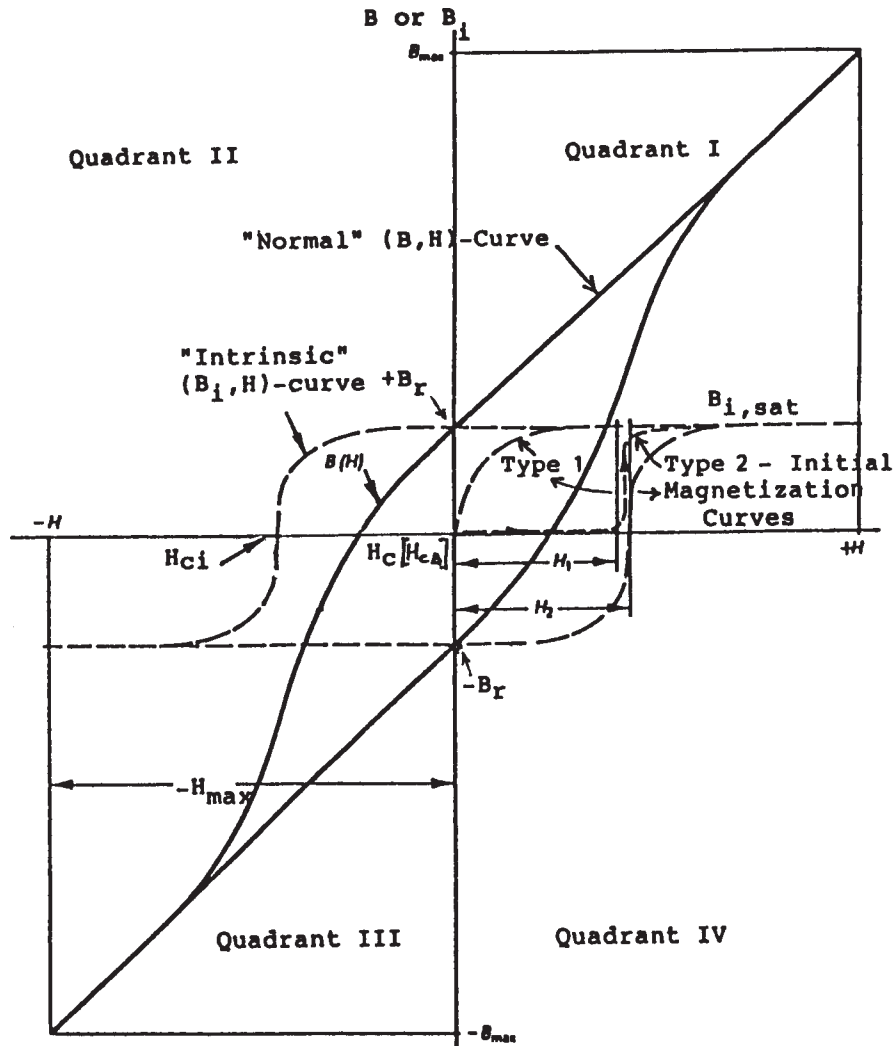

FIG. 1 Normal and Intrinsic Hysteresis Loops and Initial Magnetization Curves for Permanent Magnet Materials Illustrating Two Extremes of Virgin Sample Behavior

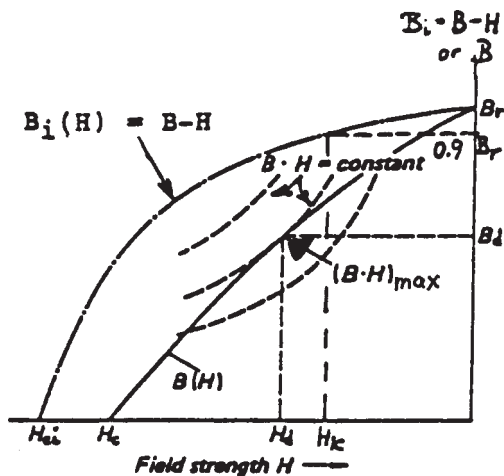

FIG. 2 Normal and Intrinsic Demagnetization Curves with Symbols for Special Points of Interest and Definition of Salient Properties. Illustration of Maximum Energy Product, Coercive Fields, and Definition of Knee Field

5.2.1 For high-coercivity magnets, it is more convenient to sense directly an electrical signal proportional to the intrinsic induction, derive the average B_i by dividing this flux by the area-turns product of the surrounding B coil, and to plot B_i versus H as the primary demagnetization curve. B then is obtained by mathematical or electronic addition of H to B .

5.2.2 The change of intrinsic induction in the test specimen can be determined by integrating the voltage induced in a device comprising two sensing coils, both subject to the same applied field H , where the test specimen is contained in only one of the coils (Coil 1). If each individual coil has the same area-turns product, and if the windings are connected electrically in opposition, the signal induced by the flux linking Coil 2 (not containing the specimen) will compensate for the output of Coil 1 except for B_i within the test specimen. The change of intrinsic induction in the specimen then is given as follows:

$$\Delta B_i = (10^8/AN) \int_{t_1}^{t_2} e \, dt \quad (\text{customary units}) \quad (5)$$

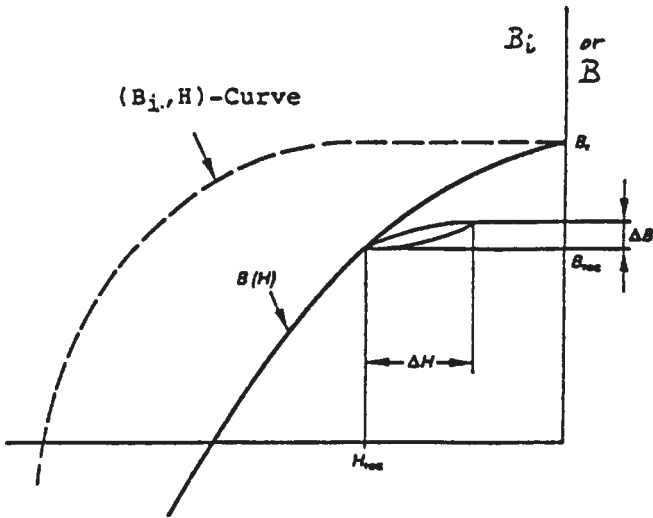

FIG. 3 Normal and Intrinsic Demagnetization Curves with Symbols for Special Points of Interest and Definition of Salient Properties. Illustration of Recoil Loop. Recoil Permeability is Defined as $\mu_{rec} \Delta B / \Delta H$

$$\Delta B_i = (1/AN) \int_{t_1}^{t_2} e dt \quad (\text{SI units}) \quad (6)$$

where:

- B_i = intrinsic induction, G [T];
- A = cross section of the test specimen, cm^2 [m^2]; and
- N = number of turns on Coil 1 containing the test specimen.

5.2.3 The two-sensing-coil device shall lie totally within the homogeneous field defined by Eq A1.1 and Eq A1.2. Test specimens of lower-coercivity magnets having a range of cross-sectional areas and shapes can then be measured with the same coil device. An arrangement of side-by-side coils of equal size is useful. Serious errors, however, are incurred when measuring B_i this way on high- B_r or high/coercivity magnets, or both, at applied fields of about 10 kOe or more. The errors are most severe for test specimens of short pole-to-pole length. Local pole-piece saturation causes strong field inhomogeneities. The specimen then must fill the cross section of Coil 1, and Coil 2 must be a thin and flat coil, or a coaxial annular coil, either centered on the specimen or in close proximity to its surface (see 5.3).

5.2.4 The total error of measuring B_i shall be not greater than $\pm 2\%$.

5.3 Measuring the Magnetic Field Strength:

5.3.1 For correct magnetization curves, one should know the magnetic field strength, H , inside the test specimen, averaged over the specimen volume if H is not uniform. But this inner field cannot be measured. At the surface of the test specimen, H is equal to the local field strength just inside the specimen in those locations (and only there) where the H vector is parallel to the side surface of the specimen. Therefore, a magnetic field strength sensor of small dimensions relative to the specimen is placed near the specimen surface and symmetrical with respect to the end faces, covering the shortest possible center portion of the specimen length. It shall be so oriented that it correctly measures the tangential field component.

5.3.2 To determine the magnetic field strength, a flat surface coil, a tightly fitted annular coil, a magnetic potentiometer, or a Hall probe is used together with suitable instruments. The dimensions of the magnetic field sensor and its location shall be such that it is within an area of limited diameter around the test specimen (see Annex A1).

5.3.3 The provisions of 5.3.2 are adequate for measurements on magnets having low-to-moderate intrinsic coercivity, such as Alnico and bonded ferrites. For high-coercivity, dense ferrites and especially for most rare earth-transition metal materials, it is essential for accurate measurement to use thin flat or radially thin annular H -sensing coils of short length ($< 1/5$ to $1/3$ of the specimen length), centered on the specimen and placed as close as possible to the specimen surface.

5.3.4 The same considerations apply to the H -flux compensation coil used in B_i measurements (see 5.2.3.) When pole saturation can occur, Coil 2 also shall be a thin conforming flat surface coil for rectangular specimen shapes or a thin annular coil closely surrounding a cylindrical specimen, and the specimen essentially shall fill the open cross-sectional area of the B -sensing Coil 1.

5.3.5 To reduce other measurement errors, the air gaps between the flat ends of the test specimen and the pole pieces shall be kept small, typically in the range 0.001 to 0.002 in. [0.025 to 0.050 mm] (see Fig. 4).

5.3.6 The magnetic field strength measuring system shall be calibrated. Any temperature dependence of the measuring instruments, (for example, Hall probes), must be taken into account. The total error of measuring H shall be not greater than $\pm 2\%$.

NOTE 1—The end faces of the test specimen should be in intimate contact with the pole faces. There are always unavoidable small air gaps as a result of surface roughness, poor parallelism of sample or pole faces, or intentional shimming to protect delicate specimens from deformation or crushing. These cause additional errors in the magnetic field strength measurement and indirectly in the B_i measurements through air flux compensation errors, even in the low H region. The maximum error in the field strength measurement, as a result of two symmetric gaps of length d (see Fig. 3) is approximately:

$$\Delta H/H = 2 B d / l_r H \quad (\text{customary units}) \quad (7)$$

$$\Delta H/H = 2 B d / \mu_0 l_r H \quad (\text{SI units}) \quad (8)$$

To keep the error $100 \Delta H/H < 1\%$ in the region of the $(BH)_{max}$ point, the gap thickness should be kept below the following values:

$$d = 0.00025 l_r \quad \text{for Alnico magnets,}$$

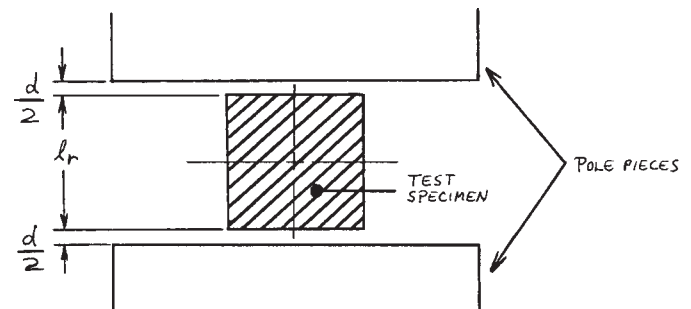

FIG. 4 Illustration Regarding the Influence of Air Gaps at the End Faces of the Test Specimen

$d = 0.005 l_r$, for hard ferrite magnets, and
 $d = 0.003 l_r$, for rare-earth magnets.

5.4 Plotting Magnetization and Demagnetization Curves:

5.4.1 Plotting of B_i , H curves or B , H curves is accomplished by combining one of the methods for magnetic field strength measurement from 5.3 with a B_i -measuring method from 5.2 or a B -measuring method from 5.1. A schematic for a typical hysteresigraph system is shown in Fig. 5.

5.4.2 Continuous Plotting of Magnetization Curves—Modern electronic integrators used in conjunction with inductive sensors for B_i or B , and in some instruments also for H , allow the continuous recording of magnetization, demagnetization, or recoil curves. A wide range of field sweep rates is possible. In the simplest but least desirable case, the exciting current of the electromagnet may be varied linearly, or the field sweep rate may be held constant. Even better it may be controlled with feedback from the measuring circuit for the (intrinsic) induction so as to achieve an approximately constant rate of change of B_i or B . Flexible sweep control requires a power supply for the electromagnet that can be programmed by an analog or digital electronic signal. For greatest flexibility, the power supply should be bipolar. Typical total recording times for a full hysteresis loop are between about 30 s and 5 min. Integrator drift errors can be kept acceptably small with reasonable operator care. The output voltages of the integrators and a Hall-effect field meter, if used, can be plotted directly with an analog x,y recorder, and salient property values are determined from this plot. Alternatively, the output voltages can be digitized, stored, and processed in a computer. Curves and calculated numerical values are then displayed on a monitor and printed out with a plotter or printer.

6. Calibration

6.1 The subsystems of the hysteresigraph for measuring field and flux quantities must be calibrated from time to time. Several alternative techniques are in common use. All ensure comparable degrees of reproducibility, but they yield strongly different absolute accuracy. The circuits for measuring flux

(induction or intrinsic induction) and the magnetizing field are usually calibrated independently. However, checking hysteresigraphs against each other by remeasuring demagnetization curves of reference magnets may link these two necessary calibrations.

6.2 Magnetic Flux and Induction:

6.2.1 Electronic fluxmeters are conveniently calibrated by using one of the following four methods. An accuracy of $\pm 0.1\%$ is achievable by the methods listed in 6.2.1.1-6.2.1.3. An error of $\pm 5\%$ must be expected from the method given in 6.2.1.4. All these methods, however, calibrate only the electronic integrating and indicating/recording instrument. They leave out the hysteresigraph's sensing coils, which introduce errors because of their location relative to test specimen and electromagnet pole caps, and whose area-turns product can change as the coils age or are abused. The specimen geometry itself also affects the B_i calibration. Experience has shown discrepancies of 5 to 10% between B_i measurements on different hysteresigraphs calibrated with volt-second standards. The four fluxmeter calibration methods are:

6.2.1.1 Use of a volt-second generator, consisting of a very stable source of a well-measured dc voltage and a precision timer. The level of this voltage and the length of time it is applied should be comparable to typical levels during a magnetic loop measurement with the hysteresigraph.

6.2.1.2 Use of a mutual inductance standard, by switching on and off a primary current measured with a precision ampere-meter. A known flux change is induced in the secondary winding of the standard, which serves as the V-s calibration signal in the fluxmeter circuit.

6.2.1.3 Use of a search coil of precisely known area-turns, that is moved into or removed from region of a time-constant homogeneous field, which has been measured with a nuclear magnetic resonance (NMR) gaussmeter. A rigidly constructed magnetic circuit comprising a highly stable permanent magnet with large iron pole pieces and a short air gap is a suitable field source for this. If it is well stabilized and shielded from

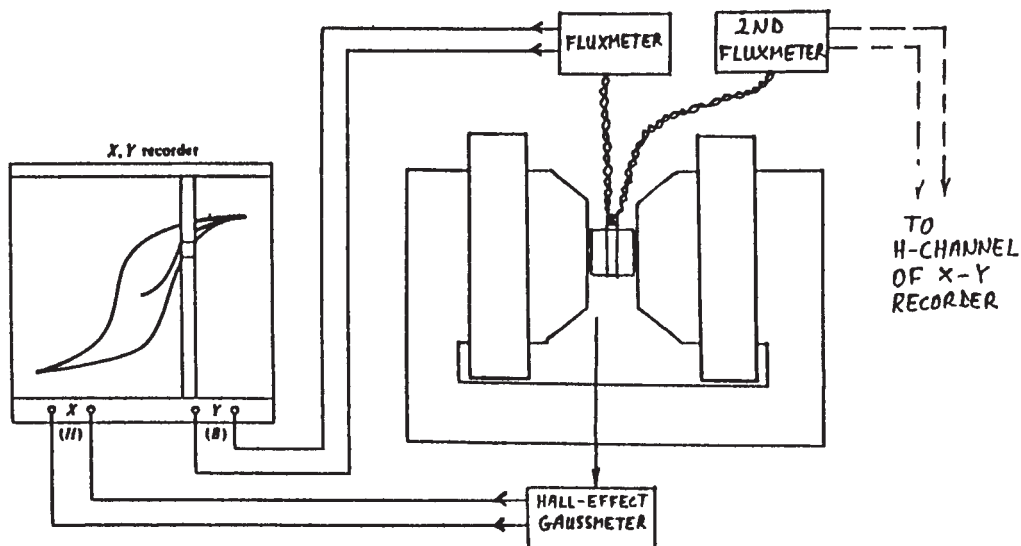

FIG. 5 Schematic Representation of a Typical Magnetic Hysteresigraph Test System

magnetic disturbances and physical abuse, it can continue to serve as a transfer standard after having once been calibrated by NMR.

6.2.1.4 *Use of the remanent induction flux*, of a long, freestanding permanent magnet bar as a secondary standard. A close-fitting, short-search coil of exactly known turns count is placed in the center (neutral zone) of the much longer bar, the fluxmeter is zeroed and the coil removed to a field-free region of space. Alternatively, the coil can be fixed and the magnet removed. The reference magnet should be precision machined from a material having a low temperature coefficient and high chemical and flux stability, such as Alnico five or temperature compensated Sm, Gd-Co-based 2-17 magnets; it must be stabilized by magnetic and thermal cycling. Its average cross-sectional area must be known.

6.2.2 The preferred method for calibrating the entire flux-measuring subsystem (B_i or B circuits, comprising the sensing coil arrangement, integrator, and indicating or recording instrument) uses a physical standard of a shape and size similar to that of the specimen to be characterized. Pure nickel is an excellent reference material since nickel is magnetically soft and thus easily saturated, its saturation magnetization value and temperature variation are well known, and nickel has a saturation induction level in the range of most permanent magnets. Pure iron is sometimes used, especially when calibrating to measure only permanent magnets with the highest induction levels. The flux calibration standard is placed in the air gap of the electromagnet, using the same pole and sensing-coil geometry to be used in the measurement for which one is calibrating. A magnetizing field of the magnitude required to produce a known magnetization in the standard is applied, and using the sensitivity potentiometers of the integrator or recorder, the y deflection on the x,y recorder is adjusted to yield a convenient scale factor for B_i . The known magnetization at the applied field value, any temperature variation of this value, and the ratio of the cross-sectional areas of standard and test specimen must be taken into account.

6.2.3 For measurements on high- B , high- H_{ci} materials, and specimens of short magnetic length, the relatively complex calibration method of 6.2.2 yields better accuracy for B_i and B than the seemingly absolute, volt-second-based fluxmeter calibration of 6.2.1. It takes into account most of the self-demagnetizing effects, field and flux inhomogeneities as a result of specimen shape and air gaps at sample end faces, and also pole-piece saturation effects, since many of these occur similarly with the nickel standard and the magnet test specimen. Experience shows the error of B_i in this case to be $<2\%$ in the applied field range up to about 10 to 12 kOe [800 to 1000 kA/m].

NOTE 2—Pure nickel and pure iron are mechanically very soft and can be easily deformed by pressure from the electromagnet pole pieces or other forces. Such standards must be carefully protected by nonmagnetic pole spacers of matched length. They should also be frequently inspected and their dimensions carefully checked for evidence of abuse. The approach to saturation of nickel is sensitive to mechanical strain. Nickel and iron should be stress-relief annealed before being used as magnetic flux reference standards.

6.3 Magnetic Field:

6.3.1 The magnetic field sensor with associated instrumentation must be calibrated such that the total error in the system is within $\pm 2\%$. The method of calibration depends on the nature of the field-strength sensor used.

6.3.2 *Hall-Effect Field Meters*—These should be frequently recalibrated by placing the Hall probe in the cavity of a reference field source available from the instrument manufacturer and adjusting the electronic sensitivity controls to match the meter indication to the stated reference field strength. Such “standard magnets” comprise a stabilized permanent magnet in a small, rigidly constructed and shielded-iron circuit. They produce a stated field in the 100 to 5000 Oe [8 to 400 kA/m] range and are indirectly calibrated against a highly accurate NMR gaussmeter by their manufacturer. Hall meters can also be calibrated more directly against NMR or an accurate rotating-coil gaussmeter if a large-volume transfer magnet is available (see 6.2.1.3).

6.3.3 Some Hall probes exhibit significant nonlinearity in high fields. In this case, nominal field readings from a linear-scale meter or voltage output should be corrected using data, which the gaussmeter manufacturer normally supplies. Attention must also be paid to the often strong temperature dependence of the Hall-probe output.

6.3.4 *Inductive H-Measuring Systems Using Sensing Coils and Integrators*—The H coil may be placed in a large-volume, homogeneous and time-constant field of magnitude similar to the fields to be measured, for example, between 5 to 10 kOe [400 to 800 kA/m]. The source of this field may be a calibrated permanent magnet system (see 6.3.2) or an electromagnet with a stable current source. The field is precisely measured, the coil is then repeatedly removed and replaced while the H sensitivity of the electronic system is adjusted to match the recorder x -deflection, or other H -meter indication, to the reference field value.

6.3.5 Usually it is most convenient to produce this reference field with the hysteresigraph electromagnet and the pole-gap-coil configuration to be used in the subsequent specimen test. The field is then usually measured with a Hall gaussmeter that should be calibrated in accordance with 6.3.2. Instead of removing the coil, one can reverse the field polarity by reversing the electromagnet current.

6.4 *Simultaneous B (or B_i) and H Calibration Using Permanent Magnet Reference Specimens:*

6.4.1 Magnet producers and users often exchange permanent magnet specimens as a means of coordinating hysteresigraph measurements using magnets that are well characterized by the first party. The second party then must magnetize fully these specimens before the test and plot a demagnetization curve, repeating this procedure as needed. The sensitivity of the B or B_i measuring circuit is adjusted until the first party's B_r reading is reproduced, that of the H -measuring circuit is adjusted to reproduce the initial H_c or H_{ci} value. This is not an absolute calibration, but it is a convenient method to transfer a good calibration from one instrument to another if one party does not have the facilities for an absolute calibration.

6.4.2 The magnet material used for a secondary transfer standard must meet certain conditions. It must have sufficiently low coercivity and saturation field strength, such that each

party can fully saturate it in their test system electromagnet; its properties must show good temporal stability; the properties should not vary strongly with temperature around +23°C. It should be mechanically strong and insensitive to physical abuse, and it should not corrode. Alnico five and several other materials of the Alnico and Fe-Cr-Co families meet these conditions. Ferrites are less suitable because of their brittleness and high-temperature coefficients. Most rare-earth magnets are too difficult to saturate and some corrode too readily.

7. Test Specimens

7.1 The test specimens shall have a simple shape such as a cylinder (to be magnetized in the axial direction) or a rectangular prism. The maximum dimensions are determined by the electromagnet pole-cap dimensions and Eq A1.1 and Eq A1.2. The minimum specimen length should be 0.20 in. [5 mm]. The end faces must be parallel to each other and perpendicular to the magnetization axis. The sample cross section must be uniform over the specimen length, any variations being less than 1 %. These conditions may require grinding of the sample. The average cross section must be measured to within ± 0.5 %. In the case of anisotropic material, the direction of magnetization should be marked on the specimens.

8. Procedure

8.1 Common Setup:

8.1.1 The following description of typical test procedures assumes that the compensated B_i -coil assembly, if used, has been first electronically balanced for zero integrated output when the empty coil assembly is placed in the air gap and the field is swept. It also assumes that the H and B or B_i -measuring circuits have been calibrated by appropriate methods chosen from Section 6.

8.1.2 The gap of the electromagnet is adjusted to the correct length for the specimen to be measured. The B integrator is connected to the B - or B_i -sensing coil; the H integrator, if used, to the H -sensing coil. The gap field strength, typically measured by a Hall probe, is brought as close as possible to zero by adjusting the excitation current of the electromagnet.

8.2 Initial Magnetization Curve:

8.2.1 Both integrators are zeroed. The demagnetized sample is inserted into the sensing coil assembly and the assembly plus specimen placed in the air gap. The pole pieces are closed on the sample and locked in that position. With small or fragile specimens, the gap distance should additionally be fixed using nonmagnetic spacers to avoid crushing the sample or damaging the sensing coils.

8.2.2 A magnetizing field is now applied and gradually increased to the maximum required level while the curve is plotted. A first quadrant cycle (zero field – maximum magnetizing field – zero field) should be run in no less than 10 s, and may take up to a minute or more if integrator stability is adequate. Running a loop too fast can result in significant errors as a result of eddycurrents and magnetic aftereffect.

8.3 Demagnetization Curve—Sample Magnetized in the Yoke:

8.3.1 The procedure of 8.2 is first followed. If the specimen was magnetized previously it may be important to apply the initial forward field in the marked prior magnetization direc-

tion. When a magnetized specimen is inserted in the coil, the self-demagnetizing field puts the measured (B, H) point in the second quadrant. Placing coil and specimen in the electromagnet then shifts the point closer to $H = 0$ and possibly into the first quadrant, depending on any remanent induction present in the poles and yoke iron.

8.3.2 A positive (forward) magnetizing field is applied, taking the B, H point farther into the first quadrant. The field is increased to the desired maximum (or the highest available) value in several seconds, then rapidly reduced to zero. At zero current, the residual magnetization state will still be in the first quadrant because of the remanent magnetization of poles and yoke.

8.3.3 The current then is reversed and increased, producing an increasingly negative field, until the H value exceeds the coercive field H , if only the second quadrant B, H is needed, or H_{ci} , if the full intrinsic curve is desired. With high-coercivity *RE-TM* magnets, the maximum available demagnetizing field may be less than H_{ci} so that only an incomplete second-quadrant curve can be measured.

8.3.4 The time rate of change of the magnetic field shall be sufficiently slow to avoid curve distortions as a result of a (sometimes pronounced) delayed response of B to the driving H change, but it shall be fast enough to avoid errors caused by integrator time constant and drift. Often it is helpful to provide a variation of the field-sweep rate such that the field changes rapidly when B_i remains nearly constant, but slows down when the intrinsic induction changes rapidly. Typical sweep times through the second quadrant are 15 s to several minutes.

8.4 Demagnetization Curve—Sample Magnetized Externally:

8.4.1 Materials with very high coercivity are often pulse magnetized externally and then transferred in open circuit to the hysteresigraph (see Annex A2). The direction of magnetization must be marked on the sample. Specimens with length-to-diameter ratios greater than two are preferred since the irreversible self-demagnetization of a short specimen can influence the accuracy of the results.

8.4.2 The general procedure of 8.3 is followed except that the initial forward magnetizing field strength shall always be the maximum available.

8.5 Recoil Lines, Loops, and Loop Fields:

8.5.1 To reach the starting point (B_{rec}, H_{rec}) of the recoil line on the major demagnetization curve (see Fig. 3), the procedure in 8.3 is used, but when H_{rec} is reached, the magnetizing current is reversed and its magnitude decreased again. The $|H|$ is thus reduced by ΔH , B increased by ΔB , and $\mu_{rec} = \Delta B / \Delta H$ can be calculated. Since μ_{rec} usually is not constant along the demagnetization curve and also depends on the extent of the recoil, the values H_{rec} , B_{rec} , and ΔH must be indicated (see also 4.3).

8.5.2 To plot a recoil loop field, $|H|$ is again increased (closing the first recoil loop) to a new, larger value of $|H_{rec}|$, and the procedure in 8.5.1 is repeated. In a typical recoil loop field, either all loops have the same ΔH , or all loops recoil fully to $H = 0$. Any number of recoil curves may be plotted, but accuracy is lost as a result of integrator drift accumulation with increasing plotting time.

8.5.3 Sometimes the same increment ΔH , from the same value of H_{rec} , is recycled several times to determine a (usually small) asymptotic reduction of the associated B or B_i values. Such cycling is used to stabilize the operating conditions in certain critical applications of permanent magnets.

9. Report

9.1 The report shall contain a reference to the appropriate sections of this test method and report the following information:

9.1.1 The material, shape, and dimensions of the test specimen, its identification code/number; orientation of the magnetically preferred axis or plane, if any; and orientation of the forward magnetizing field.

9.1.2 The type of electromagnet (yoke) and instrumentation used, by manufacturer and model number when possible.

9.1.3 The sensing methods used to measure B and H (that is surrounding coil or embedded pole coil for B , coaxial coil, side-by-side coil, Hall effect probe, or embedded pole coil for H).

9.1.4 The temperature of the test specimen during measurement.

9.1.5 The maximum magnetizing field applied before the measurement. State whether the field was applied in the yoke, or externally as a pulsed field (specify peak, half-width or pulse, number of pulses), or from a superconducting magnet.

9.1.6 The demagnetization curve and, if measured, recoil loops, or the initial magnetization curve, or both. For an initial magnetization curve of very high-coercivity magnets, the

magnetic history of the specimen shall be described, and whether thermally or field demagnetized.

9.1.7 The residual induction, B_r , at $H = 0$.

9.1.8 The coercive field H_c and, if measured, H_{ci} .

9.2 The maximum energy product $(BH)_{max}$. If desired, a curve plotting (BH) versus B , correlated with the B,H -curve, also may be presented.

9.3 The values B_d and H_d corresponding to the $(BH)_{max}$.

9.4 The recoil permeability, μ_{rec} , with B_{rec} , H_{rec} , and ΔH .

9.5 In the case of strong aftereffects, details of the test sequence shall be stated.

9.6 A statement about uncertainty of the measurements.

10. Precision and Bias

10.1 In the case of the procedures described in this test method, it is not always possible to refer to fundamental principles. The final bias of the test apparatus is a complex function of the measuring instruments and sensing components used and of other features of the measuring environment. Therefore, it is not often possible to state the absolute bias that can be attained. See Practice E 177.

10.2 In general, the reproducibility of the measurement of the intrinsic induction, B_i ; magnetic induction, B ; and magnetic field strength, H , is about +1 to +2 %.

11. Keywords

11.1 coercive field strength; coercivity; hysteresigraph; induction; magnetic; magnetic material; magnetic test; permanent magnets; permeameter; remanence

ANNEXES

(Mandatory Information)

A1. ELECTROMAGNET CONDITIONS AFFECTING MEASUREMENT ACCURACY

A1.1 Field Uniformity

A1.1.1 To ensure the field uniformity necessary for an accurate measurement, the pole faces of the electromagnet must be magnetic equipotential surfaces. For the magnetizing field to be as uniform as possible in the space occupied by the test specimen and the associated H and B sensors, the following approximate geometrical conditions must be fulfilled simultaneously (see Fig. A1.1):

$$d_1 > d_2 + 1.2 l \quad (A1.1)$$

$$d_1 > 2.0 l \quad (A1.2)$$

where:

d_1 = diameter at the gap of a circular pole piece or the shortest dimension of a rectangular pole piece,

l = distance between the pole faces (air gap length), and

d_2 = diameter of a cylinder volume within which specimen and sensors are located and field uniformity is required.

A1.1.2 With reference to the field strength at the center of the air gap, Eq A1.1 ensures that the field decrease at a radial distance of $d_2/2$ is <1 % and Eq A1.2 ensures that the field

increase along the axis of the electromagnet at the pole faces is <1 %. This degree of uniformity prevails in the air gap as long as the pole faces are magnetic equipotential lines. That is the case when the induction in the pole pieces is everywhere substantially lower than the saturation of the material of the pole pieces, so that the pole-face permeability remains high. In practice, this is true when the induction is less than about 10 kG [1 T] in iron and 12 kG [1.2 T] in Fe-Co alloy. For some permanent magnet materials with high remanence or high intrinsic coercivity, or both, local induction values much higher than 10 to 12 kG [800 to 1000 kA/m] can occur, saturating portions of the pole pieces near the test specimen end faces. The pole faces are then no longer equipotential surfaces, and pronounced inhomogeneities of H and B in and near the test specimen will develop, destroying the field uniformity even in the region defined by Eq A1.1 and Eq A1.2. When these values are locally exceeded under the combined influence of the exciting current of the electromagnet and the magnetized specimen, the field uniformity suffers, the specimen becomes nonuniformly magnetized, and the magnetization or demagnetization curves can become severely distorted at the higher H

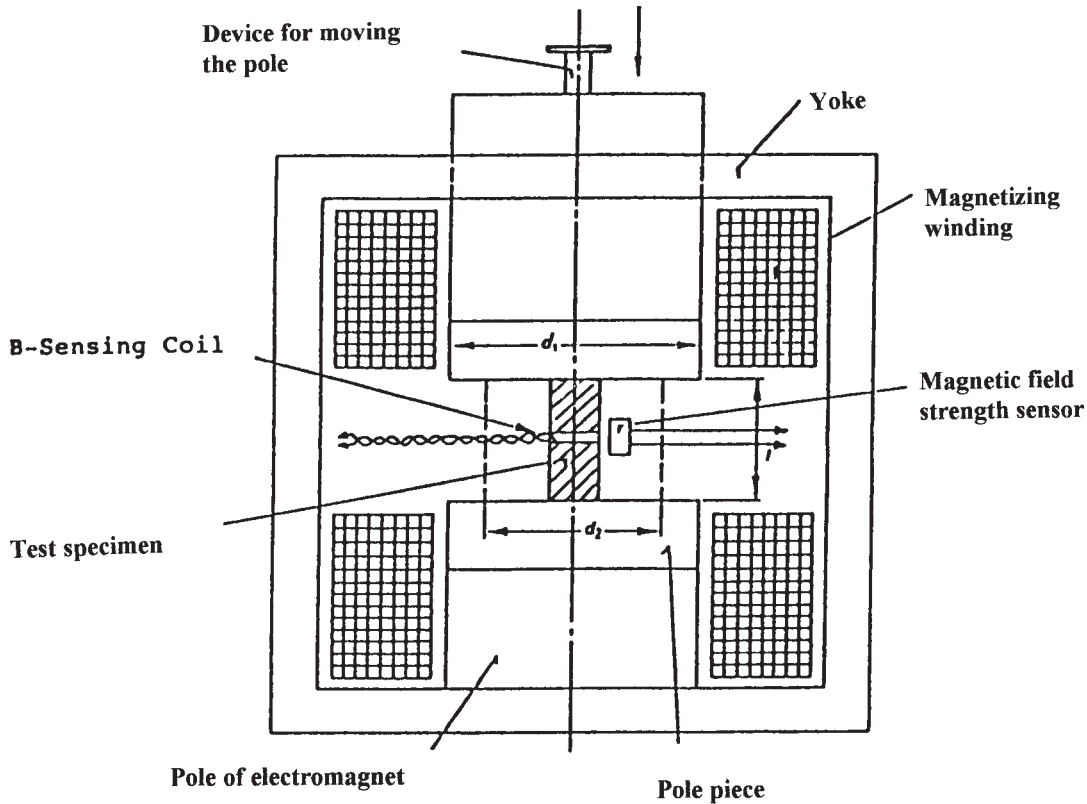

FIG. A1.1 Diagram of an Electromagnet

levels. In view of this, the accuracy of demagnetization curves is usually satisfactory between B_r and H_c for all current permanent magnet materials, but it is adversely affected in the

field range between H_c and H_{ci} for the highest coercivity magnets. Measured values of H_k and $(B_r/H)_{max}$, are too low, but H_{ci} is nearly unaffected by pole-face saturation.

A2. MAGNETIZATION OF A TEST SAMPLE AND MAGNETIC HISTORY

A2.1 Magnetizing (Charging)

A2.1.1 For use in a device, a magnet must be magnetized (charged), usually fully (to saturation), but often on purpose incompletely to calibrate or stabilize, or both, the field the magnet generates. With very high-coercivity materials, especially rare-earth permanent magnets such as Sm-Co and Nd-Fe-B, the charging field available to magnet producer or user often is too low to develop the best possible properties (see Table A2.1). If full saturation is not achieved, the properties depend on the charging field value. The demagnetization curve then may be influenced by earlier magnetization states, which a specimen experienced before charging and testing.

A2.1.2 To determine if full saturation is achieved, it is recommended to magnetize the test specimen with successively higher values of the magnetizing field strength, measuring a demagnetization curve to H_{ci} after each charging step. Each higher field must be applied in the same, original forward direction and must exceed the highest preceding opposite field value. The specimen is considered to be saturated if an increase

TABLE A2.1 Approximate Values of the Magnetizing Field Needed to Fully Saturate Typical Commercial Permanent Magnets of Different Material Types

MMPA Designation	Material		
	IEC Designation	[kA/m]	Oe
Alnico 2, 3, isotropic	R1-0-1 to 4	[160]	2 000
Alnico 5, 6, anisotropic	R1-1-1 to 4	[240]	3 000
Alnico 8, 9, anisotropic	R1-1-5 to 7	[480]	6 000
PtCo		[1500]	19 000
FeCo Cr 1 and 2	R6	[200]	2 500
FeCo Cr 250	R6	[80]	1 000
FeCo Cr	R6	[80]	1 000
FeCo Cr 5	R6	[240]	3 000
Rare-earth cobalt	R5-1	[3200]	40 000
	R5-2	[3200]	40 000
Nd-Fe-B		[4000]	50 000
Ceramic 1 (ferrites)	S1-0-1	[800]	10 000
Ceramic 5 - 8	S1-1-2 to 6	[800]	10 000

in the magnetizing field strength of 50 % changes the values of B_r , H_k , and H_{ci} by less than 1 %.

NOTE A2.1—This practical definition for saturation for permanent

magnets differs from the classical textbook definition which considers only B_i in the first quadrant on the initial magnetization curve.

A2.2 Magnetic History

A2.2.1 It can be important to predetermine and document the magnetic history of the test specimen, matching it to the magnetization states imposed during production of magnets for the intended application. Some possible specimen states are: thermally demagnetized (virgin); previously saturated and dc field demagnetized (must note prior flux direction); fully or partially demagnetized by combined application of heat and a dc field; and subjected to prior field cycling between unsaturated states, for example, in hysteresigraph testing.

A2.2.2 The test protocol should specify the initial magnetization state of the sample and the magnitude of the magnetizing field to be applied in a defined “forward direction” (corresponding to the first quadrant of the hysteresis loop) before a demagnetization curve is plotted. Sometimes the properties after charging to a specified less-than-saturated state have to be measured for predicting device performance. It is always desirable also to determine the best possible magnet properties, achieved only after full saturation.

A2.3 Magnetizing Within and External to the Test System

A2.3.1 For many materials and specimen shapes, the electromagnet of the hysteresigraph itself can produce the required magnetizing field strength. But for rare-earth permanent magnet materials, the test specimen must be magnetized in a separate device capable of generating higher field strengths, in the range from 35 to 100 kOe [2.8 to 8 MA/m], before testing. Pulsed-field magnetizers are commonly used for this, and

superconducting magnets have also been used. Test procedures for both cases are described in Section 8, subject to the conditions discussed in Annex A1. Only materials having sufficiently high H_{ci} and a recoil permeability near one, for example, most rare-earth permanent magnets and ferrite magnets, can be magnetized in open circuit and transferred into the hysteresigraph yoke without significant self-demagnetization. The charging pulse duration must be long enough to ensure uniform magnetization despite eddy current shielding in metallic magnets. Repeated pulsing may be required for specimens of large cross section. Externally charged specimens shall be inserted into the test-system electromagnet, such as to ensure magnetization in the same direction. The highest available forward magnetizing field shall then be reapplied before demagnetization curves are plotted.

A2.3.2 An approximate empirical relationship exists between the value of the field strength required to saturate, H_{max} , and the intrinsic coercivity, H_{ci} , as follows:

$$H_{max} = k H_{ci} \quad (A2.1)$$

where:

The coefficient k varies according to the nature of the magnet material and the degree of orientation. Generally it is between three and five, with isotropic magnets requiring higher magnetizing fields than their anisotropic versions (see also Table 1).

A2.3.3 Care must be taken that the magnetizing process does not heat the specimen excessively and that the specimen is again at the intended measurement temperature before testing. Room-temperature magnetization curves should be measured at a temperature in the range $23 \pm 5^\circ\text{C}$. The actual temperature of the test specimen shall be measured to $\pm 1^\circ\text{C}$ and reported.

APPENDIXES

(Nonmandatory Information)

X1. ELECTROMAGNET OR MAGNETIZING YOKE

X1.1 Yoke Design and Construction

X1.1.1 The hysteresis loop measurements are carried out by placing the specimen in the air gap of an electromagnet, often called the yoke, which has the dual purpose of generating the magnetizing/demagnetizing field and providing a low-reluctance flux closure path. The electromagnet and test specimen should form a closed ferromagnetic circuit. Pole pieces, pole cores, and return yoke of the electromagnet are made of magnetically soft material and designed to operate well below magnetic saturation so that the permeability remains reasonably high. The yoke shall be of symmetrical construction (see Fig. A1.1), preferably an H -frame design as shown. Single-sided C -frame yokes can be used. They introduce some magnetic asymmetry and are mechanically less sturdy. Also in use are open frames with four steel posts as the flux return path. At least one pole piece shall be movable to allow minimizing of undesirable air gaps between specimen

and pole caps. The end faces of both poles shall be flat, ground closely parallel to each other, and perpendicular to the pole axis.

X1.1.2 The pole pieces usually have a round cross section and often have interchangeable pole caps. These can be tapered (truncated cones) to concentrate the flux and increase the ultimate field achievable in the air gap and specimen but at the expense of field uniformity. At saturation, their optimum vertex angle is 109.5° , however, an angle of 120° commonly is used. The coercive field of yoke and pole materials should be less than 1.25 Oe [100 A/m]. Materials such as pure iron, low-carbon steel, or silicon steel are used. The tips of conical poles are often high saturation iron-cobalt alloy (35 to 50 % Co) which increases the limiting gap field by about 2 kOe [160 kA/m]. For certain scientific measurements, the yoke and poles can be laminated to minimize eddy currents, reduce the time lag of field behind exciting current, and improve dynamic field

uniformity during rapid field sweeps. In this configuration, the poles typically have a rectangular cross section, and the tapered pole caps are truncated pyramids.

X1.1.3 The electromagnet is excited by a dc current in two magnetizing coils, which are arranged symmetrically, and as close as practicable to the test specimen (see Fig. 5). The axis

of the specimen shall be in line with the axis of the magnetizing coils, as closely as possible. If non-surrounding H -sensing coils or Hall probes of large dimensions relative to the specimen cross section must be used, the entire specimen-plus-sensor complex shall be centered on the axis of the magnetizing coils.

X2. MAGNETIZATION CURVES AND SALIENT PROPERTIES

X2.1 Magnetization Curves of Permanent Magnets

X2.1.1 Magnetization curves and hysteresis loops for high-coercivity permanent magnets are commonly presented in the two different ways illustrated in Fig. 1: as the normal curves plotting B versus H or the intrinsic curves $(B-H) = 4\pi M = B_i$ versus H . The two presentations are equivalent, and one curve can be derived from the other, but it is seen that in the first and third quadrants, the intrinsic curves yield more compact graphs. In the second quadrant, most useful for the device designer, the two curves offer different conveniences, and both should be presented. For very high-coercivity magnet materials, the curves should not be determined in two separate, sequential magnetizing cycles, since it is often impossible to restore the initial magnetization state before the second field cycle. The curves must then be derived from data obtained in a single-field sweep. Each curve is obtainable from the other by numerical or electronic signal addition/subtraction in accordance with Eq X2.1 and Eq X2.2.

$$B = H + B_i = H + 4\pi M \text{ (customary units)} \quad (\text{X2.1})$$

$$(B = \mu_0 H + B_i) \text{ (SI units)} \quad (\text{X2.2})$$

X2.1.2 Fig. 1 shows two extreme cases of initial magnetization curves found in permanent magnets, the one rising steeply from the origin, the other remaining almost horizontal up to fields near H_{ci} . These virgin curve shapes relate to the mechanism of domain wall motion, and thus, are important in research. They also convey information about the magnetic field strength needed to fully magnetize a magnet, which is required for efficient device manufacture, especially with rare-earth permanent magnets.

X2.2 Demagnetization Curves and Salient Properties

X2.2.1 Fig. 2 shows the second quadrant of Fig. 1 enlarged and with more detail. Such demagnetization curves are the most-used means of characterizing permanent magnets. The common intercept of both curves with the ordinate axis $H = 0$, defines the residual induction, B_r (remanent magnetic induction or remanence), identical to the residual intrinsic induction. The intercept of the B , H -curve with the abscissa, $B = 0$, defines the normal coercive field, H_c (also ${}_B H_c$). The intercept of the B_i , H curve with the H axis defines the intrinsic coercive field, H_{ci} (also called ${}_M H_c$, ${}_i H_c$ or ${}_J H_c$).

NOTE X2.1—The term coercive force is now replaced by the term coercive field. Coercive force derives from the obsolete term magnetizing force for magnetic field strength. Often it is used interchangeably with the term coercivity. These terms, however, should be distinguished. The values of the coercive fields depend on the forward magnetizing field applied, especially the H_{ci} of high-coercivity materials such as rare-earth permanent magnets. The term coercivity should be reserved for the

maximum possible value of the coercive field, on the major demagnetization curve, achieved only after applying a sufficiently high forward field.

X2.2.2 The general shape of the intrinsic demagnetization curve for high-coercivity magnets also depends on the prior magnetizing history. A quantity called Knee Field, H_k , is used to describe the flatness of the (B_i, H) curve in the high- B region (loop squareness) by a single number. H_k is defined as the demagnetizing field strength at which the remanent intrinsic induction is 10 % lower than the residual induction, $B_{id} = 0.9 B_r$.

X2.2.3 The (static) energy product, $(BH)_{\max}$, is the maximum value of the product of corresponding values of B and H at a point on the normal demagnetization curve. Commonly, it is used as a figure-of-merit for comparing the utility of different magnet materials in many static magnetic circuits. Other energy-figures-of-merit are in use for different dynamic application categories. One is the intrinsic energy product, $(B_i H)_{\max}$, the maximum value of the product of corresponding B_i and H values on the intrinsic demagnetization curve.

X2.3 Temperature Effects

X2.3.1 Room-temperature magnetization curves shall be measured at a temperature in the range $23 \pm 5^\circ\text{C}$. The actual temperature of the test specimen shall be measured $\pm 1^\circ\text{C}$ and reported.

X2.3.2 For measuring curves at different temperatures the specimen is surrounded by a heated or cooled chamber and pole caps, which are thermally insulated from the electromagnet pole core. The temperature shall be measured using a nonmagnetic sensor that is in direct contact with the specimen (preferred) or with the sample holder or with one pole cap of the electromagnet where these touch the specimen.

X2.4 Recoil Lines and Recoil Permeability

X2.4.1 Recoil lines are minor loops with a starting point $(H_{\text{rec}}, B_{\text{rec}})$ on the major demagnetization curve, traversed when the direction of field change is reversed. A decrease of $|H|$ by an increment ΔH causes B to increase by ΔB (see Fig. 3).

X2.4.2 The recoil permeability is defined as:

$$\mu_{\text{rec}} = \Delta B / \Delta H \text{ (customary units)} \quad (\text{X2.3})$$

$$\mu_{\text{rec}} = \Delta B / (\mu_0 \Delta H) \text{ (SI units)} \quad (\text{X2.4})$$

where:

ΔH can vary from a very small increment (μ_{rec} then becomes the reversible permeability, μ_{rev}) to $\Delta H = H_{\text{rec}}$, a condition called full recoil. The minor loops traced when H is cycled through ΔH are often approximated by straight recoil lines with a slope drawn through their tips. However, in reality, they are hysteresis loops with curved branches, and they get wider

and steeper with increasing ΔH . The value of μ_{rec} depends on (H_{rec}, B_{rec}) and ΔH . These values must be recorded along with H_{rec} .

X2.4.3 To provide full information for optimum dynamic device design, recoil-loop fields are sometimes required com-

prising several evenly spaced minor loops covering the range of interest, generally from $H_{rec} = 0$ to a value of $|H_{rec}|$ somewhat greater than $|H_c|$.

ASTM International takes no position respecting the validity of any patent rights asserted in connection with any item mentioned in this standard. Users of this standard are expressly advised that determination of the validity of any such patent rights, and the risk of infringement of such rights, are entirely their own responsibility.

This standard is subject to revision at any time by the responsible technical committee and must be reviewed every five years and if not revised, either reapproved or withdrawn. Your comments are invited either for revision of this standard or for additional standards and should be addressed to ASTM International Headquarters. Your comments will receive careful consideration at a meeting of the responsible technical committee, which you may attend. If you feel that your comments have not received a fair hearing you should make your views known to the ASTM Committee on Standards, at the address shown below.

This standard is copyrighted by ASTM International, 100 Barr Harbor Drive, PO Box C700, West Conshohocken, PA 19428-2959, United States. Individual reprints (single or multiple copies) of this standard may be obtained by contacting ASTM at the above address or at 610-832-9585 (phone), 610-832-9555 (fax), or service@astm.org (e-mail); or through the ASTM website (www.astm.org).