



Standard Test Method for Measuring Changes in Height of Cylindrical Specimens of Hydraulic-Cement Grout¹

This standard is issued under the fixed designation C 1090; the number immediately following the designation indicates the year of original adoption or, in the case of revision, the year of last revision. A number in parentheses indicates the year of last reappraisal. A superscript epsilon (ϵ) indicates an editorial change since the last revision or reappraisal.

1. Scope

1.1 This test method covers measurement of the changes in height of hydraulic-cement grout by the use of 75 by 150-mm (3 by 6-in.) cylinders, when the cylinders are protected so that the tendency to change in height does not include evaporation so as to cause drying, uptake of moisture, carbonation, or exposure to temperatures outside the range $23 \pm 2.0^\circ\text{C}$ ($73 \pm 3^\circ\text{F}$) or, optionally, to another specified temperature controlled within $\pm 2.0^\circ\text{C}$ ($\pm 3^\circ\text{F}$).

1.2 If desired, this test method can be adapted to studies of changes in height involving either schedules or environmental treatment different from the standard procedures prescribed by this test method.

1.3 The values stated in SI units are to be regarded as the standard.

1.4 *This standard does not purport to address all of the safety concerns, if any, associated with its use. It is the responsibility of the user of this standard to establish appropriate safety and health practices and determine the applicability of regulatory limitations prior to use.*

2. Referenced Documents

2.1 ASTM Standards:

- C 125 Terminology Relating to Concrete and Concrete Aggregates²
- C 172 Practice for Sampling Freshly Mixed Concrete²
- C 305 Practice for Mechanical Mixing of Hydraulic Cement Pastes and Mortars of Plastic Consistency³
- C 511 Specification for Moist Cabinets, Moist Rooms, and Water Storage Tanks Used in the Testing of Hydraulic Cements and Concretes^{2,3}
- C 670 Practice for Preparing Precision and Bias Statements for Test Methods for Construction Materials²
- C 827 Test Method for Change in Height at Early Ages of Cylindrical Specimens from Cementitious Mixtures²
- C 939 Test Method for Flow of Grout for Preplaced-Aggregate Concrete (Flow Cone Method)²

¹ This test method is under the jurisdiction of ASTM Committee C09 on Concrete and Concrete Aggregates and is the direct responsibility of Subcommittee C09.68 on Volume Change of Concrete.

Current edition approved June 10, 2001. Published September 2001. Originally published as C 1090 – 88. Last previous edition C 1090 – 96.

² *Annual Book of ASTM Standards*, Vol 04.02.

³ *Annual Book of ASTM Standards*, Vol 04.01.

C 1107 Specification for Packaged Dry, Hydraulic-Cement Grout (Nonshrink)²

3. Terminology

3.1 Definition of Term Specific to This Standard:

3.1.1 *change in height*—either an increase or decrease in the vertical dimension of a test specimen, provided the change has been caused by factors other than externally applied forces, changes in ambient temperature not conforming to the specified range, drying caused by evaporation, carbonation, or uptake of moisture.

4. Significance and Use

4.1 This test method is intended to provide a means of assessing the ability of a hydraulic-cement grout to retain a stable volume during the stipulated testing period of 28 days, provided that the tendency to change height does not include the effects of drying caused by evaporation, uptake of moisture, carbonation, or exposure to temperatures outside the range $23.0 \pm 2.0^\circ\text{C}$ ($73 \pm 3^\circ\text{F}$) (Note 1). An exception is made when the options described in the section on test conditions are exercised.

NOTE 1—This test method does not measure the change in height before hardening (see Test Method C 827).

5. Apparatus

5.1 *Cylinder Molds*⁴ steel cylindrical molds with minimum wall thickness of 6 mm ($\frac{1}{4}$ in.) fitted with clamp assemblies for closing, 75 mm (3 in.) $\pm 1\%$ in inside diameter by 150 mm (6 in.) $\pm 2\%$ in height (Note 2), fitted with a removable 6-mm ($\frac{1}{4}$ -in.) steel base plate that can be clamped in place with the cylinder molds, top edge machined to a narrow rim as shown in Fig. 1.

NOTE 2—Satisfactory molds can be made from lengths of steel tubing or pipe that is slit on one side parallel to the longitudinal axis and fitted with a means of closing the vertical slit as well as a means of attaching a base plate.

5.2 *Glass Plate*⁴ approximately 100 mm (4 in.) square by 6 mm ($\frac{1}{4}$ in.) thick, coated as thinly as possible on one surface

⁴ Humboldt Mfg. Co., 7302 Agatite Ave., Chicago, IL 60656, Catalog Numbers H-2902 Depth Micrometer, H-2904 Tapered Cylinder Mold, H-2931.2 Glass Plate, H-2931.3 Weight, and H-2903 Set (including all the preceding items) have been found satisfactory.

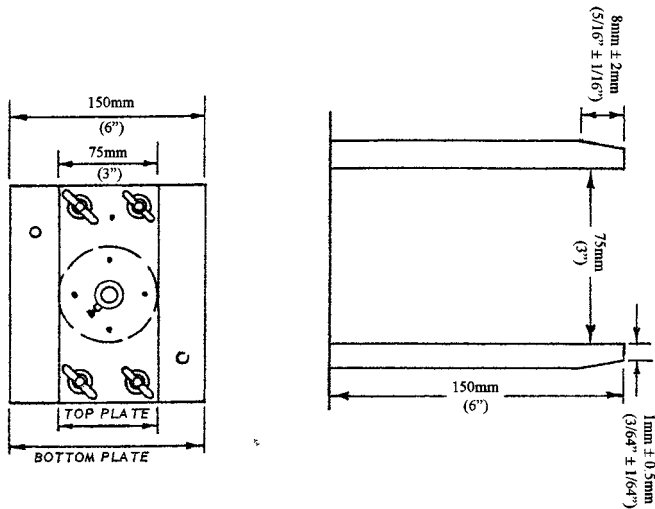

FIG. 1 Cylinder Mold with Machined (Tapered) Top Edge

with a silicone-base spray⁵ or other inert material such as mineral oil, and permitted to dry before use.

5.3 *Hold-Down Weight*⁴ having a mass of 1.5 kg (3 lb.) ± 1 %.

5.4 *Micrometer Bridge*⁴ designed to support and hold one cylinder in a level, firm position (Fig. 2), with steel rods, and a top made of noncorroding metal, not more than 1 mm (³/₆₄ in.) larger than the diameter of the measuring shaft of the micrometer depth gage, and numbered 1 to 4 (Note 3).

NOTE 3—The four holes should be 30 ± 2 mm (1¼ ± 1/64 in.) from the center of the hold-down device.

5.5 *Micrometer Depth Gage*⁴ having a range from 25 to 50 mm (1.000 to 2.000 in.) graduated in units not larger than 0.02 mm (0.001 in.) (Note 4).

NOTE 4—The diameter of the shaft of the depth micrometer should be 3.0 ± 0.4 mm (1/8 ± 1/64 in.).

5.6 *Outside Micrometer Caliper*, used to measure the thickness of the plate, with a capacity of at least 12 mm (½ in.) and graduated in units not larger than 0.02 mm (0.001 in.) having throat depth of at least 50 mm (2.0 in.).

5.7 *Tamping Rod*, a straight steel rod with at least the tamping end rounded to a hemispherical tip of the same diameter as the rod, 10 mm (³/₈ in.) in diameter and at last 250 mm (10 in.) long.

5.8 *Mechanical Mixer*, as described in Practice C 305 (Note 5).

NOTE 5—This mixer has clearances between paddle and bowl that are suitable only for mortars made with fine aggregates that are finer than the 850-µm (No. 20) sieve. Mortars made with aggregates containing particles coarser than the 850-µm sieve may require special clearance or a different type of paddle to permit the mixer to operate freely and avoid damage to the paddle and bowl.

6. Preparation of Sample

6.1 Take a sample of the freshly mixed grout to be tested either in accordance with Practice C 172 or prepared in

⁵ Borden Chemical Co., No. 1325 Silicone Spray in aerosol cans has been found satisfactory.

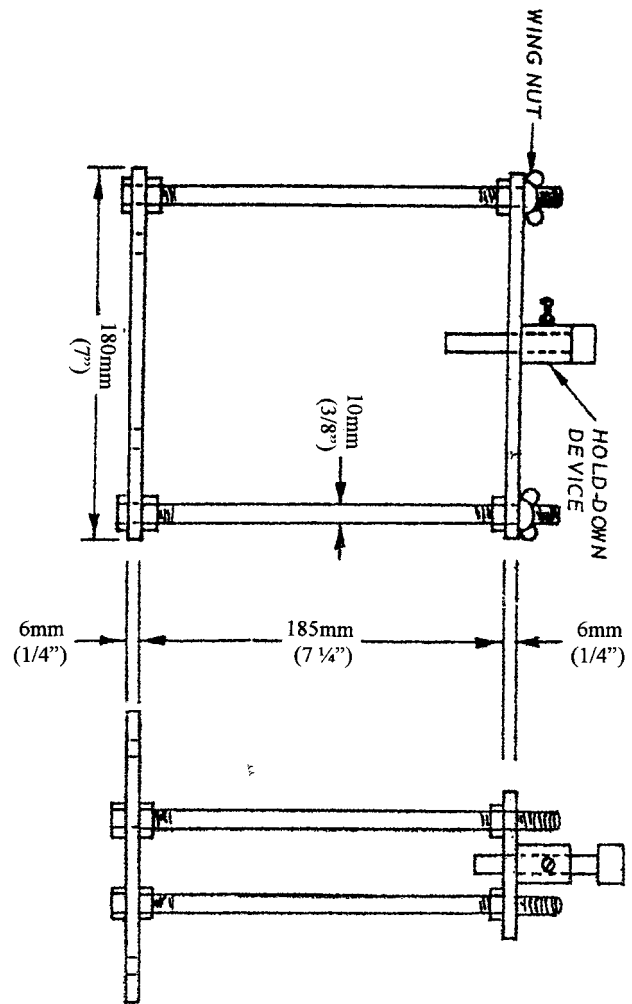

NOTE 1—All parts of this bridge shall be made of a noncorroding metal.

NOTE 2—The diameter of the measuring shaft of the depth micrometer shall be 3.0 ± 0.4 mm (1/8 ± 1/64 in.). The four holes should be 25 ± 1 mm (1 ± 1/16 in. from the center of the cylinder as shown in Fig. 1.

FIG. 2 Dimensions of Micrometer Bridge

sufficient quantity to permit molding at least one test specimen for height-change measurements and such additional tests as may be required or specified.

6.2 If the grout to be tested is blended from individual components, mix in accordance with Practice C 305 (Note 6). If the grout is made using a packaged product, proceed as follows, unless otherwise recommended by the manufacturer.

6.2.1 Use 3000 to 3500 g of dry material as required and the proportionate amount of water required for the test. Record amounts used.

6.2.2 Place mixing water in mixing bowl.

6.2.3 Add dry material during the first 30-s period while mixing at slow speed, 140 ± 5 r/min.

6.2.4 Continue mixing for 3 min, stopping the mixer for not over 15 s after 1 min to scrape down into the batch any grout that may have collected on the side of the bowl.

NOTE 6—If the grout contains fine aggregate, the mixing procedure for mortar is applicable; if it does not, that for paste is applicable.

6.3 Cast the sample and lock the glass plate, micrometer bridge, top plate, plunger, and weight into position within 4

min after completion of mixing. Complete the initial measurements within 3 min after completion of these operations.

6.4 If it is required or desired to cast the specimen after a longer holding period, continue mixing of either the whole or remaining portion, as appropriate, at slow speed for the specified time and the sample cast, apparatus locked, and take initial measurements within 3 min after completion of these operations.

7. Preparation of Apparatus

7.1 Coat the exterior seams of the cylinder mold and the exterior joint between the mold and the base plate with melted paraffin wax. Coat the interior of the cylinder mold and base plate lightly with mineral oil (Note 7). Attach the mold to the micrometer bridge.

NOTE 7—The exterior of the mold and the base plate may be coated with paraffin wax to facilitate cleanup after completion of the test.

8. Conditioning

8.1 Keep the air temperature at $23 \pm 2^\circ\text{C}$ ($73 \pm 3^\circ\text{F}$), and a relative humidity of not less than 50 %. Store the test specimen at a temperature of $23 \pm 2^\circ\text{C}$ for the duration of the test, unless otherwise specified. When it is desired to test the height change of material that is permitted to be used in the field at temperatures either below or above $23 \pm 2^\circ\text{C}$, use such other temperatures controlled to $\pm 2^\circ\text{C}$ (3°F) throughout instead of $23 \pm 2^\circ\text{C}$. Record the temperature of the mixing water, other materials, and of the mixture immediately after mixing is completed. Store the height-change apparatus in air at the desired test storage temperature within $\pm 2^\circ\text{C}$ before casting the specimen.

8.2 Protect the test specimen from loss of moisture, absorption of moisture, or reaction with carbon dioxide for the duration of the test. Store the specimen in the moist room or in laboratory air described as follows: Under either condition, the specimen shall remain protected at all times during the test for 28 days except during removal of the glass plate and the taking of measurements.

8.2.1 *Moist Room Storage*—Immediately after taking the initial measurements, cover the plunger and bridge apparatus with a plastic bag previously fitted and cut to a length that extends downward to the midpoint of the specimen mold to prevent water from dripping on the bridge, glass plate, or specimen. Then carefully place the specimen in a moist room or moist cabinet meeting the requirements of Specification C 511.

8.2.2 *Laboratory Air Storage*—Prior to casting the test specimen, place the entire apparatus in a prefitted plastic bag just large enough to be gathered and tied above the plunger and bridge. Roll down or collapse the bag so as not to interfere with the casting operation. Immediately after taking the initial measurement, place a damp, but not dripping, towel around the outside of the lower portion of the four posts supporting the bridge, inside the plastic bag. The towel shall extend upward, but not to more than half the height of the cylinder. Gather and tie the plastic bag just above the plunger and bridge.

8.2.3 *Subsequent Storage*—If after 28-days storage, as previously described, it is desired to observe height change while allowing some drying or carbonation, or both, to occur, remove

the specimen from the moist room, or from being protected by the plastic bag and damp towels, exposed to air at $50 \pm 4\%$ relative humidity and at the same temperature at which the test was previously maintained.

9. Procedure

9.1 Place the apparatus on a smooth, horizontal surface, which is free of vibration or disturbance. Remove the top of the bridge after it has been pre-leveled parallel to the top of the mold rim by using the four lower nuts.

9.2 Determine consistency in accordance with Test Method C 827. Consider mixtures having a flow of less than 100 % as “stiff plastic;” those having flows between 100 and 125 % are considered “plastic.” A “flowable” mixture shall have a flow between 125 and 145 % when tested in accordance with Test Method C 827, but not less than 30 s when tested in accordance with Test Method C 939. A “fluid” mixture shall have a flow of 10 to 30 s when tested in accordance with Test Method C 939.

9.3 When testing a material that does not flow easily into the mold, fill by using three equal layers, rod each layer 15 times with the tamping rod. When testing materials that flow easily into the mold, fill the mold and tap the side of the mold lightly three times with the tamping rod. Use sufficient material so that after consolidation the mold is slightly overfilled.

9.4 Carefully place the coated surface of the glass plate on top of the test specimen as follows: Hold the plate, coated side down, with the index finger placed in the center and the thumb and other fingers on two opposite edges. Bring the plate, held at an angle of approximately 45° , to the beveled edge of the cylinder mold at a point 12 mm ($\frac{1}{2}$ in.) from the lower edge of the plate. Using this contact point as a fixed hinge, lower the plate in a single motion until the excess material is extruded and full contact with the rim is established. Neither slide nor use the glass plate in a screeding motion, as this will either smear the material on the glass or cover voids, thus making their detection at this time difficult. After placing the glass plate, maintain contact between the plate and the rim until the plunger and weight have been placed.

9.4.1 Quickly examine the grout surface through the glass plate for voids. If there is an area larger than 3.2 mm ($\frac{1}{8}$ in.) in diameter which lacks contact with the plate, discard the entire test specimen (Note 8).

NOTE 8—In order to keep rejected test specimens to a minimum, operators conducting this operation for the first time have found it helpful to practice several times placing the plate on a cylinder filled with an easily available plain mortar before starting the test.

9.5 Immediately after placing the glass plate, place the preleveled top plate of the micrometer bridge in position, tighten wing nuts, and lower the plunger of the hold-down device until it makes contact with the top surface of the glass plate. To ensure firm contact between the plunger and the plate, place a 1.5-kg (3-lb) mass on the top of the plunger prior to the tightening of the setscrew of the plunger. Following the tightening of the setscrew, remove the mass and immediately insert the depth micrometer shaft through the four holes located on the top plate of the bridge until the finger rests are in full contact with it. Turn the shaft down and determine four initial measurements from this surface to the top surface of the glass plate covering the cylinder mold. Make measurements to the

nearest 0.02 mm (0.001 in.). Calculate the average; do not round the numerical value. While the shaft is still touching the glass plate, use a glass marker to make a circle around the contact areas as the points at which later plate-thickness measurements will be taken.

9.6 Release the plunger and remove the glass plate from the top of the test specimen $24 \pm \frac{1}{2}$ h after starting the mixing.

9.7 Immediately after removal, measure the thickness of the glass plate at the points of contact between the glass plate and the micrometer depth gage and record to the nearest 0.02 mm (0.001 in.).

9.8 At ages of $24 \pm \frac{1}{2}$ h, 3 days \pm 1 h, 14 days \pm 6 h, and 28 days \pm 12 h, measured from the time of contact of the dry materials and the mixing water, take four measurements directly to the top of the test specimen at the gage points. If the rod end of the depth micrometer either contacts the specimen surface within a bubble that has formed after placing the glass plate or breaks through the surface of a hidden bubble or other placing defect, discard the reading at that point. If less than three valid gage points remain, discard the test specimen. Measurements may be continued for additional specified periods of time. Calculate the average; do not round the numerical value.

9.9 On completion of measurements, carefully strip the test specimen and make careful visual examination of the cylindrical surface. Discard measurements made on a specimen that is cracked or otherwise manifestly faulty.

10. Calculation

10.1 To determine V_1 , correct the initial measurements by adding the thickness of the glass plate measured at each corresponding contact point. Calculate the height change in percent for each age to the nearest 0.01 %, using non-rounded values for V_1 and V_2 as follows:

$$V = \frac{V_1 - V_2}{H} \times 100 \quad (1)$$

where:

V = height change, %,

V_1 = average of at least three adjusted micrometer depth gage readings at beginning of test, mm (in.),

H = height, 152-mm (6-in.), and

V_2 = average of at least three-micrometer depth gage readings at test age, mm (in.).

11. Report

11.1 Report the calculated height change (either positive or negative) at each test age. Also report the temperature and relative humidity at which the tests were performed, mixture

proportions (if not prepackaged), as-mixed temperature, and consistency. Also report any deviations from the provisions given herein.

12. Precision and Bias

12.1 *Precision*—Based on an analysis of results of cooperative tests of three materials tested at two consistencies, stored at two storage conditions, it was concluded that separate precision statements are needed for flowable and fluid mixtures.

12.1.1 *Flowable Mixtures*—The single-operator standard deviation has been found to be 0.07 % (Note 9). This does not vary with test age (up to 28 days) or with expansion (over the range from 0.02 to 0.43 %). Therefore, results from two properly conducted tests by the same operator on the same material should not differ by more than 0.196 % (Note 9).

12.1.1.1 The multilaboratory standard deviation has been found to be 0.08 % (Note 9). This does not vary with test age (up to 28 days) or with expansion (over the range from 0.02 to 0.43 %). Therefore, results of two properly conducted tests on the same material in two laboratories should not differ by more than 0.216 % (Note 9).

12.1.2 *Fluid Mixtures*—The single-operator standard deviation has been found to be 0.11 % (Note 9). This does not vary with test age (up to 28 days) or with expansion (over the range from 0.11 to 0.33 %). Therefore, results of two properly conducted tests by the same operator on the same material should not differ by more than 0.3255 % (Note 9).

12.1.2.1 The multilaboratory standard deviation has been found to be 0.11 % (Note 9). This does not vary with test age (up to 28 days) or with expansion (up to 0.43 %). Therefore, results of two properly conducted tests on the same material in two laboratories should not differ by more than 0.30 % (Note 9).

NOTE 9—These numbers represent, respectively, the (1s) and (d2s) limits as described in Practice C 670.

12.2 *Bias*—No statement on bias is being made because there is no accepted reference material suitable for determining the bias in this test method.

13. Keywords

13.1 grout; height change; hydraulic cement; nonshrink grout

The American Society for Testing and Materials takes no position respecting the validity of any patent rights asserted in connection with any item mentioned in this standard. Users of this standard are expressly advised that determination of the validity of any such patent rights, and the risk of infringement of such rights, are entirely their own responsibility.

This standard is subject to revision at any time by the responsible technical committee and must be reviewed every five years and if not revised, either reapproved or withdrawn. Your comments are invited either for revision of this standard or for additional standards and should be addressed to ASTM Headquarters. Your comments will receive careful consideration at a meeting of the responsible technical committee, which you may attend. If you feel that your comments have not received a fair hearing you should make your views known to the ASTM Committee on Standards, at the address shown below.

This standard is copyrighted by ASTM, 100 Barr Harbor Drive, PO Box C700, West Conshohocken, PA 19428-2959, United States. Individual reprints (single or multiple copies) of this standard may be obtained by contacting ASTM at the above address or at 610-832-9585 (phone), 610-832-9555 (fax), or service@astm.org (e-mail); or through the ASTM website (www.astm.org).