



Standard Test Methods for Uncompacted Void Content of Fine Aggregate (as Influenced by Particle Shape, Surface Texture, and Grading)¹

This standard is issued under the fixed designation C 1252; the number immediately following the designation indicates the year of original adoption or, in the case of revision, the year of last revision. A number in parentheses indicates the year of last reapproval. A superscript epsilon (ε) indicates an editorial change since the last revision or reapproval.

1. Scope

1.1 These test methods describe the determination of the loose uncompacted void content of a sample of fine aggregate. When measured on any aggregate of a known grading, void content provides an indication of that aggregate's angularity, sphericity, and surface texture compared with other fine aggregates tested in the same grading. When void content is measured on an as-received fine-aggregate grading, it can be an indicator of the effect of the fine aggregate on the workability of a mixture in which it may be used.

1.2 Three procedures are included for the measurement of void content. Two use graded fine aggregate (standard grading or as-received grading), and the other uses several individual size fractions for void content determinations:

1.2.1 *Standard Graded Sample (Test Method A)*—This test method uses a standard fine aggregate grading that is obtained by combining individual sieve fractions from a typical fine aggregate sieve analysis. See the section on Preparation of Test Samples for the grading.

1.2.2 *Individual Size Fractions (Test Method B)*—This test method uses each of three fine aggregate size fractions: (a) 2.36 mm (No. 8) to 1.18 mm (No. 16); (b) 1.18 mm (No. 16) to 600 μm (No. 30); and (c) 600 μm (No. 30) to 300 μm (No. 50). For this test method, each size is tested separately.

1.2.3 *As-Received Grading (Test Method C)*—This test method uses that portion of the fine aggregate finer than a 4.75-mm (No. 4) sieve.

1.2.4 See the section on Significance and Use for guidance on the method to be used.

1.3 The values stated in SI units shall be regarded as the standard.

1.4 *This standard does not purport to address all of the safety concerns, if any, associated with its use. It is the responsibility of the user of this standard to establish appropriate safety and health practices and determine the applicability of regulatory limitations prior to use.*

¹ These test methods are under the jurisdiction of ASTM Committee C-9 on Concrete and Concrete Aggregates and are the direct responsibility of Subcommittee C09.20 on Normal Weight Aggregates.

Current edition approved May 10, 1998. Published December 1998. Originally published as C 1252 – 93. Last previous edition C 1252 – 93.

2. Referenced Documents

2.1 *ASTM Standards:*

B 88 Specification for Seamless Copper Water Tube²

B 88M Specification for Seamless Copper Water Tube [Metric]²

C 29/29M Test Method for Unit Weight and Voids in Aggregate³

C 117 Test Method for Material Finer Than 75-μm (No. 200) Sieve in Mineral Aggregates by Washing³

C 125 Terminology Relating to Concrete and Concrete Aggregates³

C 128 Test Method for Specific Gravity and Absorption of Fine Aggregate³

C 136 Test Method for Sieve Analysis of Fine and Coarse Aggregates³

C 670 Practice for Preparing Precision and Bias Statements for Test Methods for Construction Materials³

C 702 Practice for Reducing Samples of Aggregate to Testing Size³

C 778 Specification for Standard Sand⁴

D 75 Practice for Sampling Aggregates⁵

2.2 *ACI Document:*

ACI 116R Cement and Concrete Terminology⁶

3. Terminology

3.1 Terms used in these test methods are defined in Terminology C 125 or ACI 116R.

4. Summary of Test Method

4.1 A nominal 100-mL calibrated cylindrical measure is filled with fine aggregate of prescribed grading by allowing the sample to flow through a funnel from a fixed height into the measure. The fine aggregate is struck off and its mass is determined by weighing. Uncompacted void content is calculated as the difference between the volume of the cylindrical measure and the absolute volume of the fine aggregate collected in the measure. Uncompacted void content is calculated

² *Annual Book of ASTM Standards*, Vol 02.01.

³ *Annual Book of ASTM Standards*, Vol 04.02.

⁴ *Annual Book of ASTM Standards*, Vol 04.01.

⁵ *Annual Book of ASTM Standards*, Vol 04.03.

⁶ Available from the American Concrete Institute, Box 19150, Detroit, MI 48219.

using the bulk dry specific gravity of the fine aggregate. Two runs are made on each sample and the results are averaged.

4.1.1 For a graded sample (Test Method A or Test Method C) the percent void content is determined directly, and the average value from two runs is reported.

4.1.2 For the individual size fractions (Test Method B), the mean percent void content is calculated using the results from tests of each of the three individual size fractions.

5. Significance and Use

5.1 Test Methods A and B provide percent void content determined under standardized conditions which depends on the particle shape and texture of a fine aggregate. An increase in void content by these procedures indicates greater angularity, less sphericity, or rougher surface texture, or combination thereof. A decrease in void content results is associated with more rounded, spherical, or smooth-surfaced fine aggregate, or a combination thereof.

5.2 Test Method C measures the uncompacted void content of the minus 4.75-mm (No. 4) portion of the as-received material. This void content depends on grading as well as particle shape and texture.

5.3 The void content determined on the standard graded sample (Test Method A) is not directly comparable with the average void content of the three individual size fractions from the same sample tested separately (Test Method B). A sample consisting of single size particles will have a higher void content than a graded sample. Therefore, use either one method or the other as a comparative measure of shape and texture, and identify which test method has been used to obtain the reported data. Test Method C does not provide an indication of shape and texture directly if the grading from sample to sample changes.

5.3.1 The standard graded sample (Test Method A) is most useful as a quick test which indicates the particle shape properties of a graded fine aggregate. Typically, the material used to make up the standard graded sample can be obtained from the remaining size fractions after performing a single sieve analysis of the fine aggregate.

5.3.2 Obtaining and testing individual size fractions (Test Method B) are more time consuming and require a larger initial sample than using the graded sample. However, Test Method B provides additional information concerning the shape and texture characteristics of individual sizes.

5.3.3 Testing samples in the as-received grading (Test Method C) may be useful in selecting proportions of components used in a variety of mixtures. In general, high void content suggests that the material could be improved by providing additional fines in the fine aggregate or more cementitious material may be needed to fill voids between particles.

5.3.4 The bulk dry specific gravity of the fine aggregate is used in calculating the void content. The effectiveness of these test methods of determining void content and its relationship to particle shape and texture depends on the bulk specific gravity of the various size fractions being equal, or nearly so. The void content is actually a function of the volume of each size fraction. If the type of rock or minerals, or its porosity, in any of the size fractions varies markedly it may be necessary to

determine the specific gravity of the size fractions used in the test.

5.4 Void content information from Test Methods A, B, or C will be useful as an indicator of properties such as: the mixing water demand of hydraulic cement concrete; flowability, pumpability, or workability factors when formulating grouts or mortars; or, in bituminous concrete, the effect of the fine aggregate on stability and voids in the mineral aggregate; or the stability of the fine-aggregate portion of a base course aggregate.

6. Apparatus

6.1 *Cylindrical Measure*—A right cylinder of approximately 100-mL capacity having an inside diameter of approximately 39 mm and an inside height of approximately 86 mm made of drawn copper water tube meeting the requirements of Specification B 88, Type M or B 88M, Type C. The bottom of the measure shall be metal at least 6 mm thick, shall be firmly sealed to the tubing, and shall be provided with means for aligning the axis of the cylinder with that of the funnel. See Fig. 1.

6.2 *Funnel*—The lateral surface of the right frustum of a cone sloped $60 \pm 4^\circ$ from the horizontal with an opening of 12.7 ± 0.6 -mm diameter. The funnel section shall be a piece of metal, smooth on the inside and at least 38 mm high. It shall have a volume of at least 200 mL or shall be provided with a supplemental glass or metal container to provide the required volume. See Fig. 2.

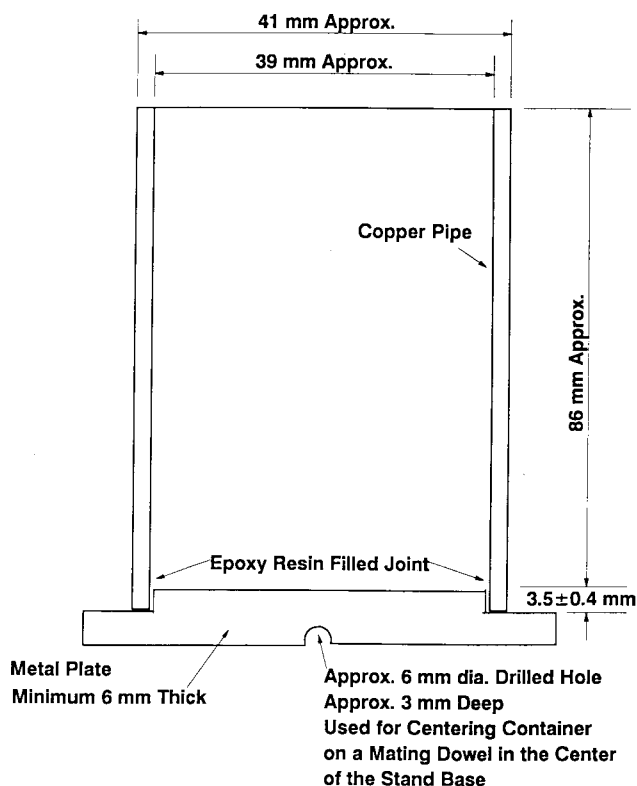
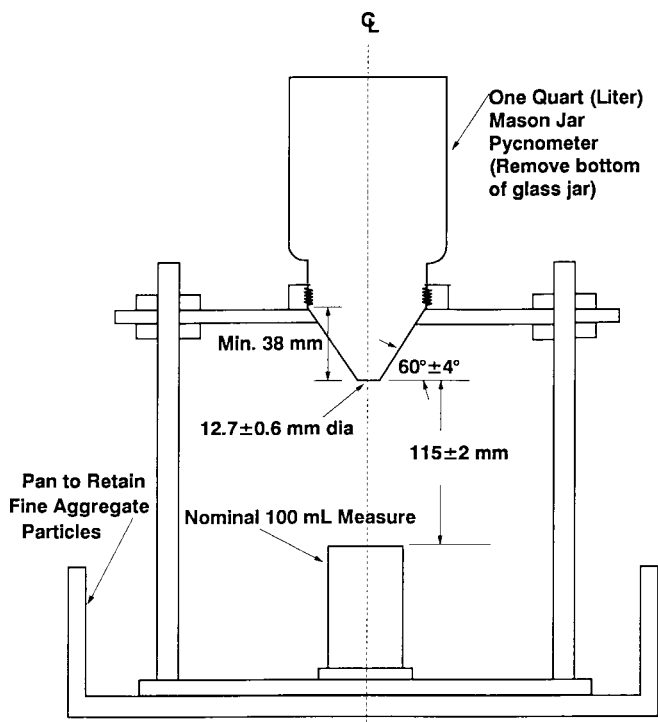

FIG. 1 Nominal 100-mL Cylindrical Measure



Section Through Center of Apparatus

FIG. 2 Suitable Funnel Stand Apparatus with Cylindrical Measure in Place

NOTE 1—Pycnometer top C9455⁷ is satisfactory for the funnel section, except that the size of the opening has to be enlarged and any burrs or lips that are apparent should be removed by light filing or sanding before use. This pycnometer top must be used with a suitable glass jar with the bottom removed (Fig. 2).

6.3 *Funnel Stand*—A three- or four-legged support capable of holding the funnel firmly in position with the axis of the funnel colinear (within a 4° angle and a displacement of 2 mm) with the axis of the cylindrical measure. The funnel opening shall be 115 ± 2 mm above the top of the cylinder. A suitable arrangement is shown in Fig. 2.

6.4 *Glass Plate*—A square glass plate approximately 60 by 60 mm with a minimum 4-mm thickness used to calibrate the cylindrical measure.

6.5 *Pan*—A metal or plastic pan of sufficient size to contain the funnel stand and to prevent loss of material. The purpose of the pan is to catch and retain fine aggregate particles that overflow the measure during filling and strike off.

6.6 *Metal Spatula*, with a blade approximately 100 mm long, and at least 20 mm wide, with straight edges. The end shall be cut at a right angle to the edges. The straight edge of the spatula blade is used to strike off the fine aggregate.

6.7 *Scale or Balance*, accurate and readable to ±0.1 g within the range of use, capable of weighing the cylindrical measure and its contents.

7. Sampling

7.1 Obtain the sample(s) used for this test in accordance

with Practices D 75 and Practice C 702, or from sieve analysis samples used for Test Method C 136, or from aggregate extracted from a bituminous concrete specimen. For Methods A and B, wash the sample over a 150-µm (No. 100) or 75-µm (No. 200) sieve in accordance with Test Method C 117 and then dry and sieve into separate size fractions in accordance with the procedures of Test Method C 136. Maintain the necessary size fractions obtained from one (or more) sieve analysis in a dry condition in separate containers for each size. For Method C, dry a split of the as-received sample in accordance with the drying procedure in Test Method C 136.

8. Calibration of Cylindrical Measure

8.1 Apply a light coat of grease to the top edge of the dry, empty cylindrical measure. Weigh the measure, grease, and glass plate. Fill the measure with freshly boiled, deionized water at a temperature of 18 to 24°C. Record the temperature of the water. Place the glass plate on the measure, being sure that no air bubbles remain. Dry the outer surfaces of the measure and determine the combined mass of measure, glass plate, grease, and water by weighing. Following the final weighing, remove the grease and determine the mass of the clean, dry, empty measure for subsequent tests.

8.2 Calculate the volume of the measure as follows:

$$V = \frac{1000 M}{D}$$

where:

V = volume of cylinder, mL,

M = net mass of water, g, and

D = density of water, kg/m³ (see table in Test Method C 29/C 29M for density at the temperature used.)

Determine the volume to the nearest 0.1 mL.

NOTE 2—If the volume of the measure is greater than 100.0 mL, it may be desirable to grind the upper edge of the cylinder until the volume is exactly 100.0 mL to simplify subsequent calculations.

9. Preparation of Test Samples

9.1 *Test Method A—Standard Graded Sample*—Weigh out and combine the following quantities of fine aggregate which have been dried and sieved in accordance with Test Method C 136.

Individual Size Fraction	Mass, g
2.36 mm (No. 8) to 1.18 mm (No. 16)	44
1.18 mm (No. 16) to 600 µm (No. 30)	57
600 µm (No. 30) to 300 µm (No. 50)	72
300 µm (No. 50) to 150 µm (No. 100)	17
	190

The tolerance on each of these amounts is ±0.2 g.

9.2 *Test Method B—Individual Size Fractions*—Prepare a separate 190-g sample of fine aggregate, dried and sieved in accordance with Test Method C 136, for each of the following size fractions:

Individual Size Fraction	Mass, g
2.36 mm (No. 8) to 1.18 mm (No. 16)	190
1.18 mm (No. 16) to 600 µm (No. 30)	190
600 µm (No. 30) to 300 µm (No. 50)	190

The tolerance on each of these amounts is ±1 g. Do not mix these samples together. Each size is tested separately.

9.3 *Test Method C—As Received Grading*—Pass the sample

⁷ Available from Hogentogler and Co., Inc., 9515 Gerwig, Columbia, MD 21045.

(dried in accordance with Test Method C 136) through a 4.75-mm (No. 4) sieve. Obtain a 190 ± 1 -g sample of the material passing the 4.75-mm (No. 4) sieve for test.

9.4 *Specific Gravity of Fine Aggregate*—If the bulk dry specific gravity of fine aggregate from the source is unknown, determine it on the minus 4.75-mm (No. 4) material in accordance with Test Method C 128. Use this value in subsequent calculations unless some size fractions differ by more than 0.05 from the specific gravity typical of the complete sample, in which case the specific gravity of the fraction (or fractions) being tested must be determined. An indicator of differences in specific gravity of various particle sizes is a comparison of specific gravities run on the fine aggregate in different gradings. Specific gravity can be run on gradings with and without specific size fractions of interest. If specific gravity differences exceed 0.05, determine the specific gravity of the individual 2.36-mm (No. 8) to 150- μ m (No. 100) sizes for use with Method A or the individual size fractions for use with Test Method B either by direct measurement or by calculation using the specific gravity data on gradings with and without the size fraction of interest. A difference in specific gravity of 0.05 will change the calculated void content about 1 %.

10. Procedure

10.1 Mix each test sample with the spatula until it appears to be homogeneous. Position the jar and funnel section in the stand and center the cylindrical measure as shown in Fig. 2. Use a finger to block the opening of the funnel. Pour the test sample into the funnel. Level the material in the funnel with the spatula. Remove the finger and allow the sample to fall freely into the cylindrical measure.

10.2 After the funnel empties, strike off excess heaped fine aggregate from the cylindrical measure by a single pass of the spatula with the width of the blade vertical using the straight part of its edge in light contact with the top of the measure. Until this operation is complete, exercise care to avoid vibration or any disturbance that could cause compaction of the fine aggregate in the cylindrical measure (Note 3). Brush adhering grains from the outside of the container and determine the mass of the cylindrical measure and contents to the nearest 0.1 g. Retain all fine aggregate particles for a second test run.

NOTE 3—After strike-off, the cylindrical measure may be tapped lightly to compact the sample to make it easier to transfer the container to the scale or balance without spilling any of the sample.

10.3 Recombine the sample from the retaining pan and cylindrical measure and repeat the procedure. Average the results of two runs. See Section 11.

10.4 Record the mass of the empty measure. Also, for each run, record the mass of the measure and fine aggregate.

11. Calculation

11.1 Calculate the uncompacted voids for each determination as follows:

$$U = \frac{V - (F/G)}{V} \times 100$$

where:

V = volume of cylindrical measure, mL,

F = net mass of fine aggregate in measure, g (gross mass minus the mass of the empty measure),

G = bulk dry specific gravity of fine aggregate, and

U = uncompacted voids in the material, %.

11.2 For the standard graded sample (Test Method A) calculate the average uncompacted voids for the two determinations and report the results as U_s .

11.3 For the individual size fractions (Test Method B) calculate as follows:

11.3.1 First, the average uncompacted voids for the determinations made on each of the three size-fraction samples:

U_1 = uncompacted voids, 2.36 mm (No. 8) to 1.18 mm (No. 16), %,

U_2 = uncompacted voids, 1.18 mm (No. 16) to 600 μ m (No. 30), %, and

U_3 = uncompacted voids, 600 μ m (No. 30) to 300 μ m (No. 50), %.

11.3.2 Second, the mean uncompacted voids (U_m) including the results for all three sizes:

$$U_m = (U_1 + U_2 + U_3)/3$$

11.4 For the as-received grading (Test Method C) calculate the average uncompacted voids for the two determinations and report the result as U_R .

12. Report

12.1 Report the following information for the standard graded sample (Test Method A):

12.1.1 Uncompacted voids (U_s), % to the nearest one tenth of a percent (0.1 %), and

12.1.2 Specific gravity value used in the calculations.

12.2 Report the following percent voids to the nearest one tenth of a percent (0.1 %) for the individual size fractions (Test Method B):

12.2.1 Uncompacted voids for size fractions: (a) 2.36 mm (No. 8) to 1.18 mm (No. 16) (U_1); (b) 1.18 mm (No. 16) to 600 μ m (No. 30) (U_2); and (c) 600 μ m (No. 30) to 300 μ m (No. 50) (U_3),

12.2.2 Mean uncompacted voids (U_m), and

12.2.3 Specific gravity value(s) used in the calculations, and whether the specific gravity value(s) were determined on a graded sample or the individual-sized fractions used in the test.

12.3 Report the following information for the as-received sample (Test Method C):

12.3.1 Uncompacted voids (U_R), % to the nearest one tenth of a percent (0.1 %).

12.3.2 Specific gravity value used in the calculation.

13. Precision and Bias

13.1 *Precision*—Criteria for judging the acceptability of test results obtained by this test method are given as follows:

NOTE 4—The figures in Column 2 are the standard deviations that have been found to be appropriate for the materials and conditions of test described in Column 1. The figures given in Column 3 are the limits that should not be exceeded by the difference between the results of two properly conducted tests.

Material and Type Index	Standard Deviation ^A	Acceptable Range of Two Results ^A
Single-operator precision:		
Graded standard sand ^B	0.13 %	0.37 %
Manufactured fine aggregate ^C	0.33 %	0.94 %
Multilaboratory precision:		

 **C 1252**

Graded standard sand ^B	0.33 %	0.93 %
Manufactured fine aggregate ^C	1.1 %	3.1 %

conducted in accordance with Method C—As Received Grading on a manufactured fine aggregate.

13.2 *Bias*—Since there is no accepted reference material suitable for determining the bias for the procedures in these test methods, bias has not been determined.

14. Keywords

14.1 angularity; fine aggregate; particle shape; sand; surface texture; void content

^A These numbers represent, respectively, the (1s) and (d2s) limits as described in Practice C 670.

^B These estimates of precision are based on “graded standard sand” as described in Specification C 778, which is considered rounded, and is graded from 600 µm (No. 30 sieve) to 150 µm (No. 100 sieve), and may not be typical of other fine aggregates.

^C These estimates of precision are based on results from the AASHTO Materials Reference Laboratory (AMRL) Proficiency Sample Program. The data are based on the analyses of 103 paired test results from 103 laboratories. The tests were

The American Society for Testing and Materials takes no position respecting the validity of any patent rights asserted in connection with any item mentioned in this standard. Users of this standard are expressly advised that determination of the validity of any such patent rights, and the risk of infringement of such rights, are entirely their own responsibility.

This standard is subject to revision at any time by the responsible technical committee and must be reviewed every five years and if not revised, either reapproved or withdrawn. Your comments are invited either for revision of this standard or for additional standards and should be addressed to ASTM Headquarters. Your comments will receive careful consideration at a meeting of the responsible technical committee, which you may attend. If you feel that your comments have not received a fair hearing you should make your views known to the ASTM Committee on Standards, at the address shown below.

This standard is copyrighted by ASTM, 100 Barr Harbor Drive, PO Box C700, West Conshohocken, PA 19428-2959, United States. Individual reprints (single or multiple copies) of this standard may be obtained by contacting ASTM at the above address or at 610-832-9585 (phone), 610-832-9555 (fax), or service@astm.org (e-mail); or through the ASTM website (www.astm.org).