



Designation: D 1079 – 04<sub>2</sub>

## Standard Terminology Relating to Roofing, Waterproofing, and Bituminous Materials<sup>1</sup>

This standard is issued under the fixed designation D 1079; the number immediately following the designation indicates the year of original adoption or, in the case of revision, the year of last revision. A number in parentheses indicates the year of last reapproval. A superscript epsilon ( $\epsilon$ ) indicates an editorial change since the last revision or reapproval.

### 1. Referenced Documents

#### 1.1 *ASTM Standards:*

C 33 Specification for Concrete Aggregates<sup>2</sup>

---

<sup>1</sup> This terminology is under the jurisdiction of ASTM Committee D08 on Roofing, Waterproofing, and Bituminous Materials and is the direct responsibility of Subcommittee D08.01 on Nomenclature, Definitions, and Editorial.

Current edition approved ~~Sept. 10, 2004~~<sup>2</sup>. Published ~~November 2004~~<sup>2</sup>. Originally published as D 1079 – 50 T. Last previous edition D 1079 – 00a<sub>1</sub>.

C 591 Specification for Unfaced Preformed Rigid Cellular Polyisocyanurate Thermal Insulation<sup>3</sup>

C 1289 Specification for Faced Rigid Cellular Polyisocyanurate Thermal Insulation Board<sup>3</sup>

D 312 Specification for Asphalt Used in Roofing<sup>4</sup>

D 450 Specification for Coal-Tar Pitch Used in Roofing, Dampproofing, and Waterproofing<sup>4</sup>

D 698 Test Method for Laboratory Compaction Characteristics of Soil Using Standard Effort (12; 400 ft-lbf/ft<sup>3</sup>(600 kN-m/m<sup>3</sup>))<sup>5</sup>

D 727 Test Method for Kerosine Number of Roofing and Flooring Felt by the Vacuum Method<sup>6</sup>

D 1557 Test Method for Laboratory Compaction Characteristics of Soil Using Modified Effort (56; 000 ft-lbf/ft<sup>3</sup>(2,700 kN-m/m<sup>3</sup>))<sup>5</sup>

D 2822 Specification for Asphalt Roof Cement<sup>4</sup>

D 4022 Specification for Coal Tar Roof Cement, Asbestos Containing<sup>4</sup>

D 4586 Specification for Asphalt Roof Cement, Asbestos-Free<sup>4</sup>

## 2. Terminology

### 2.1 Definitions:

**accelerated weathering**, *v*—the exposure of a specimen to a specified test environment for a specified time with the intent of producing, in a shorter time period, effects similar to actual weathering.

**aggregate**—(1) crushed stone, crushed slag, or water-worn gravel used for surfacing a built-up roof;

(2) any granular mineral material.

**alligatoring**—the cracking of the surfacing bitumen on a built-up roof, producing a pattern of cracks similar to an alligator's hide; the cracks may not extend through the surfacing bitumen.

**anionic emulsion**—an emulsion in which the emulsifying system establishes a predominance of negative charges on the discontinuous phase.

**application rate**—the quantity (mass, volume or thickness) of material applied per unit area.

**artificial weathering**, *v*—exposure to conditions, which may be cyclic, involving temperature, relative humidity, radiant energy, and/or any other conditions or pollutants found in the atmosphere in various geographical areas, which may accelerate changes in properties of materials over those of natural weather conditions.

**asbestos**—a group of natural fibrous impure silicate materials.

**asphalt**—a dark brown to black cementitious material in which the predominating constituents are bitumens which occur in nature or are obtained in petroleum processing.

**asphalt, air blown**—an asphalt produced by blowing air through molten asphalt at an elevated temperature to raise its softening point and modify other properties.

**asphaltene**—a high molecular weight hydrocarbon fraction precipitated from asphalt by a designated paraffinic naphtha solvent at a specified temperature and solvent-asphalt ratio.

DISCUSSION—The asphaltene fraction should be identified by the temperature and solvent-asphalt ratio used.

**asphalt felt**—an asphalt-saturated felt.

**asphalt, steam blown**—an asphalt produced by blowing steam through molten asphalt to modify its properties.

**asphaltite**—a natural asphalt found below ground level.

**asphalt mastic**—a mixture of asphaltic material and graded mineral aggregate that can be poured when heated, but requires mechanical manipulation to apply.

**asphalt rock (rock asphalt)**—a naturally occurring rock formation, usually limestone or sandstone, containing throughout its mass a minor amount of asphalt.

**asphalt roof cement, n**—a trowelable mixture of asphalt, solvents, mineral stabilizers, fillers or fibers, or both. See Specifications D 2822 and D 4586.

**asphalt roof cement, n**—see *flashing cement*.

**backnailing**—the practice of blind-nailing roofing felts to a substrate in addition to hot-mopping to prevent slippage.

**bald roof**—See **smooth-surfaced roof**.

**base ply**—the bottom or first ply in a built-up roofing membrane when additional plies are to be subsequently installed.

**base sheet**—a product intended to be used as a base ply in a built-up roofing system.

**bitumen**—(1) a class of amorphous, black or dark-colored, (solid, semi-solid, or viscous) cementitious substances, natural or manufactured, composed principally of high molecular weight hydrocarbons, soluble in carbon disulfide, and found in asphalts, tars, pitches, and asphaltites;

(2) a generic term used to denote any material composed principally of bitumen.

<sup>2</sup> Annual Book of ASTM Standards, Vol 04.02.

<sup>3</sup> Annual Book of ASTM Standards, Vol 04.06.

<sup>4</sup> Annual Book of ASTM Standards, Vol 04.04.

<sup>5</sup> Annual Book of ASTM Standards, Vol 04.08.

<sup>6</sup> Annual Book of ASTM Standards, Vol 15.09.

*bitumen trap*—See **pitch pocket**.

**bituminized**, *adj*—impregnated with bitumen. Example: bituminized fiber pipe.

**bituminous**, *adj*—containing or treated with bitumen. Examples: bituminous concrete, bituminous felts and fabrics, bituminous pavement.

**bituminous emulsion**—(1) a suspension of minute globules of bituminous material in water or in an aqueous solution;

(2) a suspension of minute globules of water or of an aqueous solution in a liquid bituminous material (invert emulsion).

**bituminous grout**—a mixture of bituminous material and fine sand that will flow into place without mechanical manipulation when heated.

**blast-furnace slag**—the nonmetallic product, consisting essentially of silicates and alumino-silicates of calcium and other bases, that is developed in a molten condition simultaneously with iron in a blast furnace.

**blind nailing**—the use of nails that are not exposed to the weather in the finished roofing.

**blister**—(1) a raised portion of a roofing membrane resulting from local internal pressure;

(2) the similarly formed protuberances in coated prepared roofing.

**blocking**—(1) wood built into a roofing system above the deck and below the membrane and flashing to (a) stiffen the deck around an opening, (b) act as a stop for insulation, (c) serve as a nailer for attachment of the membrane or flashing.

(2) wood cross-members installed between rafters or joists to provide support at cross-joints between deck panels.

(3) cohesion or adhesion between similar or dissimilar materials in roll or sheet form that may interfere with the satisfactory and efficient use of the material.

*blueberry*—See **strawberry**.

**bond**—the adhesive and cohesive forces holding two roofing components in intimate contact.

**brooming**—embedding a ply by using a broom to smooth it out and ensure contact with the adhesive under the ply.

**built-up roofing**—a continuous, semiflexible membrane consisting of plies of saturated felts, coated felts, fabrics or mats assembled in place with alternate layers of bitumen, and surfaced with mineral aggregate, bituminous materials, or a granule surfaced sheet (abbreviation, BUR).

**cant strip**—a beveled strip used under flashings to modify the angle at the point where the roofing or waterproofing membrane meets any vertical element.

*cap flashing*—See **flashing**.

**cap sheet**—a granule-surfaced coated felt used as the top ply of a built-up roofing membrane.

**cationic emulsion**—an emulsion in which the emulsifying system establishes a predominance of positive charges on the discontinuous phase.

**caulking**—a composition of vehicle and pigment, used at ambient temperatures for filling joints, that remains plastic for an extended time after application.

*channel mopping*—See **mopping**, (3) *strip*.

**coal tar**—a dark brown to black cementitious material produced by the destructive distillation of coal.

**coal tar roof cement**, *n*—a trowelable mixture of processed coal tar base, solvents, mineral fillers or fibers, or both. See Specification D 4022.

**coal-tar felt**—a felt that has been saturated with refined coal tar.

**coal-tar pitch**—a dark brown to black, solid cementitious material obtained as residue in the partial evaporation or distillation of coal tar.

**coated sheet (or felt)**—(1) an asphalt felt that has been coated on both sides with harder, more viscous asphalt;

(2) a glass fiber felt that has been simultaneously impregnated and coated with asphalt on both sides.

*coke-oven tar*—See **coal tar**.

**cold-process roofing**—a continuous, semiflexible membrane consisting of plies of felts, mats, or fabrics laminated on a roof with alternate layers of roof cement and surfaced with a cold-applied coating.

**concealed membrane waterproofing**, *n*—also referred to as **structural slab waterproofing**; (1) for below grade: refers to a form of waterproofing where the membrane is applied to the mud mat and later covered with a topping, usually concrete, to act as a wearing layer or course, and (2) for elevated structural concrete deck: applied over the structural surface and covered/concealed by other components such as a topping slab, pavers, ballast, pavement, and plantings.

**condensation**—the conversion of water vapor or other gas to liquid as the temperature drops or atmospheric pressures rises. (See also **dew point**).

**conditioning**, *v*—the storage of a specimen under specified temperature, humidity, etc., for a specified time prior to testing.

**conductance, thermal**—the thermal transmission in unit time through unit area of a particular body or assembly having defined surfaces, when unit average temperature difference is established between the surfaces.  $C = W/m^2 \cdot K$  ( $C = \text{Btu}/\text{h} \cdot \text{ft}^2 \cdot ^\circ\text{F}$ ).

**conductivity, thermal**—the thermal transmission, by conduction only, in unit time through unit area between two isothermal surfaces of an infinite slab of a homogeneous material of unit thickness, in a direction perpendicular to the surface, when unit temperature difference is established between the surfaces.  $k = W/m \cdot K$  ( $k = \text{Btu} \cdot \text{in.}/\text{h} \cdot \text{ft}^2 \cdot ^\circ\text{F}$ ).

*cone penetration*—See **penetration**.

**coping**—a covering on top of a wall exposed to the weather, usually sloped to carry off water.

**counterflashing**—formed metal or elastomeric sheeting secured on or into a wall, curb, pipe, roof-top unit, or other surface, to cover and protect the upper edge of a base flashing and its associated fasteners.

**coverage**—the surface area to be continuously covered by a specific quantity of a particular material.

**creep**—the time-dependent part of a strain resulting from stress.

**cricket, n**—a construction to divert water around or away from a chimney, curb, wall, expansion joint, or other penetration. (See **saddle**).

**crushed stone**—the product resulting from the artificial crushing of rocks, boulders, or large cobblestones, substantially all faces of which have resulted from the crushing operation.

**cutback**—solvent-thinned bitumen used in cold-process roofing adhesives, flashing cements, and roof coatings.

**cutoff**—a detail designed to prevent lateral water movement into the insulation where the membrane terminates at the end of a day's work, or used to isolate sections of the roofing system. It is usually removed before the continuation of the work.

**dampproofing**—treatment of a surface or structure to resist the passage of water in the absence of hydrostatic pressure.

**dead level**—absolutely horizontal, or zero slope (see also **slope**).

**dead level asphalt**—a roofing asphalt conforming to the requirements of Specification D 312, Type I.

**dead level roofing**—a roofing system applied on a surface with a 0 to 2 % incline.

**deck**—the structural surface to which the roofing or waterproofing system (including insulation) is applied.

**direction change**—a change in the orientation of the principal dimension or of the support of adjoining units of the roofing system.

**double pour**—to apply two layers of aggregate and bitumen to a built-up roof.

**dry felt**—(1) see felt;

(2) a felt which has not been saturated with bitumen.

**edge stripping**—application of felt strips cut to narrower widths than the normal felt-roll width to cover a joint between flashing and built-up roofing.

**edge venting**—the practice of providing regularly spaced protected openings at a roof perimeter to relieve water vapor pressure in the insulation.

**elastomer**—a macromolecular material that returns rapidly to its approximate initial dimensions and shape after substantial deformation by a weak stress and subsequent release of that stress.

**embedment**—(1) the process of pressing a felt, aggregate, fabric, mat, or panel uniformly and completely into hot bitumen or adhesive to ensure intimate contact at all points;

(2) the process of pressing granules into coating in the manufacture of factory-prepared roofing, such as shingles.

**emulsion**—an intimate mixture of bitumen and water, with uniform dispersion of the bitumen or water globules, usually stabilized by an emulsifying agent or system.

**envelope**—a continuous membrane edge seal formed at the perimeter and at penetrations by folding the base sheet or ply over the plies above and securing it to the top of the membrane. The envelope prevents bitumen seepage from the edge of the membrane.

**equilibrium moisture content**—(1) the moisture content of a material stabilized at a given temperature and relative humidity, expressed as percent moisture by weight;

(2) the typical moisture content of a material in any given geographical area.

**equiviscous temperature (EVT), n**—the temperature at which a bitumen attains the proper viscosity for built-up membrane application. EVT may or may not be applicable to polymer modified bituminous sheet materials. (See **EVT for asphalt** and **EVT for coal tar pitch**).

DISCUSSION—In England, EVT is the temperature corresponding to a standard efflux time from a road tar viscometer.

**equiviscous temperature for asphalt, n**—the equiviscous temperature (EVT) for roofing asphalt (Specification D 312, Type I, II, III, or IV) is as follows: (1) *mop application*—the temperature at which the asphalt's apparent viscosity is 125 cP. (2) *mechanical spreader application*—the temperature at which the asphalt's apparent viscosity is 75 cP. See **equiviscous temperature** and **EVT application range**.

**equiviscous temperature for coal tar**—the equiviscous temperature (EVT) for roofing coal tar (Specification D 450, Type I or III) is the temperature at which the coal tar's apparent viscosity is 25 cP. See **equiviscous temperature** and **EVT application range**.

**EVT application range, n**—the bitumen application temperature range. The range is from 25°F below the EVT to 25°F above the EVT (50°F span). The temperature is measured in the mop cart or mechanical spreader just prior to the application of bitumen to the substrate.

**expansion joint**—a structural separation between two building elements that allows free movement between the elements without damage to the roofing or waterproofing system.

**exposure**—(1) the transverse dimension of a roofing element not overlapped by an adjacent element in any roofing system. The exposure of any ply in a membrane may be computed by dividing the felt width minus 51 mm (2 in.), by the number of shingled plies; thus, the exposure of a 914-mm (36-in.) wide felt in a shingled, four-ply membrane should be 216 mm (8½ in.);

(2) the time during which a portion of a roofing element is exposed to the weather.

*extra-steep asphalt*— See **super-steep asphalt**.

**fabric, n**—a woven or nonwoven cloth of organic or inorganic filaments, threads, or yarns.

**facer**, *n*—the outermost, adhered top or bottom, or both, sheet (or layer) of an insulation board that is comprised of a different material than the insulation itself. It is commonly composed of organic paper, glass mat, or a combination thereof, generally impregnated or coated, or both, with asphalt, latex, or the like; or metal foil.

**factory square**—10 m<sup>2</sup>(108 ft<sup>2</sup>).

**fallback**—a reduction in bitumen softening point, sometimes caused by refluxing or overheating in a relatively closed container. (See also **softening point drift**).

**felt**—a flexible sheet manufactured by the interlocking of fibers with a binder or through a combination of mechanical work, moisture, and heat. Felts are manufactured principally from vegetable fibers (organic felts), asbestos fibers (asbestos felts) or glass fibers (glass fiber felts); other fibers may be present in each type.

**felt layer**—(1) a machine used for applying bitumen and built-up roofing felts;  
(2) See **ply**.

**felt mill ream**—the mass in pounds of 480 ft<sup>2</sup> of dry, unsaturated felt, also termed “point weight.”

**fine mineral surfacing**—water-insoluble inorganic material, more than 50 % of which passes the 500- $\mu$ m (No. 35) sieve, used on the surface of roofing.

**finger blisters**—finger shaped blisters or wrinkles in the plies of a built-up roofing or waterproofing membrane.

*finger wrinkles*—See **finger blisters**.

**fishmouth**—(1) a half-cylindrical or half-conical opening formed by an edge wrinkle or failure to embed a roofing felt;  
(2) *in shingles*, a half-conical opening formed at a cut edge.

**flashing**—the system used to seal membrane edges at walls, expansion joints, drains, gravel stops, and other places where the membrane is interrupted or terminated. Base flashing covers the edges of the membrane. Cap or counterflashing shields the upper edges of the base flashing.

**flashing cement**—a trowelable mixture of cutback bitumen and mineral stabilizers including asbestos or other inorganic fibers.

**flat asphalt**—a roofing asphalt conforming to the requirements of Specification D 312, Type II.

**flood coat**—the top layer of bitumen used to hold the aggregate on an aggregate-surfaced, built-up roofing membrane.

**fluid-applied elastomer**—an elastomeric material, fluid at ambient temperature, that dries or cures after application to form a continuous membrane. Such systems normally do not incorporate reinforcement.

**flux**—a bituminous material used as a feed stock for further processing and as a material to soften other bituminous materials.

**“free carbon” in tars**—the hydrocarbon fraction that is precipitated from a tar by dilution with carbon disulfide.

**glass felt**—glass fibers bonded into a sheet with resin and suitable for impregnation in the manufacture of bituminous waterproofing, roofing membranes, and shingles.

**glass mat**—a thin mat of glass fibers with or without a binder.

**glaze coat**—(1) the top layer of asphalt in a smooth-surfaced built-up roof assembly;

(2) a thin protective coating of bitumen applied to the lower plies or top ply of a built-up membrane, when application of additional felts, or the flood coat and aggregate surfacing are delayed.

*granule*—See **mineral granules**.

**gravel**—coarse, granular aggregate, with pieces larger than sand grains, resulting from the natural erosion of rock.

**gravel in**—to spread aggregate into hot bitumen on the surface of the roofing membrane.

**gravel stop**—a flanged device, frequently metallic, designed to prevent loose aggregate from washing off the roof and to provide a continuous finished edge for the roofing.

**headlap**—the minimum distance, measured at 90 deg to the eave along the face of a shingle or felt as applied to a roof, from the upper edge of the shingle or felt, to the nearest exposed surface.

**heat exposure**, *v*— the process of subjecting a specimen to an elevated temperature at atmospheric pressure for a specified period of time with the intent of determining properties by subsequent testing.

**holiday**—an area where a liquid-applied material is missing.

**“hot stuff” or “hot”**—a roofer’s term for hot bitumen.

**hydrokinetic roof system**, *n*—a roof system that depends on quick drainage via water shedding to prevent water entry into or through the system.

**hydrostatic roof system**, *n*—a roof system that is capable of holding water without allowing water to penetrate the system.

**hygroscopic**—attracting, absorbing, and retaining atmospheric moisture.

**ice dam**—a mass of ice formed at the transition from a warm to a cold roof surface. Frequently formed by refreezing meltwater at the overhang of a steep roof, an ice dam may cause ice and water to back up under shingles or other roofing materials.

**impregnate**, *v*— in roofing materials manufacture, to completely surround the fibers in a felt or mat with bitumen, with the spaces between the fibers partially or completely filled without a continuous coating of bitumen on the surface.

**incline**—the slope of a roof expressed in percent or in the number of vertical units of rise per horizontal unit of run.

**inorganic**, *adj*— being or composed of matter other than hydrocarbons and their derivatives, or matter that is not of plant or animal origin.

*iso*—in roofing, see **polyisocyanurate foam board**.

*isoboard*—See **polyisocyanurate foam board**.

*insulation*—See **thermal insulation**.

**kerosine number**—the millilitres of kerosine held per 100 g of felt as determined by Test Method D 727. To obtain the percentage saturating capacity of the felt for any bituminous saturant, obtain the specific gravity of the saturant and multiply that figure by the kerosine number of the felt.

**knot**—an imperfection or nonhomogeneity in materials used in fabric construction, the presence of which causes surface irregularities.

**liquid bituminous material**—one having a definite volume but no definite form, except as provided by its container. It has a viscosity of 0.1 to  $1 \times 10^5$  cSt ( $\text{mm}^2/\text{s}$ ) at 40°C. This does not include powders or granular materials.

**loose-laid membrane**—a ballasted roofing membrane that is attached to the substrate only at the edges and penetrations through the roof.

**lot**—in roofing, (1) production lot—all material produced in one eight-hour shift of the same type (and color when applicable); (2) *delivery lot*—all material of the same type delivered at one time by one truck or railroad car.

**low slope**, *adj*—in roofing, that which commonly describes an incline of a roof which is 14° (25 % or 3 in./ft) or less.

*mastic*—See **flashing cement** and **asphalt mastic**.

**membrane**—a flexible or semiflexible roof covering or waterproofing, whose primary function is the exclusion of water.

**mesh**—the square opening of a sieve.

**metal flashing**—See **flashing**; frequently used as through-wall, cap-, or counter-flashing.

**mineral fiber felt**—a felt with rock wool as the principal component.

**mineral granules**—opaque, natural, or synthetically colored aggregate commonly used to surface cap sheets, granule-surfaced sheets, and roofing shingles.

**mineral stabilizer**—a fine, water-insoluble inorganic material, used in admixture with solid or semisolid bituminous materials.

**mineral-surfaced roofing**—built-up roofing whose top ply consists of a granule-surfaced sheet.

**mineral-surfaced sheet**—a felt that is coated on one or both sides with asphalt and surfaced with mineral granules.

**mole run**—a meandering ridge in a membrane not associated with insulation or deck joints.

**mop-and-flop**—a procedure in which roofing elements (insulation boards, felt plies, cap sheets, and so forth) are initially placed upside down adjacent to their ultimate locations, are coated with adhesive, and are then turned over and adhered to the substrate.

**mopping**—the application of hot bitumen with a mop or mechanical applicator to the substrate or to the plies of a built-up roof. There are four types of mopping: (1) *solid*—a continuous coating; (2) *spot*—bitumen is applied in roughly circular areas, generally about 460 mm (18 in.) in diameter, leaving a grid of unmopped, perpendicular areas; (3) *strip*—bitumen is applied in parallel bands, generally 200 mm (8 in.) wide and 300 mm (12 in.) apart; (4) *sprinkle*—bitumen is shaken onto the substrate from a broom or mop in a random pattern.

**mud cracking**—surface cracking resembling a dried mud flat.

**mud mat**, *n*—in construction design: (1) a surfacing layer suitable for the application of membrane waterproofing, installed on a prepared subgrade; (2) an area of fill compacted to no less than 95 % of the maximum dry density of the fill based upon the appropriate laboratory compaction test, such as defined in Test Methods D 698 or D 1557.

**mud slab**, *n*—a 2 in. (50 mm) minimum thickness non-reinforced concrete slab suitable as the substrate for membrane waterproofing.

**nailing**—(1) exposed-nailing of roofing wherein nail heads are bare to the weather;

(2) concealed-nailing of roofing wherein nail heads are concealed from the weather. (See also **blind nailing**).

**negative side waterproofing**, *n*—an application wherein the waterproofing system and the source of hydrostatic pressure are on opposite sides of the structural element.

**neoprene**—a synthetic rubber (polychloroprene) used in liquid- or sheet-applied elastomeric roofing membranes or flashing.

**nineteen-inch selvage**—a prepared roofing sheet with a 432-mm (17-in.) granule-surfaced exposure and a 483-mm (19-in.) selvage.

**ninety-pound**—a prepared roll roofing with a granule-surfaced exposure that has a mass of approximately 4400 g/m<sup>2</sup> (90 lb/108 ft<sup>2</sup>).

**one-on-one**—the application of a single ply of roofing over the substrate, followed by the application of a second single ply over the first (phased application).

**organic**, *adj*—being or composed of hydrocarbons or their derivatives, or matter of plant or animal origin.

**parting agent**—a material applied to one or both surfaces of a sheet to prevent blocking.

**pea gravel**, *n*—in roofing, small, natural aggregate, 6 to 10 mm ( $\frac{1}{4}$  to  $\frac{3}{8}$  in.) in diameter, screened to comply with Specification C 33, size 8.

**peak**, *n*—in constant rate of elongation load-strain testing, the point of maximum load.

**penetration**—the consistency of a bituminous material expressed as the distance in tenths of a millimetre (0.1 mm) that a standard needle penetrates vertically a sample of material under specified conditions of loading, time, and temperature. A cone is sometimes used for special purposes instead of a needle.

**perlite**—an aggregate used in lightweight insulating concrete and in preformed perlite insulating board; formed by heating and expanding siliceous volcanic glass.

**permeance**—the rate of water vapor transmission per unit area at a steady state through a membrane or assembly, expressed in  $\text{ng/Pa}\cdot\text{s}\cdot\text{m}^2$  ( $\text{grain/ft}^2\cdot\text{h}\cdot\text{in. Hg}$ ).

**phased application**—the installation of a roofing or waterproofing system during two or more separate time intervals; a roofing system not installed in a continuous operation.

**petroleum pitch**—a dark brown to black, predominantly aromatic, solid cementitious material obtained by the processing of petroleum, petroleum fractions, or petroleum residuals.

**picture framing**—a rectangular pattern of ridges in a membrane over insulation or deck joints.

**pinhole**—a tiny hole in a film, foil, or laminate comparable in size to one made by a pin.

*pitch*—See **incline**; **coal-tar pitch**; or **petroleum pitch**.

**pitch pocket**—a flanged, open-bottomed metal container placed around a column or other roof-penetration, and filled with hot bitumen or flashing cement to seal the joint.

*plastic cement*—See **flashing cement**.

**ply**—a layer of felt in a built-up roofing membrane; a four-ply membrane has at least four plies of felt at any vertical cross section cut through the membrane.

**plying cement**—any bituminous material used for adhering layers of felts, fabrics, or mats to structural surfaces and to each other.

*point weight*—See **felt mill ream**.

**polyisocyanurate foam, n**—a cellular thermal insulation produced by the polymerization of polyisocyanates in the presence of polyhydroxyl compounds, catalysts, cell stabilizers, and blowing agents. See Specification C 591.

**polyisocyanurate foam board, n**—a thermal insulation composed of polyisocyanurate foam with adhered facers. Commonly called *iso* or *isoboard*. See Specification C 1289.

**pond**—a surface which is incompletely drained.

**positive side waterproofing, n**—an application wherein the waterproofing system and the source of hydrostatic pressure are on the same side of the structural element.

**primer**—a thin liquid bitumen applied to a surface to improve the adhesion of heavier applications of bitumen and to absorb dust.

**rake**—the sloped edge of a roof at the first or last rafter.

*raspberry*—See **strawberry**.

**recovering**—the process of covering an existing roofing system with a new roofing system.

**reentrant corner**—an inside corner of a surface, producing stress concentrations in the roofing or waterproofing membrane.

**reglet**—a groove in a wall or other surface adjoining a roof surface for the attachment of counterflashing.

**reinforced membrane**—a roofing or waterproofing membrane reinforced with felts, mats, fabrics, or chopped fibers.

**relative humidity**—the ratio of the mass per unit volume (or partial pressure) of water vapor in an air-vapor mixture to the saturated mass per unit volume (or partial pressure) of the water vapor at the same temperature, expressed as a percentage.

*release agent*—See **parting agent**.

**reroofing**—the process of recovering or replacing an existing roofing system. See **recovering**.

**resistance, thermal**—the average temperature difference between two defined surfaces of a particular body or assembly when unit thermal transmission in unit time through unit area is established between the surfaces.  $R = K\cdot m^2/W$  ( $R = \text{°F}\cdot\text{h}\cdot\text{ft}^2/\text{Btu}$ ).

**ridging**—an upward, tenting displacement of a membrane, frequently over an insulation joint.

**roll roofing**—coated felts, either smooth or mineral-surfaced.

*roof cement*—See **flashing cement**.

**roofing system**—an assembly of interacting components designed to weatherproof, and normally to insulate, a building's top surface.

**rubber**—a material that is capable of recovering from large deformations quickly and forcibly, and can be, or already is, modified to a state in which it is essentially insoluble (but can swell) in boiling solvent such as benzene, methyl ethyl ketone, and ethanol-toluene azeotrope.

**DISCUSSION**—A rubber in its modified state, free of diluents, retracts within 1 min to less than 1.5 times its original length after being stretched at room temperature (18 to 29°C) to twice its length and held for 1 min before release.

**saddle, n**—a construction to channel or direct surface water to drains or off the roof. A saddle may be located between drains or in a valley, and is often like a small hip roof or a pyramid with a diamond-shaped base. (See **cricket** ).

**sales square**—the quantity of prepared roofing required to cover  $9.3 \text{ m}^2$  ( $100 \text{ ft}^2$ ) of deck.

**saturated felt**—a felt that has been immersed in hot bitumen; the felt adsorbs and absorbs as much bitumen as it can retain under the processing conditions, but remains porous and contains voids.

**screen**—an apparatus with circular apertures for separating sizes of material.

**scrim, n**—lightweight woven or non-woven fabrics that are manufactured from yarns.

**scuttle**—a hatch that provides access to the roof from the interior of the building.

**sealant**—a mixture of polymers, fillers, and pigments used to fill and seal joints where moderate movement is expected; unlike caulking, it cures to a resilient solid.

**selvage**—an edge or edging which differs from the main part of: (1) a fabric; or (2) granule-surfaced roll roofing.

**shark fin**—an upward-curved felt sidelap or endlap.

- shingle**—(1) a small unit of prepared roofing designed for installation with similar units in overlapping rows on inclines normally exceeding 25 %;
- (2) to cover with shingles; and
- (3) to apply any sheet material in overlapping rows like shingles.
- shingling**—(1) the procedure of laying parallel felts so that one longitudinal edge of each felt overlaps, and the other longitudinal edge underlaps, an adjacent felt. (See also **ply**). Normally, felts are shingled on a slope so that the water flows over rather than against each lap;
- (2) the application of shingles to a sloped roof.
- sieve**—an apparatus with square apertures for separating sizes of material.
- skater's cracks**—curvilinear cracks in a roofing membrane that appear to relate neither to the direction of application of the membrane components nor the substrate components.
- slag**—the fused agglomerate which separates in metal smelting and floats on the surface of the molten metal. (See also **blast-furnace slag**.)
- slippage**—relative lateral movement of adjacent components of a built-up membrane. It occurs mainly in roofing membranes on a slope, sometimes exposing the lower plies or even the base sheet to the weather.
- slope**—the tangent of the angle between the roof surface and the horizontal plane, expressed as a percentage, or in inches of rise per foot of horizontal distance. (See also **incline**).
- smooth-surfaced roof**—a built-up roof without mineral aggregate surfacing.
- softening point**—the temperature at which a bitumen becomes soft enough to flow as determined by an arbitrary, closely defined method.
- softening point drift**—a change in the softening point during storage or application. (See also **fallback** ).
- solid bituminous material**—one having a viscosity of over  $1 \times 10^5$  cSt (mm<sup>2</sup>/s) at 40°C or an equivalent viscosity at an agreed-upon temperature. This includes powders and granular materials.
- solid mopping*—See **mopping**.
- split**—a membrane tear resulting from tensile stress.
- split sheet*—See **nineteen-inch selvage**.
- spot mopping*—See **mopping**.
- sprinkle mopping*—See **mopping**.
- spud**—to remove the roofing aggregate and most of the bituminous top coating by scraping and chipping.
- square**—a roof area of 9.29 m<sup>2</sup> (100 ft<sup>2</sup>), or enough material to cover 9.29 m<sup>2</sup> of deck.
- stack vent**—a vertical outlet in a built-up roofing system to relieve the pressure exerted by water vapor between the roofing membrane and the vapor retarder or deck.
- steep asphalt**—a roofing asphalt conforming to the requirements of Specification D 312, Type III.
- steep slope**, *adj*—in roofing, that which commonly describes an incline of a roof which is greater than 14° (25 % or 3 in./ft).
- strawberry**—a small bubble or blister in the flood coating of a gravel-surfaced membrane.
- strip mopping*—See **mopping**.
- stripping**—strip flashing:
- (1) the technique of sealing a joint between metal and built-up membrane with one or two plies of felt or fabric and hot- or cold-applied bitumen;
- (2) the technique of taping joints between insulation boards or deck panels.
- substrate**—the surface upon which the roofing or waterproofing membrane is placed (structural deck or insulation).
- sump**—a depression around a drain.
- super-steep asphalt**—a roofing asphalt conforming to the requirements of Specification D 312, Type IV.
- susceptibility**—when not otherwise qualified, the degree of change in viscosity with temperature.
- system*—See **roofing system**.
- tapered edge strip**—a tapered insulation strip used to elevate the roofing at the perimeter and at penetrations of the roof.
- tar**—a brown or black bituminous material, liquid or semisolid in consistency, in which the predominating constituents are bitumens obtained as condensates in the processing of coal, petroleum, oil-shale, wood, or other organic materials.
- tear off**—to remove an existing roofing system down to the structural deck.
- thermal insulation**—a material applied to reduce the flow of heat.
- thermal shock**—the stress-producing phenomenon resulting from sudden temperature drops in a roof membrane when, for example, a rain shower follows brilliant sunshine.
- through-wall flashing**—a water-resistant membrane or material assembly extending totally through a wall and its cavities, positioned to direct any water within the wall to the exterior.
- tie-off**, *n*—in waterproofing, the transitional seal used to terminate a waterproofing application at the top or bottom of flashing or by forming a watertight seal with the substrate, membrane, or waterproofing system(s).
- t-joint**, *n*—the condition created by the overlapping intersection of three or four sheets in the membrane. See Fig. 1.
- vapor barrier**—See **vapor retarder**.

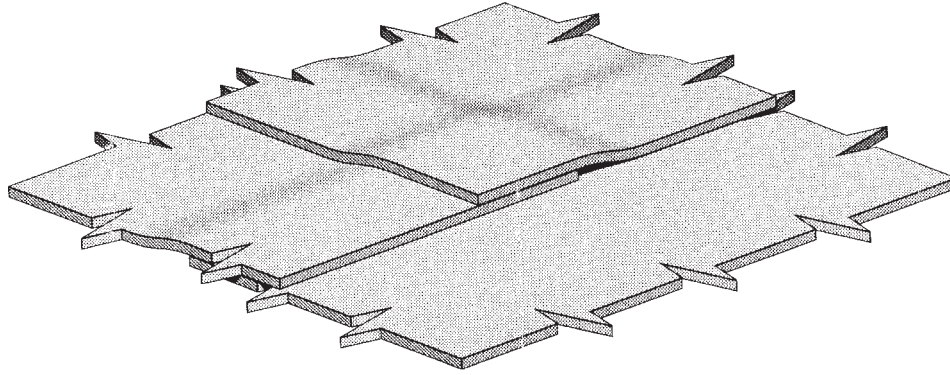

FIG. 1 T-Joint

**vapor migration**—the movement of water vapor from a region of high vapor pressure to a region of lower vapor pressure.

**vapor retarder**—a layer of material or a laminate used to appreciably reduce the flow of water vapor into the roofing system.

**vent**—an opening designed to convey water vapor or other gas from inside a building or a building component to the atmosphere.

**vermiculite**—an aggregate used in lightweight insulating concrete, formed by heating and expanding a micaceous mineral.

**viscoelasticity**—a combination of viscous and elastic properties in a material, with the relative contribution of each dependent upon time, temperature, stress, and strain rate.

**walk in**—to embed insulation panels in hot bitumen or adhesive by walking on them immediately after application.

**water repellent system, n**—an exterior coating system for above grade concrete or masonry which temporarily repels water but which is not intended to prevent the passage of moisture under hydrostatic pressure.

(1) *film forming type*—latex or oil based paints or similar materials that may require repair or renewal because of climatic action;

(2) *pore penetrating type*—types that fill or coat the interior of the surface pores of concrete or masonry and are temporarily retained in these surface pores thus providing water repelling action; periodic repair or renewal may be required because of climatic action.

**waterproofing**—treatment of a surface or structure to prevent the passage of water under hydrostatic pressure.

*This standard is subject to revision at any time by the responsible technical committee and must be reviewed every five years and if not revised, either reapproved or withdrawn. Your comments are invited either for revision of this standard or for additional standards and should be addressed to ASTM International Headquarters. Your comments will receive careful consideration at a meeting of the responsible technical committee, which you may attend. If you feel that your comments have not received a fair hearing you should make your views known to the ASTM Committee on Standards, at the address shown below.*

*This standard is copyrighted by ASTM International, 100 Barr Harbor Drive, PO Box C700, West Conshohocken, PA 19428-2959, United States. Individual reprints (single or multiple copies) of this standard may be obtained by contacting ASTM at the above address or at 610-832-9585 (phone), 610-832-9555 (fax), or service@astm.org (e-mail); or through the ASTM website (www.astm.org).*