



Designation: D 4989 – 90a (Reapproved 1999)<sup>e1</sup>

## Standard Test Method for the Apparent Viscosity (Flow) of Roofing Bitumens Using the Parallel Plate Plastometer<sup>1</sup>

This standard is issued under the fixed designation D 4989; the number immediately following the designation indicates the year of original adoption or, in the case of revision, the year of last revision. A number in parentheses indicates the year of last reapproval. A superscript epsilon ( $\epsilon$ ) indicates an editorial change since the last revision or reapproval.

<sup>e1</sup> NOTE—Editorially switched from English dominant to SI dominant.

### 1. Scope

1.1 This test method covers the measurement of apparent viscosity of roofing bitumen by means of a parallel plate plastometer. This test method is applicable for a viscosity range from  $10^2$  to  $10^9$  Pa·s ( $10^3$  to  $10^{10}$  poises). See Note 1.

NOTE 1—This relatively simple test method of measuring viscosity uses pre-determined arbitrary shear stress levels. Since roofing bitumens are non-Newtonian other viscosity test methods may give different results.

1.2 The values stated in SI units are regarded as standard. The inch-pound units given in parentheses are for information only.

1.3 *This standard does not purport to address all of the safety concerns, if any, associated with its use. It is the responsibility of the user of this standard to establish appropriate safety and health practices and determine the applicability of regulatory limitations prior to use.*

### 2. Referenced Documents

#### 2.1 ASTM Standards:

- D 140 Practice for Sampling Bituminous Materials<sup>2</sup>
- D 312 Specification for Asphalt Used in Roofing<sup>3</sup>
- D 450 Specification for Coal-Tar Pitch Used in Roofing, Dampproofing and Waterproofing<sup>3</sup>
- D 2171 Test Method for Viscosity of Asphalts by Vacuum Capillary Viscometer<sup>2</sup>
- D 3205 Test Method for Viscosity of Asphalt with Cone and Plate Viscometer<sup>2</sup>

### 3. Terminology

3.1 *Definitions*—See definitions of viscosity given in Test Methods D 2171 and D 3205.

<sup>1</sup> This test method is under the jurisdiction of ASTM Committee D-8 on Roofing, Waterproofing, and Bituminous Materials and is the direct responsibility of Subcommittee D08.03 on Surfacing and Bituminous Materials for Membrane Waterproofing and Builtup Roofing.

Current edition approved Nov. 30, 1990. Published January 1991. Originally published as D 4989 – 90. Last previous edition D 4989 – 90.

<sup>2</sup> Annual Book of ASTM Standards, Vol 04.03.

<sup>3</sup> Annual Book of ASTM Standards, Vol 04.04.

### 4. Summary of Test Method

4.1 The sample is molded into a disc of specified dimensions, heated to the selected temperature, placed between the plates of the pre-heated apparatus and pressed under standard conditions for a measured time. The apparent viscosity is calculated from the final diameter of the pressed specimen disc.

### 5. Apparatus

5.1 *Parallel Plate Plastometer*—A modified form of Williams' plastometer as shown in Fig. 1 and Fig. 2. Mass of Platen A is  $5000 \pm 50$  g ( $11.02 \pm 0.11$  lb).

5.2 *Ring Molds*, with an inside diameter of  $25.40 \pm 0.01$  mm ( $1.0000 \pm 0.0025$  in.) and a height of  $12.70 \pm 0.01$  mm ( $0.5000 \pm 0.0025$  in.) cut from copper or brass tubing.

5.3 *Constant Temperature Oven*, capable of maintaining test temperature within  $\pm 0.1^\circ\text{C}$  ( $\pm 0.2^\circ\text{F}$ ).

5.4 *Scale*, linearly graduated in millimetres over at least 150 mm (6 in.) and accurate to  $\pm 0.5$  mm ( $\pm 0.02$  in.).

### 6. Sampling

6.1 Sample the material to be tested in accordance with Practice D 140.

### 7. Test Specimens

7.1 Prepare two molds by coating with a pasty mixture of talc in glycerine as a mold release agent. Coat all surfaces of each mold by brushing or applying the paste with a finger tip. Place the rings on a brass or aluminum plate coated with the release agent.

7.2 Bring the sample to pouring temperature by heating in an oven for not more than 30 min. Heat the sample with care to prevent local overheating, stirring until it has become sufficiently fluid to pour readily. Avoid incorporating air bubbles in the sample. Pour the heated sample into the ring molds until a slight overflow is achieved. Allow to cool at room temperature overnight, and then cut the excess material off cleanly with a slightly heated knife or spatula. Trim the excess material off not more than 1 h before testing.

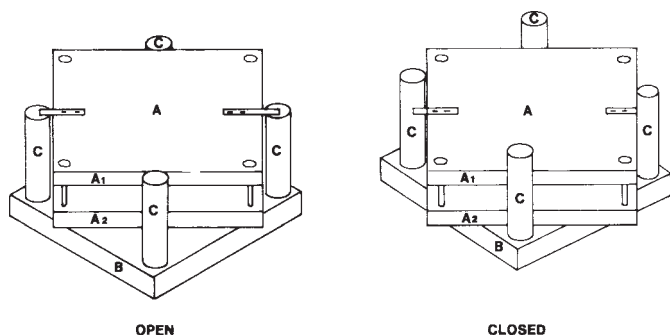

**FIG. 1 Plastometer With Platens in Open and Closed Positions**

7.3 Just prior to testing, carefully remove each specimen from its mold by holding it under a stream of cool tap water and pressing the specimen from the ring with the fingers. Wash the release agent from all surfaces of the specimen in the cool water and gently blot dry with a paper towel.

7.4 Place the dry specimen between two sheets of thin plastic film (see Note 2), approximately 100 by 100 mm (4 by 4 in.).

NOTE 2—Cellophane and polyethylene films, approximately 0.01 mm (2.5 mil) thick, are satisfactory. Do not use TFE-fluorocarbon or nylon, or have any lubricant present, as these will alter the results by allowing the bitumen to slip at the film interface.

## 8. Procedure

8.1 Assemble the apparatus as shown in Fig. 1 and place in an oven at the test temperature overnight prior to the test. Place the prepared test specimen sandwich between the open platens A2 and B as shown in Fig. 3, and allow the entire assembly to stand for 10 min in the oven to bring the specimen to the test temperature.

8.2 After reaching the test temperature, lower the upper platen into contact with the specimen and start timing the test. Leave the load on the specimen for the desired time interval (see Table 1 for suggested intervals), depending on the bitumen type and the test temperature used. The final diameter should be at least 60 mm (2.4 in.).

8.3 At the end of the test period, lift the upper platen immediately and remove the specimen sandwich from the apparatus and the oven. Allow the specimen to cool on a flat surface for at least 30 min.

8.4 Measure the final diameter of the specimen disc at five locations chosen at random and record to the nearest 0.5 mm.

Record the test temperature to the nearest 0.1°C (0.2°F), and the time under load in minutes.

## 9. Calculation

9.1 Calculate the average final diameter of the specimen disc from the five measurements recorded.

9.2 Calculate the average apparent viscosity as follows:

$$Pa \cdot s = \frac{3.60 \times 10^{18} t}{(d)^8}; \left( \text{viscosity, cps} = \frac{2.08 \times 10^{10} t}{d^8} \right) \quad (1)$$

where:

$t$  = time interval of the test in minutes, and

$d$  = final average diameter of the specimen in inches (millimetres) (see Note 3).

NOTE 3—National Institute of Standards and Technology, NBS Report 10950, Appendix B,<sup>4</sup> and Dienes and Klemm, Journal of Applied Physics.<sup>5</sup>

## 10. Report

10.1 The report shall include the following:

10.1.1 Complete sample identification,

10.1.2 Test temperature,

10.1.3 Conditioning time, and

10.1.4 Parallel-plate viscosity, in centipoises (Pascal-seconds).

## 11. Precision and Bias

11.1 Preliminary data show the following criteria shall be used for judging the acceptability of results (95 % probability). Additional round robin data may alter these values. The precision for Type III bitumens has not been established.

11.1.1 *Repeatability*— Duplicate results by the same operator using the same apparatus shall not be considered suspect unless they differ by more than 5 % of their mean.

11.1.2 *Reproducibility*— The results submitted by each of two laboratories shall not be considered suspect unless the two results differ by more than 20 % of their mean.

## 12. Keywords

12.1 apparent viscosity; bitumen; flow; parallel plate; plastometer; viscosity

<sup>4</sup> Available from National Institute of Standards and Technology (NIST), Gaithersburg, MD 20899.

<sup>5</sup> Journal of Applied Physics, Vol 17, p. 458, 1946.



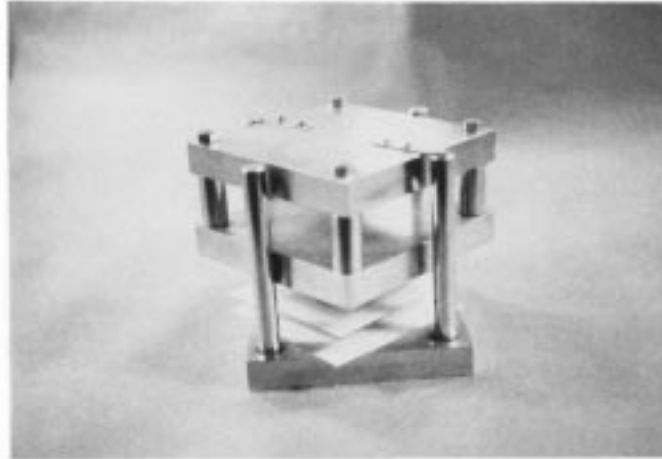

**FIG. 3 Specimen Between Sheets of Cellophane, Placed in Plastometer Before Lowering Weight for Start of Test**

**TABLE 1 Approximate Test Time Intervals for Various Bitumen Types**

Bitumen Type	Softening Point°C (° F)	Viscosity Range, Pascals, and Approximate Length of Test at Temperature Indicated		
		25°C (77°F)	40°C (104°F)	60°C (140°F)
1 <sup>A</sup>	57 to 66 (135 to 150 )	(1 to 5) × 10 <sup>7</sup> (20 h)	(1 to 5) × 10 <sup>5</sup> (10 min)	(1 to 5) × 10 <sup>3</sup> (10 s)
2 <sup>A</sup>	71 to 79 (160 to 175 )	(1 to 5) × 10 <sup>8</sup> (3 days)	(1 to 5) × 10 <sup>6</sup> (1 h)	(1 to 5) × 10 <sup>4</sup> (1 min)
3 <sup>A</sup>	82 to 93 (180 to 200)	(1 to 5) × 10 <sup>9</sup> (1 week)	(5 to 10) × 10 <sup>7</sup> (20 h)	(5 to 10) × 10 <sup>5</sup> (15 min)
4 <sup>A</sup>	96 to 107 (205 to 225)	(1 to 5) × 10 <sup>10</sup> (2 months)	(1 to 5) × 10 <sup>9</sup> (1 week)	(1 to 5) × 10 <sup>7</sup> (20 h)
Pitch <sup>B</sup>	54 to 62 (129 to 144)	(1 to 5) × 10 <sup>9</sup> (1 week)	(1 to 5) × 10 <sup>6</sup> (1 h)	(1 to 5) × 10 <sup>4</sup> (1 min)

<sup>A</sup>Asphalt type as described in Specification D 312.

<sup>B</sup>Coal-tar pitch as described in Specification D 450.

*The American Society for Testing and Materials takes no position respecting the validity of any patent rights asserted in connection with any item mentioned in this standard. Users of this standard are expressly advised that determination of the validity of any such patent rights, and the risk of infringement of such rights, are entirely their own responsibility.*

*This standard is subject to revision at any time by the responsible technical committee and must be reviewed every five years and if not revised, either reapproved or withdrawn. Your comments are invited either for revision of this standard or for additional standards and should be addressed to ASTM Headquarters. Your comments will receive careful consideration at a meeting of the responsible technical committee, which you may attend. If you feel that your comments have not received a fair hearing you should make your views known to the ASTM Committee on Standards, at the address shown below.*

*This standard is copyrighted by ASTM, 100 Barr Harbor Drive, PO Box C700, West Conshohocken, PA 19428-2959, United States. Individual reprints (single or multiple copies) of this standard may be obtained by contacting ASTM at the above address or at 610-832-9585 (phone), 610-832-9555 (fax), or service@astm.org (e-mail); or through the ASTM website (www.astm.org).*