



Standard Test Method for Determining the In Situ Modulus of Deformation of Rock Mass Using the Rigid Plate Loading Method¹

This standard is issued under the fixed designation D 4394; the number immediately following the designation indicates the year of original adoption or, in the case of revision, the year of last revision. A number in parentheses indicates the year of last reapproval. A superscript epsilon (ϵ) indicates an editorial change since the last revision or reapproval.

1. Scope

1.1 This test method covers the preparation, equipment, test procedure, and data reduction for determining in situ modulus of deformation of a rock mass using the rigid plate loading method.

1.2 This test method is designed to be conducted in an adit or small underground chamber; however, with suitable modifications it could be conducted at the surface.

1.3 This test method is usually conducted parallel or perpendicular to the anticipated axis of thrust, as dictated by the design load.

1.4 Time dependent tests can be performed but are to be reported in another standard.

1.5 The values stated in inch-pound units are to be regarded as the standard.

1.6 The references appended to this standard contain further information on this test method.

1.7 *This standard does not purport to address all of the safety concerns, if any, associated with its use. It is the responsibility of the user of this standard to establish appropriate safety and health practices and determine the applicability of regulatory limitations prior to use.* For specific precaution statements, see Section 8.

2. Referenced Documents

2.1 ASTM Standards:

D 4395 Test Method for Determining the In Situ Modulus of Deformation of Rock Mass Using the Flexible Plate Loading Method²

D 4403 Practice for Extensometers Used in Rock²

3. Terminology

3.1 Definitions of Terms Specific to This Standard:

3.1.1 *deflection*—movement of the rigid plate, mortar pad, or rock in response to and in the same direction as the applied load.

3.1.2 *load*—total force acting on the rock face.

3.1.3 *peak-to-peak modulus of deformation*—the slope of the stress - strain curve line connecting the peaks of the curves

obtained from successive pressure cycles (see Fig. 1).

3.1.4 *recovery modulus of deformation*—the tangent modulus of the unloading stress - strain curve. This modulus is usually higher than the other moduli and is used in calculations where unloading conditions exist. The difference between the tangent and recovery moduli indicates that material's capacity of hysteresis or energy dissipation capabilities (see Fig. 2).

3.1.5 *rigid plate*—plate with deflection of less than 0.0001 in. (0.0025 mm) from center to edge of plate, when maximum load is applied.

3.1.6 *secant modulus of deformation*—the slope of the stress-strain curve between zero stress and any specified stress. This modulus should be used for complete load steps from zero to the desired load (see Fig. 2).

3.1.7 *tangent modulus of deformation*—the slope of the stress - strain curve obtained over the segment of the loading curve judged by the investigator as the most representative of elastic response. It neglects the end effects of the curve and is better suited to small stress changes. The ratio between the secant modulus and the tangent modulus can be used as a means of measuring the stress damage of the material (see Fig. 2).

4. Summary of Test Method

4.1 Areas on two opposing parallel faces of a test adit are flattened and smoothed.

4.2 A mortar pad and rigid metal plate are installed against each face and a hydraulic loading system is placed between the rigid plates.

4.3 If deflection is to be measured within the rock mass, extensometer instruments should be installed in the rock in accordance with Practice D 4403.

4.4 The two faces are loaded and unloaded incrementally and the deformations of the rock mass at the surfaces and, if desired, within the rock, are measured after each increment. The modulus of deformation is then calculated.

5. Significance and Use

5.1 Results of this type of test method are used to predict displacements in rock mass caused by loads from a structure or from underground construction. It is one of several tests that should be performed. The resulting in situ modulus is commonly less than the elastic modulus determined in the laboratory.

¹ This test method is under the jurisdiction of ASTM Committee D-18 on Soil and Rock and is the direct responsibility of Subcommittee D18.12 on Rock Mechanics.

Current edition approved Nov. 12, 1984. Published January 1985.

² *Annual Book of ASTM Standards*, Vol 04.08.

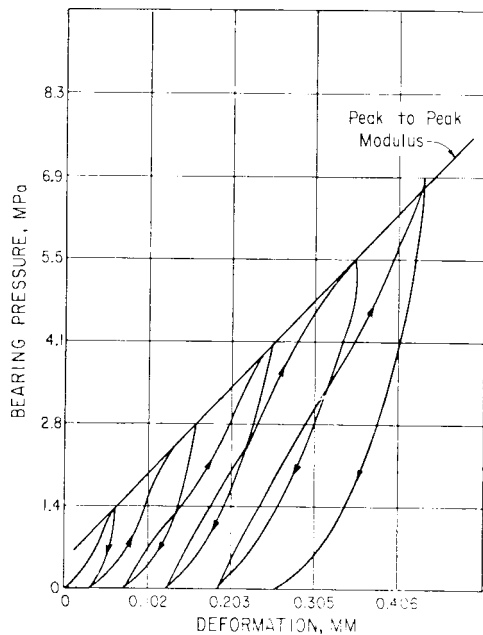

FIG. 1 Rock Surface Deformation as a Function of Bearing Pressure

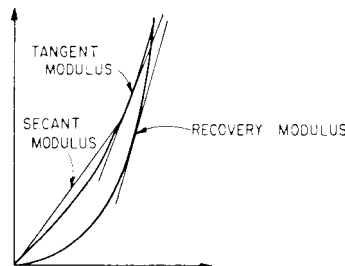

FIG. 2 Relationship Between Tangent, Secant and Recovery Moduli

5.2 The modulus is determined using an elastic solution for a uniformly distributed load (uniform stress) over a circular area acting on a semi-infinite elastic medium.

5.3 This test method is normally performed at ambient temperature, but equipment can be modified or substituted for operations at other temperatures.

6. Interferences

6.1 A completely inflexible plate used to load the rock face is difficult to construct. However, if the plate is constructed as rigid as possible, the rock face is smoothed, and a thin, high-modulus material is used for the pad, the error is minimal.

6.2 The rock under the loaded area is generally not homogeneous, as assumed in theory. Rock will respond to the load according to its local deformational characteristics. Therefore, deflection measurements at discrete points on the rock surface tend to be heavily influenced by the deformational characteristics of the rock mass at that location and may give results that are unrepresentative of the rock mass. The use of the average plate deflection will mitigate this problem.

6.3 Measurement of the deflection within the rock mass can utilize a finite gage length to reflect the average rock mass deformation properties between the measuring points. This

approach entails three drawbacks, however. First, the rock mass is tested at very low stress levels unless the measurement points are very close to the rock surface, and because of this, the same problems as with surface measurements occur. Tests at low stress levels may give unrealistically low modulus values because microfractures, joints, and other discontinuities in the rock are open. Secondly, the disturbance caused by implanting the deflection transducer in the rock mass is difficult to evaluate. The techniques in this test method are designed to produce minimal disturbance. Thirdly, in rocks with very high modulus, the accuracy of the instruments may be insufficient to provide reliable results.

6.4 Time-rate of loading has negligible influence on the modulus.

6.5 Calculations neglect the stress history of the rock.

6.6 This test method is insensitive to Poisson's ratio, which must be assumed or obtained from laboratory testing.

7. Apparatus

7.1 Equipment necessary for accomplishing this test method includes items for: preparing the test site, drilling and logging the instrumentation holes, measuring the rock deformation, applying and restraining test loads, recording test data, and transporting various components to the test site.

7.2 *Test Site Preparation Equipment*— This should include an assortment of excavation tools, such as drills and chipping hammers. Blasting shall not be allowed during final preparation of the test site. The drill for the instrumentation holes should, if possible, have the capability of retrieving cores from depths of at least 30 ft (10 m).

7.3 *Borehole Viewing Device*—Some type of device is desirable for examination of the instrumentation holes to compare and verify geologic features observed in the core if core recovery is poor or if it is not feasible to retrieve oriented cores.

7.4 *Deformation Measuring Instruments*— Instruments for measuring deformations should include a reliable multiple-position borehole extensometer (MPBX) for each instrumentation hole and a tunnel diameter gage. For surface measurements, dial gages or linear variable differential transformers (LVDTs) are generally used. An accuracy of at least ± 0.0001 in. (0.0025 mm), including the error of the readout equipment, and a sensitivity of at least 0.00005 in. (0.0013 mm) is recommended. Errors in excess of 0.0004 in. (0.01 mm) can invalidate test results when the modulus of rock mass exceeds 5×10^6 psi (3.5×10^4 MPa).

7.5 *Loading Equipment*—The loading equipment includes the device for applying the load and the reaction members (usually thick-walled aluminum or steel pipes) which transmit the load. Hydraulic rams or flatjacks are usually used to apply the load hydraulically with sufficient capability and volume to apply and maintain desired pressures to within 3%. If flatjacks are used they should have sufficient range to allow for deflection of the rock and should be constructed so that the two main plates move apart in a parallel manner over the usable portion of the loading range. A spherical bearing of suitable capacity should be coupled to one of the bearing plates.

7.6 *Load Cells and Transducers*—A load cell is recommended to measure the load on the bearing plate. An accuracy

of at least ± 1000 lbf (± 4.4 kN), including errors introduced by the readout system, and a sensitivity of at least 500 lbf (2.2 kN) are recommended. Alternatively, a pressure gage or transducer may be used to monitor hydraulic pressure for calculation of load, provided the device can measure the load to the same specifications as the load cell. An accuracy should be at least ± 20 psi (± 0.14 MPa), including error introduced by readout equipment, and a sensitivity of at least 10 psi (0.069 MPa). If a hydraulic ram is used, the effects of ram friction shall be determined. If flatjacks are used, care shall be taken that the jacks do not operate at the upper end of their range.

7.7 *Bearing Pads*—The bearing pads should have a modulus of elasticity of at least 4×10^6 psi (3×10^4 MPa) and should be capable of conforming to the rock surface and bearing plate. High-early strength grout or molten sulfur bearing pads are recommended.

7.8 *Bearing Plates*—The bearing plates should approximate a rigid die as closely as practical. A bearing plate that has been found satisfactory is shown on Fig. 3. Although the exact design and materials may differ, the stiffness of the bearing plate should at least be the minimum stiffness necessary to produce no measurable deflection of the plate under maximum load.

8. Safety Hazards

8.1 All personnel involved in performing the test should be formally prequalified under the quality assurance procedures listed in Annex A1.

8.2 Verify the compliance of all equipment and apparatus with the performance specifications in Section 7. If no requirements are stated, the manufacturer’s specifications for the equipment may be appropriate as a guide, however, care must be taken for sufficient performance. Performance verification is generally done by calibrating the equipment and measurement system. Accomplish calibration and documentation in accordance with the quality assurance procedures.

8.3 Enforce safety by applicable safety standards. Pressure lines must be bled of air to preclude violent failure of the pressure system. Total deformation should not exceed the expansion capabilities of the flatjacks; normally this is approximately 3 % of the diameter of a metal jack.

9. In-Situ Conditions

NOTE 1—The guidelines presented in this section are the domain of the agency or organization requesting the testing and are intended to facilitate definition of the scope and development of site-specific requirements for the testing program as a whole.

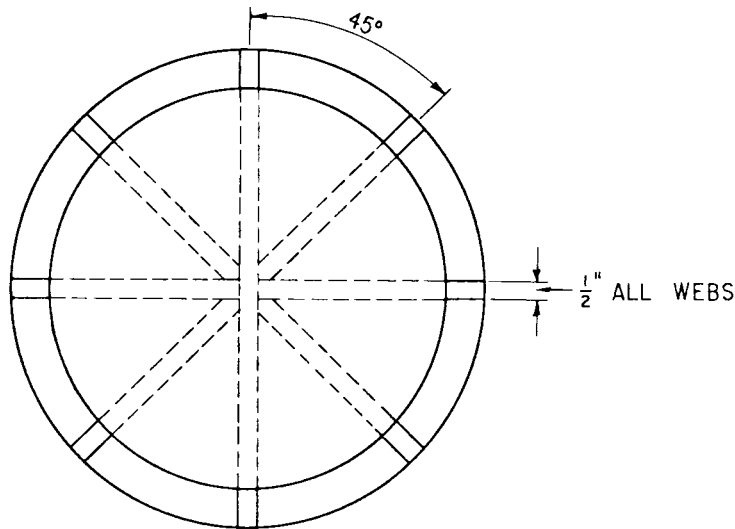

NOTE: ALL JOINTS FULLY WELDED

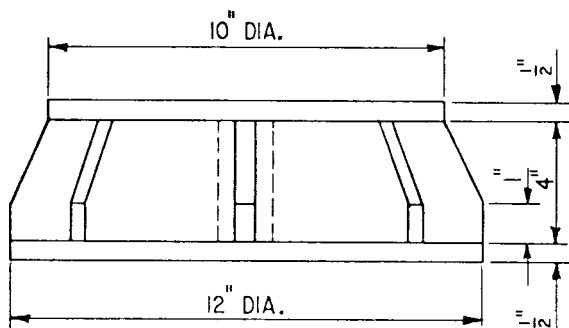

FIG. 3 Rigid Bearing Plate for 12 in. Diameter Test

9.1 Test each structurally distinctive zone of rock mass selecting areas that are geologically representative of the mass. Test those portions of the rock mass with features such as faults, fracture zones, cavities, inclusions, and the like to evaluate their effects. Design the testing program so that effects of local geology can be clearly distinguished.

9.2 The size of the plate will be determined by local geology, pressures to be applied, and the size of the adit to be tested. These parameters should be considered prior to excavation of the adit. Optimum adit dimensions are approximately six times the plate diameter; recommended plate diameter is commonly 1½ to 3¼ ft (0.5 to 1 m). Other sizes are used depending upon site specifics.

9.3 The affects of anisotropy should be investigated by appropriately oriented tests: for example, parallel and perpendicular to the bedding of a sedimentary sequence, or parallel and perpendicular to the long axes of columns in a basalt flow.

9.4 Tests shall be performed at a site not affected by structural changes resulting from excavations of the adit. The zone of rock that contributes to the measured deflection during the plate loading test depends on the diameter of the plate and the applied load. Larger plates and higher loads measure the response of rock further away from the test adit. Thus, if the rock around the adit is damaged by the excavation process, and the deformational properties of the damaged zone are the primary objective of the test program, small-diameter plate tests on typically excavated surfaces are adequate. If the undisturbed in-situ modulus is desired, larger diameter plates and higher loads may be used, although practical considerations often limit the size of the equipment. Alternatively, careful excavation procedures, such as presplitting or other types of smooth-wall blasting, may be employed in the test area to limit damage to the rock and the resulting need for large plates and loads.

9.5 Cores, if any, should be logged and tested for rock quality designation (RQD), fracture spacing and orientation, condition of joint surfaces, strength, and deformation.

9.6 Site conditions may dictate that site preparation and pad construction be performed immediately after excavation.

10. Procedure

10.1 A schematic of an optimum test setup is shown in Fig. 4. A properly located wooden platform (not shown) allows for alignment of all test components.

10.2 Conduct the test across a “diameter” or chord of the adit with the two test surfaces nearly parallel and in planes oriented perpendicular to the thrust of the loading assembly.

10.3 Surface Preparation:

10.3.1 *Method*—Prepare the surface by a method that will cause minimal damage to the finished rock surface. Drilling may be required to reach uniform depth. Residual rock between the drill holes may be removed by burnishing or moving the bit back and forth until a smooth face is achieved. Alternatively, in hard, competent rock, controlled blasting with very small charges may be required to remove the residual materials. In weaker materials, coarse grinding or cutting devices may be used.

10.3.2 *Size*—The prepared rock surface should extend at least one-half the diameter of the bearing plate beyond the edge of the plate.

10.3.3 *Rock Quality*—To the extent possible, prepare the bearing surface in sound rock. Remove loose and broken rock from the excavation. Deeper breaks may be detected by a dull hollow sound when the rock surface is struck with a hammer; remove such material.

10.3.4 *Smoothness*—The prepared rock face should be as smooth as practicable. In no case should the deviation from a

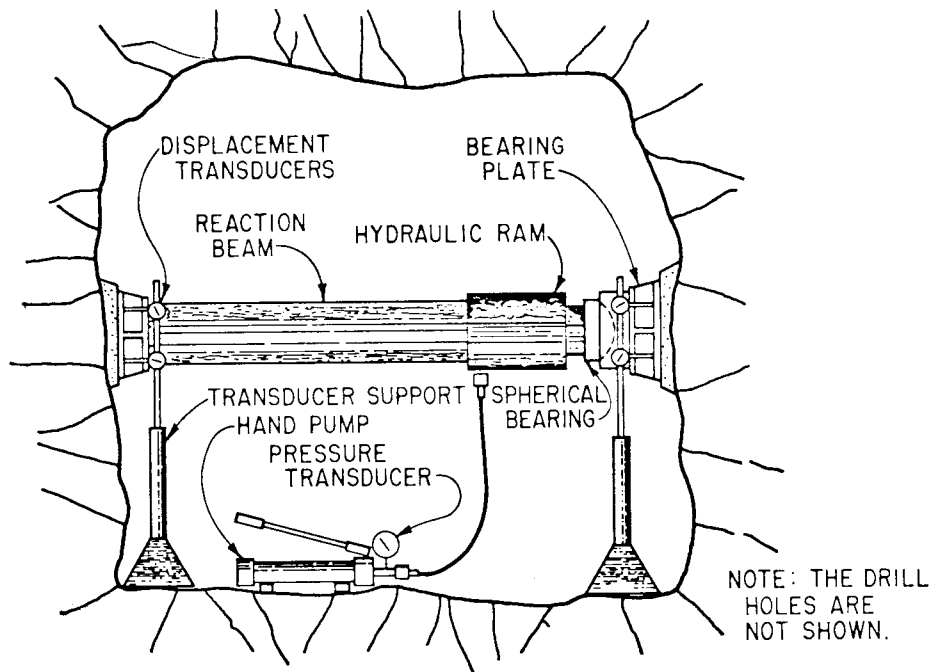

FIG. 4 Typical Rigid Plate Bearing Test Setup Schematic

plane between the highest and lowest points exceed 1 in. (25 mm).

10.3.5 *Cleaning*—After the surface has been prepared, scrub and rinse it with clean water to remove any loose particles or dirt caused by the smooth operation.

10.4 *Bearing Pad Construction*—Construct the bearing pad, with the bearing plate in position, by pouring the pad material between the rock surface and the plate. Contain the pad material by suitable form work around the edges of the plate. The only exception to this method is for near vertical tests where cement pads are used. In this case, the lower bearing plate may be placed directly upon the pad prior to curing. In all cases, exercise care to avoid air pockets or other cavities within the pad. The thickness of the pad should be no more than 1.5 in./ft (38 mm/0.305 m) of flatjack diameter at any point. The dimensional requirements are shown in Fig. 5.

10.5 *Measuring Points:*

10.5.1 *Surface Measurements*—Take deformation measurements on the rock surface at the edge of the bearing pad at a minimum of six equally spaced intervals around the edge of each pad. Secure reference pads to the rock surface at surface measurement points. Measure the deflection of the bearing plate in at least three equally spaced locations around the plate. The displacement transducers should be supported so that only the deflection of the rock itself is measured. Generally, this means mounting the transducers from supports located outside the zone of influence of the test. In no case should the transducers be mounted on the loading apparatus. Install cross tunnel measurement points and equipment such as described in Practice D 4403.

10.5.2 *Measurements Within the Rock Mass:*

10.5.2.1 If deformation measurements in the rock mass are required they should be taken along a line within 5° of the direction of loading and located no farther from center line than 10 % of the width of the bearing pad.

10.5.2.2 The holes for instruments should be as small as feasible. Holes should be diamond-rotary drilled on opposing surfaces and continuously cored and logged.

10.5.2.3 Select the location of each measurement point by examining the rock core and inspecting the borehole with a borescope or other suitable device. In general, place measuring points on either side of joints, thin beds, seams, and the like.

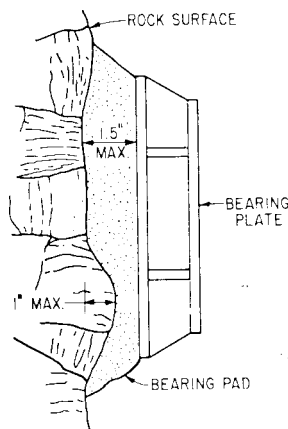

FIG. 5 Allowable Dimensions for Rock Surface and Bearing Pad

Place at least two measuring points within one plate diameter of the rock surface. Locate the deepest two measuring points at least six plate diameters from the bearing surface outside the calculated zone of measured influence. Other instrument arrangements may be appropriate for specific geologic conditions.

10.5.2.4 The installation and recording procedures for the measuring instruments or extensometers are presented in Practice D 4403. The extensometer leads extend out from the hole and exit out the side of the bearing pad. Prior to casting the pads, shield the leads with polyvinyl chloride or rubber tubing.

10.5.2.5 The accuracy and sensitivity of the instruments chosen should be compatible with the anticipated modulus values. The error associated with a single test shall be evaluated. This includes the combined effects of all transducers, power supplies, readout devices, and the like.

10.6 *Pretest Check*—Electronically or mechanically check all components of the instrumentation after they are installed in the drill holes. After the loading and restraining components are installed, make another check of the instrumentation. Make final checks of all mechanical, hydraulic, and electronic components after the concrete pads are placed and again before the first load increment is applied.

10.7 *Pressurization Cycles:*

10.7.1 Observations during the first pressure cycle can be used to modify time rate requirements for successive cycles.

10.7.2 In general, five pressure cycles to peak pressure, each in ten increments at 1 min per increment, are adequate. The middle cycle should be approximately at design load with the upper cycle approximately two times the design load, if possible. The cycles need not be uniformly spaced. The unloading phase of each cycle should be at the same rate as the loading rate, holding at zero load until creep has stabilized. Take deflection readings after each load increment and decrement. Maintain the peak and zero pressures for each cycle for at least 10 min, with deflection readings taken at 5-min intervals. A typical five-cycle loading sequence is shown in Fig. 2.

10.7.3 Regardless of any modifications of the foregoing procedures, peak pressures must be held for at least 10 min.

10.7.4 If required, both instantaneous deformation and primary creep can be obtained from this test method. Fig. 6 shows a time deformation relationship with incremental loading.

10.7.5 *Data*—Record the data shown on the example form in Fig. 7 as a minimum for each test.

11. Calculation

11.1 The equation for the modulus of deformation is based on the elastic solution for a rigid die (constant deflection) pressed into the surface of a semi-infinite isotropic elastic medium.

11.2 The modulus, E , is calculated as follows:

$$E = \frac{(1 - \gamma^2)P}{2W_c R} \quad (1)$$

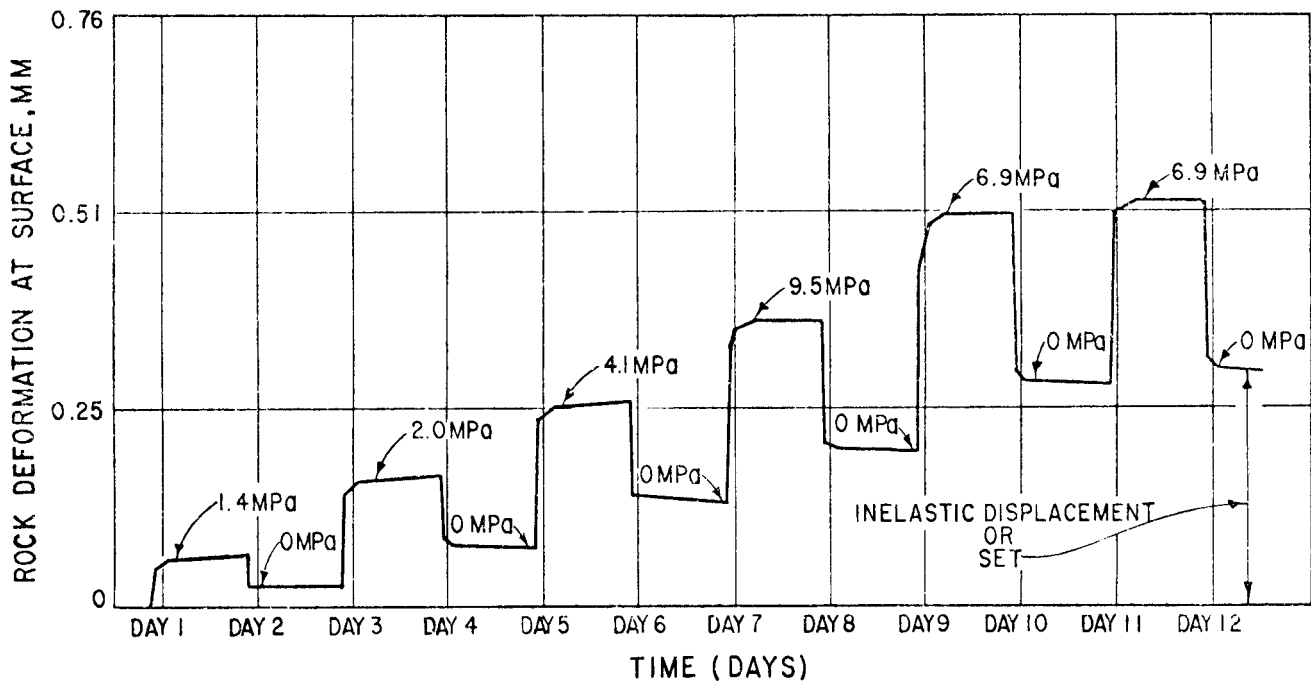

FIG. 6 Rock Deformation at Surface Versus Time

where:

- γ = Poisson's ratio of the rock,
- P = total load on the rigid plate, lbf (kN),
- W_a = average deflection of the rigid plate, in. (mm), and
- R = radius of the rigid plate, in. (mm).

11.3 For each rock material or structure, calculate the mean modulus value, range, standard deviation, and 95 % confidence limits for the mean, as a minimum.

12. Report

12.1 The purpose of this section is to establish the minimum requirements for a complete and usable report. Further details may be added as appropriate, and the order of items may be changed as necessary. Applications of the test results are beyond the scope of this test method, but may be an integral part of some testing programs. In such a case, an applications section compatible with the format described below should be included.

12.2 Introductory Section of the Report:

12.2.1 The introductory section is intended to present the scope and purpose of the testing program and the characteristics of the material tested. The introductory section includes:

12.2.1.1 Scope of Testing Program.

12.2.1.2 *Test Locations*—Including the location and orientation of the plate loading test; a graphic presentation is recommended.

12.2.1.3 *Test Rationale*—A discussion of the reasons for selecting the test locations.

12.2.1.4 *Limitations of the Testing Program*— Discuss the areas of interest which are not covered by the testing program and the limitations of the data within the areas of application, in general terms.

12.2.1.5 *Description of the Test Site Geology*—A complete geologic description of the test site including core logs, photos

of core, photos of prepared test areas, and a description of local blast damage; macroscopic description of the rock types; description of structural features affecting the test; and diagrams of the geology of the test area, both before and after testing, are recommended.

12.3 Test Method Section:

12.3.1 *Equipment and Apparatus*—A detailed listing of the equipment actually used for the test and the name, model number, and basic specifications of each major piece.

12.3.2 *Procedure*—Detailed steps of the procedure actually used for the test.

12.3.3 *Variations*—If the actual equipment or procedure varies from the requirements contained in this test method, note each variation and the reasons for it; also discuss the affect of the variation upon the test results.

12.4 Theoretical Background Section:

12.4.1 *Data Reduction Equations*—All equations used to reduce the data should be clearly presented and fully defined; note any assumptions inherent in the equations or limitations in their applications; and discuss the affect on the results.

12.4.2 Site-Specific Influences:

12.4.2.1 *Assumptions*—Discuss in detail the differences between actual test site conditions and conditions assumed in the data reduction equations. Estimate the affects of such differences on numerical results, as much as feasible.

12.4.2.2 *Correction Factors*—Fully explain any factors or methods applied to the data to correct for a nonideal situation.

12.5 Results Section:

12.5.1 *Summary Table*—Present a summary table including the characteristics of the rock materials, the pressure range over which the modulus values were calculated, the average modulus values, ranges, and uncertainties.

12.5.2 *Table of Individual Results*—Present a table listing test number, rock material/structure, and average modulus

 **D 4394**

Project _____ Test No. _____
 Feature _____ Rock Type _____
 Test Location _____ Plate Diameter _____
 Orientation _____ Tested By _____

Measurement Depths No. 1 _____ No. 4 _____
 No. 2 _____ No. 5 _____
 No. 3 _____ No. 6 _____

Equipment Description	Serial No.	Date of Next Calibration

Time	Load Reading	Deflection Readings					
		No. 1	No. 2	No. 3	No. 4	No. 5	No. 6

Time	Load Reading	Displacement Reading		
		No. 1	No. 2	No. 3

Remarks:

Test Supervisor _____ Date _____
 Quality Assurance _____ Date _____
 Project Engineer _____ Date _____

FIG. 7 In-Situ Modulus of Deformation Test Data Sheet

values for each test location. Take care to identify the depth interval in the rock mass and stress range for each modulus.

12.5.3 *Graphic Presentations*—Present a typical average deflection curve for each rock material.

12.5.4 *Other*—The following other types of analyses and presentations may be included as appropriate:

- 12.5.4.1 Relationship between modulus and applied stress.
- 12.5.4.2 Discussion of modulus dependence on geology.

12.5.4.3 Histograms of results.

12.5.4.4 Comparison with laboratory modulus values or the results of other in situ modulus tests.

12.5.4.5 Comparison of results to other rock types or previous studies.

12.6 Appended Data—An appendix is recommended and should include:

12.6.1 A completed test data form (Fig. 7) for each test.

12.6.2 Plots of deformation versus pressure, such as Fig. 2. Information from this plot can be used to determine the shape of the stress - strain curve, to obtain values for calculation of various moduli, and to determine rebound and elasticity characteristics.

12.6.3 Plots of deformation versus time, as in Fig. 6. This plot is useful for studying the creep characteristics of the rock. It should be kept during testing to establish time requirements for each load increment.

12.6.4 Plots of deformation versus depth referenced to the deepest anchor, as in Fig. 8. This deformation profile is used to identify anomalous areas with lower or higher moduli than the average. Once such zones are identified, they can be correlated with core from the instrument holes. If MPBX anchors are located properly, the moduli of these zones can be calculated using the equations in Section 11. Also see the calculations of Test Method D 4395.

13. Precision and Bias

13.1 Precision—Due to the nature of rock materials tested by this test method, it is, at this time, either not feasible or too costly to produce multiple specimens which have uniform physical properties. Therefore, since specimens which would yield the same test results cannot be tested, Subcommittee D18.12 cannot determine the variation between tests since any variation observed is just likely to be due to specimen variation as to operator or laboratory testing variation. Subcommittee D18.12 welcomes proposals to resolve this problem that would allow for development of a valid precision statement.

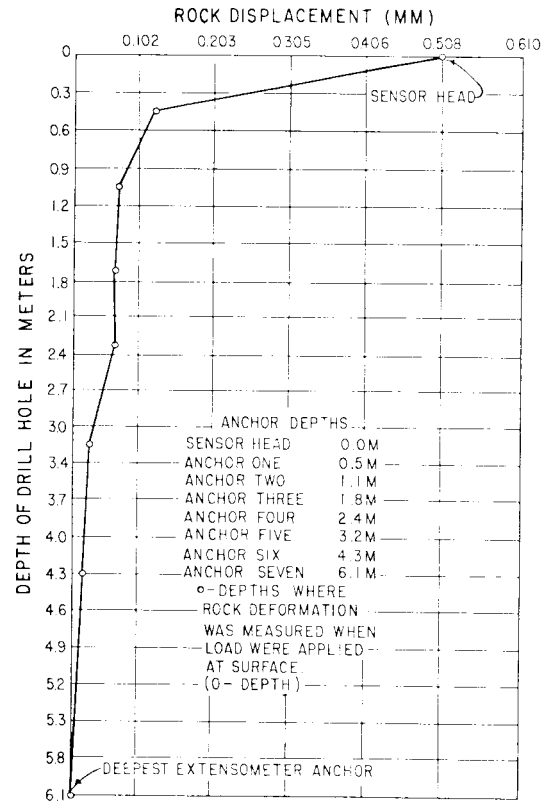

FIG. 8 Uniaxial Displacement Versus Depth, Referenced to Deepest Anchor

13.2 Bias—There is no accepted reference value for this test method; therefore, bias cannot be determined.

14. Keywords

14.1 adit; deformation; displacement; field testing; fracture testing; loading tests; modulus of deformation; pressure testing; rigid plate loading method; rock; stress; underground environments

Project (Date)	Type of Rock	No. of Tests	E_F (GPa) ^A	E_L (FPa) ^A	E_F/E_L
Oroville Dam (1961)	Amphibolite (massive)	5	10.4	89.0	0.11
Tumut 2 (1962)	Gneiss/granite	6	6.9	59.1	0.12
Dworshak Dam (1966)	Granite/gneiss (Massive)	24	23.5	51.7	0.45
Tehachapi Tunnel (1967)	Diorite gneiss (fracture)	4	4.8	77.9	0.06
Crestmore Mine (1966 to 1974)	Marble (blocky)	2	15.0	47.5	0.31
Gordon Scheme	Quartzite	8	19.0	67.0	0.28
Churchill Falls (1971)	Gneiss	10	41.5	55.0	0.75
Waldeck II (1973)	Greywacke	Not known	5.0	20.0	0.25
Mica Project (1974)	Quartzite gneiss	12	27.6	27.0	1.04
LG-2 Project (1976)	Granite (massive)	Not known	50.0	80.0	0.62
Elandsberg (1977)	Greywacke	33	39.6	73.4	0.54

^ANote— E_F , field modulus; E_L , laboratory modulus at 50 % strength.

FIG. 9 Field and Laboratory Moduli by Plate Bearing Test at Major Projects

ANNEX

(Mandatory Information)

A1. QUALITY ASSURANCE

A1.1 The following items are the minimum requirements to ensure that the test results are defensible and traceable. It is not the intent of this annex to establish quality assurance procedures, but to identify those points during the test at which quality assurance action is recommended.

A1.1.1 Personnel Prequalification

Prior to testing, all personnel should be prequalified.

A1.1.2 *Test Inspection*— Quality assurance personnel should review the test setup, procedure, and equipment performance verification. After testing, the completed form (Fig. 7) should be reviewed and signed off only if correct.

A1.1.3 Required Documentation:

A1.1.3.1 *Equipment Performance Verification*—Quality assurance should maintain complete calibration records and certificates.

A1.1.3.2 *Equipment Serial Numbers*—Quality assurance should verify that serial numbers of all equipment used in the test are recorded on the form (Fig. 7).

A1.1.3.3 *Test Signoffs*— Quality assurance should maintain signed-off copies of the form (Fig. 7).

REFERENCES

- (1) International Society for Rock Mechanics, Commission on Standardization of Laboratory and Field Tests, "Suggested Methods for Determination In Situ Deformability of Rock," *International J. Rock Mechanics Min. Sci. and Geomechanics Abstract*, Vol 16, No. 2, 1979, pp. 143–148.
- (2) Shuri, F. S., Feves, M. L., Peterson, G. L., Foster, K. M., and Kienle, C. F., Jr., *Field and In Situ Rock Mechanics Testing Manual*, ONWI-310, Foundation Sciences, Portland, OR, 1981, pp. D.2-1–2-10 and 2 data sheets.
- (3) *Symposium on Testing Techniques for Rock Mechanics*, ASTM STP 402, ASTM.
- (4) *Symposium on Determination of the In Situ Modulus of Deformation of Rock*, ASTM STP 477, ASTM.

The American Society for Testing and Materials takes no position respecting the validity of any patent rights asserted in connection with any item mentioned in this standard. Users of this standard are expressly advised that determination of the validity of any such patent rights, and the risk of infringement of such rights, are entirely their own responsibility.

This standard is subject to revision at any time by the responsible technical committee and must be reviewed every five years and if not revised, either reapproved or withdrawn. Your comments are invited either for revision of this standard or for additional standards and should be addressed to ASTM Headquarters. Your comments will receive careful consideration at a meeting of the responsible technical committee, which you may attend. If you feel that your comments have not received a fair hearing you should make your views known to the ASTM Committee on Standards, at the address shown below.

This standard is copyrighted by ASTM, 100 Barr Harbor Drive, PO Box C700, West Conshohocken, PA 19428-2959, United States. Individual reprints (single or multiple copies) of this standard may be obtained by contacting ASTM at the above address or at 610-832-9585 (phone), 610-832-9555 (fax), or service@astm.org (e-mail); or through the ASTM website (www.astm.org).