



Standard Test Methods for X-Ray Radiography of Soil Samples¹

This standard is issued under the fixed designation D 4452; the number immediately following the designation indicates the year of original adoption or, in the case of revision, the year of last revision. A number in parentheses indicates the year of last reapproval. A superscript epsilon (ϵ) indicates an editorial change since the last revision or reapproval.

^{€1} NOTE—Editorial changes were made in August 2002.

1. Scope *

1.1 These test methods cover the determination of the quality of soil samples by X-ray radiography.

1.2 These test methods enable the user to determine the effects of sampling and natural variations within samples as identified by the extent of the relative penetration of X rays through soil samples.

1.3 These test methods can only be used to their fullest extent after considerable experience is obtained through many detailed comparisons between the X-ray film and the sample X-rayed.

1.4 The values stated in inch-pound units are to be regarded as the standard.

1.5 *This standard does not purport to address all of the safety concerns, if any, associated with its use. It is the responsibility of the user of this standard to establish appropriate safety and health practices and determine the applicability of regulatory limitations prior to use.* For specific precaution statements, see Section 6.

2. Referenced Documents

2.1 ASTM Standards:

D 653 Terminology Relating to Soil, Rock, and Contained Fluids²

D 3740 Practice for Minimum Requirements for Agencies Engaged in the Testing and/or Inspection of Soil and Rock as Used in Engineering Design and Construction²

E 7 Terminology Relating to Metallography³

3. Terminology

3.1 Definitions:

3.1.1 For definitions of terms relating to soil samples, refer to Terminology D 653.

3.1.2 For definitions of terms relating to X rays, refer to Definitions E 7.

4. Significance and Use

4.1 Many geotechnical tests require the utilization of undisturbed, representative samples of soil deposits. The quality of these samples depends on many factors. Many of the samples obtained by undisturbed sampling methods have inherent anomalies. Sampling procedures cause disturbances of varying types and intensities. These anomalies and disturbances, however, are not always readily detectable by visual inspection of the undisturbed samples before or after testing. Often test results would be enhanced if the presence and the extent of these anomalies and disturbances are known before testing or before destruction of the sample by testing. Such determinations assist the user in detecting flaws in sampling methods, the presence of natural or induced shear planes, the presence of natural intrusions, such as gravels or shells at critical regions in the samples, the presence of sand and silt seams, and the intensity of some of the unavoidable disturbances caused by sampling.

4.2 X-ray radiography provides the user with a picture of the internal massive structure of the soil sample, regardless of whether the soil is X-rayed within or without the sampling tube. X-ray radiography assists the user in identifying the following:

4.2.1 Appropriateness of sampling methods used,

4.2.2 Effects of sampling in terms of the disturbances caused by the turning of the edges of various thin layers in varved soils, large disturbances caused in soft soils, shear planes induced by sampling, or extrusion, or both, effects of overdriving of samplers, the presence of cuttings in sampling tubes, or the effects of using bent, corroded, or nonstandard tubes for sampling,

4.2.3 Naturally occurring fissures, shear planes, and the like,

4.2.4 The presence of intrusions within the sample, such as calcarious nodules, gravel, or shells, and

4.2.5 Sand and silt seams, organic matter, large voids, and channels developed by natural or artificial leaching of soils components.

NOTE 1—The quality of the results produced by this standard is dependent on the competence of the personnel performing it, and the suitability of the equipment and facilities used. Agencies that meet the criteria of Practice D 3740 are generally considered capable of competent and objective testing/sampling/inspection/and the like. Users of this

¹ These test methods are under the jurisdiction of ASTM Committee D-18 on Soil and Rock and are the direct responsibility of Subcommittee D18.07 on Identification and Classification of Soils.

Current edition approved Jan. 25, 1985. Published March 1985.

² *Annual Book of ASTM Standards*, Vol 04.08.

³ *Annual Book of ASTM Standards*, Vol 03.03.

*A Summary of Changes section appears at the end of this standard.

method are cautioned that compliance with Practice D 3740 does not in itself assure reliable testing. Reliable testing depends on many factors; Practice D 3740 provides a means of evaluating some of those factors.

5. Apparatus

5.1 *X-Ray Radiography Equipment*—The equipment shall have a minimum output voltage of 100 kV. Equipment with a peak current of approximately 15 mA is needed for a wide range of applications capable of accommodating commercially available film, suitable for the sample sizes to be X-rayed, and suitable for the sample holders. The equipment may be equipped with a fluoroscope.

NOTE 2—Certain types of samples may require equipment capable of performing at lower voltages (for example, 40 kV). In such instances, equipment with lower voltages can be substituted for that required in 5.1. For maximum resolution in certain types of applications a fine-focus X-ray tube may be necessary. Persons inexperienced with X-ray radiography should discuss their specific equipment needs and the requirements of these methods with equipment manufacturers prior to purchasing.

NOTE 3—Equipment with beryllium window X-ray tubes may be necessary to perform radiography at low voltages.

5.2 *Soil Slice Trough*, as shown in Fig. 1 or, other suitable

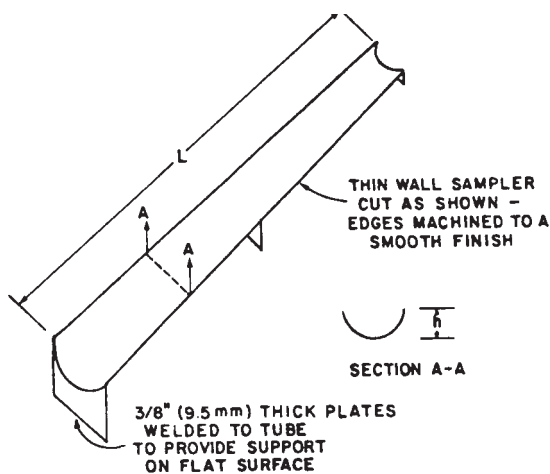

$h = d - \frac{1}{2}$ in. (12.7 mm)
 d = diameter of the sample to be sliced
 L = varies to suit sample length

FIG. 1 Soil Slice Trough and Holder

trough.

5.3 *Extruded Tube Sample Holder*, as shown in Fig. 2, or other suitable holders.

5.4 *Thin Wall Tube Holders*, as shown in Fig. 3, or other suitable holders.

5.5 *Measuring Tape*, minimum 36 in. (914 mm) long.

5.6 *Personal Dosimeters or Film Badges*.

5.7 *Small Hand Tools*, such as wire saws, spatulas, and knives.

5.8 *Industrial Type X-Ray Film*, or equivalent.

5.9 *Intensifying Screens*, made of sheets of thin lead.

5.10 *Alphanumeric Lead Markers*.

6. Safety Precautions

6.1 Radiation safety and policies for the use of X-ray radiography machines applicable to these methods should be

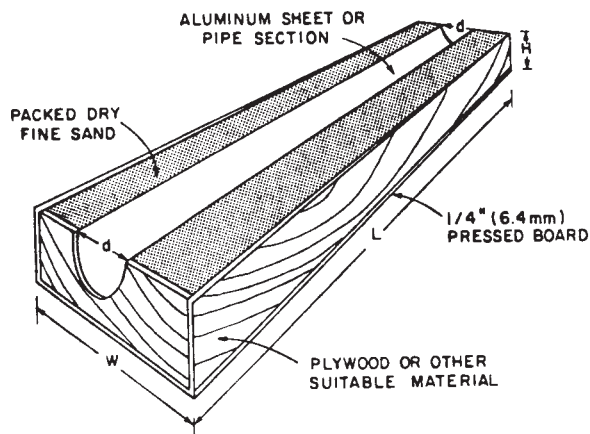

L = variable length to suit the length of the sample
 d = inside diameter of sampling tube used
 $W = d + 2$ in. (51 mm)
 $H = d + 0.25$ in. (6.4 mm)

FIG. 2 Extruded Tube Sample Holder

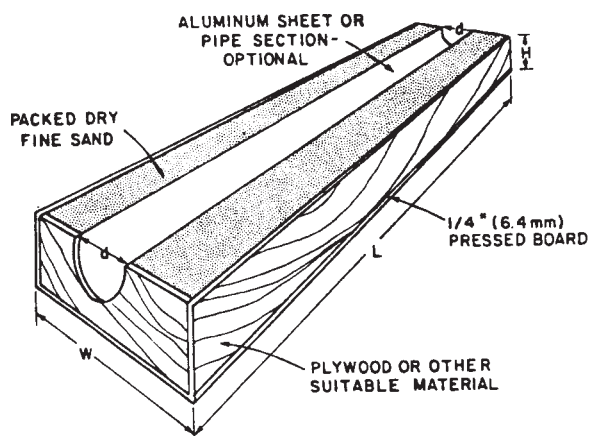

L = variable length to suit the length of sampling tube
 $W = d + 2$ in. (51 mm)
 $H = d + 0.25$ in. (6.4 mm)
 d = outside diameter of sampling tube used

NOTE 1—Aluminum sheet or pipe section is optional. Samples in tubes can be placed in the box and sand can be packed around and under it to conform with the dimensions shown.

FIG. 3 Thin Wall Tube Holder

established based on federal, state, and institutional requirements meeting acceptable radiation safety standards, such as those established by the National Council on Radiation Protection and Measurements (NCRP).⁴

7. Test Method for Tubes and Liners

7.1 *Scope*—This test method can be used to X-ray cores (or observe their features on a fluoroscope) in thin wall tubes or liners ranging from approximately 2 to 6 in. (51 to 152 mm) in diameter. X rays of samples in the larger diameter tubes provide a radiograph of major features of soils and disturbances, such as large scale bending of edges of varved clays, shear planes, the presence of large concretions, silt and sand

⁴ See the National Council on Radiation Protection and Measurements Report No. 33, 1973; Report No. 49, 1976; and Report No. 51, 1977.

seams thicker than ¼ in. (6.4 mm), large lumps of organic matter, and voids or other types of intrusions. X rays of the smaller diameter cores provide higher resolution of soil features and disturbances, such as small concretions (⅛ in. (3.2 mm) diameter or larger), solution channels, slight bending of edges of varved clays, thin silt or sand seams, narrow solution channels, plant root structures, and organic matter. The X-raying of samples in thin wall tubes or liners requires minimal preparation.

7.2 Procedure:

7.2.1 Place the thin wall tube or liner holding the soil sample in the appropriate size sample holder, such as the one shown in Fig. 3. If such a holder is not available, pack the tube sample in sand, clay, or plaster of paris, forming an approximately rectangular cross-section, as shown in Fig. 3.

7.2.2 Load suitable X-ray film. Place the intensifying lead screen in contact with the film.

7.2.3 Position the sample and adjust the equipment so that the distance from the X-ray source to the film provides the best possible radiograph. Experience has shown that a distance of not less than 30 in. (762 mm) is appropriate for most samples. Place the alphanumeric lead identification markers next to, or on, the portion of the sample that was closest to the ground surface in situ that will be included in the X ray. If more than one exposure is required to cover the entire length of the sample, a lead marker should be placed to serve as a match mark.

7.2.4 Adjust the output to a level which will provide the clearest radiograph or fluoroscopic image of the sample. The output is to be determined by the user.

7.2.5 Expose the film an appropriate length of time. Process the exposed film following film developing methods recommended by the manufacturer. The exposure time may vary with equipment, type of soil, or type of tubing material used. It is advisable to experiment with the exposure time, keeping the distance of the specimen from film constant until well-defined, clear, X-ray radiographs are obtained. Adjustments also can be made by keeping the exposure time constant and by varying the distance of the X-ray source from the film.

7.2.6 Rotate the sample 90° about its longitudinal axis and repeat the procedure. Identify the 0° and 90° exposures with lead markers.

7.2.7 For some applications it may be sufficient to prepare samples as in 7.2.1-7.2.3 and simply observe various features on the fluoroscope; in such cases, eliminate 7.2.4.

8. Test Method for Extruded Samples

8.1 Scope:

8.1.1 Greater detail and resolution of various features of the soil can be obtained by X-raying of extruded cores, as compared to samples in metal tubes. The method used for X-raying cores is the same as that for tubes and liners, except that extruded cores have to be handled with extreme care and have to be placed in sample holders (similar to Fig. 2) before X-raying. This method should be used only when natural moisture or other undisturbed soil characteristics are irrelevant to the end use of the sample.

8.1.2 Often it is necessary to obtain greater resolution of features to determine the propriety of sampling methods, the

representative nature of soil samples, or anomalies in soils. This method requires that either duplicate samples be obtained or already tested specimens be X-rayed.

8.2 Specimen Preparation:

8.2.1 Place the specimen horizontally on the soil slicing trough.

8.2.2 Slice the specimen using a clean wire saw or other acceptable cutting device.

8.2.3 Remove the top portion of the specimen by placing a 180° segment of appropriate diameter thin wall tube over the specimen. Turn the thin wall tube segment, the specimen, and the slicing trough upside down in unison, so that the sliced specimen rests in the thin wall tube segment.

8.2.4 Remove the slicing trough and the portion of the specimen contained within. Discard the portion of the specimen removed from the slicing trough.

8.2.5 Wipe the slicing trough clean.

8.2.6 Place the portion of the specimen held in the thin wall tube segment in the trough with the sliced plane facing up.

8.2.7 Repeat 8.2.2.

8.2.8 Place a ¼-in. (6.4-mm) thick window glass or clear acrylic plate over the exposed face of the sample.

8.2.9 Holding the glass plate with one hand and the specimen trough with the other, turn the glass plate, the specimen, and the trough over.

8.2.10 Remove the trough and the portion of the specimen remaining within. This should leave a ⅜-in. (9.5-mm) thick soil slice specimen on the glass plate.

8.3 Procedure:

8.3.1 Load suitable X-ray film. Place the intensifying lead screen in contact with the film.

8.3.2 Position the specimen and glass plate and adjust the distance from the X-ray source to the film to provide the clearest radiograph. Place the alphanumeric lead identification markers on the glass plate next to the specimen.

8.3.3 Repeat 7.2.3 and 7.2.4.

8.3.4 If radiography is not required, see 7.2.7.

9. Interpretation of Test Results

9.1 The interpretation of X-ray radiographs must be done by personnel experienced in analyzing X-ray radiographs of soils.

9.2 X-ray radiographs show variations in the ability of X-rays to penetrate matter. These variations are exhibited as varying shades of gray color burned on the X-ray film.

9.3 The following factors can be discerned from the radiograph:

9.3.1 *Voids*—Open void spaces will show as dark dots, or spaces, or channels, depending on the shape of the void (Fig. 4).

9.3.2 *Bedding*—Horizontal, inclined, or distorted bedding will show as layers of various shades of gray easily identifiable as bedding (Fig. 4).

9.3.3 *Turning of Edges*—Turning or bending of edges of various thin layers show as curved down edges on the sides of the specimen (Fig. 5). In extreme cases this turning down is accompanied by a symmetrical curving of the distorted layers. This may be an indication of improper sampling or extrusion methods (Fig. 6).

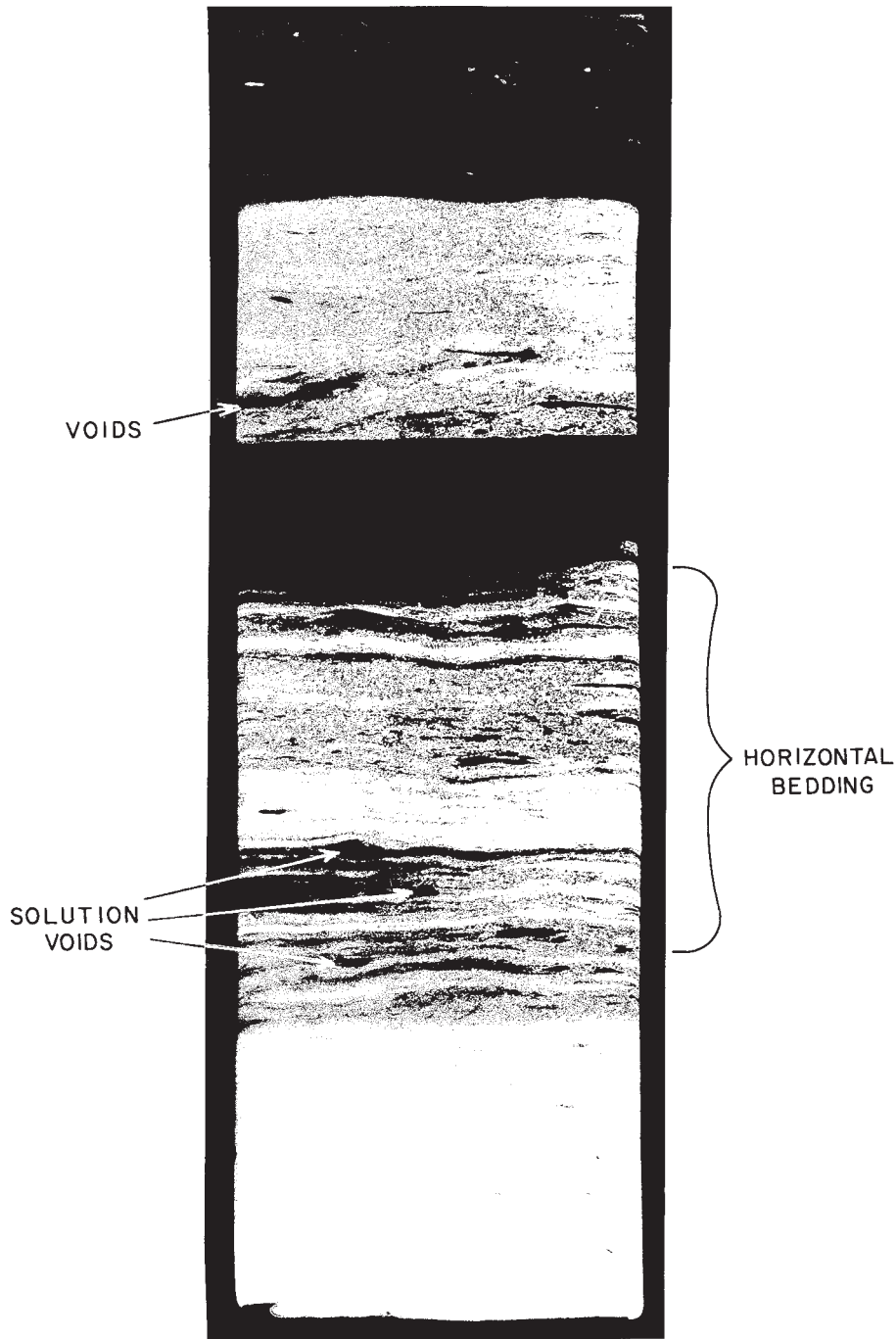

FIG. 4 Open Void Spaces and Bedding

9.3.4 *Peat, Organic Matter, Roots*—Peat and organic matter will appear as dark or black spots (Fig. 7), while roots will appear as black, irregular, often interconnected lines (Fig. 8).

9.3.5 *Shells and Invertebrates*—They will appear as light colored shapes, generally easily identified from their profile (Fig. 9).

9.3.6 *Calcareous Concretions*—These will appear as light gray irregular spots (Fig. 10). Natural fissures will appear as thin dark lines. Where bedding of various layers are apparent in the radiograph, bedding will be continuous across fissures (Fig. 11).

9.3.7 *Shear Fractures*—Shear fractures will appear as either dark lines (open fractures) or as lines identifiable only by the abrupt displacement and discontinuance of a number of bedding planes across the shear zone (Fig. 12).

10. Report

10.1 The report shall include the following (see Fig. X1.1):

10.1.1 Original radiograph, or a negative print, or a contact print of the radiograph,

NOTE 4—When contact prints are used instead of negative prints the

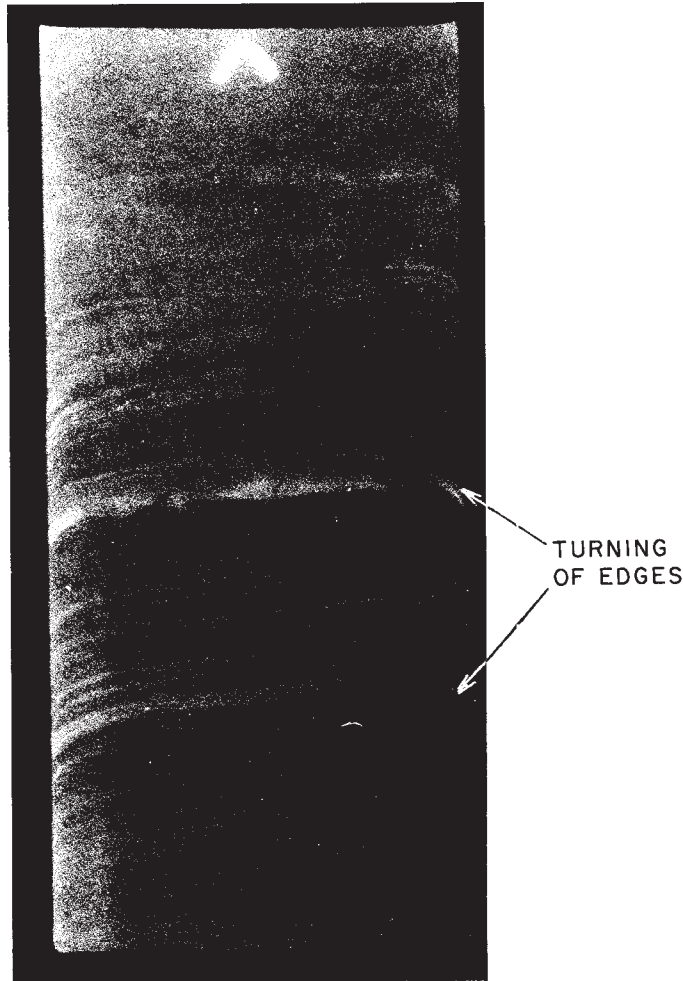

FIG. 5 Turning of Edges

photographic process reverses the colors of the X ray.

10.1.2 Description of the soil specimen,

10.1.3 Location and the depth from which the sample was obtained,

10.1.4 Type and size of sample or specimen used for radiography, (for example, 5 in. (127 mm) diameter sample in thin wall tube),

10.1.5 Type of radiographic equipment used, voltage, amperage, and exposure time,

10.1.6 Distance from the X-ray source to the film surface, and

10.1.7 Descriptive interpretation of the radiograph and its meaning in terms of the quality of the sample.

11. Precision and Bias

11.1 These test methods provide qualitative and general information, therefore, a precision and bias statement is not applicable. The reliability of X ray interpretation of soil samples is commensurate with the training and experience of the personnel.

12. Keywords

12.1 X-rays; sample disturbance; samples; soil investigations; undisturbed samples

EXTREME
DISTURBANCE
OF HORIZONTAL
BEDDING IN
SOFT SOIL



FIG. 6 Extreme Distortion of Bedding in Soft Soil

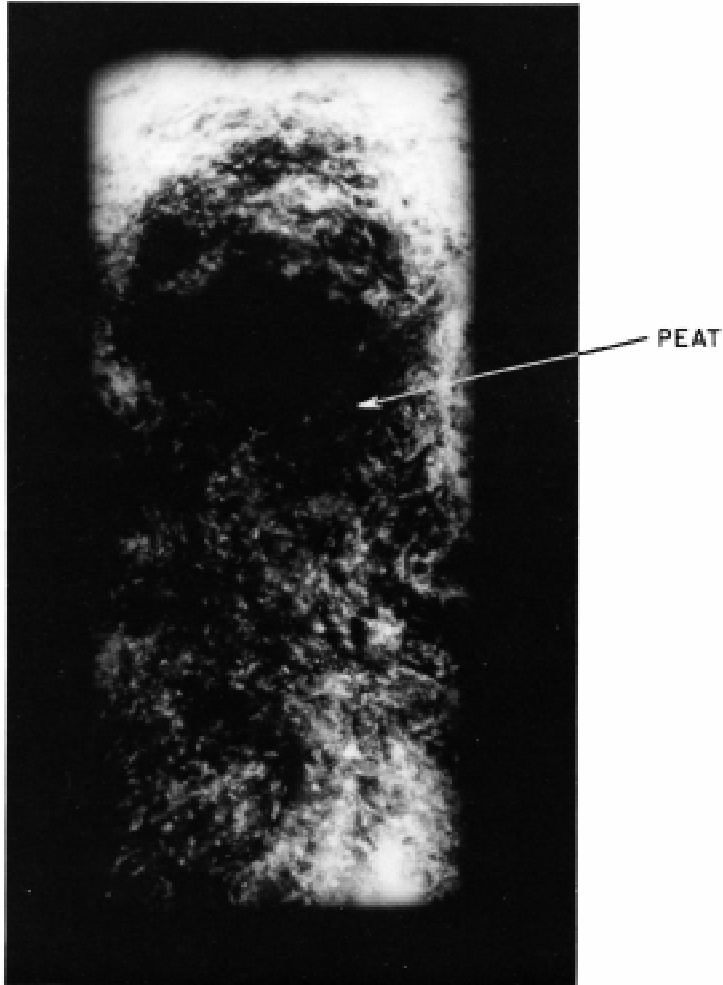

FIG. 7 Appearance of Peat

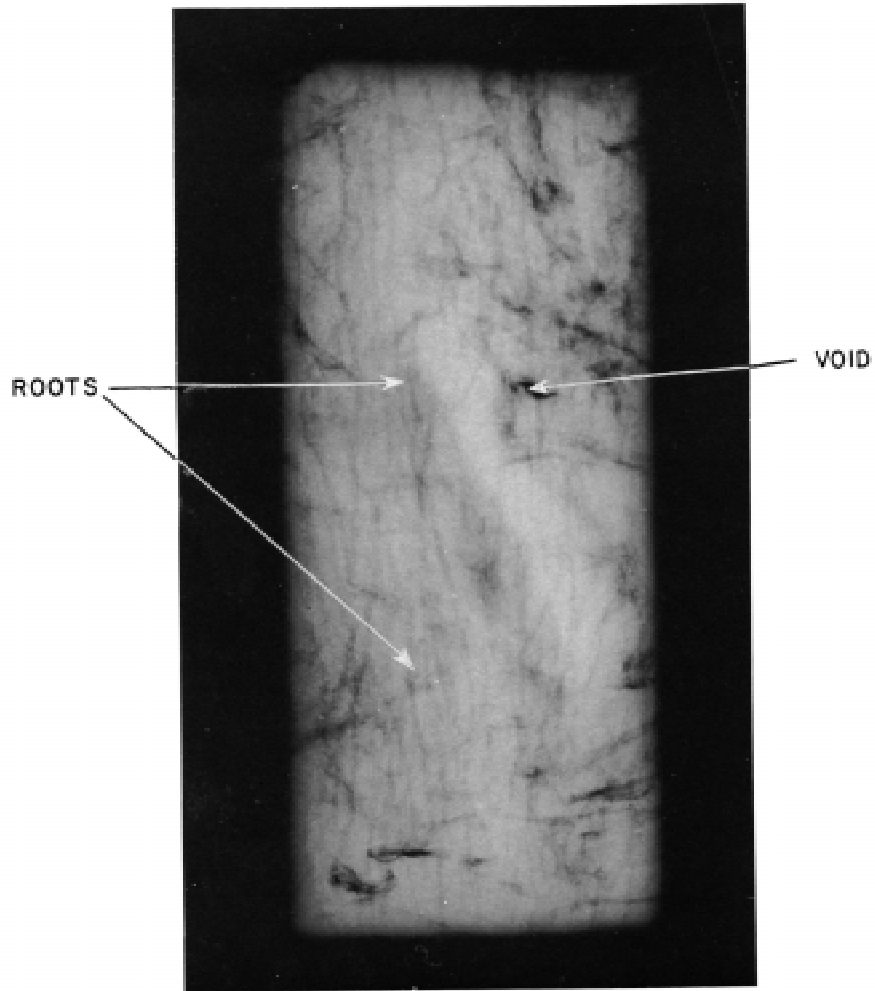

FIG. 8 Appearance of Roots

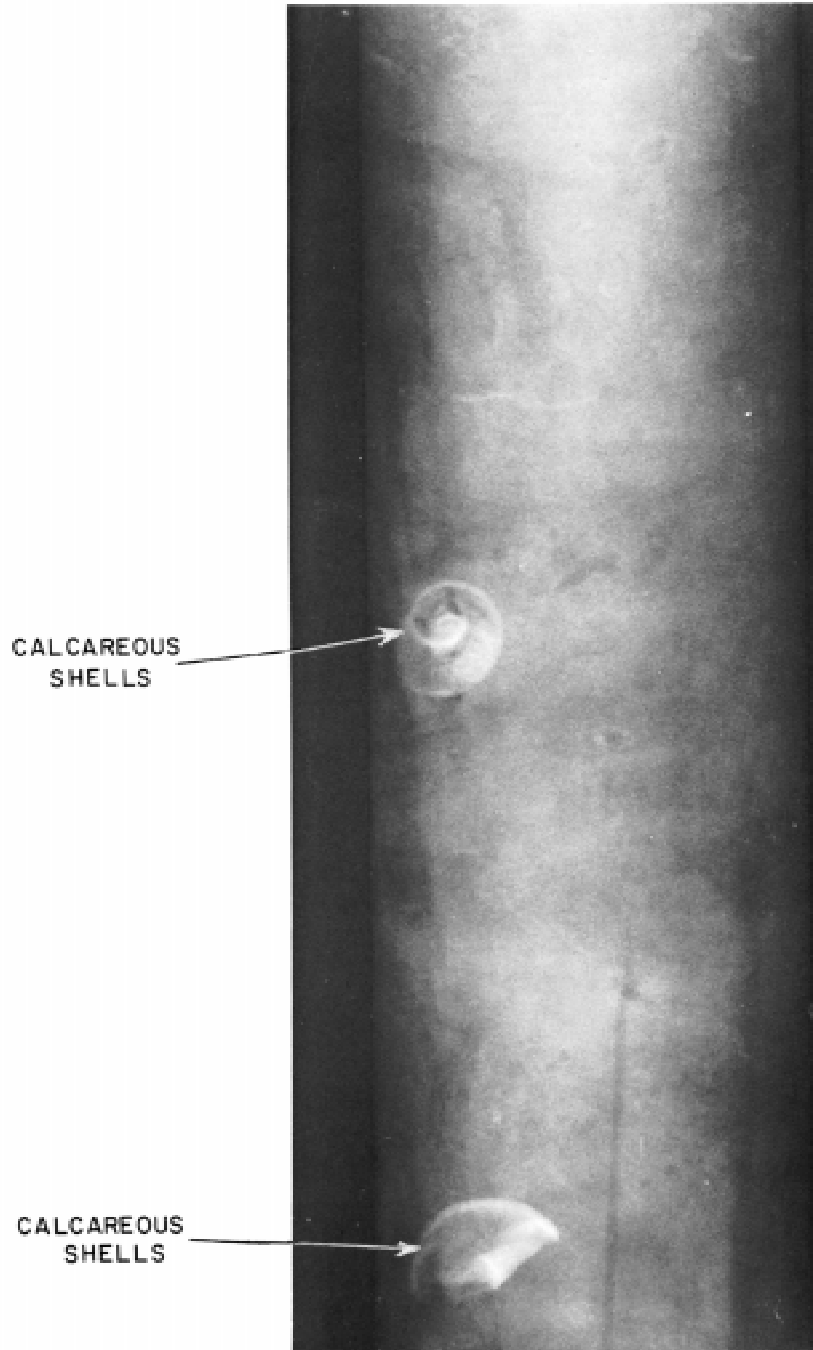

FIG. 9 Shells and Invertebrates

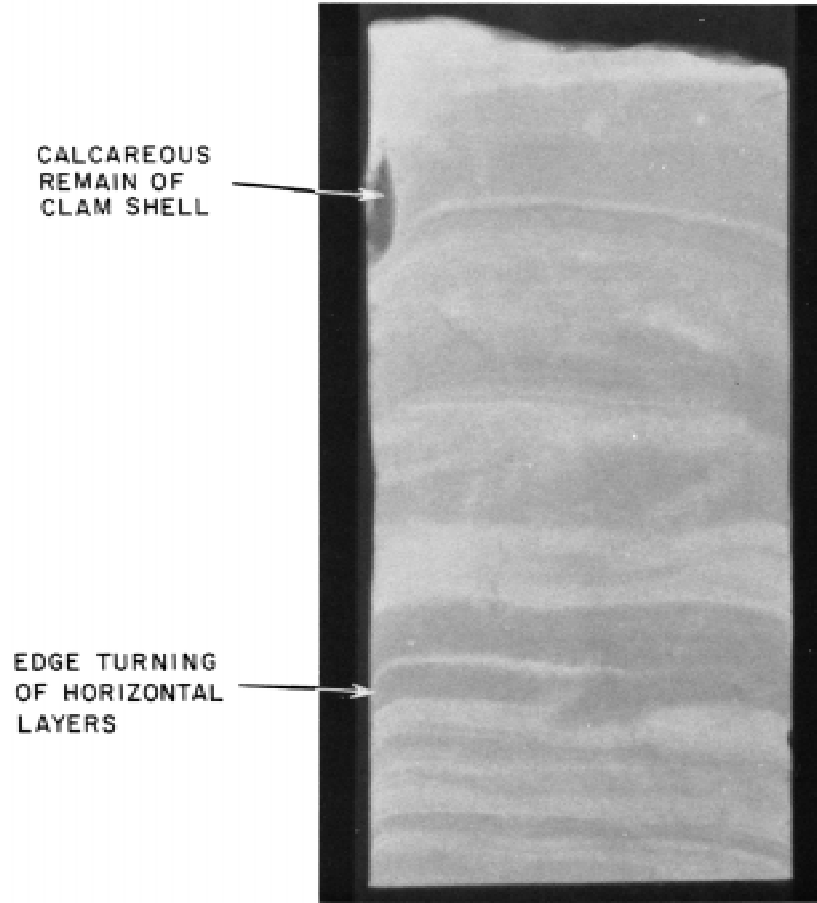

FIG. 10 Calcareous Concretions

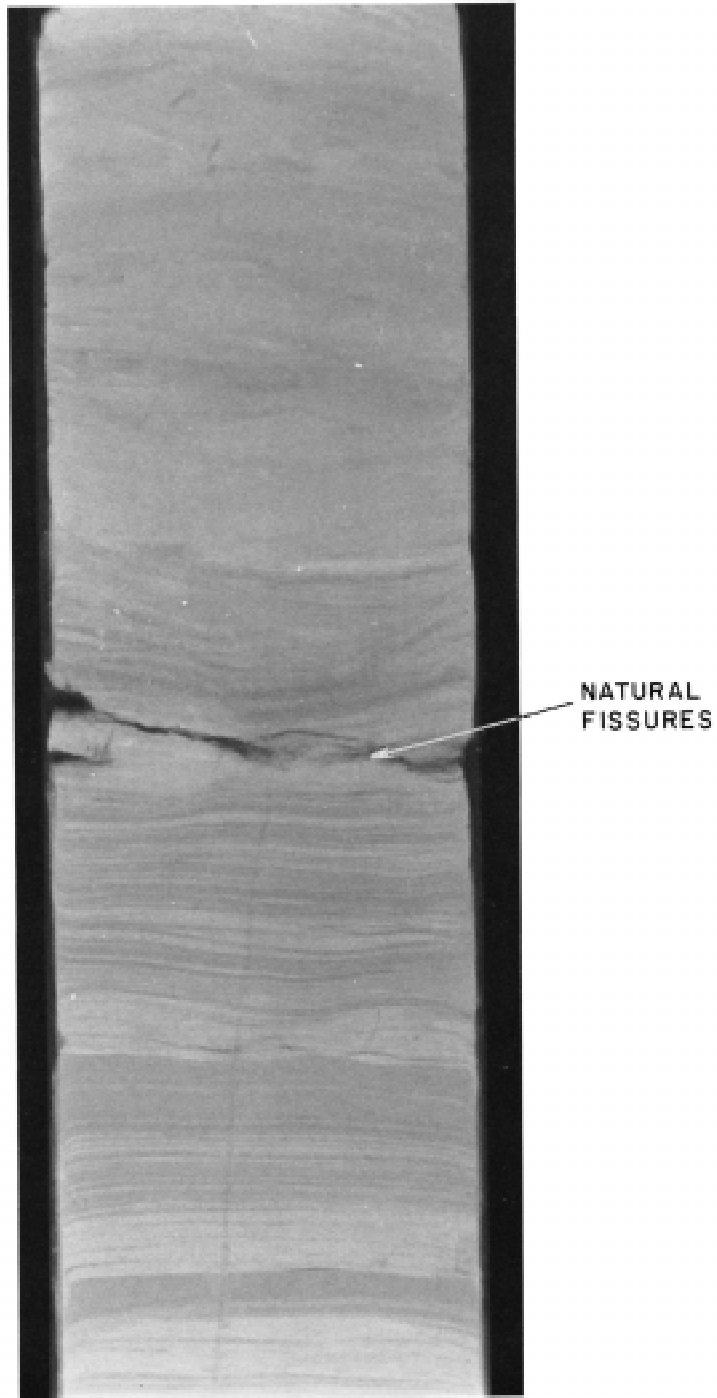

FIG. 11 Bedding Across Fissures

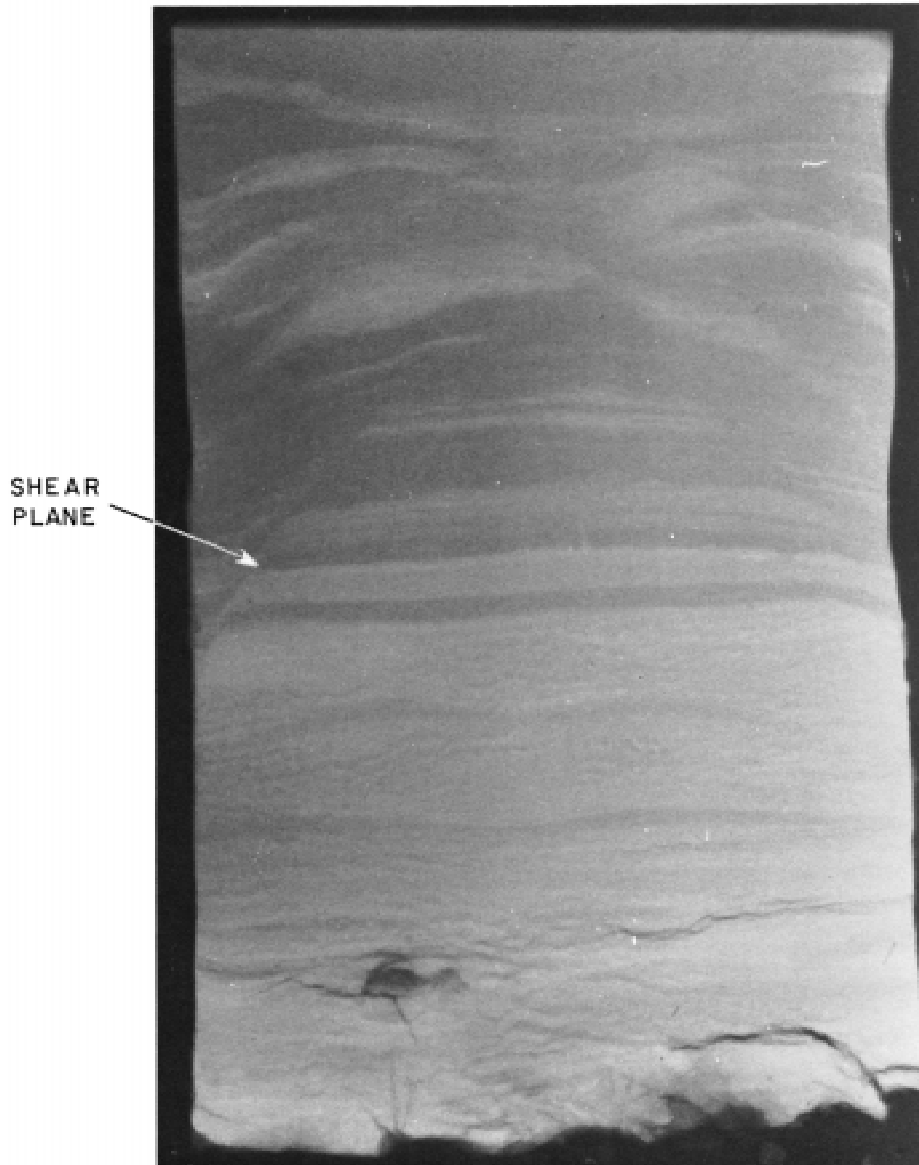

FIG. 12 Shear Fractures

APPENDIX

(Nonmandatory Information)

X1. Sample Report Form

X1.1 See Fig. X1.1.



X-ray Radiograph Report of Soil Specimen

1. Date _____
2. Project No. _____ Project Title _____
3. Project Location _____
4. Sample Obtained by _____
(Method of Sampling)
5. Sample No. _____
6. Depth Sample Taken from _____
7. Description of Soil Type _____
8. Specimen Type _____ (Core in tube, slice, etc.)
9. Specimen Length _____
Specimen Diameter _____
10. Specimen Identification _____
11. Type of Radiographic Equipment Used _____
Tube Type _____
12. Radiation Period _____ Min. Voltage _____
_____ kv.
Amperage _____
13. Distance of Film from Source _____ in.
14. Purpose for Radiography (Sampling Procedures, Anomalies, Etc.):

15. Interpretation of Radiographic Analysis:

16. Attached:
- | | |
|----------------------------------|-----------------------------------|
| (a.) X-ray Radiograph | (c.) Negative Print of Radiograph |
| (b.) Contact Print of Radiograph | (d.) Copy of Radiograph |

FIG. X1.1 Sample Report Format

SUMMARY OF CHANGES

In accordance with Committee D18 policy, this section identifies the location of changes to this standard since the the 1985(Reapproved 1995)e1 edition that may impact the use of this standard.

- (1) Edit grammar and spacing throughout the entire document.
- (2) Added Practice D3740 to Section 2 and Note 1.
- (3) Added Note 1 to Significance and Use and renumbered notes.

 **D 4452 – 85 (2002)^{ε1}**

ASTM International takes no position respecting the validity of any patent rights asserted in connection with any item mentioned in this standard. Users of this standard are expressly advised that determination of the validity of any such patent rights, and the risk of infringement of such rights, are entirely their own responsibility.

This standard is subject to revision at any time by the responsible technical committee and must be reviewed every five years and if not revised, either reapproved or withdrawn. Your comments are invited either for revision of this standard or for additional standards and should be addressed to ASTM International Headquarters. Your comments will receive careful consideration at a meeting of the responsible technical committee, which you may attend. If you feel that your comments have not received a fair hearing you should make your views known to the ASTM Committee on Standards, at the address shown below.

This standard is copyrighted by ASTM International, 100 Barr Harbor Drive, PO Box C700, West Conshohocken, PA 19428-2959, United States. Individual reprints (single or multiple copies) of this standard may be obtained by contacting ASTM at the above address or at 610-832-9585 (phone), 610-832-9555 (fax), or service@astm.org (e-mail); or through the ASTM website (www.astm.org).