

This document is not an ASTM standard and is intended only to provide the user of an ASTM standard an indication of what changes have been made to the previous version. Because it may not be technically possible to adequately depict all changes accurately, ASTM recommends that users consult prior editions as appropriate. In all cases only the current version of the standard as published by ASTM is to be considered the official document.



Designation: D 4543 – 85 (Reapproved 1991)^{e1}



Designation: D 4543 – 01

Standard Practices for Preparing Rock Core Specimens and Determining Dimensional and Shape Tolerances¹

This standard is issued under the fixed designation D 4543; the number immediately following the designation indicates the year of original adoption or, in the case of revision, the year of last revision. A number in parentheses indicates the year of last reapproval. A superscript epsilon (ε) indicates an editorial change since the last revision or reapproval.

^{ε1} ~~NOTE~~ Section 7 was added editorially in December 1991.

¹ This practice is under the jurisdiction of ASTM Committee D18 on Soil and Rock and is the direct responsibility of Subcommittee D18.12 on Rock Mechanics. Current edition approved Nov. 29, 1985; June 10, 2001. Published January 1986; November 2001. Originally published as D 4543-85. Last previous edition D 4543-85 (Reapproved 1991).

1. Scope*

1.1 This practice specifies procedures for determining the length and diameter of rock core specimens and the conformance of the dimensions with established standards.

1.2 Rock is a complex engineering material which can vary greatly as a function of lithology, stress history, weathering, and other natural geologic processes. As such, it is not always possible to obtain or prepare rock core specimens which satisfy the desirable criteria given in this practice. Most commonly, this situation presents itself with weaker, more porous, and poorly cemented rock types and rock types containing significant structural features. For these and other rock types which are difficult to prepare, all reasonable efforts shall be made to prepare a sample in accordance with this practice. However, when it has been determined by trial that this is not possible, prepare the rock specimen to the highest standard practicable and consider this to be the best effort and report it as such, with all appropriate size and dimensional measurements reported as in Section 6.

1.3 This practice also prescribes tolerance checks on the straightness of the elements on the cylindrical surface, the flatness of the end bearing surfaces, and the perpendicularity of the end surfaces with the axis of the core.

1.4 The requirement for specifying the moisture condition of the test specimen at the time of the test is also stated.

1.5 The values stated in inch-pound units are to be regarded as the standard. The SI units given in parentheses are for information only.

1.6 *This standard does not purport to address all of the safety ~~problems~~, concerns, if any, associated with its use. It is the responsibility of the user of this standard to ~~consult and~~ establish appropriate safety and health practices and determine the applicability of regulatory limitations prior to use.*

1.7 *This practice offers a set of instructions for performing one or more specific operations. This document cannot replace education or experience and should be used in conjunction with professional judgement. Not all aspects of this practice may be applicable in all circumstances. This ASTM standard is not intended to represent or replace the standard of care by which the adequacy of a given professional service must be judged, nor should this document be applied without consideration of a project's many unique aspects. The word "standard" in the title of this document means only that the document has been approved through the ASTM consensus process.*

2. Referenced Documents

2.1 *ASTM Standards:*

C 617 Practice for Capping Cylindrical Concrete Specimens²

~~D-2113 Method 2113 Practice for Diamond Rock Core Drilling and Sampling of Rock for Site Investigation³~~

D 2216 Test Method for Laboratory Determination of Water (Moisture) Content of Soil and Rock by Mass³

~~D 2664 Test Method for Triaxial Compressive Strength of Undrained Rock Core Specimens without Pore Pressure Measurements³~~

D 2936 Test Method for Direct Tensile Strength of Intact Rock Core Specimens³

D 2938 Test Method for Unconfined Compressive Strength of Intact Rock Core Specimens³

D 3148 Test Method for Elastic Moduli of Intact Rock Core Specimens in Uniaxial Compression³

~~D-3967 Test Method 3740 Practice for Splitting Tensile Strength Minimum Requirements for Agencies Engaged in the Testing~~

² Annual Book of ASTM Standards, Vol 04.02.

³ Annual Book of ASTM Standards, Vol 04.08.

and/or Inspection of Intact Soil and Rock-Core Specimens³ as Used in Engineering Design and Construction
 D 4341 Test Method for Creep of Cylindrical Hard Rock Core Specimens in Uniaxial Compression³
 D 4405 Test Method for Creep of Cylindrical Soft Rock Core Specimens in Uniaxial Compression³
 D 4406 Test Method for Creep of Cylindrical Rock Core Specimens in Triaxial Compression³

3. Significance and Use

3.1 The dimensional, shape, and surface tolerances of rock core specimens are important for determining rock properties of intact specimens. Dimensional and surface tolerance checks are required in the test methods listed in 2.1. To simplify test procedures in laboratories, the parts of those procedures that are common to the test methods are given in this standard.

4. Specimens

- 4.1 Test specimens shall be right circular cylinders within the tolerances specified herein.
- 4.2 The specimen shall have a length-to-diameter ratio (L/D) of 2.0 to 2.5 and a diameter of not less than 1 7/8 in. (47 mm).

NOTE 1—It is desirable that the diameter of rock test specimens be at least ten times the diameter of the largest mineral grain. For weak rock types which behave more like soil (for example, weakly cemented sandstone), the specimen diameter should be at least six times the maximum particle diameter. It is considered that the specified minimum specimen diameter of approximately 1 7/8 in. (47 mm) will satisfy this criterion in the majority of cases. When cores of diameter smaller than the specified minimum must be tested because of the unavailability of larger diameter core, as is often the case in the mining industry, suitable notation of this fact shall be made in the report.

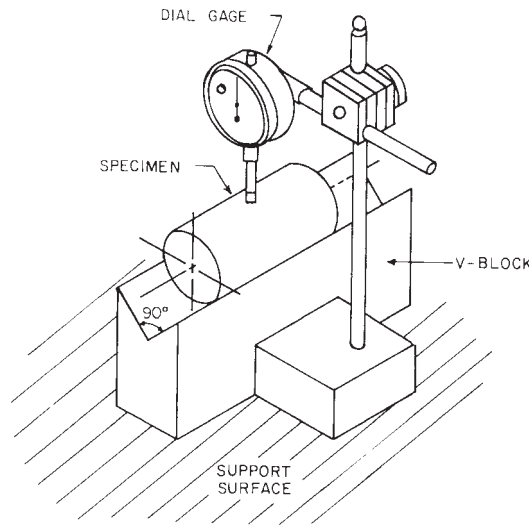

FIG. 1 Assembly for Determining the Straightness of Elements on the Cylindrical Surface—Procedure B

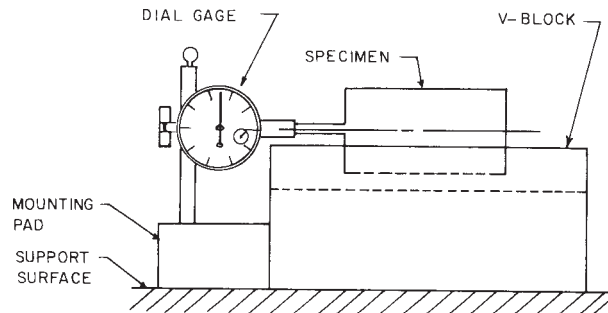

FIG. 2 Assembly for Determining the Flatness and Perpendicularity of End Surfaces to the Specimen Axis—Procedure B

4.3 The sides of the specimen shall be generally smooth and free of abrupt irregularities, with all the elements straight to within 0.020 in. (0.50 mm) over the full length of the specimen, as determined by 5.1.

4.4 The ends of the specimen shall be cut parallel to each other and at right angles to the longitudinal axis. The end surfaces

shall be surface ground or lapped flat to a tolerance not to exceed 0.001 in. (25 μm), as determined by 5.2.⁴

5. Procedure

5.1 Determine the deviation from straightness of the elements by either Procedure A or Procedure B, as follows:

5.1.1 *Procedure A*—Roll the cylindrical specimen on a smooth, flat surface and measure the height of the maximum gap between the specimen and the flat surface with a feeler gage. If the maximum gap exceeds 0.020 in. (0.50 mm), the specimen does not meet the required tolerance for straightness of the elements. The flat test surface on which the specimen is rolled shall not depart from a plane by more than 0.0005 in. (13 μm).

5.1.2 *Procedure B*—Place the cylindrical surface of the specimen on a V-block that is laid flat on a support surface. The V-block shall be machinist quality with all bearing faces surface ground and with a 90° included angle. Maintain the support surface and all bearing surfaces on the V-block flat and smooth to within 0.0005 in. (13 μm). The length of the V-block shall be sufficient that the specimen will not project over its ends during movement.

5.1.2.1 Place a dial gage in contact with the top of the specimen, as shown in Fig. 1, and observe the dial reading as the specimen is moved from one end of the V-block to the other along a straight line, without rotation. The sensitivity of the dial gage shall be at least 0.001 in. (25 μm). The measurement contact tip of the dial gage shall be round in shape.

5.1.2.2 Record the maximum and minimum readings on the dial gage and calculate the difference, Δ₀. If the dial gage traverses a natural cavity in the rock, readings in this region should not be included in the determination of Δ₀. Repeat the same operations by rotating the specimen for every 120°, and obtain the differences Δ₁₂₀ and Δ₂₄₀. The maximum value of these three differences shall be less than 0.020 in. (0.50 mm).

5.2 Check the end flatness tolerance by either Procedure A or Procedure B, as follows:

5.2.1 *Procedure A*—Place the specimen in a setup similar to that for the cylindrical surface (Fig. 2) except that the dial gage shall be mounted near the end of the V-block.

5.2.1.1 Move the mounting pad horizontally so that the dial gage measurement tip runs across a diameter of the specimen end surface. Take care to make sure that one end of the mounting pad maintains intimate contact with the end surface of the V-block during movement. A dial gage sensitive readable to 0.0001 in. (2.5 μm) is required for measurements on the end surfaces.

5.2.1.2 Record the dial gage readings every 1/8 in. (3 mm) across the diameter. These readings may be recorded in tabular form, or to simplify the procedure, they may be plotted directly on a graph as shown for End 1, Diameter 1, in Fig. 3. Data recording is also simplified if the dial gage is set to zero when it is in contact with the center of the end face.

5.2.2.1.3 Plot the readings and draw a smooth curve through the points to represent the surface profile along the specified diametrical plane, as shown for End 1, Diameter 1, in Fig. 3. Do not plot dial gage readings taken when the gage tip drops into a natural cavity in the rock. The flatness tolerance is met when the smooth curve so determined does not depart from a visual best-fit straight line by more than 0.001 in. (25 μm).

5.2.3.1.4 Rotate the specimen 90° about its longitudinal axis and repeat the same operations and tolerance checks for the new diametrical plane. Turn the specimen end for end and repeat the same measurement procedures and tolerance checks for the other end surface.

⁴ Hoskins, J. R., and Horino, F. G., "Effects of End Conditions on Determining Compressive Strength of Rock Samples," *Report of Investigations U.S. Bureau of Mines 7171*, 1968.

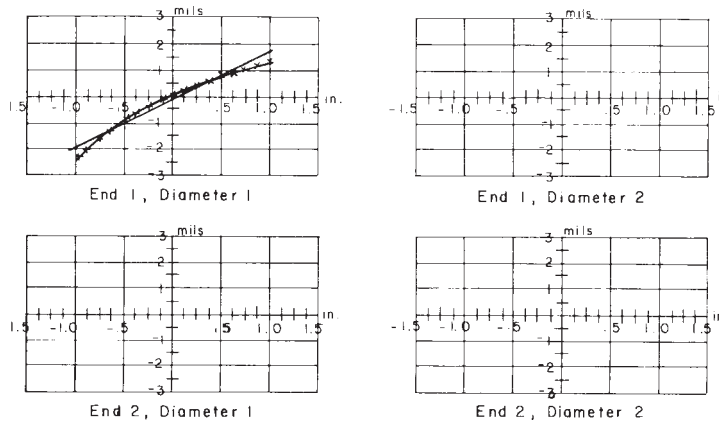

Difference between maximum and minimum readings for Diam 1, End 1 = Δ₁ = _____
 Difference for Diam 2, End 1 = Δ₂ = _____
 Difference for Diam 1, End 2 = Δ₁' = _____
 Difference for Diam 2, End 2 = Δ₂' = _____
 Use the largest of the four Δ, Δ_{max} = _____

Perpendicularity tolerance is met when $\frac{\Delta_{max}}{diam} \leq 0.0043$

FIG. 3 Suggested Format for Presenting Tolerance-Check Data

5.2.2 Procedure B—Set the specimen upright on a smooth, flat surface that does not depart from plane by more than 0.0005 in (13 μm).

5.2.2.1 Place a dial gage measurement tip in contact with the top of the specimen. The readability of the dial gage shall be at least 0.0001 in (2.5 μm).

5.2.2.2 Move the dial gage measurement tip across the top of the specimen along at least three different diameters. Note the maximum and minimum dial gage readings. Do not include dial gage readings taken when the measurement tip drops into a natural cavity in the rock. Turn the specimen end-for-end and repeat.

5.2.2.3 The flatness tolerance is met if the difference between the maximum and minimum readings is less than 0.0015 in. (38 μm). This procedure also ensures that the ends of the specimen are parallel.

5.3 The ends of the specimen shall not depart from perpendicularity to the axis of the specimen by more than 0.25°, which is a slope of 1 part in 230.^{4,5} Check this tolerance using either Procedure A or Procedure B, as follows:

5.3.1 Procedure A—Use the measurements taken in 5.2.1. Calculate the difference between the maximum and the minimum readings on the dial gage along Diameter 1. This difference is denoted as Δ₁. Calculate the corresponding difference for Diameter 2, which is 90° from Diameter 1. Denote the difference for Diameter 2 as Δ₂. Calculate the corresponding differences for the other end of the specimen, Δ₁[⊥] and Δ₂[⊥]. The perpendicularity tolerance will be considered to have been met when:

$$\frac{\Delta_i}{d} \text{ and } \frac{\Delta'_i}{d} \leq \frac{1}{230} = 0.0043 \quad (1)$$

where:

i = 1 or 2, and

d = diameter.

5.3.2 Procedure B—Set the specimen upright on a smooth, flat surface that does not depart from plane by more than 0.0005 in. (13 μm).

5.3.2.1 Place the base of a true square on the test surface and in contact with the bottom of the specimen.

5.3.2.2 Rotate the specimen, keeping contact with the square, until the maximum gap between the square and the top of the specimen is found. Determine the width of the gap using a feeler gage.

5.3.2.3 The perpendicularity tolerance is met if the gap, Δ, divided by the specimen length, *L*, is less than 1 part in 230, i.e.,

$$\frac{\Delta}{L} \leq \frac{1}{230} = 0.0043 \quad (2)$$

5.3.2.4 Repeat for other end of specimen unless the specimen ends were checked for parallelism in 5.2.2.

5.4 The measurements described in 5.1.2, 5.2, and 5.3 are taken with a mechanical dial gage. An optical or electronic device with an equivalent or better readout sensitivity and accuracy may be used in place of the dial gage, if desired.

5.5 The measurements taken on the ends of the specimen in 5.2.1 and 5.3.1 may also be made with the specimen clamped upright in a machinist quality V-block. The measuring tip of the dial gage would then contact the upper end surface of the specimen. Either the V-block and specimen may be moved as a unit under a stationary dial gage, or the dial gage may be moved while the V-block and specimen remain stationary. Whatever configuration is assembled, it must be machinist quality so that readings may be reproduced within 0.0001 in. (2.5 μm). The readings to be taken with such a vertical configuration are the same as those specified for the horizontal configuration in 5.2.1 and 5.3.1.

5.6 Determine the diameter of the test specimen to the nearest 0.01 in. (0.25 mm) by averaging two diameters measured at right angles to each other at about midheight of the specimen. Use this average diameter for calculating the cross-sectional area. Determine the length of the test specimen to the nearest 0.01 in. (0.25 mm) at the centers of the end faces.

5.7 The use of capping materials or end surface treatments other than the grinding and lapping specified herein is not permitted, except as noted in 5.8. Lubricants are not permitted on the specimen - platen interfaces.

5.8 There are some rock types with physical characteristics or low strengths which preclude preparing specimens to the flatness tolerance specified in 5.2, even with the best effort (Note 2). In these instances, first cut to length the core specimen and apply end caps to the end surfaces of the specimen.

5.8.1 The specifications for the capping compound, capping plates, and alignment devices and the procedure for capping weak rock core specimens shall be the same as those established for compression testing of concrete in Practice C 617; however, melted sulfur capping compounds are not permitted because of the possible detrimental effects of the high temperature on the rock.

NOTE 2—Best effort in surface preparation refers to the use of a well-maintained surface grinder by an experienced operator. Air-cooled grinding with a dust collector is recommended over water circulation for weak rocks and rocks that may react to fluids. A diamond grinding wheel may help if there are hard mineral grains in the rock, such as pyrite in shale.

5.9 The moisture condition of the ~~sample~~ specimen shall be determinoed using Test Method D 2216 and reported as required

⁵ Podnieks, E. R., Chamberlain, P. G., and Thill, R. E., "Environmental Effects on Rock Properties," *Basic and Applied Rock Mechanics, Proceedings of Tenth Symposium on Rock Mechanics*, AIME, 1972, pp. 215–241.

in 6.1.6. Until an ASTM method is developed to determine moisture condition, the use of International Society for Rock Mechanics standards is suggested.⁶ 6.1.6.

NOTE 3—The moisture condition of the specimen at the time of the sample preparation can have a significant effect upon the strength and deformation characteristics of the rock. Good practice generally dictates that laboratory tests be made upon specimens representative of field conditions. Thus, it follows that the field moisture condition of the specimen should be preserved until the time of the test. In some instances, however, there may be reasons for testing specimens at other moisture contents, from saturation to dry. In any case, the moisture content of the test specimen should be tailored to the problem at hand. Excess moisture will affect the adhesion of resistance strain gages, if used, and the accuracy of their performance. Adhesives used to bond the rock to steel end pieces in the direct tension test will also be affected adversely by excess moisture.

6. Report

6.1 Report the following along with other data required for the particular test (2.1) being performed:

6.1.1 Source of test specimen, including project name and location. Often the location is specified in terms of the drill hole number and depth of specimen from collar of hole.

6.1.2 Date test is performed.

6.1.3 Physical description of test specimen including: rock type such as sandstone, limestone, granite, etc.; location and orientation of inherent rock structural features and any discontinuities; and large inclusions or inhomogeneities, if any. A sketch of the test specimen is recommended for other than homogeneous rock types.

6.1.4 Specimen diameter and length, and conformance or best effort conformance with dimensional requirements (4.2 and 5.6).

6.1.5 Data to substantiate the following three tolerances:

6.1.5.1 Straightness of elements by either Procedure A (5.1.1) or Procedure B (5.1.2).

6.1.5.2 Flatness of end faces by either Procedure A (5.1.1) or Procedure B (5.1.2).

6.1.5.3 Perpendicularity of end faces by either Procedure A (5.3.1) or Procedure B (5.3.2).

6.1.6 General indication of the moisture condition of the sample at the time of the test, such as as-received, saturated, laboratory air-dry, or oven dry. It is recommended that the moisture conditions be more precisely determined when possible and reported as either water content or degree of saturation.

7. Keywords

7.1 conformance; core; diameter; dimensional tolerances; dimensions; length; rock; specimen preparation (for testing); specimen shape; specimen size

SUMMARY OF CHANGES

(1) In title, “Practice” was changed to “Practices.”

(2) In the Scope, added caveat required for practices.

(3) In Referenced Documents, added D 2216 Method for Determination of Water (Moisture) Content of Soil and Rock

(4) In Referenced Documents, added D 3740 Practice for Minimum Requirements for Agencies Engaged in the Testing and/or Inspection of Soil and Rock as Used in Engineering Design and Construction

(5) In Referenced Documents, deleted D 3967 Test Method for Splitting Tensile Strength of Intact Rock Core Specimens

(6) In Procedure, minor corrections were made to some of the metric conversions.

(7) In Procedure, a procedure B was added to sections 5.2 and 5.3, which dealt with end flatness and perpendicularity. This was to include a procedure, which has been historically used by a large number of test laboratories where one end of the cylindrical surface is placed on a flat surface while the other end is checked with a dial gage, or similar device.

(8) In Procedure, An ASTM test method for determining water content, which did not previously exist, was added to the procedure. The reference to a International Society for Rock Mechanics; Suggested Method, which had been used to cover the previous deficiency, was removed since it was no longer needed.

(9) In Keywords, deleted: surface analysis and tolerances.

(10) In Keywords, added: core, specimen shape, specimen size, and dimensional tolerances.

ASTM International takes no position respecting the validity of any patent rights asserted in connection with any item mentioned in this standard. Users of this standard are expressly advised that determination of the validity of any such patent rights, and the risk of infringement of such rights, are entirely their own responsibility.

This standard is subject to revision at any time by the responsible technical committee and must be reviewed every five years and if not revised, either reapproved or withdrawn. Your comments are invited either for revision of this standard or for additional standards and should be addressed to ASTM International Headquarters. Your comments will receive careful consideration at a meeting of the responsible technical committee, which you may attend. If you feel that your comments have not received a fair hearing you should make your views known to the ASTM Committee on Standards, at the address shown below.

 **D 4543 – 01**

This standard is copyrighted by ASTM International, 100 Barr Harbor Drive, PO Box C700, West Conshohocken, PA 19428-2959, United States. Individual reprints (single or multiple copies) of this standard may be obtained by contacting ASTM at the above address or at 610-832-9585 (phone), 610-832-9555 (fax), or service@astm.org (e-mail); or through the ASTM website (www.astm.org).