



Designation: D 4767 – 9502

Standard Test Method for Consolidated Undrained Triaxial Compression Test for Cohesive Soils¹

This standard is issued under the fixed designation D 4767; the number immediately following the designation indicates the year of original adoption or, in the case of revision, the year of last revision. A number in parentheses indicates the year of last reapproval. A superscript epsilon (ϵ) indicates an editorial change since the last revision or reapproval.

¹ This test method is under the jurisdiction of ASTM Committee D18 on Soil and Rock and is the direct responsibility of Subcommittee D18.05 on Strength and Compressibility of Soils.

Current edition approved Dec. 10, 1995; 2002. Published April 1996. January 2003. Originally published as D 4767 – 88 ϵ^1 , approved in 1988. Last previous edition D 4767 – 88 ϵ^1 , approved in 1995 as as D 4767 – 95.

1. Scope *

1.1 This test method covers the determination of strength and stress-strain relationships of a cylindrical specimen of either an undisturbed or remolded saturated cohesive soil. Specimens are isotropically consolidated and sheared in compression without drainage at a constant rate of axial deformation (strain controlled).

1.2 This test method provides for the calculation of total and effective stresses, and axial compression by measurement of axial load, axial deformation, and pore-water pressure.

1.3 This test method provides data useful in determining strength and deformation properties of cohesive soils such as Mohr strength envelopes and Young's modulus. Generally, three specimens are tested at different effective consolidation stresses to define a strength envelope.

1.4 The determination of strength envelopes and the development of relationships to aid in interpreting and evaluating test results are beyond the scope of this test method and must be performed by a qualified, experienced professional.

1.5 All observed and calculated values shall conform to the guidelines for significant digits and rounding established in Practice D 6026.

1.5.1 The method used to specify how data are collected, calculated, or recorded in this standard is not directly related to the accuracy to which the data can be applied in design or other uses, or both. How one applies the results obtained using this standard is beyond its scope.

1.6 The values stated in SI units shall be regarded as the standard. The values stated in inch-pound units are approximate.

~~1.6 This standard may involve hazardous materials, operations, and equipment.~~

1.7 This standard does not purport to address all of the safety concerns, if any, associated with its use. It is the responsibility of the user of this standard to establish appropriate safety and health practices and determine the applicability of regulatory limitations prior to use.

2. Referenced Documents

2.1 ASTM Standards:

D 422 Method for Particle-Size Analysis of Soils²

D 653 Terminology Relating to Soil, Rock, and Contained Fluids²

D 854 Test Method for Specific Gravity of Soils²

D 1587 Practice for Thin-Walled Tube Sampling of Soils²

D 2166 Test Method for Unconfined Compressive Strength of Cohesive Soil²

D 2216 Method for Laboratory Determination of Water (Moisture) Content of Soil, Rock, and Soil-Aggregate Mixtures²

D 2435 Test Method for One-Dimensional Consolidation Properties of Soils²

~~D 2487 Test Method for Classification of Soils for Engineering Purposes²~~

~~D 2850 Test 2850 Test Method for Unconsolidated, Undrained Compressive Strength of Cohesive Soils in Triaxial Compression²~~

D 3740 Practice for Minimum Requirements for Agencies Engaged in the Testing and/or Inspection of Soil and Rock as Used in Engineering Design and Construction²

D 4220 Practices for Preserving and Transporting Soil Samples²

² Annual Book of ASTM Standards, Vol 04.08.

*A Summary of Changes section appears at the end of this standard.

D 4318 Test Method for Liquid Limit, Plastic Limit, and Plasticity Index of Soils²

D 4753 Specification for Evaluating, Selecting, and Specifying Balances and Scales for Use in Soil and Rock Testing²

D 6026 Practice for Using Significant Digits in Geotechnical Data³

3. Terminology

3.1 *Definitions*—The definitions of terms used in this test method shall be in accordance with Terminology D 653.

3.2 *Definitions of Terms Specific to This Standard:*

3.2.1 *back pressure*—a pressure applied to the specimen pore-water to cause air in the pore space to compress and to pass into solution in the pore-water thereby increasing the percent saturation of the specimen.

3.2.2 *effective consolidation stress*—the difference between the cell pressure and the pore-water pressure prior to shearing the specimen.

3.2.3 *failure*—the stress condition at failure for a test specimen. Failure is often taken to correspond to the maximum principal stress difference (maximum deviator stress) attained or the principal stress difference (deviator stress) at 15 % axial strain, whichever is obtained first during the performance of a test. Depending on soil behavior and field application, other suitable failure criteria may be defined, such as maximum effective stress obliquity, σ'_1/σ'_3 , or the principal stress difference (deviator stress) at a selected axial strain other than 15 %.

4. Significance and Use

4.1 The shear strength of a saturated soil in triaxial compression depends on the stresses applied, time of consolidation, strain rate, and the stress history experienced by the soil.

4.2 In this test method, the shear characteristics are measured under undrained conditions and is applicable to field conditions where soils that have been fully consolidated under one set of stresses are subjected to a change in stress without time for further consolidation to take place (undrained condition), and the field stress conditions are similar to those in the test method.

NOTE 1—If the strength is required for the case where the soil is not consolidated during testing prior to shear, refer to Test Method D 2850 or Test Method D 2166.

4.3 Using the pore-water pressure measured during the test, the shear strength determined from this test method can be expressed in terms of effective stress. This shear strength may be applied to field conditions where full drainage can occur (drained conditions) or where pore pressures induced by loading can be estimated, and the field stress conditions are similar to those in the test method.

4.4 The shear strength determined from the test expressed in terms of total stresses (undrained conditions) or effective stresses (drained conditions) is commonly used in embankment stability analyses, earth pressure calculations, and foundation design.

NOTE 2—Notwithstanding the statements on precision and bias contained in this test method. The precision of this test method is dependent on the competence of the personnel performing it and the suitability of the equipment and facilities used. Agencies which meet the criteria of Practice D 3740 are generally considered capable of competent testing. Users of this test method are cautioned that compliance with Practice D 3740 does not ensure reliable testing. Reliable testing depends on several factors; Practice D 3740 provides a means of evaluating some of those factors.

5. Apparatus

5.1 The requirements for equipment needed to perform satisfactory tests are given in the following sections. See Fig. 1 and Fig. 2

5.2 *Axial Loading Device*—The axial loading device ~~may~~ shall be a screw jack driven by an electric motor through a geared transmission, a hydraulic loading device, or any other compression device with sufficient capacity and control to provide the rate of axial strain (loading) prescribed in 8.4.2. The rate of advance of the loading device ~~should~~ shall not deviate by more than ± 1 % from the selected value. Vibration due to the operation of the loading device shall be sufficiently small to not cause dimensional changes in the specimen or to produce changes in pore-water pressure when the drainage valves are closed.

NOTE 3—A loading device may be judged to produce sufficiently small vibrations if there are no visible ripples in a glass of water placed on the loading platform when the device is operating at the speed at which the test is performed.

5.3 *Axial Load-Measuring Device*—The axial load-measuring device shall be a load ring, electronic load cell, hydraulic load cell, or any other load-measuring device capable of the accuracy prescribed in this paragraph and may be a part of the axial loading device. The axial load-measuring device shall be capable of measuring the axial load to an accuracy of within 1 % of the axial load at failure. If the load-measuring device is located inside the triaxial compression chamber, it shall be insensitive to horizontal forces and to the magnitude of the chamber pressure.

5.4 *Triaxial Compression Chamber*—The triaxial chamber shall have a working chamber pressure equal to the sum of the effective consolidation stress and the back pressure. It shall consist of a top plate and a base plate separated by a cylinder. The cylinder may be constructed of any material capable of withstanding the applied pressures. It is desirable to use a transparent material or have a cylinder provided with viewing ports so the behavior of the specimen may be observed. The top plate shall have

³ Annual Book of ASTM Standards, Vol 04.09.

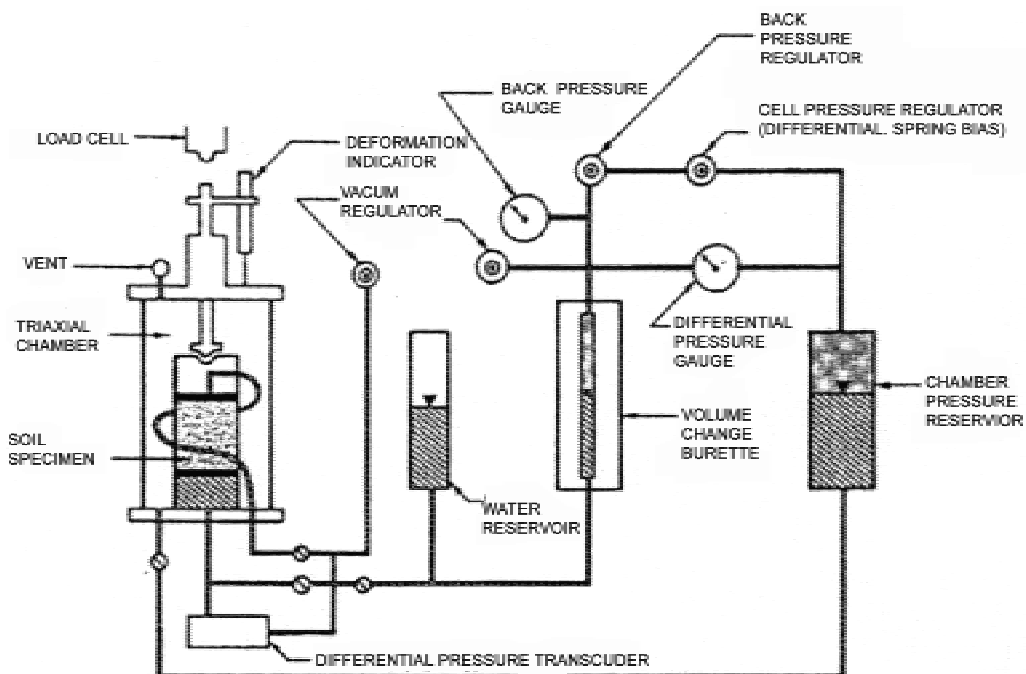

FIG. 1 Schematic Diagram of a Typical Consolidated Undrained Triaxial Apparatus

a vent valve such that air can be forced out of the chamber as it is filled. The baseplate shall have an inlet through which the pressure liquid is supplied to the chamber, and inlets leading to the specimen base and provide for connection to the cap to allow saturation and drainage of the specimen when required.

5.5 *Axial Load Piston*—The piston passing through the top of the chamber and its seal must be designed so the variation in axial load due to friction does not exceed 0.1 % of the axial load at failure and so there is negligible lateral bending of the piston during loading.

NOTE 4—The use of two linear ball bushings to guide the piston is recommended to minimize friction and maintain alignment.

NOTE 5—A minimum piston diameter of 1/6 the specimen diameter has been used successfully in many laboratories to minimize lateral bending.

5.6 *Pressure and Vacuum-Control Devices*—The chamber pressure and back pressure control devices shall be capable of applying and controlling pressures to within ± 2 kPa (0.25 lb/in.²) for effective consolidation pressures less than 200 kPa (28 lb/in.²) and to within ± 1 % for effective consolidation pressures greater than 200 kPa. The vacuum-control device shall be capable of applying and controlling partial vacuums to within ± 2 kPa. The devices may shall consist of self-compensating mercury pots, pneumatic pressure regulators, combination pneumatic pressure and vacuum regulators, or any other device capable of applying and controlling pressures or partial vacuums to the required tolerances. These tests can require a test duration of several days, therefore, an air/water interface is not recommended for either the chamber pressure or back pressure systems.

5.7 *Pressure- and Vacuum-Measurement Devices*—The chamber pressure-, back pressure-, and vacuum-measuring devices shall be capable of measuring pressures or partial vacuums to the tolerances given in 5.6. They may consist of Bourdon gages, pressure manometers, electronic pressure transducers, or any other device capable of measuring pressures, or partial vacuums to the stated tolerances. If separate devices are used to measure the chamber pressure and back pressure, the devices must be calibrated simultaneously and against the same pressure source. Since the chamber and back pressure are the pressures taken at the mid-height of the specimen, it may be necessary to adjust the calibration of the devices to reflect the hydraulic head of fluids in the chamber and back pressure control systems.

5.8 *Pore-Water Pressure-Measurement Device*—The specimen pore-water pressure shall also be measured to the tolerances given in 5.6. During undrained shear, the pore-water pressure shall be measured in such a manner that as little water as possible is allowed to go into or out of the specimen. To achieve this requirement, a very stiff electronic pressure transducer or null-indicating device must be used. With an electronic pressure transducer the pore-water pressure is read directly. With a null-indicating device a pressure control is continuously adjusted to maintain a constant level of the water/mercury interface in the capillary bore of the device. The pressure required to prevent movement of the water is equal to the pore-water pressure. Both measuring devices shall have a compliance of all the assembled parts of the pore-water pressure-measurement system relative to the total volume of the specimen, satisfying the following requirement:

$$(\Delta V/V)/\Delta u < 3.2 \times 10^{-6} \text{ m}^2/\text{kN} \quad (2.2 \times 10^{-5} \text{ in.}^2/\text{lb}) \quad (1)$$

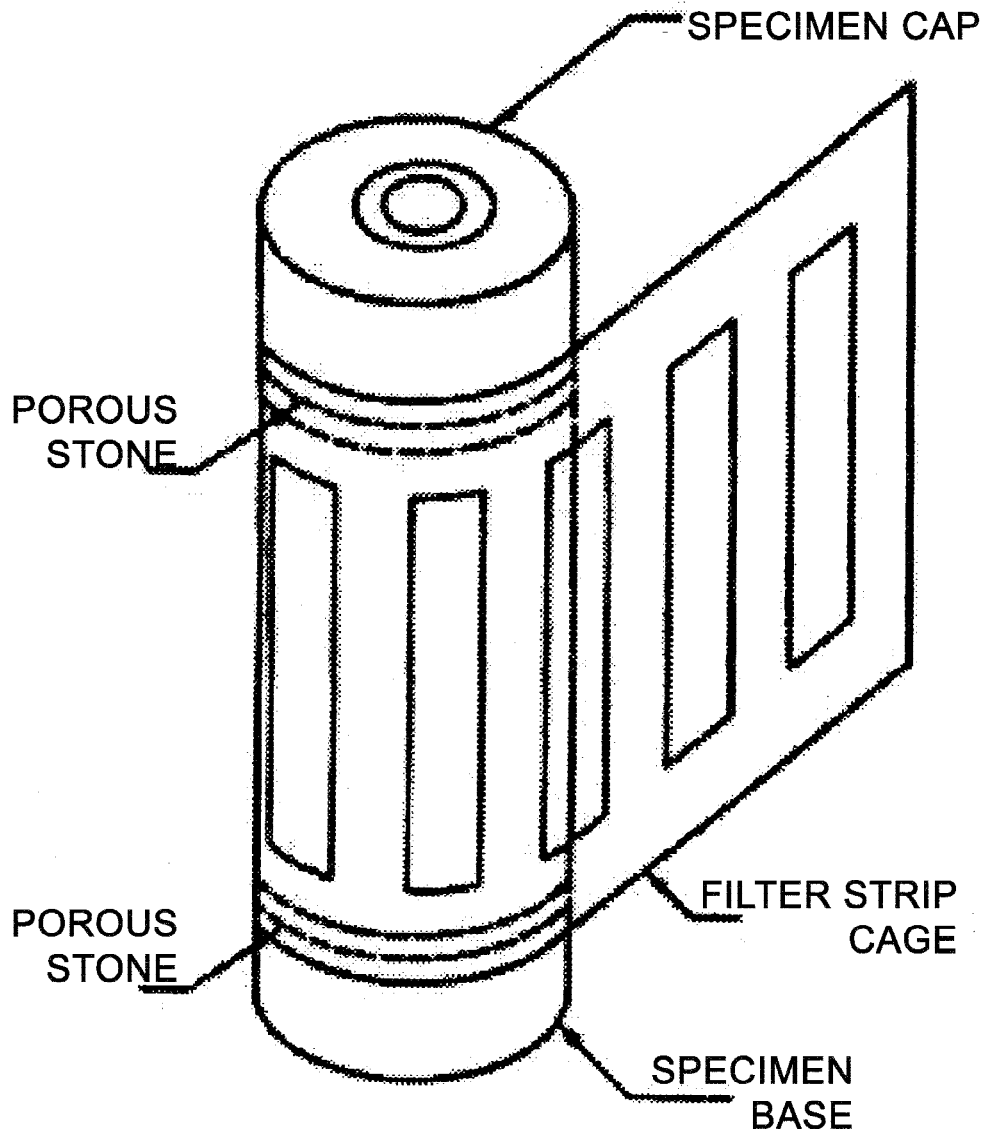

FIG. 2 Filter Strip Cage

where:

ΔV = change in volume of the pore-water measurement system due to a pore pressure change, $\text{mm}^3(\text{in.}^3)$,

V = total volume of the specimen, $\text{mm}^3(\text{in.}^3)$, and

Δu = change in pore pressure, $\text{kPa} (\text{lb}/\text{in.}^2)$.

NOTE 6—To meet the compliance requirement, tubing between the specimen and the measuring device should be short and thick-walled with small bores. Thermoplastic, copper, and stainless steel tubing have been used successfully.

5.9 *Volume Change Measurement Device*—The volume of water entering or leaving the specimen shall be measured with an accuracy of within $\pm 0.05\%$ of the total volume of the specimen. The volume measuring device is usually a burette connected to the back pressure but may be any other device meeting the accuracy requirement. The device must be able to withstand the maximum back pressure.

5.10 *Deformation Indicator*—The vertical deformation of the specimen is usually determined from the travel of the piston acting on the top of the specimen. The piston travel shall be measured with an accuracy of at least 0.25% of the initial specimen height. The deformation indicator shall have a range of at least ~~20%~~ 15% of the initial height of the specimen and may be a dial indicator, linear variable differential transformer (LVDT), extensometer, or other measuring device meeting the requirements for accuracy and range.

5.11 *Specimen Cap and Base*—The specimen cap and base shall be designed to provide drainage from both ends of the specimen. They shall be constructed of a rigid, noncorrosive, impermeable material, and each shall, except for the drainage

provision, have a circular plane surface of contact with the porous disks and a circular cross section. It is desirable for the mass of the specimen cap and top porous disk to be as minimal as possible. However, the mass may be as much as 10 % of the axial load at failure. If the mass is greater than 0.5 % of the applied axial load at failure and greater than 50 g (0.1 lb), the axial load must be corrected for the mass of the specimen cap and top porous disk. The diameter of the cap and base shall be equal to the initial diameter of the specimen. The specimen base shall be connected to the triaxial compression chamber to prevent lateral motion or tilting, and the specimen cap shall be designed such that eccentricity of the piston-to-cap contact relative to the vertical axis of the specimen does not exceed 1.3 mm (0.05 in.). The end of the piston and specimen cap contact area shall be designed so that tilting of the specimen cap during the test is minimal. The cylindrical surface of the specimen base and cap that contacts the membrane to form a seal shall be smooth and free of scratches.

5.12 *Porous Discs*—Two rigid porous disks shall be used to provide drainage at the ends of the specimen. The coefficient of permeability of the disks shall be approximately equal to that of fine sand (1×10^{-4} cm/s (4×10^{-5} in./s)). The disks shall be regularly cleaned by ultrasonic or boiling and brushing and checked to determine whether they have become clogged.

5.13 *Filter-Paper Strips and Disks*—Filter-paper strips are used by many laboratories to decrease the time required for testing. Filter-paper disks of a diameter equal to that of the specimen may be placed between the porous disks and specimen to avoid clogging of the porous disks. If filter strips or disks are used, they shall be of a type that does not dissolve in water. The coefficient of permeability of the filter paper shall not be less than 1×10^{-5} cm/s (4×10^{-6} cm/s) for a normal pressure of 550 kPa (80 lb/in.²). To avoid hoop tension, filter strips should cover no more than 50 % of the specimen periphery. Filter-strip cages have been successfully used by many laboratories. An equation for correcting the principal stress difference (deviator stress) for the effect of the strength of vertical filter strips is given in 10.34.3.1.

NOTE 7—Whatman's No. 54 Filter Paper has been found to meet the permeability and durability requirements.

5.14 *Rubber Membrane*—The rubber membrane used to encase the specimen shall provide reliable protection against leakage. Membranes shall be carefully inspected prior to use and if any flaws or pinholes are evident, the membrane shall be discarded. To offer minimum restraint to the specimen, the unstretched membrane diameter shall be between 90 and 95 % of that of the specimen. The membrane thickness shall not exceed 1 % of the diameter of the specimen. The membrane shall be sealed to the specimen cap and base with rubber O-rings for which the unstressed inside diameter is between 75 and 85 % of the diameter of the cap and base, or by other means that will provide a positive seal. An equation for correcting the principal stress difference (deviator stress) for the effect of the stiffness of the membrane is given in 10.34.3.2.

5.15 *Valves*—Changes in volume due to opening and closing valves may result in inaccurate volume change and pore-water pressure measurements. For this reason, valves in the specimen drainage system shall be of the type that produce minimum volume changes due to their operation. A valve may be assumed to produce minimum volume change if opening or closing the valve in a closed, saturated pore-water pressure system does not induce a pressure change of greater than 0.7 kPa (± 0.1 lb/in.²). All valves must be capable of withstanding applied pressures without leakage.

NOTE 8—Ball valves have been found to provide minimum volume-change characteristics; however, any other type of valve having suitable volume-change characteristics may be used.

5.16 *Specimen-Size Measurement Devices*—Devices used to determine the height and diameter of the specimen shall measure the respective dimensions to within ± 0.1 % of the total dimension and shall be constructed such that their use will not disturb the specimen.

NOTE 9—Circumferential measuring tapes are recommended over calipers for measuring the diameter.

5.17 *Recorders*—Specimen behavior may be recorded manually or by electronic digital or analog recorders. If electronic recorders are used, it shall be necessary to calibrate the measuring devices through the recorder using known input standards.

5.18 *Sample Extruder*—The sample extruder shall be capable of extruding the soil core from the sampling tube at a uniform rate in the same direction of travel as the sample entered the tube and with minimum disturbance of the sample. If the soil core is not extruded vertically, care should be taken to avoid bending stresses on the core due to gravity. Conditions at the time of sample removal may dictate the direction of removal, but the principal concern is to minimize the degree of disturbance.

5.19 *Timer*—A timing device indicating the elapsed testing time to the nearest 1 s shall be used to obtain consolidation data (8.3.3).

5.20 *Balance*—A balance or scale conforming to the requirements of Specification D 4753 readable (with no estimate) to 0.1 % of the test mass or better.

5.21 *Water Deaeration Device*—The amount of dissolved gas (air) in the water used to saturate the specimen shall be decreased by boiling, by heating and spraying into a vacuum, or by any other method that will satisfy the requirement for saturating the specimen within the limits imposed by the available maximum back pressure and time to perform the test.

5.22 *Testing Environment*—The consolidation and shear portion of the test shall be performed in an environment where temperature fluctuations are less than $\pm 4^\circ\text{C}$ ($\pm 7.2^\circ\text{F}$) and there is no direct contact with sunlight.

5.23 *Miscellaneous Apparatus*—Specimen trimming and carving tools including a wire saw, steel straightedge, miter box, vertical trimming lathe, apparatus for preparing compacted specimens, membrane and O-ring expander, water content cans, and data sheets shall be provided as required.

6. Test Specimen Preparation

6.1 *Specimen Size*—Specimens shall be cylindrical and have a minimum diameter of 33 mm (1.3 in.). The average height-to-average diameter ratio shall be between 2 and 2.5. An individual measurement of height or diameter shall not vary from average by more than 5 %. The largest particle size shall be smaller than $\frac{1}{6}$ the specimen diameter. If, after completion of a test, it is found based on visual observation that oversize particles are present, indicate this information in the report of test data (11.42.23).

NOTE 10—If oversize particles are found in the specimen after testing, a particle-size analysis may be performed on the tested specimen in accordance with Test Method D 422 to confirm the visual observation and the results provided with the test report (11.42.4).

6.2 *Undisturbed Specimens*—Prepare undisturbed specimens from large undisturbed samples or from samples secured in accordance with Practice D 1587 or other acceptable undisturbed tube sampling procedures. Samples shall be preserved and transported in accordance with the practices for Group C samples in Practices D 4220. Specimens obtained by tube sampling may be tested without trimming except for cutting the end surfaces plane and perpendicular to the longitudinal axis of the specimen, provided soil characteristics are such that no significant disturbance results from sampling. Handle specimens carefully to minimize disturbance, changes in cross section, or change in water content. If compression or any type of noticeable disturbance would be caused by the extrusion device, split the sample tube lengthwise or cut the tube in suitable sections to facilitate removal of the specimen with minimum disturbance. Prepare trimmed specimens, in an environment such as a controlled high-humidity room where soil water content change is minimized. Where removal of pebbles or crumbling resulting from trimming causes voids on the surface of the specimen, carefully fill the voids with remolded soil obtained from the trimmings. If the sample can be trimmed with minimal disturbance, a vertical trimming lathe may be used to reduce the specimen to the required diameter. After obtaining the required diameter, place the specimen in a miter box, and cut the specimen to the final height with a wire saw or other suitable device. Trim the surfaces with the steel straightedge. Perform one or more water content determinations on material trimmed from the specimen in accordance with Test Method D 2216. Determine the mass and dimensions of the specimen using the devices described in 5.16 and 5.20. A minimum of three height measurements (120° apart) and at least three diameter measurements at the quarter points of the height shall be made to determine the average height and diameter of the specimen.

6.3 *Compacted Specimens*—Soil required for compacted specimens shall be thoroughly mixed with sufficient water to produce the desired water content. If water is added to the soil, store the material in a covered container for at least 16 h prior to compaction. Compacted specimens may be prepared by compacting material in at least six layers using a split mold of circular cross section having dimensions meeting the requirements enumerated in 6.1. Specimens may be compacted to the desired density by either: (1) kneading or tamping each layer until the accumulative mass of the soil placed in the mold is compacted to a known volume; or (2) by adjusting the number of layers, the number of tamps per layer, and the force per tamp. The top of each layer shall be scarified prior to the addition of material for the next layer. The tamper used to compact the material shall have a diameter equal to or less than $\frac{1}{2}$ the diameter of the mold. After a specimen is formed, with the ends perpendicular to the longitudinal axis, remove the mold and determine the mass and dimensions of the specimen using the devices described in 5.16 and 5.20. Perform one or more water content determinations on excess material used to prepare the specimen in accordance with Test Method D 2216.

NOTE 11—It is common for the unit weight of the specimen after removal from the mold to be less than the value based on the volume of the mold. This occurs as a result of the specimen swelling after removal of the lateral confinement due to the mold.

7. Mounting Specimen

7.1 *Preparations*—Before mounting the specimen in the triaxial chamber, make the following preparations:

7.1.1 Inspect the rubber membrane for flaws, pinholes, and leaks.

7.1.2 Place the membrane on the membrane expander or, if it is to be rolled onto the specimen, roll the membrane on the cap or base.

7.1.3 Check that the porous disks and specimen drainage tubes are not obstructed by passing air or water through the appropriate lines.

7.1.4 Attach the pressure-control and volume-measurement system and a pore-pressure measurement device to the chamber base.

7.2 Depending on whether the saturation portion of the test will be initiated with either a wet or dry drainage system, mount the specimen using the appropriate method, as follows in either 7.2.1 or 7.2.2. The dry mounting method is strongly recommended for specimens with initial saturation less than 90 %. The dry mounting method removes air prior to adding backpressure and lowers the backpressure needed to attain an adequate percent saturation.

NOTE 12—It is recommended that the dry mounting method be used for specimens of soils that swell appreciably when in contact with water. If the wet mounting method is used for such soils, it will be necessary to obtain the specimen dimensions after the specimen has been mounted. In such cases, it will be necessary to determine the double thickness of the membrane, the double thickness of the wet filter paper strips (if used), and the combined height of the cap, base, and porous disks (including the thickness of filter disks if they are used) so that the appropriate values may be subtracted from the measurements.

7.2.1 *Wet Mounting Method:*

7.2.1.1 Fill the specimen drainage lines and the pore-water pressure measurement device with deaired water.

7.2.1.2 Saturate the porous disks by boiling them in water for at least 10 min and allow to cool to room temperature.

7.2.1.3 Place a saturated porous disk on the specimen base and after wiping away all free water on the disk, place the specimen on the disk. Next, place another porous disk and the specimen cap on top of the specimen. Check that the specimen cap, specimen, and porous disks are centered on the specimen base.

NOTE 13—If filter-paper disks are to be placed between the porous disks and specimen, they should be dipped in water prior to placement.

7.2.1.4 If filter-paper strips or a filter-paper cage are to be used, saturate the paper with water prior to placing it on the specimen. To avoid hoop tension, do not cover more than 50 % of the specimen periphery with vertical strips of filter paper.

7.2.1.5 Proceed with 7.3.

7.2.2 *Dry Mounting Method:*

7.2.2.1 Dry the specimen drainage system. This may be accomplished by allowing dry air to flow through the system prior to mounting the specimen.

7.2.2.2 Dry the porous disks in an oven and then place the disks in a desiccator to cool to room temperature prior to mounting the specimen.

7.2.2.3 Place a dry porous disk on the specimen base and place the specimen on the disk. Next, place a dry porous disk and the specimen cap on the specimen. Check that the specimen cap, porous disks, and specimen are centered on the specimen base.

NOTE 14—If desired, dry filter-paper disks may be placed between the porous disks and specimen.

7.2.2.4 If filter-paper strips or a filter-paper cage are to be used, the cage or strips may be held in place by small pieces of tape at the top and bottom.

7.3 Place the rubber membrane around the specimen and seal it at the cap and base with two rubber O-rings or other positive seal at each end. A thin coating of silicon grease on the vertical surfaces of the cap and base will aid in sealing the membrane. If filter-paper strips or a filter-paper cage are used, do not apply grease to surfaces in contact with the filter-paper.

7.4 Attach the top drainage line and check the alignment of the specimen and the specimen cap. If the dry mounting method has been used, apply a partial vacuum of approximately 35 kPa (5 lb/in.²) (not to exceed the consolidation stress) to the specimen through the top drainage line prior to checking the alignment. If there is any eccentricity, release the partial vacuum, realign the specimen and cap, and then reapply the partial vacuum. If the wet mounting method has been used, the alignment of the specimen and the specimen cap may be checked and adjusted without the use of a partial vacuum.

8. Procedure

8.1 *Prior to Saturation*—After assembling the triaxial chamber, perform the following operations:

8.1.1 Bring the axial load piston into contact with the specimen cap several times to permit proper seating and alignment of the piston with the cap. During this procedure, take care not to apply an axial load to the specimen exceeding 0.5 % of the estimated axial load at failure. When the piston is brought into contact, record the reading of the deformation indicator to three significant digits.

8.1.2 Fill the chamber with the chamber liquid, being careful to avoid trapping air or leaving an air space in the chamber.

8.2 *Saturation*—The objective of the saturation phase of the test is to fill all voids in the specimen with water without undesirable prestressing of the specimen or allowing the specimen to swell. Saturation is usually accomplished by applying back pressure to the specimen pore water to drive air into solution after saturating the system by either: (1) applying vacuum to the specimen and dry drainage system (lines, porous disks, pore-pressure device, filter-strips or cage, and disks) and then allowing deaired water to flow through the system and specimen while maintaining the vacuum; or (2) saturating the drainage system by boiling the porous disks in water and allowing water to flow through the system prior to mounting the specimen. It should be noted that placing the air into solution is a function of both time and pressure. Accordingly, removing as much air as possible prior to applying back pressure will decrease the amount of air that will have to be placed into solution and will also decrease the back pressure required for saturation. In addition, air remaining in the specimen and drainage system just prior to applying back pressure will go into solution much more readily if deaired water is used for saturation. The use of deaired water will also decrease the time and back pressure required for saturation. Many procedures have been developed to accomplish saturation. The following are suggested procedures:

8.2.1 *Starting with Initially Dry Drainage System*—Increase the partial vacuum acting on top of the specimen to the maximum available vacuum. If the effective consolidation stress under which the strength is to be determined is less than the maximum partial vacuum, apply a lower partial vacuum to the chamber. The difference between the partial vacuum applied to the specimen and the chamber should never exceed the effective consolidation stress for the test and should not be less than 35 kPa (5 lb/in.²) to allow for flow through the sample. After approximately 10 min, allow deaired water to percolate from the bottom to the top of the specimen under a differential vacuum of less than 20 kPa (3 lb/in.²) (Note 15).

8.2.1.1 There should always be a positive effective stress of at least 13 kPa (2 lb/in.²) at the bottom of the specimen during this part of the procedure. When water appears in the burette connected to the top of the specimen, close the valve to the bottom of the specimen and fill the burette with deaired water. Next, reduce the vacuum acting on top of the specimen through the burette to atmospheric pressure while simultaneously increasing the chamber pressure by an equal amount. This process should be performed slowly such that the difference between the pore pressure measured at the bottom of the specimen and the pressure at the top of the specimen should be allowed to equalize. When the pore pressure at the bottom of the specimen stabilizes, proceed with back pressuring of the specimen pore-water as described in 8.2.3. To check for equalization, close the drainage valves to the

specimen and measure the pore pressure change until stable. If the change is less than 5 % of the chamber pressure, the pore pressure may be assumed to be stabilized.

NOTE 15—For saturated clays, percolation may not be necessary and water can be added simultaneously at both top and bottom.

8.2.2 *Starting with Initially Saturated Drainage System*—After filling the burette connected to the top of the specimen with deaired water, apply a chamber pressure of 35 kPa (5 lb/in.²) or less and open the specimen drainage valves. When the pore pressure at the bottom of the specimen stabilizes, according to the method described in 8.2.1, or when the burette reading stabilizes, back pressuring of the specimen pore-water may be initiated.

8.2.3 *Applying Back Pressure*—Simultaneously increase the chamber and back pressure in steps with specimen drainage valves opened so that deaired water from the burette connected to the top and bottom of the specimen may flow into the specimen. To avoid undesirable prestressing of the specimen while applying back pressure, the pressures must be applied incrementally with adequate time between increments to permit equalization of pore-water pressure throughout the specimen. The size of each increment may range from 35 kPa (5 lb/in.²) up to 140 kPa (20 lb/in.²), depending on the magnitude of the desired effective consolidation stress, and the percent saturation of the specimen just prior to the addition of the increment. The difference between the chamber pressure and the back pressure during back pressuring should not exceed 35 kPa unless it is deemed necessary to control swelling of the specimen during the procedure. The difference between the chamber and back pressure must also remain within $\pm 5\%$ when the pressures are raised and within $\pm 2\%$ when the pressures are constant. To check for equalization after application of a back pressure increment or after the full value of back pressure has been applied, close the specimen drainage valves and measure the change in pore-pressure over a 1-min interval. If the change in pore pressure is less than 5 % of the difference between the chamber pressure and the back pressure, another back pressure increment may be added or a measurement may be taken of the pore pressure Parameter *B* (see 8.2.4) to determine if saturation is completed. Specimens shall be considered to be saturated if the value of *B* is equal to or greater than 0.95, or if *B* remains unchanged with addition of back pressure increments.

NOTE 16—Although the pore pressure Parameter *B* is used to determine adequate saturation, the *B*-value is also a function of soil stiffness. If the saturation of the sample is 100 %, the *B*-value measurement will increase with decreasing soil stiffness. Therefore, when testing soft soil samples, a *B*-value of 95 % may indicate a saturation less than 100 %.

NOTE 17—The back pressure required to saturate a compacted specimen may be higher for the wet mounting method than for the dry mounting method and may be as high as 1400 kPa (200 lb/in.²).

NOTE 18—Many laboratories use differential pressure regulators and transducers to achieve the requirements for small differences between chamber and back pressure.

8.2.4 *Measurement of the Pore Pressure Parameter B*—Determine the value of the pore pressure Parameter *B* in accordance with 8.2.4.1 through 8.2.4.4. The pore pressure Parameter *B* is defined by the following equation:

$$B = \Delta u / \Delta \sigma_3 \quad (2)$$

where:

Δu = change in the specimen pore pressure that occurs as a result of a change in the chamber pressure when the specimen drainage valves are closed, and

$\Delta \sigma_3$ = change in the chamber pressure.

8.2.4.1 Close the specimen drainage valves, record the pore pressure, to the nearest 0.7 kPa (0.1 psi), and increase the chamber pressure by 70 kPa (10 lb/in.²).

8.2.4.2 After approximately 2 min, determine and record the maximum value of the induced pore pressure to the nearest 0.7 kPa (0.1 psi). For many specimens, the pore pressure may decrease after the immediate response and then increase slightly with time. If this occurs, values of Δu should be plotted with time and the asymptotic pore pressure used as the change in pore pressure. A large increase in Δu with time or values of Δu greater than $\Delta \sigma_3$ indicate a leak of chamber fluid into the specimen. Decreasing values of Δu with time may indicate a leak in that part of the pore pressure measurement system located outside of the chamber.

8.2.4.3 Calculate the *B*-value using Eq 2.

8.2.4.4 Reapply the same effective consolidation stress as existed prior to the *B*-value by reducing the chamber pressure by 70 kPa (10 lb/in.²) or by alternatively, increasing the back pressure by 70 kPa. If *B* is continuing to increase with increasing back pressure, continue with back pressure saturation. If *B* is equal to or greater than 0.95 or if a plot of *B* versus back pressure indicates no further increase in *B* with increasing back pressure, initiate consolidation.

8.3 *Consolidation*—The objective of the consolidation phase of the test is to allow the specimen to reach equilibrium in a drained state at the effective consolidation stress for which a strength determination is required. During consolidation, data is obtained for use in determining when consolidation is complete and for computing a rate of strain to be used for the shear portion of the test. The consolidation procedure is as follows:

8.3.1 When the saturation phase of the test is completed, bring the axial load piston into contact with the specimen cap, and record the reading on the deformation indicator to three significant digits. During this procedure, take care not to apply an axial load to the specimen exceeding 0.5 % of the estimated axial load at failure. After recording the reading, raise the piston a small distance above the specimen cap, and lock the piston in place.

8.3.2 With the specimen drainage valves closed, hold the maximum back pressure constant and increase the chamber pressure

until the difference between the chamber pressure and the back pressure equals the desired effective consolidation pressure. Consolidation in stages is required when filter strips for radial drainage are used, and the load increment ratio shall not exceed two.

8.3.3 Obtain an initial burette reading, and, then, open appropriate drainage valves so that the specimen may drain from both ends into the burette. At increasing intervals of elapsed time (0.1, 0.2, 0.5, 1, 2, 4, 8, 15, and 30 min and at 1, 2, 4, and 8 h, and so forth) observe and record the burette readings, and, after the 15-min reading, record the accompanying deformation indicator readings obtained by carefully bringing the piston in contact with the specimen cap. If burette and deformation indicator readings are to be plotted against the square root of time, the time intervals at which readings are taken may be adjusted to those that have easily obtained square roots, for example, 0.09, 0.25, 0.49, 1, 4, and 9 min, and so forth. Depending on soil type, time intervals may be changed to convenient time intervals which allow for adequate definition of volume change versus time.

NOTE 19—In cases where significant amounts of fines may be washed from the specimen because of high initial hydraulic gradients, it is permissible to gradually increase the chamber pressure to the total desired pressure over a period with the drainage valves open. If this is done, recording of data should begin immediately after the total pressure is reached.

8.3.4 Plot the burette and deformation indicator readings versus either the logarithm or square root of elapsed time. Allow consolidation to continue for at least one log cycle of time or one overnight period after 100 % primary consolidation has been achieved as determined in accordance with one of the procedures outlined in Test Method D 2435. A marked deviation between the slopes of the burette and deformation indicator curves toward the end of consolidation based on deformation indicator readings indicates leakage of fluid from the chamber into the specimen, and the test ~~should~~ shall be terminated.

8.3.5 Determine the time for 50 % primary consolidation, t_{50} , in accordance with one of the procedures outlined in Test Method D 2435.

8.4 *Shear*—During shear, the chamber pressure shall be kept constant while advancing the axial load piston downward against the specimen cap using controlled axial strain as the loading criterion. Specimen drainage is not permitted during shear.

8.4.1 *Prior to Axial Loading*—Before initiating shear, perform the following:

8.4.1.1 By opening or closing the appropriate valves, isolate the specimen so that during shear the specimen pore-water pressure will be measured by the pore-pressure measurement device and no drainage will occur.

8.4.1.2 Place the chamber in position in the axial loading device. Be careful to align the axial loading device, the axial load-measuring device, and the triaxial chamber to prevent the application of a lateral force to the piston during shear.

8.4.1.3 Bring the axial load piston into contact with the specimen cap to permit proper seating and realignment of the piston with the cap. During this procedure, care should be taken not to apply an axial load to the specimen exceeding 0.5 % of the estimated axial load at failure. If the axial load-measuring device is located outside of the triaxial chamber, the chamber pressure will produce an upward force on the piston that will react against the axial loading device. In this case, start shear with the piston slightly above the specimen cap, and before the piston comes into contact with the specimen cap, either (1) measure and record the initial piston friction and upward thrust of the piston produced by the chamber pressure and later correct the measured axial load, or (2) adjust the axial load-measuring device to compensate for the friction and thrust. The variation in the axial load-measuring device reading should not exceed 0.1 % of the estimated failure load when the piston is moving downward prior to contacting the specimen cap. If the axial load-measuring device is located inside the chamber, it will not be necessary to correct or compensate for the uplift force acting on the axial loading device or for piston friction. However, if an internal load-measuring device of significant flexibility is used in combination with an external deformation indicator, correction of the deformation readings may be necessary. In both cases, record the initial reading on the pore-water pressure measurement device to the nearest 0.7 kPa (0.1 psi) immediately prior to when the piston contacts the specimen cap and the reading on the deformation indicator to three significant digits when the piston contacts the specimen cap.

8.4.1.4 Check for pore pressure stabilization. Record the pore pressure to the nearest 0.7 kPa (0.1 psi). Close the drainage valves to the specimen, and measure the pore pressure change until stable. If the change is less than 5 % of the chamber pressure, the pore pressure may be assumed to be stabilized.

8.4.2 *Axial Loading*—Apply axial load to the specimen using a rate of axial strain that will produce approximate equalization of pore pressures throughout the specimen at failure. Assuming failure will occur after 4 %, a suitable rate of strain, $\dot{\epsilon}$, may be determined from the following equation:

$$\dot{\epsilon} = 4 \% / (10 t_{50}) \quad (3)$$

where:

t_{50} = time value obtained in 8.3.5.

If, however, it is estimated that failure will occur at a strain value lower than 4 %, a suitable strain rate may be determined using Eq 3 by replacing 4 % with the estimated failure strain. This rate of strain will provide for determination of accurate effective stress paths in the range necessary to define effective strength envelopes.

8.4.2.1 At a minimum, record ~~load, deformation, load and deformation~~ load and deformation to three significant digits, and pore-water pressure values to the nearest 0.7 kPa (0.1 psi), at increments of 0.1 to 1 % strain and, thereafter, at every 1 %. Take sufficient readings to define the stress-strain curve; hence, more frequent readings may be required in the early stages of the test and as failure is approached. Continue the loading to 15 % strain, except loading may be stopped when the principal stress difference (deviator stress) has dropped 20 % or when 5 % additional axial strain occurs after a peak in principal stress difference (deviator stress).

NOTE 20—The use of a manually adjusted null-indicating device will require nearly continuous attention to ensure the criterion for undrained shear.

9. Removing Specimen

9.1 When shear is completed, perform the following:

9.1.1 Remove the axial load and reduce the chamber and back pressures to zero.

9.1.2 With the specimen drainage valves remaining closed, quickly remove the specimen from the apparatus so that the specimen will not have time to absorb water from the porous disks.

9.1.3 Remove the rubber membrane (and the filter-paper strips or cage from the specimen if they were used), and determine the water content of the total specimen in accordance with the procedure in Test Method D 2216. (Free water remaining on the specimen after removal of the membrane should be blotted away before obtaining the water content.) In cases where there is insufficient material from trimmings for index property tests, that is, where specimens have the same diameter as the sampling tube, the specimen should be weighed prior to removing material for index property tests and a representative portion of the specimen used to determine its final water content. Prior to placing the specimen (or portion thereof) in the oven to dry, sketch or photograph the specimen showing the mode of failure (shear plane, bulging, and so forth).

10. Calculation

10.1 Measurements and calculations shall contain three significant digits.

10.2 Initial Specimen Properties—Using the dry mass of the total specimen, calculate and record the initial water content, volume of solids, initial void ratio, initial percent saturation, and initial dry unit weight. Calculate the specimen volume from values measured in 6.2 or 6.3. Calculate the volume of solids by dividing the dry mass of the specimen by the specific gravity of the solids (Note 20) and dividing by the density of water. Calculate the void ratio by dividing the volume of voids by the volume of solids where the volume of voids is assumed to be the difference between the specimen volume and the volume of the solids. Calculate dry density by dividing the dry mass of the specimen by the specimen volume.

NOTE 21—The specific gravity of solids can be determined in accordance with Test Method D 854 or it may be assumed based on previous test results.

10.23 Specimen Properties After Consolidation—Calculate the specimen height and area after consolidation as follows:

10.23.1 Height of specimen after consolidation, H_{oc} , is determined from the following equation:

$$H_o = H_o - \Delta H_o \quad (4)$$

$$H_c = H_o - \Delta H_o \quad (4)$$

where:

H_o = initial height of specimen, and

ΔH_o = change in height of specimen at end of consolidation.

See Fig. 3.

10.23.2 The cross-sectional area of the specimen after consolidation, A_c , shall be computed using one of the following methods. The choice of the method to be used depends on whether shear data are to be computed as the test is performed (in which case Method A would be used) or on which of the two methods, in the opinion of a qualified person, yield specimen conditions considered to be most representative of those after consolidation. Alternatively, the average of the two calculated areas may be appropriate.

10.23.2.1 Method A:

$$A_c = (V_o - \Delta V_{sat} - \Delta V_c) / H_c \quad (5)$$

where:

V_o = initial volume of specimen,

ΔV_c = change in volume of specimen during consolidation as indicated by burette readings, and

ΔV_{sat} = change in volume of specimen during saturation as follows:

$$\Delta V_{sat} = 3V_o[\Delta H_s / H_o]$$

where:

ΔH_s = change in height of the specimen during saturation.

10.23.2.2 Method B:

$$A_c = (V_{wf} + V_s) / H_c \quad (6)$$

where:

V_{wf} = final volume of water (based on final water content), and

V_s = volume of solids as follows:

$$V_s = w_s / (G_s \rho_w)$$

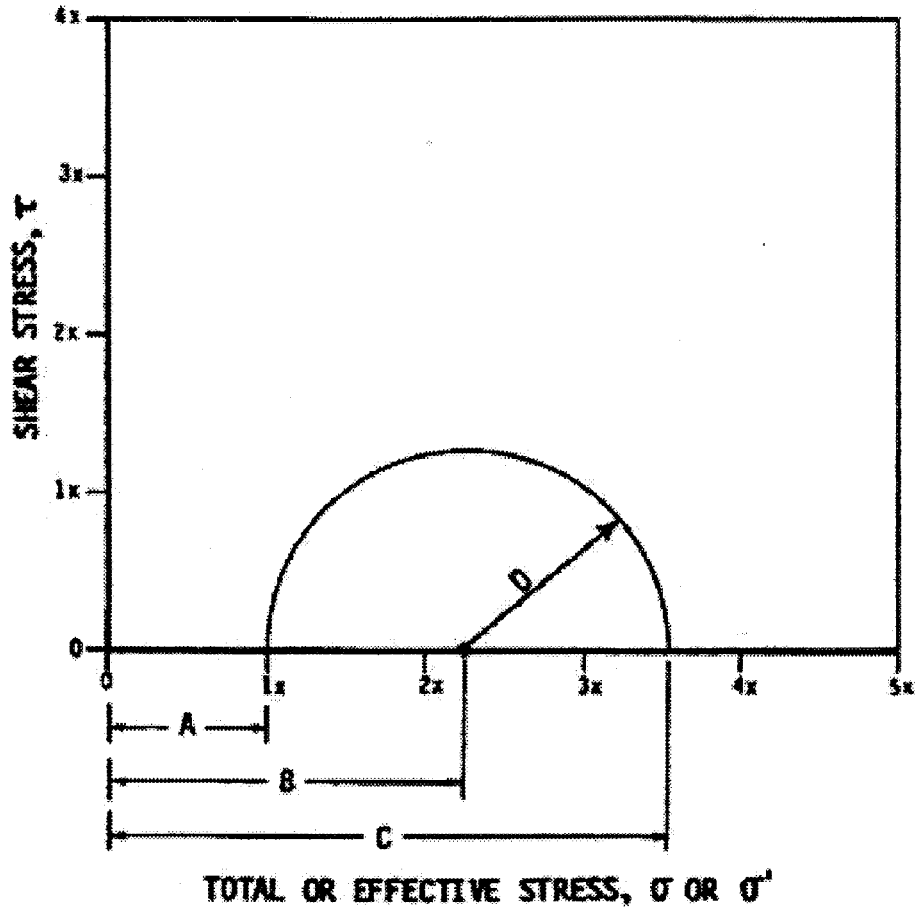

- A = TOTAL OR EFFECTIVE MINOR PRINCIPAL STRESS (σ_3 or σ_3')
- B = AVERAGE OF TOTAL OR EFFECTIVE PRINCIPAL STRESSES
- C = TOTAL OR EFFECTIVE MAJOR PRINCIPAL STRESS (σ_1 or σ_1')
- D = RADIUS OF THE MOHR'S CIRCLE; HALF THE PRINCIPAL STRESS DIFFERENCE

FIG. 3 Construction of Mohr Stress Circle

where:

- w_s = specimen dry mass,
- G_s = specific gravity of solids, and
- p_w = density of water.

10.23.3 Using the calculated dimensions of the specimen after consolidation, and assuming that the water content after consolidation is the same as the final water content, calculate the consolidated void ratio and percent saturation.

NOTE 22—The specimen will absorb water from the porous disks and drainage lines during the time it is being removed from the apparatus. When this effect is significant, Method A will yield more reasonable values.

NOTE 23— In this test method, the equations are written such that compression and consolidation are considered positive.

10.34 Shear Data:

10.34.1 Calculate the axial strain, ϵ_1 , for a given applied axial load as follows:

$$\epsilon_1 = \Delta H / H_c \tag{7}$$

where:

ΔH = change in height of specimen during loading as determined from deformation indicator readings, and

H_c = height of specimen after consolidation.

10.34.2 Calculate the cross-sectional area, A , for a given applied axial load as follows:

$$A = A_c / (1 - \epsilon_1) \quad (8)$$

where:

A_c = average cross-sectional area of the specimen after consolidation, and

ϵ_1 = axial strain for the given axial load.

NOTE 24—The cross-sectional area computed in this manner is based on the assumption that the specimen deforms as a right circular cylinder during shear. In cases where there is localized bulging, it may be possible to determine more accurate values for the area based on specimen dimension measurements obtained after shear.

10.34.3 Calculate the principal stress difference (deviator stress), $\sigma_1 - \sigma_3$, for a given applied axial load as follows:

$$\sigma_1 - \sigma_3 = P / A \quad (9)$$

where:

P = given applied axial load (corrected for uplift and piston friction if required as obtained in 8.4.1.3), and

A = corresponding cross-sectional area.

10.34.3.1 *Correction for Filter-Paper Strips*— For vertical filter-paper strips which extend over the total length of the specimen, apply a filter-paper strip correction to the computed values of the principal stress difference (deviator stress), if the error in principal stress difference (deviator stress) due to the strength of the filter-paper strips exceeds 5 %.

(1) For values of axial strain above 2 %, use the following equation to compute the correction:

$$\Delta(\sigma_1 - \sigma_3) = K_{fp} P_{fp} / A_c \quad (10)$$

where:

$\Delta(\sigma_1 - \sigma_3)$ = correction to be subtracted from the measured principal stress difference (deviator stress),

K_{fp} = load carried by filter-paper strips per unit length of perimeter covered by filter-paper,

P_{fp} = perimeter covered by filter-paper, and

A_c = cross-sectional area of specimen after consolidation.

(2) For values of axial strain of 2 % or less, use the following equation to compute the correction:

$$\Delta(\sigma_1 - \sigma_3) = 50\epsilon_1 K_{fp} P_{fp} / A_c \quad (11)$$

where:

ϵ_1 = axial strain (decimal form) and other terms are the same as those defined in Subparagraph (1) of 10.34.3.1.

NOTE 25—For filter-paper generally used in triaxial testing, K_{fp} is approximately 0.19 kN/m (1.1 lb/in.).

10.34.3.2 *Correction for Rubber Membrane*— Use the following equation to correct the principal stress difference (deviator stress) for the effect of the rubber membrane if the error in principal stress difference (deviator stress) due to the strength of the membrane exceeds 5 %:

$$\Delta(\sigma_1 - \sigma_3) = (4E_m t_m \epsilon) / D_c \quad (12)$$

where:

$\Delta(\sigma_1 - \sigma_3)$ = correction to be subtracted from the measured principal stress difference (deviator stress),

D_c = $\sqrt{4A_c/\pi}$ = diameter of specimen after consolidation,

E_m = Young's modulus for the membrane material,

t_m = thickness of the membrane, and

ϵ_1 = axial strain (decimal form).

(1) The Young's modulus of the membrane material may be determined by hanging a 15-mm (0.5-in.) circumferential strip of membrane using a thin rod, placing another rod through the bottom of the hanging membrane, and measuring the force per unit strain obtained by stretching the membrane. The modulus value may be computed using the following equation:

$$E_m = (F / A_m) / (\Delta L / L) \quad (13)$$

where:

E_m = Young's modulus of the membrane material,

F = force applied to stretch the membrane,

L = unstretched length of the membrane,

ΔL = change in length of the membrane due to the force, F , and

A_m = area of the membrane = $2 t_m W_s$

where:

t_m = thickness of the membrane, and

W_s = width of circumferential strip, 0.5 in. (15 mm).

NOTE 26—A typical value of E_m for latex membranes is 1400 kPa (200 lb/in.).

NOTE 27—The corrections for filter-paper strips and membranes are based on simplified assumptions concerning their behavior during shear. Their actual behavior is complex, and there is not a consensus on more exact corrections.

10.34.4 Calculate the effective minor principal stress, σ'_3 for a given applied axial load as follows:

$$\sigma'_3 = \sigma_3 - \Delta u \quad (14)$$

where:

σ_3 = effective consolidation stress, and

Δu = induced pore-water pressure at the given axial load (total pore-water pressure minus the total back pressure).

10.45 *Principal Stress Difference (Deviator Stress) and Induced Pore-Water Pressure versus Strain Curves*—Prepare graphs showing relationships between principal stress difference (deviator stress) and induced pore-water pressure with axial strain, plotting deviator stress and induced pore-water pressure as ordinates and axial strain as abscissa. Select the principal stress difference (deviator stress) and axial strain at failure in accordance with 3.2.3.

10.56 *$p' - q$ Diagram*—Prepare a graph showing the relationship between p' , $(\sigma'_1 + \sigma'_3)/2$ and q , $(\sigma_1 - \sigma_3)/2$, plotting q as ordinate and p' as abscissa using the same scale. The value of p' for a given axial load may be computed as follows:

$$p' = ((\sigma_1 - \sigma_3) + 2\sigma'_3) / 2 \quad (15)$$

where:

$\sigma_1 - \sigma_3$ = principal stress difference (deviator stress), and

σ'_3 = effective minor principal stress.

10.67 Determine the major and minor principal stresses at failure based on total stresses, σ_{1f} and σ_{3f} respectively, and on effective stresses, σ'_{1f} and σ'_{3f} respectively, as follows:

$$\sigma_{3f} = \text{effective consolidation stress,} \quad (16)$$

$$\sigma_{1f} = (\sigma_1 - \sigma_3) \text{ at failure} + \sigma_{3f} \quad (17)$$

$$\sigma'_{3f} = \sigma_{3f} - \Delta u_f, \text{ and} \quad (18)$$

$$\sigma'_{1f} = (\sigma_1 - \sigma_3) \text{ at failure} + \sigma'_{3f} \quad (19)$$

where Δu_f is the induced pore-water pressure at failure.

10.78 *Mohr Stress Circles*—If desired, construct Mohr stress circles at failure based on total and effective stresses on an arithmetic plot with shear stress as ordinate and normal stress as abscissa using the same scales. The circle based on total stresses is drawn with a radius of one half the principal stress difference (deviator stress) at failure with its center at a value equal to one half the sum of the major and minor total principal stresses. The Mohr stress circle based on effective stresses is drawn in a similar manner except that its center is at a value equal to one half the sum of the major and minor effective principal stresses.

11. Report: Test Data Sheet(s)/Form(s)

11.1 The methodology used to specify how data are recorded on the data sheet(s)/form(s), as given below, is covered in 1.5.

11.2 Record as a minimum the following general information (data):

11.2.1 Identification data and visual description of specimen, including soil classification and whether the specimen is undisturbed, compacted, or otherwise prepared,

11.2.2 Values of plastic limit and liquid limit, if determined in accordance with Test Method D 4318,

11.2.3 Value of specific gravity of solids and notation if the value was determined in accordance with Test Method D 854 or assumed,

11.2.4 Particle-size analysis, if determined in accordance with Test Method D 422,

11.2.5 Initial specimen dry unit weight, void ratio, water content, and percent saturation, (specify if the water content specimen was obtained from cuttings or the entire specimen),

NOTE 28—The specific gravity determined in accordance with Test Method D 854 is required for calculation of the saturation. An assumed specific gravity may be used provided it is noted in the test report that an assumed value was used.

11.2.6 Initial height and diameter of specimen,

11.2.7 Method followed for specimen saturation (that is, dry or wet method),

11.2.8 Total back pressure,

11.2.9 The pore pressure Parameter B at the end of saturation,

11.2.10 Effective consolidation stress,

11.2.11 Time to 50 % primary consolidation,

11.2.12 Specimen dry unit weight, void ratio, water content, and percent saturation after consolidation,

11.2.13 Specimen cross-sectional area after consolidation and method used for determination,

11.2.14 Failure criterion used,

11.2.15 The value of the principal stress difference (deviator stress) at failure and the values of the effective minor and major principal stresses at failure, (indicate when values have been corrected for effects due to membrane or filter strips, or both),

- 11.42.16 Axial strain at failure, percent,
- 11.42.17 Rate of strain, percent per minute,
- 11.42.18 Principal stress difference (deviator stress) and induced pore-water pressure versus axial strain curves as described in 10.45,
- 11.42.19 The $p' - q$ diagram as described in 10.56,
- 11.42.20 Mohr stress circles based on total and effective stresses, (optional),
- 11.42.21 Slope of angle of the failure surface (optional),
- 11.42.22 Failure sketch or photograph of the specimen, and
- 11.42.23 Remarks and notations regarding any unusual conditions such as slickensides, stratification, shells, pebbles, roots, and so forth, or other information necessary to properly interpret the results obtained, including any departures from the procedure outlined.

12. Precision and Bias

12.1 *Precision*—~~Data are being evaluated—Test data on precision is not presented due to determine the precision nature of the soil materials tested by this test method. In addition, procedure. It is either not feasible or too costly at this time to have ten or more laboratories participate in a round-robin testing program. Subcommittee D18.05 is seeking pertinent~~ is seeking any data from users of this test method that might be used to make a limited statement on precision.

12.2 *Bias*—There is no accepted reference value for this test method, therefore, bias cannot be determined.

13. Keywords

13.1 back pressure saturation; cohesive soil; consolidated undrained strength; strain-controlled loading; stress-strain relationships; total and effective stresses

SUMMARY OF CHANGES

Many parts

In accordance with Committee D18 policy, this section identifies the location of changes to this test method have been changed so standard since the last edition (1995) that may impact the use of this test method contains wording similar standard.

- (1) New sections 1.5 and 1.5.1 were added to Test Methods D 2850 address significant digits.
- (2) Several sections were changed to comply iwth D18 SPM policy requirements: 1.6, 12.1, and D 2166. Some parts Summary of this test method have been modified Changes.
- (3) Practice D 6026 was added to further clarify this test method. Specifically, additional guidanee has been provided Referenced Documents section.
- (4) Permissive language was eliminated in the mounting method sections. The sections on the B-factor have been expanded. Other general improvements have been made. Some 5.2, 5.6, and 8.3.4.
- (5) Requirements for measurements using significant digits were added in sections 8.1.1, 8.2.4.1, 8.2.4.2, 8.3.1, 8.4.1.3, 8.4.1.4, 8.4.2.1, 10.1, and 11.1.
- (6) Section 11 was reformatted.
- (7) Sections 10 and 11 were renumbered due to addition of subsections.
- (8) Equation 4 was corrected.
- (9) Figures 1, 2, and 3 were added. These figures were omitted from the previous version.
- (10) Requirements for accuracy have been changed to be more consistent with the desired accuracy of this test method. deformation indicator was changed in section 5.10.

ASTM International takes no position respecting the validity of any patent rights asserted in connection with any item mentioned in this standard. Users of this standard are expressly advised that determination of the validity of any such patent rights, and the risk of infringement of such rights, are entirely their own responsibility.

This standard is subject to revision at any time by the responsible technical committee and must be reviewed every five years and if not revised, either reapproved or withdrawn. Your comments are invited either for revision of this standard or for additional standards and should be addressed to ASTM International Headquarters. Your comments will receive careful consideration at a meeting of the responsible technical committee, which you may attend. If you feel that your comments have not received a fair hearing you should make your views known to the ASTM Committee on Standards, at the address shown below.

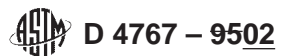

This standard is copyrighted by ASTM International, 100 Barr Harbor Drive, PO Box C700, West Conshohocken, PA 19428-2959, United States. Individual reprints (single or multiple copies) of this standard may be obtained by contacting ASTM at the above address or at 610-832-9585 (phone), 610-832-9555 (fax), or service@astm.org (e-mail); or through the ASTM website (www.astm.org).