



# Standard Test Method for Field Measurement of Infiltration Rate Using a Double-Ring Infiltrometer with a Sealed-Inner Ring<sup>1</sup>

This standard is issued under the fixed designation D 5093; the number immediately following the designation indicates the year of original adoption or, in the case of revision, the year of last revision. A number in parentheses indicates the year of last reapproval. A superscript epsilon ( $\epsilon$ ) indicates an editorial change since the last revision or reapproval.

## 1. Scope \*

1.1 This test method describes a procedure for measuring the infiltration rate of water through in-place soils using a double-ring infiltrometer with a sealed inner ring.

1.2 This test method is useful for soils with infiltration rates in the range of  $1 \times 10^{-7}$  m/s to  $1 \times 10^{-10}$  m/s. When infiltration rates  $\geq 1 \times 10^{-7}$  m/s are to be measured Test Method D 3385 shall be used.

1.3 All observed and calculated values shall conform to the guide for significant digits and rounding established in Practice D 6026.

1.3.1 The method used to specify how data are collected, calculated, or recorded in this standard is not directly related to the accuracy to which the data can be applied in design or other uses, or both. How one applies the results obtained using this standard is beyond its scope.

1.4 This test method provides a direct measurement of infiltration rate, not hydraulic conductivity. Although the units of infiltration rate and hydraulic conductivity are similar, there is a distinct difference between these two quantities. They cannot be directly related unless the hydraulic boundary conditions, such as hydraulic gradient and the extent of lateral flow of water are known or can be reliably estimated.

1.5 This test method can be used for natural soil deposits, recompacted soil layers, and amended soils such as soil bentonite and soil lime mixtures.

1.6 The values stated in SI units are to be regarded as standard. The values in parentheses are for information only.

1.7 *This standard does not purport to address all of the safety concerns, if any, associated with its use. It is the responsibility of the user of this standard to establish appropriate safety and health practices and determine the applicability of regulatory limitations prior to use.*

## 2. Referenced Documents

### 2.1 ASTM Standards:

D 653 Terminology Relating to Soil, Rock, and Contained Fluids<sup>2</sup>

D 3385 Test Method for Infiltration Rate of Soils in Field Using Double Ring Infiltrometers<sup>2</sup>

D 3740 Practice for Minimum Requirements for Agencies Engaged in the Testing and/or Inspection of Soil and Rock Used in Engineering Design and Construction<sup>2</sup>

D 6026 Practice for Using Significant Digits in Geotechnical Data<sup>3</sup>

## 3. Terminology

### 3.1 Definitions:

3.1.1 *infiltration*—downward entry of liquid into a porous body.

3.1.2 *infiltration rate, I*—quantity of liquid entering a porous material ( $m^3$ ) per unit area ( $m^2$ ) per unit time (s), expressed in units of m/s.

3.1.3 *infiltrometer*—a device used to pond liquid on a porous body and to allow for the measurement of the rate at which liquid enters the porous body.

3.1.4 For definitions of other terms used in this test method, see Terminology D 653.

## 4. Summary of Test Method

4.1 The infiltration rate of water through soil is measured using a double-ring infiltrometer with a sealed or covered inner ring (Fig. 1). The infiltrometer consists of an open outer and a sealed inner ring. The rings are embedded and sealed in trenches excavated in the soil. Both rings are filled with water such that the inner ring is submerged.

4.2 The rate of flow is measured by connecting a flexible bag filled with a known weight of water to a port on the inner ring. As water infiltrates into the ground from the inner ring, an equal amount of water flows into the inner ring from the flexible bag. After a known interval of time, the flexible bag is removed and weighed. The weight loss, converted to a volume, is equal to the amount of water that has infiltrated into the ground. An infiltration rate is then determined from this volume of water, the area of the inner ring, and the interval of

<sup>1</sup> This test method is under the jurisdiction of ASTM Committee D18 on Soil and Rock and is the direct responsibility of Subcommittee D18.04 on Hydrologic Properties of Soil and Rocks.

Current edition approved July 10, 2002. Published September 2002. Originally published as D5093-90. Last previous edition D5093-90(1997).

<sup>2</sup> *Annual Book of ASTM Standards*, Vol 04.08.

<sup>3</sup> *Annual Book of ASTM Standards*, Vol 04.09.

\*A Summary of Changes section appears at the end of this standard.

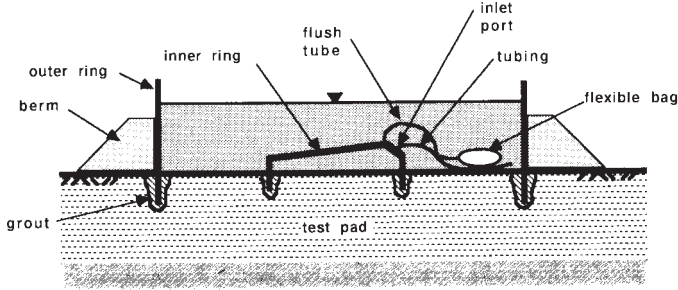

FIG. 1 Schematic Of A Double-Ring Infiltrometer With A Sealed Inner Ring

time. This process is repeated and a plot of infiltration rate versus time is constructed. The test is continued until the infiltration rate becomes steady or until it becomes equal to or less than a specified value.

### 5. Significance and Use

5.1 This test method provides a means to measure low infiltration rates associated with fine-grained, clayey soils, and are in the range of  $1 \times 10^{-7}$  m/s to  $1 \times 10^{-9}$  m/s.

5.2 This test method is particularly useful for measuring liquid flow through soil moisture barriers such as compacted clay liner or covers used at waste disposal facilities, for canal and reservoir liners, for seepage blankets, and for amended soil liners such as those used for retention ponds or storage tanks.

5.3 The purpose of the sealed inner ring is to: (1) provide a means to measure the actual amount of flow rather than a drop in water elevation which is the flow measurement procedure used in Test Method D 3385 and (2) to eliminate evaporation losses.

5.4 The purpose of the outer ring is to promote one-dimensional, vertical flow beneath the inner ring. The use of large diameter rings and large depths of embedments helps to ensure that flow is essentially one-dimensional.

5.5 This test method provides a means to measure infiltration rate over a relatively large area of soil. Tests on large volumes of soil can be more representative than tests on small volumes of soil.

5.6 The data obtained from this test method are most useful when the soil layer being tested has a uniform distribution of pore space, and when the density and degree of saturation and the hydraulic conductivity of the material underlying the soil layer are known.

5.7 Changes in water temperature can introduce significant error in the volume change measurements. Temperature changes will cause water to flow in or out of the inner ring due to expansion or contraction of the inner ring and the water contained within the inner ring.

5.8 The problem of temperature changes can be minimized by insulating the rings, by allowing enough flow to occur so that the amount of flow resulting from a temperature change is not significant compared to that due to infiltration, or by connecting and disconnecting the bag from the inner ring when the water in the inner ring is at the same temperature.

5.9 If the soil being tested will later be subjected to increased overburden stress, then the infiltration rate can be expected to decrease as the overburden stress increases. Labo-

ratory hydraulic conductivity tests are recommended for studies of the influence of level of stress on the hydraulic properties of the soil.

NOTE 1—The quality of the result produced by this standard depends on the competence of the personnel performing it and the suitability of the equipment and facilities being used. Agencies that meet the criteria of Practice D 3740 are generally considered capable of competent and objective testing, sampling, inspection, etc. Users of this standard are cautioned that compliance with Practice D 3740 does not in itself ensure reliable results. Reliable results depend on many factors; Practice D 3740 provides a means of evaluating some of those factors

### 6. Apparatus

6.1 *Infiltrometer Rings*—The rings shall be constructed of a stiff, corrosion-resistant material such as metal, plastic, or fiberglass. The shape of the rings can be circular or square. However, square rings are recommended because it is easier to excavate straight trenches in the soil. The rings can be of any size provided: (1) the minimum width or diameter of the inner ring is 610 mm (24 in.); and (2) a minimum distance of 610 mm is maintained between the inner and outer ring. The following is a description of a set of rings that can be constructed from commonly available materials, incorporates the requirements described above, and has worked well in the field.

6.1.1 *Outer Ring*—A square ring (Fig. 2) comprised of four sheets of aluminum approximately 3.6 m by 910 mm by 2 mm (12 ft by 36 in. by 0.080 in.) The top edge of the aluminum sheet is bent 90° in order to provide rigidity. A hole is provided in the center of the top edge. One edge of each sheet is bent 90°. Holes are drilled along each side edge so that the sheets can be bolted at the corners. A flat rubber gasket provides a seal at each corner. A wire cable approximately 15 m long with a clamp may be needed to tie the top edges together.

6.1.2 *Inner Ring*—A square ring (Fig. 3), 1.52 m (5 ft) on a side, made of fiberglass provided with two ports. The top is shaped in such a way as to vent air from the ring as it is filled. A port is provided at the highest point so that any air that accumulates in the ring during the test can be flushed out. One port must be located at the top of the ring. The other port must be located beneath the top port. A 150 mm (6 in.) skirt, that is embedded into the soil, is provided along the edge of the ring. Barbed fittings that accept flexible tubing are attached to the ports. Handles are provided at each corner of the inner ring.

6.2 *Flexible Bag*—Two clear flexible bags with a capacity of 1000 to 3000 mL. Intravenous bags available from medical

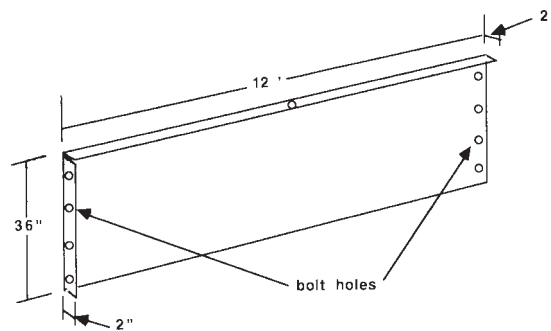
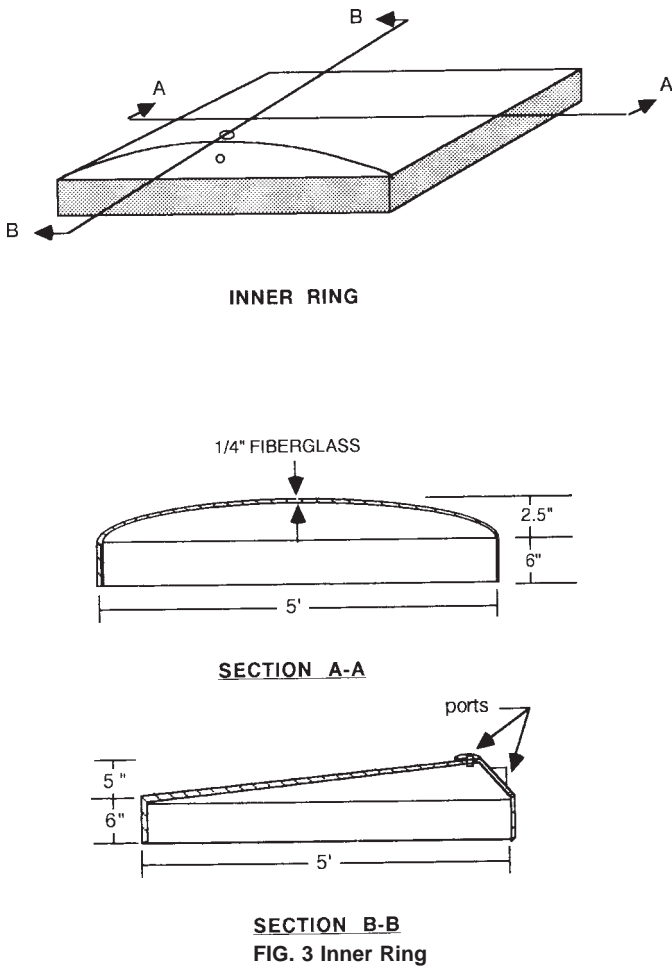

FIG. 2 Panel For Outer Ring



supply stores work well. A means for attaching a shut-off valve to the bag shall be provided. The shut-off valve shall be provided with a barbed fitting that will connect to the inlet tube on the inner ring.

6.3 *Tubing*—Clear, flexible tubing approximately 4.5 m (15 ft) long with a minimum ID of 6 mm (1/4 in.)

6.4 *Scissors or Knife.*

6.5 *Excavation Tools.*

6.5.1 *Mason's Hammer*—Hammer with a blade approximately 120 mm long and 40 mm wide.

6.5.2 *Trenching Machine*—Capable of excavating a trench with a maximum width of 150 mm (6 in.) and a depth of 460 mm (18 in.)

6.5.3 *Chain Saw*—(Optional—see Note 2) Equipped with a carbide-tipped chain and bar.

6.5.4 *Hand Shovel*, garden type.

6.6 *Levels*—A surveyor's level and rod and a carpenter's level.

6.7 *Buckets*—Five buckets with a capacity of approximately 20 L (5 gal.)

6.8 *Blocks*—Cinder blocks to serve as a platform for the flexible bag.

6.9 *Cover*—An opaque cover to place on top of the outer ring. The cover can be a tarp or plywood supported by wooden beams.

6.10 *Grout*—A bentonite grout for filling the trenches and sealing the rings in place.

6.11 *Mixing Equipment*—A large (four bag) grout mixer for mixing the bentonite grout.

6.12 *Trowel.*

6.13 *Thermometer*—Readable to 0.5°C with a range of 0 to 50°C.

6.14 *Scale*—Capacity of 4000 g and an accuracy of 1 g.

6.15 *Watch*—Readable to 1 s.

6.16 *Water Supply*—Preferably water of the same quality as that involved in the problem being examined. Approximately 5600 L (1400 gal) are needed for this test.

6.17 *Splash Guard*—Plywood, rubber sheet, or burlap 600 by 600 mm (2 by 2 ft).

## 7. Test Site

7.1 The test requires an area of approximately 7.3 by 7.3 m (24 by 24 ft).

7.2 The slope to the test area should be no greater than approximately 3 %.

7.3 The test may be set up in a pit if infiltration rates are desired at depth rather than at the surface.

7.4 The test area shall be covered with a sheet of plastic to keep the surface from drying.

7.5 Representative samples of the soil to be tested shall be taken before and after the test to determine its moisture content, density, and specific gravity. The thickness of the layer being tested shall be determined as well as the approximate hydraulic conductivity of the layer beneath it.

## 8. Procedure

8.1 *Assembly of Outer Ring*—Wipe off gaskets and side edges of the outer ring. Align gasket between the edges and bolt edges together.

8.2 *Excavation of Trenches:*

8.2.1 Place both rings on the area to be tested. Center the inner ring within the outer ring. Make sure that the outer ring is square by using the tape measure to check that the length of the diagonals are equal.

8.2.2 If plastic is covering the test area, cut out thin strips along the edge of each ring so that the trenches can be excavated. Leave as much of the plastic on as possible in order to keep the soil from drying.

8.2.3 Use the bottom edge of each ring to scribe a line on the ground to use as a guide for excavating the trenches.

8.2.4 Note the orientation of the rings and set them aside.

8.2.5 Use the surveyor's level and check the ground elevation where the corners of each ring will be. Note the high spots and excavate deeper in these areas so that the rings will be level.

8.2.6 Use the trenching machine and excavate a trench for the outer ring. The trench should be about 146 mm (18 in.) deep. Excavate deeper at high spots.

8.2.7 Use a small hand shovel to remove any loose material in the trenches.

8.2.8 Place the outer ring in the trench and use the carpenter's level to check that the top of the ring is reasonably level ( $\pm 30$  mm). Also check that the outer ring is square. Remove the ring and excavate any areas keeping the ring from being level and square.

8.2.9 Set the outer ring aside and cover the trenches to prevent the soil from drying.

8.2.10 Use the mason's hammer and excavate a trench 50 by 110 mm (2 by 4.5 in.) for the inner ring. Excavate deeper in high spots so that the inner ring will sit level in the trench. Excavate the trench carefully so that the surrounding soil is disturbed as little as possible. When using the mason's hammer, it is best to start by digging down several inches in one spot and then advancing the trench forward by chopping down on the soil. Do not pry the soil up as this tends to lift up large wedges of soil, opens cracks, and causes the trench to be oversized.

8.2.11 Place the inner ring in the trench to check the fit. Excavate any areas where the ring does not fit. Use a surveyor's level to check the elevation of the corners of the ring. The inner ring needs to be level or slightly tilted so that the back end is slightly lower than the front end.

8.2.12 Set the ring aside and cover the trenches.

NOTE 2—A chain saw that is equipped with a carbide-tipped chain and a bar may be used to excavate the trenches. Use of a chain saw will not only reduce the time needed to excavate the trench but will also greatly decrease the amount of grout needed to fill the trenches. If a chain saw is used, the trenches need only be 25 mm (1 in.) wide. A chain saw will not work well in some soils. A trial trench should be made to determine if it will work.

### 8.3 Installation of Rings:

8.3.1 Use the grout mixer to prepare enough grout to fill the trenches. The hydraulic conductivity of the grout should be less than approximately  $1 \times 10^{-8}$  m/s.

8.3.2 Fill the trenches to within 2.5 mm (1 in.) of the top of the trench. Rod or tamp the grout to remove any entrapped air.

8.3.3 Lift the inner ring and center it over the inner ring trench. Lower it into the trench and slowly push it down. Keep the ring level as it is pushed into place.

8.3.4 Use a surveyor's level to check that the ring is level.

8.3.5 Use a trowel to press the grout against the outside wall of the ring in order to ensure a good seal.

8.3.6 Cover the grout with plastic to prevent desiccation.

8.3.7 Lift the outer ring and center it over the outer ring trench.

8.3.8 Keep the ring level and push it into place.

8.3.9 Use the carpenter's level to make sure that the ring is level.

8.3.10 Use a trowel to push the grout against both the inside and the outside of the ring to ensure a good seal.

8.3.11 Cover the grout with plastic to prevent desiccation.

8.3.12 Place several cinder blocks between the inner and outer rings in the vicinity of the ports on the inner ring. These blocks will be used as a platform to stand on when connecting the fittings to the inner ring and also to support the flexible bags. The blocks should be no higher than 100 mm (4 in.)

8.3.13 Pile soil along the outside of the outer ring to a height of at least 30 cm (12 in.) This soil places an overburden pressure on the grout that will prevent it from being pushed out of the trench when the rings are filled with water.

### 8.4 Filling the Rings:

8.4.1 Fill two buckets with water and place one on each back corner of the inner ring. The buckets are placed on the inner ring to counteract the uplift force that acts on the ring as it is being filled. Make sure that the buckets are placed on the edge of the ring, not in the center as this may overstress the ring and cause it to crack. Do not to spill any water around the inner ring as this will make it difficult to check for leaks in the seal.

8.4.2 Place an empty bucket upside down on the ground near the top port on the inner ring. Place a second bucket on the first bucket. Fill the second bucket with water. Cut a length of the flexible tubing long enough to reach from the top bucket to the top port on the inner ring. Siphon the water from the bucket to the inner ring. Allow the siphoning to continue until the depth of the water in the inner ring is approximately 25 mm (1 in.). Avoid spilling any water around the inner ring during this filling process as this will make it difficult to check for leaks. Any other suitable method for adding the required volume of water to the inner ring may also be used.

8.4.3 Let the water stand in the inner ring for at least 30 min. Check for leaks in the inner ring seal and repair any that are found.

8.4.4 Start filling the outer ring slowly so as not to scour the soil and muddy the water. Direct the water so that it hits a splashboard first. Fill the outer ring until the water level is approximately 100 mm (4 in.) above the top of the inner ring. While the rings are being filled, use a board or shovel handle to gently tap the inner ring to dislodge air bubbles that are trapped inside. Continue tapping on the inner ring until bubbles cease to emerge from the top port.

8.4.5 Remove the buckets from the top of the inner ring.

### 8.5 Installation of Fittings and Tubing:

8.5.1 Wrap the threads of the two barbed fittings with TFE-fluorocarbon tape.

8.5.2 Saturate the fittings and connect them to the inner ring. Screw one of the barbed fittings into the top port and the other barbed fitting into one of the lower ports. Use caution when screwing the fittings into the ports as the threads in fiberglass inner rings can be easily damaged.

8.5.3 Cut two lengths of the clear flexible tubing, one 900-mm (3-ft) piece and one 1800-mm (6-ft) piece.

8.5.4 Saturate the tubing by placing it under water. Be sure to remove all air bubbles.

8.5.5 Connect one end of the 1.8-m (6-ft) piece to the fitting in the top port and seal the other end with a plug fitting. Do not let air into the tube during this process. This tube is the flush tube.

8.5.6 Connect the end of the 900-mm (3-ft) piece to the barbed fitting in the lower port. Prop the open end of this tube on the cinder block platform. Water is being drawn into this tube so be sure not to allow the open end of the tube to float to the surface and draw in air or sink to the bottom and draw in mud. This tube is the inlet tube.

### 8.6 *Covering the Rings:*

8.6.1 Cover the rings with either a tarp or plywood. The purpose of the cover is to minimize evaporation, minimize temperature changes, and inhibit the growth of algae.

8.6.2 Provide a means in the cover that makes it convenient to access the front of the inner ring to connect and disconnect the measurement bag.

### 8.7 *Maintaining the Water Level:*

8.7.1 Place a mark indicating the water elevation on the inside wall of the outer ring near the cinder blocks.

8.7.2 Observe the water level within the outer ring during the test and refill the ring to this mark before the water level drops more than 25 mm (1 in.) below the mark. Record the date, time, and the amount of water added.

8.8 *Purging the Inner Ring*—During the test, air may accumulate beneath the inner ring. This air may introduce error in flow measurements and consequently should be purged on a regular basis as follows.

8.8.1 Disconnect bag, if one is present, from end of inlet tube.

8.8.2 Lift the plugged end of the flush tube out of outer ring and below the water level in the outer ring so that water can be siphoned out of inner ring.

8.8.3 Remove plug from end of flush tube. Water and air if present will start to flow out of inner ring. If air completely fills the tube, the syphon will be lost. If this happens, saturate the tube and restart the syphon.

8.8.4 Allow water to flow from end of tube until air ceases to emerge from inner ring. Replace plug in end of flush tube and place tube back into outer ring. Note the approximate volume of purged air. Volume can be determined by multiplying the flow area of the flush tube by the height of the air bubbles which flow out of the tube.

8.8.5 Wait at least 30 min before taking any flow measurements.

8.8.6 Purge the inner ring on a weekly basis until no significant amount of air is found.

### 8.9 *Measurements:*

8.9.1 Attach the shut-off valve to the flexible bag and fill the bag with water. Remove all air bubbles from the bag. Use water that has been degassed or allow the bag to sit overnight so that the water can degas. If left to sit overnight, remove any air bubbles. Do not overfill the bag so that the water inside is under pressure.

8.9.2 Dry the outside of the bag and record its weight to the nearest gram.

8.9.3 With the shut-off valve closed, attach the bag to the open end of the inlet tube connected to the inner ring. Be sure not to trap any air bubbles in the inlet tubing or in the valve when attaching the bag. Lay the bag down on the cinder block platform.

8.9.4 Record the time, date, temperature of the water in the outer ring, and the depth of the water in the outer ring, and then carefully open the shut-off valve on the bag. Check that the inlet tube is not pinched and that the bag is arranged in such a manner that water can flow freely from it into the inner ring.

8.9.5 Sometime before the bag empties, close the shut-off valve, disconnect the bag from the inlet tube, and record the date, time, temperature of the water in the outer ring and the depth of the water in the outer ring. Be sure to prop the open end of the inlet hose as pointed out in 8.5.6. Do not leave the bag on long enough to empty as this will create a suction in the inner ring and cause leaks in the grout seal.

8.9.6 Dry the bag and record the weight of it to the nearest gram.

8.9.7 Refill the bag and repeat 8.9.2-8.9.6 until the infiltration rate (see Section 9) becomes steady or drops below a predetermined value.

NOTE 3—The reading times are governed primarily by the length of time the bag can remain connected to the inner ring without emptying. This length of time can only be determined through experience. Initially, flow rates will be high and the bag may need to be disconnected after several hours. As the test progresses, the flow rate will slow and the length of time it takes the bag to empty may increase to several days or weeks.

A second important factor that governs when readings should be made is the temperature of the water. In order to minimize the effects of temperature changes on the measured flow rate, the bag should be disconnected from the inner ring when the water is at the same temperature (within  $\pm 2^{\circ}\text{C}$ ) as when the bag was connected. More consistent readings are usually obtained if readings are made between 7 am and 9 am.

NOTE 4—It is not necessary to have the bag connected to the inner ring continuously. Flow only needs to be measured over timed intervals so that a plot of infiltration rate versus time can be constructed. The infiltration rate is not influenced by whether or not the bag is connected to the inlet tube. If the flow rate is high, it is more convenient to connect the bag to the inner ring for several hours a day and leave the inlet tube open in the outer ring for the remainder of the time.

NOTE 5—When connecting or disconnecting the bag from the inner ring, do not raise the bag above the level of the water in the outer ring with the shut-off valve open. This would cause an uplift force to act on the inner ring and could cause it to rise out of the trench.

### 8.10 *Ending Test:*

8.10.1 Remove the fittings and tubing from the inner ring.

8.10.2 Drain water from rings.

8.10.3 Excavate the grout from around the rings and pull the rings out of the ground.

8.10.4 Excavate a narrow trench in the area encompassed by the inner ring and take moisture content samples every 25 mm (1 in.) to a depth of 150 mm (6 in.) below the observed wetting front. An alternative to this is to push a thin-walled sampling tube into the soil, extrude the soil, and slice it every 25 mm (1 in.) for moisture content samples.

## 9. Calculation

9.1 Calculate the infiltration rate for each timed interval as follows:

$$I \text{ (m/s)} = \frac{Q}{tA} \times 10^{-6} \quad (1)$$

where:

$Q$  = volume of flow, mL,

=  $W_1 - W_2$

$W_1$  = initial weight of bag, g,

$W_2$  = final weight of bag, g,



**SUMMARY OF CHANGES**

In accordance with Committee D18 policy, this section identifies the location of changes to this standard since the 1990(1997) edition.

- (1) Requirement to follow Practice D 6026 added to Section 1.      (3) Added Practices D 3740 and D 6026 to Section 2.  
(2) Standard note regarding quality of test results add to  
Section 5.

*ASTM International takes no position respecting the validity of any patent rights asserted in connection with any item mentioned in this standard. Users of this standard are expressly advised that determination of the validity of any such patent rights, and the risk of infringement of such rights, are entirely their own responsibility.*

*This standard is subject to revision at any time by the responsible technical committee and must be reviewed every five years and if not revised, either reapproved or withdrawn. Your comments are invited either for revision of this standard or for additional standards and should be addressed to ASTM International Headquarters. Your comments will receive careful consideration at a meeting of the responsible technical committee, which you may attend. If you feel that your comments have not received a fair hearing you should make your views known to the ASTM Committee on Standards, at the address shown below.*

*This standard is copyrighted by ASTM International, 100 Barr Harbor Drive, PO Box C700, West Conshohocken, PA 19428-2959, United States. Individual reprints (single or multiple copies) of this standard may be obtained by contacting ASTM at the above address or at 610-832-9585 (phone), 610-832-9555 (fax), or [service@astm.org](mailto:service@astm.org) (e-mail); or through the ASTM website ([www.astm.org](http://www.astm.org)).*