



Designation: D 698 – 00a^{ε1}

Standard Test Methods for Laboratory Compaction Characteristics of Soil Using Standard Effort (12,400 ft-lbf/ft³(600 kN-m/m³))¹

This standard is issued under the fixed designation D 698; the number immediately following the designation indicates the year of original adoption or, in the case of revision, the year of last revision. A number in parentheses indicates the year of last reapproval. A superscript epsilon (ϵ) indicates an editorial change since the last revision or reapproval.

^{ε1} NOTE—Paragraph 10.4.3 was corrected editorially in November 2003.

1. Scope*

1.1 ~~These~~ test methods covers laboratory compaction ~~procedures~~ methods used to determine the relationship between water content and dry unit weight of soils (compaction curve) compacted in a 4 or 6-in. (101.6 or 152.4-mm) diameter mold with a 5.5-lbf (24.4-N) rammer dropped from a height of 12 in. (305 mm) producing a compactive effort of 12,400 ft-lbf/ft³(600 kN-m/m³).

NOTE 1—The equipment and procedures are similar as those proposed by R. R. Proctor (*Engineering News Record*—September 7, 1933) with this one major exception: his rammer blows were applied as “12 inch firm strokes” instead of free fall, producing variable compactive effort depending on the operator, but probably in the range 15,000 to 25,000 ft-lbf/ft³ (700 to 1,200 kN-m/m³). The standard effort test (see 3.2.2) is sometimes referred to as the Proctor Test.

NOTE 2—Soils and soil-aggregate mixtures should be regarded as natural occurring fine- or coarse-grained soils or composites or mixtures of natural soils, or mixtures of natural and processed soils or aggregates such as silt, gravel, or crushed rock.

1.2 ~~These~~ test methods applies only to soils (materials) that have 30 % or less by weight mass of particles retained on the ¾-inch (19.0-mm) sieve.

NOTE 3—For relationships between unit weights and water contents of soils with 30 % or less by weight mass of material retained on the ¾-in. (19.0-mm) sieve to unit weights and water contents of the fraction passing ¾-in. (19.0-mm) sieve, see Practice D 4718.

1.3 Three alternative ~~procedures~~ methods are provided. The ~~procedure~~ method used shall be as indicated in the specification for the material being tested. If no ~~procedure~~ method is specified, the choice should be based on the material gradation.

1.3.1 ~~Procedure~~Method A:

1.3.1.1 *Mold*—4-in. (101.6-mm) diameter.

1.3.1.2 *Material*—Passing No. 4 (4.75-mm) sieve.

1.3.1.3 *Layers*—Three.

1.3.1.4 *Blows per layer*—25.

1.3.1.5 *Use*—May be used if 20 % or less by weight mass of the material is retained on the No. 4 (4.75-mm) sieve.

1.3.1.6 *Other Use*—If this ~~procedure~~ method is not specified, materials that meet these gradation requirements may be tested using ~~Procedures~~ Methods B or C.

1.3.2 ~~Procedure~~Method B:

1.3.2.1 *Mold*—4-in. (101.6-mm) diameter.

1.3.2.2 *Material*—Passing ⅜-in. (9.5-mm) sieve.

1.3.2.3 *Layers*—Three.

1.3.2.4 *Blows per layer*—25.

1.3.2.5 *Use*—Shall be used if more than 20 % by weight mass of the material is retained on the No. 4 (4.75-mm) sieve and 20 % or less by weight mass of the material is retained on the ⅜-in. (9.5-mm) sieve.

1.3.2.6 *Other Use*—If this ~~procedure~~ method is not specified, materials that meet these gradation requirements may be tested using ~~Procedure~~ Method C.

1.3.3 ~~Procedure~~Method C:

1.3.3.1 *Mold*—6-in. (152.4-mm) diameter.

1.3.3.2 *Material*—Passing ¾-inch (19.0-mm) sieve.

1.3.3.3 *Layers*—Three.

¹ This ~~test method~~ standard is under the jurisdiction of ASTM Committee D18 on Soil and Rock and is the direct responsibility of Subcommittee D18.03 on Texture, Plasticity and Density Characteristics of Soils.

Current edition approved ~~March~~ June 10, 2000. Published ~~August~~ September 2000. Originally published as D 698 – 91~~42T~~. Last previous edition ~~D 698 – 91 (1998)~~: D 698 – 00.

*A Summary of Changes section appears at the end of this standard.

1.3.3.4 *Blows per layer*—56.

1.3.3.5 *Use*—Shall be used if more than 20 % by weight mass of the material is retained on the $\frac{3}{8}$ -in. (9.5-mm) sieve and less than 30 % by weight mass of the material is retained on the $\frac{3}{4}$ -in. (19.0-mm) sieve.

1.3.4 The 6-in. (152.4-mm) diameter mold shall not be used with Procedure Method A or B.

NOTE 4—Results have been found to vary slightly when a material is tested at the same compactive effort in different size molds.

1.4 If the test specimen contains more than 5 % by weight mass of oversize fraction (coarse fraction) and the material will not be included in the test, corrections must be made to the unit weight mass and water content of the specimen or to the appropriate field in place density test specimen using Practice D 4718.

1.5 This test method will generally produce a well defined maximum dry unit weight for non-free draining soils. If this test method is used for free draining soils the maximum unit weight may not be well defined, and can be less than obtained using Test Methods D 4253.

1.6 The values in inch-pound units are to be regarded as the standard. The values stated in SI units are provided for information only.

1.6.1 In the engineering profession it is customary practice to use, interchangeably, units representing both mass and force, unless dynamic calculations ($F = Ma$) are involved. This implicitly combines two separate systems of units, that is, the absolute system and the gravimetric system. It is scientifically undesirable to combine the use of two separate systems within a single standard. This test method has been written using inch-pound units (gravimetric system) where the pound (lbf) represents a unit of force. The use of mass (lbm) is for convenience of units and is not intended to convey the use is scientifically correct. Conversions are given in the SI system in accordance with IEEE/ASTM SI 10. The use of balances or scales recording pounds of mass (lbm), or the recording of density in lbm/ft³ should not be regarded as nonconformance with this standard.

1.7 *This standard does not purport to address all of the safety concerns, if any, associated with its use. It is the responsibility of the user of this standard to establish appropriate safety and health practices and determine the applicability of regulatory limitations prior to use.*

2. Referenced Documents

2.1 *ASTM Standards:*

C 127 Test Method for Specific Gravity and Absorption of Coarse Aggregate²

C 136 Method for Sieve Analysis of Fine and Coarse Aggregate²

D 422 Test Method for Particle Size Analysis of Soils³

D 653 Terminology Relating to Soil, Rock, and Contained Fluids³

D 854 Test Methods for Specific Gravity of Soil Solids by Water Pycnometer³

D 1557 Test Methods for ~~Moisture-Density Relations~~ Laboratory Compaction Characteristics of Soils and Soil-Aggregate Mixtures Using 10-lb (4.54-kg.) Rammer and 18-in. (457 mm) Modified Efforts (56,000 ft-lbf/ft³ (2,700 kN-m/m³)) Drop³

D 2168 Test Methods for Calibration of Laboratory Mechanical-Rammer Soil Compactors³

D 2216 Test Method for Laboratory Determination of Water (Moisture) Content of ~~Soil, Rock Soil and Soil-Aggregate Mixtures~~ Rock by Mass³

~~D 2487 Test Method~~ 2487 Practice for Classification of Soils for Engineering Purposes (Unified Soil Classification System)³

D 2488 Practice for Description and Identification of Soils (Visual-Manual Procedure)³

D 3740 Practice for Minimum Requirements for Agencies Engaged in the Testing and/or Inspection of Soil and Rock as Used in Engineering Design and Construction³

D 4220 Practices for Preserving and Transporting Soil Samples³

D 4253 Test Methods for Maximum Index Density and Unit Weight of Soils Using a Vibratory Table³

D 4718 Practice for Correction of Unit Weight and Water Content for Soils Containing Oversize Particles³

D 4753 Specification for Evaluating, Selecting and Specifying Balances and Scales For Use in Soil, Rock, and ~~Rock~~ Construction Materials Testing³

D 4914 Test Methods for Density of Soil and Rock in Place by the Sand Replacement Method in a Test Pit³

D 5030 Test Method for Density of Soil and Rock in Place by the Water Replacement Method in a Test Pit³

D 6026 Practice for Using Significant Digits in Geotechnical Data⁴

E 1 Specification for ASTM Thermometers⁵

E 11 Specification for Wire-Cloth Sieves for Testing Purposes⁶

E 31977 Practice for Use of the Terms Precision and Bias in ASTM Test Methods⁷

² Annual Book of ASTM Standards, Vol 04.02.

³ Annual Book of ASTM Standards, Vol 04.08.

⁴ Annual Book of ASTM Standards, Vol 04.09.

⁵ Annual Book of ASTM Standards, Vol 14.03.

⁶ Annual Book of ASTM Standards, Vol 14.02.

⁷ The boldface numbers in parentheses refer to the list

E 319 Practice for the Evaluation of Single-Pan Mechanical Balances⁶

E 691 Practice for Conducting an Interlaboratory Study to Determine the Precision of a Test Method⁶

IEEE/ASTM SI 10 -Standard for Use of the International System of Units (SI): the Modern Metric System⁸

3. Terminology

3.1 *Definitions:* See Terminology D 653 for general definitions.

3.2 *Description of Terms Specific to This Standard:*

3.2.1 *oversize fraction (coarse fraction), P_c* in %—the portion of total sample not used in performing the compaction test; it may be the portion of total sample retained on the No. 4 (4.75-mm), $\frac{3}{8}$ -in. (9.5-mm), or $\frac{3}{4}$ -in. (19.0-mm) sieve.

3.2.2 *standard effort*—the term for the 12,400 ft-lbf/ft³ (600 kN-m/m³) compactive effort applied by the equipment and procedures methods of this test.

3.2.3 *standard maximum dry unit weight, γ_{dmax}* in lbf/ft³ (kN/m³)—the maximum value defined by the compaction curve for a compaction test using standard effort.

3.2.4 *standard optimum water content, w_o* in %— the water content at which a soil can be compacted to the maximum dry unit weight using standard compactive effort.

3.2.5 *test fraction (finer fraction), P_F* in %—the portion of the total sample used in performing the compaction test; it is the fraction passing the No. 4 (4.75-mm) sieve in Procedure Method A, minus $\frac{3}{8}$ -in. (9.5-mm) sieve in Procedure Method B, or minus $\frac{3}{4}$ -in. (19.0-mm) sieve in Procedure Method C.

4. Summary of Test Method

4.1 A soil at a selected water content is placed in three layers into a mold of given dimensions, with each layer compacted by 25 or 56 blows of a 5.5-lbf (24.4-N) rammer dropped from a distance of 12-in. (305-mm), subjecting the soil to a total compactive effort of about 12,400 ft-lbf/ft³ (600 kN-m/m³). The resulting dry unit weight is determined. The procedure is repeated for a sufficient number of water contents to establish a relationship between the dry unit weight and the water content for the soil. This data, when plotted, represents a curvilinear relationship known as the compaction curve. The values of optimum water content and standard maximum dry unit weight are determined from the compaction curve.

5. Significance and Use

5.1 Soil placed as engineering fill (embankments, foundation pads, road bases) is compacted to a dense state to obtain satisfactory engineering properties such as, shear strength, compressibility, or permeability. Also, foundation soils are often compacted to improve their engineering properties. Laboratory compaction tests provide the basis for determining the percent compaction and water content needed to achieve the required engineering properties, and for controlling construction to assure that the required compaction and water contents are achieved.

5.2 During design of an engineered fill, shear, consolidation, permeability, or other tests require preparation of test specimens by compacting at some water content to some unit weight. It is common practice to first determine the optimum water content (w_o) and maximum dry unit weight (γ_{dmax}) by means of a compaction test. Test specimens are compacted at a selected water content (w), either wet or dry of optimum (w_o) or at optimum (w_o), and at a selected dry unit weight related to a percentage of maximum dry unit weight (γ_{dmax}). The selection of water content (w), either wet or dry of optimum (w_o) or at optimum (w_o) and the dry unit weight (γ_{dmax}) may be based on past experience, or a range of values may be investigated to determine the necessary percent of compaction.

5.3 Experience indicates that the methods outlined in 5.2 or the construction control aspects discussed in 5.1 are extremely difficult to implement or yield erroneous results when dealing with certain soils. 5.3.1-5.3.3 describe typical problem soils, the problems encountered when dealing with such soils and possible solutions for these problems.

5.3.1 *Oversize Fraction*—Soils containing more than 30 % oversize fraction (material retained on the $\frac{3}{4}$ -in. (19-mm) sieve) are a problem. For such soils, there is no ASTM test method to control their compaction and very few laboratories are equipped to determine the laboratory maximum unit weight (density) of such soils (USDI Bureau of Reclamation, Denver, CO and U.S. Army Corps of Engineers, Vicksburg, MS). Although Test Methods D 4914 and D 5030 determine the “field” dry unit weight of such soils, they are difficult and expensive to perform.

5.3.1.1 One method to design and control the compaction of such soils is to use a test fill to determine the required degree of compaction and the method to obtain that compaction, followed by use of a method specification to control the compaction. Components of a method specification typically contain the type and size of compaction equipment to be used, the lift thickness, and the number of passes.

NOTE 5—Success in executing the compaction control of an earthwork project, especially when a method specification is used, is highly dependent upon the quality and experience of the “contractor” and “inspector.”

⁷ Annual Book of references at the end of this standard. ASTM Standards, Vol 15.09.

⁸ Annual Book of ASTM Standards, Vol 14.04.

5.3.1.2 Another method is to apply the use of density correction factors developed by the USDI Bureau of Reclamation (1,2)⁹ and U.S. Corps of Engineers (3). These correction factors may be applied for soils containing up to about 50 to 70 % oversize fraction. Each agency uses a different term for these density correction factors. The USDI Bureau of Reclamation uses *D* ratio (or *D* – VALUE), while the U.S. Corps of Engineers uses Density Interference Coefficient (*I_c*).

5.3.1.3 The use of the replacement technique (Test Method D 698–78, Method D), in which the oversize fraction is replaced with a finer fraction, is inappropriate to determine the maximum dry unit weight, γ_{dmax} , of soils containing oversize fractions (3).

5.3.2 *Degradation*— Soils containing particles that degrade during compaction are a problem, especially when more degradation occurs during laboratory compaction than field compaction, as is typical. Degradation typically occurs during the compaction of a granular-residual soil or aggregate. When degradation occurs, the maximum dry-unit weight increases (4) so that the laboratory maximum value is not representative of field conditions. Often, in these cases, the maximum dry unit weight is impossible to achieve in the field.

5.3.2.1 Again, for soils subject to degradation, the use of test fills and method specifications may help. Use of replacement techniques is not correct.

5.3.3 *Gap Graded*—Gap-graded soils (soils containing many large particles with limited small particles) are a problem because the compacted soil will have larger voids than usual. To handle these large voids, standard test methods (laboratory or field) typically have to be modified using engineering judgement.

NOTE 6—The quality of the result produced by this standard is dependent on the competence of the personnel performing it, and the suitability of the equipment and facilities used. Agencies that meet the criteria of Practice D 3740 are generally considered capable of competent and objective testing/sampling/inspection, and the like. Users of this standard are cautioned that compliance with Practice D 3740 does not in itself assure reliable results. Reliable results depend on many factors; Practice D 3740 provides a means of evaluating some of those factors.

6. Apparatus

6.1 *Mold Assembly* — The molds shall be cylindrical in shape, made of rigid metal and be within the capacity and dimensions indicated in 6.1.1 or 6.1.2 and Fig. 1 and Fig. 2. See also Table 1. The walls of the mold may be solid, split, or tapered. The “split” type may consist of two half-round sections, or a section of pipe split along one element, which can be securely locked together to form a cylinder meeting the requirements of this section. The “tapered” type shall an internal diameter taper that is uniform and not more than 0.200 in./ft (16.7- mm/m) of mold height. Each mold shall have a base plate and an extension collar assembly, both made of rigid metal and constructed so they can be securely attached and easily detached from the mold. The extension collar assembly shall have a height extending above the top of the mold of at least 2.0 in. (50.8-mm) which may include an upper section that flares out to form a funnel provided there is at least a 0.75 in. (19.0-mm) straight cylindrical section beneath it. The extension collar shall align with the inside of the mold. The bottom of the base plate and bottom of the centrally recessed area that accepts the cylindrical mold shall be planar.

6.1.1 *Mold, 4 in.*— A mold having a 4.000 ± 0.016 -in. (101.6 ± 0.4 -mm) average inside diameter, a height of 4.584 ± 0.018 -in. (116.4 ± 0.5 - mm) and a volume of 0.0333 ± 0.0005 ft³ (944 ± 14 cm³). A mold assembly having the minimum required features is shown in Fig. 1.

6.1.2 *Mold, 6 in.* — A mold having a 6.000 ± 0.026 -in. (152.4 ± 0.7 -mm) average inside diameter, a height of 4.584 ± 0.018 -in. (116.4 ± 0.5 - mm), and a volume of 0.075 ± 0.0009 ft³ (2124 ± 25 cm³). A mold assembly having the minimum required features is shown in Fig. 2.

6.2 *Rammer*—A rammer, either manually operated as described further in 6.2.1 or mechanically operated as described in 6.2.2. The rammer shall fall freely through a distance of 12 ± 0.05 - in. (304.8 ± 1.3 - mm) from the surface of the specimen. The mass of the rammer shall be 5.5 ± 0.02 - lbm (2.5 ± 0.01 - kg), except that the mass of the mechanical rammers may be adjusted as

⁹ The boldface numbers in parentheses refer to the list of references at the end of this standard.

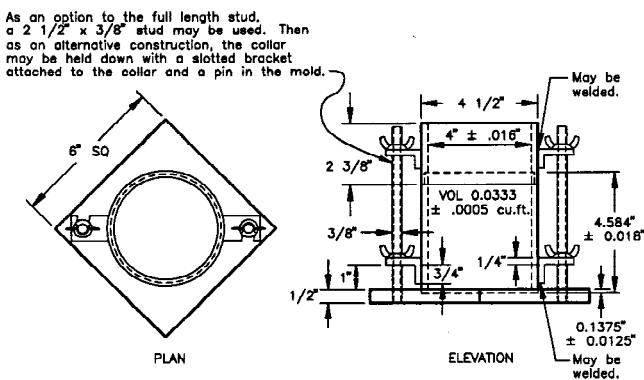

FIG. 1 4.0-in. Cylindrical Mold

As an option to the full length stud, a 2 1/2" x 3/8" stud may be used. Then as an alternative construction, the collar may be held down with a slotted bracket attached to the collar and a pin in the mold.

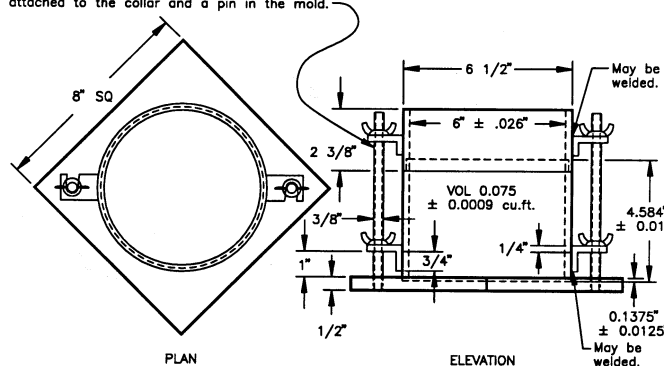

FIG. 2 6.0-in. Cylindrical Mold

TABLE 1 RMetric Equired Stvanding Timlents o f Moistur Fized Specimengs. 1 and 2

Classification	Minimum Standing Time, h
GW, GP, SW, SP	No Requirement
0.016	0.41
GM, SM	0.66
0.026	0.66
0.032	0.81
0.028	0.71
1/2	12.70
2 1/2	63.50
2 5/8	66.70
4	101.60
4 1/2	114.30
4.584	116.43
4 3/4	120.60
6	152.40
6 1/2	165.10
6 5/8	168.30
6 3/4	171.40
8 1/4	209.60
ft ³	cm ³
1/30 (0.0333)	943
0.0005	3
All other soils	1624
(0.0750)	2,124
0.0011	31

described in Test Methods D 2168; see Note 6.7. The striking face of the rammer shall be planar and circular, except as noted in 6.2.2.1, with a diameter when new of 2.000 ± 0.005 in. (50.80 ± 0.13 mm). The rammer shall be replaced if the striking face becomes worn or bellied to the extent that the diameter exceeds 2.000 ± 0.01 in. (50.80 ± 0.25 mm).

NOTE 67—It is a common and acceptable practice in the inch-pound system to assume that the mass of the rammer is equal to its mass determined using either a kilogram or pound balance and 1 lbf is equal to 1 lbm or 0.4536 kg, or 1 N is equal to 0.2248 lbm or 0.1020 kg.

6.2.1 *Manual Rammer*—The rammer shall be equipped with a guide sleeve that has sufficient clearance that the free fall of the rammer shaft and head is not restricted. The guide sleeve shall have at least four vent holes at each end (eight holes total) located with centers 3/4 ± 1/16 in. (19.0 ± 1.6 mm) from each end and spaced 90 degrees apart. The minimum diameter of the vent holes shall be 3/8 in. (9.5 mm). Additional holes or slots may be incorporated in the guide sleeve.

6.2.2 *Mechanical Rammer-Circular Face*—The rammer shall operate mechanically in such a manner as to provide uniform and complete coverage of the specimen surface. There shall be 0.10 ± 0.03 in. (2.5 ± 0.8 mm) clearance between the rammer and the inside surface of the mold at its smallest diameter. The mechanical rammer shall meet the calibration requirements of Test Methods D 2168. The mechanical rammer shall be equipped with a positive mechanical means to support the rammer when not in operation.

6.2.2.1 *Mechanical Rammer-Sector Face*—When used with the 6-in. (152.4 mm) mold, a sector face rammer may be used in place of the circular face rammer. The specimen contact face shall have the shape of a sector of a circle of radius equal to 2.90 ± 0.02 in. (73.7 ± 0.5 mm). The rammer shall operate in such a manner that the vertex of the sector is positioned at the center of the specimen.

6.3 *Sample Extruder (optional)*—A jack, frame or other device adapted for the purpose of extruding compacted specimens from the mold.

6.4 *Balance*—A class GP5 balance meeting the requirements of Specification D 4753 for a balance of 1-g readability.

6.5 *Drying Oven*—Thermostatically controlled, preferably of a forced-draft type and capable of maintaining a uniform temperature of $230 \pm 9^\circ\text{F}$ ($110 \pm 5^\circ\text{C}$) throughout the drying chamber.

6.6 *Straightedge*—A stiff metal straightedge of any convenient length but not less than 10-in. (254-mm). The total length of the straightedge shall be machined straight to a tolerance of ± 0.005 -in. (± 0.1 -mm). The scraping edge shall be beveled if it is thicker than $\frac{1}{8}$ -in. (3-mm).

6.7 *Sieves*— $\frac{3}{4}$ -in. (19.0-mm), $\frac{3}{8}$ -in. (9.5-mm), and No. 4 (4.75-mm), conforming to the requirements of Specification E 11.

6.8 *Mixing Tools*—Miscellaneous tools such as mixing pan, spoon, trowel, spatula, etc., or a suitable mechanical device for thoroughly mixing the sample of soil with increments of water.

7. Calibration

7.1 Perform calibrations before initial use, after repairs or other occurrences that might affect the test results, at intervals not exceeding 1,000 test specimens, or annually, whichever occurs first, for the following apparatus:

7.1.1 *Balance*—Evaluate in accordance with Specification D 4753.

7.1.2 *Molds*—Determine the volume as described in Annex A1.

7.1.3 *Manual Rammer*—Verify the free fall distance, rammer mass, and rammer face in accordance with 6.2. Verify the guide sleeve requirements in accordance with 6.2.1.

7.1.4 *Mechanical Rammer*—Calibrate and adjust the mechanical rammer in accordance with Test Methods D 2168. In addition, the clearance between the rammer and the inside surface of the mold shall be verified in accordance with 6.2.2.

8. Test Sample

8.1 The required sample mass for ~~Procedures Methods~~ Methods A and B is approximately 35-lbm (16-kg), and for ~~Procedure Method~~ Method C is approximately 65-lbm (29-kg) of dry soil. Therefore, the field sample should have a moist mass of at least 50-lbm (23-kg) and 100-lbm (45-kg), respectively.

8.2 Determine the percentage of material (by mass) retained on the No. 4 (4.75-mm), $\frac{3}{8}$ -in. (9.5-mm), or $\frac{3}{4}$ -in. (19.0-mm) sieve as appropriate for choosing ~~Procedure Method~~ A, B, or C. Make this determination by separating out a representative portion from the total sample and determining the percentages passing the sieves of interest by Test Methods D 422 or Method C 136. It is only necessary to calculate percentages for the sieve or sieves for which information is desired.

9. Preparation of Apparatus

9.1 Select the proper compaction mold in accordance with the ~~procedure Method~~ Method (A, B, or C) being used. Determine and record its mass to the nearest gram. Assemble the mold, base and extension collar. Check the alignment of the inner wall of the mold and mold extension collar. Adjust if necessary.

9.2 Check that the rammer assembly is in good working condition and that parts are not loose or worn. Make any necessary adjustments or repairs. If adjustments or repairs are made, the rammer must be recalibrated.

10. Procedure

10.1 Soils:

10.1.1 Do not reuse soil that has been previously ~~laboratory compacted~~ compacted in the laboratory.

10.1.2 When using this test method for soils containing hydrated halloysite, or where past experience with a particular soil indicates that results will be altered by air drying, use the moist preparation method (see 10.2).

10.1.3 Prepare the soil specimens for testing in accordance with 10.2 (preferred) or with 10.3.

10.2 *Moist Preparation Method (preferred)*—Without previously drying the sample, pass it through a No. 4 (4.75-mm), $\frac{3}{8}$ -in. (9.5-mm), or $\frac{3}{4}$ -in. (19.0-mm) sieve, depending on the ~~procedure Method~~ Method (A, B, or C) being used. Determine the water content of the processed soil.

10.2.1 Prepare at least four (preferably five) specimens having water contents such that they bracket the estimated optimum water content. A specimen having a water content close to optimum should be prepared first by trial additions of water and mixing (see Note 7~~8~~, 8). Select water contents for the rest of the specimens to provide at least two specimens wet and two specimens dry of optimum, and water contents varying by about 2%. At least two water contents are necessary on the wet and dry side of optimum to accurately define the dry unit weight compaction curve (see 10.5). Some soils with very high optimum water content or a relatively flat compaction curve may require larger water content increments to obtain a well defined maximum dry unit weight. Water content increments should not exceed 4%.

NOTE 7~~8~~—With practice it is usually possible to visually judge a point near optimum water content. Typically, soil at optimum water content can be squeezed into a lump that sticks together when hand pressure is released, but will break cleanly into two sections when “bent”. At water contents dry of optimum soils tend to crumble; wet of optimum soils tend to stick together in a sticky cohesive mass. Optimum water content is typically slightly less than the plastic limit.

10.2.2 Use approximately 5-lbm (2.3-kg) of the sieved soil for each specimen to be compacted using ~~Procedure Method~~ Method A or

B, or 13-lbm (5.9-kg) using Procedure Method C. To obtain the specimen water contents selected in 10.2.1, add or remove the required amounts of water as follows: to add water, spray it into the soil during mixing; to remove water, allow the soil to dry in air at ambient temperature or in a drying apparatus such that the temperature of the sample does not exceed 140°F (60°C). Mix the soil frequently during drying to maintain an even water content distribution. Thoroughly mix each specimen to ensure even distribution of water throughout and then place in a separate covered container and allow to stand in accordance with Table 1 prior to compaction. For the purpose of selecting a standing time, the soil may be classified using Test Method D 2487, Practice D 2488 or data on other samples from the same material source. For referee testing, classification shall be by Test Method D 2487, 2 prior to compaction. For the purpose of selecting a standing time, the soil may be classified using Test Method D 2487, Practice D 2488 or data on other samples from the same material source. For referee testing, classification shall be by Test Method D 2487.

10.3 *Dry Preparation Method*—If the sample is too damp to be friable, reduce the water content by air drying until the material is friable. Drying may be in air or by the use of drying apparatus such that the temperature of the sample does not exceed 140°F (60°C). Thoroughly break up the aggregations in such a manner as to avoid breaking individual particles. Pass the material through the appropriate sieve: No. 4 (4.75-mm), 3/8-in. (9.5-mm), or 3/4-in. (19.0-mm). When preparing the material by passing over the 3/4-in. sieve for compaction in the 6-in. mold, break up aggregations sufficiently to at least pass the 3/8-in. sieve in order to facilitate the distribution of water throughout the soil in later mixing.

10.3.1 Prepare at least four (preferably five) specimens in accordance with 10.2.1.

10.3.2 Use approximately 5-lbm (2.3-kg) of the sieved soil for each specimen to be compacted using Procedure Method A or B, or 13-lbm (5.9-kg) using Procedure Method C. Add the required amounts of water to bring the water contents of the specimens to the values selected in 10.3.1. Follow the specimen preparation procedure method specified in 10.2.2 for drying the soil or adding water into the soil and curing each test specimen.

10.4 *Compaction*—After curing, if required, each specimen shall be compacted as follows:

10.4.1 Determine and record the mass of the mold or mold and base plate.

10.4.2 Assemble and secure the mold and collar to the base plate. The mold shall rest on a uniform rigid foundation, such as provided by a cylinder or cube of concrete with a mass of not less than 200-lbm (91-kg). Secure the base plate to the rigid foundation. The method of attachment to the rigid foundation shall allow easy removal of the assembled mold, collar and base plate after compaction is completed.

10.4.3 Compact the specimen in three layers. After compaction, each layer should be approximately equal in thickness. Prior to compaction, place the loose soil into the mold and spread into a layer of uniform thickness. Lightly tamp the soil prior to compaction until it is not in a fluffy or loose state, using either the manual compaction rammer or a 2-in. (50.8-mm) diameter cylinder. Following compaction of each of the first two layers, any soil adjacent to the mold walls that has not been compacted or extends above the compacted surface shall be trimmed. The trimmed soil may be included with the additional soil for the next layer. A knife or other suitable device may be used. The total amount of soil used shall be such that the third compacted layer slightly extends into the collar, but does not exceed 1/4-in. (6-mm) above the top of the mold. If the third layer does extend above the top of the mold by more than 1/4-in. (6-mm), the specimen shall be discarded. The specimen shall be discarded when the last

TABLE 2 Minimum Equivalent Standing Times of Moisturized Specimens

Classification	Minimum Standing Time, h
0.016 GW, GP, SW, SP	0.41 No Requirement
0.026 GM, SM	—0.66 —0.66
0.032 0.028	—0.84 —0.74
1/2	—12.70
2 1/2	—63.50
2 5/8	—66.70
4	101.60
4 1/2	114.30
4.584	116.43
4 3/4	120.60
6	152.40
6 1/2	165.10
6 5/8	168.30
6 3/4	174.40
8 1/4	209.60
ft ³	cm ³
1/30 (0.0333)	943
0.0005 (0.0750)	14 2,124
All other soils	124
0.0011	—34
0.0011	316

blow on the rammer for the third layer results in the bottom of the rammer extending below the top of the compaction mold.

10.4.4 Compact each layer with 25 blows for the 4-in. (101.6-mm) mold or with 56 blows for the 6-in. (152.4-mm) mold.

NOTE 89—When compacting specimens wetter than optimum water content, uneven compacted surfaces can occur and operator judgement is required as to the average height of the specimen.

10.4.5 In operating the manual rammer, take care to avoid lifting the guide sleeve during the rammer upstroke. Hold the guide sleeve steady and within 5° of vertical. Apply the blows at a uniform rate of approximately 25 blows/min and in such a manner as to provide complete, uniform coverage of the specimen surface.

10.4.6 Following compaction of the last layer, remove the collar and base plate from the mold, except as noted in 10.4.7. A knife may be used to trim the soil adjacent to the collar to loosen the soil from the collar before removal to avoid disrupting the soil below the top of the mold.

10.4.7 Carefully trim the compacted specimen even with the top of the mold by means of the straightedge scraped across the top of the mold to form a plane surface even with the top of the mold. Initial trimming of the specimen above the top of the mold with a knife may prevent the soil from tearing below the top of the mold. Fill any holes in the top surface with unused or trimmed soil from the specimen, press in with the fingers, and again scrape the straightedge across the top of the mold. Repeat the appropriate preceding operations on the bottom of the specimen when the mold volume was determined without the base plate. For very wet or dry soils, soil or water may be lost if the base plate is removed. For these situations, leave the base plate attached to the mold. When the base plate is left attached, the volume of the mold must be calibrated with the base plate attached to the mold rather than a plastic or glass plate as noted in Annex A1, A1.4.

10.4.8 Determine and record the mass of the specimen and mold to the nearest gram. When the base plate is left attached, determine and record the mass of the specimen, mold and base plate to the nearest gram.

10.4.9 Remove the material from the mold. Obtain a specimen for water content by using either the whole specimen (preferred method) or a representative portion. When the entire specimen is used, break it up to facilitate drying. Otherwise, obtain a portion by slicing the compacted specimen axially through the center and removing about 500-g of material from the cut faces. Obtain the water content in accordance with Test Method D 2216.

10.5 Following compaction of the last specimen, compare the wet unit weights to ensure that a desired pattern of obtaining data on each side of the optimum water content will be attained for the dry unit weight compaction curve. Plotting the wet unit weight and water content of each compacted specimen can be an aid in making the above evaluation. If the desired pattern is not obtained, additional compacted specimens will be required. Generally, one water content value wet of the water content defining the maximum wet unit weight is sufficient to ensure data on the wet side of optimum water content for the maximum dry unit weight.

11. Calculation

11.1 Calculate the dry unit weight and water content of each compacted specimen as explained in 11.3 and 11.4. Plot the values and draw the compaction curve as a smooth curve through the points (see example, Fig. 3). Plot dry unit weight to the nearest 0.1 lbf/ft³ (0.2 kN/m³) and water content to the nearest 0.1 %. From the compaction curve, determine the optimum water content and maximum dry unit weight. If more than 5 % by ~~weight~~ mass of oversize material was removed from the sample, calculate the corrected optimum water content and maximum dry unit weight of the total material using Practice D 4718. This correction may be made to the appropriate field in place density test specimen rather than to the laboratory test specimen.

11.2 Plot the 100 % saturation curve. Values of water content for the condition of 100 % saturation can be calculated as explained in 11.5 (see example, Fig. 3).

NOTE 910—The 100 % saturation curve is an aid in drawing the compaction curve. For soils containing more than approximately 10 % fines at water contents well above optimum, the two curves generally become roughly parallel with the wet side of the compaction curve between 92 % to 95 % saturation. Theoretically, the compaction curve cannot plot to the right of the 100 % saturation curve. If it does, there is an error in specific gravity, in measurements, in calculations, in ~~test procedures~~, testing, or in plotting.

NOTE 101—The 100 % saturation curve is sometimes referred to as the zero air voids curve or the complete saturation curve.

11.3 *Water Content, w*—Calculate in accordance with Test Method D 2216.

11.4 *Dry Unit Weights*—Calculate the moist density (Eq 1), the dry density (Eq 2), and then the dry unit weight (Eq 3) as follows:

$$\rho_m = \frac{(M_t - M_{md})}{1000 V} \quad (1)$$

where:

ρ_m = moist density of compacted specimen, Mg/m³,

M_t = mass of moist specimen and mold, kg,

M_{md} = mass of compaction mold, kg, and

V = volume of compaction mold, m³ (see Annex A1)

$$\rho_d = \frac{\rho_m}{1 + w/100} \quad (2)$$

COMPACTION TEST

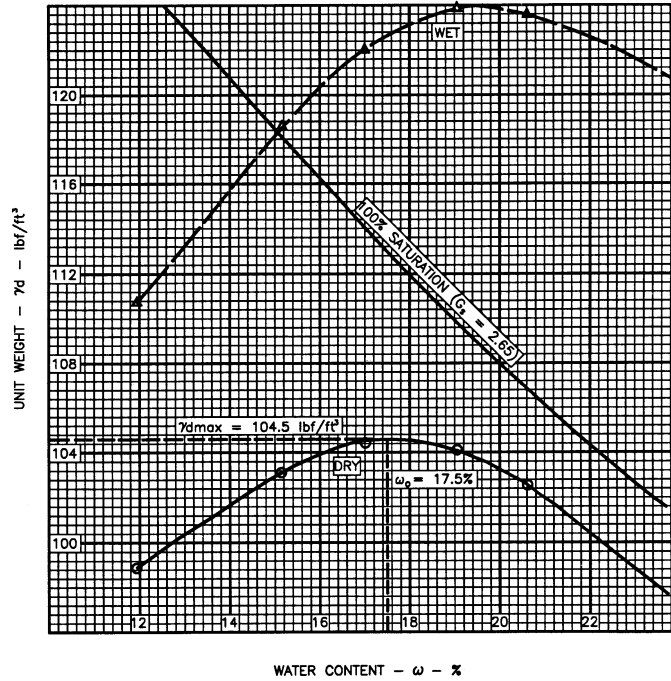

FIG. 3 Example Compaction Curve Plotting

$$\rho_d = \frac{\rho_m}{1 + \frac{w}{100}} \quad (2)$$

where:

ρ_d = dry density of compacted specimen, Mg/m³, and
 w = water content, % .

$$\gamma_d = 62.43 \rho_d \text{ in lbf/ft}^3 \quad (3)$$

or

$$\gamma_d = 9.807 \rho_d \text{ in kN/m}^3 \quad (4)$$

where:

γ_d = dry unit weight of compacted specimen.

11.5 To calculate points for plotting the 100 % saturation curve or zero air voids curve select values of dry unit weight, calculate corresponding values of water content corresponding to the condition of 100 % saturation as follows:

$$w_{\text{sat}} = \frac{(\gamma_w)(G_s) - \gamma_d}{(\gamma_d)(G_s)} \times 100 \quad (5)$$

where:

w_{sat} = water content for complete saturation, %,
 γ_w = unit weight of water, 62.432 lbf/ft³ (9.807 kN/m³) (9.789 kN/m³) at 20°C,
 γ_d = dry unit weight of soil, lbf/ft (kN/m³), and
 G_s = specific gravity of soil.

NOTE 1—Specific gravity may be estimated for the test specimen on the basis of test data from other samples of the same soil classification and source. Otherwise, a specific gravity test (Test Method C 127, Test Method D 854, or both) is necessary.

12. Report: Data Sheet(s)/Form(s)

12.1 The report data sheet(s)/form(s) shall contain the following information:

12.1.1 Procedure

12.1.1 Method used (A, B, or C).

12.1.2 Preparation method used (moist or dry).

12.1.3 As received water content if determined.

12.1.4 Standard optimum water content, to the nearest 0.51 %.

- 12.1.5 Standard maximum dry unit weight, to the nearest 0.1 lbf/ft^3 .
- 12.1.6 Description of rammer (manual or mechanical).
- 12.1.7 Soil sieve data when applicable for determination of procedure Method (A, B, or C) used.
- 12.1.8 Description of material used in test, by Practice D 2488, or classification by Test Method D 2487.
- 12.1.9 Specific gravity and method of determination.
- 12.1.10 Origin of material used in test, for example, project, location, depth, and the like.
- 12.1.11 Compaction curve plot showing compaction points used to establish compaction curve, and 100 % saturation curve, point of maximum dry unit weight and optimum water content.
- 12.1.12 Oversize correction data if used, including the oversize fraction (coarse fraction), P_c in %.

13. Precision and Bias

13.1 *Precision*—Data are being evaluated to determine—Criteria for judging the acceptability of test results obtained by these test methods on a range of soil types are given in Table 3 and Table 4. These estimates of precision are based on the results of the interlaboratory program conducted by the ASTM Reference Soils and Testing Program¹⁰. In this program, Method A and the Dry Preparation Method were used. In addition, some laboratories performed three replicate tests per soil type (triplicate test laboratory), while other laboratories performed a single test per soil type (single test laboratory). A description of the soils tested is given in 13.1.4. The precision estimates vary with soil type, and may vary with methods used (Method A, B, or C, or wet/dry preparation method). Judgement is required when applying these estimates to another soil, method, or preparation method.

13.1.1 The data in Table 3 are based on three replicate test performed by each triplicate test laboratory on each soil type. The single operator and multilaboratory standard deviation show in Table 3, Column 4 were obtained in accordance with Practice E 691, which recommends each testing laboratory perform a minimum of three replicate test. Results of two properly conducted test performed by the same operator on the same material, using the same equipment, and in the shortest practical period of time should not differ by more than the single-operator d_{2s} shown in Table 3, Column 5. For definition of d_{2s} , see Footnote D in Table 1. Results of two properly conducted test performed by different operators and on different days should not differ by more than the multilaboratory d_{2s} limits shown in Table 3, Column 5.

13.1.2 In the ASTM Reference Soils and Testing Program, many of the laboratories performed only a single test on each soil type. This is a common practice in the design and construction industry. The data for each soil type in Table 4 are based upon

¹⁰ Research Report RR:D18-1008 contains the data and statistical analysis used to establish these precision statements and it is available from ASTM Headquarters.

TABLE 3 Summary of Test Results from Triplicate Test Laboratories (Standard Effort Compaction)

(1) Number of Triplicate Test Labs			(2) Test Value ^A (Units)	(3) Average Value ^B			(4) Standard Deviation ^C			(5) Acceptable Range of Two Results ^{D,E}		
<i>Soil Type:</i>												
CH	CL	ML		CH	CL	ML	CH	CL	ML	CH	CL	ML
<i>Single-Operator Results (Within-Laboratory Repeatability):</i>												
11	12	11	$\gamma_{d,max}$ (pcf)	97.2	109.2	106.3	0.5	0.4	0.5	1.3	1.2	1.3
11	12	11	w_{opt} (%)	22.8	16.6	17.1	0.2	0.3	0.3	0.7	0.9	0.9
<i>Multilaboratory Results (Between-Laboratory Reproducibility):</i>												
11	12	11	$\gamma_{d,max}$ (pcf)	97.2	109.2	106.3	1.4	0.8	0.6	3.9	2.3	1.6
11	12	11	w_{opt} (%)	22.8	16.6	17.1	0.7	0.5	0.5	1.8	1.5	1.3

^A $\gamma_{d,max}$ (pcf) = standard maximum dry unit weight in lbf/ft^3 and w_{opt} (%) = standard optimum water in percent.

^B The number of significant digits and decimal places presented are representative of the input data. In accordance with Practice D 6026, the standard deviation and acceptable range of results can not have more decimal places than the input data.

^C Standard deviation is calculated in accordance with Practice E 691 and is referred to as the 1 s limit.

^D Acceptable range of two results is referred to as the d_{2s} limit. It is calculated as $1.960 \sqrt{2} \cdot 1s$, as defined by Practice E 177. The difference between two properly conducted tests should not exceed this limit. The number of significant digits/decimal places presented is equal to that prescribed by this standard or Practice D 6026. In addition, the value presented can have the same number of decimal places as the standard deviation, even if that result has more significant digits than the standard deviation.

^E Both values of $\gamma_{d,max}$ and w_{opt} have to fall within values given for the selected soil type.

TABLE 4 Summary of Single Test Results from Each Laboratories (Standard Effort Compaction)^A

(1) Number of Test Laboratories			(2) Test Value (Units)	(3) Average Value			(4) Standard Deviation			(5) Acceptable Range of Two Results		
<i>Soil Type:</i>												
CH	CL	ML		CH	CL	ML	CH	CL	ML	CH	CL	ML
<i>Multilaboratory Results (Between-Laboratory Reproducibility):</i>												
26	26	25	$\gamma_{d,max}$ (pcf)	97.3	109.2	106.2	1.6	1.1	1.0	4.5	3.0	2.9
			w_{opt} (%)	22.6	16.4	16.7	0.9	0.7	1.0	2.4	1.8	2.9

^A See footnotes in Table 3.

the first test result from the triplicate test laboratories and the single test results from the other laboratories. Results of two properly conducted test performed by two different laboratories with different operators using different equipment and on different days should not vary by more than the d_2s limits shown in Table 4, Column 5. The results in Table 3 and Table 4 are dissimilar because the data sets are different.

13.1.3 Table 3 presents a rigorous interpretation of triplicate test data in accordance with Practice E 691 from pre-qualified laboratories. Table 4 is derived from test data that represents common practice.

13.1.4 *Soil Types*- Based on the multilaboratory test results the soils used in the program are described below in accordance with Practice D 2487. In addition, the local names of the soils are given.

<u>CH</u>	—Fat clay, CH, 99 % fines, LL=60, PI=39, grayish brown, soil had been air dried and pulverized. Local name—Vicksburg Buckshot Clay
<u>CL</u>	—Lean clay, CL, 89 % fines, LL=33, PI=13, gray, soil had been air dried and pulverized. Local name—Annapolis Clay
<u>ML</u>	—Silt, ML, 99 % fines, LL=27, PI=4, light brown, soil had been air dried and pulverized. Local name—Vicksburg Silt

13.2 *Bias*—It—There is not possible to obtain information on bias because there is no other method of determining the accepted reference values of standard maximum dry unit weight and optimum water content for this test method, therefore, bias cannot be determined.

14. Keywords

14.1 ~~NT~~—impact compaction using standard effort; ~~RT~~— density; ~~RT~~— moisture-density curves; ~~RT~~—proctor proctor test; ~~UF~~— compaction characteristics; ~~UF~~—soil soil compaction; ~~USE~~—laboratory laboratory tests

ANNEX

(Mandatory Information)

A1. VOLUME OF COMPACTION MOLD

A1.1 Scope

A1.1.1 This annex describes the procedure for determining the volume of a compaction mold.

A1.1.2 The volume is determined by a water-filled method and checked by a linear-measurement method.

A1.2 Apparatus

A1.2.1 In addition to the apparatus listed in Section 6 the following items are required:

A1.2.1.1 *Vernier or Dial Caliper*—having a measuring range of at least 0 to 6 in. (0 to 150 mm) and readable to at least 0.001 in. (0.02 mm).

A1.2.1.2 *Inside Micrometer*—having a measuring range of at least 2 to 12 in. (50 to 300 mm) and readable to at least 0.001 in. (0.02 mm).

A1.2.1.3 *Plastic or Glass Plates*—Two plastic or glass plates approximately 8 in. square by ¼ in. thick (200 by 200 mm by 6 mm).

A1.2.1.4 *Thermometer*— 0 to 50°C range, 0.5°C graduations, conforming to the requirements of Specification E 1.

A1.2.1.5 *Stopcock grease* or similar sealant.

A1.2.1.6 *Miscellaneous equipment*—Bulb syringe, towels, etc.

A1.3 Precautions

A1.3.1 Perform this procedure method in an area isolated from drafts or extreme temperature fluctuations.

A1.4 Procedure

A1.4.1 Water-Filling Method:

A1.4.1.1 Lightly grease the bottom of the compaction mold and place it on one of the plastic or glass plates. Lightly grease the top of the mold. Be careful not to get grease on the inside of the mold. If it is necessary to use the base plate, as noted in 10.4.7, place the greased mold onto the base plate and secure with the locking studs.

A1.4.1.2 Determine the mass of the greased mold and both plastic or glass plates to the nearest 0.01-lbm (1-g) and record. When the base plate is being used in lieu of the bottom plastic or glass plate determine the mass of the mold, base plate and a single plastic or glass plate to be used on top of the mold to the nearest 0.01-lbm (1-g) and record.

A1.4.1.3 Place the mold and the bottom plastic or glass plate on a firm, level surface and fill the mold with water to slightly above its rim.

A1.4.1.4 Slide the second plate over the top surface of the mold so that the mold remains completely filled with water and air bubbles are not entrapped. Add or remove water as necessary with a bulb syringe.

A1.4.1.5 Completely dry any excess water from the outside of the mold and plates.

A1.4.1.6 Determine the mass of the mold, plates and water and record to the nearest 0.01-lbm (1-g).

A1.4.1.7 Determine the temperature of the water in the mold to the nearest 1°C and record. Determine and record the absolute density of water from Table A1.1.

A1.4.1.8 Calculate the mass of water in the mold by subtracting the mass determined in A1.4.1.2 from the mass determined in A1.4.1.6.

A1.4.1.9 Calculate the volume of water by dividing the mass of water by the density of water and record to the nearest 0.0001 ft³ (1 cm³).

A1.4.1.10 When the base plate is used for the calibration of the mold volume repeat A1.4.1.3-A1.4.1.9.

A1.4.2 Linear Measurement Method :

A1.4.2.1 Using either the vernier caliper or the inside micrometer, measure the diameter of the mold 6 times at the top of the mold and 6 times at the bottom of the mold, spacing each of the six top and bottom measurements equally around the circumference of the mold. Record the values to the nearest 0.001-in. (0.02-mm).

A1.4.2.2 Using the vernier caliper, measure the inside height of the mold by making three measurements equally spaced around the circumference of the mold. Record values to the nearest 0.001-in. (0.02-mm).

A1.4.2.3 Calculate the average top diameter, average bottom diameter and average height.

A1.4.2.4 Calculate the volume of the mold and record to the nearest 0.0001 ft³ (1 cm³) as follows:

$$V = \frac{(\pi)(h)(d_t + d_b)^2}{(16)(1728)} \text{ (inch-pound)} \quad (\text{A1.1})$$

$$V = \frac{(\pi)(h)(d_t + d_b)^2}{(16)(103)} (SI) \quad (\text{A1.2})$$

$$V = \frac{(\pi)(h)(d_t + d_b)^2}{(16)(1000)} (SI) \quad (\text{A1.2})$$

TABLE A1.1 Density of Water^A

Temperature, °C (°F)	Density of Water, g/mL or g/cm ³
18 (64.4)	0.99862
18 (64.4)	0.99860
19 (66.2)	0.99843
19 (66.2)	0.99841
20 (68.0)	0.99823
20 (68.0)	0.99821
24 (69.8)	0.99802
21 (69.8)	0.99799
22 (71.6)	0.99779
22 (71.6)	0.99777
23 (73.4)	0.99756
23 (73.4)	0.99754
24 (75.2)	0.99733
24 (75.2)	0.99730
25 (77.0)	0.99707
25 (77.0)	0.99705
26 (78.8)	0.99684
26 (78.8)	0.99679

^AValues other than shown may be obtained (5).

where:

- V = volume of mold, ft^3 (cm^3),
- h = average height, in. (mm),
- d_t = average top diameter, in. (mm),
- d_b = average bottom diameter, in. (mm),
- $^{1/1728}$ = constant to convert in^3 to ft^3 , and
- $3^{-1/1000}$ constant to convert mm^3 to cm^3 .

A1.5 Comparison of Results

- A1.5.1 The volume obtained by either method should be within the volume tolerance requirements of 6.1.1 and 6.1.2.
- A1.5.2 The difference between the two methods should not exceed 0.5 % of the nominal volume of the mold.
- A1.5.3 Repeat the determination of volume if these criteria are not met.
- A1.5.4 Failure to obtain satisfactory agreement between the two methods, even after several trials, is an indication that the mold is badly deformed and should be replaced.
- A1.5.5 Use the volume of the mold determined using the water-filling method as the assigned volume value for calculating the moist and dry density (see 11.4).

REFERENCES

- (1) *Earth Manual*, United States Bureau of Reclamation, Part 1, Third Edition, 1998, pp. 255-260.
- (2) *Earth Manual*, United States Bureau of Reclamation, Part 2, Third Edition, 1990, USBR 5515
- (3) Torrey, V.H., and Donaghe, R.T., "Compaction Control of Earth-Rock Mixtures: A New Approach," *Geotechnical Testing Journal*, GTJODJ, Vol 17, No. 3, September 1994, pp. 371-386.
- (4) Johnson, A.W., and Sallberg, J.R., *Factors Influencing Compaction Test Results*, Highway Research Board, Bulletin 318, Publication 967, National Academy of Sciences-National Research Council, Washington, DC, 1962, p. 73.
- (5) *CRC Handbook of Chemistry and Physics*, Chemical Rubber Publishing Co., Cleveland, OH, David R. Lide, Editor-in-Chief, 74th Edition, 1993-1994.

SUMMARY OF CHANGES

In accordance with Committee D18 policy, this section identifies the location of changes to this standard since the last published edition (1991(Reapproved 1998)) that may impact the use of this standard.

Changes made in the March 2000 revision.

- (1) Changed "Method" to "Methods" in the title to indicate there is more than one method to perform this test method. The Summary of Changes section was added.
- (2) In 1.6.1, replaced reference "Method" to Practice E 380 "Methods in the title to reflect multiple methods. Replace "Procedure A, B, or C" with IEEE/ASTM SI 10: "Method A, B, or C", and "procedure(s) with "methods(s)", where applicable. Replaced the terms "by weight" with "by mass", where applicable.
- (3) In Section 2, 1.6.1, replaced E 380 with IEEE/ASTM SI 10, and added D 4914 and D 5030: 10.
- (4) In Section 2, replaced E 380 with IEEE/ASTM SI 10 and added D 4914 and D 5030.
- (5) In the Significance and Use section, added subsection, added subsections 5.3-5.3.3 along with two references. These subsections discussing the problems in applying Test Method D 698 Methods D 1557 when dealing with soils containing oversize fractions, in which degradation occurs, and soils which are gap graded.
- (6) In Table A1.1, the density values were updated to agree with Test Methods D 854 and in 11.5 unit weight of water values were updated to agree with the density values in Test Methods D 854 at 20°C.

Changes made in the June 2000 revision.

- (1) Under Referenced Documents, added Practices D 3740, D 6026, E 177, and E 691.
- (2) Following the Significance and Use section, a note was added referencing Practice D 3740 in accordance with the policy of D18. Renumbered the remaining notes.
- (3) In 12, changed title and 12.1 to state that this section covers what data needs to be recorded on the data sheets(s)/form(s). In addition, the recording sensitivity for the optimum water content and maximum dry weight was changed from 0.5 to 0.1
- (4) The precision statement in 13.1 was completely revised, and now includes data.
- (5) The bias statement was reworded.

ASTM International takes no position respecting the validity of any patent rights asserted in connection with any item mentioned in this standard. Users of this standard are expressly advised that determination of the validity of any such patent rights, and the risk of infringement of such rights, are entirely their own responsibility.

This standard is subject to revision at any time by the responsible technical committee and must be reviewed every five years and if not revised, either reapproved or withdrawn. Your comments are invited either for revision of this standard or for additional standards and should be addressed to ASTM International Headquarters. Your comments will receive careful consideration at a meeting of the responsible technical committee, which you may attend. If you feel that your comments have not received a fair hearing you should make your views known to the ASTM Committee on Standards, at the address shown below.

This standard is copyrighted by ASTM International, 100 Barr Harbor Drive, PO Box C700, West Conshohocken, PA 19428-2959, United States. Individual reprints (single or multiple copies) of this standard may be obtained by contacting ASTM at the above address or at 610-832-9585 (phone), 610-832-9555 (fax), or service@astm.org (e-mail); or through the ASTM website (www.astm.org).