



Standard Practice for Using Hollow-Stem Augers for Geotechnical Exploration and Soil Sampling¹

This standard is issued under the fixed designation D 6151; the number immediately following the designation indicates the year of original adoption or, in the case of revision, the year of last revision. A number in parentheses indicates the year of last reapproval. A superscript epsilon (ϵ) indicates an editorial change since the last revision or reapproval.

1. Scope

1.1 This practice covers how to obtain soil samples using hollow-stem sampling systems and use of hollow-stem auger drilling methods for geotechnical exploration. This practice addresses how to obtain soil samples suitable for engineering properties testing.

1.2 In most geotechnical explorations, hollow-stem auger drilling is combined with other sampling methods. Split barrel penetration tests (Test Method D 1586) are often performed to provide estimates of engineering properties of soils. Thin-wall tube (Practice D 1587) and ring-lined barrel samples (Practice D 3550) are also frequently taken. This practice discusses hole preparation for these sampling events. For information on the sampling process, consult the related standards. Other in situ tests, such as the vane shear Test Method D 2573, can be performed below the base of the boring by access through the drill string.

1.3 This practice does not include considerations for geoenvironmental site characterizations and installation of monitoring wells which are addressed in Guide D 5784.

1.4 This practice may not reflect all aspects of operations. It offers guidance on current practice but does not recommend a specific course of action. It should not be used as the sole criterion or basis of comparison, and does not replace or relieve professional judgment.

1.5 *Hollow-stem auger drilling for geotechnical exploration often involves safety planning, administration, and documentation. This standard does not purport to specifically address exploration and site safety. It is the responsibility of the user of this standard to establish appropriate safety and health practices and determine the applicability of regulatory limitations prior to its use.* Performance of the test usually involves use of a drill rig, therefore, safety requirements as outlined in applicable safety standards, for example OSHA (Occupational Health and Safety Administration) regulations, DCDMA safety manual (1),² drilling safety manuals, and other applicable state and local regulations must be observed.

¹ This practice is under the jurisdiction of ASTM Committee D18 on Soil and Rock and is the direct responsibility of Subcommittee D18.02 on Sampling and Related Field Testing for Soil Investigations.

Current edition approved August 10, 1997, Published December 1997.

² The boldface numbers in parentheses refer to the references at the end of this practice.

2. Referenced Documents

2.1 ASTM Standards:

D 420 Guide to Site Characterization for Engineering, Design, and Construction Purposes³

D 653 Terminology Relating to Soil, Rock, and Contained Fluids³

D 2488 Practice for Description and Identification of Soils (Visual-Manual Procedure)³

D 5434 Guide for Field Logging of Subsurface Explorations of Soil and Rock³

2.2 Standards for Sampling of Soil and Rock:

D 1452 Practice for Soil Investigation and Sampling by Auger Borings³

D 1586 Test Method for Penetration Test and Split-Barrel Sampling of Soils³

D 1587 Practice for Thin-Walled Tube Geotechnical Sampling of Soils³

D 2113 Practice for Diamond Core Drilling for Site Investigation³

D 3550 Practice for Ring-Lined Barrel Sampling of Soils³

D 4220 Practice for Preserving and Transporting Soil Samples³

D 4700 Guide for Soil Sampling from the Vadose Zone³

D 5079 Practices for Preserving and Transporting Rock Core Samples³

2.3 In situ Testing:

D 2573 Test Method for Field Vane Shear Test in Cohesive Soils³

D 3441 Test Method for Deep, Quasi Static, Cone and Friction-Cone Penetration Tests of Soil³

D 4719 Test Method for Pressuremeter Testing in Soils³

2.4 Instrument Installation and Monitoring:

D 4428 Test Methods for Crosshole Seismic Testing³

D 4750 Test Method for Determining Subsurface Liquid Levels in a Borehole or Monitoring Well (Observation Well)³

D 5092 Practice for Design and Installation of Ground Water Monitoring Wells in Aquifers³

2.5 Drilling Methods:

D 5784 Guide for the Use of Hollow-Stem Augers for

³ Annual Book of ASTM Standards, Vol 04.08.

Geoenvironmental Exploration and the Installation of Subsurface Water-Quality Monitoring Devices⁴

D 5876 Guide for the Use of Direct Rotary Wireline Casing Advancement Drilling Methods for Geoenvironmental Exploration and the Installation of Subsurface Water-Quality Monitoring Devices⁴

3. Terminology

3.1 *Definitions:* Terminology used within this practice is in accordance with Terminology D 653 with the addition of the following (see Figs. 1-5 for typical system components):

3.1.1 *auger cutter head*—the terminal section of the lead auger equipped with a hollow cutting head for cutting soil. The cutter head is connected to the lead auger. The cutter head is equipped with abrasion-resistant cutting devices, normally with carbide surfaces. The cutter can be teeth (usually square or conical), or blades (rectangular or spade design). Cutter head designs may utilize one style cutter or a combination of cutters.

3.1.2 *bit clearance ratio*—a ratio, expressed as a percentage of the difference between the inside diameter of the sampling

⁴ Annual Book of ASTM Standards, Vol 04.09.

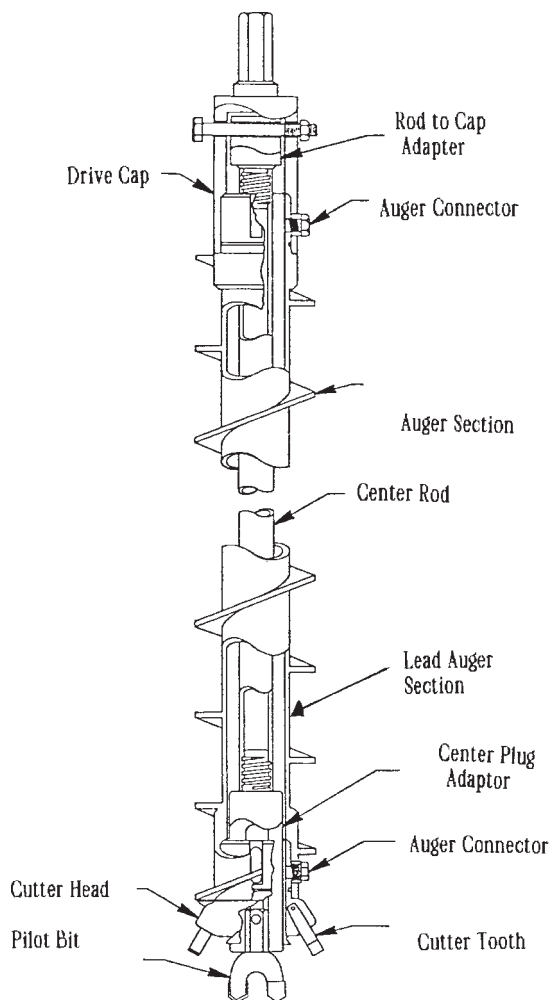

FIG. 1 Rod-Type Auger System With Pilot Bit⁶

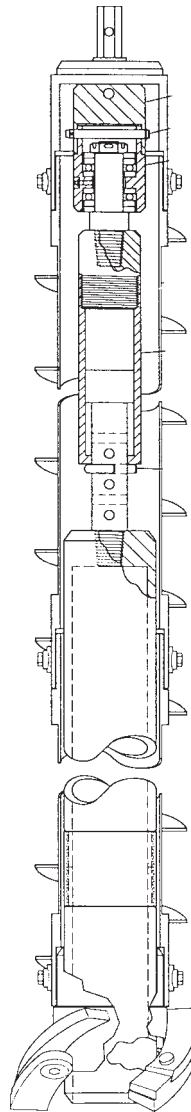

FIG. 2 Example of Rod-Type Sampling System⁵

tube and the inside diameter of the cutting bit divided by the inside diameter of the sampling tube.

3.1.3 *blow-in*—(Practice D 5092)—the inflow of groundwater and unconsolidated material into the borehole or casing caused by differential hydraulic heads; that is, caused by the presence of a greater hydraulic head outside the borehole/casing than inside. Also known as *sanding in* or *soil heave*.

3.1.4 *clean out depth*—the depth to which the end of the drill string (bit or core barrel cutting end) has reached after an interval of drilling. The clean out depth (or drilled depth as it is referred to after cleaning out of any sloughed material or cuttings in the bottom of the drill hole) is normally recorded to the nearest 0.1 ft. (0.03 m).

3.1.5 *continuous sampling devices*—sampling systems which continuously sample as the drilling progresses. Hollow-stem sampling systems are often referred to as continuous samplers because they can be operated in that mode. Hollow-stem sampling systems are double-tube augers where barrel-type samplers fit within the lead auger of the hollow auger column. The double-tube auger operates as a soil coring system

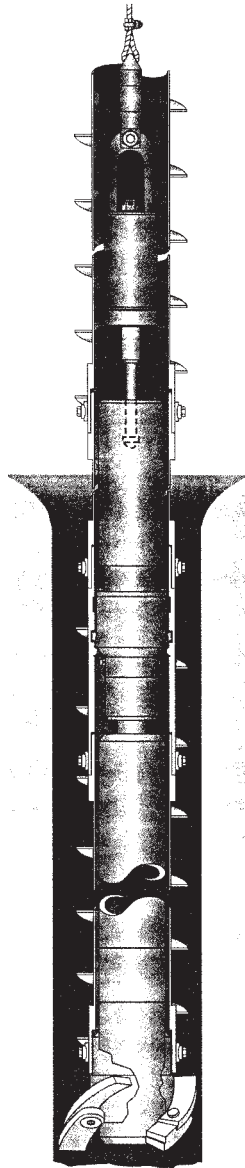

FIG. 3 Example of Wireline Sampling System⁵

in certain subsurface conditions where the sampler barrel fills with material as the augers advance. The barrel can be removed and replaced during pauses in drilling for continuous coring.

3.1.6 *double-tube auger*—an auger equipped with an inner barrel for soil sampling (soil coring). If equipped with an inner barrel and liner, the auger system can be described as a triple-tube auger.

3.1.7 *drill hole*—a cylindrical hole advanced into the subsurface by mechanical means. Also known as borehole or boring.

3.1.8 *drill string*—the complete drilling assembly under rotation including augers, core barrel or pilot bit, drill rods, and connector subassemblies. Drilling depth is determined by

knowledge of the total length of the drill string, and by subtracting the string length above a ground surface datum.

3.1.9 *fluid injection devices*—pumps, fittings, hose and pipe components, or drill rig attachments that may be used to inject a fluid within a hollow auger column during drilling.

3.1.10 *HSA*—Hollow stem auger(s). See 3.1.11.

3.1.11 *hollow stem auger*—a cylindrical hollow tube with a continuous helical fluting/flighting on the outside, which acts as a screw conveyor to lift cuttings produced by an auger drill head or cutter head bit to the surface.

3.1.12 *in-hole-hammer*—a drop hammer for driving a soil sampling device. The in-hole hammer is designed to run down-hole within the HSA column. It is usually operated with

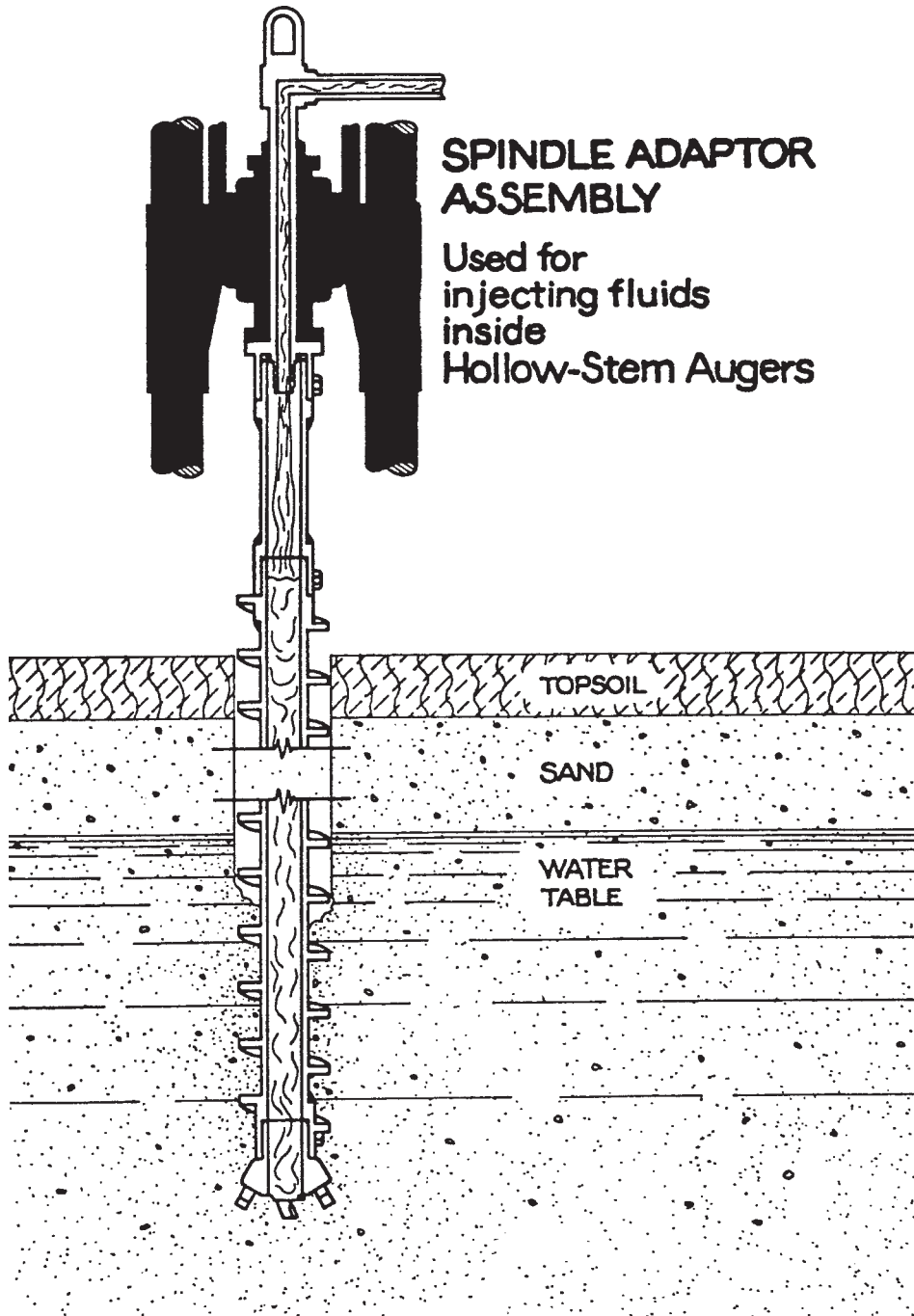

FIG. 4 Spindle Adaptor Assembly

a free-fall wireline hoist capable of lifting and dropping the hammer weight to drive the sampler below the HSA column and retrieve the hammer and sampler to the surface. See Fig. 6⁵

3.1.13 *in situ testing devices*—sensors or probes, used for obtaining test data for estimation of engineering properties, that are typically pushed, rotated, or driven in advance of the hollow auger column assembly at a designated depth or advanced simultaneously with advancement of the auger column (see 2.3).

3.1.14 *intermittent sampling devices*—barrel-type samplers that may be rotated, driven, or pushed below the auger head at a designated depth prior to advancement of the auger column (see 2.2).

3.1.15 *lead auger assembly*—the first hollow stem auger to be advanced into the subsurface. The end of the lead auger assembly is equipped with a cutter head for cutting. The lead auger may also contain a pilot bit assembly or sample barrel assembly housed within the hollow portion of the auger. If a wireline system is used, the lead auger assembly will have an adapter housing on top of the first auger containing a latching

⁵ Foremost Mobile, Mobile Drilling Company Inc., 3807 Madison Avenue, Indianapolis, IN.

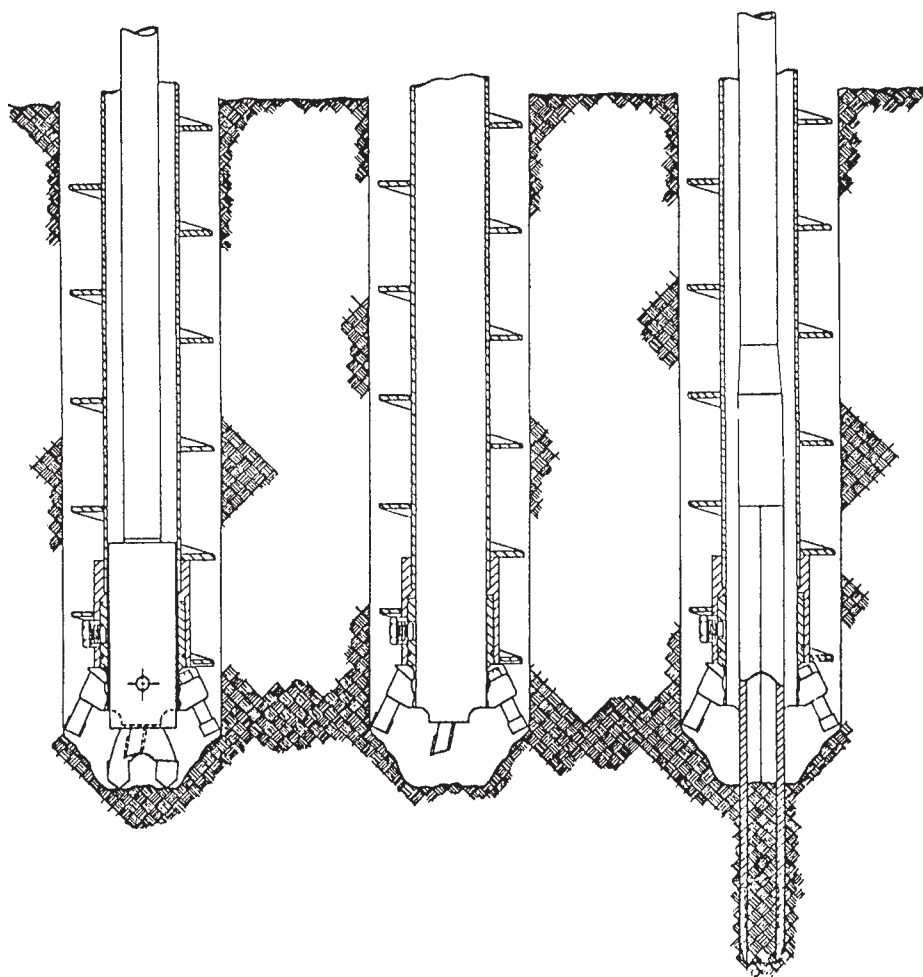

FIG. 5 Example of Drive Case Sampling Through HSA

device for locking the pilot bit assembly or sampling core barrel into the lead auger assembly.

3.1.16 *lead distance*—the mechanically adjusted length or distance that the inner core barrel cutting shoe is set to extend beyond the lead auger assembly cutting head.

3.1.17 *overshot*—a latching mechanism located at the end of the hoisting line (wireline). It is specially designed to latch onto or release the pilot bit or core barrel assemblies. It serves as a lifting device for removing the pilot bit or sampler assembly.

3.1.18 *O-ring*—a rubber ring for preventing leakage between joining metal connections, such as hollow-stem auger sections.

3.1.19 *percent recovery*—percentage which indicates the success of sample retrieval, calculated by dividing the length of sample recovered by the length of sampler advancement.

3.1.20 *pilot bit assembly*—an assembly designed to attach to a drill rod or lock into the lead auger assembly for drilling without sampling. The pilot bit can have various configurations (drag bit, roller cone, tooth bit, or combination of designs) to aid in more efficient or rapid hole advancement.

3.1.21 *recovery length*—the length of sample actually retrieved during the sampling operation.

3.1.22 *sanding in*—a condition that occurs when sand or silt enters the auger after removal of the pilot bit or sampling

barrel. See *blow-in*. Sanding in can occur from hydrostatic imbalance or by suction forces caused by removal of the pilot bit or sampling barrel.

3.1.23 *slough*—the disturbed material left in the bottom of the borehole, usually from falling off the side of the borehole, or falling out of the sampler, or off of the auger.

3.1.24 *soil coring, hollow-stem*—The drilling process of using a double-tube HSA system to intermittently or continuously sample the subsurface material (soil).

3.1.25 *wireline drilling, hollow-stem*—a rotary drilling process using a lead auger which holds a pilot bit or sampling barrel delivered and removed by wireline hoisting. Latching assemblies are used to lock or unlock the pilot bit or sampler barrel. The pilot bit or core barrel is raised or lowered on a wireline cable with an overshot latching device.

4. Significance and Use

4.1 Hollow-stem augers are frequently used for geotechnical exploration. Often, hollow-stem augers are used with other sampling systems, such as split barrel penetration resistance testing, Test Method D 1586, or thin-wall tube sampling, Practice D 1587 (see 2.5). Hollow-stem augers may be used to advance a drill hole without sampling using a pilot bit assembly, or they may be equipped with a sampling system for obtaining soil cores. In some subsurface conditions that contain

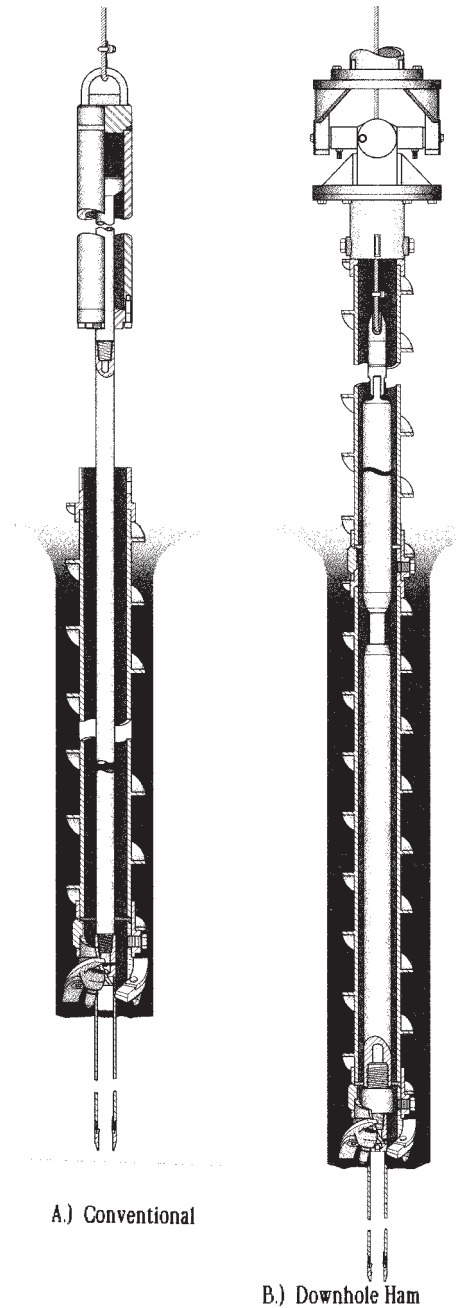

FIG. 6 In-Hole-Hammer and Conventional Drive Hammer⁵

cohesive soils, the drillhole can be successfully advanced without the use of a pilot bit assembly. Intermittent drilling (advancing of the HSA column with or without a pilot bit) and sampling can be performed depending on the intervals to be sampled, or continuous sampling can be performed. During pauses in the drilling and sampling process, in situ testing or other soil sampling methods can be performed through the hollow auger column below the lead auger assembly. At completion of the boring to the depth of interest, the hole may be abandoned or testing or monitoring devices can be installed. Hollow-stem auger drilling allows for drilling and casing the hole simultaneously, thereby eliminating hole caving problems and contamination of soil samples (2). The hollow-stem auger

drilling and sampling method can be a satisfactory means for collecting samples of shallow unconsolidated subsurface materials (2). Additional guidance on use can be found in Refs. 2, 3, 4, 5, 6.

4.2 Soil sampling with a double-tube hollow-stem sampling system provides a method for obtaining continuous or intermittent samples of soils for accurate logging of subsurface materials to support geotechnical testing and exploration. A wide variety of soils from clays to sands can be sampled. The sampling systems can be particularly effective in dry soft to stiff clayey or silty deposits but also can work well under saturated conditions. Saturated cohesionless soils such as clean sands may flow and cave during drilling (see Note 1). In many

cases, the HSA soil core sampling system can produce very little disturbance to the sample and can provide samples for laboratory tests for measurement of selected engineering properties. Large-diameter soil cores, if taken carefully, can provide Class C and D samples as described in Practice D 4220. The HSA systems can also provide disturbed samples of unsaturated sands and gravels with some structure preserved. Full 5-ft (1.5-m) long cores usually cannot be obtained in unsaturated sands due to increasing side wall friction between the dry sands and inside surface of the sample core barrel. Sample length of 2 to 2.5 ft. (0.60 to 0.75 m) is generally the limit of amount of sample that can be recovered in unsaturated sands before the friction between the sampler and the sand becomes too high and causes blocking or plugging of the sampler. Shorter large diameter core runs of 2.5 ft with the 5-ft sample barrel system, or with a 2.5-ft sample barrel system, have generally proven to result in the best samples.

NOTE 1—Research on thin-wall piston sampling in clean sands indicates that in general it is impossible to obtain truly undisturbed samples of saturated clean sands. These soils can dilate or collapse upon insertion of a sampling tube. The hollow-stem auger double-tube system can only obtain partially disturbed samples of sands below the water table.

4.3 Hollow-stem auger drilling is considered a shallow drilling method with maximum depth of drilling of 200 to 300 ft (60 to 90 m) depending on torque and pull down/retract capacity of the drilling equipment and subsurface conditions of the formation(s) encountered. Saturated loose unconsolidated deposits further limit maximum depth that can be attained. Hollow-stem augers can act as casings set through unconsolidated surficial soils and drilling can be converted to other methods (see 2.5) for deeper drilling.

4.4 Drilling and soil sampling can be accomplished with a variety of hollow-stem auger systems. Types of systems can be chosen depending on the advantages of handling, sampling requirements, and subsurface conditions. There are two basic types of systems. One type of system uses inner drill rods or hex rods connecting the sampler or pilot bit assembly to the surface for advancing and retrieving the sampler barrel or pilot bit assembly (Fig. 1⁶ and Fig. 2⁵). Another system uses a wireline latching system in the HSA column to lower, latch, and retrieve a core barrel or pilot bit assembly (Fig. 3⁵).

4.5 Double tube hollow-stem auger sampling systems can be particularly advantageous for sampling water-sensitive soils, such as collapsible soils, since fluid is not used in the drilling process. Since no pressurized circulation medium is used during the drilling process, the possibility for hydraulic fracturing of formation materials and core contamination from drill fluids is reduced.

4.6 Difficulties in drilling may occur if cohesionless soils are drilled below the water table. Possibilities for sand lock or wedging of cuttings may occur (2). In cases where sands enter the HSA, water or drilling fluid may be added to the HSA column to provide hydrostatic balance or special pilot bit assemblies can be used (see 5.6). Problems may occur in getting the soil core barrel or pilot bit assembly back to the

bottom of the HSA column. Highly saturated sands or liquefiable material may be drawn into the HSA by vacuum created when the sampler barrel or pilot bit assembly is initially pulled back through the cutter head of the lead auger assembly from the bottom of the borehole.

4.7 Consideration should be given to proper decontamination and cleaning of drilling equipment, hollow-stem augers, samplers, and soil coring components.

5. Apparatus

5.1 Fig. 1 illustrates the components of a hollow-stem auger used with a pilot bit for hole advancement using a center-inner rod system. Figs. 2 and 3 illustrate hollow-stem augers equipped for soil sampling in either a rod-type or wireline system. Hollow-stem auger systems consist of rotating outer hollow-stem augers and a cutter head assembly, with either a center pilot bit or a nonrotating inner sample barrel with a smooth cutting shoe.

5.2 *Hollow-stem Augers*—Each auger section of the hollow-stem auger assembly consists of a cylindrical steel tube with continuous helical steel flights rigidly attached to the outer surface of the tube (see Fig. 1). Each hollow auger section has a coupling at each end for attaching additional auger sections at the top end to make up the articulated hollow-stem auger column. The bottom of the lead auger has a coupling attachment for the cutter head. Typical hollow-stem auger inside diameters are 2¹/₄, 3¹/₄, 3³/₈, 4¹/₄, 4⁵/₈, 6¹/₄, 6⁵/₈, and range up to 12¹/₄ in. (57, 83, 86, 108, 117, 159, 168, and 311 mm). Outside diameters of the auger flights range from 5 to 18 in. (127 to 457 mm). Typical HSA double-tube sample inside diameters range from 2.25 to 6.85 (57 to 174 mm). Hollow-stem augers are normally supplied in 5-ft (1.5-m) lengths. The helical auger flights are often hard surfaced for better wearing characteristics.

5.2.1 *Diameter Requirements*—The inside diameter of the hollow-stem auger system is selected by considering sample size requirements, intermittent sampling and in situ testing tool size, and completion requirements. For undisturbed sampling, larger-diameter systems generally produce less disturbance (6). For logging purposes, where a disturbed sample is sufficient, smaller diameters are selected. The inside diameter of the hollow stem must be large enough to insert intermittent sampling or in situ testing devices if used (sec 2.2 and 2.3). When using sampling methods such as split barrel, Method D 1586, or thin-wall tube Test Method D 1587, the inside diameter of the hollow-stem should be at least 0.25 in. (6 mm) larger than the sampler outside diameter or rod diameter, which ever is largest. If other drilling methods (see 2.5) are to be used, the inside diameter of the HSA drill string should be selected to accommodate those tools. If special completion is required, such as piezometer or well casing installation, the diameter should be large enough for placing completion materials. For example, if a 2-in. (50 mm) riser pipe is to be completed for shear wave velocity testing in accordance with Test Methods D 4428, consideration of clearance for tremie pipes may also increase diameter requirements. If the lead auger section contains a stabilizer ring, this clearance may govern available diameter for sampling, testing, or completion (see 5.4.1).

⁶ Modified from Central Mine Equipment Company, 4215 Rider Trail North, Earth City, MO.

5.2.2 Auger Connections—Augers are connected using either locking bolts, drive pins, locking collars, or threaded connections. In some cases when drilling saturated soils, water entering the augers may cause difficulty with drilling or sampling. Hollow-stem augers may be used with O-ring seals or other sealing designs at the HSA connections to prevent leakage. Some HSA connection designs have compression seals and bolt caps to facilitate sealing between auger connections. This can prevent soil or water ingress through the auger connecting joints (in certain drilling conditions) and the accumulation of a high solids slurry in the bottom of the HSA column that may interfere with the latching system for retrieval and placement of sample barrel assembly by means of the wireline/overshot system

5.3 Drive Cap—The drive cap assembly (see Fig. 1) attaches to the uppermost hollow-stem auger section and transfers rotary power and axial force from the drill rig to the auger drill string assembly.

5.4 Lead Auger Section—The lead auger has a hollow cutter head. The cutter head is attached to the lead auger of the hollow auger column and usually contains replaceable, abrasion-resistant cutters or teeth (see Fig. 1). As the hollow auger head is rotated, it cuts and directs the cuttings to the auger flights which convey the cuttings to the surface. The cutters can be made of hardened steel or carbide and in several designs. Cutter head types should be selected to effectively remove cuttings and minimize soil disturbance when sampling. The cutter head or cutter teeth, or both, should be replaced if worn or damaged.

5.4.1 If a wireline system is used, there can be an adapter coupling on top of the lead auger and may contain inside barrel grooves or recesses for latching systems for wireline tooling.

5.4.2 A stabilizer ring may be used (usually made of brass) in the end of the HSA cutter head opening. The stabilizer ring is machined to a close tolerance to be slightly larger than the outside diameter of the sample barrel or pilot bit. The actual opening of the end of the HSA column at the cutter head is smaller with this stabilizer ring than the normal designated inside diameter of the HSA being used. The stabilizer ring keeps the sample barrel centered in the middle of the HSA cutter head and prevents material that may interfere with the sample barrel remaining stationary from lodging around the barrel and shoe and between the full opening of the HSA cutter head. In some cases, in unstable soils the vacuum created during removal of the pilot bit through a stabilizer ring may produce sanding in. In these cases, provisions for venting may be required.

5.5 Sampler or bit retrieval system:

5.5.1 Rod-type System (Fig. 1 and Fig. 2)—The sampler or pilot bit can be inserted into the lead auger using a system of inner rods. The inner rods are typically AW, or NW size (7) or hex rods. Rods are supplied in the same lengths as the hollow-stem augers.

5.5.2 Wireline system, In-hole-hammer—The sampler or pilot bit can be inserted into the lead auger by using a free-fall wireline cable hoist capable of lifting and dropping the hammer weight down the hole within the HSA column to drive the sampler below the HSA column. This wireline method can also

be used in conjunction with a drilling rig with an open spindle rotary head to allow the wireline and in-hole-hammer with the proper bit to act as a pilot bit assembly while advancing the HSA column. The weight of the hammer and pilot bit is allowed to float within the HSA column and advance with the cutter head and lead auger section to deter material from entering the HSA column.

5.5.3 Wireline System, Double-tube HSA (Fig. 3)—The sampler or pilot bit is raised and lowered using a wireline and latching mechanism. A wireline system may consist of a latching lead auger section, a locking or latching head assembly above the sample barrel or pilot bit, and an overshot (retrieving tool) that locks into the locking head assembly to hoist and lower the sample barrel or pilot bit assembly through the HSA column.

5.6 Pilot Bit Assembly—The pilot bit assembly can be a machined plug with a bit attached to the bottom to enhance cutting when used with the cutter head of the HSA and to keep material from entering the hollow-stem auger. Another version is a center auger with left-handed fighting to provide a downward spiral rotation in the middle of the HSA drill string. This left hand fighting keeps material from entering the HSA drill string forcing the parent material down and to the outside of the main auger. While the HSA drill string is rotating and drilling, the material displaced by the left hand fighting is conveying up along the outer fighting away from the cutter head to the surface.

5.7 Hollow-stem Double-tube Auger Sample Barrel Systems—The sampler is suspended in the HSA column and is retained in a stationary position. The head may be made with connections to a latching assembly including a bearing assembly. A bearing assembly helps prevent rotation of the sampler barrel and is especially important for undisturbed sampling. In the wireline system the barrel is connected to a latching and hanger bearing assembly that locks into the HSA column (Fig. 3). In the rod-type system (Fig. 2) the bearing is located either down hole or at the top of the auger column and is connected to drill rods or hex rods extending to the top of the HSA column. The drill rod or hex rod string is connected through the auger drive adapter to the drill rig to provide a means of controlling rotation of the sampler.

5.7.1 The sample barrel may be of various sizes and lengths. The barrel may be used with or without liners. A split barrel without a liner is most often used for easy examination of disturbed soil cores while a barrel with a liner is most often used for preserving specimens for laboratory testing. The liners fit in the inside of the barrel to facilitate sample collection. The sample barrel and HSA are matched with respect to size. The actual sample diameter varies with different manufacturers. The sample diameter is controlled by the inside diameter of the cutting shoe. With some manufacturer's designs, the inside diameter of the cutting shoe varies depending upon the liners used in the sample barrel. To obtain samples with minimal disturbance, care must be taken to ensure a smooth transition from the insider diameter of the cutting shoe to the barrel or liners. There should be no gaps or upset surfaces in the inside clearance. A smaller inside diameter shoe can be used when coring swelling materials, such as stiff clays, to allow for the

sample to swell inside the barrel without blocking. Core swelling may affect engineering properties determinations.

5.7.2 Sample barrels may be 5-ft (1.5-m) long, solid or split, 5-ft long one piece, or two 30-in. (0.75-m) barrels (solid or split), with a coupling to make a 5-ft barrel. The 5-ft barrel length matches the length of the lead HSA section. The shorter 2.5-ft (0.75-m) barrel may be used in place of the 5-ft barrel for shorter sampling runs to reduce disturbance and to facilitate handling.

5.7.3 *Retainers*—Basket retainers are used, if necessary, to prevent the sample from falling out of the barrel during retrieval. They are generally used when sampling some wet clays and wet or dry sands and gravels. The retainers may affect the sample quality.

5.7.4 *Cutting Shoe and Lead Distance*—The sample barrel with cutting shoe is extended beyond the cutter head in varying increments. The shoe is set at or beyond the bottom of the cutter bits, or teeth. The extent of the distance the shoe is set beyond the cutter head is dictated by the stiffness of the material to be sampled (cored). When the sampler cutting shoe is extended beyond the cutter head, the cutting edge of the shoe is being forced down in front of the cutter head before the HSA cutter head cuts the soil away. The HSA column and cutter head is rotating around the double-tube HSA soil coring barrel as the drill rig applies down force and rotation to the HSA soil coring column. The softer the material, the greater the lead distance. The harder the soil, the shorter the lead distance. Adjusting the lead distance for the sample barrel shoe may be done by various methods. Some systems require adjusting the lead distance directly above the sample barrel assembly, some can be adjusted at the top of the HSA column. Examples of adjusting methods include the following: rod subs, adjustable hex extension with U-pins, threaded adjustment with locking nut, special HSA drive adapter with adjusting slots, or different shoe lengths. The length of extension may vary from the shoe being flush (even) with the cutter bits to as much as 6 in. (150 mm) or more.

5.7.5 *Liners*—The sample barrel may be fitted with liners. Liners are nominally one 5-ft (1.5-m) length or two 2½-ft (0.75-m) sections. The liners can be metal, stainless steel, or acrylic. Acrylic tubing provides for visual inspection of the material sampled. Clear liners can sometimes show detailed soil layering, but, in many cases, the core could be smeared or masked by the disturbance. If the purpose of the exploration program is detailed, logging the complete core should be inspected. Liners should be checked for roundness and wall thickness. Acrylic tubing is reusable but should be checked for cracks before reuse.

5.8 Auxiliary components of a HSA system are various devices such as auger connector wrenches, auger forks, hoisting hooks, hoisting assemblies, pipe vices, strap wrenches or chain wrenches, and fluid injection swivels or adapters (Fig. 4).

5.9 A drill rig is used to rotate and advance the auger column. The drill rig must be capable of producing controlled rotation, feed pressure, and feed rate. The drill rig should be capable of applying sufficient power and torque at a rotary velocity of 50 to 100 r/min. The drill rig should have a feed stroke of at least the effective length of the auger sections plus

the effective length of the auger couplings plus about 4 in. (100 mm). As the HSA soil coring systems diameters increase, more torque and pull-down/retract capacities of the drill rig will be required. The subsurface conditions to be explored will also affect the torque and pull-down/retract capabilities required of the drill rig. Conditions such as depth to ground water, cemented or very dense formations, loose sands and gravels, cobbles, cohesiveness of soil, and potential for saturated flowing conditions and heaving sands will affect the depth that can be explored with a drill of any given torque and pull-down/retract capability.

6. Drilling and Sampling Procedures

6.1 *General*—Several drilling approaches are discussed in the following sections. Hollow-stem auger drilling can be performed with a pilot bit to advance a boring. During pauses in drilling, sampling and field testing can be performed at the base of the augers. A section is also devoted to taking continuous or intermittent cores with the double tube auger soil coring method. Any combination of these drilling and sampling methods may be performed in a single boring.

6.2 *General Drilling and Sampling Considerations:*

6.2.1 *Site Setup*—Stabilize the drill rig, erect the drill rig mast, and attach an initial assembly of hollow-stem auger components (Fig. 1) to the rotary drive of the drill rig. When erecting the mast, check above the drilling rig for overhead obstructions or hazards, such as power lines, prior to lifting the mast. Perform a survey of underground and all other utilities prior to drilling to evaluate possible hazards. Establish and document a datum for measuring hole depth. This datum normally consists of the ground surface, or a stake driven into stable ground surface, or a drilling deck if used. If the hole is to be surveyed later for elevation, record and report the height of the datum to the ground surface.

6.2.2 *Hole Starting*—Push the auger column assembly below the ground surface and initiate rotation at a low velocity. Good practice for starting a straight hole normally requires minimum rotation speed while maintaining firm downward pressure to avoid whipping and widening of the top of the hole (1). An auger guide may be used (if available) to aid in starting the first auger to maintain a straight hole.

6.2.3 *Hole Advancement and Cuttings Return*—As the augers are rotating, apply down feed pressure to the HSA column to clean the hole and bring cuttings to the surface. Use rotation and penetration rates compatible with efficient cuttings returns. The use of excessive penetration rates faster than cuttings can be returned to the surface may result in the following: (1) cuttings which are packed into the auger flights, prohibiting newly penetrated materials from moving up the auger or, (2) forcing materials into the hole wall and increasing the chances of locking or binding of the HSA drill string. After advance of the auger string to the desired incremental depth in a hole advancement mode with pilot bits, rotation is normally continued without penetration for a time period long enough to ensure circulation of the cuttings up the flights.

6.2.4 *Pauses in Drilling*—Sampling or in situ testing can be performed at any depth by interrupting the advance of the augers and stopping rotation. During pauses in drilling the

HSA drill string can be held in place with an auger fork inserted at the surface. The fork will suspend the augers and prevent settling.

6.2.5 Drill Hole Advancement—Drilling at greater depths is accomplished by attaching additional hollow-stem auger sections to the top of the previously advanced HSA column assembly. If drilling with the pilot bit assembly in the HSA column using a wireline/overshot system; HSA sections can be added to the top of the HSA column without pulling the pilot bit assembly or adding any drill rods to advance the hole to a predetermined depth. When using the rod-type system, add a new inner rod along with an additional hollow-stem section.

6.2.6 Cuttings Removal and Classification—Periodically remove cuttings from around the top of the auger column, typically with a shovel. Soil cuttings above the ground water may be representative of deposits being penetrated if proper conveyance up the auger flight is maintained. Cuttings from below the ground water surface are likely to be mixed from varying formations in the hole and are usually not representative of deposits at the end of the auger. If cuttings are sampled for classification (Practice D 2488) and relation to lithology, report and document the intervals sampled.

6.2.7 Recording of Drilling Information—Record depths, progress, and location of samples or testing as drilling progresses. Monitor down feed pressures, rotation rates, and cuttings return during drilling. Note any indications of binding or locking of the augers during drilling. Observe the ease or difficulty of advancing the HSA drill string during drilling as it relates to the geologic strata being penetrated. Document occurrences of any significant abrupt changes and anomalies which occur during drilling. As drilling progresses, note and document drilling procedures such as water or drilling fluid added and losses, and intervals where equipment is changed or drilling method is changed.

6.3 Hole Advancement with Pilot Bit:

6.3.1 General Considerations—Following an increment of drilling, removal of the pilot bit assembly should be performed slowly so that the entrance of material into the bottom of the HSA column is minimized prior to sampling or installation of testing devices. The success of pilot assembly removal without disturbance will depend upon the following several principal factors: (1) the character of the soil at the auger head, (2) the water levels inside and outside the HSA column prior to removal of the pilot assembly, (3) the type of pilot assembly used, and (4) the speed of removal. As drilling progresses in saturated, granular materials, it usually becomes progressively more difficult to maintain the stability of the material below the auger column because of unbalanced hydraulic heads between outside ground water and inside the hollow stem. The stability of the material below the auger head may be enhanced by using special pilot assemblies, or maintaining fluid level in the HSA column during auger advancement and during retrieval of the pilot bit assembly (Fig. 4). Under some circumstances it may be effective to drill without using a pilot assembly. If a pilot assembly is not used, however, and water or drilling fluid is not injected into the auger column simultaneously with advancement, material often will enter the hollow stem of the auger column. In some cases when drilling in saturated granular

materials, a screened lead auger section may be used to help deter blow-in. The screened auger allows formation water to flow into the HSA column to help prevent water level differences and maintain a hydrostatic balance.

6.3.2 Knock Out Plugs—If sampling or in situ testing is not required during drilling for installation of an instrumentation device, the boring can be advanced (for some geologic conditions) using an expendable, knock-out plate or plug, or flexible center plus instead of a pilot assembly. Knock-out plates or plugs usually remain in the ground close to the instrumentation device. It may be necessary to fill or partially fill the auger stem with water or drilling fluid to prevent blow-in, or sanding in at the time of plate or plug removal. An auger head with an integral, hinged aperture cover or flexible center plug can be used to deter entrance of materials into the auger stem.

6.3.2.1 Flexible Plug—The flexible center plug system uses a plastic basket with flexible finger, inverted in the HSA column at the cutter head. The flexible center plug allows split spoon sampling through the flexible fingers and helps prevent water-bearing sands from entering the HSA column while advancing the augers.

6.3.3 Locking Problems, Blow-in—There may be instances, during insertion of the pilot bit, when difficulties are encountered in locking of the bit and getting it back to the bottom of the HSA column. If material is present in the hollow-stem auger, it may be necessary to lift the HSA column to engage the locking mechanism. The action of lifting the hollow-stem augers can cause subsurface disturbance. Blow-in can be minimized by venting or the use of fluids in the hollow-stem auger.

6.4 Intermittent Sampling or Field Testing—Sampling or field testing can be performed at any depth by interrupting the advance of the augers and stopping rotation. Solid sampling is usually accomplished by either of the following two methods: (1) drive, push, or core sampling or (2) soil coring using hollow-stem augers (see 6.5)

6.4.1 Soil sampling and in situ testing methods, some of which are listed in 2.2 and 2.3, are often used to obtain samples or perform tests at the base of the boring. Slowly remove the pilot assembly, if being used, and insert a sampler or testing device through the hollow stem of the auger column. The sampled or tested depth should be compared to the clean-out depth if the sampler is attached to the rods. This comparison is accomplished by resting the sampler or testing device at the bottom of the hole and comparing the apparent depth with the clean-out depth. If cuttings, cave in material, or sanding in is apparent, these conditions should be noted. Sampler barrels which drop past the cutting teeth of the augers may indicate excessive disturbance at the base of the drill hole. If there is material in the HSA column that does not allow for the sampler to rest at the augured depth below the end of the HSA bit, it may be necessary to allow the material to fall out of the HSA column. Actual depth of the sampler in relation to the bottom of the hole should be considered, not where the bottom of HSA string is setting. If in situ testing is performed below the base of the borehole, check for disturbance below the base of the borehole, and advance the testing instrument well in advance of any disturbance at the base of the boring.

6.5 Continuous or Intermittent Soil Sampling with the Double-Tube HSA Soil Coring System:

6.5.1 *Intermittent Sampling*—The pilot bit can be replaced at any time with the double-tube HSA core barrel assembly and samples taken at desired depths. Samples can be taken at selected intervals of concern and based on change of soils encountered.

6.5.2 *Continuous Sampling*—In the continuous soil sampling process a sampler barrel is used during hole advancement. Remove and replace barrels as drilling progresses. Detailed stratigraphic logging and sampling for geotechnical exploration may be obtained.

6.5.3 *Hole Advancement and Cuttings Return*—When using the double-tube HSA soil coring system, typically perform drilling at a rotary velocity of about 50 to 100 r/min. Advance the system to a depth equal to the length of the sample barrel, or where intermittent sampling or in situ testing is required, or until the cutter head assembly is advanced to the desired depth. When using the HSA double-tube soil sampling system, rotational speeds and rate of down feed may vary with the degree of resistance of the material being sampled. As the augers are rotating, apply down feed pressure to the HSA column. Cut away the material from around the inner barrel by the cutter head. The rotating action of the cutter head around the sampler barrel cutting shoe allows the inner sample barrel to push/core down over the column of material filling the inner barrel. Cuttings are directed to the HSA flights and conveyed to the surface by the rotating HSA column. Rotation to clean cuttings from the hole should be limited in the HSA double-tube soil sampling mode to prevent sample from being vibrated (loosen) out of the sample barrel. Rotation for borehole cleaning can be accomplished after removal of the HSA sample barrel prior to the beginning of the next sampling increment.

6.5.4 *Selection of HSA Sampling Barrel*—Depending on the exploration needs, different types of sample barrels may be used. Split barrels are often used for lithologic logging and soil classification. Split barrel samples are often taken in 5-ft (1.5-m) lengths. Sample length can be reduced to reduce disturbance. Undisturbed samples consistent with Practice D 4220, Class c and d are often taken in liners. For undisturbed sampling, it is important to adjust the clearance ratio and the lead distance to reduce disturbance. In general, satisfactory undisturbed samples are usually at least 3 in. (75 mm) in diameter and larger and sampling length is reduced to 2.5 ft (0.75 m).

6.5.4.1 Considerations for Undisturbed Sampling:

6.5.4.1.1 *Undisturbed Sampling*—If the goal of the investigation program is to obtain samples with minimal disturbance, lead distance and cutting shoe clearance ratio must be adjusted for optimum sample recovery. This will be a trial-and-error process. The ultimate goal in undisturbed sampling is to achieve core recovery as close to 100 % as possible with a sample that just fills the liner.

6.5.4.1.2 *Lead Distance Optimization*—The lead distance of the core barrel cutting shoe should be adjusted to obtain optimum sample recovery (see 5.7.4). With wireline systems, the lead distance can be checked by vertically suspending the

entire lead auger so that the inner barrel assembly can hang freely and then latch inside the lead auger.

6.5.4.1.3 *Clearance Ratio Optimization*—The clearance ratio of the cutting shoe should be optimized for the soil formations to be sampled (see 5.7.4). For undisturbed sampling, hold the liners in place in the sample barrel assembly by the cutting shoe which threads onto the end of the barrel. Cutting shoes are machined with different bit clearance ratios (see 3.1.2). Cutting shoe bit clearance ratios should be checked prior to use. Guidelines for bit clearance ratios for different soil types are as follows:

Bit clearance ratio %	Material
0 to ½	sands with little or no fines
½ to 1	silty sand, clay, silt
1 to 1½	expansive clay, shales, claystones

6.5.5 *General HSA Sampling Considerations*—When the bit or sample barrel assembly is removed and replaced, check the depth to the base of the boring where the end of the string rests and compare to the clean-out depth to evaluate hole quality. Hole depth is recorded by knowing the length of the auger assemblies and the actual amount of extension of the end of the sample barrel beyond the end of the HSA cutter head. This will facilitate accurate depth calculation of the sample taken and comparison of its position relative to the established surface datum. Excessive slough or cuttings within the hollow stem are undesirable and should be corrected by changes in technique, changes in equipment, or repair of equipment. Carefully record the start and stop depths of the sampling interval. Calculate the recovery. Sample recovery is the most important indicator of sample quality. To enhance sample recovery, the rate of penetration should be no greater than the speed at which the HSA cutter head is able to cut; that is, the downward force on the sampler barrel assembly should be a minimum. The speed of rotation should be limited to that which will not tear or break the soil during sampling (generally this varies from 40 to 125 r/min.) Important considerations for optimum sampling are lead distance and clearance ratio or head space of the cutting shoe and prevention of inner barrel rotation (5). Extension of the sample barrel shoe beyond the HSA cutter head depends on the soil type and should be the least amount which will result in a fully filled sample barrel (see 5.7.4).

6.5.6 Sample Barrel Recovery and Reinsertion

6.5.6.1 *Rod Systems*—After drilling the length of the sample barrel, stop, secure, and disconnect the HSA column from the drill rig drive connector. Disconnect the connecting rods inside the HSA column that may be attached to or extend through the rotary spindle of the drill rig. Remove the drill rotary head off the hole and hoist the rods connecting the sample barrel out of the HSA column. Replace the barrel by attachment of a new barrel to inner rods which are lowered back into the hollow-stem column and secured through the drive cap or rotary spindle attachment.

6.5.6.2 *Wireline Systems*—If a wireline/overshot system is used, after disconnecting the drill rig rotary drive connector from the top of the HSA column and removing the rotary head, lower the overshot retrieval tool down the HSA column to latch into the latching head on top of the sample barrel assembly. After the overshot is locked into the latching head assembly, hoist the sample barrel out of the HSA drill string on a wire

cable attached to a hydraulic winch on the drill rig. Remove the sample barrel and connect another sample barrel assembly to the latching head and hoist and lower down the HSA column by means of the overshot and wireline assembly until the latching head locks into the latching connector box (part of the HSA column above the lead HSA and cutter head). Release the overshot from the locking head above the sample barrel and hoist to the surface.

6.5.6.3 Reinsertion—Add the next HSA section to the top of the HSA column and connect to the drill rig rotary spindle. Connect inner connecting rods (if not the wireline system) to or through the rotary spindle before the auger drive adapter is connected to the top of the HSA column. In special cases, such as in loose sand, lift the HSA drill string by the drill rig to remove the auger holding fork, and then lower to the bottom of the hole where the previous sample stopped. Rotate and push the HSA column to begin the soil coring procedure again.

6.5.6.4 There may be instances, during insertion of the sample barrel, when difficulties are encountered in locking of the barrel and returning it back to the bottom of the HSA column. If material is present in the hollow-stem auger it may be necessary to lift the HSA column to engage the locking mechanism. This will allow the sample barrel assembly to fall to the bottom of the HSA column, forcing out the slough and reach the locking position. When the sample barrel assembly is connected to drill rods or hex rods to the top of the HSA column, the rods may have to be pushed with the hydraulics of the drill rig to the bottom of the HSA column to reach the proper depth to begin the next soil coring interval. When drilling in 5-ft (1.5-m) intervals, a shorter HSA coring interval may have to be run to allow for slough material. If 2.5-ft (0.75-m) sample intervals are being used, use of a 5-ft barrel will allow for accommodation of slough. Note and record sample intervals, recovery, and any slough, cuttings, fluid exposure, or evidence of rotation contained in the samples recovered.

6.5.7 Sample Testing and Handling—First measure samples for recovery upon retrieval. Handle and transport samples in accordance with Practice D 4220. Classify soil samples in accordance with Practice D 2488. Samples from split liners can be classified and stored in jars or bags. Report the locations of specimens removed for testing. Collect material for classification of samples in liners to be stored for laboratory testing from the ends of the sample. Trim and seal the sample ends for preservation. The average soil in-place unit weight can be determined (6). Moisture specimens can be obtained from the cutting shoe or liner trimmings. Report results and locations of any tests performed on cores such as Torvane or pocket penetrometer.

7. Drill Hole Monitoring and Completion

7.1 Monitoring—It is advisable to monitor ground water levels, if present, in the drill hole during and after drilling. Ground water elevations should be measured and documented during drilling. If ground water is not encountered or if the level is of doubtful reliability, such information should also be documented.

7.2 Installation of Instrumentation Devices:

7.2.1 Instrumentation devices, such as piezometers or inclinometers (see 2.4) are installed using hollow-stem augers following a three-step procedure: (1) drilling, with or without sampling, (2) removal of the pilot assembly, if being used, and insertion of the instrumentation device, and (3) incremental removal of the hollow auger column as completion materials such as backfill or grout is installed as required.

7.2.1.1 If materials enter the bottom of the auger hollow stem during removal of the pilot assembly, they can be removed with a bailer, other device, or fluid rotary drilling (see 2.4) .

7.2.1.2 Completion materials such as bentonite pellets, granules and chips, and grouts should be selected and installed to specific subsurface instrumentation requirements.

7.3 Other Completion Methods—Depending on requirements of the investigation it may be necessary to perform special installations with protective casings or to the backfilling. An example of special completion is for the seismic crosshole test (Test Methods D 4428) which requires grouted PVC casings. These installations are also performed using the three-step method in 7.2.1. Several methods are available for grouting of casings. It is desirable to use injection grouting where injection is performed at the base of the boring, and grouts are pumped up the annulus until they reach the surface indicating a continuous seal.

7.4 Drill hole Abandonment—If there are no needs for special completion or instrument installations for the drill hole, it should be backfilled for completion. The method of backfilling for abandonment depends on the requirements of the exploration program and should be specified as part of the program. Certain state and local regulations may apply. At a minimum, the surface of the hole should be backfilled to reduce potential hazard to those at the surface. In cases where the hole is to be backfilled completely, the condition of the hole should be evaluated and documented. Any zones of caving or blocking which preclude complete backfilling should be documented. Backfilling can be performed by addition of backfill materials from the surface or through injection by tremie pipes. When backfilling from the surface, either cuttings spoil, (only if suitable for replacement) bentonite pellets or granules, or select materials may be added. If complete backfilling is desired using surface methods, use of uniform backfill materials such as bentonite pellets or granules will reduce the possibility of bridging. The hole can be probed to test for bridging. The tremie methods ensure the best backfilling and should be performed when exploration plans require assurance of complete backfilling. Tremie methods consist of placing a small-diameter grout pipe near the base of the drill hole and pumping either cement or bentonite grouts to the surface while displacing any drill hole fluid. The tremie pipe is withdrawn in increments, but the tip is maintained below the grout surface. Typical grout consistencies depend on equipment and the needs of the exploration program. Typical grout mixtures are given in Practice D 5092 and Test Methods D 4428.

8. Report

8.1 Report information in accordance with Guide D 5434 of “Subsurface Explorations of Soil” and identified as necessary

and pertinent to the needs of the exploration program. Information is normally required for the project, exploration type and execution, drilling equipment and methods, subsurface conditions encountered, ground water conditions, sampling events, and installations.

8.2 Other information in addition to that mentioned in Guide D 5434 should be considered if deemed appropriate and necessary to the requirements of the exploration program. Additional information should be considered as follows:

8.2.1 *Drilling Methods:*

8.2.1.1 Report description of the hollow-stem auger system including the head, drive, and pilot assemblies. Provide information on drill hole and sample sizes. Note intervals of equipment change or drilling method changes and reasons for change.

8.2.1.2 Report type, quantities, and locations of use of additives such as water added to the hole. If changes to the circulating medium are made, such as addition of water, the depth(s) or interval(s) of these changes should be documented.

8.2.1.3 Report descriptions of down-feed pressures, rotation rates, and cuttings returns over intervals drilled. Note locations of loss of cuttings return and probable cause. Note any indications of binding or locking of the augers during drilling. Observe the ease of drilling during advancement as it relates to the geologic strata being penetrated. Document occurrences of any significant abrupt changes and anomalies in drilling conditions which occur during drilling.

8.2.1.4 If blow-in or sanding-in is evident in the HSA column, note occurrences and the amount. As the drilling progresses, note and document drilling procedures such as

cuttings return, water added and losses, and intervals where equipment is changed or drilling method is changed.

8.2.2 *Sampling:*

8.2.2.1 Report depth interval sampled, recovery, classification, and any other tests performed, such as moisture or soil in-place unit weight determinations.

8.2.2.2 When core sampling or undisturbed sampling at the base of the boring, report condition of the base of the boring prior to sampling and report any slough or cuttings present in the recovered sample.

8.2.2.3 If cuttings are sampled for classification and relation to lithology, report and document the intervals sampled.

8.2.2.4 During insertion of the continuous sample barrel note any difficulties in locking of the barrel. Note any disturbances or evidence of rotation observed in the samples recovered.

8.2.3 *In situ Testing:*

8.2.3.1 For devices which were inserted below the base of the drill hole, report the depths below the base of the hole and any unusual conditions during testing.

8.2.3.2 For devices testing or seating at the drill hole wall, report any unusual conditions of the drill hole wall such as inability to seat pressure packers.

8.2.4 *Completion and Installations*—A description of completion materials and methods of placement, approximate volumes placed, intervals of placement, methods of confirming placement, and areas of difficulty or unusual occurrences.

9. Keywords

9.1 continuous sampling; double-tube auger; drilling; hollow-stem augers; soil coring; soil sampling; subsurface exploration

REFERENCES

- (1) *DCDMA Drilling Safety Manual*, Drilling Equipment Manufacturers Assn., 3008 Millwood Ave., Columbia SC 29205, 1991.
- (2) Shuter, E., and Teasdale, W.E., "Application of Drilling, Coring, and Sampling Techniques to Test holes and Wells - Chapter F1 - Techniques of Water-Resource Investigations of the United States Geological Survey," U.S. Government Printing Office, Washington, DC, 1989.
- (3) *Groundwater and Wells*, F.G. Driscoll, 2nd ed, Johnson Filtration Systems, St. Paul, MN, 1989.
- (4) O'Rourke, J.E., Gibbs, H.J., and O'Connor, K.O., "Core Recovery Techniques for Soft or Poorly Consolidated Materials," *Final Report*, Contract No. J0275003, U.S. Bureau of Mines, Department of Interior, Washington, DC, April 28, 1978.
- (5) *Drillers Handbook*, T.C. Ruda and P.J. Bosscher, eds, National Drilling Contractors Assn., 3008 Millwood Ave., Columbia, SC 29205, June 1990.
- (6) USBR D-7115, "Undisturbed Sampling Using Mechanical Drilling Methods," Part II, *Earth Manual*, 3rd ed, U.S. Department of Interior, Bureau of Reclamation, U.S. Government Printing Office, Washington, DC, 1990.
- (7) *DCDMA Technical Manual*, Drilling Equipment Manufacturers Assn., 3008 Millwood Ave., Columbia, SC 29205, 1991.

ASTM International takes no position respecting the validity of any patent rights asserted in connection with any item mentioned in this standard. Users of this standard are expressly advised that determination of the validity of any such patent rights, and the risk of infringement of such rights, are entirely their own responsibility.

This standard is subject to revision at any time by the responsible technical committee and must be reviewed every five years and if not revised, either reapproved or withdrawn. Your comments are invited either for revision of this standard or for additional standards and should be addressed to ASTM International Headquarters. Your comments will receive careful consideration at a meeting of the responsible technical committee, which you may attend. If you feel that your comments have not received a fair hearing you should make your views known to the ASTM Committee on Standards, at the address shown below.

This standard is copyrighted by ASTM International, 100 Barr Harbor Drive, PO Box C700, West Conshohocken, PA 19428-2959, United States. Individual reprints (single or multiple copies) of this standard may be obtained by contacting ASTM at the above address or at 610-832-9585 (phone), 610-832-9555 (fax), or service@astm.org (e-mail); or through the ASTM website (www.astm.org).