



Standard Test Method for Measuring Bulk Density Values of Powders and Other Bulk Solids¹

This standard is issued under the fixed designation D 6683; the number immediately following the designation indicates the year of original adoption or, in the case of revision, the year of last revision. A number in parentheses indicates the year of last reapproval. A superscript epsilon (ϵ) indicates an editorial change since the last revision or reapproval.

1. Scope

1.1 This test method covers an apparatus and procedure for determining a range of bulk densities of powders and other bulk solids as a function of compaction pressure.

1.2 This test method should be performed in the laboratory under controlled conditions of temperature and humidity.

1.3 This test method is similar to those of B 212-89(1995) Test Method for Apparent Density of Free-Flowing Metal Powders, D 29-86(1994) Test Methods for Sampling and Testing Lac Resins, D 2854-89(1993) Test Method for Apparent Density of Activated Carbon.

1.4 The values stated are in SI Units and are to be regarded as the standard.

1.5 *This standard does not purport to address all of the safety concerns, if any, associated with its use. It is the responsibility of the user of this standard to establish appropriate safety and health practices and determine the applicability of regulatory limitations prior to use.*

2. Referenced Documents

2.1 ASTM Standards:

D 653 Terminology Relating to Soil, Rock, and Contained Fluids²

D 4753 Specification for Evaluating, Selecting, and Specifying Balances and Scales for Use in Testing Soil, Rock, and Related Construction Materials²

3. Terminology

3.1 Definitions of terms used in this test method shall be in accordance with Terminology D 653.

3.2 Definitions of Terms Specific to This Standard:

3.2.1 *area of the lid (A_l)*—this is the area of the cover in m².

3.2.2 *incremental height (h_m)*—the height due to the addition of weights in m.

3.2.3 *initial bulk density (ρ)*—the initial density (Kg/m³) when the cup is filled, prior to compressing the material with the weights.

3.2.4 *initial height (H_i)*—the initial height prior to compressing the specimen in m.

3.2.5 *maximum consolidation pressure (P_m)*—the maximum desired pressure at which a bulk density value is to be determined in kPa.

3.2.6 *maximum force (W_m)*—the weight that produces the maximum consolidation pressure (P_m) appropriate for the application: ($W_m = P_m \times A_l$). Units are in kN.

4. Summary of Test Method

4.1 Bulk density values are determined by measuring the volume change of a given mass of bulk solid under increasing compaction pressure conditions.

5. Significance and Use

5.1 The data from this test can be used to estimate the bulk density of materials in bins, hoppers and for material handling applications such as silos.

5.2 The test results can be greatly affected by the sample selected for testing. For meaningful results it is necessary to select a representative sample of the particulate solid with respect to moisture content, particle size distribution and temperature. For the tests an appropriate size sample should be available, and a fresh material should be used for each individual test specimen.

5.3 Initial bulk density may or may not be used as the minimum bulk density. This will depend on the material being tested.

5.4 Bulk density values may be dependent upon the magnitude of the load increments. Traditionally, the load is doubled for each increment resulting in a load-increment ratio of 1. Smaller than standard load increment ratios may be desirable for materials that are highly sensitive to the load increment ratio.

5.5 Bulk density values may be dependent upon the duration of each load increment. Traditionally, the load duration is the same for each increment and equal to 15 s. For some materials, the rate of consolidation is such that complete consolidation (dissipation of excess pore pressure) will require significantly more than 15 s.

6. Apparatus

A schematic of the arrangement of the test apparatus of the

¹ This test method is under the jurisdiction of ASTM Committee D18 on Soil and Rock and is the direct responsibility of Subcommittee D18.24 on Characterization and Handling of Powders and Bulk Solids.

Current edition approved June 10, 2001. Published October 2001.

² *Annual Book of ASTM Standards*, Vol 04.08.

system is shown in Fig. 1.

6.1 *Balance*, having a capacity to determine mass by using weight per class GP1 scale as per method ASTM document D 4753.

6.2 *Stand*, to support the density cup, and to mount the dial indicator. The stand must be level and securely mounted on a vibration free base to support the test apparatus.

6.3 *Density Cup*, with cover to contain the test specimen. Density cup cover has a ball mounted in the center. The density cup is to be a cylindrical cup with the minimum cell diameter of 64 mm and a minimum height of 21 mm or five times the diameter of the largest particle whichever results largest cell height. The ratio of diameter to height must be at least 3:1.

6.4 *Weights*, to be used with the weight hanger for consolidation purposes.

6.5 *Weight Hanger*, to support weights, and guide load onto the density cup cover.

6.6 *Dial or Digital Displacement Indicator*, to measure height. Dial indicator should be able to read in 0.02 mm increments.

6.7 *Plug*, or gage block is used to zero the dial indicator and should equal in length to the inside height of the density cup.

6.8 *Weight Support*, to support weights as they are added to compress the material.

7. Preparation of Apparatus

7.1 Calibrate the balance and set it on a sturdy table or bench for accurate measurement.

7.2 Make sure that the density cup and cover are clean and

free of foreign material prior to starting each new test.

7.3 Calibrate the weights and keep them clean of foreign material.

7.4 Select a minimum of five weights to be used according to the following procedure. Additional weights may be used if more data points are desired or required.

7.4.1 Calculate the maximum force W_m . (This will be one of the weights.)

7.4.2 Divide the maximum force W_m in half then in half again and continue until at least five weights have been identified.

8. Procedure

8.1 Determine the mass of the density cup and record this value to the nearest 0.1 g on a test data sheet as the tare weight.

8.2 Determine the weight of the cover and the weight hanger (this weight along with the spring force from the dial indicator, become the initial weight). Be sure this weight is less than the smallest weight to be used. These are to be recorded to the nearest 0.1 g on a test data sheet, and the total of these will be used as the first compression weight.

8.3 Insert the plug, (or gage block) inside the density cup. Place the cover on the plug, next place the density cup on the test stand, and then place the weight hanger on the cover. Position the dial indicator on the top of the weight hanger, then set the dial indicator to zero. Now carefully lift the plunger of the dial indicator far enough to be able to slide the density cup out from under the dial indicator so when the material is put

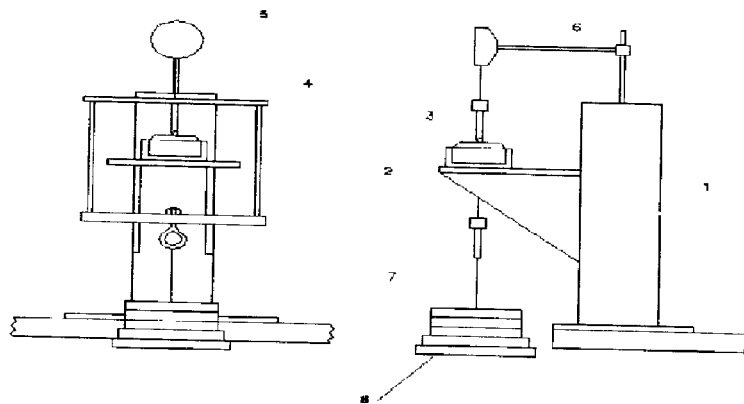

- | | |
|------------------|--------------------------|
| 1. Stand | 5. Dial indicator |
| 2. Density cup | 6. Dial indicator holder |
| 3. Cover | 7. Weights |
| 4. Weight hanger | 8. Mass support |

FIG. 1 Test Apparatus

into the density cup, you won't accidentally bump the dial indicator.

8.4 Remove the weight hanger, then the cover and plug.

8.5 Place the test specimen into a mixing bowl, and stir the material with a spatula to be assured the material hasn't agglomerated from transit. Avoid segregation of material.

8.6 Carefully spoon the material into the density cup as loosely as possible to the point of overflowing. Scrape off all excess material using a straight fiat scraper. The angle of the scraper as it is drawn across the density cup should be such that it does not compress the sample in the cup. Allow the sample to set for approximately one minute. If the sample has settled below the top of the density cup add additional material to bring the level above the cover and scrape again. Weigh the density cup again with the material in the cup. Be careful not to spill any material. Record this value to the nearest 0.1 g on the test data sheet.

8.7 Place the density cup back on the stand, then carefully place the cover so it is centered on the density cup. Place the centering rod of the weight hanger over the ball which is mounted to the center of the cover, and is used as a pivot for the weight hanger. Slowly lift the plunger of the dial indicator, and slide the cup, cover and hanger under the plunger. Allow the plunger to come down and rest on the weight hanger. Record the height indicated by the dial indicator due to the mass of the cover, the weight hanger, and the spring force to the nearest 0.02 mm on the test data sheet. This is the first height.

8.8 Hang the weight support on the bottom of the weight hanger. Record the height due to this additional weight to the nearest 0.02 mm on the test data sheet.

8.9 Record the height to the nearest 0.02 mm with each weight that is added. Record each weight added allowing 15 s between the change in loads as well as the change in height, as indicated by the dial indicator. Usually 5 weights will be sufficient to accomplish the maximum compaction. However, there may be times when more than 5 weights are required. If this is the case, continue to add weights until there is no further compaction indicated by additional height on the dial indicator. The number of points to establish the desired consolidation pressure is based on how the data will be used, and will dictate how many weights must be used.

NOTE 1—At the completion of the test, visually inspect the cover's position with respect to the density cup. If it is visibly tilted, the test is not valid and should be repeated, paying particular attention to procedure steps 8.5 and 8.6. Tilting of the lid is most often caused by non-uniform initial bulk density in the density cup.

8.10 From the data recorded, calculate and plot the bulk density and consolidation pressure.

9. Calculation

9.1 To calculate the initial bulk density (V_o), subtract the mass of the density cup from the value obtained of the density cup with material in it. This mass is in kilograms. To calculate the volume of the density cup multiply the area of the inside diameter of the cup by the depth of the cup.

$$Vol_1 = \pi \times (D)^2/4 \times h_1 \text{ (m}^3\text{)}$$

where:

D = the inside diameter of the density cup, in m,

h_1 = the overall inside depth of the density cup, in m, and

initial density = net mass/ Vol_1 .

9.2 Calculate the volume based on the original depth of the cup, minus the height indicated by the dial indicator [$\pi \times (D)^2/4$]. With each additional weight added, a new density can be calculated. To calculate each consolidation pressure, add the mass of the cover, the mass of the weight hanger, the spring force of the dial indicator and any additional weights used then divide by the inside area of the density cup.

$$Vol_n = \pi \times (D)^2/4 \times h_n$$

where:

h_n = the new depth in m for each additional weight.

10. Report

10.1 A curve is then generated from the data obtained with this test. The heading of the curve would be, "Bulk density as a function of consolidation pressure," with the "x" axis being the consolidation pressure in kPa (1000 N/m²) and the "y" axis being the bulk density in kg/m³. The data is then plotted on a linear graph. As an alternate, the data could be plotted on a log-log graph.

11. Precision and Bias

11.1 Data are being evaluated to determine the precision of this method. In addition, Subcommittee D18.24 is seeking pertinent data from users of this test method.

11.2 There is no accepted reference value for this test method, therefore, bias cannot be determined.

11.3 In almost all cases there is not a reference value for test methods under the jurisdiction of D18. Therefore, the statement as given above should be used.

12. Keywords

12.1 bulk density; bulk solids; compaction pressure; powder

ASTM International takes no position respecting the validity of any patent rights asserted in connection with any item mentioned in this standard. Users of this standard are expressly advised that determination of the validity of any such patent rights, and the risk of infringement of such rights, are entirely their own responsibility.

This standard is subject to revision at any time by the responsible technical committee and must be reviewed every five years and if not revised, either reapproved or withdrawn. Your comments are invited either for revision of this standard or for additional standards and should be addressed to ASTM International Headquarters. Your comments will receive careful consideration at a meeting of the responsible technical committee, which you may attend. If you feel that your comments have not received a fair hearing you should make your views known to the ASTM Committee on Standards, at the address shown below.



This standard is copyrighted by ASTM International, 100 Barr Harbor Drive, PO Box C700, West Conshohocken, PA 19428-2959, United States. Individual reprints (single or multiple copies) of this standard may be obtained by contacting ASTM at the above address or at 610-832-9585 (phone), 610-832-9555 (fax), or service@astm.org (e-mail); or through the ASTM website (www.astm.org).