



Designation: D 1761 – 88 (Reapproved 2000)

Standard Test Methods for Mechanical Fasteners in Wood¹

This standard is issued under the fixed designation D 1761; the number immediately following the designation indicates the year of original adoption or, in the case of revision, the year of last revision. A number in parentheses indicates the year of last reapproval. A superscript epsilon (ϵ) indicates an editorial change since the last revision or reapproval.

This standard has been approved for use by agencies of the Department of Defense.

INTRODUCTION

The use of wood and wood-base materials in many structural and other applications often involves the use of mechanical fasteners, such as nails, screws, bolts, lag screws, and connectors. Data on the strength and performance of such fasteners are frequently needed for design and for comparative purposes. Tests of mechanical fasteners (except nail withdrawal) have been generally regarded as special tests and have not been included in the standard methods already established for evaluating the properties of wood. Many such special tests have been extensively used over a considerable period but have not previously been established as standards. Presented herewith are methods of conducting tests for nail, staple, and screw (except machine screws) withdrawal resistance; lateral load transmission by nail, staple, screw, bolt, and timber connector; and load transmission by nail plates and joist hangers. The use of standard methods for these tests is recommended as a means of obtaining comparable data and of eliminating variables in test results because of variations in testing methods.

The tests appear in the following order:

Nail, Staple, or Screw Withdrawal Test	Sections 1 to 12
Lateral Nail, Staple, or Screw Resistance Test	13 to 20
Testing Bolted and Timber Connector Joints	21 to 30
Tension Tests of Plate-Type Connector Joints	31 to 40
Joist Hanger Tests	41 to 50
Precision and Bias	51

NAIL, STAPLE, OR SCREW WITHDRAWAL TEST

1. Scope

1.1 These test methods provide a basic procedure for evaluating the resistance of wood and wood-base materials to direct withdrawal of nails, staples, and screws. Spikes are included as nails in this standard.

1.2 The tests also provide a basis for determining comparable performance of different types and sizes of nails, staples, and screws in direct withdrawal from wood and wood-base materials.

1.3 *This standard does not purport to address all of the safety problems, if any, associated with its use. It is the responsibility of the user of this standard to establish appropriate safety and health practices and determine the applicability of regulatory limitations prior to use.*

2. Referenced Documents

2.1 ASTM Standards:

D 143 Methods of Testing Small Clear Specimens of Timber²

D 2016 Test Methods for Moisture Content of Wood³

D 2395 Test Methods for Specific Gravity of Wood and Wood-Base Materials²

E 4 Practices for Force Verification of Testing Machines⁴

2.2 Other Standards:

Federal Specification FF-W-92 for Washers, Metal, Flat (Plain)⁵

ANSI B18.6.1 American National Standard for Slotted and Recessed Head Wood Screws⁵

3. Summary of Test Method

3.1 Specimens consist of prisms of wood or wood-base products, with nails, staples, or screws driven at right angles to

¹ These test methods are under the jurisdiction of ASTM Committee D07 on Wood and are the direct responsibility of Subcommittee D07.05 on Wood Assemblies.

Current edition approved December 30, 1988. Published March 1989. Originally published as D 1761 – 60 T. Last previous edition D 1761– 77(1988)⁶¹.

² *Annual Book of ASTM Standards*, Vol 04.10.

³ Discontinued, see *1988 Annual Book of ASTM Standards*, Vol 04.09.

⁴ *Annual Book of ASTM Standards*, Vol 03.01.

⁵ Available from Standardization Documents Order Desk, Bldg. 4 Section D, 700 Robbins Ave., Philadelphia, PA 19111-5094, Attn: NPODS.

one or more faces. The fasteners are withdrawn at a uniform rate of speed by means of a testing machine, and the maximum load is recorded. Supplementary physical properties of the wood or wood-base product are also determined.

4. Significance and Use

4.1 The resistance of a species of wood or a wood-base product to direct withdrawal of nails, staples, or screws is a measure of its ability to hold or be held to an adjoining object by means of such fasteners. Factors that affect this withdrawal resistance include the physical and mechanical properties of the wood; the size, shape, and surface condition of the fasteners; the speed of withdrawal; physical changes to wood or fasteners between time of driving and time of withdrawal; orientation of fiber axis; and the occurrence and nature of prebored lead holes.

4.2 By using a standard size and type of nail, staple, or screw, withdrawal resistance of a wood species or wood product can be determined, and such values for two or more wood species or wood products can be compared. Throughout the method this is referred to as the basic withdrawal test. Similarly, comparative performances of different sizes or types of nail, staple, or screw can be determined by using a standard procedure with a particular wood or wood product, which eliminates the wood or the wood product as a variable. Since differences in test methods can have considerable influence on results, it is important that a standard procedure be specified and adhered to, if test values are to be related to other test results.

5. Apparatus

5.1 *Testing Machine*—Any suitable testing machine that is capable of operation at a constant rate of motion of the movable head and has an accuracy of $\pm 1\%$ when calibrated in accordance with Practices E 4.

5.2 *Grips*—A gripping device shaped to fit the base of the fastener head and of such a design as to allow accurate specimen positioning and true axial loading, is required. A clamping assembly that will hold the specimen to one platen of the machine is also required. A suitable test mechanism for screw withdrawal is illustrated in Fig. 1.

6. Test Materials

6.1 Nails:

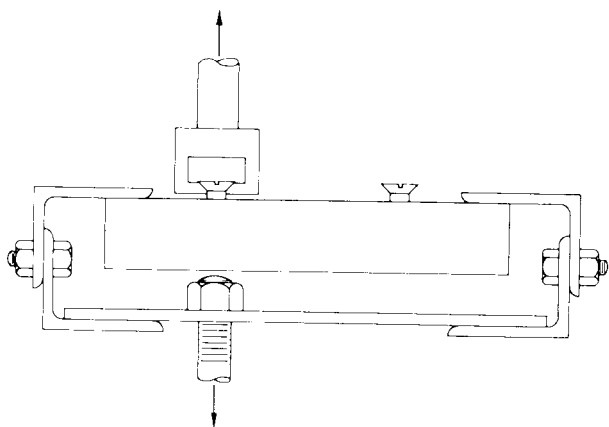

FIG. 1 Diagram of Assembly for Screw Withdrawal Test

6.1.1 Nails used for basic withdrawal tests shall be bright plain-shank diamond-point round-wire, low-carbon-steel nails nominally 0.113 in. (2.87 mm) in diameter (Note 1). They shall be cleaned before use to remove any coating or surface film that may be present as a result of manufacturing operations and exposure. Each nail shall be used but once.

NOTE 1—A sixpenny common wire nail meets this requirement.

6.1.2 For determining holding ability of different sizes or types of nails in wood or wood products, the respective sizes and types of nail will be as circumstances dictate. These nails shall be representative of the normal manufacturing process, and special cleaning of the shank shall normally not be undertaken.

6.2 Staples:

6.2.1 Staples used for basic leg withdrawal resistance shall be standard 2 in. (51 mm) long, $\frac{7}{16}$ in. (11.1 mm) crown, 15 gage (0.072 in.) (1.83 mm) galvanized steel staples. They shall be cleaned before use. Each staple shall be used but once.

6.2.2 For determining holding ability of different types or sizes of staples in wood or wood products, the respective staples shall be representative of the normal manufacturing process, and special cleaning of the legs shall not normally be undertaken.

6.3 Screws:

6.3.1 Screws used for basic withdrawal tests shall be standard 1-in. (25 mm) No. 10-gage flathead low-carbon-steel wood screws as described in the American National Standard for Slotted and Recessed Head Wood Screws (ANSI B18.6.1). Each screw shall be used but once.

6.3.2 For determining holding ability of different sizes and types of screws in wood or wood products, the respective size and types of screw will be as circumstances dictate. These screws shall be representative of the normal manufacturing process.

6.4 *Wood and Wood Products*—Prisms shall be cut accurately and square to the required dimensions, and be planned smooth. They shall be of representative density, free of defects and growth irregularities, and of specified moisture content.

7. Sampling

7.1 Sampling should provide for selection of representative test material on an objective and unbiased basis, covering an appropriate range in density and properties as circumstances suggest.

7.2 The tests should be sufficiently extensive to provide reliable results. Where analysis by statistical procedures is contemplated, experience and sometimes advance estimates can be used to establish the scope of testing and type of sampling needed to achieve the expected reliability.

NOTE 2—The precision required, and thus the manner of sampling and number of tests, will depend upon specific objectives. No specific criteria therefore can be established. General experience indicates that the coefficient of variation from tests of fasteners ranges from about 15 to 30%. When such is the case, precision of 5 to 10%, with 95% confidence (an often accepted general measure of reliability for testing wood) cannot be achieved without making a rather large number of tests. The present recommendation is to make at least 10 replications for each variable as a minimum requirement.

8. Test Specimen

8.1 *Nail and Staple Withdrawal:*

8.1.1 For basic withdrawal tests from wood, the wood prism shall be 2 by 2 by 6 in. (51 by 51 by 152 mm). Nails of the type outlined in 6.1.1 and staples of the type outlined in 6.2.1 shall be driven at right angles to the face of the specimen to a total penetration of $1\frac{1}{4}$ in. (32 mm). Two fasteners shall be driven into a tangential surface, two into a radial surface, and one into each end. End and edge distances shall be sufficient to avoid splitting. In general, edge distances should not be less than $\frac{3}{4}$ in. (19 mm), end distances not less than $1\frac{1}{2}$ in. (38 mm) and two fasteners shall not be driven in line with each other or less than 2 in. (51 mm) apart on radial or tangential faces. Nails shall be driven manually with a hammer. Staples shall be inserted with an appropriate tool, as nearly as possible perpendicular to the specimen surface, with the staple crown at a 45° ($\pm 10^\circ$) angle to the grain direction of the prism.

8.1.2 For basic withdrawal tests from wood products, the test prism shall be a single thickness of convenient size not smaller than 3 in. (76 mm) wide and 6 in. (152 mm) long. Nails of the type outlined in 6.1.1 and staples of the type outlined in 6.2.1 shall be driven through the wood product at right angles to the face, permitting at least $\frac{1}{2}$ in. (13 mm) of the shank portion to remain above the surface. Nails shall be driven manually by means of a hammer. Staples shall be inserted with an appropriate tool as in 8.1.1, but if there is no discernible grain direction in the wood product, the staple crown shall be oriented at a 45° ($\pm 10^\circ$) angle to the length of the prism.

8.1.3 For determining the withdrawal resistance of particular sizes and shapes of nails or staples in wood or wood products, the specimen shall be of convenient size to accommodate the quantity of fasteners to be tested in each specimen, without exceeding the edge and end distances and spacings necessary to avoid splitting. In wood, fasteners should be driven to 70 % of their length; in thin panel wood products they should be driven completely through the thickness with at least $\frac{1}{2}$ in. (13 mm) of the shank portion remaining above the surface. The fasteners shall be driven by the method intended to be used in practice, that is, either manually with a hammer, or with an applicator or appropriate tool if this is the normal method.

8.1.3.1 If the withdrawal resistance may be influenced by the material through which the fastener is to be driven, the fastener shall be driven through the fastened member (cleat) into the fastening member.

8.2 *Screw Withdrawal:*

8.2.1 For basic withdrawal tests from wood, the specimen shall be 2 in. (51 mm) wide, 6 in. (152 mm) long, with depth at least equal to the length of the screw. Two screws of the type outlined in 6.2.1 shall be threaded into lead holes at right angles to the tangential face, to a total penetration equal to the length of the threaded portion. End and edge distance shall be sufficient to avoid splitting, which in general will be at least $\frac{3}{4}$ in. (19 mm) from the edge and $1\frac{1}{2}$ in. (38 mm) from the end, and spacing will be at least $2\frac{1}{2}$ in. (63 mm). The size of the lead hole shall be 70 % of the root diameter of the screw for softwoods and hardwoods and shall extend $\frac{1}{2}$ in. (13 mm) into the face of the specimen. The screws may be coated with

paraffin wax or other similar lubricant when necessary to facilitate driving.

8.2.2 For basic withdrawal tests from wood products, the specimen shall be 3 in. (76 mm) in width, and 6 in. (152 mm) in length. The depth of the specimen shall be at least equal to the length of the screw, and it may be necessary to glue together two or more thicknesses of material to provide the required depth. Screws of the type outlined in 6.2.1 shall be threaded into the specimen a distance of $\frac{2}{3}$ in. (17 mm) at midwidth, at least 2 in. (51 mm) from the end of the specimen. The size of lead hole shall be 70 % of the root diameter of the screw and it shall extend $\frac{1}{2}$ in. (13 mm) into the face of the specimen. The screws may be coated with paraffin wax or other similar lubricant when necessary to facilitate driving.

8.2.3 For determining the withdrawal resistance of particular sizes and types of screws in wood or wood products, the specimen shall be of convenient size to accommodate the quantity of screws to be tested in each specimen, without exceeding the edge and end distances and spacings necessary to avoid splitting. Screws shall be threaded into the specimen for the length of the threaded portion of the shank or two thirds of the shank length if it is threaded throughout. The size of lead hole, if one is to be drilled, shall be 70 % of the root diameter of the screw for a distance of one half of the screw length.

8.2.3.1 If the withdrawal resistance may be influenced by the material through which the screw is to be threaded the screw shall be threaded through a held member into the holding member.

9. Conditioning

9.1 Nail, staple, and screw withdrawal tests are normally made on seasoned material. The wood or wood product, whether kiln dried or air-dried, shall be stored in a room having a controlled temperature of $20 \pm 3^\circ\text{C}$ ($68 \pm 6^\circ\text{F}$) and a controlled relative humidity of $65 \pm 3\%$ for a period sufficiently long to bring it to approximate equilibrium. The fasteners shall not be driven until equilibrium is attained in the wood component.

9.2 Where required, withdrawal tests may be made on drier, partially seasoned or unseasoned material. It may sometimes be desired to apply the fasteners to unseasoned material and allow the completed specimen to season prior to withdrawal. As in 9.1 these specimens should attain the desired moisture equilibrium in a controlled atmosphere to ensure uniform moisture content at the time of test. Soaking in water will produce and maintain an unseasoned condition of the wood, but it may result in an extremely high moisture content, particularly at the surface, and undesirable and nonrepresentative corrosion of the fasteners near the wood surface.

10. Procedure

10.1 *General*—Except for special circumstances requiring delayed withdrawal, withdraw fasteners as quickly as practical after driving, and in all cases within 1 h.

10.2 *Basic Loading Method:*

10.2.1 Where the specimen consists of only the fastening prism and the fasteners, withdraw the fasteners by means of a tensile force applied at a uniform rate of withdrawal. Attach the specimen to one platen of the testing machine. Attach the

fastener head to a suitably designed grip which is fastened to the other platen through a universal joint. Apply the load by separation of the platens of the testing machine at a uniform rate of withdrawal. Read the maximum load required to withdraw the fastener from the wood or wood product to three significant figures. Disregard test values resulting from any failure of the fastener in the evaluation of the performance of wood and wood-base materials but report them; consider such failures in the evaluation of the performance of different types and sizes of fasteners. In such cases, an additional replication is desirable.

10.2.2 Where the specimen consists of a fastening prism plus one or more (cleats) fastened thereto with a fastener, two test procedures are possible: (a) The fastened member can be grasped and pushed or pulled away from the fastening prism in the axial direction of the fastener, whereby the fastener head exerts a force on the fastened member. Under this procedure, if the fastened member exerts less resistance to the passage of the fastener head than the fastening member exerts on fastener withdrawal head pull-through can occur. In such a case, the pull-through resistance of the fastened material will be indicated. (b) The fastened member can be split off and the fastener withdrawn as in 10.2.1.

10.3 *Special Loading Methods*—It may sometimes be necessary to determine the resistance to withdrawal as a result of an impact force or by repetitive loads. In the case of the former, this can be accomplished with standard apparatus such as the U.S. FPL toughness testing machine suitably modified to hold and grip the withdrawal specimen. The latter test may require the use of a cycling or pulsating loading head. The resulting data are based on the displacement angle of the pendulum and the forces resulting from the setting of the repetitive loading mechanism, respectively, required to withdraw the fastener from the wood or wood product. Disregard test values resulting from any failure of the fastener in the evaluation of the performance of wood and wood-base materials but report if desired; consider such failures in the evaluation of the performance of different types and sizes of fasteners. In such cases, an additional replication is desirable.

10.4 *Speed of Testing:*

10.4.1 For the basic loading method for fastener withdrawal, apply the load throughout the test at a uniform rate of platen separation of 0.10 in. (2.54 mm)/min \pm 25 %.

10.4.2 For special loading methods, special rates of withdrawal may be required. Record the rate used and the reasons for choosing it in the report.

NOTE 3—The rate of platen separation shall mean the free-running, or no-load, crosshead speed for testing machines of the mechanical drive type, and the loaded crosshead speed for testing machines of the hydraulic loading type.

10.5 *Supplementary Tests*—If information on the actual withdrawal during load application is desired or may be of influence on the interpretation of the withdrawal resistance of a given fastener, measure and record such withdrawal, in inches, at given withdrawal loads or at the ultimate withdrawal resistance, in pounds, to three significant numbers. Under given conditions, it may be expeditious to obtain an automatic plot of withdrawal load versus withdrawal distance in order to

determine the stiffness of the joint and the work involved up to a given point of withdrawal of the fastener under construction.

10.6 *Minor Tests*—Determine the oven-dry specific gravity and moisture content of the wood or wood products, both during driving and withdrawal of the fastener. Procedures for determining these properties are given in Test Methods D 2016 and D 2395.

11. Report

11.1 The report shall include the following:

11.1.1 Failure loads for individual fasteners, average test values, and statistical evaluation of the test data if justified,

11.1.2 A complete description of the test method and loading procedure used,

11.1.3 A description of the specimen, including the dimensions of the wood or wood-product components, size of fastener, end and edge distances, and spacings,

11.1.4 Number of tests,

11.1.5 Specific gravity and moisture content of wood components,

11.1.6 Details of any deviations from the prescribed or recommended methods as outlined in the standard, and

11.1.7 Details of any factors not included above that might have a bearing on results.

12. Precision and Bias

12.1 The precision and bias of this test method have not yet been determined.

LATERAL NAIL, STAPLE, OR SCREW RESISTANCE TEST

13. Scope

13.1 This test method covers the determination of the resistance to lateral movement offered by a single nail, staple, or screw in wood members. The test provides comparative data for various species of wood. This general test method can also be used for evaluating other types and sizes of fastenings either in wood or other building materials such as plywood, hardboard, etc., or combinations of materials. Furthermore, where required for specific purposes, the general method can be used for evaluating the lateral resistance of sizes of nails, staples, and screws other than those specified, and joints employing two or more fasteners. It is recommended that when such tests are made, the specified procedure be followed as closely as possible and all deviations be completely described.

14. Test Nails, Staples, or Screws

14.1 Nails used shall be bright plain-shanked medium diamond-point steel nails nominally 0.131 in. (3.33 mm) in diameter and 2½ in. (63 mm) in length, with a head ⅜ in. (7.14 mm) in diameter. The nails selected for test shall be representative of the product. Each nail shall be used only once. The actual size and details of the nails selected shall be recorded, including data on the properties of the metal.

NOTE 4—An eightpenny common wire nail meets this requirement.

14.2 Staples used shall be standard 2 in. (51 mm) long ⅞ in. (11.1 mm) crown, 15 gage (0.072 in.) (1.83 mm) galvanized

steel staples. They shall be representative of the product. Each staple shall be used but once. Actual size and details of the staple used shall be recorded.

14.3 Screws used shall be standard 2½-in. (63 mm) No. 10-gage flathead steel wood screws as described in American National Standard for Slotted and Recessed Head Wood Screws (ANSI B18.6.1). Each screw shall be used only once. The screws shall be selected to be representative of the type chosen for test.

15. Sampling

15.1 Tests shall be made using clear, straight-grained representative material. The two pieces of wood used for test (cleat and prism) shall be of end- or side-matched flatsawn material. Whenever possible, the sampling shall be on a statistical basis, and the tests shall be sufficient in number to permit a statistical analysis.

NOTE 5—The precision required and thus the manner of sampling and the number of tests will depend upon the specific objective of the investigation. No general criteria, therefore, can be established. However, experience has indicated that at least five specimens per variable are required as a minimum to give generally acceptable results. A larger number is desirable.

16. Test Specimen

16.1 The size of the specimen that receives the point of the fastener (prism) shall be 2 in. (51 mm) thick, 2 in. (51 mm) wide, and 12 in. (300 mm) long. The size of the specimen through which the fastener is driven (cleat) shall be 2½ in. (20 mm) thick, 2 in. (51 mm) wide, and 12 in. (300 mm) long. The actual dimension of each piece shall be determined.

16.2 The test specimen shall be assembled by overlapping the ends of the 2-in. (50 mm) wide cleat and prism members by a distance of 4 in. (100 mm), thus forming a test specimen with a total length of 20 in. (500 mm). The test fastener shall be inserted at the center of the width of the cleat and the prism and 2 in. (50 mm) from the overlapping end of each. The prism shall be oriented to permit the insertion of the test fastener into a tangential face. A bolt hole ¾ in. (19 mm) in diameter shall be bored at the center of the width and 2 in. (50 mm) from each end of the specimen to accommodate the loading fixtures.

16.3 When testing with a nail, the top of the nailhead shall be driven flush with the surface. The nail shall be driven as nearly perpendicular to the specimen surface as possible.

16.4 When testing with a staple it shall be inserted with an appropriate tool as nearly as possible perpendicular to the specimen surface with the staple crown at a 45° (±10°) angle to the grain direction of the fastened and fastening wood members. When evaluating wood products, if there is no discernible grain direction in the wood product, the staple crown shall be oriented at a 45° (±10°) angle to the length of the fastening member. All staples shall be driven flush or slightly (¼ in.) (1.6 mm) countersunk. Collated staples shall not be cleaned.

16.5 When testing with a screw, the screw shall be inserted with a screw driver through prebored lead holes, which are as nearly perpendicular to the specimen surface as possible. The lead hole in the cleat shall equal the shank diameter of the screw for hardwoods and 90 % of the shank diameter for

softwoods. The lead hole in the prism shall have a diameter of 90 % of the root diameter for hardwoods and 70 % of the root diameter for softwoods and shall be 1½ in. (41 mm) deep. The top of the lead hole in the cleat shall be countersunk and the top of the screw inserted flush with the surface.

17. Conditioning

17.1 The material shall be conditioned in accordance with Section 9.

18. Procedure

18.1 As quickly as possible after assembly, but in all cases within 1 h, test each specimen by tensile loading in a testing machine of suitable capacity. Fig. 2 and Fig. 3 show a nail specimen ready for test. Use the same procedure for evaluating the lateral resistance of staples and screws. The end fixtures shall be such as to provide freedom of alignment. Since the load applied to the specimen is eccentric, use an alignment support such as the roller bearing shown. Fig. 2 and Fig. 3 illustrate one method of measuring the differential movement between the two members under load by means of a dial gage. Other methods may be used, including automatic recording. Measure the movement to the nearest 0.001 in. (0.025 mm). Obtain simultaneous values of differential movement and load at movements of 0.01, 0.015, 0.05, 0.1, 0.2, and 0.3 in. (0.25, 0.38, 1.27, 2.54, 5.08, and 7.62 mm), and at maximum load. Record the first drop in load.

18.2 *Speed of Testing*—Apply the load in accordance with 10.4.

18.3 *Weight and Moisture Content*—Weigh the two wood members of each specimen before assembly and before the



FIG. 2 Assembly for Lateral Resistance Test of Nails, Staples, or Screws

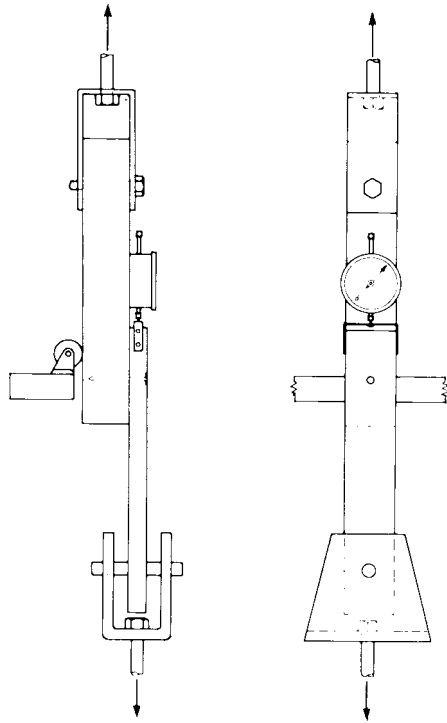

NOTE 1—Slightly different arrangements for measurement of deformations are shown in Figs. 2 and 3.

FIG. 3 Diagram of Assembly for Lateral Resistance Test of Nails, Staples, or Screws

loading holes are drilled, and after the test cut a moisture section approximately 1 in. (25 mm) in length from the body of each member. Determine the specific gravity and moisture content of each in accordance with Methods D 143.

19. Report

19.1 The report shall include the following:

19.1.1 Simultaneous values of load and differential movement at deformations of 0.01, 0.015, 0.05, 0.1, 0.2 and 0.3 in. (0.25, 0.38, 1.27, 2.54, 5.08, and 7.62 mm), and at maximum load.

19.1.2 Typing of fastening tested,

19.1.3 Size of the specimen,

19.1.4 Species of wood used,

19.1.5 Average moisture content and specific gravity, and

19.1.6 Any other special details that may have a bearing on the results.

20. Precision and Bias

20.1 The precision and bias of this test method have not yet been determined.

TESTING BOLTED AND TIMBER CONNECTOR JOINTS

21. Scope

21.1 This test method provides a suitable procedure for evaluating the strength and rigidity of timber joints fastened with bolts or with metal connectors which usually also require bolts to form the joint. The test serves as a basis for developing

design criteria and for determining the effect of various factors on the strength and efficiency of the joint.

22. Summary of Test Method

22.1 Specimens consisting of three-member or two-member wood joints fastened with bolts or bolts and timber connectors are evaluated for their capacity to resist compressive or tensile forces applied at a uniform rate of deformation with a suitable testing machine. The deformation of the joint at various intervals of loading is measured. Supplementary physical properties of the wood members are also determined.

23. Significance and Use

23.1 The joint may be the weakest link in timber construction. While the strength of a metal bolt or connector can be determined on the one hand, and the strength properties of a particular grade and species of wood on the other, only by testing a complete joint can their performance in combination be fully evaluated. Such variables as member thickness, member width, end and edge margins, type of fastener and number of units, spacing between fastener units, moisture content of wood, preservative or fire-retardant treatment of the wood, and species of wood, to mention a few, may affect joint behavior. In order to compile accurate design criteria for established bolt and connector types as well as for those under development, the effect of these variables on joint strength must be known. The tests described herein will permit obtaining data on the strength and rigidity of timber joints under the influence of any or all of the above mentioned factors.

24. Apparatus

24.1 *Testing Machine*—Any suitable testing machine that is capable of operation at a constant rate of motion of the movable head and has an accuracy of $\pm 1\%$ when calibrated in accordance with Practices E 4.

24.2 *Spherical Bearing Block*, for compressive loading of specimens.

24.3 *Grips*—Gripping devices capable of attaching the specimen between the moving heads of the testing machine in such a way as to ensure true axial loads, required for tensile loading of specimens.

24.4 *Deformation Gage*—At least two dial gages with a least reading of 0.001 in. (0.025 mm) or other suitable device for measuring deformation between joint members under load.

25. Sampling

25.1 Sampling should provide for selection of representative test material on an objective and unbiased basis. This principle should apply as well to selection of bolts and connectors as to the wood or wood-base materials to be used. Materials tested for the purpose of getting reliable general averages and variation applying broadly to wood and wood-base materials should be selected at random by a technique that permits correct proportionment to expected density and other physical properties that may influence test results. Sampling required for more limited experiments, as for defining relationships or examining causes and effects, may be accordingly more limited, but should be appropriate to the objectives of the testing program and by unbiased procedures.

25.2 Under all circumstances, tests should be sufficiently extensive to provide reliable results. Where analysis by statistical procedures is contemplated, experience and sometimes advance estimates can be used to establish the scope of testing and type of sampling needed to achieve the expected reliability.

NOTE 6—The precision required, and thus the manner of sampling and number of tests, will depend upon specific objectives. No specific criteria therefore can be established. General experience indicates that the coefficient of variation from tests of fasteners ranges from about 15 to 30 %. When such is the case, precision of 5 to 10 %, with 95 % confidence (an often accepted general measure of reliability for testing wood) cannot be achieved without making a large number of tests. The present recommendation is to make 5 to 10 replications for each variable as a minimum requirement. A larger number of observations may be desirable.

26. Specimens and Tests

26.1 *General*—Wood members shall be selected, and the fasteners positioned in them, in such a way that the results are not affected by knots, cross grain, or other natural or manufacturing characteristics. Frequently, this will necessitate selecting members which are essentially clear and straight grained.

26.2 *Joints Containing Bolts Only:*

26.2.1 Tests shall be made on three-member joints as shown in Fig. 4 and Fig. 5 except where specific data on two-member joints are being sought. The width, length, and thickness of the wood members shall be selected with due regard to the edge and end distances required.

26.2.2 For joints involving metal or other side members, the thickness should be that anticipated in service. For all-wood joints, the thickness of each side member should be at least one half of the thickness of the center member and width and length of all members should be selected with regard to the edge and end distances required for a specific application.

26.2.3 Bolt-hole diameters shall be between $\frac{1}{32}$ and $\frac{1}{16}$ in. (0.8 and 1.6 mm) larger than the bolt diameters (Note 7) and holes shall be carefully bored perpendicular to the surface, so

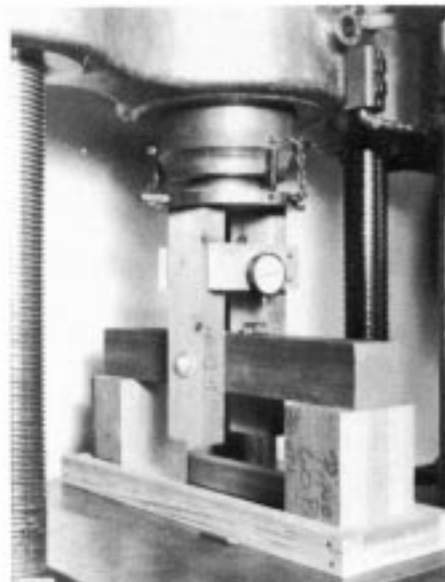

FIG. 5 Assembly for Testing Bolted or Connected Joint Perpendicular to Grain in Compression

that the surface of the hole is smooth and uniform to assure good bearing of the bolt.

NOTE 7—It is suggested that the excess of hole diameter over bolt diameter be $\frac{1}{32}$ in. (0.8 mm) for bolts $\frac{1}{2}$ in. (13 mm) or less in diameter, and $\frac{1}{16}$ in. (1.6 mm) for bolts of larger diameter, provided other bolt-hole diameters are not specified.

26.2.4 Accurate centering of holes is required where a specimen contains two or more bolts. A heavy round washer conforming to Federal Specification FF-W-92 for Washers, Metal, Flat (Plain), and hereafter referred to as a standard washer, shall be placed between the wood side member and the bolt head, and between the wood side member and the nut. Abutting faces of joint members shall be brought into normally installed contact; the nut shall then be backed off and retightened to “finger tightness.”

26.3 *Joints Containing Metal Connectors:*

26.3.1 Tests shall be made on three-member joints except where specific data on two-member joints are being sought. The width, length, and thickness of the wood members should be selected with regard to the edge and end distances required and the net cross section remaining after the metal connectors are in place.

NOTE 8—In some cases the influence of member dimensions will be the parameter being studied. Otherwise, the size of the specimen will depend on the size and type of connector, and specific dimensions cannot be given to cover all cases. For joints involving metal or other side members, the thickness should be that anticipated in service. As a general guide, in the case of all-wood joints, in three-member joints the thickness of each side member should be at least one half of the thickness of the center member. As an example, in joint tests parallel to the grain under compressive loading, split-ring connectors 2½ and 4 in. (63 and 100 mm) in diameter have been used with specimens 3⅞ and 5½ in. (92 and 140 mm) wide, respectively. The thickness of the center member for the 2½-in. connector varied from 2 to 3 in. (51 to 76 mm), and the thickness of the side members from 1 to 1½ in. (25 to 38 mm). The thicknesses of the center and side members for the 4-in. connector were 3 and 1½ in., respectively.

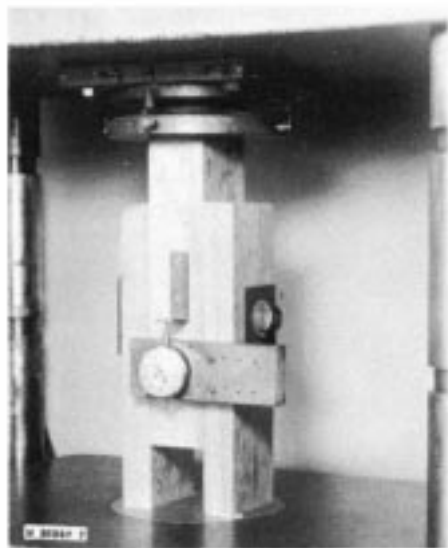

FIG. 4 Assembly for Testing Bolted or Connected Joint Parallel to Grain in Compression

The length of the members for the 2½-in. connector was 13 in. (330 mm), with the side member overlapping the center member by 8 in. (200 mm). The bolt and connectors were placed in the center of the overlapped length. For the 4-in. connector, the side and center members were 17 in. (430 mm) long and were overlapped by 11 in. (280 mm). Under tension loading, specimen lengths and end distances would be greater consistent with the variables being investigated.

26.3.2 Bolt-hole diameters shall be between ⅓₂ and ⅓₁₆ in. (0.8 and 1.6 mm) larger than the bolt diameters, and when using proprietary connectors the groove and hole sizes recommended by the manufacturers should be adhered to, provided other sizes are not to be investigated.

26.3.3 Accurate centering of holes and grooves is required where a specimen contains two or more connector units. A standard washer shall be placed between the wood side member and the bolt head and between the wood side member and the nut. Nuts shall be “finger tight” only. Abutting faces of joint members shall be brought into normally installed contact; the nut shall then be backed off and retightened to “finger tightness.”

26.4 *Both Types of Joints:*

26.4.1 Primary tests shall be made on joints loaded (a) parallel to the grain of the wood and (b) perpendicular to the grain of the wood, with the direction of grain (b-1) of the center member parallel and of the side members perpendicular to the direction of the load or (b-2) of the center member perpendicular and the side members parallel to the direction of the load. These tests may be made by applying compressive or tensile loads as required.

26.4.2 Additional primary tests, as needed, shall be made for the purposes outlined in 26.4.2.1-26.4.2.8. In such tests, a suitable method of matching the material in corresponding members shall be used to prevent masking of differences in results by reason of differences in specific gravity, rate of growth, or other factors. Additional tests are as follows:

26.4.2.1 To establish the effect of bearing area, and length to diameter (L/d) relationship in bolted joints,

26.4.2.2 To determine the effect of angle of load to grain of the wood.

26.4.2.3 To establish minimum end distances required for each size and type of connecting device and the effect of variations in end distance.

26.4.2.4 To determine the minimum thicknesses of lumber that can be used with each connecting device, and the effect of variations in thickness,

26.4.2.5 To establish the optimum spacing between multiple bolts or connectors both parallel and perpendicular to the grain and the effects of variation in spacing,

26.4.2.6 To establish minimum edge distance and the effects of variations in edge distance,

26.4.2.7 To determine the effect of moisture content of wood, and

26.4.2.8 To evaluate any other factor which may affect the performance of the joint.

NOTE 9—The properties of the metal employed in the bolts and connectors are also factors affecting the joint strength and behavior. Data on the properties of the bolts and connectors should, whenever possible, be included in the report.

26.4.3 At least five tests, and preferably ten, shall be made

for evaluating each of the variables to be included. See Note 6 for guidance in this respect.

27. Conditioning

27.1 Except for special tests evaluating the effect of moisture content of the wood on the strength of the joints, the tests shall be made with seasoned wood. Specimens, whether kiln dried, air dried, or as received from manufacturer, preferably should be stored before testing in a room having a controlled temperature of $20 \pm 3^\circ\text{C}$ ($68 \pm 6^\circ\text{F}$) and a controlled relative humidity of $65 \pm 3\%$ for a period sufficiently long to bring them to approximate equilibrium. For most species of wood, exposure to these conditions will result in a moisture content of approximately 12 %.

27.2 For special tests involving drier, unseasoned, or partially seasoned wood components, care shall be taken to maintain the desired moisture content prior to and during testing.

28. Procedure

28.1 *General*—Test the joints as soon after assembly as possible, preferably within 1 h, provided the performance of delayed tests is not required.

28.2 *Test Setup:*

28.2.1 The method of testing a joint parallel to the grain during compressive loading is shown in Fig. 4. Use a spherical bearing block in applying the load. Measure the deformation and slip at successive load increments using dial gages accurate to 0.001 in. (0.025 mm) or other suitable device.

28.2.2 The method of conducting a joint test perpendicular to grain with compressive loading is shown in Fig. 5. Maintain a clear distance between the supports of at least three times the depth of the transverse member. Make provision for measurement of deformation.

28.2.3 Joints can also be tested in tension and in many cases this will be equally or more representative of behavior in service. An adequate design of the ends of the members at which the tensile loads are applied is required to ensure failure in the test joint rather than in the gripping device. Dial gages with a least reading of 0.001 in. (0.02 mm) or other equivalent devices are required for measuring the deformation.

NOTE 10—Since the load applied to a two-member specimen will be eccentric, it is suggested that an alignment support similar to the roller bearing of Fig. 3 be used.

28.3 *Deformation Measurement*—Measure the deformation of the joint from the beginning of the application of the load and take readings of the deformation at sufficiently frequent load intervals to permit establishment of an accurate load-deformation curve. Observe the general behavior of the joint under load and record. Record the first relaxation of the load indicated on the testing machine scale, the kind of failure, and similar details. In a connector joint, the load associated with the first relaxation of load is commonly associated with the shear of the core within the connector. Continue the test until the ultimate load or a total deformation of 0.60 in. (15 mm) is reached. Record the maximum load.

28.4 *Speed of Testing*—Conduct the test to achieve maximum load in about 10 min, but reach maximum load in not less than 5 or more than 20 min. A rate of motion of the movable



crosshead of 0.035 in. (0.9 mm)/min \pm 50 % will usually permit reaching maximum load, in the prescribed time. Record the speed used.

NOTE 11—The crosshead speed shall mean the free-running, or no-load, crosshead speed for testing machines of the mechanical-drive type, and the loaded crosshead speed for testing machines of the hydraulic-loading type.

28.5 *Minor Tests*—Determine the specific gravity and moisture content of each wood member of each joint tested. It may also be desirable in some cases to determine the compressive strength parallel to grain of the wood members. Procedures for determining these properties are given in the following ASTM methods:

28.5.1 Test Methods D 2395.

28.5.2 Test Methods D 2016.

28.5.3 Methods D 143 (compression parallel to grain).

29. Report

29.1 The report shall include the following:

29.1.1 Data on load - deformation relationships,

29.1.2 Description of the general behavior of the joint under load,

29.1.3 Description of the joint including the materials used,

29.1.4 Member dimensions, including measurements of end and edge distances, member thickness, and bolt-hole and connector-groove dimensions where applicable,

29.1.5 Details of loading procedure,

29.1.6 Number of tests,

29.1.7 Specific gravity and moisture content of wood members at time of fabrication and at time of test for each specimen, along with species identification,

29.1.8 Compression parallel to grain strength of the wood members if determined, and

29.1.9 Details of any deviations from the prescribed or recommended methods as outlined in the standard.

30. Precision and Bias

30.1 The precision and bias of this test method have not yet been determined.

TENSION TESTS OF PLATE-TYPE CONNECTOR JOINTS

31. Scope

31.1 This test method covers determination of the tensile strength and stiffness characteristics of symmetrical joints in which parallel planar wood members are connected by fasteners of the type commonly known as “truss plates.” This method has been especially designed for determining the tensile properties of joints that connect nominal 2-in. dimension lumber such as those commonly used in light roof truss assemblies. It is recommended that the specified procedure be followed as closely as is practicable and that any deviations be described.

32. Summary of Test Method

32.1 Specimens consisting of two nominal 2-in. (51 mm) parallel planar wood members, connected end to end by two truss plates fastened symmetrically, are evaluated for their

capacity to resist tensile forces applied at a uniform rate of deformation with a suitable testing machine. The slip or deformation of the joint is measured at various intervals of loading and supplementary physical properties of the wood members are determined.

33. Significance and Use

33.1 For design purposes it is necessary to know the load-carrying capacity of the tension joint in the lower chord of a light wood truss. The tests described herein are specifically intended for evaluating this type of tension joint.

33.2 The characteristics of the truss plate with its variety of forms and sizes, the species of wood and its moisture content treatments, or both, all affect joint behavior. The tensile performance of the joint can be evaluated by these test methods. Generally it may be expected that unit values (per tooth or per nail) will vary with the number of teeth per fastener involved, and caution is urged in extending the results from tests of a plate of a given type and size to one of the same type but of different size, unless data are available to justify such extension. It should also be recognized that the net section of the metal plate will become the load-limiting factor after a certain load capacity is attained with the tooth-wood combination.

34. Apparatus

34.1 *Testing Machine*—Any suitable testing machine capable of applying the required loads at the specified rates and having an accuracy of ± 1 % when calibrated in accordance with Practices E 4 may be used.

34.2 *Specimen Grips*—The test specimen shall be suspended by a system ensuring universal movement at both ends. The type of grips used shall be capable of carrying the test joints to failure without introducing bending in the joint.

34.3 *Instrumentation*:

34.3.1 The joint-deformation measuring instrumentation shall be arranged so as to measure the separation of the wood members upon application of the tensile load. The instrumentation shall be of such accuracy as to permit plotting a meaningful load-deformation curve. In general, this can be achieved with instruments allowing a least reading of 0.001 in. (0.02 mm). For the more rigid types of joints, it may be necessary to use instruments allowing a least reading of 0.001 in.

34.3.2 Other suitable means, such as photographic methods, may be used, provided their accuracy is at least equal to the above. A satisfactory arrangement for this type of test is shown in Fig. 6.

35. Sampling

35.1 Sampling shall be done in accordance with Section 7, except that where the tests are made to establish suitability of the connectors for use with particular species and grades of wood, the materials shall represent, insofar as possible, the variations to be expected.

36. Test Specimens

36.1 A specimen joint shall be composed of nominal 2-in. lumber connected by two identical connector plates placed

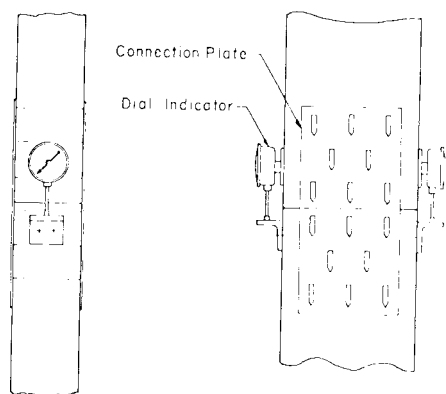

FIG. 6 Typical Arrangement for Tension Tests of Plate-Type Joints

symmetrically about the joint. The joints shall be formed so as to align the axes of the wood members with the ends of the wood members tightly abutted before the plates are attached. The specimen joint shall be formed in the same manner as is contemplated in use (same number and size of nails, same embedment of teeth, etc.).

36.2 The lengths of the connected wood members shall be determined according to the type of gripping apparatus used. In no case shall the gripping apparatus impinge upon the connection or the deformation-measuring apparatus.

37. Conditioning

NOTE 12—It is recommended that the distance between the end of the plate and the gripping apparatus be at least 6 in. (152 mm).

37.1 Except for special tests to determine the effect of moisture content of the wood, the tests shall be made on material conditioned in accordance with Section 9.

38. Procedure

38.1 *Speed of Testing*—Use the testing speed described in 28.4.

38.2 Measure the slip of the joint from the beginning of the application of the load, and take readings of this joint separation at sufficiently frequent intervals to permit establishment of an accurate load-deformation curve based on the averages of readings taken with the two deformation-measuring devices.

38.3 Continue the test until maximum load has been obtained or a total joint deformation of 0.60 in. (15.24 mm) has been obtained.

38.4 *Minor Tests*—Immediately after testing, take a specimen approximately 1 in. (25 mm) thick along the grain from each piece between the connector plate and the grip. The specimen shall be taken as close to the connector plate as possible and it shall be free of all defects such as knots, wane, and non-typical growth. From this specimen determine the moisture content and the specific gravity (based on oven-dry weight and oven-dry volumen) in accordance with the following ASTM test methods:

- 38.4.1 Test Methods D 2016, and
- 38.4.2 Test Methods D 2395.

39. Report

39.1 The report shall include the following:

- 39.1.1 Complete description and dimensions of joining system, including lumber edge and end distances, connector plates, adhesives, nails, etc.,
- 39.1.2 Deformation rate (in. (mm)/min),
- 39.1.3 Elapsed time of test,
- 39.1.4 Maximum load,
- 39.1.5 Type of failure,
- 39.1.6 Plot of load versus joint separation,
- 39.1.7 Wood member sizes, species, and grades,
- 39.1.8 Moisture content at time of joint fabrication and at a time of test,
- 39.1.9 Specific gravity as determined in 38.4.2,
- 39.1.10 Specimen age at time of test, and
- 39.1.11 Data, laboratory, and technician.

40. Precision and Bias

40.1 The precision and bias of this test method have not yet been determined.

JOIST HANGER TESTS

41. Scope and Application

41.1 This test method provides a procedure for evaluating the vertical load-carrying capacity, torsional moment capacity, and deflection characteristics of joist hangers and similar devices used to connect wood joists to headers of wood or other materials.

41.2 The tests serve as a basis for developing design criteria for various hanger devices used with wood joists, and provide standard procedures for evaluating their performance with respect to specific requirements.

42. Summary of Test Method

42.1 *Vertical Load Capacity*—Specimens consisting of a length of joist suspended by hanger devices between two supporting headers are subjected to a vertical load by a suitable testing machine, while the vertical slip of the suspended piece is measured and recorded to provide load-slip data.

42.2 *Torsional Moment Capacity*—Specimens consisting of a length of joist suspended by hanger devices between two supporting headers are subjected to a torsional moment-producing load by a suitable testing machine, while the movement of the joist with respect to the headers is measured and recorded to provide data for calculating angular rotation and load-slip relationships.

43. Significance and Use

43.1 Joist hangers and similar devices are used to transfer vertical loads from a joist to a connecting header in building construction. This is a critical connection, the performance of which is influenced by a number of variables such as the properties of the hanger itself, the joist material, the header material, the method of fastening the device to the joist and to the header. As with many fastening devices, a knowledge of the qualities of individual components is insufficient to indicate the performance of the assembled connection consisting of the hanger, the joist, and the header functioning as a unit. The tests described herein provide for uniformity in evaluating the performance of such units.

44. Apparatus

44.1 *Testing Machine*—A suitable testing machine that is capable of operation at a constant rate of motion of the movable head and has an accuracy of $\pm 1\%$ when calibrated in accordance with Practices E 4.

44.2 *Deformation Gage*—Two dial gages for the vertical load test and four dial gages for the torsional test with a least reading of 0.001 in. (0.02 mm), or other suitable devices for measuring deformation between joist and headers under load.

45. Sampling

45.1 Sampling shall be done in accordance with Section 7. Except where the tests are made to establish suitability of the hanger devices for use with particular grades, dimensions, and species of wood, the materials shall represent insofar as possible the variations to be expected in practice.

46. Test Specimens

46.1 Vertical Load Capacity:

46.1.1 A test specimen shall consist of an assembly of a joist affixed in accordance with the recommendations of the manufacturer between two headers by the hanger devices to be evaluated, as shown in Fig. 7.

46.1.2 Joist sections shall have a length of 10 in. (254 mm) plus twice the depth of the joist, providing that the minimum length shall be not less than 18 in. (467 mm). Headers shall have a minimum length of 14 in. (350 mm). A clearance of $\frac{1}{8}$ in. (3 mm) shall be provided between each joist end and adjacent header. During test this clearance shall be maintained and header rotation toward the joist shall be restrained. This can be accomplished by blocking between adjacent headers at the ends on both sides of the joist, with solid blocking or any suitable clamping method which does not interfere with the performance of the hanger device being loaded.

46.1.3 Where a hanger device is of a design that is not adaptable to such a test assembly, necessary departures may be made provided the altered assembly will perform the identical function, and provided that such departures are reported in detail.

46.2 Torsional Moment Capacity:

46.2.1 A specimen shall consist of an assembly of a joist affixed in accordance with the recommendations of the manufacturer between two headers by the hanger devices to be evaluated, as shown in Fig. 8. Assemble specimen joist and headers with their top edges in the same plane.

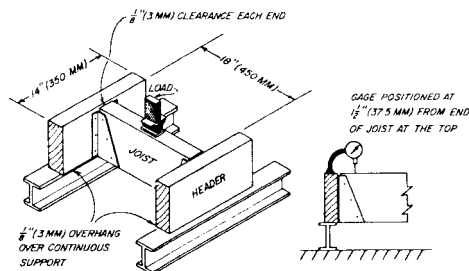

NOTE 1—Header restraint against rotation toward the joist is to be provided in accordance with text.

FIG. 7 Vertical Load Test Assembly

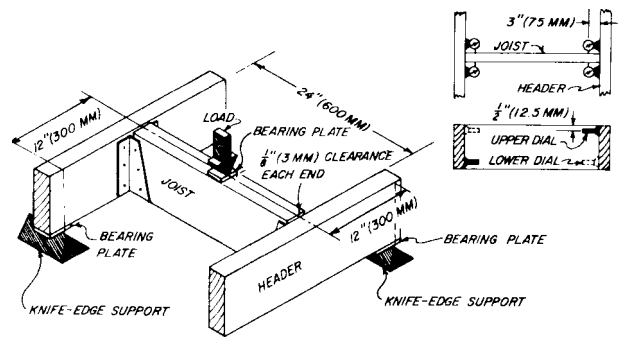

FIG. 8 Torsional Moment Test Assembly

46.2.2 Headers shall be sufficiently long to accommodate adequate bearing area for a knife edge support applied at 12 in. (300 mm) from the centre line of the hung joist. The hung joist section shall be 24 in. (600 mm) long. A clearance of $\frac{1}{8}$ in. (3 mm) shall be provided between each joist end and adjacent header.

46.2.3 Where a hanger device is of a design that is not adaptable to such a test assembly, necessary departures may be made provided the altered assembly will perform the identical function, and provided that such departures are reported in detail.

47. Conditioning

47.1 Except for special tests to determine the effect of moisture changes of the wood joist on hanger performance, the tests shall be made on specimens conditioned in accordance with Section 27.

48. Procedure

48.1 Vertical Load Capacity:

48.1.1 When inserted in the testing machine, a specimen shall have the top of the joist and headers in the same plane. It is desirable to provide a continuous support under each header, so positioned as to result in an overhang of $\frac{1}{8}$ in. (3 mm) at the inside edges.

48.1.2 Vertical movement of the joist with respect to the header at each end measure at a point 1.5 in. (37.5 mm) from the end of each joist at the top by means of the dial gages referred to above. Record the slip to the nearest 0.001 in. (0.02 mm) at a sufficient number of load levels to permit establishment of an accurate load-deformation curve based on the averages of simultaneous readings taken with the two deformation measuring devices.

48.1.3 Apply the load at the centre span of the joist at a uniform rate of descent of the loading head of the testing machine of 0.035 in. (0.9 mm)/min $\pm 50\%$ until ultimate load is reached. Bearing area under the applied load should be sufficient only to prevent undue crushing of the joist at the load point, but the length of bearing must not exceed half the joist length in any case.

NOTE 13—The crosshead speed shall mean the free running, or no-load, crosshead speed for testing machines of the mechanical-drive type, and the loaded crosshead speed for testing machines of the hydraulic-loading type.

48.1.4 Use a spherical bearing block between head and specimen to equalize the load at each of the joist ends.



48.2 Torsional Moment Capacity:

48.2.1 Support the test specimen symmetrically at the bottom of the headers by knife edge supports located 12 in. (300 mm) from the centre line of the joist and applied load, as shown in Fig. 8. Both support points shall be at the same elevation. Apply the load at the centre span of the joist, as in 48.1.3. Bearing area under the applied load should be sufficient only to prevent undue crushing of the joist at the load point, but the length of bearing must not exceed one half the joist length in any case.

48.2.2 Measure rotational deflection of each end of the joist, with respect to the headers. The dial gages or other suitable devices having at least reading of 0.001 in. (0.02 mm) shall be supported by the headers and be placed to measure movement of the top and bottom edges of each end of the joist at 3 in. (75 mm) from the ends and at ½ in. (13 mm) from the top and bottom edges of the joist as shown in Fig. 8. Measurements are to be taken directly from the joist, not the hanger device. Where the hanger does not permit readings to be taken at 3 in. (75 mm) from the joist end, take the readings at a point in excess of 3 in. (75 mm) but just to clear the hanger device with all gages at equal distances from the joist ends.

48.2.3 Take deflections and their load readings at the necessary increments such that incremental readings do not exceed 0.025 in. (0.65 mm). Apply the load at a uniform rate with machine head speed approximately 0.01 in. (0.25 mm)/min. The rate may be decreased to accommodate the reading of deflections within the 0.025 in. (0.65 mm) increments. Record deflections to the nearest 0.001 in. (0.02 mm) and record loads to the nearest 1.0 lb (0.45 kg).

NOTE 14—The crosshead speed shall mean the free-running, or no-load, crosshead speed for testing machines of the mechanical-drive type, and the loaded crosshead speed for testing machines of the hydraulic-loading type.

48.2.4 Add the joist deflection at the top and bottom edges of the same end to obtain the total displacement of the joist end with respect to the header, from which the angular rotation of the joist end may be calculated.

48.2.5 Angular rotation of the joist end in radians, for relatively small angles, equals the total displacement divided by the vertical distance between dial gages. Multiplying radians by $180/\pi$ will convert to degrees.

48.2.6 The torsional moment applied to each end of the joist is computed thus: machine load (lb) (kg) divided by 2 and then multiplied by 24 in. (600 mm).

49. Minor Tests

49.1 Determine the specific gravity and moisture content of the joists and headers (if of wood) in accordance with procedures of the following test methods: Test Methods D 2016 and D 2395.

50. Report

50.1 The test report shall contain the following:

50.1.1 Detailed description of the hangers tested including any fasteners that are required,

50.1.2 A detailed description of the specimen(s) including actual dimensions of joists and headers, species, grade, and natural characteristics,

50.1.3 Data on load-slip or load-deformation relationships, angular rotation, and maximum loads observed,

50.1.4 Type of failure and description of the general behavior of the specimen.

50.1.5 Number of replications,

50.1.6 Loading procedure details,

50.1.7 Specific gravity and moisture content of the joists and headers (if of wood), and

50.1.8 Details of any deviations from the prescribed methods as outlined in this standard.

51. Precision and Bias

51.1 The precision and bias of this test method have not yet been determined.

52. Keywords

52.1 fasteners; mechanical fasteners; nails; screws; wood-base materials

ASTM International takes no position respecting the validity of any patent rights asserted in connection with any item mentioned in this standard. Users of this standard are expressly advised that determination of the validity of any such patent rights, and the risk of infringement of such rights, are entirely their own responsibility.

This standard is subject to revision at any time by the responsible technical committee and must be reviewed every five years and if not revised, either reapproved or withdrawn. Your comments are invited either for revision of this standard or for additional standards and should be addressed to ASTM International Headquarters. Your comments will receive careful consideration at a meeting of the responsible technical committee, which you may attend. If you feel that your comments have not received a fair hearing you should make your views known to the ASTM Committee on Standards, at the address shown below.

This standard is copyrighted by ASTM International, 100 Barr Harbor Drive, PO Box C700, West Conshohocken, PA 19428-2959, United States. Individual reprints (single or multiple copies) of this standard may be obtained by contacting ASTM at the above address or at 610-832-9585 (phone), 610-832-9555 (fax), or service@astm.org (e-mail); or through the ASTM website (www.astm.org).