



Designation: D 198 – 99

## Standard Test Methods of Static Tests of Lumber in Structural Sizes<sup>1</sup>

This standard is issued under the fixed designation D 198; the number immediately following the designation indicates the year of original adoption or, in the case of revision, the year of last revision. A number in parentheses indicates the year of last reapproval. A superscript epsilon ( $\epsilon$ ) indicates an editorial change since the last revision or reapproval.

### INTRODUCTION

Numerous evaluations of structural members of solid sawn lumber have been conducted in accordance with ASTM Test Methods D 198 – 27. While the importance of continued use of a satisfactory standard should not be underestimated, the original standard (1927) was designed primarily for sawn material such as solid wood bridge stringers and joists. With the advent of laminated timbers, wood-plywood composite members, and even reinforced and prestressed timbers, a procedure adaptable to a wider variety of wood structural members is required.

The present standard expands the original standard to permit its application to wood members of all types. It provides methods of evaluation under loadings other than flexure in recognition of the increasing need for improved knowledge of properties under such loadings as tension to reflect the increasing use of dimensions lumber in the lower chords of trusses. The standard establishes practices that will permit correlation of results from different sources through the use of a uniform procedure. Provision is made for varying the procedure to take account of special problems.

### 1. Scope

1.1 These test methods cover the evaluation of lumber in structural size by various testing procedures.

1.2 The test methods appear in the following order:

	Sections
Flexure	4 to 11
Compression (Short Column)	12 to 19
Compression (Long Member)	20 to 27
Tension	28 to 35
Torsion	36 to 43
Shear Modulus	44 to 51

1.3 Notations and symbols relating to the various testing procedures are given in Table X1.1.

1.4 *This standard does not purport to address all of the safety concerns, if any, associated with its use. It is the responsibility of the user of this standard to establish appropriate safety and health practices and determine the applicability of regulatory limitations prior to use.*

### 2. Referenced Documents

#### 2.1 ASTM Standards:

D 9 Terminology Relating to Wood<sup>2</sup>

<sup>1</sup> These methods are under the jurisdiction of ASTM Committee D-7 on Wood and are the direct responsibility of Subcommittee D07.01 on Fundamental Test Methods and Properties.

Current edition approved Dec. 10, 1999. Published April 2000. Originally published as D 198 – 24. Last previous edition D 198 – 98.

<sup>2</sup> *Annual Book of ASTM Standards*, Vol 04.10.

D 1165 Nomenclature of Domestic Hardwoods and Softwoods<sup>2</sup>

D 2395 Test Methods for Specific Gravity of Wood and Wood-Base Materials<sup>2</sup>

D 4442 Test Methods for Direct Moisture Content Measurement of Wood and Wood-Base Materials<sup>2</sup>

E 4 Practices for Force Verification of Testing Machines<sup>3</sup>

E 6 Terminology Relating to Methods of Mechanical Testing<sup>3</sup>

E 83 Practice for Verification and Classification of Extensometers<sup>3</sup>

### 3. Terminology

3.1 *Definitions*—See Terminology E 6, Terminology D 9, and Nomenclature D 1165. A few related terms not covered in these standards are as follows:

3.1.1 *span*—the total distance between reactions on which a beam is supported to accommodate a transverse load (Fig. 1).

3.1.2 *shear span*—two times the distance between a reaction and the nearest load point for a symmetrically loaded beam (Fig. 1).

3.1.3 *depth of beam*—that dimension of the beam which is perpendicular to the span and parallel to the direction in which the load is applied (Fig. 1).

3.1.4 *span-depth ratio*—the numerical ratio of total span divided by beam depth.

3.1.5 *shear span-depth ratio*—the numerical ratio of shear span divided by beam depth.

<sup>3</sup> *Annual Book of ASTM Standards*, Vol 03.01.

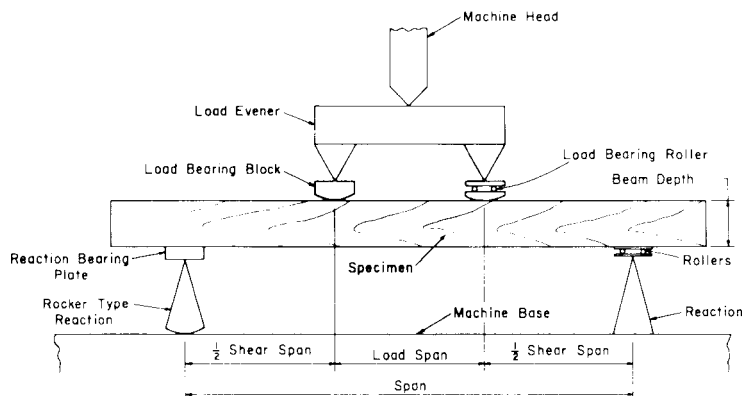

FIG. 1 Flexure Method

3.1.6 *structural wood beam*—solid wood, laminated wood, or composite structural members for which strength or stiffness, or both are primary criteria for the intended application and which usually are used in full length and in cross-sectional sizes greater than nominal 2 by 2 in. (38 by 38 mm).

3.1.7 *composite wood beam*—a laminar construction comprising a combination of wood and other simple or complex materials assembled and intimately fixed in relation to each other so as to use the properties of each to attain specific structural advantage for the whole assembly.

## FLEXURE

### 4. Scope

4.1 This test method covers the determination of the flexural properties of structural beams made of solid or laminated wood, or of composite constructions. This test method is intended primarily for beams of rectangular cross section but is also applicable to beams of round and irregular shapes, such as round posts, I-beams, or other special sections.

### 5. Summary of Test Method

5.1 The structural member, usually a straight or a slightly cambered beam of rectangular cross section, is subjected to a bending moment by supporting it near its ends, at locations called reactions, and applying transverse loads symmetrically imposed between these reactions. The beam is deflected at a prescribed rate, and coordinate observations of loads and deflections are made until rupture occurs.

### 6. Significance and Use

6.1 The flexural properties established by this test method provide:

6.1.1 Data for use in development of grading rules and specifications.

6.1.2 Data for use in development of working stresses for structural members.

6.1.3 Data on the influence of imperfections on mechanical properties of structural members.

6.1.4 Data on strength properties of different species or grades in various structural sizes.

6.1.5 Data for use in checking existing equations or hypotheses relating to the structural behavior of beams.

6.1.6 Data on the effects of chemical or environmental conditions on mechanical properties.

6.1.7 Data on effects of fabrication variables such as depth, taper, notches, or type of end joint in laminations.

6.1.8 Data on relationships between mechanical and physical properties.

6.2 Procedures are described here in sufficient detail to permit duplication in different laboratories so that comparisons of results from different sources will be valid. Special circumstances may require deviation from some details of these procedures. Any variations shall be carefully described in the report (see Section 11).

### 7. Apparatus

7.1 *Testing Machine*—A device that provides (1) a rigid frame to support the specimen yet permit its deflection without restraint, (2) a loading head through which the force is applied without high-stress concentrations in the beam, and (3) a force-measuring device that is calibrated to ensure accuracy in accordance with Practices E 4.

7.2 *Support Apparatus:*

7.2.1 *Reaction Bearing Plates*—The beam shall be supported by metal bearing plates to prevent damage to the beam at the point of contact between beam and reaction support (Fig. 1). The size of the bearing plates may vary with the size and shape of the beam. For rectangular beams as large as 12 in. (305 mm) deep by 6 in. (152 mm) wide, the recommended size of bearing plate is 1/2 in. (13 mm) thick by 6 in. (152 mm) lengthwise and extending entirely across the width of the beam.

7.2.2 *Reaction Bearing Roller*—The bearing plates shall be supported by either rollers and a fixed knife edge reaction or a rocker type-knife edge reaction so that shortening and rotation of the beam about the reaction due to deflection will be unrestricted (Fig. 1).

7.2.3 *Reaction Bearing Alignment*—Provisions shall be made at the reaction to allow for initial twist in the length of the beam. If the bearing surfaces of the beam at its reactions are not parallel, the beam shall be shimmed or the individual bearing plates shall be rotated about an axis parallel to the span to provide full bearing across the width of the specimen (Fig. 2).

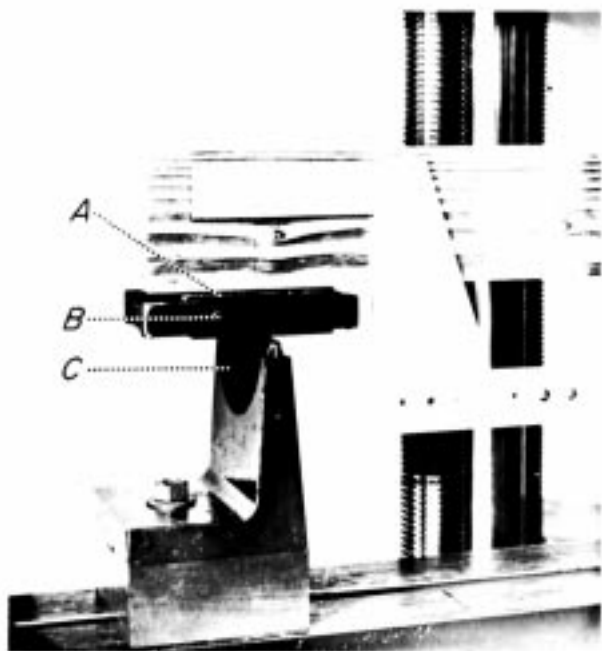

FIG. 2 Example of Bearing Plate, A, Rollers, B, and Reaction-Alignment-Rocker, C, for Small Beams

7.2.4 *Lateral Support*— Specimens that have a depth-to-width ratio of three or greater are subject to lateral instability during loading, thus requiring lateral support. Support shall be provided at least at points located about half-way between the reaction and the load point. Additional supports may be used as required. Each support shall allow vertical movement without frictional restraint but shall restrict lateral deflection (Fig. 3).

7.3 *Load Apparatus:*

7.3.1 *Load Bearing Blocks*—The load shall be applied through bearing blocks (Fig. 1) across the full beam width which are of sufficient thickness to eliminate high-stress concentrations at places of contact between beam and bearing blocks. The loading surface of the blocks shall have a radius of

curvature equal to two to four times the beam depth for a chord length at least equal to the depth of the beam. Load shall be applied to the blocks in such a manner that the blocks may rotate about an axis perpendicular to the span (Fig. 4). Provisions such as rotatable bearings or shims shall be made to ensure full contact between the beam and both loading blocks. Metal bearing plates and rollers shall be used in conjunction with one load bearing block to permit beam deflection without restraint (Fig. 4). The size of these plates and rollers may vary with the size and shape of the beam, the same as for the reaction bearing plates. Beams having circular or irregular cross sections shall have bearing blocks which distribute the load uniformly to the bearing surface and permit, unrestrained deflections.

7.3.2 *Load Points*— The total load on the beam shall be applied equally at two points equidistant from the reactions. The two load points will normally be at a distance from their reaction equal to one third of the span, but for special purposes other distances may be specified.

NOTE 1—One of the objectives of two-point loading is to subject the portion of the beam between load points to a uniform bending moment, free of shear, and with comparatively small loads at the load points. For example, loads applied at one-third span length from reactions would be less than if applied at one-fourth span length from reaction to develop a moment of similar magnitude. When loads are applied at the one-third points the moment distribution of the beam simulates that for loads uniformly distributed across the span to develop a moment of similar magnitude. If loads are applied at the outer one-fourth points of the span, the maximum moment and shear are the same as the maximum moment and shear for the same total load uniformly distributed across the span.

7.4 *Deflection Apparatus:*

7.4.1 *General*—For either apparent or true modulus of elasticity calculations, devices shall be provided by which the deflection of the neutral axis of the beam at the center of the span is measured with respect to either the reaction or between cross sections free of shear deflections.

7.4.2 *Wire Deflectometer*—Deflection may be read directly by means of a wire stretched taut between two nails driven into the neutral axis of the beam directly above the reactions and



FIG. 3 Example of Lateral Support for Long, Deep Beams



**FIG. 4 Example of Curved Loading Block, A, Load-Alignment Rocker, B, Roller-Curved Loading Block, C, Load Evener, D, and Deflection-Measuring Apparatus, E**

extending across a scale attached at the neutral axis of the beam at midspan. Deflections may be read with a telescope or reading glass to magnify the area where the wire crosses the scale. When a reading glass is used, a reflective surface placed adjacent to the scale will help to avoid parallax.

**7.4.3 Yoke Deflectometer**—A satisfactory device commonly used for short, small beams or to measure deflection of the center of the beam with respect to any point along the neutral axis consists of a lightweight U-shaped yoke suspended between nails driven into the beam at its neutral axis and a dial micrometer attached to the center of the yoke with its stem attached to a nail driven into the beam at midspan at the neutral axis. Further modification of this device may be attained by replacing the dial micrometer with a deflection transducer for automatic recording (Fig. 4).

**7.4.4 Accuracy**—The devices shall be such as to permit measurements to the nearest 0.01 in. (0.25 mm) on spans greater than 3 ft. (0.9 m) and 0.001 in. (0.03 mm) on spans less than 3 ft. (0.9 m).

## 8. Test Specimen

**8.1 Material**—The test specimen shall consist of a structural member which may be solid wood, laminated wood, or a composite construction of wood or of wood combined with plastics or metals in sizes that are usually used in structural applications.

**8.2 Identification**—Material or materials of the test specimen shall be identified as fully as possible by including the origin or source of supply, species, and history of drying and conditioning, chemical treatment, fabrication, and other pertinent physical or mechanical details which may affect the strength. Details of this information shall depend on the material or materials in the beam. For example, the solid wooden beams would be identified by the character of the

wood, that is, species, source, etc., whereas composite wooden beams would be identified by the characteristics of the dissimilar materials and their size and location in the beam.

**8.3 Specimen Measurements**—The weight and dimensions as well as moisture content of the specimen shall be accurately determined before test. Weights and dimensions (length and cross section) shall be measured to three significant figures. Sufficient measurements of the cross section shall be made along the length of the beam to describe the width and depth of rectangular specimen and to accurately describe the critical section or sections of nonuniform beams. The physical characteristics of the specimen as described by its density and moisture content may be determined in accordance with Test Methods D 2395 and Test Methods D 4442.

**8.4 Specimen Description**—The inherent imperfections or intentional modifications of the composition of the beam shall be fully described by recording the size and location of such factors as knots, checks, and reinforcements. Size and location of intentional modifications such as placement of laminations, glued joints, and reinforcing steel shall be recorded during the fabrication process. The size and location of imperfections in the interior of any beam must be deduced from those on the surface, especially in the case of large sawn members. A sketch or photographic record shall be made of each face and the ends showing the size, location, and type of growth characteristics, including slope of grain, knots, distribution of sapwood and heartwood, location of pitch pockets, direction of annual rings, and such abstract factors as crook, bow, cup, or twist which might affect the strength of the beam.

**8.5 Rules for Determination of Specimen Length**—The cross-sectional dimensions of solid wood structural beams and composite wooden beams usually have established sizes, depending upon the manufacturing process and intended use, so that no modification of these dimensions is involved. The length, however, will be established by the type of data desired. The span length is determined from knowledge of beam depth, the distance between load points, as well as the type and orientation of material in the beam. The total beam length shall also include an overhang or extension beyond each reaction support so that the beam can accommodate the bearing plates and rollers and will not slip off the reactions during test.

**NOTE 2**—Some evaluations will require simulation of a specific design condition where nonnormal overhang is involved. In such instances the report shall include a complete description of test conditions, including overhang at each support.

**8.5.1** The span length of beams intended primarily for evaluation of shear properties shall be such that the shear span is relatively short. Beams of wood of uniform rectangular cross section having the ratio of  $a/h$  less than five are in this category and provide a high percentage of shear failures.

**NOTE 3**—If approximate values of modulus of rupture  $S_R$  and shear strength  $\tau_m$  are known,  $a/h$  values should be less than  $S_R/4\tau_m$ , assuming that when  $a/h = S_R/4\tau_m$  the beam will fail at the same load in either shear or in extreme outer fibers.

**8.5.2** The span length of beams intended primarily for evaluation of flexural properties shall be such that the shear span is relatively long. Beams of wood of uniform rectangular

cross section having  $a/h$  ratios of from 5:1 to 12:1 are in this category.

NOTE 4—The  $a/h$  values should be somewhat greater than  $S_R/4\tau_m$  so that the beams do not fail in shear but should not be so large that beam deflections cause sizable thrust of reactions and thrust values need to be taken into account. A suggested range of  $a/h$  values is between approximately  $0.5 S_R/\tau_m$  and  $1.2 S_R/\tau_m$ . In this category, shear distortions affect the total deflection, so that flexural properties may be corrected by formulae provided in the appendix.

8.5.3 The span length of beams intended primarily for evaluation of only the deflection of specimen due to bending moment shall be such that the shear span is long. Wood beams of uniform rectangular cross section in this category have  $a/h$  ratios greater than 12:1.

NOTE 5—The shear stresses and distortions are assumed to be small so that they can be neglected; hence the  $a/h$  ratio is suggested to be greater than  $S_R/\tau_m$ .

## 9. Procedure

9.1 *Conditioning*— Unless otherwise indicated in the research program or material specification, condition the test specimen to constant weight so it is in moisture equilibrium under the desired environmental conditions. Approximate moisture contents with moisture meters or measure more accurately by weights of samples in accordance with Test Methods D 4442.

9.2 *Test Setup*—Determine the size of the specimen, the span, and the shear span in accordance with 7.3.2 and 8.5. Locate the beam symmetrically on its supports with load bearing and reaction bearing blocks as described in 7.2 to 7.4. The beams shall be adequately supported laterally in accordance with 7.2.4. Set apparatus for measuring deflections in place (see 7.4). Full contact shall be attained between support bearings, loading blocks, and the beam surface.

9.3 *Speed of Testing*— Conduct the test at a constant rate to achieve maximum load in about 10 min, but maximum load should be reached in not less than 6 min nor more than 20 min. A constant rate of outer strain,  $z$ , of 0.0010 in./in. · min (0.001 mm/mm · min) will usually permit the tests of wood members to be completed in the prescribed time. The rate of motion of the movable head of the test machine corresponding to this suggested rate of strain when two symmetrical concentrated loads are employed may be computed from the following equation:

$$N = Za(3L - 4a)/3h$$

### 9.4 Load-Deflection Curves:

9.4.1 Obtain load-deflection data with apparatus described in 7.4.1. Note the load and deflection at first failure, at the maximum load, and at points of sudden change. Continue loading until complete failure or an arbitrary terminal load has been reached.

9.4.2 If additional deflection apparatus is provided to measure deflection over a second distance,  $l$ , in accordance with 7.4.1, such load-deflection data shall be obtained only up to the proportional limit.

9.5 *Record of Failures*—Describe failures in detail as to type, manner and order of occurrence, and position in beam. Record descriptions of the failures and relate them to drawings

or photographs of the beam referred to in 8.4. Also record notations as the order of their occurrence on such references. Hold the section of the beam containing the failure for examination and reference until analysis of the data has been completed.

## 10. Calculation

10.1 Compute physical and mechanical properties and their appropriate adjustments for the beam in accordance with the relationships in Appendix X2.

## 11. Report

11.1 Report the following information:

11.1.1 Complete identification of the solid wood or composite construction, including species, origin, shape and form, fabrication procedure, type and location of imperfections or reinforcements, and pertinent physical or chemical characteristics relating to the quality of the material,

11.1.2 History of seasoning and conditioning,

11.1.3 Loading conditions to portray the load, support mechanics, lateral supports, if used, and type of equipment,

11.1.4 Deflection apparatus,

11.1.5 Depth and width of the specimen or pertinent cross-sectional dimensions,

11.1.6 Span length and shear span distance,

11.1.7 Rate of load application,

11.1.8 Computed physical and mechanical properties, including specific gravity and moisture content, flexural strength, stress at proportional limit, modulus of elasticity, and a statistical measure of variability of these values,

11.1.9 Data for composite beams include shear and bending moment values and deflections,

11.1.10 Description of failure, and

11.1.11 Details of any deviations from the prescribed or recommended methods as outlined in the standard.

## COMPRESSION PARALLEL TO GRAIN (SHORT COLUMN, NO LATERAL SUPPORT, $l/r < 17$ )

## 12. Scope

12.1 This test method covers the determination of the compressive properties of elements taken from structural members made of solid or laminated wood, or of composite constructions when such an element has a slenderness ratio (length to least radius of gyration) of less than 17. The method is intended primarily for members of rectangular cross section but is also applicable to irregularly shaped studs, braces, chords, round posts, or special sections.

## 13. Summary of Test Method

13.1 The structural member is subjected to a force uniformly distributed on the contact surface of the specimen in a direction generally parallel to the longitudinal axis of the wood fibers, and the force generally is uniformly distributed throughout the specimen during loading to failure without flexure along its length.

## 14. Significance and Use

14.1 The compressive properties obtained by axial compression will provide information similar to that stipulated for

flexural properties in Section 6.

14.2 The compressive properties parallel to grain include modulus of elasticity, stress at proportional limit, compressive strength, and strain data beyond proportional limit.

## 15. Apparatus

15.1 *Testing Machine*— Any device having the following is suitable:

15.1.1 *Drive Mechanism*— A drive mechanism for imparting to a movable loading head a uniform, controlled velocity with respect to the stationary base.

15.1.2 *Load Indicator*— A load-indicating mechanism capable of showing the total compressive force on the specimen. This force-measuring system shall be calibrated to ensure accuracy in accordance with Practices E 4.

15.2 *Bearing Blocks*— Bearing blocks shall be used to apply the load uniformly over the two contact surfaces and to prevent eccentric loading on the specimen. At least one spherical bearing block shall be used to ensure uniform bearing. Spherical bearing blocks may be used on either or both ends of the specimen, depending on the degree of parallelism of bearing surfaces (Fig. 5). The radius of the sphere shall be as small as practicable, in order to facilitate adjustment of the bearing plate to the specimen, and yet large enough to provide adequate spherical bearing area. This radius is usually one to two times the greatest cross-section dimension. The center of the sphere shall be on the plane of the



**FIG. 5** Compression of a Wood Structural Element

specimen contact surface. The size of the compression plate shall be larger than the contact surface. It has been found convenient to provide an adjustment for moving the specimen on its bearing plate with respect to the center of spherical rotation to ensure axial loading.

15.3 *Compressometer*:

15.3.1 *Gage Length*— For modulus of elasticity calculations, a device shall be provided by which the deformation of the specimen is measured with respect to specific paired gage points defining the gage length. To obtain test data representative of the test material as a whole, such paired gage points shall be located symmetrically on the lengthwise surface of the specimen as far apart as feasible, yet at least one times the larger cross-sectional dimension from each of the contact surfaces. At least two pairs of such gage points on diametrically opposite sides of the specimen shall be used to measure the average deformation.

15.3.2 *Accuracy*—The device shall be able to measure changes in deformation to three significant figures. Since gage lengths vary over a wide range, the measuring instruments should conform to their appropriate class in accordance with Practice E 83.

## 16. Test Specimen

16.1 *Material*—The test specimen shall consist of a structural member which may be solid wood, laminated wood, or a composite construction of wood or of wood combined with plastics or metals in sizes that are commercially used in structural applications, that is, in sizes greater than nominal 2 by 2-in. (38 by 38-mm) cross section (see 3.1.6).

16.2 *Identification*— Material or materials of the test specimen shall be as fully described as that for beams in 8.2.

16.3 *Specimen Dimensions*—The weight and dimensions, as well as moisture content of the specimen, shall be accurately measured before test. Weights and dimensions (length and cross section) shall be measured to three significant figures. Sufficient measurements of the cross section shall be made along the length of the specimen to describe shape characteristics and to determine the smallest section. The physical characteristics of the specimen, as described by its density and moisture content, may be determined in accordance with Test Methods D 2395 and Test Methods D 4442, respectively.

16.4 *Specimen Description*—The inherent imperfections and intentional modifications shall be described as for beams in 8.4.

16.5 *Specimen Length*— The length of the specimen shall be such that the compressive force continues to be uniformly distributed throughout the specimen during loading—hence no flexure occurs. To meet this requirement, the specimen shall be a short column having a maximum length,  $l$ , less than 17 times the least radius of gyration,  $r$ , of the cross section of the specimen (see compressive notations). The minimum length of the specimen for stress and strain measurements shall be greater than three times the larger cross section dimension or about ten times the radius of gyration.

## 17. Procedure

17.1 *Conditioning*— Unless otherwise indicated in the research program or material specification, condition the test



specimen to constant weight so it is at moisture equilibrium, under the desired environment. Approximate moisture contents with moisture meters or measure more accurately by weights of samples in accordance with Test Methods D 4442.

#### 17.2 Test Setup:

17.2.1 *Bearing Surfaces*—After the specimen length has been calculated in accordance with 17.5, cut the specimen to the proper length so that the contact surfaces are plane, parallel to each other, and normal to the long axis of the specimen. Furthermore, the axis of the specimen shall be generally parallel to the fibers of the wood.

NOTE 6—A sharp fine-toothed saw of either the crosscut or “novelty” crosscut type has been used satisfactorily for obtaining the proper end surfaces. Power equipment with accurate table guides is especially recommended for this work.

NOTE 7—It is desirable to have failures occur in the body of the specimen and not adjacent to the contact surface. Therefore, the cross-sectional areas adjacent to the loaded surface may be reinforced.

17.2.2 *Centering*—First geometrically center the specimens on the bearing plates and then adjust the spherical seats so that the specimen is loaded uniformly and axially.

17.3 *Speed of Testing*—For measuring load-deformation data, apply the load at a constant rate of head motion so that the fiber strain is  $0.001 \text{ in./in.} \cdot \text{min} \pm 25\%$  ( $0.001 \text{ mm/mm} \cdot \text{min}$ ). For measuring only compressive strength, the test may be conducted at a constant rate to achieve maximum load in about 10 min, but not less than 5 nor more than 20 min.

17.4 *Load-Deformation Curves*—If load-deformation data have been obtained, note the load and deflection at first failure, at changes in slope of curve, and at maximum load.

17.5 *Records*—Record the maximum load, as well as a description and sketch of the failure relating the latter to the location of imperfections in the specimen. Reexamine the section of the specimen containing the failure during analysis of the data.

## 18. Calculation

18.1 Compute physical and mechanical properties in accordance with Terminology E 6, and as follows (see compressive notations):

18.1.1 Stress at proportional limit =  $P'/A$  in pounds per square inch (MPa).

18.1.2 Compressive strength =  $P/A$  in pounds per square inch (MPa).

18.1.3 Modulus of elasticity =  $P'/A\epsilon$  in pounds per square inch (MPa).

## 19. Report

19.1 Report the following information:

19.1.1 Complete identification,

19.1.2 History of seasoning and conditioning,

19.1.3 Load apparatus,

19.1.4 Deflection apparatus,

19.1.5 Length and cross-section dimensions,

19.1.6 Gage length,

19.1.7 Rate of load application,

19.1.8 Computed physical and mechanical properties, including specific gravity and moisture content, compressive strength, stress at proportional limit, modulus of elasticity, and

a statistical measure of variability of these values,

19.1.9 Description of failure, and

19.1.10 Details of any deviations from the prescribed or recommended methods as outlined in the standard.

## COMPRESSION PARALLEL TO GRAIN (CRUSHING STRENGTH OF LATERALLY SUPPORTED LONG MEMBER, EFFECTIVE $l'/r < 17$ )

### 20. Scope

20.1 This test method covers the determination of the compressive properties of structural members made of solid or laminated wood, or of composite constructions when such a member has a slenderness ratio (length to least radius of gyration) of more than 17, and when such a member is to be evaluated in full size but with lateral supports which are spaced to produce an effective slenderness ratio,  $l'/r$ , of less than 17. This test method is intended primarily for members of rectangular cross section but is also applicable to irregularly shaped studs, braces, chords, round posts, or special sections.

### 21. Summary of Test Method

21.1 The structural member is subjected to a force uniformly distributed on the contact surface of the specimen in a direction generally parallel to the longitudinal axis of the wood fibers, and the force generally is uniformly distributed throughout the specimen during loading to failure without flexure along its length.

### 22. Significance and Use

22.1 The compressive properties obtained by axial compression will provide information similar to that stipulated for flexural properties in Section 6.

22.2 The compressive properties parallel to grain include modulus of elasticity, stress at proportional limit, compressive strength, and strain data beyond proportional limit.

### 23. Apparatus

23.1 *Testing Machine*—Any device having the following is suitable:

23.1.1 *Drive Mechanism*—A drive mechanism for imparting to a movable loading head a uniform, controlled velocity with respect to the stationary base.

23.1.2 *Load Indicator*—A load-indicating mechanism capable of showing the total compressive force on the specimen. This force-measuring system shall be calibrated to ensure accuracy in accordance with Practices E 4.

23.2 *Bearing Blocks*—Bearing blocks shall be used to apply the load uniformly over the two contact surfaces and to prevent eccentric loading on the specimen. One spherical bearing block shall be used to ensure uniform bearing, or a rocker-type bearing block shall be used on each end of the specimen with their axes of rotation at  $0^\circ$  to each other (Fig. 6). The radius of the sphere shall be as small as practicable, in order to facilitate adjustment of the bearing plate to the specimen, and yet large enough to provide adequate spherical bearing area. This radius is usually one to two times the greatest cross-section dimension. The center of the sphere shall be on the plane of the specimen contact surface. The size of the compression plate shall be larger than the contact surface.

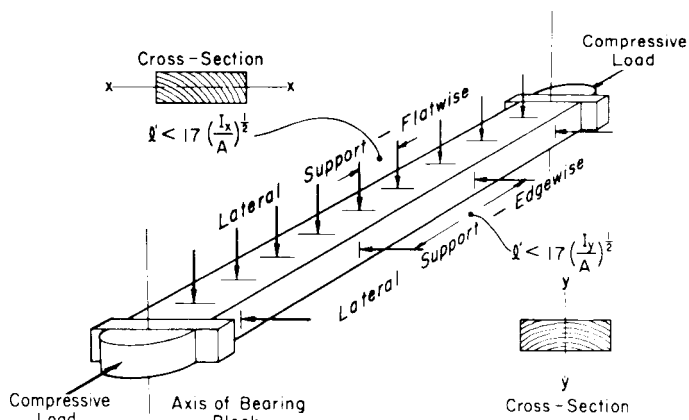

**FIG. 6 Minimum Spacing of Lateral Supports of Long Columns**

**23.3 Lateral Support:**

23.3.1 *General*—Evaluation of the crushing strength of long structural members requires that they be supported laterally to prevent buckling during the test without undue pressure against the sides of the specimen. Furthermore, the support shall not restrain either the longitudinal compressive deformation or load during test. The support shall be either continuous or intermittent. Intermittent supports shall be spaced so that the distance,  $l'$ , between supports is less than 17 times the least radius of gyration of the cross section.

23.3.2 *Rectangular Members*—The general rules for structural members apply to rectangular structural members. However, the effective column length as controlled by intermittent support spacing on flatwise face need not equal that on edgewise face. The minimum spacing of the supports on the flatwise face shall be 17 times the least radius of gyration of the cross section which is about the centroidal axis parallel to flat face. And the minimum spacing of the supports on the edgewise face shall be 17 times the other radius of gyration

(Fig. 6). A satisfactory method of providing lateral support for 2-in. (38-mm) dimension stock is shown in Fig. 7. A 27-in. (686-mm) I-beam provides the frame for the test machine. Small I-beams provide reactions for longitudinal pressure. A pivoted top I-beam provides lateral support on one flatwise face, while the web of the large I-beam provides the other. In between these steel members, metal guides on 3-in. (7.6-cm) spacing (hidden from view) attached to plywood fillers provide the flatwise support and contact surface. In between the flanges of the 27-in. I-beam, fingers and wedges provide edgewise lateral support.

**23.4 Compressometer:**

23.4.1 *Gage Length*— For modulus of elasticity calculations, a device shall be provided by which the deformation of the specimen is measured with respect to specific paired gage points defining the gage length. To obtain data representative of the test material as a whole, such paired gage points shall be located symmetrically on the lengthwise surface of the specimen as far apart as feasible, yet at least one times the larger cross-sectional dimension from each of the contact surfaces. At least two pairs of such gage points on diametrically opposite sides of the specimen shall be used to measure the average deformation.

23.4.2 *Accuracy*—The device shall be able to measure changes in deformation to three significant figures. Since gage lengths vary over a wide range, the measuring instruments should conform to their appropriate class in accordance with Practice E 83.

**24. Test Specimen**

24.1 *Material*—The test specimen shall consist of a structural member which may be solid wood, laminated wood, or it may be a composite construction of wood or of wood combined with plastics or metals in sizes that are commercially used in structural applications, that is, in sizes greater than



**FIG. 7 Compression of Long Slender Structural Member**

nominal 2 by 2-in. (38 by 38-mm) cross section (see 3.1.6).

24.2 *Identification*— Material or materials of the test specimen shall be as fully described as that for beams in 8.2.

24.3 *Specimen Dimensions*—The weight and dimensions, as well as moisture content of the specimen, shall be accurately measured before test. Weights and dimensions (length and cross section) shall be measured to three significant figures. Sufficient measurements of the cross section shall be made along the length of the specimen to describe shape characteristics and to determine the smallest section. The physical characteristics of the specimen, as described by its density and moisture content, may be determined in accordance with Test Methods D 2395 and Test Methods D 4442, respectively.

24.4 *Specimen Description*—The inherent imperfections and intentional modifications shall be described as for beams in 8.4.

24.5 *Specimen Length*— The cross-sectional and length dimensions of structural members usually have established sizes, depending on the manufacturing process and intended use, so that no modification of these dimensions is involved. Since the length has been approximately established, the full length of the member shall be tested, except for trimming or squaring the bearing surface (see 25.2.1).

## 25. Procedure

25.1 *Preliminary*— Unless otherwise indicated in the research program or material specification, condition the test specimen to constant weight so it is at moisture equilibrium, under the desired environment. Moisture contents may be approximated with moisture meters or more accurately measured by weights of samples in accordance with Test Methods D 4442.

### 25.2 Test Setup:

25.2.1 *Bearing Surfaces*— Cut the bearing surfaces of the specimen so that the contact surfaces are plane, parallel to each other, and normal to the long axis of the specimen.

25.2.2 *Setup Method*— After physical measurements have been taken and recorded, place the specimen in the testing machine between the bearing blocks at each end and between the lateral supports on the four sides. Center the contact surfaces geometrically on the bearing plates and then adjust the spherical seats for full contact. Apply a slight longitudinal pressure to hold the specimen while the lateral supports are adjusted and fastened to conform to the warp, twist, or bend of the specimen.

25.3 *Speed of Testing*— For measuring load-deformation data, apply the load at a constant rate of head motion so that the fiber strain is 0.001 in./in. · min  $\pm$  25 % (0.001 mm/mm · min). For measuring only compressive strength, the test may be conducted at a constant rate to achieve maximum load in about 10 min, but not less than 5 nor more than 20 min.

25.4 *Load-Deformation Curves*—If load-deformation data have been obtained, note load and deflection at first failure, at changes in slope of curve, and at maximum load.

25.5 *Records*—Record the maximum load as well as a description and sketch of the failure relating the latter to the location of imperfections in the specimen. Reexamine the section of the specimen containing the failure during analysis of the data.

## 26. Calculation

26.1 Compute physical and mechanical properties in accordance with Terminology E 6 and as follows (see compressive notations):

26.1.1 Stress at proportional limit =  $P'/A$  in pounds per square inch (MPa).

26.1.2 Compressive strength =  $P/A$  in pounds per square inch (MPa).

26.1.3 Modulus of elasticity =  $P'/A\epsilon$  in pounds per square inch (MPa).

## 27. Report

27.1 Report the following information:

27.1.1 Complete identification,

27.1.2 History of seasoning conditioning,

27.1.3 Load apparatus,

27.1.4 Deflection apparatus,

27.1.5 Length and cross-section dimensions,

27.1.6 Gage length,

27.1.7 Rate of load application,

27.1.8 Computed physical and mechanical properties, including specific gravity of moisture content, compressive strength, stress at proportional limit, modulus of elasticity, and a statistical measure of variability of these values,

27.1.9 Description of failure, and

27.1.10 Details of any deviations from the prescribed or recommended methods as outlined in the standard.

## TENSION PARALLEL TO GRAIN

## 28. Scope

28.1 This test method covers the determination of the tensile properties of structural elements made primarily of lumber equal to and greater than nominal 1 in. (19 mm) thick.

## 29. Summary of Test Method

29.1 The structural member is clamped at the extremities of its length and subjected to a tensile load so that in sections between clamps the tensile forces shall be axial and generally uniformly distributed throughout the cross sections without flexure along its length.

## 30. Significance and Use

30.1 The tensile properties obtained by axial tension will provide information similar to that stipulated for flexural properties in Section 6.

30.2 The tensile properties obtained include modulus of elasticity, stress at proportional limit, tensile strength, and strain data beyond proportional limit.

## 31. Apparatus

31.1 *Testing Machine*— Any device having the following is suitable:

31.1.1 *Drive Mechanism*— A drive mechanism for imparting to a movable clamp a uniform, controlled velocity with respect to a stationary clamp.

31.1.2 *Load Indicator*— A load-indicating mechanism capable of showing the total tensile force on the test section of the tension specimen. This force-measuring system shall be calibrated to ensure accuracy in accordance with Practices E 4.

31.1.3 *Grips*—Suitable grips or fastening devices shall be provided which transmit the tensile load from the movable head of the drive mechanism to one end of the test section of the tension specimen, and similar devices shall be provided to transmit the load from the stationary mechanism to the other end of the test section of the specimen. Such devices shall not apply a bending moment to the test section, allow slippage under load, inflict damage, or inflict stress concentrations to the test section. Such devices may be either plates bonded to the specimen or unbonded plates clamped to the specimen by various pressure modes.

31.1.3.1 *Grip Alignment*— The fastening device shall apply the tensile loads to the test section of the specimen without applying a bending moment. For ideal test conditions, the grips should be self-aligning, that is, they should be attached to the force mechanism of the machine in such a manner that they will move freely into axial alignment as soon as the load is applied, and thus apply uniformly distributed forces along the test section and across the test cross section (Fig. 8(a)). For less ideal test conditions, each grip should be gimbaled about one axis which should be perpendicular to the wider surface of the rectangular cross section of the test specimen, and the axis of rotation should be through the fastened area (Fig. 8(b)). When neither self-aligning grips nor single gimbaled grips are available, the specimen may be clamped in the heads of a universal-type testing machine with wedge-type jaws (Fig. 8(c)). A method of providing approximately full spherical alignment has three axes of rotation, not necessarily concurrent but, however, having a common axis longitudinal and through the centroid of the specimen (Fig. 8(d) and 9).

31.1.3.2 *Contact Surface*— The contact surface between

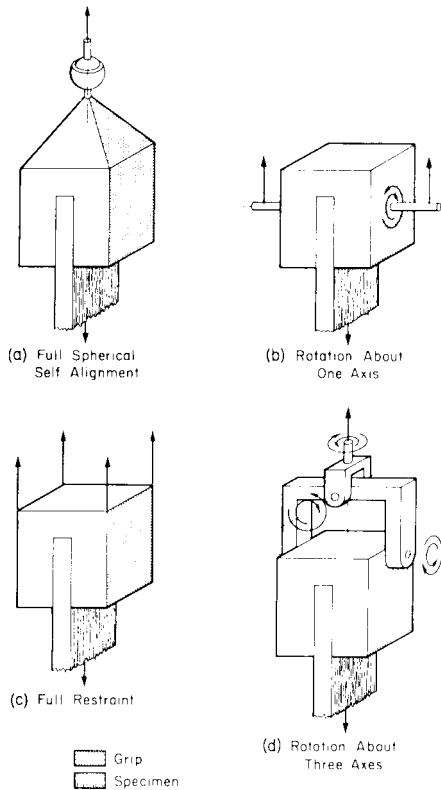

**FIG. 8 Types of Tension Grips for Structural Members**

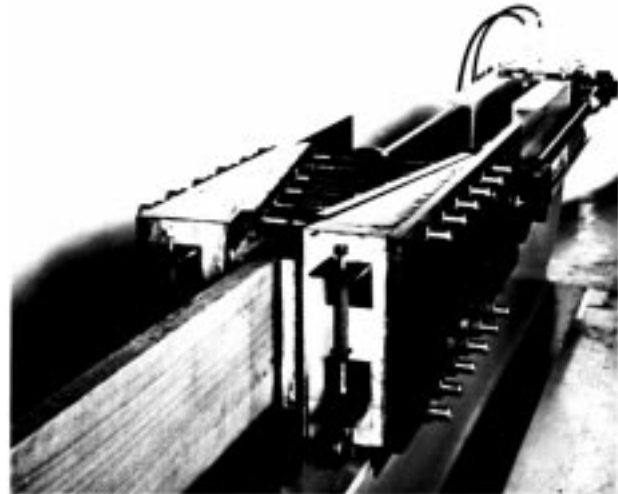

**FIG. 9 Horizontal Tensile Grips for 2 by 10-in. Structural Members**

grips and test specimen shall be such that slippage does not occur. A smooth texture on the grip surface should be avoided, as well as very rough and large projections which damage the contact surface of the wood. Grips that are surfaced with a coarse emery paper (60× aluminum oxide emery belt) have been found satisfactory for softwoods. However, for hardwoods, grips may have to be glued to the specimen to prevent slippage.

31.1.3.3 *Contact Pressure*— For unbonded grip devices, lateral pressure should be applied to the jaws of the grip so that slippage does not occur between grip and specimen. Such pressure may be applied by means of bolts or wedge-shaped jaws, or both. Wedge-shaped jaws, such as those shown on Fig. 10, which slip on the inclined plane to produce contact pressure have been found satisfactory. To eliminate stress concentration or compressive damage at the tip end of the jaw, the contact

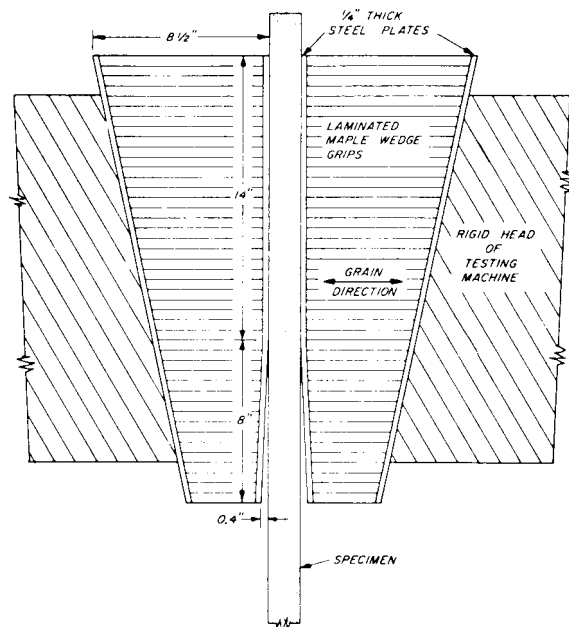

**FIG. 10 Side View of Wedge Grips Used to Anchor Full-Size Structurally, Graded Tension Specimens**



pressure should be reduced to zero. The variable thickness jaws (Fig. 10), which cause a variable contact surface and which produce a lateral pressure gradient, have been found satisfactory.

#### 31.1.4 Extensometer:

31.1.4.1 *Gage Length*—For modulus of elasticity determinations, a device shall be provided by which the elongation of the test section of the specimen is measured with respect to specific paired gage points defining the gage length. To obtain data representative of the test material as a whole, such gage points shall be symmetrically located on the lengthwise surface of the specimen as far apart as feasible, yet at least two times the larger cross-sectional dimension from each jaw edge. At least two pairs of such gage points on diametrically opposite sides of the specimen shall be used to measure the average deformation.

31.1.4.2 *Accuracy*—The device shall be able to measure changes in elongation to three significant figures. Since gage lengths vary over a wide range, the measuring instruments should conform to their appropriate class in accordance with Practice E 83.

### 32. Test Specimen

32.1 *Material*—The test specimen shall consist of a structural member which may be solid wood, laminated wood, or it may be a composite construction of wood or wood combined with plastics or metals in sizes that are commercially used in structural “tensile” applications, that is, in sizes equal to and greater than nominal 1-in. (32-mm) thick lumber.

32.2 *Identification*—Material or materials of the test specimen shall be fully described as beams in 8.2.

32.3 *Specimen Description*—The specimen shall be described in a manner similar to that outlined in 8.3 and 8.4.

32.4 *Specimen Length*—The tension specimen, which has its long axis parallel to grain in the wood, shall have a length between grips equal to at least eight times the larger cross-sectional dimension when tested in self-aligning grips (see 31.1.3.1). However, when tested without self-aligning grips, it is recommended that the length between grips be at least 20 times the greater cross-sectional dimension.

### 33. Procedure

33.1 *Conditioning*—Unless otherwise indicated, condition the specimen as outlined in 9.1.

33.2 *Test Setup*—After physical measurements have been taken and recorded, place the specimen in the grips of the load mechanism, taking care to have the long axis of the specimen and the grips coincide. The grips should securely clamp the specimen with either bolts or wedge-shaped jaws. If the latter are employed, apply a small preload to ensure that all jaws move an equal amount and maintain axial-alignment of specimen and grips. If either bolts or wedges are employed tighten the grips evenly and firmly to the degree necessary to prevent slippage. Under load, continue the tightening if necessary, even crushing the wood perpendicular to grain, so that no slipping occurs and a tensile failure occurs outside the jaw contact area.

33.3 *Speed of Testing*—For measuring load-elongation data, apply the load at a constant rate of head motion so that the fiber strain in the test section between jaws is 0.0006 in./in. ·

min  $\pm$  25 % (0.0006 mm/mm · min). For measuring only tensile strength, the load may be applied at a constant rate of grip motion so that maximum load is achieved in about 10 min but not less than 5 nor more than 20 min.

33.4 *Load-Elongation Curves*—If load-elongation data have been obtained throughout the test, correlate changes in specimen behavior, such as appearance of cracks or splinters, with elongation data.

33.5 *Records*—Record the maximum load, as well as a description and sketch of the failure relating the latter to the location of imperfections in the test section. Reexamine the section containing the failure during analysis of data.

### 34. Calculation

34.1 Compute physical and mechanical properties in accordance with Terminology E 6, and as follows (see tensile notations):

34.1.1 Stress at proportional limit =  $P'/A$  in pounds per square inch (MPa).

34.1.2 Tensile strength =  $P/A$  in pounds per square inch (MPa).

34.1.3 Modulus of elasticity =  $P'/A\epsilon$  in pounds per square inch (MPa).

### 35. Report

35.1 Report the following information:

35.1.1 Complete identification,

35.1.2 History of seasoning,

35.1.3 Load apparatus, including type of end condition,

35.1.4 Deflection apparatus,

35.1.5 Length and cross-sectional dimensions,

35.1.6 Gage length,

35.1.7 Rate of load application,

35.1.8 Computed properties,

35.1.9 Description of failures, and

35.1.10 Details of any deviations from the prescribed or recommended methods as outlined in the standard.

## TORSION

### 36. Scope

36.1 This test method covers the determination of the torsional properties of structural elements made of solid or laminated wood, or of composite constructions. This test method is intended primarily for structural element or rectangular cross section but is also applicable to beams of round or irregular shapes.

### 37. Summary of Test Method

37.1 The structural element is subjected to a torsional moment by clamping it near its ends and applying opposing couples to each clamping device. The element is deformed at a prescribed rate and coordinate observations of torque and twist are made for the duration of the test.

### 38. Significance and Use

38.1 The torsional properties obtained by twisting the structural element will provide information similar to that stipulated for flexural properties in Section 6.

38.2 The torsional properties of the element include an apparent modulus of rigidity of the element as a whole, stress at proportional limit, torsional strength, and twist beyond proportional limit.

### 39. Apparatus

39.1 *Testing Machine*—Any device having the following is suitable:

39.1.1 *Drive Mechanism*—A drive mechanism for imparting an angular displacement at a uniform rate between a movable clamp on one end of the element and another clamp at the other end.

39.1.2 *Torque Indicator*—A torque-indicating mechanism capable of showing the total couple on the element. This measuring system shall be calibrated to ensure accuracy in accordance with Practices E 4.

39.2 *Support Apparatus:*

39.2.1 *Clamps*—Each end of the element shall be securely held by metal plates of sufficient bearing area and strength to grip the element with a vise-like action without slippage, damage, or stress concentrations in the test section when the torque is applied to the assembly. The plates of the clamps shall be symmetrical about the longitudinal axis of the cross section of the element.

39.2.2 *Clamp Supports*—Each of the clamps shall be supported by roller bearings or bearing blocks that allow the structural element to rotate about its natural longitudinal axis. Such supports may be ball bearings in a rigid frame of a torque-testing machine (Figs. 11 and 12) or they may be bearing blocks (Figs. 13 and 14) on the stationary and movable frames of a universal-type test machine. Either type of support shall allow the transmission of the couple without friction to the torque measuring device, and shall allow freedom for longitudinal movement of the element during the twisting. Apparatus of Fig. 13 is not suitable for large amounts of twist unless the angles are measured at each end to enable proper torque calculation.

39.2.3 *Frame*—The frame of the torque-testing machine shall be capable of providing the reaction for the drive mechanism, the torque indicator, and the bearings. The framework necessary to provide these reactions in a universal-type test machine shall be two rigid steel beams attached to the movable and stationary heads forming an X. The extremities of the X shall bear on the lever arms attached to the test element (Fig. 13).

39.3 *Troptometer:*

39.3.1 *Gage Length*—For modulus of rigidity calculations, a device shall be provided by which the angle of twist of the

element is measured with respect to specific paired gage points defining the gage length. To obtain test data representative of the element as a whole, such paired gage points shall be located symmetrically on the lengthwise surface of the element as far apart as feasible, yet at least two times the larger cross-sectional dimension from each of the clamps. A yoke (Fig. 16) or other suitable device (Fig. 12) shall be firmly attached at each gage point to permit measurement of the angle of twist. The angle of twist is measured by observing the relative rotation of the two yokes or other devices at the gage points with the aid of any suitable apparatus including a light beam (Fig. 12), dials (Fig. 14), or string and scale (Figs. 15 and 16).

39.3.2 *Accuracy*—The device shall be able to measure changes in twist to three significant figures. Since gage lengths may vary over a wide range, the measuring instruments should conform to their appropriate class in accordance with Practice E 83.

### 40. Test Element

40.1 *Material*—The test element shall consist of a structural member, which may be solid wood, laminated wood, or a composite construction of wood or wood combined with plastics or metals in sizes that are commercially used in structural applications.

40.2 *Identification*—Material or materials of the test element shall be as fully described as for beams in 8.2.

40.3 *Element Measurements*—The weight and dimensions as well as the moisture content shall be accurately determined before test. Weights and dimensions (length and cross section) shall be measured to three significant figures. Sufficient measurements of the cross section shall be made along the length of the specimen to describe characteristics and to determine the smallest cross section. The physical characteristics of the element, as described by its density and moisture content, may be determined in accordance with Test Methods D 2395 and Test Methods D 4442, respectively.

40.4 *Element Description*—The inherent imperfections and intentional modifications shall be described as for beams in 8.4.

40.5 *Element Length*—The cross-sectional dimensions of solid wood structural elements and composite elements usually are established, depending upon the manufacturing process and intended use so that normally no modification of these dimensions is involved. However, the length of the specimen shall be at least eight times the larger cross-sectional dimension.

### 41. Procedure

41.1 *Conditioning*—Unless otherwise indicated in the research program or material specification, condition the test element to constant weight so it is at moisture equilibrium under the desired environment. Approximate moisture contents with moisture meters, or measure more accurately by weights of samples in accordance with Test Methods D 4442.

41.2 *Test Setups*—After physical measurements have been taken and recorded, place the element in the clamps of the load mechanism, taking care to have the axis of rotation of the clamps coincide with the longitudinal centroidal axis of the element. Tighten the clamps to securely hold the element in either type of testing machine. If the tests are made in a universal-type test machine, the bearing blocks shall be equal

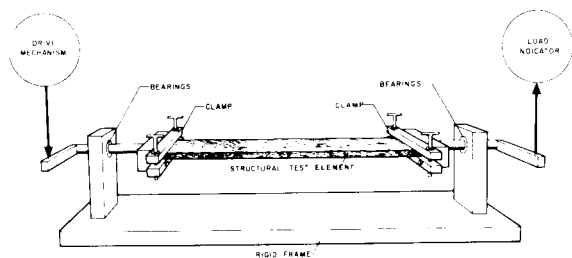

FIG. 11 Fundamentals of a Torsional Test Machine

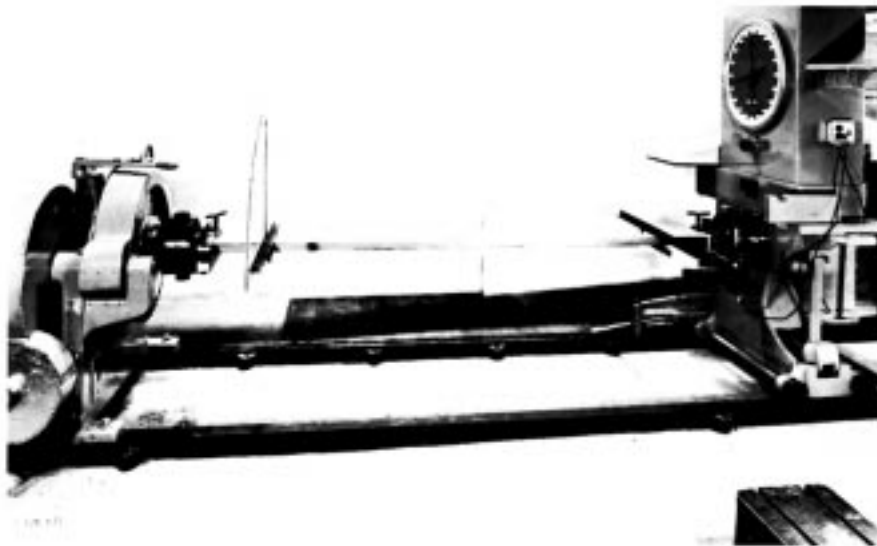

FIG. 12 Example of Torque-Testing Machine (Torsion test in apparatus meeting specification requirements)

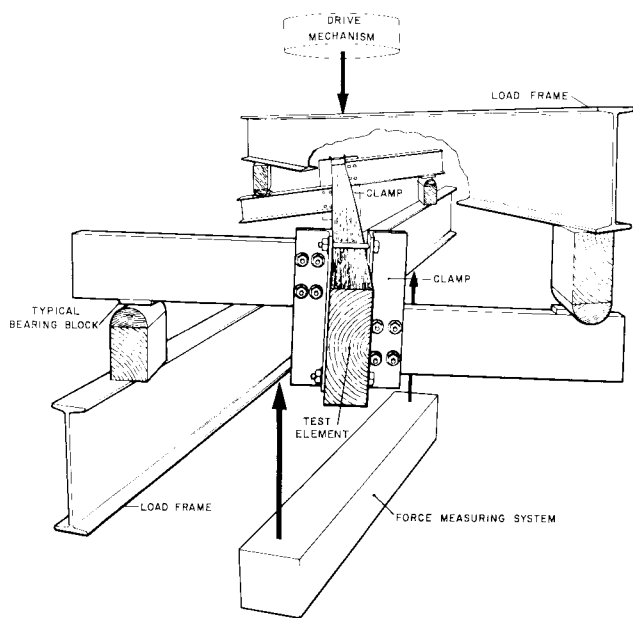

FIG. 13 Schematic Diagram of a Torsion Test Made in a Universal-Type Test Machine

distances from the axis of rotation of the element.

41.3 *Speed of Testing*— For measuring torque-twist data, apply the load at a constant rate of head motion so that the angular detrusion of the outer fibers in the test section between gage points is about 0.004 radian per inch of length (0.16 radian per metre of length) per minute  $\pm 50\%$ . For measuring only shear strength, the torque may be applied at a constant rate of twist so that maximum torque is achieved in about 10 min but not less than 5 nor more than 20 min.

41.4 *Torque-Twist Curves*—If torque-twist data have been obtained, note torque and twist at first failure, at changes in slope of curve, and at maximum torque.

41.5 *Record of Failures*—Describe failures in detail as to type, manner and order of occurrence, angle with the grain, and

position in the test element. Record descriptions relating to imperfections in the element. Reexamine the section of the element containing the failure during analysis of the data.

## 42. Calculation

42.1 Compute physical and mechanical properties in accordance with Terminology E 6 and relationships in Tables X3.1 and X3.2.

## 43. Report

43.1 Report the following information:

- 43.1.1 Complete identification,
- 43.1.2 History of seasoning and conditioning,
- 43.1.3 Apparatus for applying and measuring torque,
- 43.1.4 Apparatus for measuring angle of twist,
- 43.1.5 Length and cross-section dimensions,
- 43.1.6 Gage length,
- 43.1.7 Rate of twist applications,
- 43.1.8 Computed properties, and
- 43.1.9 Description of failures.

## SHEAR MODULUS

## 44. Scope

44.1 This test method covers the determination of the modulus of rigidity ( $G$ ) or shear modulus of structural beams made of solid or laminated wood. Application to composite constructions can only give a measure of the apparent or effective shear modulus. This test method is intended primarily for beams of rectangular cross section but is also applicable to other sections with appropriate modification of equation coefficients.

## 45. Summary of Test Method

45.1 The structural member, usually a straight or a slightly cambered beam of rectangular cross section, is subjected to a bending moment by supporting it at two locations called

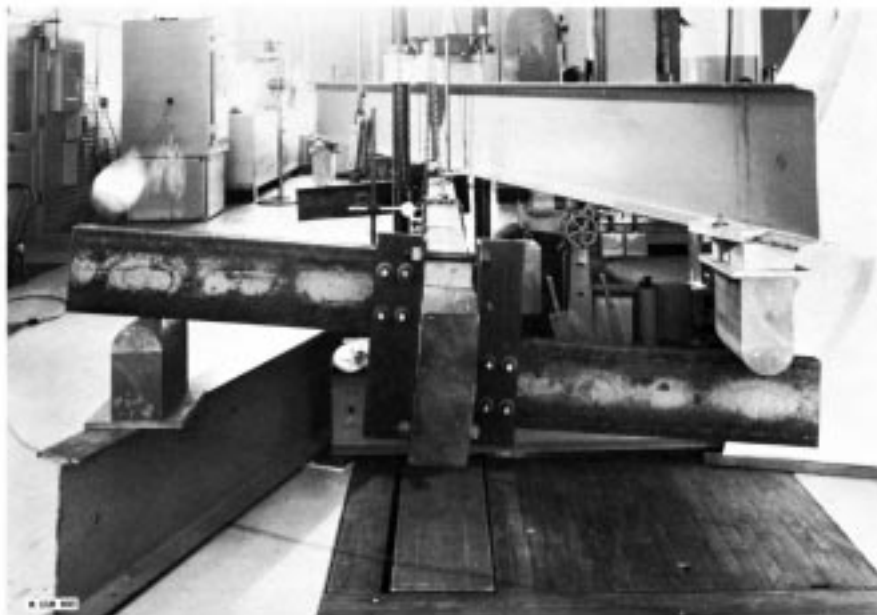

**FIG. 14 Example of Torsion Test of Structural Beam in a Universal-Type Test Machine**



**FIG. 15 Torsion Test with Yoke-Type Troptometer**

reactions, and applying a single transverse load midway between these reactions. The beam is deflected at a prescribed rate and a single observation of coordinate load and deflection is taken. This procedure is repeated on at least four different spans.

#### **46. Significance and Use**

46.1 The shear modulus established by this test method will provide information similar to that stipulated for flexural properties in Section 6.

#### **47. Apparatus**

47.1 The test machine and specimen configuration, supports, and loading are identical to Section 7 with the following exception:

47.1.1 The load shall be applied as a single, concentrated load midway between the reactions.

#### **48. Test Specimen**

48.1 See Section 8.

#### **49. Procedure**

49.1 *Conditioning*— See 9.1.

49.2 *Test Setup*—Position the specimen in the test machine as described in 9.2 and load in center point bending over at least four different spans with the same cross section at the center of each. Choose the spans so as to give approximately equal increments of  $(h/L)^2$  between them, within the range from 0.035 to 0.0025. The applied load must be sufficient to provide a reliable estimate of the initial bending stiffness of the

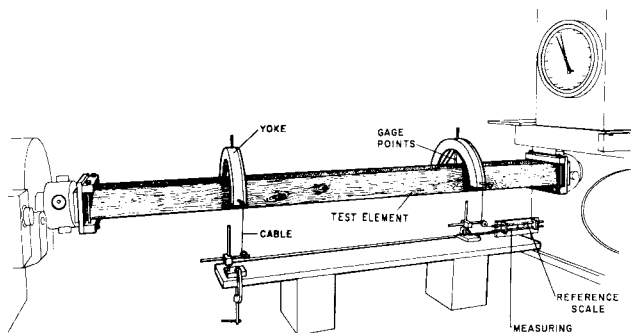

X1 140 890

**FIG. 16 Troptometer Measuring System**

specimen, but in no instance shall exceed the proportional limit or shear capacity of the specimen.

NOTE 8—Span to depth ratios of 5.5, 6.5, 8.5, and 20 meet the  $(h/L)^2$  requirements of this section.

49.3 *Load-Deflection Measurements*—Obtain load-deflection data with the apparatus described in 7.4.1. One data point is required on each span tested.

49.4 *Records*—Record span to depth ratios chosen and load levels achieved on each span.

49.5 *Speed of Testing*— See 9.3.

**50. Calculation**

50.1 Determine shear modulus by plotting  $1/E_f$  (where  $E_f$  is the apparent modulus of elasticity calculated under center point loading) versus  $(h/L)^2$  for each span tested. As indicated in Fig. 17 and in Appendix X4, shear modulus is proportional to the slope of the best-fit line between these points.

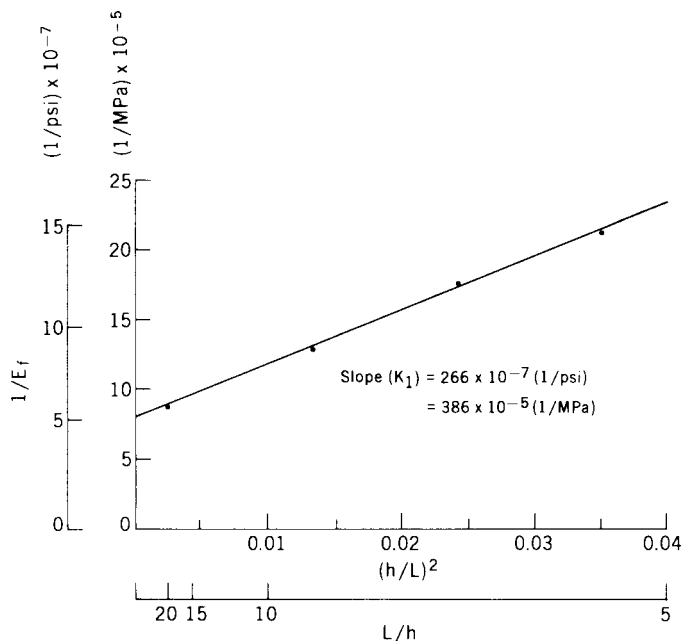

**FIG. 17 Determination of Shear Modulus**

**51. Report**

51.1 See Section 11.

**PRECISION AND BIAS**

**52. Precision and Bias**

52.1 The precision and bias of these test methods are being established.

**53. Keywords**

53.1 lumber; static test; wood



## APPENDIXES

### (Nonmandatory Information)

#### X1. PHYSICAL PROPERTIES

**TABLE X1.1 Physical Properties**

Specific gravity (at test), $G_g = CW_g/V$	Test Methods D 2395	
Specific gravity (ovendry), $G_d = G_g/(100 + MC)$		
Specific gravity (ovendry), $G_d = G_g/(100 + MC)$	Test Methods D 4442	
GENERAL NOTATIONS		
A Cross-sectional area, in. <sup>2</sup> (mm <sup>2</sup> ).	L Span of beam, in. (mm).	
C 0.061, a constant for use when $W_g$ is measured in grams in equation for specific gravity.	M Maximum bending moment at maximum load, lbf-in. (N·m).	
22.7, a constant for use when $W_g$ is measured in pounds in equation for specific gravity.		
ε Strain at proportional limit, in./in. (mm/mm).	M' Maximum bending moment at proportional limit load, lbf · in. (N · m).	
$G_d$ Specific gravity (ovendry).	P Maximum transverse load on beam, lbf (N).	
$G_g$ Specific gravity (at test).	P' Load on beam at proportional limit, lbf (N).	
I Moment of inertia of the cross section about a designated axis, in. <sup>4</sup> (mm <sup>4</sup> ).	S <sub>p</sub> Fiber stress at proportional limit, psi (MPa).	
N Rate of motion of movable head, in./min (mm/min).	S <sub>R</sub> Modulus of rupture.	
n Number of specimens in sample.	z Rate of fiber strain, in./in. (mm/mm), of outer fiber length per min.	
S Estimated standard deviation = $[(\sum X^2 - n\bar{X}^2)/(n - 1)]^{1/2}$	Δ Deflection of beam, in. (mm), at neutral axis between reaction and center of beam at the proportional limit, in. (mm).	
V Volume, in. <sup>3</sup> (mm <sup>3</sup> )	Δ <sub>L<sub>b</sub></sub> Deflection of the beam measured at midspan over distance $L_b$ , in. (mm).	
$W_g$ Weight of moisture specimen (at test), lb (g)	COMPRESSIVE NOTATIONS	
$W_d$ Weight of moisture specimen (ovendry), lb (g)	L Length of compression column, in. (mm).	
X Individual values	L' Effective length of column between supports for lateral stability, in. (mm).	
$\bar{X}$ Average of $n$ individual values.	P Maximum compressive load, lbf (N).	
FLEXURAL NOTATIONS		
a Distance from reaction to nearest load point, in. (mm) (½ shear span).	P' Compressive load at proportional limit, lbf (N).	
$A_m$ Area of graph paper under the load-deflection curve from zero load to maximum load in. <sup>2</sup> (mm <sup>2</sup> ) when deflection is measured between reaction and center of span.	r Radius of gyration = $[(I/A)]^{1/2}$ , in. (mm).	
$A_t$ Area of graph paper under load-deflection curve from zero load to failing load or arbitrary terminal load, in. <sup>2</sup> (mm <sup>2</sup> ), when deflection is measured between reaction and center of span.	TENSILE NOTATIONS	
	P Maximum tensile load, lbf (N).	
	P' Tensile load at proportional limit, lbf (N).	
	SHEAR NOTATIONS	
b Width of beam, in. (mm).	E Modulus of elasticity	
c Distance from neutral axis of beam to extreme outer fiber, in. (mm).	$E_r$ Apparent $E$ , center point loading.	
G Modulus of rigidity in shear, psi (MPa).	G Modulus of rigidity (shear modulus).	
h Depth of beam, in. (mm).	I Moment of inertia.	
k Graph paper scale constant for converting unit area of graph paper to load-deflection units.	P' Load on beam at deflection, Δ', lbf (N) (below proportional limit).	
$L_b$ Span of the beam that is used to measure deflections caused only by the bending moment, that is, no shear distortions, in. (mm).	Δ' Deflection of beam, in. (mm).	
	K Shear coefficient. Defined in Table X4.1.	
	$K_T$ Slope of line through multiple test data plotted on $(h/L)^2$ versus $(1/E)$ .	



## X2. FLEXURE

**TABLE X2.1 Flexure Formulas<sup>A</sup>**

Mechanical Properties	Cross Section		
	General	Two-Point Loading Rectangular Beam	Third-Point Loading Rectangular Beam
Fiber stress at proportional limit, $S_y$	$\frac{M'c}{I}$	$\frac{3P'a}{bh^2}$	$\frac{P'L}{bh^2}$
Modulus of rupture, $S_R$	$\frac{Mc}{I}$	$\frac{3Pa}{bh^2}$	$\frac{PL}{bh^2}$
Modulus of elasticity, $E$ (apparent $E$ )	$\frac{P'a}{48\Delta}(3L^2 - 4a^2)$	$\frac{P'a}{4bh^3\Delta}(3L^2 - 4a^2)$	$\frac{P'L^3}{4.7bh^3\Delta}$
Modulus of elasticity, $E_G$ (shear corrected $E$ )			
Deflection measured relative to reactions		$\frac{P'a(3L^2 - 4a^2)}{4bh^3\Delta\left(1 - \frac{3P'a}{5bhG\Delta}\right)}$	$\frac{P'L^3}{4.7bh^3\Delta\left(1 - \frac{P'L}{5bhG\Delta}\right)}$
Deflection measured between load points	$\frac{M'L_b^2}{8I\Delta_b}$	$\frac{3P'aL_b^2}{4bh^3\Delta_b}$	$\frac{P'LL_b^2}{4bh^3\Delta_b}$
Work to proportional limit per unit of volume, $W_k$		$\frac{P'\Delta}{2Lbh} \left[ \frac{4a(3L - 4a) + \frac{24h^2E_G}{10G}}{3L^2 - 4a^2 + \frac{24h^2E_G}{10G}} \right]$	$\frac{P'\Delta}{2Lbh} \left[ \frac{\frac{20}{9}L^2 + \frac{24h^2E_G}{10G}}{\frac{23}{9}L^2 + \frac{24h^2E_G}{10G}} \right]$
Approximate work to maximum load per unit of volume, $W_m$		$\frac{KA_m}{Lbh} \left[ \frac{4a(3L - 4a) + \frac{24h^2E_G}{10G}}{3L^2 - 4a^2 + \frac{24h^2E_G}{10G}} \right]$	$\frac{KA_m}{Lbh} \left[ \frac{\frac{20}{9}L^2 + \frac{24h^2E_G}{10G}}{\frac{23}{9}L^2 + \frac{24h^2E_G}{10G}} \right]$
Approximate total work per unit of volume, $W_t$		$\frac{KA_t}{Lbh} \left[ \frac{4a(3L - 4a) + \frac{24h^2E_G}{10G}}{3L^2 - 4a^2 + \frac{24h^2E_G}{10G}} \right]$	$\frac{KA_t}{Lbh} \left[ \frac{\frac{20}{9}L^2 + \frac{24h^2E_G}{10G}}{\frac{23}{9}L^2 + \frac{24h^2E_G}{10G}} \right]$
Shear stress, $\tau_m$		$\frac{3P}{4bh}$	$\frac{3P}{4bh}$

<sup>A</sup> For wooden beams having uniform cross section throughout their length.

## X3. TORSION

X3.1 See Table X3.1 and Table X3.2.

**TABLE X3.1 Torsion Formulas<sup>A</sup>**

Mechanical Properties	Cross Section			
	Circle	Square	Rectangle	General <sup>B</sup>
Fiber shear stress of greatest intensity at middle of long side; at proportional limit, $S_s'$	$2T/\pi r^3$ (1A)	$4.808 T/w^3$ (1B)	$8\gamma T/\mu w^2$ (1C)	$T/Q$ (1D)
Fiber shear strength of greatest intensity at middle of long side, $S_s$	$2T/\pi r^3$ (2A)	$4.808 T/w^3$ (2B)	$8\gamma T/\mu w^2$ (2C)	$T/Q$ (2D)
Fiber shear strength at middle of short side, $S_s''$			$8\gamma_1 T/\mu^3$ (3C)	
Apparent modulus of rigidity, $G$	$2L_g T/\pi r^4 \theta$ (4A)	$7.11 L_g T/w^4 \theta$ (4B)	$16L_g T/w^2[(16/3) - \lambda(t/w)] \theta$ (4C)	$L_g T/\theta K$ (4D)

<sup>A</sup> From NACA rep. 334.

<sup>B</sup> Values of "Q" and "K" may be found in Roark, R. J., *Formulas for Stress and Strain*, McGraw-Hill, 1965, p. 194.



**TABLE X3.2 Factors for Calculating Torsional Rigidity and Stress of Rectangular Prisms<sup>A</sup>**

Ratio of Sides Column 1	$\lambda$ Column 2	$\mu$ Column 3	$\gamma$ Column 4	$\gamma_1$ Column 5
1.00	3.08410	2.24923	1.35063	1.35063
1.05	3.12256	2.35908	1.39651	
1.10	3.15653	2.46374	1.43956	
1.15	3.18554	2.56330	1.47990	
1.20	3.21040	2.65788	1.51753	
1.25	3.23196	2.74772	1.55268	1.13782
1.30	3.25035	2.83306	1.58544	
1.35	3.26632	2.91379	1.61594	
1.40	3.28002	2.99046	1.64430	
1.45	3.29171	3.06319	1.67265	
1.50	3.30174	3.13217	1.69512	0.97075
1.60	3.31770	3.25977	1.73889	0.91489
1.70	3.32941	3.37486	1.77649	
1.75	3.33402	3.42843	1.79325	0.84098
1.80	3.33798	3.47890	1.80877	
1.90	3.34426	3.57320	1.83643	
2.00	3.34885	3.65891	1.86012	0.73945
2.25	3.35564	3.84194	1.90543	
2.50	3.35873	3.98984	1.93614	0.59347
2.75	3.36023	4.11143	1.95687	
3.00	3.36079	4.21307	1.97087	
3.33	...	...	...	0.44545
3.50	3.36121	4.37299	1.98672	
4.00	3.36132	4.49300	1.99395	0.37121
4.50	3.36133	4.58639	1.99724	
5.00	3.36133	4.66162	1.99874	0.29700
6.00	3.36133	4.77311	1.99974	
6.67	3.36133	...	...	0.22275
7.00	3.36133	4.85314	1.99995	
8.00	3.36133	4.91317	1.99999	0.18564
9.00	3.36133	4.95985	2.00000	
10.00	3.36133	4.99720	2.00000	0.14858
20.00	3.36133	5.16527	2.00000	0.07341
50.00	3.36133	5.26611	2.00000	
100.00	3.36133	5.29972	2.00000	
$\infty$	3.36133	5.33333	2.00000	0.00000

<sup>A</sup> Table I, "Factors for Calculating Torsional Rigidity and Stress of Rectangular Prisms," from National Advisory Committee for Aeronautics Report No. 334, "The Torsion of Members Having Sections Common in Aircraft Construction," by G. W. Trayer and H. W. March about 1929.

*Torsion Notations*

$G$	Apparent modulus of rigidity, psi (MPa).	$S_s''$	Fiber shear strength at middle of short side at maximum torque, psi (MPa).
$K$	Stiffness—shape factor.	$T$	Twisting moment or torque, lbf · in. (N · m).
$L_g$	Gage length of torsional element, in. (mm.)	$T'$	Torque at proportional limit, bf · in. (N · m).
$Q$	Stress-shape factor.	$t$	Thickness, in. (mm.)
$r$	Radius, in. (mm.)	$w$	Width of element, in. (mm).
$S_s$	Fiber shear stress of greatest intensity at middle of long side at proportional limit, psi (MPa).	$\gamma$	St. Venant constant, Column 4, Table X4.1
$S_s$	Fiber shear strength of greatest intensity at middle of long side at maximum torque, psi (MPa).	$\gamma_1$	St. Venant constant, Column 5, Table X4.1
		$\theta$	Total angle of twist, radians (in./in. or mm/mm).
		$\lambda$	St. Venant constant, Column 2, Table X4.1.
		$\mu$	St. Venant constant, Column 3, Table X4.1



## X4. SHEAR MODULUS

X4.1 The elastic deflection of a prismatic beam under a single center point load is:

$$\Delta = \frac{PL^3}{48EI} + \frac{PL}{4GA'} \quad (\text{X4.1})$$

where:

- $\Delta$  = deflection at midspan,
- $P$  = applied load,
- $L$  = span,
- $E$  = modulus of elasticity,
- $I$  = moment of inertia,
- $G$  = modulus of rigidity (shear modulus), and
- $A'$  = modified shear area.

X4.2 All parameters are self-explanatory with the exception of the modified shear area. The modified shear area is the product of the cross-sectional area,  $A$ , and a shear coefficient,  $K$ .<sup>4</sup> The shear coefficient relates the effective transverse shear strain to the average shear stress on the section. “ $K$ ” is defined as the ratio of average shear strain on a section to shear strain at the centroid. Shear coefficients have been calculated and tabulated for a variety of beam configurations.

X4.2.1 Introducing  $K$  into Eq 1:

$$\Delta = \frac{PL^3}{48EI} + \frac{PL}{4GKA} \quad (\text{X4.2})$$

X4.3 Often the relationship between deflection and elastic constants is simplified by ignoring the shear contribution, or the second term in Eq. 2. The remaining elastic constant is called the “apparent” modulus of elasticity,  $E_f$ :

$$\Delta = \frac{PL^3}{48E_f I} \quad (\text{X4.3})$$

X4.4 At the same deflection the apparent modulus of elasticity can be expressed in terms of the true elastic constants:

$$\frac{PL^3}{48E_f I} = \frac{PL^3}{48EI} + \frac{PL}{4GKA} \quad (\text{X4.4})$$

X4.5 For a rectangular section of width,  $b$ , and depth,  $h$ , Eq 4 reduces to:

$$\frac{L^2}{E_f h^2} = \frac{L^2}{Eh^2} + \frac{1}{KG} \quad (\text{X4.5})$$

**TABLE X4.1 Shear Modulus Formulas**

Mechanical Property	Formula
Modulus of elasticity, $E_f$ (apparent $E$ , center point loading)	$\frac{PL^3}{48\Delta'}$
Shear modulus, $G^A$	
Rectangular section	1.2 / $K_1^B$
Circular section	1.55 / $K_1$

<sup>A</sup> Based on solution of the equation  $\Delta = (PL^3/48EI) + (PL/4KGA)$ .  $K$  is tabulated for other cross sections by Cowper, G. R., “The Shear Coefficient in Timoshenko’s Beam Theory,” *Journal of Applied Mechanics*, ASME, 1966, pp. 335–340.

<sup>B</sup>  $K_1$  = Slope of the line plotted through the test values as shown in Fig. 17.

X4.6 Multiplying both sides of Eq 5 by  $(h/L)^2$  yields:

$$\frac{1}{E_f} = \frac{1}{E} + \frac{1}{KG} (h/L)^2 \quad (\text{X4.6})$$

X4.6.1 Equation 6 can be graphed by substituting  $y = 1/E_f$  and  $x = (h/L)^2$ . In the resulting  $y = mx + b$  graph, the slope of a line connecting multiple data points is equal to  $1/KG$ .

X4.7 For a circular section of diameter,  $h$ , Eq 4 reduces to:

$$\frac{1}{E_f} = \frac{1}{E} + \frac{3}{4KG} (h/L)^2 \quad (\text{X4.7})$$

X4.8 Using values for  $K = (10(1 + \nu))/(12 + 11\nu)$  (rectangular) and  $K = (6(1 + \nu))/(7 + 6\nu)$  (circular) and Poisson’s ratios ranging from 0.05 to 0.5 yield:<sup>4</sup>

*Rectangular:*  $K = 0.84$  to  $0.86$ , and

*Circular:*  $K = 0.86$  to  $0.90$ . (X4.8)

X4.9 On plots of  $1/E_f$  versus  $(h/L)^2$ , shear modulus,  $G$ , can be expressed in terms of the slope of the line connecting multiple observations. If the slope is called  $K_f$ ,<sup>5</sup> then:

$G = 1.17/K_f$  to  $1.20/K_f$  (rectangular), and

$G = 1.48/K_f$  to  $1.55/K_f$  (circular). (X4.9)

X4.10 As CIB/RILEM has already proposed  $1.2/K_f$  for rectangular beams, the corresponding value for circular beams,  $1.55/K_f$ , should be used.

X4.11 Determination of shear modulus for other beam cross sections must start at Eq 4, substituting appropriate values for  $I$ ,  $A$ , and  $K$ .

<sup>4</sup> Cowper, G. R., “The Shear Coefficient in Timoshenko’s Beam Theory,” *Journal of Applied Mechanics*, ASME, 1966, pp. 335–340.

<sup>5</sup> Gromala, D. S., “Determination of Modulus of Rigidity by ASTM D 198 Flexural Methods,” *Journal of Testing and Evaluation*, Vol 13, No. 5, Sept. 1985, pp. 352–355.

**NOTICE: This standard has either been superseded and replaced by a new version or discontinued.  
Contact ASTM International ([www.astm.org](http://www.astm.org)) for the latest information.**



*ASTM International takes no position respecting the validity of any patent rights asserted in connection with any item mentioned in this standard. Users of this standard are expressly advised that determination of the validity of any such patent rights, and the risk of infringement of such rights, are entirely their own responsibility.*

*This standard is subject to revision at any time by the responsible technical committee and must be reviewed every five years and if not revised, either reapproved or withdrawn. Your comments are invited either for revision of this standard or for additional standards and should be addressed to ASTM International Headquarters. Your comments will receive careful consideration at a meeting of the responsible technical committee, which you may attend. If you feel that your comments have not received a fair hearing you should make your views known to the ASTM Committee on Standards, at the address shown below.*

*This standard is copyrighted by ASTM International, 100 Barr Harbor Drive, PO Box C700, West Conshohocken, PA 19428-2959, United States. Individual reprints (single or multiple copies) of this standard may be obtained by contacting ASTM at the above address or at 610-832-9585 (phone), 610-832-9555 (fax), or [service@astm.org](mailto:service@astm.org) (e-mail); or through the ASTM website ([www.astm.org](http://www.astm.org)).*